



**DBS3900**

**V100R005C00**

# **RRU3252/RRU3256 Hardware Maintenance Guide**

**Issue**      **Draft A**  
**Date**        **2012-11-30**

**Copyright © Huawei Technologies Co., Ltd. 2012. All rights reserved.**

No part of this document may be reproduced or transmitted in any form or by any means without prior written consent of Huawei Technologies Co., Ltd.

## **Trademarks and Permissions**



HUAWEI and other Huawei trademarks are trademarks of Huawei Technologies Co., Ltd.

All other trademarks and trade names mentioned in this document are the property of their respective holders.

## **Notice**

The purchased products, services and features are stipulated by the contract made between Huawei and the customer. All or part of the products, services and features described in this document may not be within the purchase scope or the usage scope. Unless otherwise specified in the contract, all statements, information, and recommendations in this document are provided "AS IS" without warranties, guarantees or representations of any kind, either express or implied.

The information in this document is subject to change without notice. Every effort has been made in the preparation of this document to ensure accuracy of the contents, but all statements, information, and recommendations in this document do not constitute a warranty of any kind, express or implied.

## **Huawei Technologies Co., Ltd.**

Address: Huawei Industrial Base  
Bantian, Longgang  
Shenzhen 518129  
People's Republic of China

Website: <http://www.huawei.com>

Email: [support@huawei.com](mailto:support@huawei.com)

---

# About This Document

---

## Purpose

This document describes routine maintenance procedures for an RRU3252/RRU3256 (referred to as RRU in this document), such as equipment preventive maintenance and power-on and power-off operations. It also describes how to replace the RRU and optical modules.

## Product Version

The following table lists the product version related to this document.

Product Name	Product Version
DBS3900 LTE TDD	V100R005C00 and later versions

## Intended Audience

This document is intended for:

- System engineers
- Site maintenance engineers

## Organization

### 1 Change History

This chapter describes changes in the *RRU3252/RRU3256 Hardware Maintenance Guide*.

### 2 Preventive Maintenance Items for an RRU

Preventive maintenance for an RRU improves RRU reliability. You are advised to perform scheduled maintenance yearly.

### 3 Powering On and Powering Off an RRU

After an RRU is powered on, the RRU indicator status and voltage must be checked. Before an RRU is powered off, you must decide whether to power off the RRU in a normal situation or an emergency based on onsite requirements.

#### 4 Replacing an RRU

A distributed base station consists of RRUs and a BBU. Replacing an RRU interrupts all the services carried by the RRU, and alarms are generated.





#### 5 Replacing an Optical Module

An optical module provides optical-electrical conversion ports, enabling optical transmission between an RRU and other devices. Optical cables inserted into an optical module must be removed before the optical module is replaced. Replacing an optical module interrupts CPRI signal transmission.

## Conventions

### Symbol Conventions

The symbols that may be found in this document are defined as follows.

Symbol	Description
 <b>DANGER</b>	Indicates a hazard with a high level of risk, which if not avoided, will result in death or serious injury.
 <b>WARNING</b>	Indicates a hazard with a medium or low level of risk, which if not avoided, could result in minor or moderate injury.
 <b>CAUTION</b>	Indicates a potentially hazardous situation, which if not avoided, could result in equipment damage, data loss, performance degradation, or unexpected results.
 <b>TIP</b>	Indicates a tip that may help you solve a problem or save time.
 <b>NOTE</b>	Provides additional information to emphasize or supplement important points of the main text.

### General Conventions

The general conventions that may be found in this document are defined as follows.

Convention	Description
Times New Roman	Normal paragraphs are in Times New Roman.
<b>Boldface</b>	Names of files, directories, folders, and users are in <b>boldface</b> . For example, log in as user <b>root</b> .
<i>Italic</i>	Book titles are in <i>italics</i> .

Convention	Description
Courier New	Examples of information displayed on the screen are in Courier New.

### Command Conventions

The command conventions that may be found in this document are defined as follows.

Convention	Description
<b>Boldface</b>	The keywords of a command line are in <b>boldface</b> .
<i>Italic</i>	Command arguments are in <i>italics</i> .
[ ]	Items (keywords or arguments) in brackets [ ] are optional.
{ x   y   ... }	Optional items are grouped in braces and separated by vertical bars. One item is selected.
[ x   y   ... ]	Optional items are grouped in brackets and separated by vertical bars. One item is selected or no item is selected.
{ x   y   ... }*	Optional items are grouped in braces and separated by vertical bars. A minimum of one item or a maximum of all items can be selected.
[ x   y   ... ]*	Optional items are grouped in brackets and separated by vertical bars. Several items or no item can be selected.

### GUI Conventions

The GUI conventions that may be found in this document are defined as follows.

Convention	Description
<b>Boldface</b>	Buttons, menus, parameters, tabs, window, and dialog titles are in <b>boldface</b> . For example, click <b>OK</b> .
>	Multi-level menus are in <b>boldface</b> and separated by the ">" signs. For example, choose <b>File &gt; Create &gt; Folder</b> .

### Keyboard Operations

The keyboard operations that may be found in this document are defined as follows.

Format	Description
<b>Key</b>	Press the key. For example, press <b>Enter</b> and press <b>Tab</b> .

<b>Format</b>	<b>Description</b>
<b>Key 1+Key 2</b>	Press the keys concurrently. For example, pressing <b>Ctrl+Alt+A</b> means the three keys should be pressed concurrently.
<b>Key 1, Key 2</b>	Press the keys in turn. For example, pressing <b>Alt, A</b> means the two keys should be pressed in turn.

### Mouse Operations

The mouse operations that may be found in this document are defined as follows.

<b>Action</b>	<b>Description</b>
Click	Select and release the primary mouse button without moving the pointer.
Double-click	Press the primary mouse button twice continuously and quickly without moving the pointer.
Drag	Press and hold the primary mouse button and move the pointer to a certain position.

---

# Contents

---

<b>About This Document.....</b>	<b>ii</b>
<b>1 Change History.....</b>	<b>1</b>
<b>2 Preventive Maintenance Items for an RRU.....</b>	<b>2</b>
<b>3 Powering On and Powering Off an RRU.....</b>	<b>4</b>
3.1 Powering On an RRU.....	5
3.2 Powering Off an RRU.....	6
<b>4 Replacing an RRU.....</b>	<b>7</b>
<b>5 Replacing an Optical Module.....</b>	<b>10</b>

# 1 Change History

---

This chapter describes changes in the *RRU3252/RRU3256 Hardware Maintenance Guide*.

## **Draft A (2012-11-30)**

This is a draft.



# 2 Preventive Maintenance Items for an RRU

Preventive maintenance for an RRU improves RRU reliability. You are advised to perform scheduled maintenance yearly.



## DANGER

While working at a high place, be careful not to drop any objects. Falling objects may cause serious injury or death. All maintenance personnel must wear a helmet and avoid standing in areas with a danger.

The items listed in the following table are not mandatory but strongly recommended. [Table 2-1](#) lists the preventive maintenance items for an RRU.

**Table 2-1** Preventive maintenance items for an RRU

SN	Checklist
1	All RRUs are properly installed and in good conditions.
2	Cables at the cable inlet of a cabinet are sealed properly.
3	All RF cables are intact and free from any cracks, cuts, or other damage.
4	All RF cable connectors are sealed properly.
5	All RF cable conduits are in good conditions.
6	All power cables are intact and free from any cracks, cuts, or other damage.
7	All power cable connectors are in good conditions.
8	All power cable conduits are in good conditions.
9	All shield layers of power cables are in good conditions.
10	All power cables are sealed properly.
11	All CPRI fiber optic cables are intact and free from any cracks, cuts, or other damage.
12	All screws are tightened on the cover plate of the maintenance cavity.

SN	Checklist
13	All optional RET cables are intact and free from any cracks, cuts, or other damage.
14	Connectors of all optional RET cables are sealed properly.
15	All optional alarm cables are securely installed and free from any damage.

If any of the statements in the checklist cannot be complied with, perform the following corrective actions:

1. Tighten all connections.
2. Report any other faults found when filling in the checklist to the supervisor, because only qualified or trained field engineers are permitted to climb towers for further repairs.

# 3 Powering On and Powering Off an RRU

---

## About This Chapter

After an RRU is powered on, the RRU indicator status and voltage must be checked. Before an RRU is powered off, you must decide whether to power off the RRU in a normal situation or an emergency based on onsite requirements.

### [3.1 Powering On an RRU](#)

Set the corresponding circuit breaker on the auxiliary power device for the RRU to ON, and check the operating status of the RRU by observing the status of RRU indicators.

### [3.2 Powering Off an RRU](#)

You can power off an RRU either in a normal situation or an emergency. A normal situation refers to the cases such as equipment reparenting or anticipated interruption of regional mains supply. An emergency refers to the cases such as a fire, smoke, and water damage at the site.

## 3.1 Powering On an RRU

Set the corresponding circuit breaker on the auxiliary power device for the RRU to ON, and check the operating status of the RRU by observing the status of RRU indicators.

### Prerequisites

- The RRU hardware is installed and RRU cable connections are secure.
- The input voltage of the RRU ranges from -32 V DC to -60 V DC.

### Context



#### CAUTION

After you unpack an RRU, you must power on it within 24 hours. If you power off the RRU for maintenance, you must restore power to the RRU within 24 hours.

---

### Procedure

- Step 1** Set the corresponding circuit breaker on the auxiliary power device for the RRU to ON to power on the RRU.



#### DANGER

Do not look into the optical module without eye protection after the RRU is powered on.

---

- Step 2** Keep the RRU running for three to five minutes to check the status of RRU indicators. For details, see RRU Indicators.

 **NOTE**

If RRUs are cascaded, check the status of all RRU indicators.

- Step 3** Take corresponding actions based on the status of the indicators.

If...	Then...
The RRU is working properly	End the power-on check task.
The RRU is faulty	Set the circuit breaker to OFF. Rectify the fault, and then go to <a href="#">Step 1</a> .

----End

## 3.2 Powering Off an RRU

You can power off an RRU either in a normal situation or an emergency. A normal situation refers to the cases such as equipment reparenting or anticipated interruption of regional mains supply. An emergency refers to the cases such as a fire, smoke, and water damage at the site.

### Procedure

- Power-off in a normal situation  
Set the corresponding circuit breaker on the auxiliary power device for the RRU to OFF.
- Power-off in an emergency



### CAUTION

Power-off in an emergency may damage the RRU, and do not use it in normal situations.

---

1. Power off the auxiliary power device for the RRU.
2. If time permits, set the corresponding circuit breaker on the auxiliary power device for the RRU to OFF.

----End

# 4 Replacing an RRU

---

A distributed base station consists of RRUs and a BBU. Replacing an RRU interrupts all the services carried by the RRU, and alarms are generated.

## Prerequisites

- The test UE communicates with the base station properly.
- The types of faulty RRUs are confirmed as follows:
  - If RRUs can be queried online, run the **DSP BRDMFRINFO** command on the LMT to query the electronic labels of the RRUs.
  - If RRUs cannot be queried online, the information about the RRUs can be queried offline on the M2000. For details, see the procedure for querying inventory data in the M2000 documentation.
- Tools and materials, such as ESD gloves, M4 Phillips screwdrivers, M6 Phillips screwdrivers, waterproof tape, and PVC insulation tape, are ready.
- The number of RRUs to be replaced are confirmed, and new RRUs are ready.

## Procedure

- Step 1** Run the **BLK BRD** command to block the RRU.
- Step 2** Power off the RRU by referring to [3.2 Powering Off an RRU](#).
- Step 3** Wear ESD gloves.



### CAUTION

- Take proper ESD protection measures, for example, wear ESD gloves, to prevent electrostatic damage to modules or electronic components.
  - Pay attention to the high temperature while replacing an RRU without housing.
- 

- Step 4** Use an M4 Phillips screwdriver to loosen the protection screw on the cover plate of the RRU cabling cavity, and pull the handle outwards to open the cover plate.
- Step 5** Record the cable connections in the cabling cavity.

**Step 6** Disconnect cables from the cabling cavity and the bottom of the RRU.

**Step 7** Use an M4 Phillips screwdriver to loosen the captive screws on the two hoist clamps on the main mounting bracket, as shown in [Figure 4-1](#).

 **NOTE**

In scenarios where RRUs are installed in centralized mode, the RRU in the middle can be removed without removing the two RRUs on its right and left sides, in the same procedure as that for removing a single RRU.

**Figure 4-1** Loosening the screws on the main mounting bracket

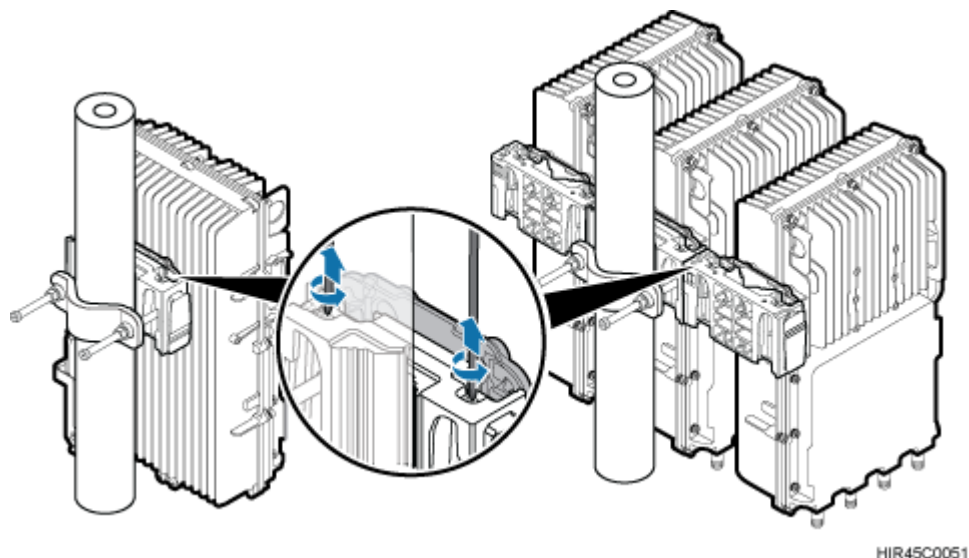

**Step 8** Hold the RRU and move it upwards to remove it, as shown in [Figure 4-2](#).

**Figure 4-2** Removing an RRU

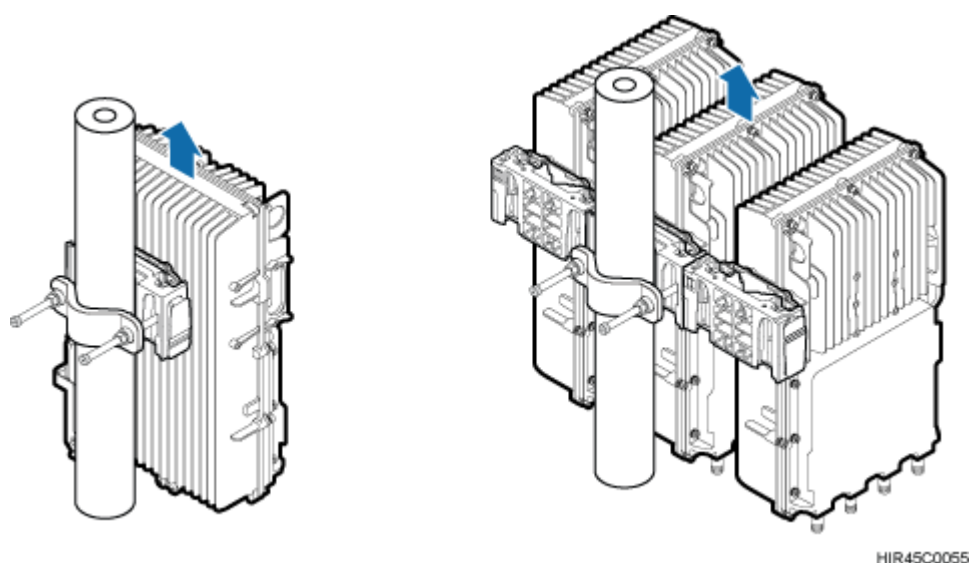



## CAUTION

When removing the RRU, hold the RRU handle with one hand, support the RRU bottom with the other hand, and move the RRU upwards.

---

- Step 9** Tighten the captive screws on the two hoist clamps on the main mounting bracket with a torque of 1.4 N·m (12.39 lbf·in.).
- Step 10** Install a new RRU.
- Step 11** Install all required cables to the RRU and ensure that a waterproof block is inserted into each vacant cable trough in the cabling cavity.
- Step 12** Close the cover plate of the RRU cabling cavity, and then tighten the protection screw on the cover plate with a torque of 0.8 N·m (7.08 lbf·in.).
- Step 13** Power on the RRU by referring to [3.1 Powering On an RRU](#).
- Step 14** Check the operating status of the new RRU by observing the status of RRU indicators. For details about the status of the indicators, see RRU Indicators.
- Step 15** Run the **UBL BRD** command to unblock the RRU.
- Step 16** Take off the ESD gloves, and pack up all the tools.

---End

## Follow-up Procedure

- Place the removed RRU into the ESD box or bag. Then, place the ESD box or bag into a foam-padded carton or the packing box of the new RRU.
- Fill in the fault form with detailed information about the removed component.
- Contact the local Huawei office to handle the faulty component.



# 5 Replacing an Optical Module

---

An optical module provides optical-electrical conversion ports, enabling optical transmission between an RRU and other devices. Optical cables inserted into an optical module must be removed before the optical module is replaced. Replacing an optical module interrupts CPRI signal transmission.

## Prerequisites

- New optical modules are sufficient and the type of them is the same as that of the faulty ones based on the labels on optical modules.
- The following tools and materials are available: M4 Phillips screwdriver, ESD gloves, and ESD box or bag.

## Context

- Optical modules are hot-swappable when the same CPRI port is used.
- It takes about 5 minutes to replace an optical module on the RRU, which involves removing fiber optic cables and a faulty optical module, installing a new optical module and the fiber optic cable, and waiting for CPRI links to recover.

## Procedure

**Step 1** Wear ESD gloves.



### CAUTION

Take proper ESD protection measures, for example, wear ESD gloves, to prevent electrostatic damage to the boards, modules, or electronic components.

---

**Step 2** Use an M4 Phillips screwdriver to loosen the protection screw on the cover plate of the RRU cabling cavity and then pull the handle outwards to open the cover plate.

**Step 3** Record the connections of the optical module and fiber optic cables.

**Step 4** Press the latch on the connector of the fiber optic cable, and then remove the connector from the faulty optical module.



## WARNING

Do not look into the fiber optic cable and optical module without eye protection after the fiber optic cable is removed from the optical module.

---

**Step 5** Lower the puller on the faulty optical module, and then pull the puller until the optical module is removed from the RRU.

**Step 6** Install the new optical module on the RRU.



### NOTE

An optical module to be replaced or installed must match the data transmission rate over a CPRI port.

**Step 7** Connect the fiber optic cable to the new optical module.

**Step 8** Observe the indicators near the CPRI0/IR0 and CPRI1/IR1 ports and check whether CPRI signal transmission is normal. For details about the indicator meanings, see RRU Indicators.

**Step 9** Reinstall the cables in the cabling cavity.

**Step 10** Close the cover plate of the RRU cabling cavity and then tighten the protection screw on the cover plate with a torque of 0.8 N·m (7.08 lbf·in.).

**Step 11** Take off the ESD gloves and pack up all tools.

---End

## Follow-up Procedure

- Place the removed optical module into an ESD box or bag. Then, place the ESD box or bag into a foam-padded carton or into the packing box of the new optical module.
- Fill in the fault form with detailed information about the removed component.
- Contact the local Huawei office to handle the faulty optical module.