

DBS3900(ICR)

Installation Guide

Issue **01**

Date **2011-03-30**

Copyright © Huawei Technologies Co., Ltd. 2011. All rights reserved.

No part of this document may be reproduced or transmitted in any form or by any means without prior written consent of Huawei Technologies Co., Ltd.

Trademarks and Permissions



HUAWEI and other Huawei trademarks are trademarks of Huawei Technologies Co., Ltd.

All other trademarks and trade names mentioned in this document are the property of their respective holders.

Notice

The purchased products, services and features are stipulated by the contract made between Huawei and the customer. All or part of the products, services and features described in this document may not be within the purchase scope or the usage scope. Unless otherwise specified in the contract, all statements, information, and recommendations in this document are provided "AS IS" without warranties, guarantees or representations of any kind, either express or implied.

The information in this document is subject to change without notice. Every effort has been made in the preparation of this document to ensure accuracy of the contents, but all statements, information, and recommendations in this document do not constitute the warranty of any kind, express or implied.

Huawei Technologies Co., Ltd.

Address: Huawei Industrial Base
Bantian, Longgang
Shenzhen 518129
People's Republic of China

Website: <http://www.huawei.com>

Email: support@huawei.com

About This Document

Purpose

This document describes the procedures for installing the DBS3900 devices on the Indoor Centralized Rack (ICR).

Product Version

The following table lists the product versions related to this document.

Product Name	Product Version
DBS3900	V100R004
DBS3900 WCDMA	V200R013
DBS3900 LTE	V100R003C00
DBS3900 GSM	V100R013

Intended Audience

This document is intended for:

- Base station installation engineers

Organization

[1 Changes in the DBS3900 \(ICR\) Installation Guide](#)

[2 Installation Preparations](#)

This chapter describes the tools and instruments required for installation and the skills and prerequisites required for onsite installation engineers.

3 Information About the Installation

This chapter describes the information about the installation, including exterior, installation scenario, and space requirements

4 Unpacking the Equipment

Unpack and check the delivered equipment to ensure that all the materials are included and intact.

5 Obtaining the ESN

The Electronic Serial Number (ESN) is a unique identifier of a Network Element (NE). Record the ESN for later commissioning of the base station before installation.

6 Installation Process

This section describes the process of installing the DBS39000 on the ICR.

7 Assembling the IFS06

This chapter describes the procedure for assembling the IFS06.

8 Installing the IFS06

This chapter describes the procedure for installing the IFS06 on the concrete floor and ESD floor.

9 Installing the Main Bracket for the RRU

This chapter describes the procedure for installing the main bracket for the DC RRU and AC RRU.

10 Installing the GPS Surge Protector

This chapter describes the procedure for installing the GPS surge protector.

11 Installing the IMB03

This chapter describes the procedure for installing the IMB03.

12 Installing the Equipotential Cable and PGND Cable

This chapter describes the procedures for installing the equipotential cable and PGND cable.

13 Installing Devices in the IMB03

This chapter describes the installation of the devices in the IMB03.

14 Installing the RRU

This section describes the procedure for installing the AC RRU and DC RRU.

15 Installing Cables

This chapter describes the procedure for installing all the cables.

16 Checklist for the DBS3900 Hardware Installation

This section describes the checklist for the DBS3900 hardware installation.

17 Performing the DBS3900 Power-On Check

After all devices are installed, you need to check the power-on status of the BBU and RRU.





18 Installing the Cover Plate for the IMB03

This section describes the procedure for installing the cover plate for the IMB03.

Conventions

Symbol Conventions

The symbols that may be found in this document are defined as follows.

Symbol	Description
 DANGER	Indicates a hazard with a high level of risk, which if not avoided, will result in death or serious injury.
 WARNING	Indicates a hazard with a medium or low level of risk, which if not avoided, could result in minor or moderate injury.
 CAUTION	Indicates a potentially hazardous situation, which if not avoided, could result in equipment damage, data loss, performance degradation, or unexpected results.
 TIP	Indicates a tip that may help you solve a problem or save time.
 NOTE	Provides additional information to emphasize or supplement important points of the main text.

General Conventions

The general conventions that may be found in this document are defined as follows.

Convention	Description
Times New Roman	Normal paragraphs are in Times New Roman.
Boldface	Names of files, directories, folders, and users are in boldface . For example, log in as user root .
<i>Italic</i>	Book titles are in <i>italics</i> .
Courier New	Examples of information displayed on the screen are in Courier New.

Command Conventions

The command conventions that may be found in this document are defined as follows.

Convention	Description
Boldface	The keywords of a command line are in boldface .
<i>Italic</i>	Command arguments are in <i>italics</i> .

Convention	Description
[]	Items (keywords or arguments) in brackets [] are optional.
{ x y ... }	Optional items are grouped in braces and separated by vertical bars. One item is selected.
[x y ...]	Optional items are grouped in brackets and separated by vertical bars. One item is selected or no item is selected.
{ x y ... }*	Optional items are grouped in braces and separated by vertical bars. A minimum of one item or a maximum of all items can be selected.
[x y ...]*	Optional items are grouped in brackets and separated by vertical bars. Several items or no item can be selected.

GUI Conventions

The GUI conventions that may be found in this document are defined as follows.

Convention	Description
Boldface	Buttons, menus, parameters, tabs, window, and dialog titles are in boldface . For example, click OK .
>	Multi-level menus are in boldface and separated by the ">" signs. For example, choose File > Create > Folder .

Keyboard Operations

The keyboard operations that may be found in this document are defined as follows.

Format	Description
Key	Press the key. For example, press Enter and press Tab .
Key 1+Key 2	Press the keys concurrently. For example, pressing Ctrl+Alt+A means the three keys should be pressed concurrently.
Key 1, Key 2	Press the keys in turn. For example, pressing Alt, A means the two keys should be pressed in turn.

Mouse Operations

The mouse operations that may be found in this document are defined as follows.

Action	Description
Click	Select and release the primary mouse button without moving the pointer.
Double-click	Press the primary mouse button twice continuously and quickly without moving the pointer.
Drag	Press and hold the primary mouse button and move the pointer to a certain position.

Contents

About This Document.....	iii
1 Changes in the DBS3900 (ICR) Installation Guide.....	1-1
2 Installation Preparations.....	2-1
2.1 Making Documents Available.....	2-2
2.2 Tools and Instruments.....	2-2
2.3 Skills and Requirements for Onsite Personnel.....	2-3
3 Information About the Installation.....	3-1
3.1 Overview of Devices.....	3-2
3.2 Installation Options.....	3-5
3.2.1 Height-Restricted Scenario.....	3-5
3.2.2 Height-Unrestricted Scenario.....	3-17
3.3 Dimensions and Installation Clearance Requirements.....	3-35
4 Unpacking the Equipment.....	4-1
5 Obtaining the ESN.....	5-1
6 Installation Process.....	6-1
7 Assembling the IFS06.....	7-1
8 Installing the IFS06.....	8-1
8.1 Installing the IFS06 on the Concrete Floor.....	8-2
8.2 Installing the IFS06 on the ESD Floor.....	8-6
9 Installing the Main Bracket for the RRU.....	9-1
9.1 Installing the Main Bracket for the DC RRU.....	9-2
9.2 Installing the Main Bracket for the AC RRU.....	9-3
10 Installing the GPS Surge Protector.....	10-1
11 Installing the IMB03.....	11-1
11.1 Installing the IMB03 on the Upper Level Separately.....	11-2
11.2 Installing the IMB03 on the Lower Level Separately.....	11-3
11.3 Installing the IMB03s on the Upper and Lower Levels.....	11-5
12 Installing the Equipotential Cable and PGND Cable.....	12-1

13 Installing Devices in the IMB03.....	13-1
13.1 Installing the BBU.....	13-2
13.2 Installing the DCDU-03B.....	13-3
13.3 (Optional) Installing the Power Equipment (DC/DC).....	13-4
13.4 (Optional) Installing the Power Equipment (AC/DC).....	13-6
14 Installing the RRU.....	14-1
14.1 Installing the DC RRU.....	14-2
14.2 Installing the AC RRU.....	14-5
15 Installing Cables.....	15-1
15.1 Cabling Requirements.....	15-3
15.2 Cable Connections.....	15-4
15.2.1 Cable Connections (-48 V DC, Six RRU3008s).....	15-5
15.2.2 Cable Connections (-48 V DC, Six RRU3804s).....	15-7
15.2.3 Cable Connections (-48 V DC, Six RRU3201s).....	15-8
15.2.4 Cable Connections (-48 V DC, Six RRU3908s).....	15-10
15.2.5 Cable Connections (-48 V DC, Three RRU3908s+Three RRU3804s).....	15-12
15.2.6 Cable Connections (-48 V DC, Three RRU3008s+Three RRU3804s).....	15-16
15.2.7 Cable Connections (-48 V, Three RRU3908s + Three RRU3201s).....	15-18
15.2.8 Cable Connections (-48 V DC, Three RRU3008s+Three RRU3201s).....	15-22
15.2.9 Cable Connections (-48 V DC, Three RRU3804s+Three RRU3201s).....	15-24
15.2.10 Cable Connections (-48 V DC, Six RRU3008s+Six RRU3804s).....	15-26
15.2.11 Cable Connections (-48 V DC, Six RRU3908s+Six RRU3804s).....	15-28
15.2.12 Cable Connections (-48 V DC, Six RRU3908s+Six RRU3201s).....	15-33
15.2.13 Cable Connections (-48 V DC, Six RRU3008s+Six RRU3201s).....	15-39
15.2.14 Cable Connections (-48 V DC, Six RRU3804s+Six RRU3201s).....	15-41
15.2.15 Cable Connections (AC RRU).....	15-43
15.2.16 Cable Connections (220 V AC).....	15-44
15.2.17 Cable Connections (+24 V DC).....	15-45
15.3 Cable Installation Process.....	15-46
15.4 Cable Routes.....	15-47
15.5 Installing the PGND Cable for the RRU.....	15-48
15.6 Installing the Power Cable for the BBU.....	15-50
15.7 Installing the Input Power Cable.....	15-51
15.8 (Optional) Installing the Power Cable and Monitoring Signal Cable for the DCDU.....	15-54
15.9 Installing the Power Cable for the RRU.....	15-56
15.10 Installing the E1/T1 Cable (FE/GE Cable or FE/GE Optical Cable).....	15-59
15.11 Installing the CPRI Optical Cable.....	15-61
15.12 Installing the Antenna Jumper for the RRU.....	15-64
15.13 Installing a GPS Clock Signal Cable.....	15-67
16 Checklist for the DBS3900 Hardware Installation.....	16-1
17 Performing the DBS3900 Power-On Check.....	17-1

18 Installing the Cover Plate for the IMB03.....18-1

Figures

Figure 3-1 DCDU-03B.....	3-3
Figure 3-2 BBU3900.....	3-3
Figure 3-3 RRU.....	3-4
Figure 3-4 Power equipment (AC/DC).....	3-4
Figure 3-5 Power equipment (DC/DC).....	3-5
Figure 3-6 Height-restricted scenario.....	3-6
Figure 3-7 Height-restricted scenario (-48 V DC).....	3-7
Figure 3-8 Height-restricted scenario (-48 V DC).....	3-8
Figure 3-9 Height-restricted scenario (-48 V DC).....	3-9
Figure 3-10 Installation of the DC RRUs on the IFS06.....	3-10
Figure 3-11 Height-restricted scenario (220 V AC).....	3-11
Figure 3-12 Height-restricted scenario (220 V AC).....	3-12
Figure 3-13 Installation of the DC RRU on the IFS06.....	3-13
Figure 3-14 Installation of AC RRUs on the IFS06.....	3-14
Figure 3-15 Height-restricted scenario (+24 V DC).....	3-15
Figure 3-16 Height-restricted scenario (+24 V DC).....	3-16
Figure 3-17 Installation of the DC RRUs on the IFS06.....	3-17
Figure 3-18 Height-unrestricted scenario.....	3-18
Figure 3-19 Height-unrestricted scenario (-48 V DC).....	3-19
Figure 3-20 Height-unrestricted scenario (-48 V DC).....	3-20
Figure 3-21 Height-unrestricted triple-mode scenario (-48 V DC).....	3-21
Figure 3-22 Height-unrestricted scenario (-48 V DC).....	3-22
Figure 3-23 Height-unrestricted triple-mode scenario (-48 V DC).....	3-23
Figure 3-24 Installation of the DC RRUs on the IFS06.....	3-24
Figure 3-25 Height-unrestricted scenario (220 V AC).....	3-25
Figure 3-26 Height-unrestricted scenario (220 V AC).....	3-26
Figure 3-27 Height-unrestricted scenario (220 V AC).....	3-27
Figure 3-28 Height-unrestricted triple-mode scenario (220 V AC).....	3-28
Figure 3-29 Installation of the DC RRUs on the IFS06.....	3-29
Figure 3-30 Installation of AC RRUs on the IFS06.....	3-30
Figure 3-31 Height-unrestricted scenario (+24 V DC).....	3-31
Figure 3-32 Height-unrestricted scenario (+24 V DC).....	3-32
Figure 3-33 Height-unrestricted scenario (+24 V DC).....	3-33

Figure 3-34 Height-unrestricted triple-mode scenario (+24 V DC).....	3-34
Figure 3-35 Installation of the DC RRUs on the IFS06.....	3-35
Figure 3-36 Dimensions of the IFS06.....	3-36
Figure 3-37 Dimensions of the IMB03.....	3-36
Figure 3-38 Recommended clearance for the ICR (DC-RRU-based).....	3-37
Figure 3-39 Recommended clearance for the ICR (AC-RRU-based).....	3-38
Figure 3-40 Minimum clearance for the ICR in the height-unrestricted scenario.....	3-39
Figure 3-41 Minimum clearance for the ICR in the height-restricted scenario.....	3-40
Figure 3-42 Minimum clearance for the ICR (AC-RRU-based).....	3-41
Figure 3-43 Clearance requirements for combined cabinets.....	3-42
Figure 5-1 Obtaining the ESN (1).....	5-1
Figure 5-2 Obtaining the ESN (2).....	5-2
Figure 6-1 Installation process.....	6-2
Figure 7-1 Installing the rear feet.....	7-1
Figure 7-2 Installing the front feet.....	7-2
Figure 7-3 Moving down the adjustable beam.....	7-3
Figure 7-4 Installing the cable rack.....	7-4
Figure 7-5 Installing the adapting piece for the GPS surge protector.....	7-5
Figure 8-1 Marking anchor points.....	8-2
Figure 8-2 Drilling holes.....	8-3
Figure 8-3 Assembling an expansion bolt.....	8-3
Figure 8-4 Installing an expansion bolt.....	8-4
Figure 8-5 Removing a bolt.....	8-4
Figure 8-6 Installing the bolts.....	8-4
Figure 8-7 Pre-tightening the bolts.....	8-5
Figure 8-8 Checking and adjusting the level of the IFS06.....	8-5
Figure 8-9 Tightening the bolts.....	8-6
Figure 8-10 Support for installing the ESD floor.....	8-6
Figure 8-11 Marking anchor points.....	8-7
Figure 8-12 Drilling holes.....	8-8
Figure 8-13 Installing the support.....	8-8
Figure 8-14 Removing the bolts.....	8-9
Figure 8-15 Install the IFS06.....	8-10
Figure 8-16 Pre-tightening the bolts.....	8-10
Figure 8-17 Checking and adjusting the level of the ICR.....	8-11
Figure 8-18 Tightening the bolts.....	8-11
Figure 9-1 Main and auxiliary brackets for the RRU.....	9-1
Figure 9-2 Installing the main bracket in the height-unrestricted scenario.....	9-2
Figure 9-3 Installing the main bracket in the height-restricted scenario.....	9-3
Figure 9-4 Installing the main bracket in the height-unrestricted scenario.....	9-4
Figure 9-5 Installing the main bracket in the height-restricted scenario.....	9-5
Figure 10-1 GPS surge protector.....	10-1

Figure 10-2 Removing the insert nut and toothed washer.....	10-2
Figure 10-3 Installing the connector.....	10-2
Figure 10-4 Installing the GPS surge protector.....	10-2
Figure 10-5 Installing the PGND cable for the GPS surge protector.....	10-3
Figure 11-1 Removing the protection plates.....	11-2
Figure 11-2 Installing mounting ears horizontally.....	11-2
Figure 11-3 Securing the IMB03 to the feet of the ICR.....	11-3
Figure 11-4 Removing the protection plates.....	11-4
Figure 11-5 Installing mounting ears vertically.....	11-4
Figure 11-6 Securing the IMB03 on the feet of the ICR.....	11-5
Figure 11-7 Removing the protection plates from the lower-level IMB03.....	11-5
Figure 11-8 Installing mounting ears vertically.....	11-6
Figure 11-9 Securing the IMB03 to the feet of the ICR.....	11-6
Figure 11-10 Removing the protection plates from the upper-level IMB03.....	11-7
Figure 11-11 Installing mounting ears horizontally on the upper-level IMB03.....	11-7
Figure 11-12 Securing the IMB03 to the feet of the ICR.....	11-8
Figure 12-1 Installation of the equipotential cable and PGND cable.....	12-2
Figure 13-1 Configurations of the slots in the IMB03.....	13-1
Figure 13-2 Removing the mounting ears.....	13-2
Figure 13-3 Installing the mounting ears reversely.....	13-2
Figure 13-4 Installing the BBU into the slot in the IMB03.....	13-3
Figure 13-5 Installing the DCDU-03B into the slot in the IMB03.....	13-4
Figure 13-6 Installing the PGND cable for the DCDU-03B.....	13-4
Figure 13-7 Reinstalling the mounting ears.....	13-5
Figure 13-8 Installing the power equipment (DC/DC) in the IMB03.....	13-5
Figure 13-9 Installing the PGND cable for the power equipment (DC/DC).....	13-6
Figure 13-10 Installing the power equipment (AC/DC) in the IMB03.....	13-7
Figure 13-11 Installing the PGND cable for the power equipment (AC/DC).....	13-8
Figure 14-1 Removing the adapting piece and cover plate.....	14-2
Figure 14-2 Removing the screws.....	14-3
Figure 14-3 Reinstalling the adapting piece and cover plate.....	14-3
Figure 14-4 Connecting the PGND cable for the RRU to the wiring terminal at the bottom.....	14-4
Figure 14-5 Installing the RRU on the main bracket.....	14-4
Figure 14-6 Installing six RRUs.....	14-5
Figure 14-7 Connecting the PGND cable for the RRU to the wiring terminal at the bottom.....	14-6
Figure 14-8 Installing the AC RRU on the main bracket.....	14-7
Figure 15-1 Cable connections (-48 V DC, six RRU3008s).....	15-6
Figure 15-2 Cable connections (-48 V DC, six RRU3804s).....	15-7
Figure 15-3 Cable connections (-48 V DC, six RRU3201s).....	15-9
Figure 15-4 Cable connections (-48 V DC, six RRU3908s).....	15-11
Figure 15-5 Cable connections in the dual-mode scenario (-48 V, three RRU3908s + three RRU3804s).....	15-13
Figure 15-6 Cable Connections in triple-mode scenario (-48 V DC, Three RRU3908s + Three RRU3804s)	15-15

Figure 15-7 Cable connections (-48 V DC, three RRU3008s+three RRU3804s).....	15-17
Figure 15-8 Cable connections in the dual-mode scenario (-48 V, three RRU3908s + three RRU3201s).....	15-19
Figure 15-9 Cable connections in the triple-mode scenario (-48 V, three RRU3908s + three RRU3201s).....	15-21
Figure 15-10 Cable connections (-48 V DC, three RRU3008s+three RRU3201s).....	15-23
Figure 15-11 Cable connections (-48 V DC, three RRU3804s+three RRU3201s).....	15-25
Figure 15-12 Cable connections (-48 V DC, six RRU3008s+six RRU3804s).....	15-27
Figure 15-13 Cable connections in the dual-mode scenario (-48 V, six RRU3908s + six RRU3804s).....	15-29
Figure 15-14 Cable connections in the GSM+LTE scenario (-48 V, six RRU3908s).....	15-31
Figure 15-15 Cable connections in the UMTS Only scenario (-48 V, six RRU3804s).....	15-32
Figure 15-16 Cable connections in the dual-mode scenario (-48 V, six RRU3908s + six RRU3201s).....	15-34
Figure 15-17 Cable connections in the GSM+UMTS Only scenario (-48 V DC, six RRU3908s).....	15-36
Figure 15-18 Cable connections in the LTE Only scenario (-48 V DC, six RRU3201s).....	15-38
Figure 15-19 Cable connections (-48 V DC, six RRU3008s+six RRU3201s).....	15-40
Figure 15-20 Cable connections (-48 V DC, six RRU3804s+six RRU3201s).....	15-42
Figure 15-21 Cable connections (AC RRU).....	15-43
Figure 15-22 Cable connections (220 V AC).....	15-45
Figure 15-23 Cable connections (+24 V DC).....	15-46
Figure 15-24 Process of installing the ICR-related cables.....	15-47
Figure 15-25 Cable routes.....	15-48
Figure 15-26 Connections of the PGND cables for the DC RRU.....	15-49
Figure 15-27 Connections of the PGND cables for the AC RRU.....	15-50
Figure 15-28 Installing the power cable for the BBU.....	15-51
Figure 15-29 Installing the input power cable.....	15-53
Figure 15-30 Installing the power cable and monitoring signal cable (+24 V DC).....	15-55
Figure 15-31 Installing the power cable and monitoring signal cable (220 V AC).....	15-56
Figure 15-32 Connections of the power cable for the DC RRU.....	15-57
Figure 15-33 Connections of the power cable for the AC RRU.....	15-59
Figure 15-34 Connections of the E1/T1 cable.....	15-60
Figure 15-35 Installing the optical module.....	15-61
Figure 15-36 Connections of the CPRI optical cable for six DC RRUs.....	15-62
Figure 15-37 Connections of the CPRI optical cable for 12 DC RRUs.....	15-63
Figure 15-38 Installing the optical module.....	15-63
Figure 15-39 Connections of the CPRI optical cable for AC RRUs.....	15-64
Figure 15-40 Connections of the antenna jumper for the DC RRU.....	15-66
Figure 15-41 Connections of the antenna jumper for the AC RRU.....	15-67
Figure 15-42 GPS clock signal cable.....	15-68
Figure 17-1 BBU power-on check process.....	17-2
Figure 17-2 RRU power-on check process.....	17-3
Figure 18-1 Installing the cover plate.....	18-1
Figure 18-2 Securing the cover plate.....	18-2

Tables

Table 3-1 Installation of three RRUs (on the lower part of the IFS06 by default).....	3-7
Table 3-2 Installation of 6 RRUs (in GSM+UMTS mode).....	3-8
Table 3-3 Installation of 6 RRUs (in GSM+LTE mode).....	3-8
Table 3-4 Installation of 6 RRUs (in UMTS+LTE mode).....	3-9
Table 3-5 Installation of 12 RRUs (in GSM+UMTS mode).....	3-9
Table 3-6 Installation of 12 RRUs (in GSM+LTE mode).....	3-9
Table 3-7 Installation of 12 RRUs (in UMTS+LTE mode).....	3-10
Table 3-8 Installation of three RRUs (on the lower part of the IFS06 by default).....	3-11
Table 3-9 Installation of 6 RRUs (in GSM+UMTS mode).....	3-12
Table 3-10 Installation of 6 RRUs (in GSM+LTE mode).....	3-12
Table 3-11 Installation of 6 RRUs (in UMTS+LTE mode).....	3-13
Table 3-12 Installation of three RRUs (on the lower part of the IFS06 by default).....	3-15
Table 3-13 Installation of 6 RRUs (in GSM+UMTS mode).....	3-16
Table 3-14 Installation of 6 RRUs (in GSM+LTE mode).....	3-16
Table 3-15 Installation of 6 RRUs (in UMTS+LTE mode).....	3-17
Table 3-16 Installation of three RRUs (on the lower part of the IFS06 by default).....	3-19
Table 3-17 Installation of 6 RRUs (in GSM+UMTS mode).....	3-20
Table 3-18 Installation of 6 RRUs (in GSM+LTE mode).....	3-20
Table 3-19 Installation of 6 RRUs (in UMTS+LTE mode).....	3-21
Table 3-20 Installation of six RRUs (in GSM+UMTS+LTE mode).....	3-21
Table 3-21 Installation of 12 RRUs (in GSM+UMTS mode).....	3-22
Table 3-22 Installation of 12 RRUs (in GSM+LTE mode).....	3-22
Table 3-23 Installation of 12 RRUs (in UMTS+LTE mode).....	3-22
Table 3-24 Installation of six RRUs (in GSM+UMTS+LTE mode).....	3-23
Table 3-25 Installation of three RRUs (on the lower part of the IFS06 by default).....	3-25
Table 3-26 Installation of 6 RRUs (in GSM+UMTS mode).....	3-26
Table 3-27 Installation of 6 RRUs (in GSM+LTE mode).....	3-26
Table 3-28 Installation of 6 RRUs (in UMTS+LTE mode).....	3-27
Table 3-29 Installation of 12 RRUs (in GSM+UMTS mode).....	3-27
Table 3-30 Installation of 12 RRUs (in GSM+LTE mode).....	3-27
Table 3-31 Installation of 12 RRUs (in UMTS+LTE mode).....	3-28
Table 3-32 Installation of six RRUs (in GSM+UMTS+LTE mode).....	3-28
Table 3-33 Installation of three RRUs (on the lower part of the IFS06 by default).....	3-31

Table 3-34 Installation of 6 RRUs (in GSM+UMTS mode).....	3-32
Table 3-35 Installation of 6 RRUs (in GSM+LTE mode).....	3-32
Table 3-36 Installation of 6 RRUs (in UMTS+LTE mode).....	3-33
Table 3-37 Installation of 12 RRUs (in GSM+UMTS mode).....	3-33
Table 3-38 Installation of 12 RRUs (in GSM+LTE mode).....	3-33
Table 3-39 Installation of 12 RRUs (in UMTS+LTE mode).....	3-34
Table 3-40 Installation of 12 RRUs (in GSM+UMTS+LTE mode).....	3-34
Table 15-1 Cable description.....	15-6
Table 15-2 Cable description.....	15-8
Table 15-3 Cable description.....	15-10
Table 15-4 Cable description.....	15-11
Table 15-5 Cable description.....	15-13
Table 15-6 Cable description.....	15-16
Table 15-7 Cable description.....	15-18
Table 15-8 Cable description.....	15-19
Table 15-9 Cable description.....	15-22
Table 15-10 Cable description.....	15-23
Table 15-11 Cable description.....	15-25
Table 15-12 Cable description.....	15-28
Table 15-13 Cable description.....	15-30
Table 15-14 Cable description.....	15-31
Table 15-15 Cable description.....	15-33
Table 15-16 Cable description.....	15-35
Table 15-17 Cable description.....	15-36
Table 15-18 Cable description.....	15-39
Table 15-19 Cable description.....	15-41
Table 15-20 Cable description.....	15-43
Table 15-21 Cable description.....	15-44
Table 16-1 Hardware installation checklist.....	16-1

1 Changes in the DBS3900 (ICR) Installation Guide

01 (2011-03-30)

This is the first official release.

Compared with Draft A (2011-01-30), no content is changed.

Compared with Draft A (2011-01-30), no content is added.

Compared with Draft A (2011-01-30), no content is deleted.

Draft A (2011-01-30)

This is the draft issue.

Compared with MBTS V100R003C00, WCDMA-NodeB V200R012C00, GSM-BTS V100R012C00 and eNodeB V100R002C00, , this issue incorporates the following changes:

Content	Change Description
3.2 Installation Options	The structure of the section is changed.

Compared with MBTS V100R003C00, WCDMA-NodeB V200R012C00, GSM-BTS V100R012C00 and eNodeB V100R002C00, this issue is added with the following topics:

- The triple-mode installation scenario is added.
- The cable connections in the triple-mode installation scenario is added.

Compared with MBTS V100R003C00, WCDMA-NodeB V200R012C00, GSM-BTS V100R012C00 and eNodeB V100R002C00, no content is deleted.

2 Installation Preparations

About This Chapter

This chapter describes the tools and instruments required for installation and the skills and prerequisites required for onsite installation engineers.

[2.1 Making Documents Available](#)

Before installing the DBS3900, obtain related information from the following document:

[2.2 Tools and Instruments](#)

This section describes the tools and instruments required for installation.

[2.3 Skills and Requirements for Onsite Personnel](#)

Onsite personnel must be qualified and trained. Before performing any operation, onsite personnel must be familiar with correct operation methods and safety precautions.













2.1 Making Documents Available



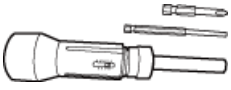
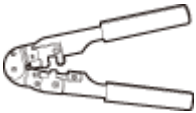

Before installing the DBS3900, obtain related information from the following document:

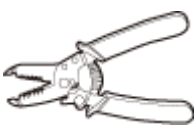
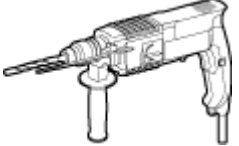
- Installation Reference
- BBU3900 Hardware Description
- BBU3900 Hardware Maintenance Guide

2.2 Tools and Instruments

This section describes the tools and instruments required for installation.

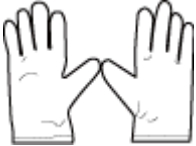
Marker 	Phillips screwdriver (M4, M5, M6, and M8)  Flat-head screwdriver (M4, M5, M6, and M8) 	Diagonal pliers 
Adjustable wrench (capacity ≤ 19 mm) 	Socket wrench (M10 and M12) 	Torque wrench (30 N·m to 50 N·m) 
Phillips torque screwdriver 	Crimping tool 	Wire clippers 
Rubber mallet 	Guarded blade utility knife 	Wire stripper 
Hammer drill ($\varnothing 16$) 	Heat gun 	Level 

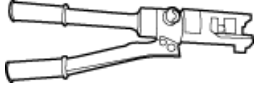
<p>Multimeter</p> 	<p>Measuring tape</p> 	<p>Vacuum cleaner</p> 
<p>ESD gloves</p> 	<p>ESD wrist strap</p> 	<p>Hydraulic pliers</p> 

2.3 Skills and Requirements for Onsite Personnel

Onsite personnel must be qualified and trained. Before performing any operation, onsite personnel must be familiar with correct operation methods and safety precautions.

Before the installation, pay attention to the following items:

- The customer's technical engineers must be trained by Huawei and be familiar with the proper installation and operation methods.
- The number of onsite personnel depends on the engineering schedule and installation environment. Generally, only three to five onsite personnel are necessary.

3 Information About the Installation

About This Chapter

This chapter describes the information about the installation, including exterior, installation scenario, and space requirements

[3.1 Overview of Devices](#)

This chapter describes the devices involved in the installation of the DBS3900.

[3.2 Installation Options](#)

The installation options vary according to height-restricted and height-unrestricted scenarios.

[3.3 Dimensions and Installation Clearance Requirements](#)

This section describes the dimensions and installation clearance requirements for the relevant devices.

3.1 Overview of Devices

This chapter describes the devices involved in the installation of the DBS3900.

IFS06

The IFS06 is an Indoor Floor Installation Support (IFS). It is used for installing DBS3900 devices in a centralized manner.

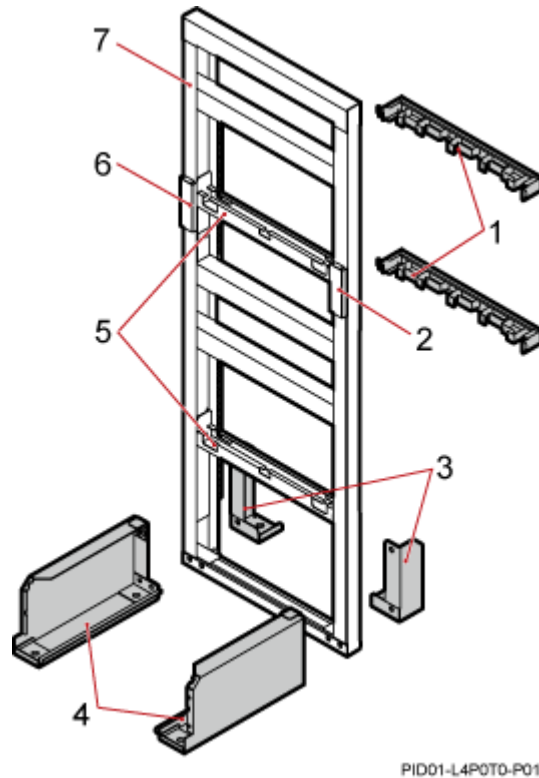

PID01-L4P0T0-P01

- | | | | |
|---------------------|------------------|----------------|----------------|
| (1) Cable rack | (2) Ground bar 2 | (3) Rear foot | (4) Front foot |
| (5) Adjustable beam | (6) Ground bar 1 | (7) Main frame | - |

NOTE

In this document, the cable colors and exteriors of the devices are for reference only.

IMB03

The IMB03 is an Indoor Mini Box (IMB). It is used for installing the BBU and power devices.

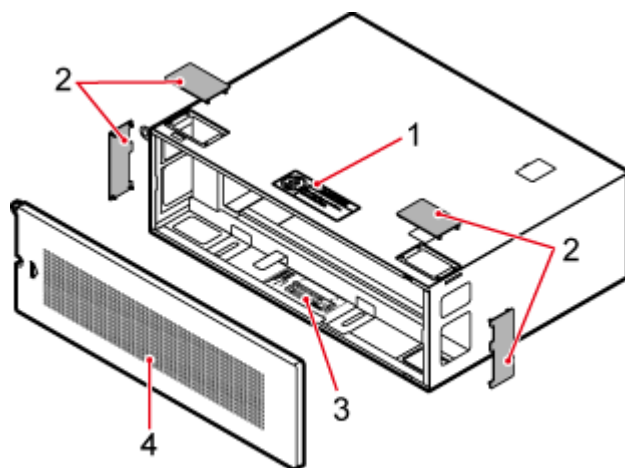

PID02-L4P0T0-P01

- (1) NO STEPPING sign
- (3) Slot assignment label

- (2) Protection plate
- (4) Cover plate

Other Devices

Figure 3-1 DCDU-03B

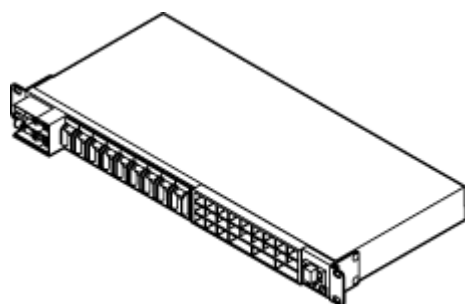

PID06-L4P0T0-P01

Figure 3-2 BBU3900

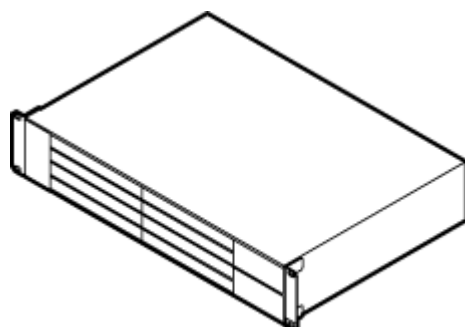

PID04-L4P0T0-P01

Figure 3-3 RRU

PID03-L0P0T0-P01

**WARNING**

- Place the foam pad or cardboard under the RRU to prevent any damage to the housing of the RRU.
 - The load-bearing capacity of the RF ports at the bottom of the RRU is low. Do not stand the RRU upright.
-

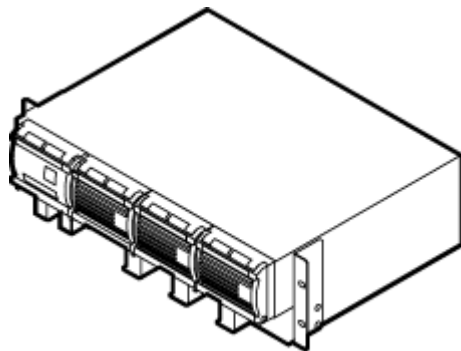
Figure 3-4 Power equipment (AC/DC)

PID07-L0P0T0-P01

Figure 3-5 Power equipment (DC/DC)

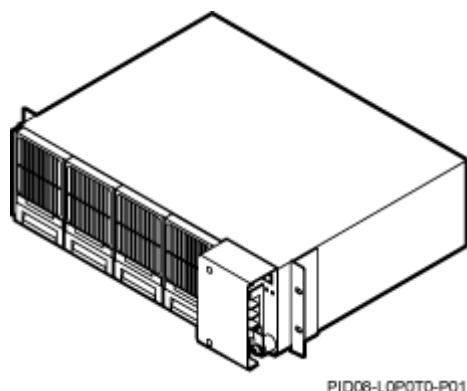

3.2 Installation Options

The installation options vary according to height-restricted and height-unrestricted scenarios.

 **NOTE**

The ICR is an indoor centralized rack, integrating the IFS06 with the IMB03.

The IFS06 is an indoor floor installation support.

The IMB03 is an indoor mini box.

3.2.1 Height-Restricted Scenario

This section describes the installation of the DBS3900 on the ICR in the height-restricted scenario.

3.2.2 Height-Unrestricted Scenario

This section describes the installation of the DBS3900 on the ICR in the height-unrestricted scenario.

3.2.1 Height-Restricted Scenario

This section describes the installation of the DBS3900 on the ICR in the height-restricted scenario.

In the scenario where a cable rack is 1.8 m to 2 m above the floor (hereinafter referred to as the height-restricted scenario), the RRUs are installed on beam 2 and beam 4, as shown in [Figure 3-6](#).

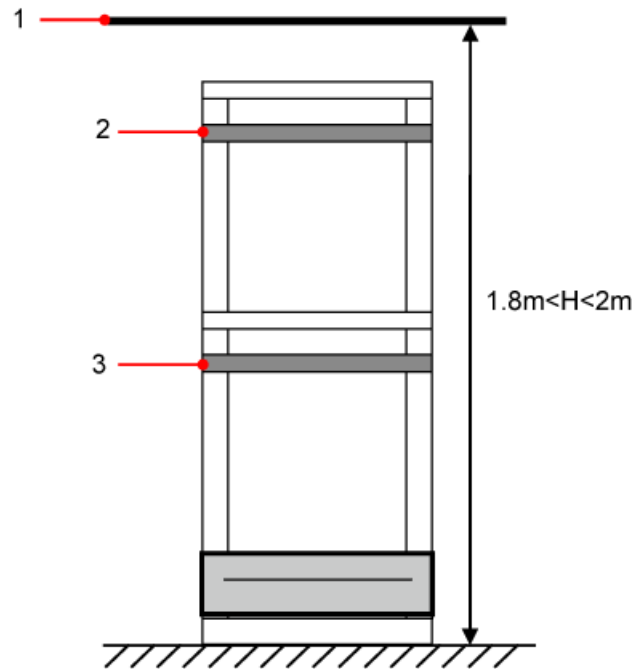
Figure 3-6 Height-restricted scenario

ISD09-L1P0T0-P02

(1) Cable rack

(2) Beam 2

(3) Beam 4

Height-Restricted Scenario (-48 V)

This section describes the -48 V height-restricted scenario. In this scenario, RRUs can be installed on the IFS06 with the IMB03 or on the IFS06 independently.

RRU and IMB03 combination installation scenario (IFS06+IMB03+RRU)

In this scenario, three RRUs, six RRUs, or 12 RRUs are installed.

- IFS06+IMB03+RRU (Three DC RRUs)

Figure 3-7 Height-restricted scenario (-48 V DC)

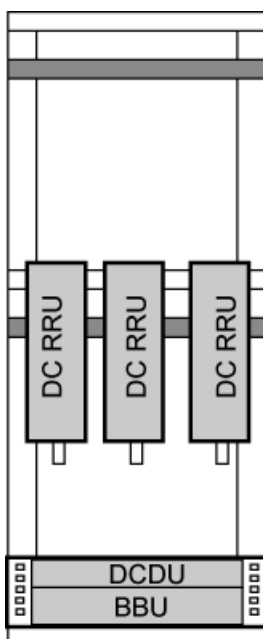

ISD09-L0P0T0-P01

Table 3-1 Installation of three RRUs (on the lower part of the IFS06 by default)

Position	GSM Mode	UMTS Mode	LTE Mode	GSM+UMTS/ GSM+LTE
Lower part	Three RRU3008s, or three RRU3004s	Three RRU3804s, three RRU3801Es, three RRU3806s, three RRU3808s, or three RRU3805s	Three RRU3201s, three RRU3211s, three RRU3203s, three RRU3233s, three RRU3222s, or three RRU3232s	Three RRU3908s, or three RRU3920s

NOTE

The RRU3008, and RRU3004 support the GSM mode. The following description is based on the RRU3008.
 The RRU3804, RRU3801E, RRU3806, RRU3808, and RRU3805 support the UMTS mode. The following description is based on the RRU3804.
 The RRU3201, RRU3211, RRU3203, RRU3233, RRU3222, and RRU3232 support the LTE mode. The following description is based on the RRU3201.
 The RRU3908 and RRU3920 support the multi-mode. The following description is based on the RRU3908.

- IFS06+IMB03+RRU (Six DC RRUs)

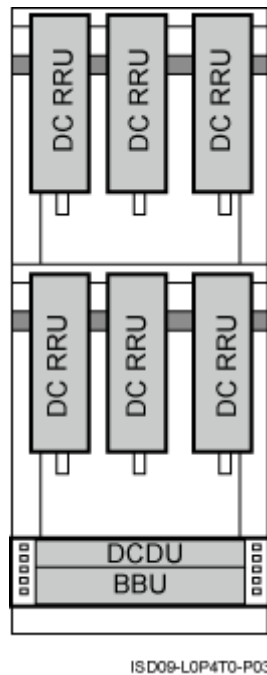
Figure 3-8 Height-restricted scenario (-48 V DC)**Table 3-2** Installation of 6 RRUs (in GSM+UMTS mode)

Position	GSM Mode	UMTS Mode	GSM +UMTS Mode	GSM +UMTS Hybrid Co-Cabinet	GSM +UMTS Co-Cabinet
Upper part	Three RRU3008s	Three RRU3804s	Three RRU3908s	Three RRU3908s	Three RRU3008s
Lower part	Three RRU3008s	Three RRU3804s	Three RRU3908s	Three RRU3804s	Three RRU3804s

Table 3-3 Installation of 6 RRUs (in GSM+LTE mode)

Position	GSM Mode	LTE Mode	GSM+LTE Hybrid Co-Cabinet	GSM+LTE Co-Cabinet
Upper part	Three RRU3008s	Three RRU3201s	Three RRU3908s	Three RRU3008s
Lower part	Three RRU3008s	Three RRU3201s	Three RRU3201s	Three RRU3201s

Table 3-4 Installation of 6 RRUs (in UMTS+LTE mode)

Position	UMTS Mode	LTE Mode	UMTS+LTE Co-Cabinet
Upper part	Three RRU3804s	Three RRU3201s	Three RRU3804s
Lower part	Three RRU3804s	Three RRU3201s	Three RRU3201s

- IFS06+IMB03+RRU (12 DC RRUs)

Figure 3-9 Height-restricted scenario (-48 V DC)

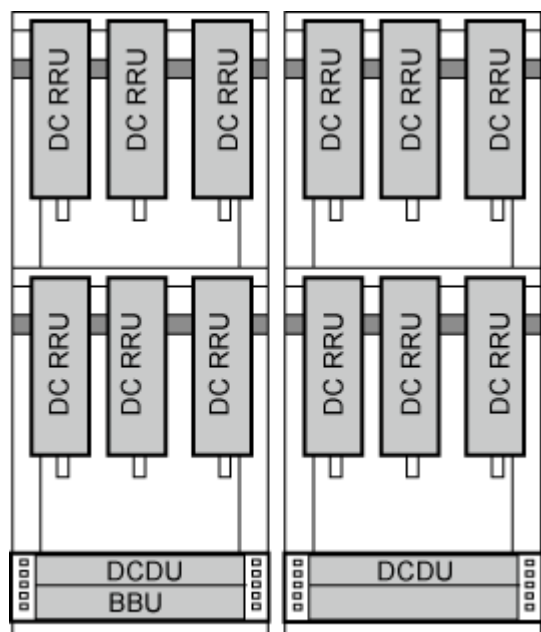

Table 3-5 Installation of 12 RRUs (in GSM+UMTS mode)

Position	GSM+UMTS Hybrid Co-Cabinet	GSM+UMTS Co-Cabinet
ICR1	Six RRU3908s	Six RRU3008s
ICR2	Six RRU3804s	Six RRU3804s

Table 3-6 Installation of 12 RRUs (in GSM+LTE mode)

Position	GSM+UMTS Hybrid Co-Cabinet	GSM+UMTS Co-Cabinet
ICR1	Six RRU3908s	Six RRU3008s
ICR2	Six RRU3201s	Six RRU3201s

Table 3-7 Installation of 12 RRUs (in UMTS+LTE mode)

Position	UMTS+LTE Co-Cabinet
ICR1	Six RRU3804s
ICR2	Six RRU3201s

Independent RRU installation scenario (IFS06+RRU)

In this scenario, three RRUs or six RRUs are installed. The configurations and installations of the RRUs in the IFS06+RRU scenario and in the IFS06+IMB03+RRU scenario are the same. For details, see [RRU and IMB03 combination installation scenario \(IFS06+IMB03+RRU\)](#). **Figure 3-10** takes the installation of six RRUs as an example.

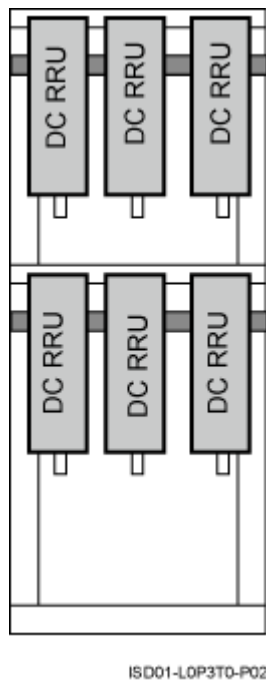
Figure 3-10 Installation of the DC RRUs on the IFS06

Height-Restricted Scenario (220 V)

This section describes the 220 V height-restricted scenario. In this scenario, RRUs can be installed on the IFS06 with the IMB03 or on the IFS06 independently.

RRU and IMB03 combination installation scenario (IFS06+IMB03+RRU)

In this scenario, three RRUs or six RRUs are installed.

- IFS06+IMB03+RRU (Three DC RRUs)

Figure 3-11 Height-restricted scenario (220 V AC)

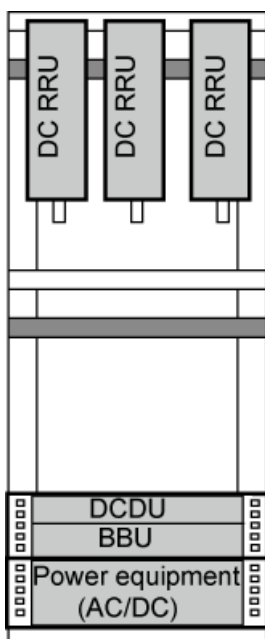

ISD09-L0P0T0-P02

Table 3-8 Installation of three RRUs (on the lower part of the IFS06 by default)

Position	GSM Mode	UMTS Mode	LTE Mode	GSM+UMTS/ GSM+LTE
Upper part	Three RRU3008s, or three RRU3004s	Three RRU3804s, three RRU3801Es, three RRU3806s, three RRU3808s, or three RRU3805s	Three RRU3201s, three RRU3211s, three RRU3203s, three RRU3233s, three RRU3222s, or three RRU3232s	Three RRU3908s, or three RRU3920s

NOTE

The RRU3008, and RRU3004 support the GSM mode. The following description is based on the RRU3008.
 The RRU3804, RRU3801E, RRU3806, RRU3808, and RRU3805 support the UMTS mode. The following description is based on the RRU3804.
 The RRU3201, RRU3211, RRU3203, RRU3233, RRU3222, and RRU3232 support the LTE mode. The following description is based on the RRU3201.
 The RRU3908 and RRU3920 support the multi-mode. The following description is based on the RRU3908.

- IFS06+IMB03+RRU (Six DC RRUs)

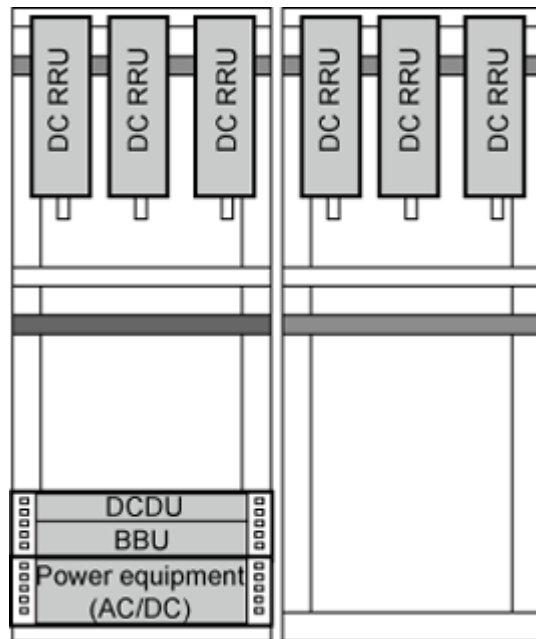
Figure 3-12 Height-restricted scenario (220 V AC)

ISD09-L0P1T0-P01

Table 3-9 Installation of 6 RRUs (in GSM+UMTS mode)

Position	GSM Mode	UMTS Mode	GSM +UMTS Mode	GSM +UMTS Hybrid Co-Cabinet	GSM +UMTS Co-Cabinet
ICR1	Three RRU3008s	Three RRU3804s	Three RRU3908s	Three RRU3908s	Three RRU3008s
ICR2	Three RRU3008s	Three RRU3804s	Three RRU3908s	Three RRU3804s	Three RRU3804s

Table 3-10 Installation of 6 RRUs (in GSM+LTE mode)

Position	GSM Mode	LTE Mode	GSM+LTE Hybrid Co-Cabinet	GSM+LTE Co-Cabinet
ICR1	Three RRU3008s	Three RRU3201s	Three RRU3908s	Three RRU3008s
ICR2	Three RRU3008s	Three RRU3201s	Three RRU3201s	Three RRU3201s

Table 3-11 Installation of 6 RRUs (in UMTS+LTE mode)

Position	UMTS Mode	LTE Mode	UMTS+LTE Co-Cabinet
ICR1	Three RRU3804s	Three RRU3201s	Three RRU3804s
ICR2	Three RRU3804s	Three RRU3201s	Three RRU3201s

Independent RRU installation scenario (IFS06+RRU)

- IFS06+RRU (DC RRU)

In this scenario, three RRUs or six RRUs are installed. The configurations and installations of the RRUs in the IFS06+RRU scenario and in the IFS06+IMB03+RRU scenario are the same. For details, see [RRU and IMB03 combination installation scenario \(IFS06+IMB03+RRU\)](#). [Figure 3-13](#) takes the installation of six RRUs as an example.

Figure 3-13 Installation of the DC RRU on the IFS06

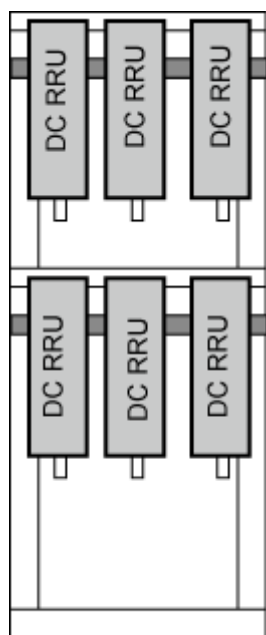

ISD01-L0P3T0-P02

- IFS06+RRU (AC RRU)

[Figure 3-14](#) shows the installation of AC RRUs on the IFS06.

NOTE

The description of the AC RRU in this document is based on the AC RRU3908.

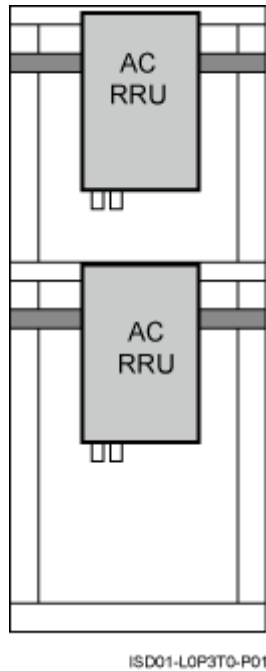
Figure 3-14 Installation of AC RRUs on the IFS06

Height-Restricted Scenario (+24 V)

This section describes the +24 V height-restricted scenario. In this scenario, RRUs can be installed on the IFS06 with the IMB03 or on the IFS06 independently.

RRU and IMB03 combination installation scenario (IFS06+IMB03+RRU)

In this scenario, three RRUs or six RRUs are installed.

- IFS06+IMB03+RRU (Three DC RRUs)

Figure 3-15 Height-restricted scenario (+24 V DC)

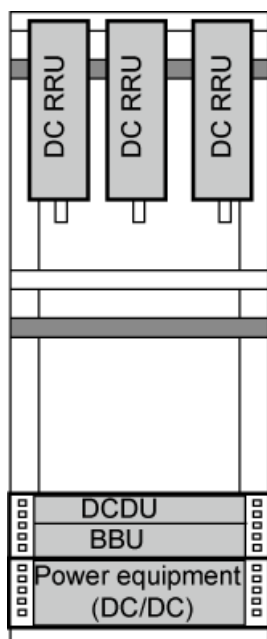

ISD09-L0P0T0-P03

Table 3-12 Installation of three RRUs (on the lower part of the IFS06 by default)

Position	GSM Mode	UMTS Mode	LTE Mode	GSM+UMTS/ GSM+LTE
Upper part	Three RRU3008s, or three RRU3004s	Three RRU3804s, three RRU3801Es, three RRU3806s, three RRU3808s, or three RRU3805s	Three RRU3201s, three RRU3211s, three RRU3203s, three RRU3233s, three RRU3222s, or three RRU3232s	Three RRU3908s, or three RRU3920s

NOTE

The RRU3008, and RRU3004 support the GSM mode. The following description is based on the RRU3008.
 The RRU3804, RRU3801E, RRU3806, RRU3808, and RRU3805 support the UMTS mode. The following description is based on the RRU3804.
 The RRU3201, RRU3211, RRU3203, RRU3233, RRU3222, and RRU3232 support the LTE mode. The following description is based on the RRU3201.
 The RRU3908 and RRU3920 support the multi-mode . The following description is based on the RRU3908.

- IFS06+IMB03+RRU (Six DC RRUs)

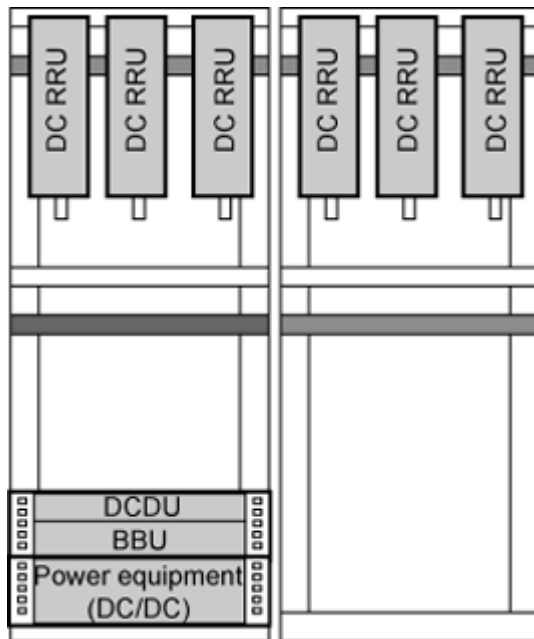
Figure 3-16 Height-restricted scenario (+24 V DC)

ISD09-L0P2T0-P01

Table 3-13 Installation of 6 RRUs (in GSM+UMTS mode)

Position	GSM Mode	UMTS Mode	GSM +UMTS Mode	GSM +UMTS Hybrid Co-Cabinet	GSM +UMTS Co-Cabinet
ICR1	Three RRU3008s	Three RRU3804s	Three RRU3908s	Three RRU3908s	Three RRU3008s
ICR2	Three RRU3008s	Three RRU3804s	Three RRU3908s	Three RRU3804s	Three RRU3804s

Table 3-14 Installation of 6 RRUs (in GSM+LTE mode)

Position	GSM Mode	LTE Mode	GSM+LTE Hybrid Co-Cabinet	GSM+LTE Co-Cabinet
ICR1	Three RRU3008s	Three RRU3201s	Three RRU3908s	Three RRU3008s
ICR2	Three RRU3008s	Three RRU3201s	Three RRU3201s	Three RRU3201s

Table 3-15 Installation of 6 RRUs (in UMTS+LTE mode)

Position	UMTS Mode	LTE Mode	UMTS+LTE Co-Cabinet
ICR1	Three RRU3804s	Three RRU3201s	Three RRU3804s
ICR2	Three RRU3804s	Three RRU3201s	Three RRU3201s

Independent RRU installation scenario (IFS06+RRU)

In this scenario, three RRUs or six RRUs are installed. The configurations and installations of the RRUs in the IFS06+RRU scenario and in the IFS06+IMB03+RRU scenario are the same. For details, see [RRU and IMB03 combination installation scenario \(IFS06+IMB03+RRU\)](#). [Figure 3-17](#) takes the installation of six RRUs as an example.

Figure 3-17 Installation of the DC RRUs on the IFS06

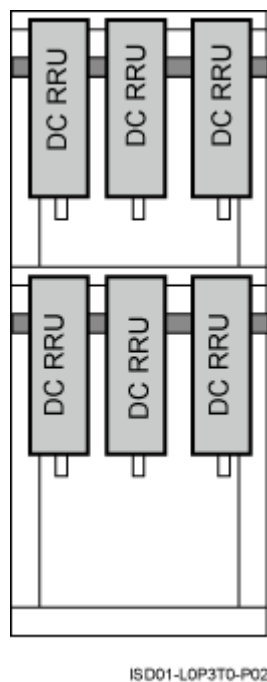

3.2.2 Height-Unrestricted Scenario

This section describes the installation of the DBS3900 on the ICR in the height-unrestricted scenario.

In the scenario where a cable rack is more than 2 m above the floor (hereinafter referred to as the height-unrestricted scenario), the RRUs are installed on beam 1 and beam 3 by default, as shown in [Figure 3-18](#).

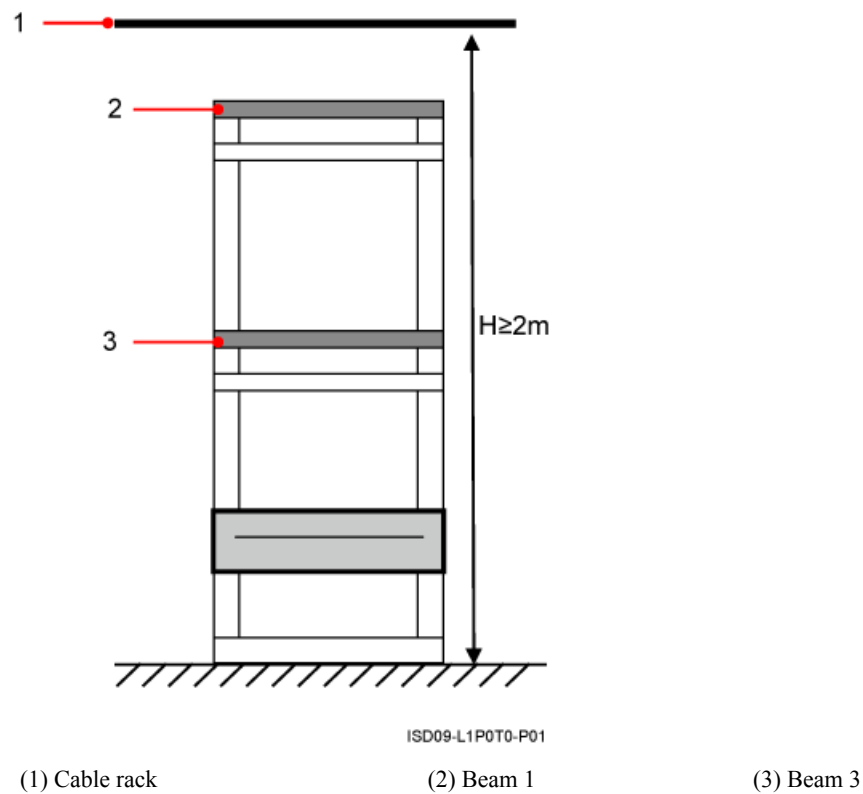
Figure 3-18 Height-unrestricted scenario

Height-Unrestricted Scenario (-48 V)

This section describes the -48 V height-unrestricted scenario. In this scenario, RRUs can be installed on the IFS06 with the IMB03 or on the IFS06 independently.

RRU and IMB03 combination installation scenario (IFS06+IMB03+RRU)

In this scenario, three RRUs, six RRUs, or 12 RRUs are installed.

- IFS06+IMB03+RRU (Three DC RRUs)

Figure 3-19 Height-unrestricted scenario (-48 V DC)

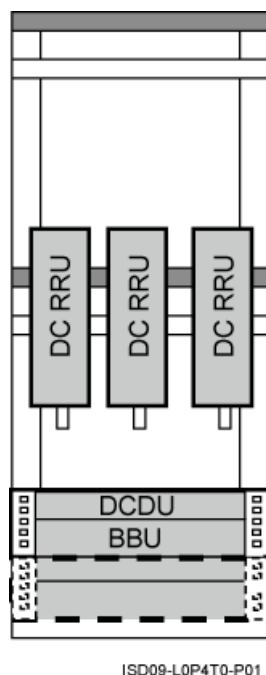

Table 3-16 Installation of three RRUs (on the lower part of the IFS06 by default)

Position	GSM Mode	UMTS Mode	LTE Mode	GSM+UMTS/ GSM+LTE
Lower part	Three RRU3008s, or three RRU3004s	Three RRU3804s, three RRU3801Es, three RRU3806s, three RRU3808s, or three RRU3805s	Three RRU3201s, three RRU3211s, three RRU3203s, three RRU3233s, three RRU3222s, or three RRU3232s	Three RRU3908s, or three RRU3920s

NOTE

The RRU3008, and RRU3004 support the GSM mode. The following description is based on the RRU3008.
 The RRU3804, RRU3801E, RRU3806, RRU3808, and RRU3805 support the UMTS mode. The following description is based on the RRU3804.
 The RRU3201, RRU3211, RRU3203, RRU3233, RRU3222, and RRU3232 support the LTE mode. The following description is based on the RRU3201.
 The RRU3908 and RRU3920 support the multi-mode. The following description is based on the RRU3908.

- IFS06+IMB03+RRU (Six DC RRUs)

Figure 3-20 Height-unrestricted scenario (-48 V DC)

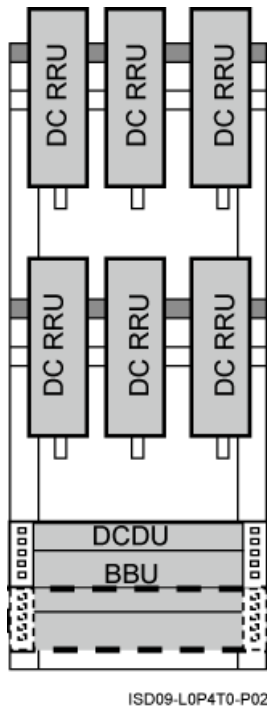

Table 3-17 Installation of 6 RRUs (in GSM+UMTS mode)

Position	GSM Mode	UMTS Mode	GSM +UMTS Mode	GSM +UMTS Hybrid Co-Cabinet	GSM +UMTS Co-Cabinet
Upper part	Three RRU3008s	Three RRU3804s	Three RRU3908s	Three RRU3908s	Three RRU3008s
Lower part	Three RRU3008s	Three RRU3804s	Three RRU3908s	Three RRU3804s	Three RRU3804s

Table 3-18 Installation of 6 RRUs (in GSM+LTE mode)

Position	GSM Mode	LTE Mode	GSM+LTE Hybrid Co-Cabinet	GSM+LTE Co-Cabinet
Upper part	Three RRU3008s	Three RRU3201s	Three RRU3908s	Three RRU3008s
Lower part	Three RRU3008s	Three RRU3201s	Three RRU3201s	Three RRU3201s

Table 3-19 Installation of 6 RRUs (in UMTS+LTE mode)

Position	UMTS Mode	LTE Mode	UMTS+LTE Co-Cabinet
Upper part	Three RRU3804s	Three RRU3201s	Three RRU3804s
Lower part	Three RRU3804s	Three RRU3201s	Three RRU3201s

 **NOTE**

When 6 RRUs are configured, one DCDU and one BBU are added in the triple mode scenario, as shown in [Figure 3-21](#).

Figure 3-21 Height-unrestricted triple-mode scenario (-48 V DC)

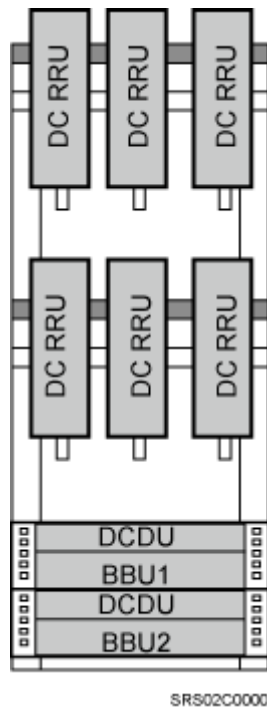
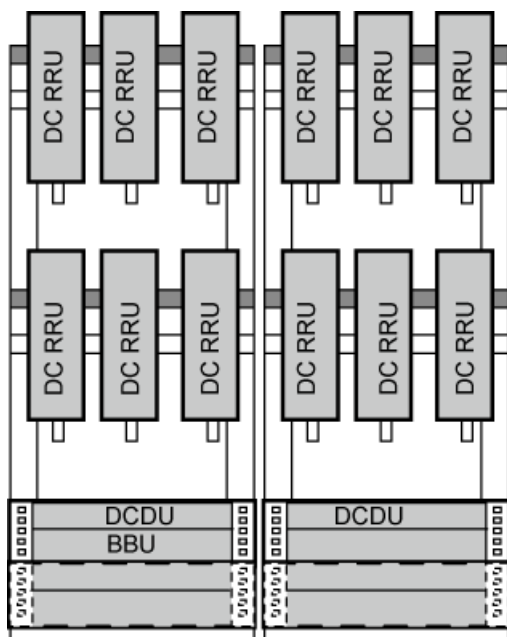

Table 3-20 Installation of six RRUs (in GSM+UMTS+LTE mode)

Position	GU+LTE	GL+UMTS
Upper part	Three RRU3908s	Three RRU3908s
Lower part	Three RRU3201s	Three RRU3804s

- IFS06+IMB03+RRU (12 DC RRUs)

Figure 3-22 Height-unrestricted scenario (-48 V DC)

8269LPT011

Table 3-21 Installation of 12 RRUs (in GSM+UMTS mode)

Position	GSM+UMTS Hybrid Co-Cabinet	GSM+UMTS Co-Cabinet
ICR1	Six RRU3908s	Six RRU3008s
ICR2	Six RRU3804s	Six RRU3804s

Table 3-22 Installation of 12 RRUs (in GSM+LTE mode)

Position	GSM+UMTS Hybrid Co-Cabinet	GSM+UMTS Co-Cabinet
ICR1	Six RRU3908s	Six RRU3008s
ICR2	Six RRU3201s	Six RRU3201s

Table 3-23 Installation of 12 RRUs (in UMTS+LTE mode)

Position	UMTS+LTE Co-Cabinet
ICR1	Six RRU3804s
ICR2	Six RRU3201s

 **NOTE**

When 12 RRUs are configured, one BBU is added in the triple mode scenario, as shown in [Figure 3-23](#).

Figure 3-23 Height-unrestricted triple-mode scenario (-48 V DC)

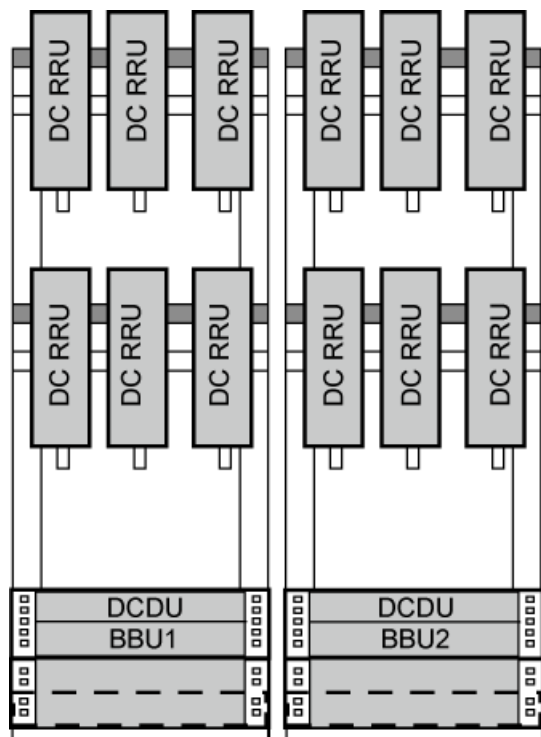

SRS02C0001

Table 3-24 Installation of six RRUs (in GSM+UMTS+LTE mode)

Position	GU+LTE	GL+UMTS
ICR1	Six RRU3908s	Six RRU3908s
ICR2	Six RRU3201s	Six RRU3804s

Independent RRU installation scenario (IFS06+RRU)

In this scenario, three RRUs or six RRUs are installed. The configurations and installations of the RRUs in the IFS06+RRU scenario and in the IFS06+IMB03+RRU scenario are the same. For details, see [RRU and IMB03 combination installation scenario \(IFS06+IMB03+RRU\)](#). [Figure 3-24](#) takes the installation of six RRUs as an example.

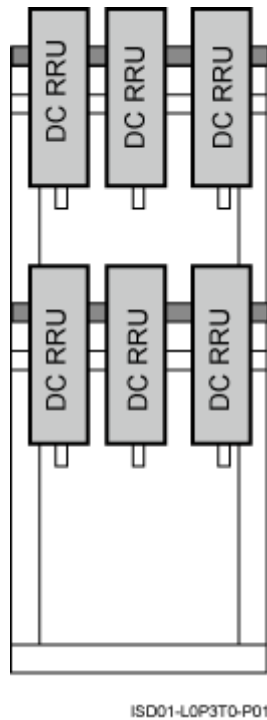
Figure 3-24 Installation of the DC RRUs on the IFS06

Height-Unrestricted Scenario (220 V)

This section describes the 220 V height-unrestricted scenario. In this scenario, RRUs can be installed on the IFS06 with the IMB03 or on the IFS06 independently.

RRU and IMB03 combination installation scenario (IFS06+IMB03+RRU)

In this scenario, three RRUs, six RRUs, or 12 RRUs are installed.

- IFS06+IMB03+RRU (Three DC RRUs)

Figure 3-25 Height-unrestricted scenario (220 V AC)

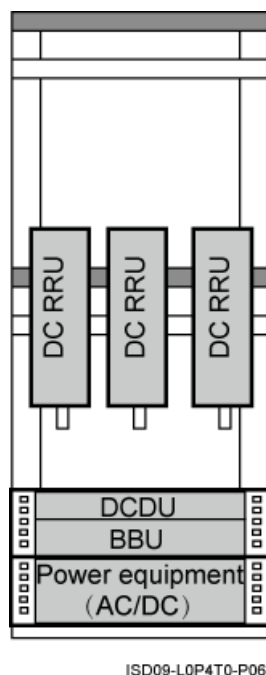

Table 3-25 Installation of three RRUs (on the lower part of the IFS06 by default)

Position	GSM Mode	UMTS Mode	LTE Mode	GSM+UMTS/ GSM+LTE
Lower part	Three RRU3008s, or three RRU3004s	Three RRU3804s, three RRU3801Es, three RRU3806s, three RRU3808s, or three RRU3805s	Three RRU3201s, three RRU3211s, three RRU3203s, three RRU3233s, three RRU3222s, or three RRU3232s	Three RRU3908s, or three RRU3920s

NOTE

The RRU3008, and RRU3004 support the GSM mode. The following description is based on the RRU3008.
 The RRU3804, RRU3801E, RRU3806, RRU3808, and RRU3805 support the UMTS mode. The following description is based on the RRU3804.
 The RRU3201, RRU3211, RRU3203, RRU3233, RRU3222, and RRU3232 support the LTE mode. The following description is based on the RRU3201.
 The RRU3908 and RRU3920 support the multi-mode. The following description is based on the RRU3908.

- IFS06+IMB03+RRU (Three DC RRUs)

Figure 3-26 Height-unrestricted scenario (220 V AC)

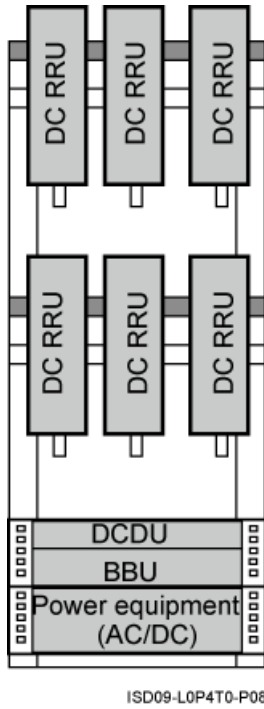

Table 3-26 Installation of 6 RRUs (in GSM+UMTS mode)

Position	GSM Mode	UMTS Mode	GSM +UMTS Mode	GSM +UMTS Hybrid Co-Cabinet	GSM +UMTS Co-Cabinet
Upper part	Three RRU3008s	Three RRU3804s	Three RRU3908s	Three RRU3908s	Three RRU3008s
Lower part	Three RRU3008s	Three RRU3804s	Three RRU3908s	Three RRU3804s	Three RRU3804s

Table 3-27 Installation of 6 RRUs (in GSM+LTE mode)

Position	GSM Mode	LTE Mode	GSM+LTE Hybrid Co-Cabinet	GSM+LTE Co-Cabinet
Upper part	Three RRU3008s	Three RRU3201s	Three RRU3908s	Three RRU3008s
Lower part	Three RRU3008s	Three RRU3201s	Three RRU3201s	Three RRU3201s

Table 3-28 Installation of 6 RRUs (in UMTS+LTE mode)

Position	UMTS Mode	LTE Mode	UMTS+LTE Co-Cabinet
Upper part	Three RRU3804s	Three RRU3201s	Three RRU3804s
Lower part	Three RRU3804s	Three RRU3201s	Three RRU3201s

- IFS06+IMB03+RRU (12 DC RRUs)

Figure 3-27 Height-unrestricted scenario (220 V AC)

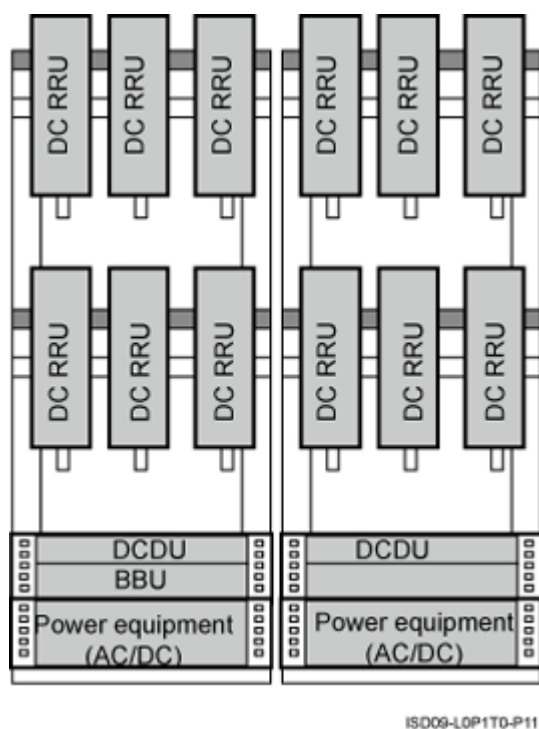

Table 3-29 Installation of 12 RRUs (in GSM+UMTS mode)

Position	GSM+UMTS Hybrid Co-Cabinet	GSM+UMTS Co-Cabinet
ICR1	Six RRU3908s	Six RRU3008s
ICR2	Six RRU3804s	Six RRU3804s

Table 3-30 Installation of 12 RRUs (in GSM+LTE mode)

Position	GSM+UMTS Hybrid Co-Cabinet	GSM+UMTS Co-Cabinet
ICR1	Six RRU3908s	Six RRU3008s

Position	GSM+UMTS Hybrid Co-Cabinet	GSM+UMTS Co-Cabinet
ICR2	Six RRU3201s	Six RRU3201s

Table 3-31 Installation of 12 RRUs (in UMTS+LTE mode)

Position	UMTS+LTE Co-Cabinet
ICR1	Six RRU3804s
ICR2	Six RRU3201s

 **NOTE**

When 12 RRUs are configured, one BBU is added in the triple mode scenario, as shown in [Figure 3-28](#).

Figure 3-28 Height-unrestricted triple-mode scenario (220 V AC)

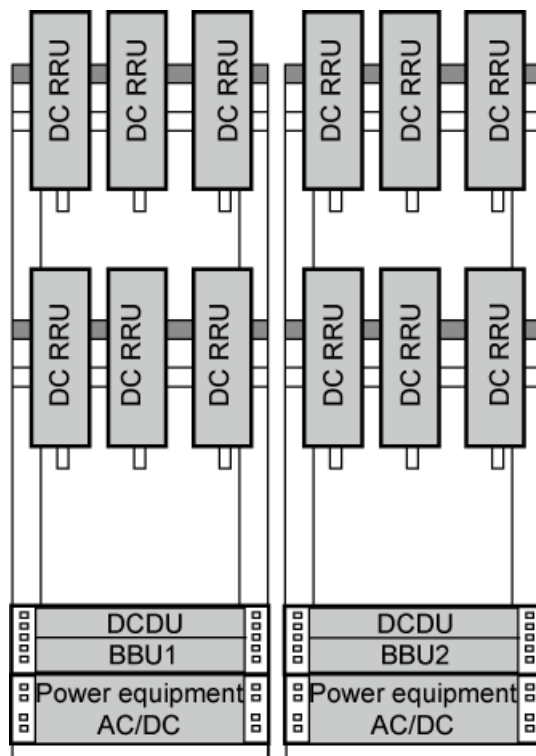

SRS02C0002

Table 3-32 Installation of six RRUs (in GSM+UMTS+LTE mode)

Position	GU+LTE	GL+UMTS
ICR1	Six RRU3908s	Six RRU3908s
ICR2	Six RRU3201s	Six RRU3804s

Independent RRU installation scenario (IFS06+RRU)

- IFS06+RRU (DC RRU)

In this scenario, three RRUs or six RRUs are installed. The configurations and installations of the RRUs in the IFS06+RRU scenario and in the IFS06+IMB03+RRU scenario are the same. For details, see [RRU and IMB03 combination installation scenario \(IFS06+IMB03+RRU\)](#). [Figure 3-29](#) takes the installation of six RRUs as an example.

Figure 3-29 Installation of the DC RRUs on the IFS06

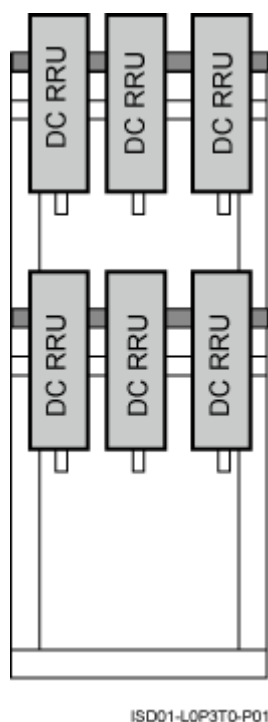

- IFS06+RRU (AC RRU)

[Figure 3-30](#) shows the installation of AC RRUs on the IFS06.

 **NOTE**

The description of the AC RRU in this document is based on the AC RRU3908.

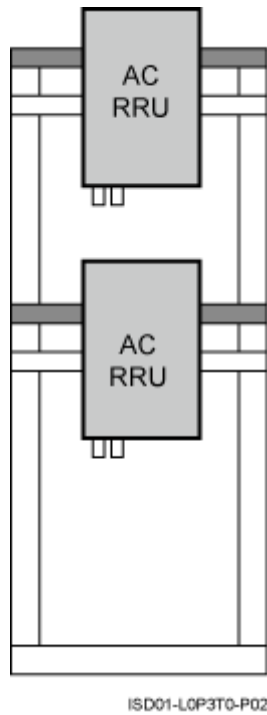
Figure 3-30 Installation of AC RRUs on the IFS06

Height-Unrestricted Scenario (+24 V)

This section describes the +24 V height-unrestricted scenario. In this scenario, RRUs can be installed on the IFS06 with the IMB03 or on the IFS06 independently.

RRU and IMB03 combination installation scenario (IFS06+IMB03+RRU)

In this scenario, three RRUs, six RRUs, or 12 RRUs are installed.

- IFS06+IMB03+RRU (Three DC RRUs)

Figure 3-31 Height-unrestricted scenario (+24 V DC)

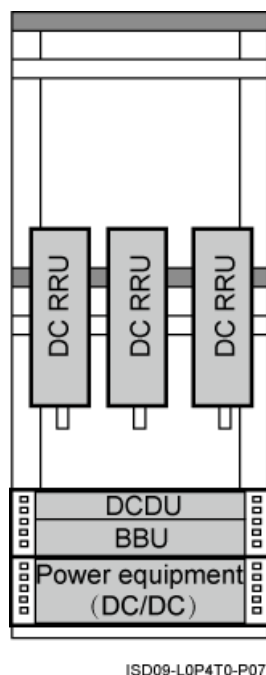

Table 3-33 Installation of three RRUs (on the lower part of the IFS06 by default)

Position	GSM Mode	UMTS Mode	LTE Mode	GSM+UMTS/ GSM+LTE
Lower part	Three RRU3008s, or three RRU3004s	Three RRU3804s, three RRU3801Es, three RRU3806s, three RRU3808s, or three RRU3805s	Three RRU3201s, three RRU3211s, three RRU3203s, three RRU3233s, three RRU3222s, or three RRU3232s	Three RRU3908s, or three RRU3920s

NOTE

The RRU3008, and RRU3004 support the GSM mode. The following description is based on the RRU3008.
 The RRU3804, RRU3801E, RRU3806, RRU3808, and RRU3805 support the UMTS mode. The following description is based on the RRU3804.
 The RRU3201, RRU3211, RRU3203, RRU3233, RRU3222, and RRU3232 support the LTE mode. The following description is based on the RRU3201.
 The RRU3908 and RRU3920 support the multi-mode. The following description is based on the RRU3908.

- IFS06+IMB03+RRU (Six DC RRUs)

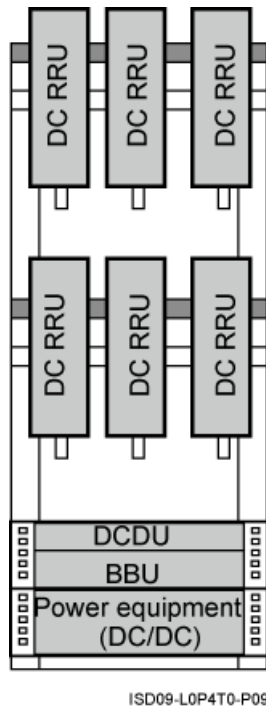
Figure 3-32 Height-unrestricted scenario (+24 V DC)**Table 3-34** Installation of 6 RRUs (in GSM+UMTS mode)

Position	GSM Mode	UMTS Mode	GSM +UMTS Mode	GSM +UMTS Hybrid Co-Cabinet	GSM +UMTS Co-Cabinet
Upper part	Three RRU3008s	Three RRU3804s	Three RRU3908s	Three RRU3908s	Three RRU3008s
Lower part	Three RRU3008s	Three RRU3804s	Three RRU3908s	Three RRU3804s	Three RRU3804s

Table 3-35 Installation of 6 RRUs (in GSM+LTE mode)

Position	GSM Mode	LTE Mode	GSM+LTE Hybrid Co-Cabinet	GSM+LTE Co-Cabinet
Upper part	Three RRU3008s	Three RRU3201s	Three RRU3908s	Three RRU3008s
Lower part	Three RRU3008s	Three RRU3201s	Three RRU3201s	Three RRU3201s

Table 3-36 Installation of 6 RRUs (in UMTS+LTE mode)

Position	UMTS Mode	LTE Mode	UMTS+LTE Co-Cabinet
Upper part	Three RRU3804s	Three RRU3201s	Three RRU3804s
Lower part	Three RRU3804s	Three RRU3201s	Three RRU3201s

- IFS06+IMB03+RRU (12 DC RRUs)

Figure 3-33 Height-unrestricted scenario (+24 V DC)

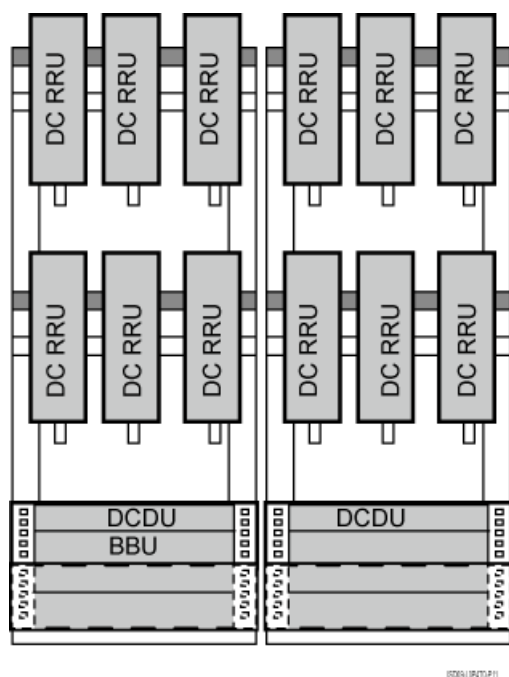

Table 3-37 Installation of 12 RRUs (in GSM+UMTS mode)

Position	GSM+UMTS Hybrid Co-Cabinet	GSM+UMTS Co-Cabinet
ICR1	Six RRU3908s	Six RRU3008s
ICR2	Six RRU3804s	Six RRU3804s

Table 3-38 Installation of 12 RRUs (in GSM+LTE mode)

Position	GSM+UMTS Hybrid Co-Cabinet	GSM+UMTS Co-Cabinet
ICR1	Six RRU3908s	Six RRU3008s
ICR2	Six RRU3201s	Six RRU3201s

Table 3-39 Installation of 12 RRUs (in UMTS+LTE mode)

Position	UMTS+LTE Co-Cabinet
ICR1	Six RRU3804s
ICR2	Six RRU3201s

 **NOTE**

When 12 RRUs are configured, one BBU is added in the triple mode scenario, as shown in [Figure 3-34](#).

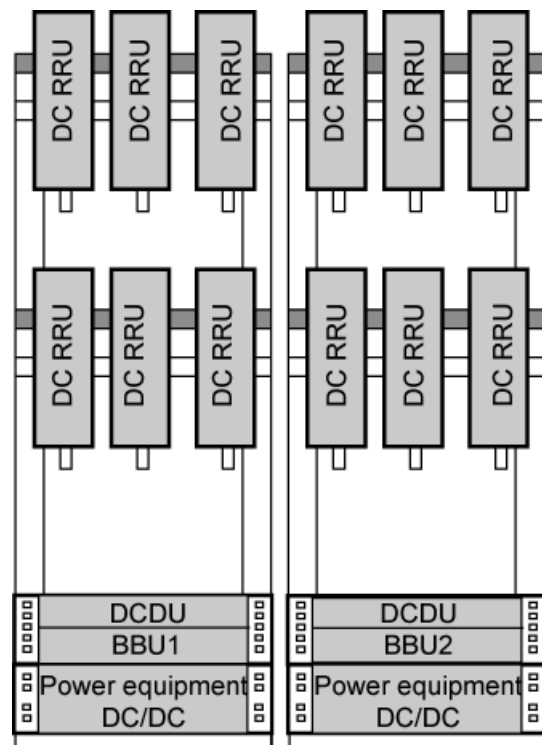
Figure 3-34 Height-unrestricted triple-mode scenario (+24 V DC)

SRS02C0003

Table 3-40 Installation of 12 RRUs (in GSM+UMTS+LTE mode)

Position	GU+LTE	GL+UMTS
ICR1	Six RRU3908s	Six RRU3908s
ICR2	Six RRU3201s	Six RRU3804s

Independent RRU installation scenario (IFS06+RRU)

In this scenario, three RRUs or six RRUs are installed. The configurations and installations of the RRUs in the IFS06+RRU scenario and in the IFS06+IMB03+RRU scenario are the same.

For details, see [RRU and IMB03 combination installation scenario \(IFS06+IMB03+RRU\)](#). [Figure 3-35](#) takes the installation of six RRUs as an example.

Figure 3-35 Installation of the DC RRUs on the IFS06

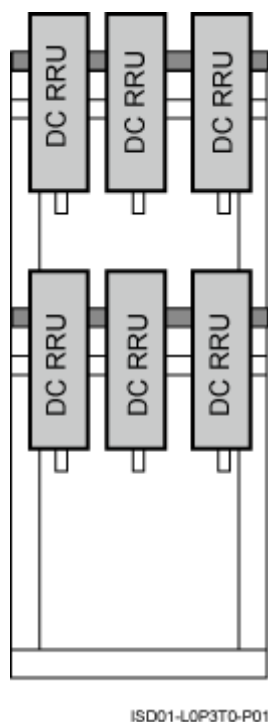

3.3 Dimensions and Installation Clearance Requirements

This section describes the dimensions and installation clearance requirements for the relevant devices.

Dimensions

[Figure 3-36](#) shows the dimensions of the IFS06.

Figure 3-36 Dimensions of the IFS06

Figure 3-37 shows the dimensions of the IMB03.

Figure 3-37 Dimensions of the IMB03

Recommended Clearance for the ICR (DC-RRU-Based)

Figure 3-38 shows the recommended clearance for installing the ICR where the DC RRU is installed.

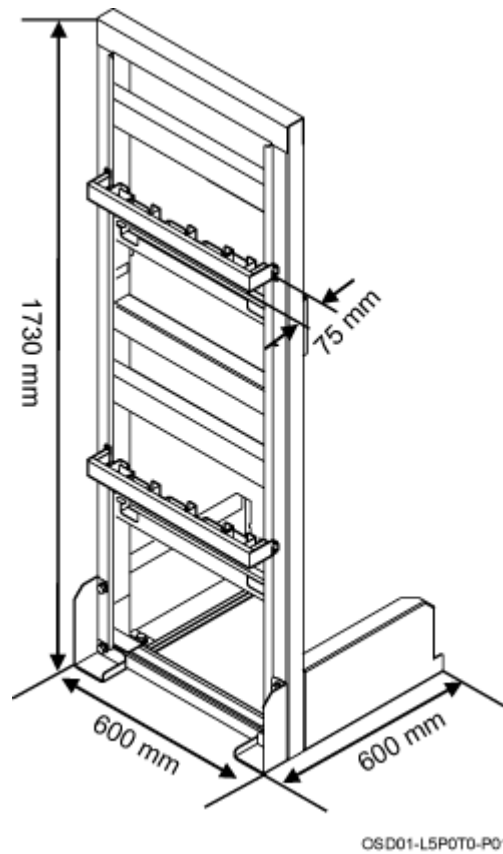
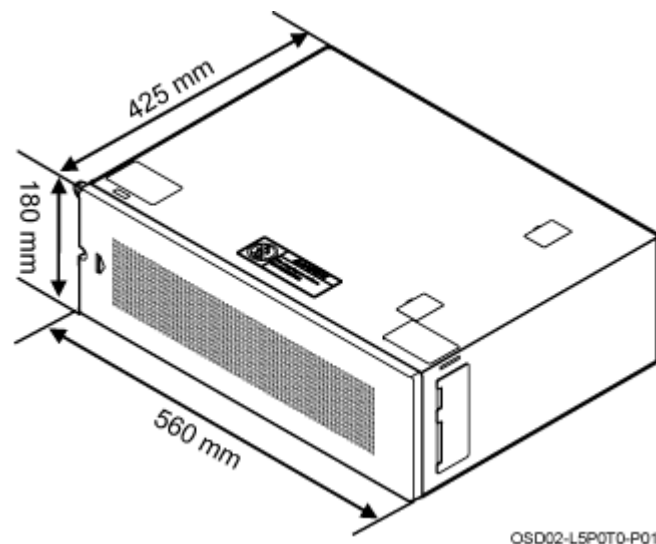
Figure 3-38 Recommended clearance for the ICR (DC-RRU-based)

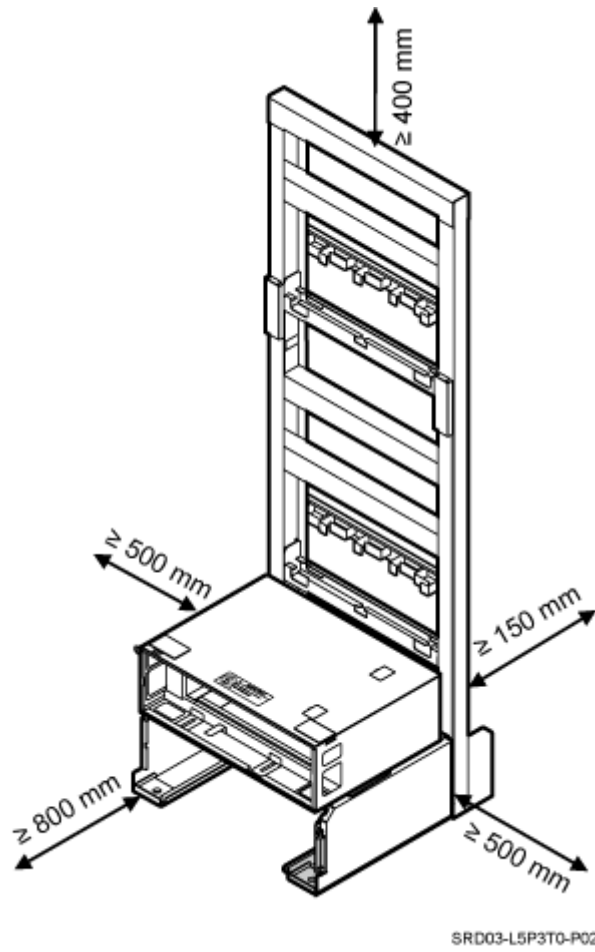

Recommended Clearance for the ICR (AC-RRU-Based)

Figure 3-39 shows the recommended clearance for installing the ICR where the AC RRU is installed.

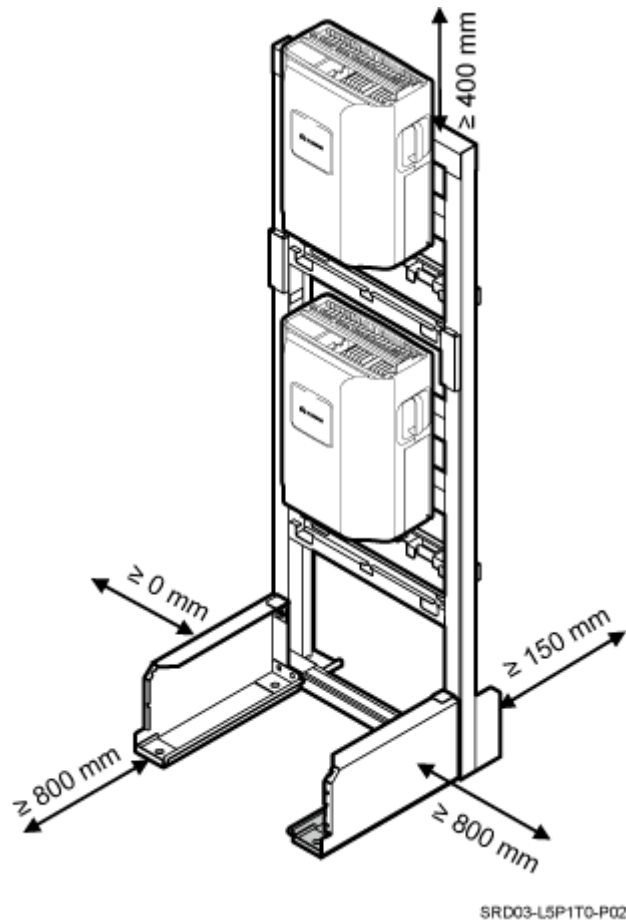
Figure 3-39 Recommended clearance for the ICR (AC-RRU-based)**NOTE**

When the recommended clearance is provided, the IFS06 where the AC RRU is installed can be installed with its left side against the wall.

Minimum Clearance for the ICR (DC-RRU-Based)

Figure 3-40 and **Figure 3-41** show the minimum clearance for installing the ICR where the DC RRU is installed.

Figure 3-40 Minimum clearance for the ICR in the height-unrestricted scenario

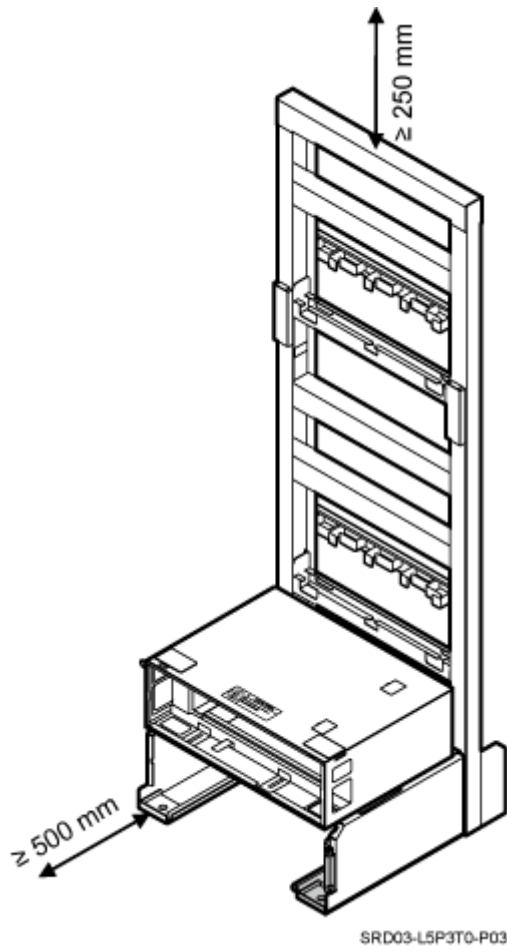
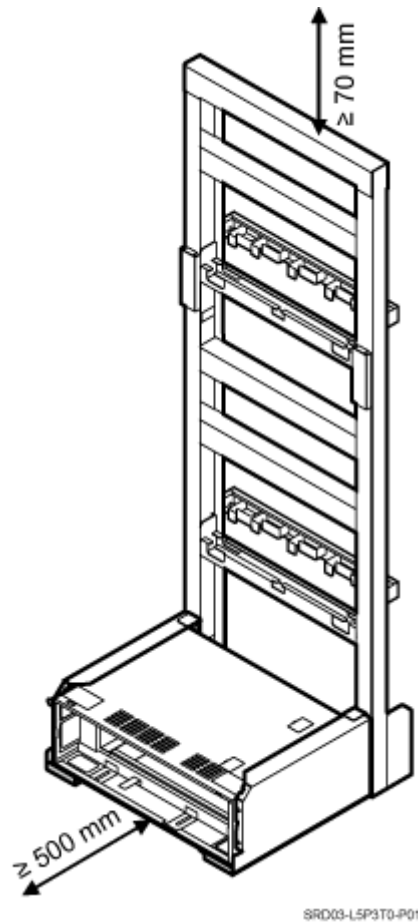

Figure 3-41 Minimum clearance for the ICR in the height-restricted scenario**NOTE**

When the minimum clearance is provided, the IFS06 where the DC RRU is installed can be installed with its back and both sides against the wall.

Minimum Clearance for the ICR (AC-RRU-Based)

Figure 3-42 shows the minimum clearance for the installing the ICR where the AC RRU is installed.

Figure 3-42 Minimum clearance for the ICR (AC-RRU-based)

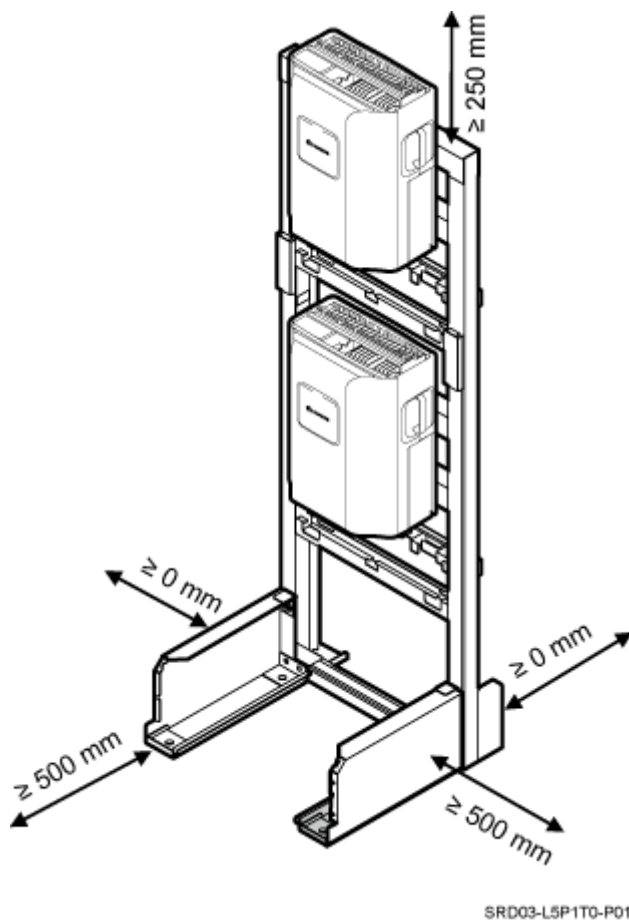

NOTE

When the minimum clearance is provided, the IFS06 where the AC RRU is installed can be installed with its back and left side against the wall.

Clearance Requirements for Combined Cabinets

Figure 3-43 shows the clearance requirements for combined cabinets.

Figure 3-43 Clearance requirements for combined cabinets

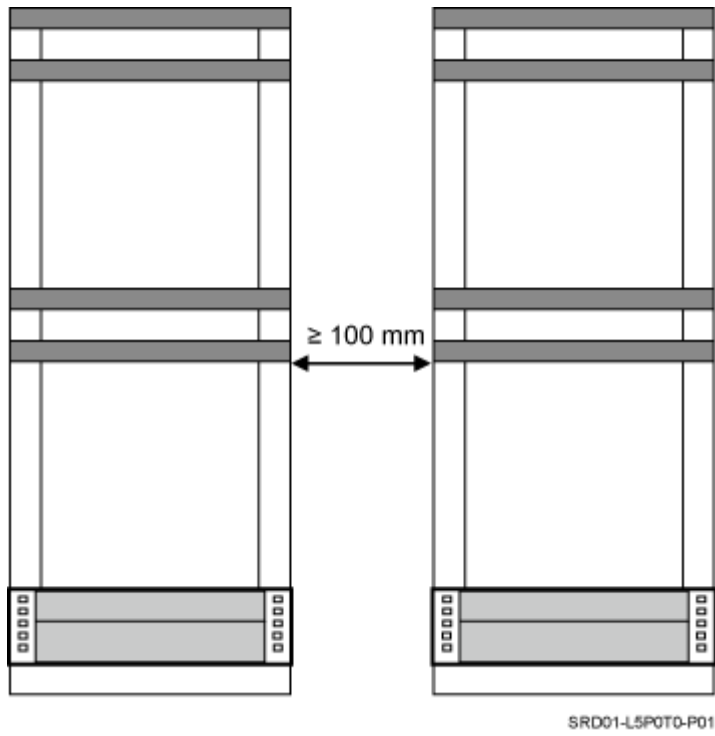

4 Unpacking the Equipment

Unpack and check the delivered equipment to ensure that all the materials are included and intact.

Context

 **NOTE**

When transporting, moving, or installing the equipment, components, or parts, you must:

- Prevent them from colliding with doors, walls, shelves, or other objects.
- Wear clean gloves, and avoid touching the equipment, components, or parts with bare hands, sweat-soaked gloves, or dirty gloves.

Procedure

Step 1 Check the total number of articles in each case according to the packing list.

If ...	Then ...
The total number tallies with the packing list	Go to Step 2 .
The total number does not tally with the packing list	Find out the cause and report any missing articles to the local Huawei office.

Step 2 Check the exterior of the packing case.

If ...	Then ...
The outer packing is intact	Go to Step 3 .
The outer packing is severely damaged or soaked	Find out the cause and report it to the local Huawei office.

Step 3 Check the type and quantity of the equipment in the cases according to the packing list.

If ...	Then ...
Types and quantity of the article tally with those on the packing list	Sign the <i>Packing List</i> with the customer.
There is any shipment shortage or wrong shipment	Fill in and submit the <i>Cargo Shortage and Mishandling Report</i> .
Articles are damaged.	Fill in and submit the <i>Article Replacement Report</i> .

**WARNING**

To protect the equipment and prevent damage to the equipment, you are advised to keep the unpacked equipment and packing materials indoors, take photos of the stocking environment, packing case or carton, packing materials, and any rusted or eroded equipment, and then file the photos.

---End

5 Obtaining the ESN

The Electronic Serial Number (ESN) is a unique identifier of a Network Element (NE). Record the ESN for later commissioning of the base station before installation.

Procedure

Step 1 Record the ESN on the BBU.

- If there is not a label on the FAN unit of the BBU, you must record the ESN and site information that is printed on a mounting ear of the BBU. **Figure 5-1** shows the position of the ESN.
- If there is a label on the FAN unit of the BBU, the ESN is printed on the label and a mounting ear of the BBU. In this case, you must take the label and record the site information on the side labeled Site, as shown in **Figure 5-2**.

Figure 5-1 Obtaining the ESN (1)

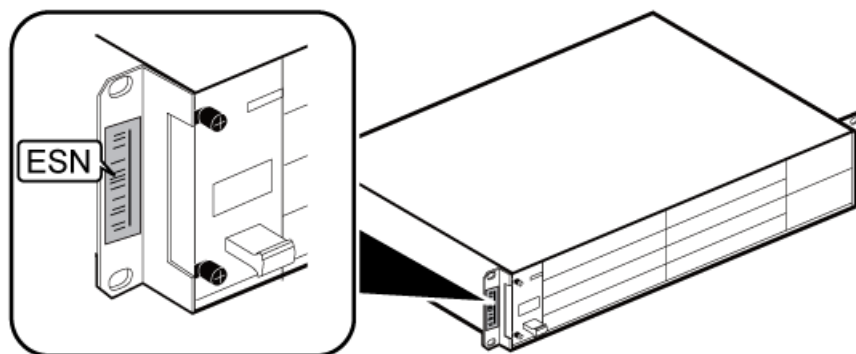
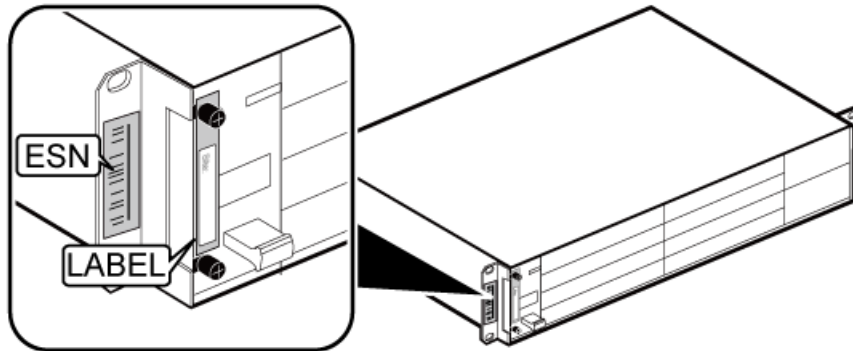

Figure 5-2 Obtaining the ESN (2)

Step 2 Report the ESN to the engineer for the commissioning of the base station.

---End

6 Installation Process

This section describes the process of installing the DBS39000 on the ICR.

Figure 6-1 shows the installation process.

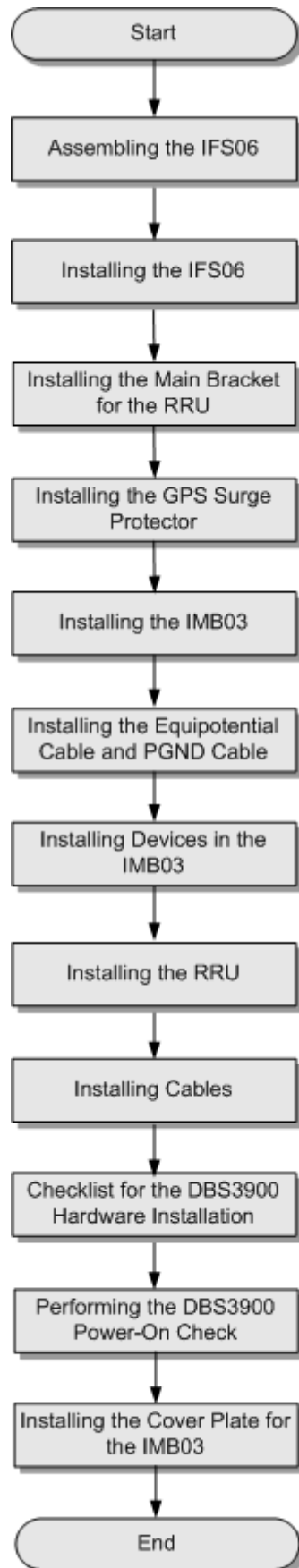
Figure 6-1 Installation process

DID03-LOP010-L01

7 Assembling the IFS06

This chapter describes the procedure for assembling the IFS06.

Procedure

- Step 1** Use four M12x30 bolt assemblies to secure the rear feet to the main frame, as shown in [Figure 7-1](#).

 **NOTE**

Place the foam pad or cardboard under the IFS06 to prevent any damage to the paint.

Figure 7-1 Installing the rear feet

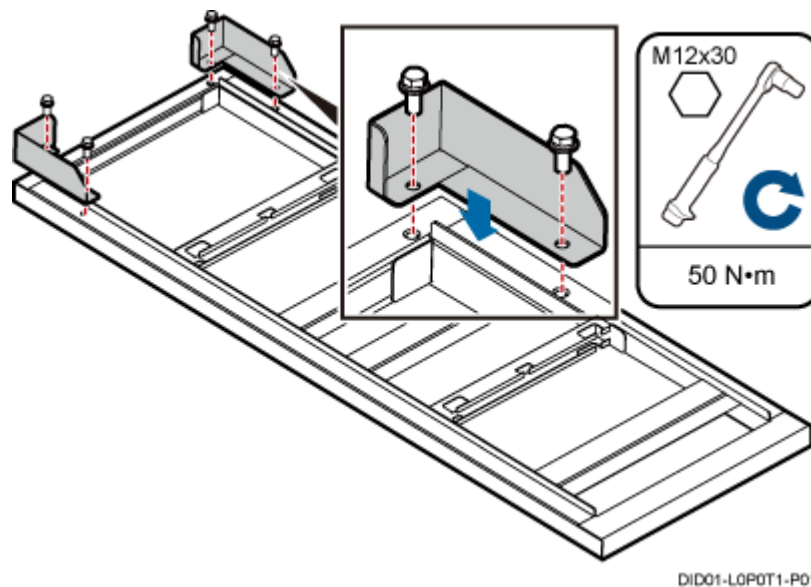

- Step 2** Rotate the IFS06 by 180°, and then use six M12x30 bolt assemblies to secure the front feet to the main frame, as shown in [Figure 7-2](#).

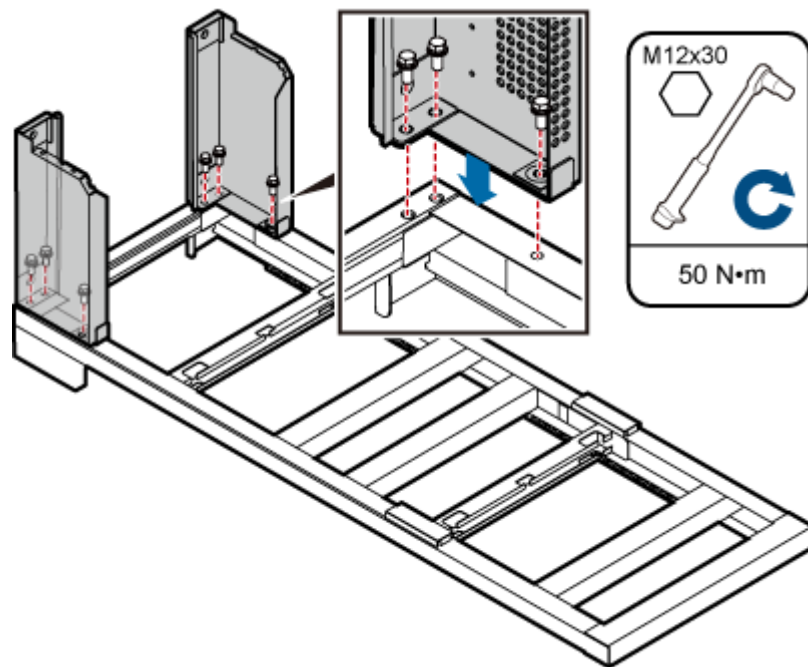
Figure 7-2 Installing the front feet

D1D01-LGP0T1-P02

Step 3 Move down the adjustable beam from the 2 m high position to the 1.8 m high position, as shown in [Figure 7-3](#).

NOTE

In the height-restricted scenario, move the adjustable beam to the 1.8 m high position. In the height-unrestricted scenario, skip the step.

Figure 7-3 Moving down the adjustable beam

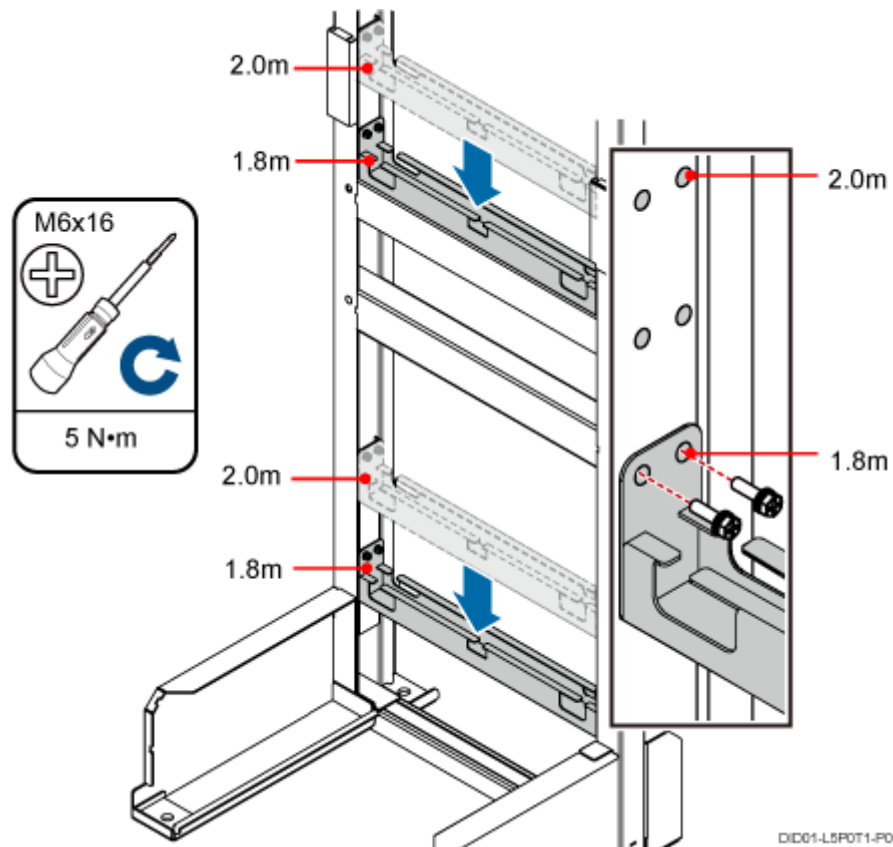

Step 4 Fit the tabs of the cable rack into the corresponding slots on the columns of the IFS06, as shown in [Figure 7-4](#).

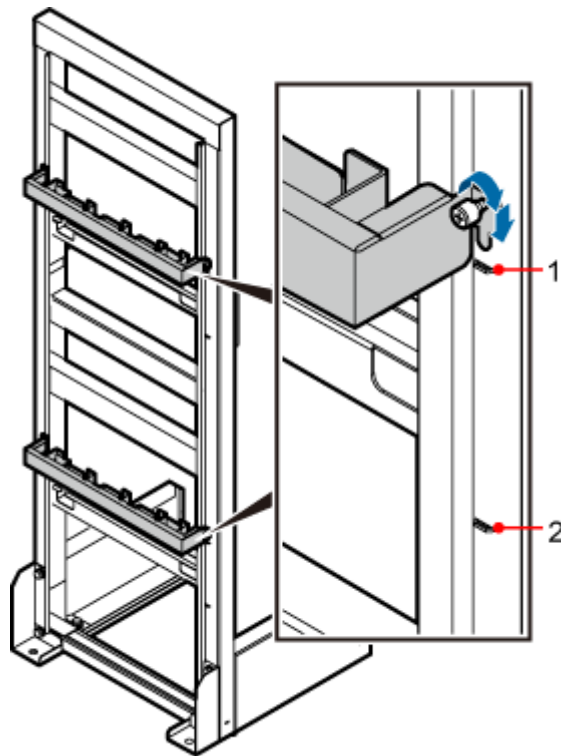
Figure 7-4 Installing the cable rack

DID01-L1P0T0-P01

(1) Slot for installing the cable rack in the height-unrestricted scenario

(2) Slot for installing the cable rack in the height-restricted scenario

 **NOTE**

In the height-unrestricted scenario, fit the tabs of the cable rack into the slots for the height-unrestricted scenario. In the height-restricted scenario, fit the tabs of the cable rack into the slots for the height-restricted scenario.

Step 5 Install the adapting piece for the GPS surge protector to the upper adjustable beam, as shown in [Figure 7-5](#).

Figure 7-5 Installing the adapting piece for the GPS surge protector

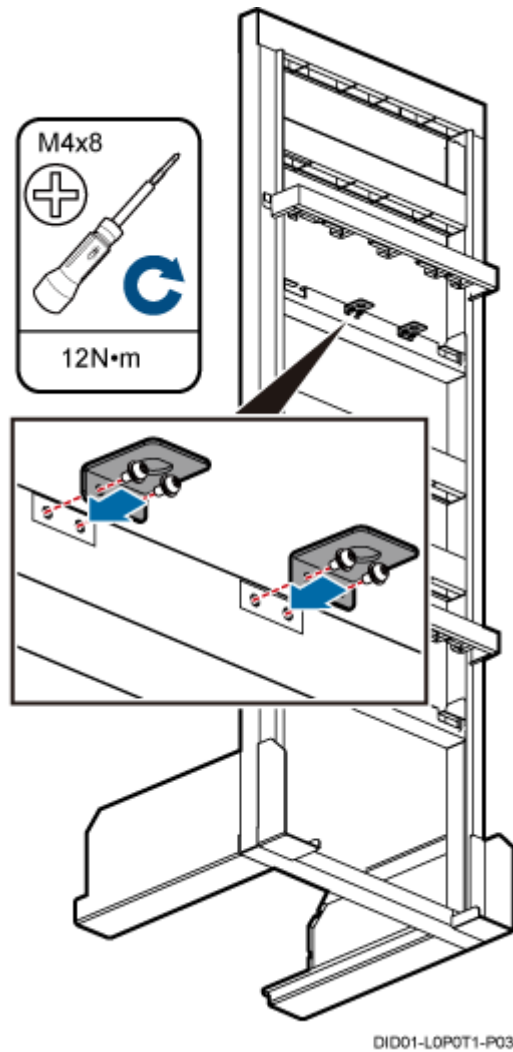

---End

8 Installing the IFS06

About This Chapter

This chapter describes the procedure for installing the IFS06 on the concrete floor and ESD floor.

[8.1 Installing the IFS06 on the Concrete Floor](#)

This section describes the procedure for installing the IFS06 on the concrete floor.

[8.2 Installing the IFS06 on the ESD Floor](#)

This section describes the procedure for installing the IFS06 on the ESD floor.

8.1 Installing the IFS06 on the Concrete Floor

This section describes the procedure for installing the IFS06 on the concrete floor.

Procedure

- Step 1** Place the marking template on the horizontal floor, and then use a marker to mark four anchor points, as shown in [Figure 8-1](#).

Figure 8-1 Marking anchor points

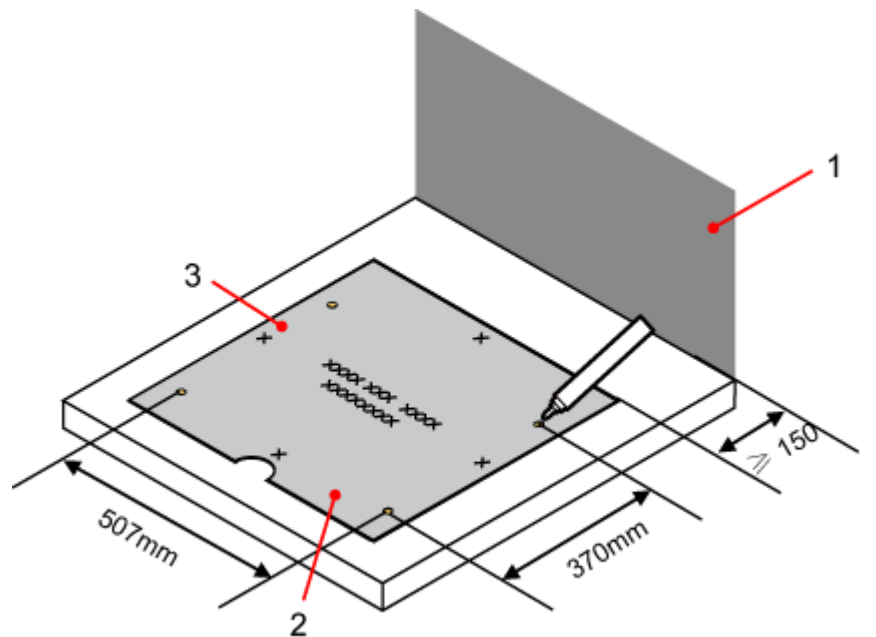

DID01-LSP0T0-B01

(1) Wall

(2) Front

(3) Left

- Step 2** Drill holes at the anchor points and install the expansion bolt assemblies.

1. Use a hammer drill with bit 16 to drill holes at the marked anchor points. Ensure that the depth of each hole ranges from 52 mm to 60 mm, as shown in [Figure 8-2](#).

Use a vacuum cleaner to clear the dust inside and around the holes. If the inter-hole spacing is too wide or too narrow, locate and drill holes again.

Figure 8-2 Drilling holes

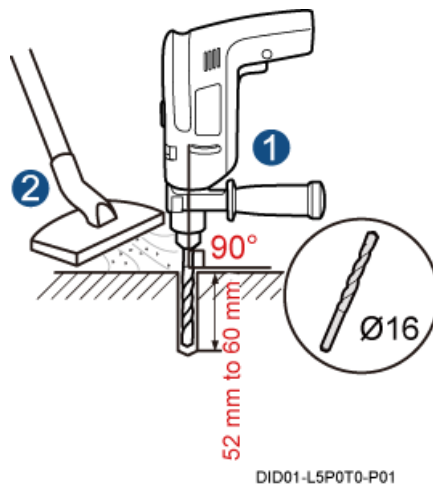

CAUTION

Take proper safety measures before drilling holes to protect your eyes and respiratory tract against the dust.

2. Assemble the expansion bolt assembly by referring to [Figure 8-3](#), slightly tighten the expansion bolt, and then insert it into the hole vertically.

Figure 8-3 Assembling an expansion bolt

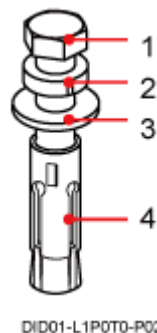

(1) M12x60 bolt (2) Spring washer 12 (3) Flat washer 12 (4) Expansion tube

3. Use a rubber mallet to hammer the expansion bolt until the expansion tube is buried into the hole, and then use a torque wrench to tighten the M12x60 bolt until the tightening torque reaches 45 N·m, as shown in [Figure 8-4](#).

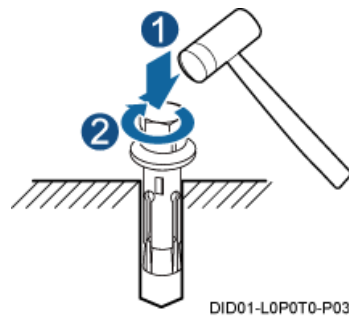
Figure 8-4 Installing an expansion bolt

4. Remove the M12x60 bolt, spring washer, and flat washer from each expansion bolt assembly in sequence, as shown in **Figure 8-5**.

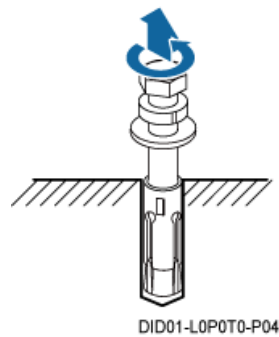
Figure 8-5 Removing a bolt

Step 3 Install the bolts in the corresponding mounting holes on the IFS06, as shown in **Figure 8-6**.

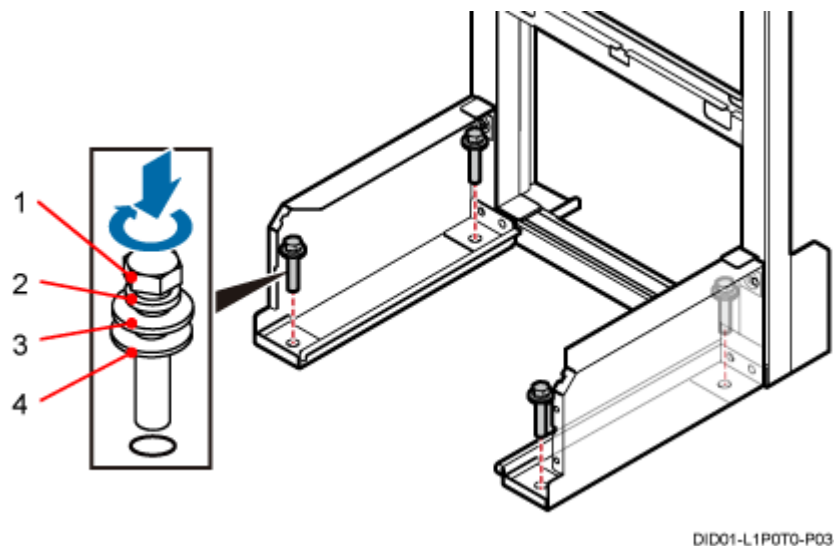
Figure 8-6 Installing the bolts

- (1) M12x60 bolt (2) Spring washer (3) Flat washer (4) Insulation washer

1. Place the IFS06 in the position for installation, and then align the mounting holes on the IFS06 with the anchor points on the floor.

2. Lead each bolt through the spring washer, flat washer, and insulation washer in sequence, and then install the bolt in the mounting hole on the IFS06.
 3. Install the bolt into the expansion tube.
- Step 4** Use a level to check whether the feet of the IFS06 are on a horizontal plane. If not, add adjusting pads to ensure that the feet of the IFS06 are on a horizontal plane.
1. Pre-tighten the bolts, as shown in **Figure 8-7**.

Figure 8-7 Pre-tightening the bolts

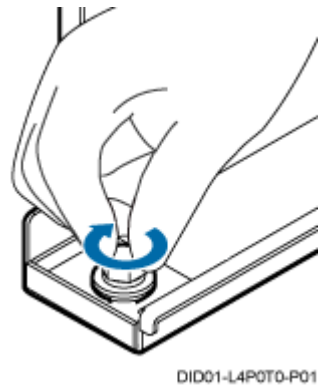

2. Use a level to check whether the feet and bottom beam of the IFS06 are on a horizontal plane, as shown in **Figure 8-8**.

Figure 8-8 Checking and adjusting the level of the IFS06

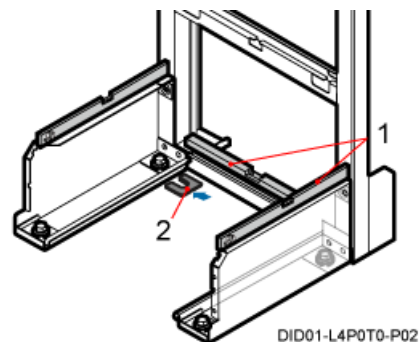

(1) Level

(2) Adjusting pad

3. Add adjusting pads to ensure that the feet and bottom beam of the IFS06 are on a horizontal plane, as shown in **Figure 8-8**.

NOTE

The adjusting pads must be added at the expansion bolt assemblies.

4. Tightening the bolts using a socket wrench, as shown in **Figure 8-9**.

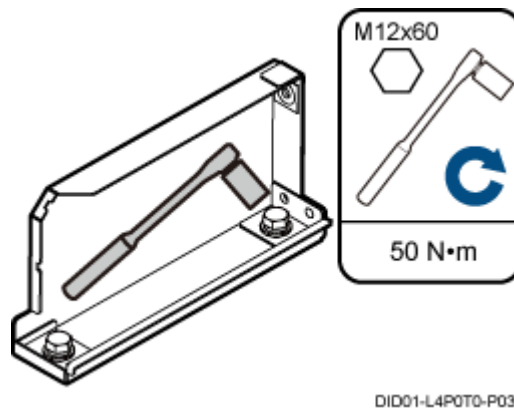
Figure 8-9 Tightening the bolts

---End

8.2 Installing the IFS06 on the ESD Floor

This section describes the procedure for installing the IFS06 on the ESD floor.

Context

Figure 8-10 shows the support for installing the ESD floor, which is classified into support with adjustable height (I) and support with fixed height (II). The installation process of two supports is the same, and the following descriptions are based on the support with adjustable height (I).

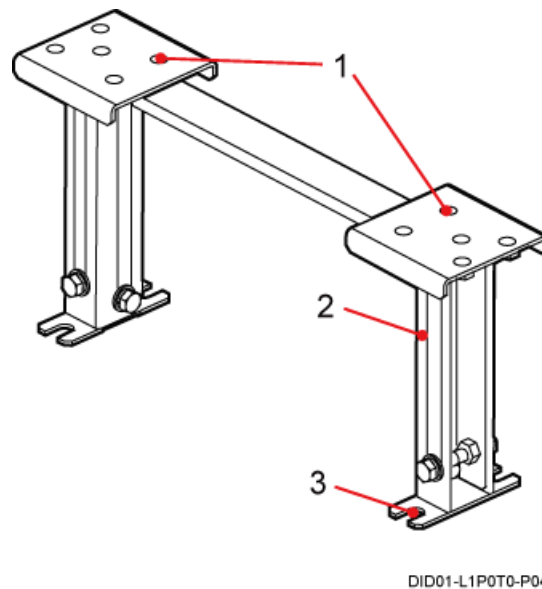
Figure 8-10 Support for installing the ESD floor

(1) Mounting holes for the ESD floor (2) Support (3) Mounting hole for the concrete floor

The height of an ESD floor refers to the spacing between the concrete floor and the upper surface of the ESD floor.

Type	Height of the ESD Floor
I	296 mm to 495 mm
II	At least 120 mm, depending on the actual floor height

Procedure

- Step 1** Place the marking template on the ESD floor, and then use a marker to mark four anchor points, as shown in [Figure 8-11](#).

Figure 8-11 Marking anchor points

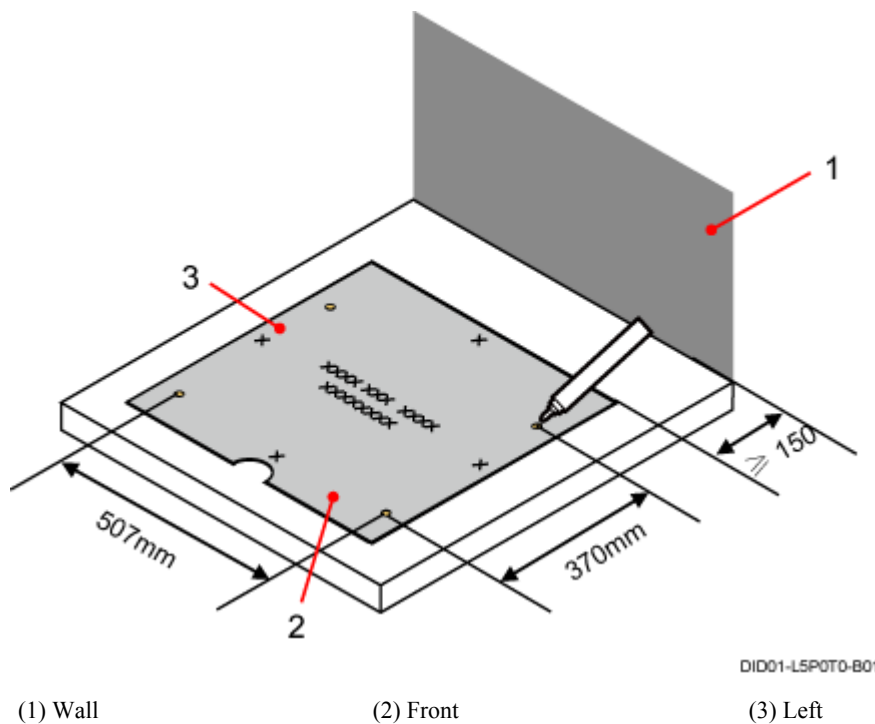

- Step 2** Drill holes on the ESD floor, as shown in [Figure 8-12](#). Ensure that the hammer drill penetrates the ESD floor.

Use a vacuum cleaner to clear the dust inside and around the holes. If the inter-hole spacing is too wide or too narrow, locate and drill holes again.

Figure 8-12 Drilling holes

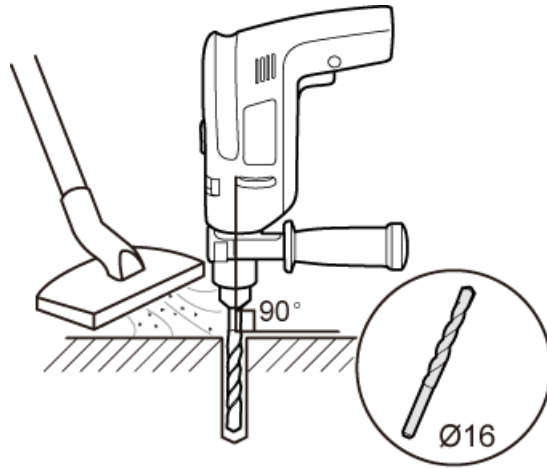

DID01-L0P0T0-B01



CAUTION

Take proper safety measures before drilling holes to protect your eyes and respiratory tract against the dust.

Step 3 Install the support for installing the ESD floor, as shown in [Figure 8-13](#).

Figure 8-13 Installing the support

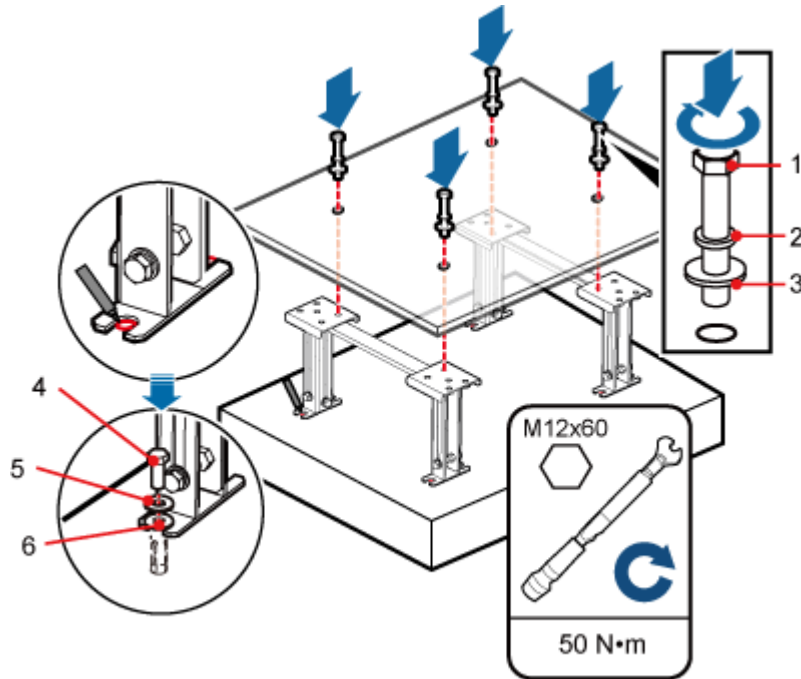

DID01-L1P0T1-P01

- (1) M12x70 bolt
- (2, 5) Spring washer 12
- (3,6) Flat washer 12
- (4) M12x60 bolt

1. Mark the positions of the mounting hole for the concrete floor on the concrete floor, drill holes in the positions, and then install the expansion bolt assemblies.
2. Place the support under the ESD floor, and then use M12x70 bolts to temporarily secure the support.

 **NOTE**

The height locking bolts are delivered with the support for installing the ESD floor.

When tightening the height locking bolts, you should tighten the bolts in the middle before tightening the bolts on both sides.

- Step 4** Remove the bolts that you use in **Step 3** to temporarily secure the support for installing the ESD floor, as shown in **Figure 8-14**.

Figure 8-14 Removing the bolts

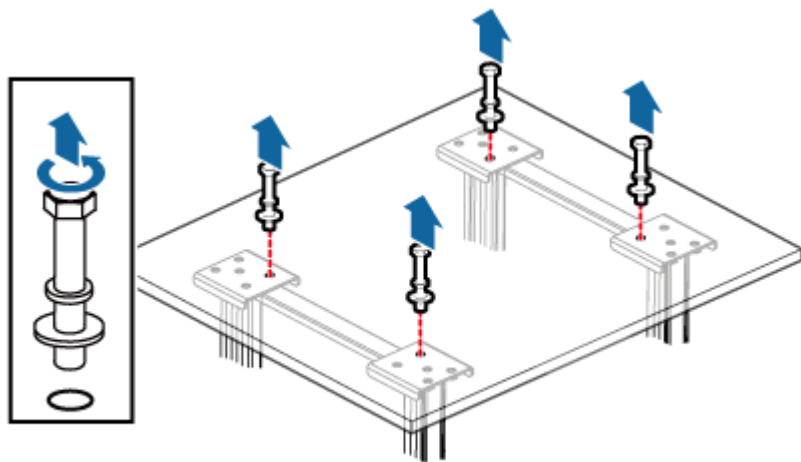

DID01-L0P0T0-P05

- Step 5** Install the IFS06 on the ESD Floor, as shown in **Figure 8-15**.

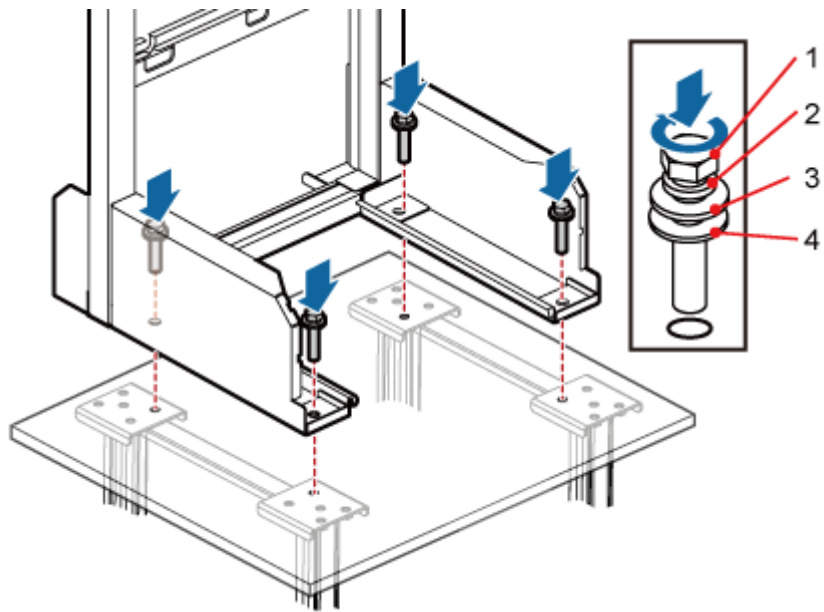
Figure 8-15 Install the IFS06.

DID01-L1P0T0-P05

- (1) M12x70 bolt (2) Spring washer (3) Flat washer (4) Insulating washer

Step 6 Use a level to check whether the feet of the ICR are on a horizontal plane. If not, add adjusting pads to ensure that the feet of the ICR are on a horizontal plane.

1. Pre-tighten the bolts, as shown in [Figure 8-16](#).

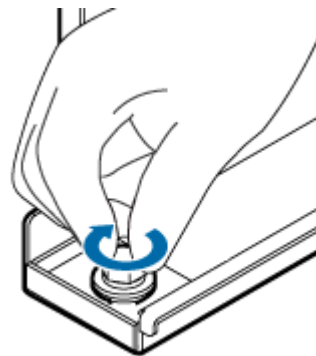
Figure 8-16 Pre-tightening the bolts

DID01-L4P0T0-P01

2. Use a level to check whether the feet and bottom beam of the ICR are on a horizontal plane, as shown in [Figure 8-17](#).

Figure 8-17 Checking and adjusting the level of the ICR

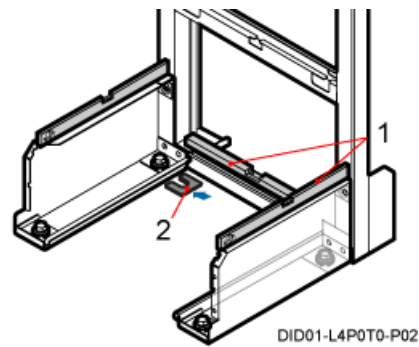

(1) Level

(2) Adjusting pad

3. Add adjusting pads to ensure that the feet and bottom beam of the ICR are on a horizontal plane, as shown in [Figure 8-17](#).

 **NOTE**

The adjusting pads should be added at the expansion bolt assemblies.

4. Tightening the bolts using a socket wrench, as shown in [Figure 8-18](#).

Figure 8-18 Tightening the bolts

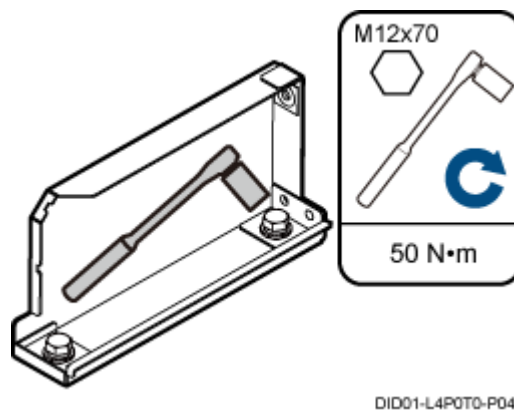

---End

9 Installing the Main Bracket for the RRU

About This Chapter

This chapter describes the procedure for installing the main bracket for the DC RRU and AC RRU.

Context

Figure 9-1 shows the main and auxiliary brackets for the RRU.

Figure 9-1 Main and auxiliary brackets for the RRU

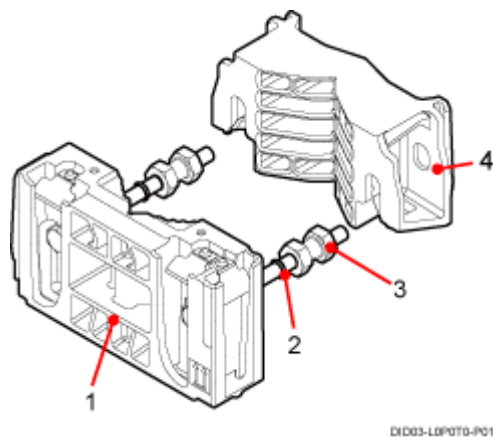

- (1) Main bracket (2) Rubber washer (3) Dual-nut bolt (4) Auxiliary bracket

NOTE

If the RRU needs to be installed on the IFS06, only the main bracket is required.

9.1 Installing the Main Bracket for the DC RRU

This section describes the procedure for installing the main bracket for the DC RRU.

Context

NOTE

- Install RRUs in the sequence from bottom to top and from left to right.
- The contact pieces on the main bracket are locked before RRUs are installed.
- Rubber washers are easily pressed or broken.
- If the installation clearance is limited, the RRU must be first installed on the side where there is the least space.

Procedure

- Height-unrestricted scenario

Install the main bracket in the height-unrestricted scenario, as shown in [Figure 9-2](#). For details about how to install the main bracket, see the labels on the IFS06.

Figure 9-2 Installing the main bracket in the height-unrestricted scenario

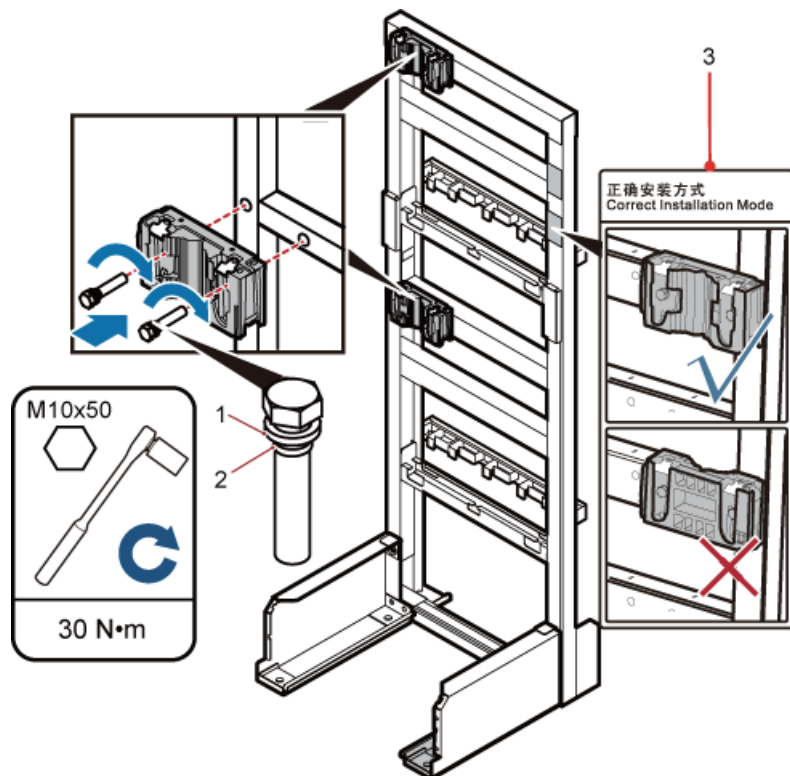

DID03-L1P3T1-P02

(1) Spring washer

(2) Rubber washer

(3) Label

- Height-restricted scenario

Install the main bracket in the height-restricted scenario, as shown in [Figure 9-3](#). For details about how to install the main bracket, see the labels on the IFS06.

 **NOTE**

Before installing the main bracket in the height-restricted scenario, you must use a finger to push the rubber cap out.

Figure 9-3 Installing the main bracket in the height-restricted scenario

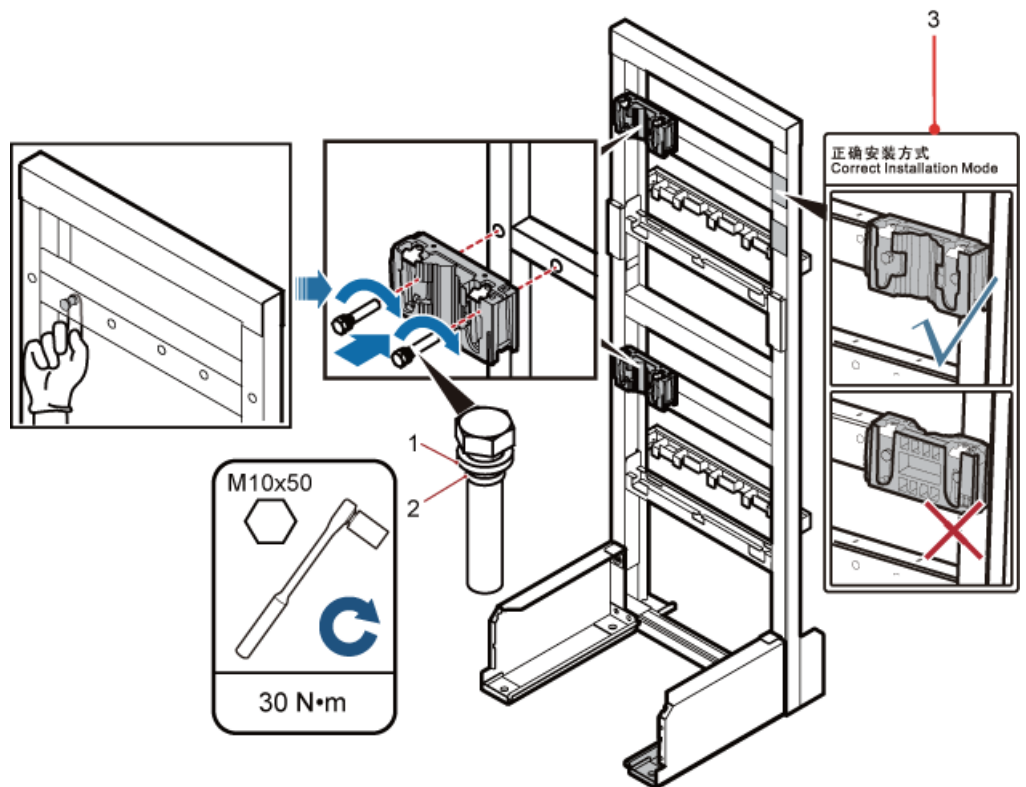

DID03-L1P3T1-P01

(1) Spring washer

(2) Rubber washer

(3) Label

---End

9.2 Installing the Main Bracket for the AC RRU

This section describes the procedure for installing the main bracket for the AC RRU.

Context

 **NOTE**

- Install RRUs in the sequence from bottom to top and from left to right.
- The contact pieces on the main bracket are locked before RRUs are installed.
- Rubber washers are easily pressed or broken.
- If the installation clearance is limited, the RRU must be first installed on the side where there is the least space.

Procedure

- Height-unrestricted scenario

Install the main bracket in the middle of the bean 1 and the bean 2 respectively in the height-unrestricted scenario, as shown in **Figure 9-4**. For details about how to install the main bracket, see the labels on the IFS06.

Figure 9-4 Installing the main bracket in the height-unrestricted scenario

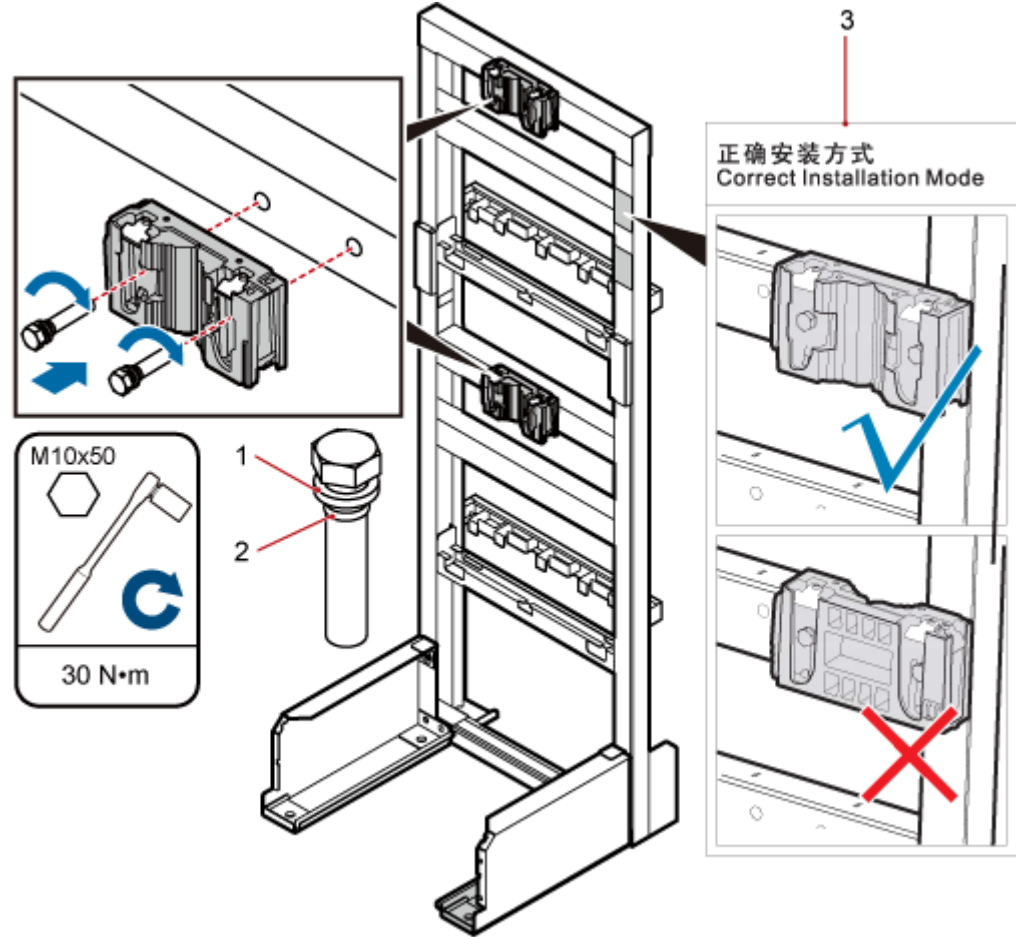

DID03-L0P1T0-P01

- (1) Spring washer
- (2) Rubber washer
- (3) Label

- Height-restricted scenario

Install the main bracket in the middle of the bean 1 and the bean 2 in the height-restricted scenario, as shown in **Figure 9-5**. For details about how to install the main bracket, see the labels on the IFS06.

Figure 9-5 Installing the main bracket in the height-restricted scenario

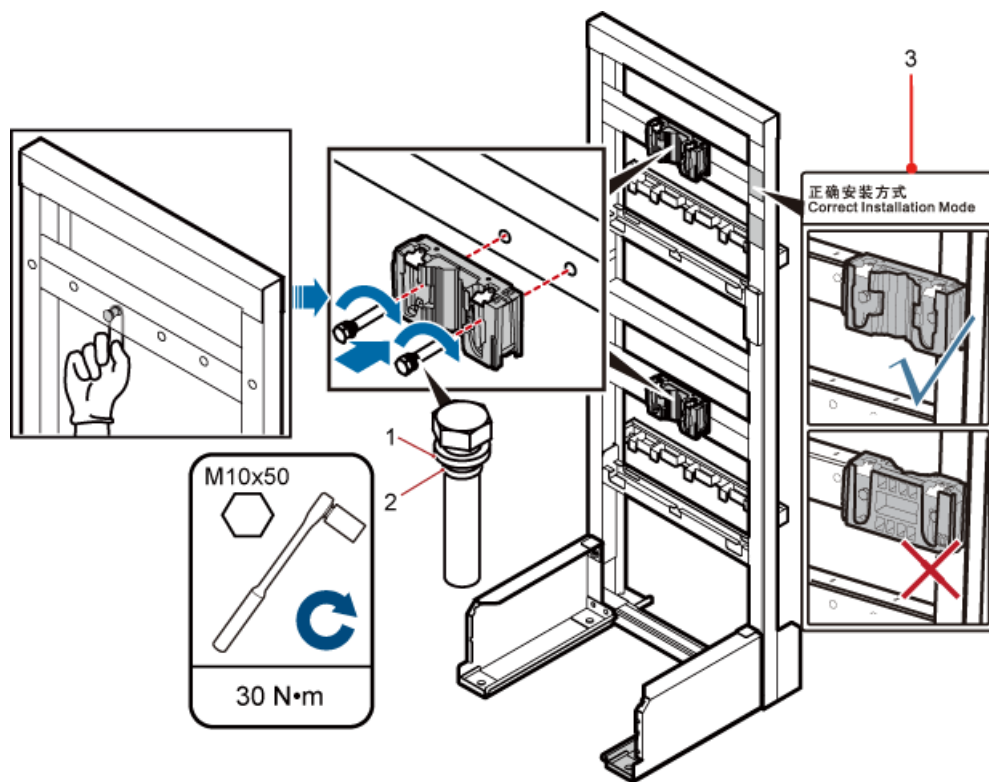

(1) Spring washer

(2) Rubber washer

(3) Label

---End

DID03-L0P1T0-P03

10 Installing the GPS Surge Protector

This chapter describes the procedure for installing the GPS surge protector.

Context

Two types of GPS surge protector can be installed on the IFS06, as shown in [Figure 10-1](#).

Figure 10-1 GPS surge protector

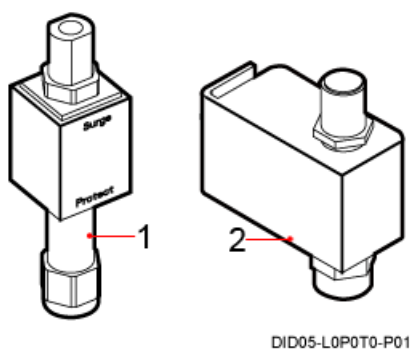

(1) GPS surge protector A

(2) GPS surge protector B

NOTE

The IFS06 can be installed with one or two GPS surge protector, which should be decided according to the actual scenario.

GPS surge protector does not need a PGND cable.

Procedure

- Step 1** Remove the insert nut and toothed washer from the connector of the GPS clock signal cable, as shown in [Figure 10-2](#).

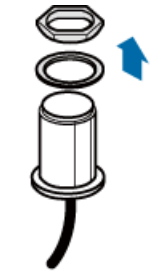
Figure 10-2 Removing the insert nut and toothed washer

DID05-L0P0T0-P02

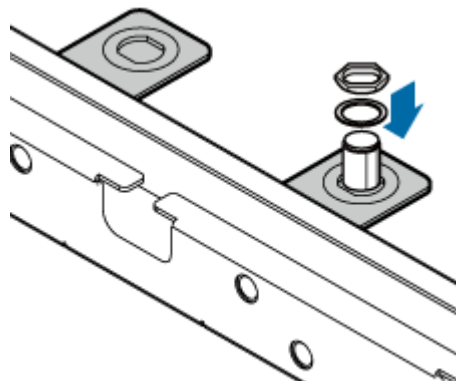
Step 2 Fix the connector to the adapting piece, as shown in **Figure 10-3**.**Figure 10-3** Installing the connector

DID05-L0P0T0-P03

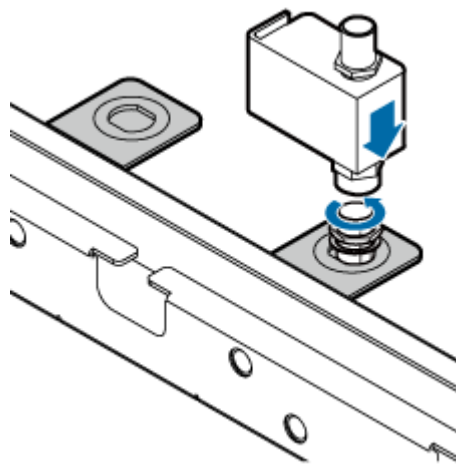
Step 3 Install the GPS surge protector on the connector, as shown in **Figure 10-4**.**Figure 10-4** Installing the GPS surge protector

DID05-L0P0T0-P04

NOTE

When installing the GPS surge protector, pre-tighten it with hands, and then use a wrench to tighten it.

Step 4 Install the PGND cable for the GPS surge protector, as shown in **Figure 10-5**.

Figure 10-5 Installing the PGND cable for the GPS surge protector

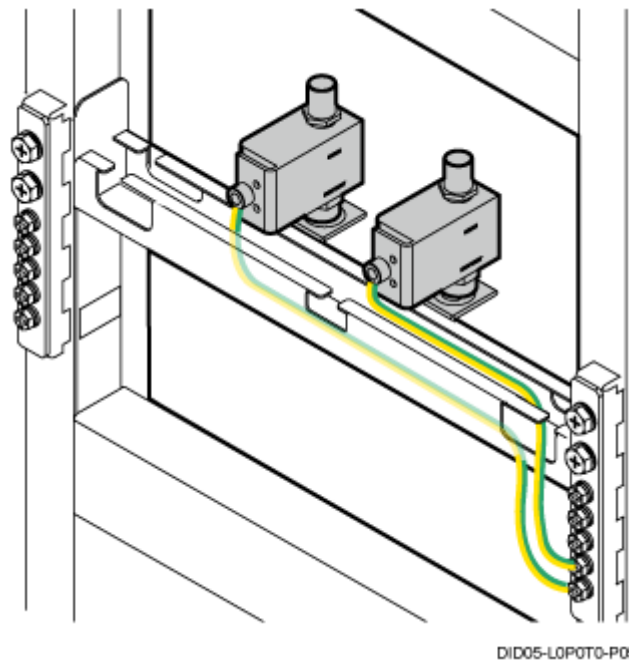

Step 5 Route cables by referring to [15.1 Cabling Requirements](#).

Step 6 Use cable ties to bind cables.

Step 7 Label the installed cables by referring to Attaching a Sign Plate Label.

----End

11 Installing the IMB03

About This Chapter

This chapter describes the procedure for installing the IMB03.

[11.1 Installing the IMB03 on the Upper Level Separately](#)

This section describes the procedure for installing the IMB03 on the upper level separately.

[11.2 Installing the IMB03 on the Lower Level Separately](#)

This section describes the procedure for installing the IMB03 on the lower level separately.

[11.3 Installing the IMB03s on the Upper and Lower Levels](#)

This section describes the procedure for installing the IMB03s on the upper and lower levels.

11.1 Installing the IMB03 on the Upper Level Separately

This section describes the procedure for installing the IMB03 on the upper level separately.

Context

 **NOTE**

In this scenario, only the IMB03 on the upper level needs to be installed.

Procedure

- Step 1** Remove the two protection plates from the top of the IMB03, as shown in [Figure 11-1](#).

Figure 11-1 Removing the protection plates

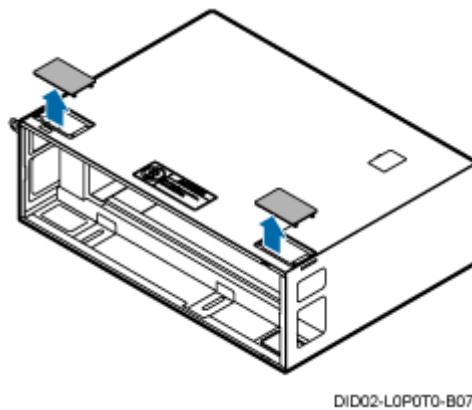

 **NOTE**

After all the cables are routed, cut parts of the protection plates and use the cut parts to seal the cable holes if there is spare space in the cable holes.

- Step 2** Install mounting ears horizontally on the IMB03, as shown in [Figure 11-2](#).

Figure 11-2 Installing mounting ears horizontally

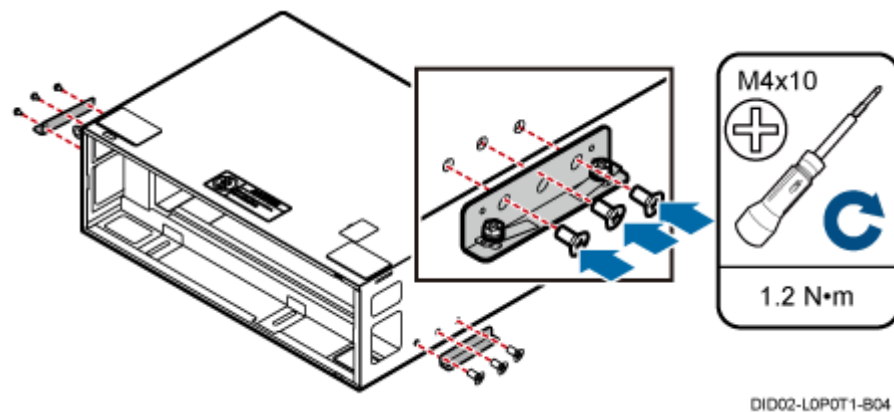

- Step 3** Secure the IMB03 to the feet of the ICR, as shown in [Figure 11-3](#).

Figure 11-3 Securing the IMB03 to the feet of the ICR

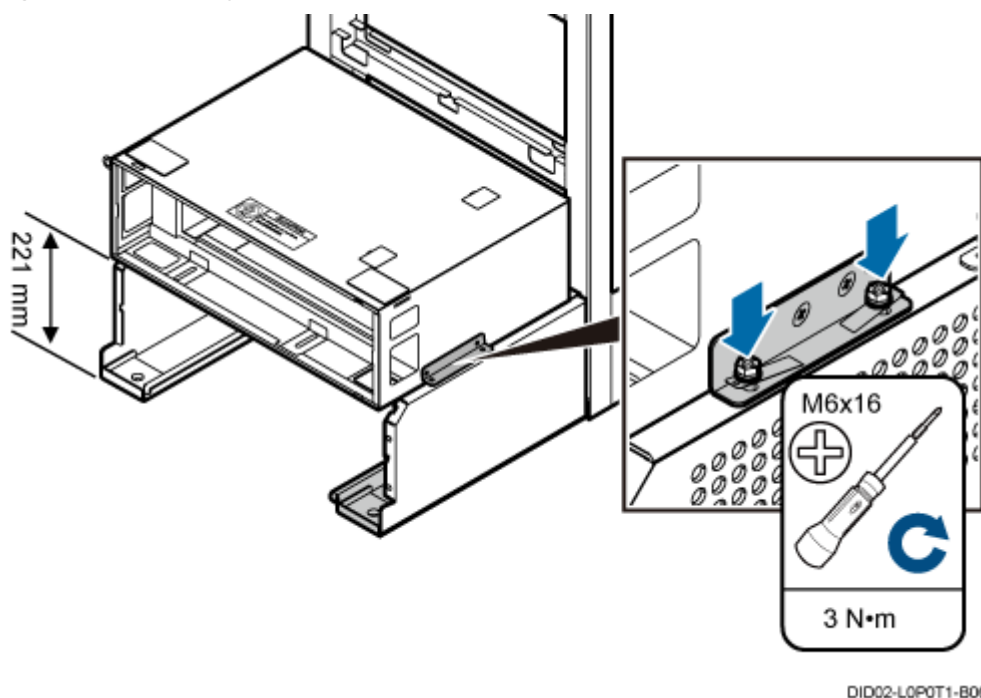

---End

11.2 Installing the IMB03 on the Lower Level Separately

This section describes the procedure for installing the IMB03 on the lower level separately.

Context

 **NOTE**

In this scenario, only the IMB03 on the lower level needs to be installed.

Procedure

Step 1 Remove the two protection plates from both sides of the IMB03, as shown in [Figure 11-4](#).

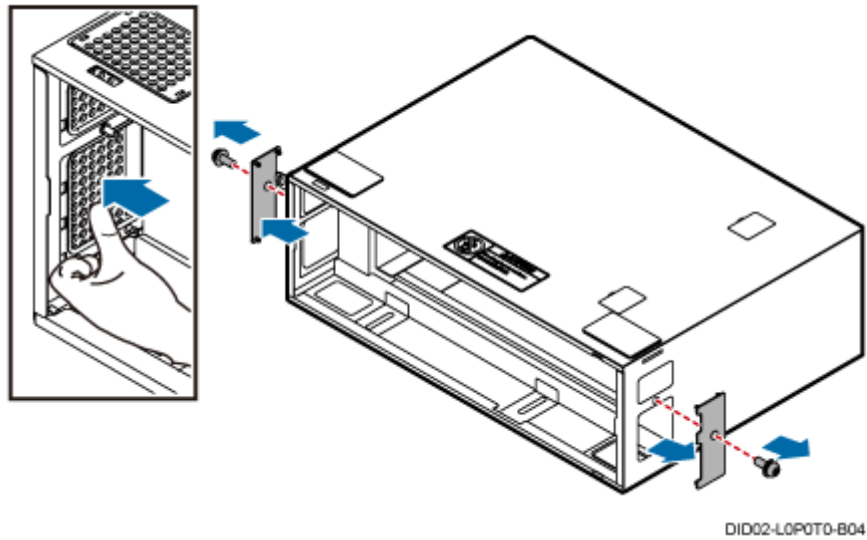
Figure 11-4 Removing the protection plates**NOTE**

After all the cables are routed, cut parts of the protection plates and use the cut parts to seal the cable holes if there is spare space in the cable holes.

Step 2 Install mounting ears vertically on the IMB03, as shown in [Figure 11-5](#).

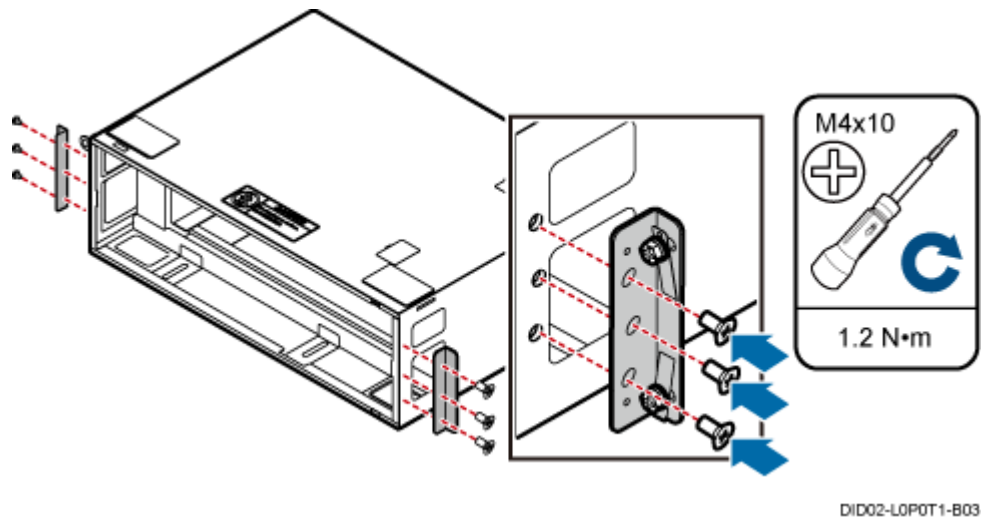
Figure 11-5 Installing mounting ears vertically

Step 3 Secure the IMB03 on the feet of the ICR, as shown in [Figure 11-6](#).

Figure 11-6 Securing the IMB03 on the feet of the ICR

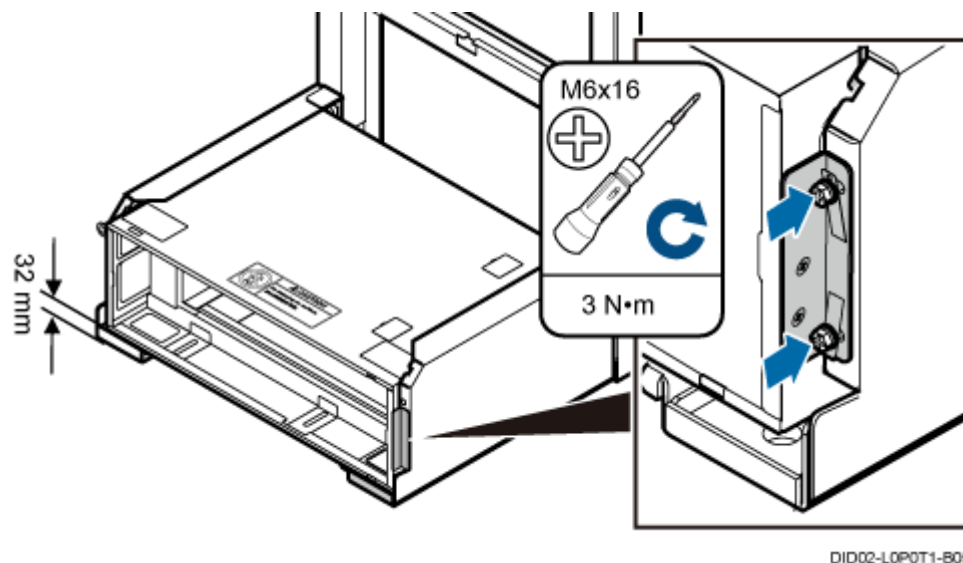

---End

11.3 Installing the IMB03s on the Upper and Lower Levels

This section describes the procedure for installing the IMB03s on the upper and lower levels.

Context

 **NOTE**

If two IMB03s are required, install an IMB03 on the lower level, and then install the other IMB03 on the upper level.

Procedure

- Step 1** Remove the four protection plates from the lower-level IMB03, as shown in [Figure 11-7](#).

Figure 11-7 Removing the protection plates from the lower-level IMB03

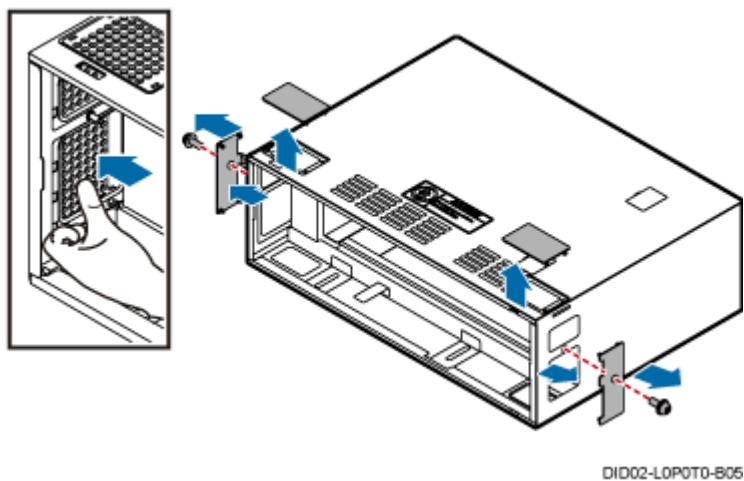

NOTE

After all the cables are routed, cut parts of the protection plates and use the cut parts to seal the cable holes if there is spare space in the cable holes.

Step 2 Install mounting ears vertically on the IMB03, as shown in [Figure 11-8](#).

Figure 11-8 Installing mounting ears vertically

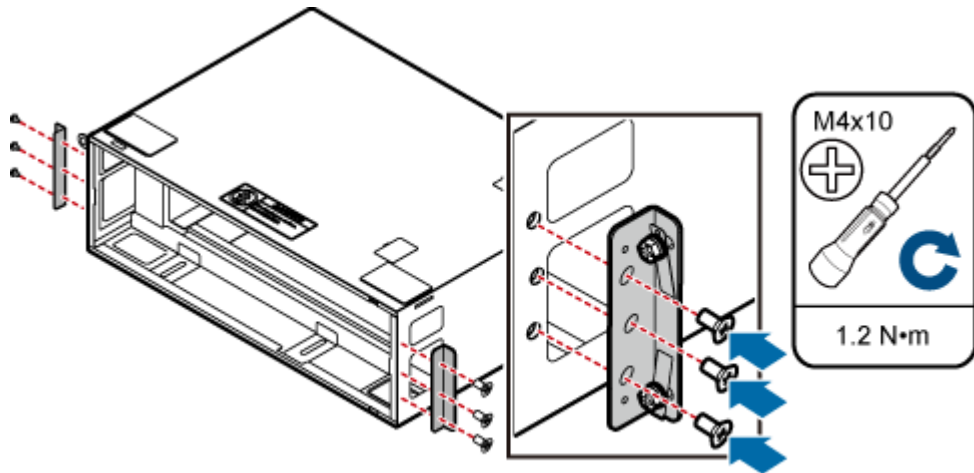

DID02-LOP0T1-B03

Step 3 Secure the IMB03 to the feet of the ICR, as shown in [Figure 11-9](#).

Figure 11-9 Securing the IMB03 to the feet of the ICR

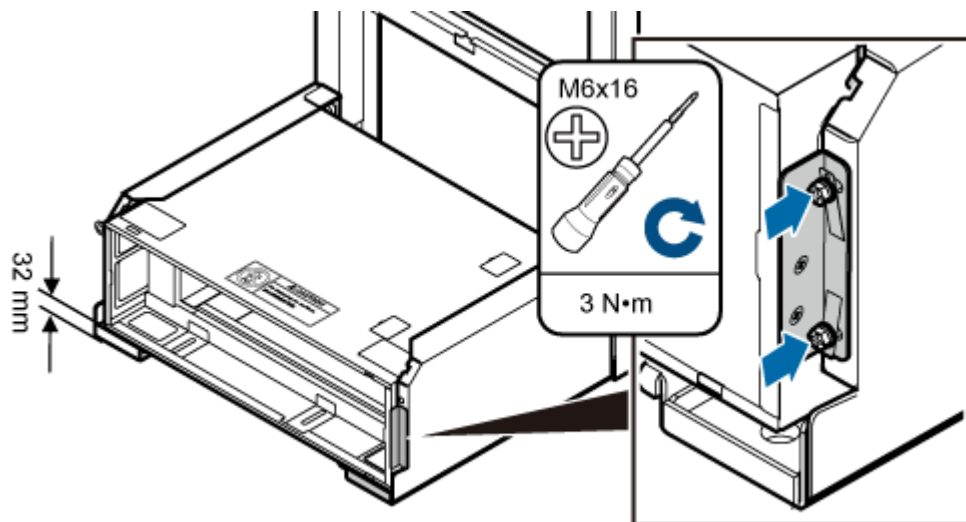

DID02-LOP0T1-B05

Step 4 Remove the protection plates from the top and bottom of the upper-level IMB03, as shown in [Figure 11-10](#).

Figure 11-10 Removing the protection plates from the upper-level IMB03

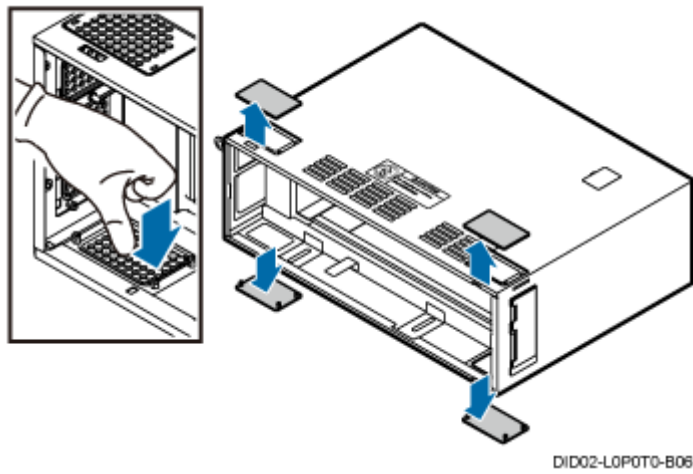

Step 5 Install mounting ears horizontally on the upper-level IMB03, as shown in [Figure 11-11](#).

Figure 11-11 Installing mounting ears horizontally on the upper-level IMB03

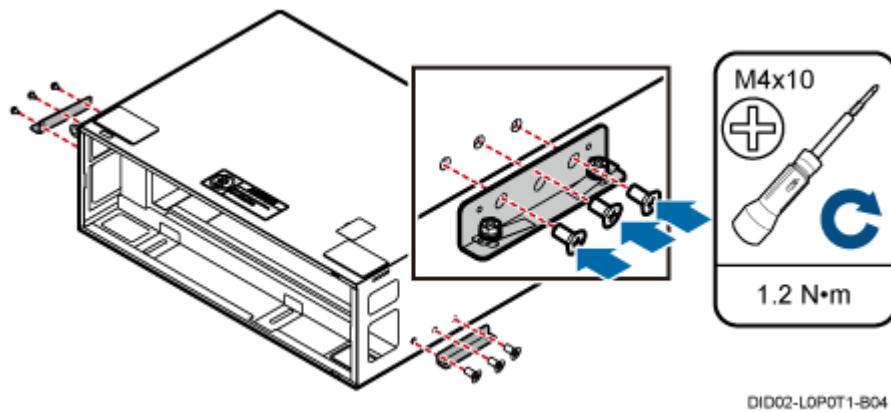

Step 6 Secure the IMB03 to the feet of the ICR, as shown in [Figure 11-12](#).

Figure 11-12 Securing the IMB03 to the feet of the ICR

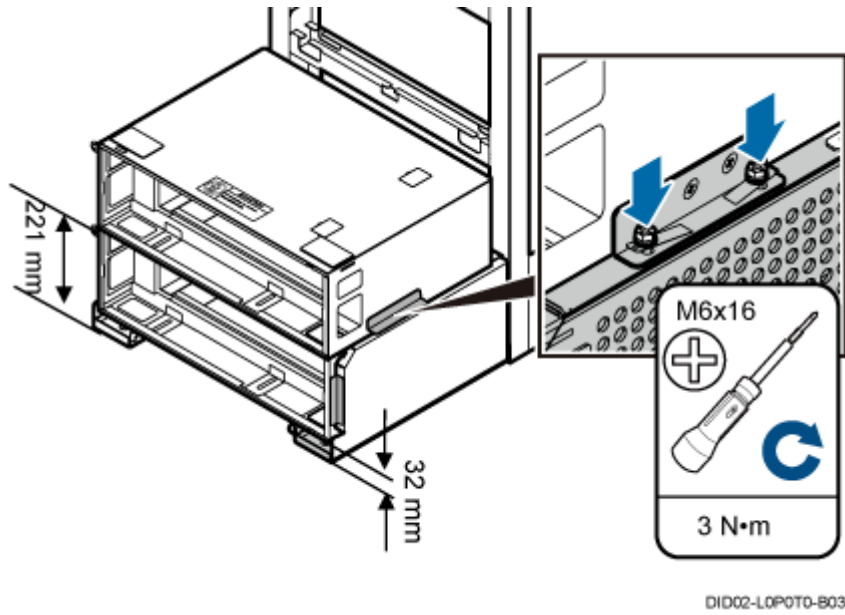

----End

12 Installing the Equipotential Cable and PGND Cable

This chapter describes the procedures for installing the equipotential cable and PGND cable.

Context

Figure 12-1 shows the installation of the equipotential cable and PGND cable.

Figure 12-1 Installation of the equipotential cable and PGND cable

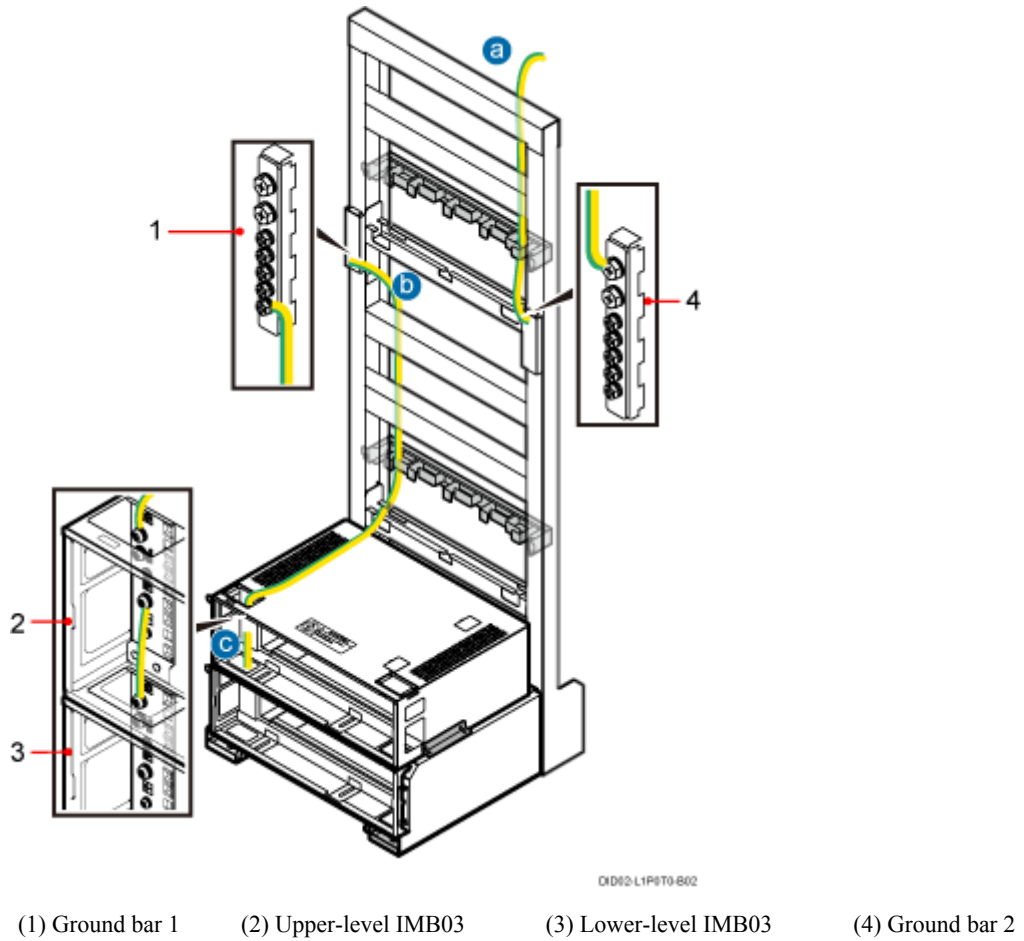

Procedure

- Step 1** Connect the PGND cable for the ICR.
- Step 2** Connect the equipotential cable between the IFS06 and the IMB03.
- Step 3** Install the equipotential cable between the IMB03s on the upper and lower levels.

Cable Id	Cable	Connector	Installation Position
a	PGND cable for the ICR	OT terminal (16 mm ² , M8)	Ground terminal on ground bar 2 of the IFS06
		OT terminal added based on actual requirement	External ground bar
b	Equipotential cable between the IFS06 and the IMB03	OT terminal (16 mm ² , M6)	Ground terminal on ground bar 1 of the IFS06
		OT terminal (16 mm ² , M6)	Ground terminal on the upper-level IMB03

Cable Id	Cable	Connector	Installation Position
c	Equipotential cable between the IMB03s on the upper and lower levels	OT terminal (6 mm ² , M4)	Ground terminal on the upper-level IMB03
		OT terminal (6 mm ² , M4)	Ground terminal on the lower-level IMB03

Step 4 Route cables by referring to [15.1 Cabling Requirements](#).

Step 5 Use cable ties to bind cables.

Step 6 Label the installed cables by referring to Attaching a Sign Plate Label.

----End

13 Installing Devices in the IMB03

About This Chapter

This chapter describes the installation of the devices in the IMB03.

Context

Before installing devices, you need to determine the number of IMB03 racks and the devices to be installed in the IMB03 according to [3.2 Installation Options](#), and then install the devices according to the slot description. [Figure 13-1](#) shows the installation slots of the DCDU-03B, BBU, and power supply system in the IMB03.

Figure 13-1 Configurations of the slots in the IMB03

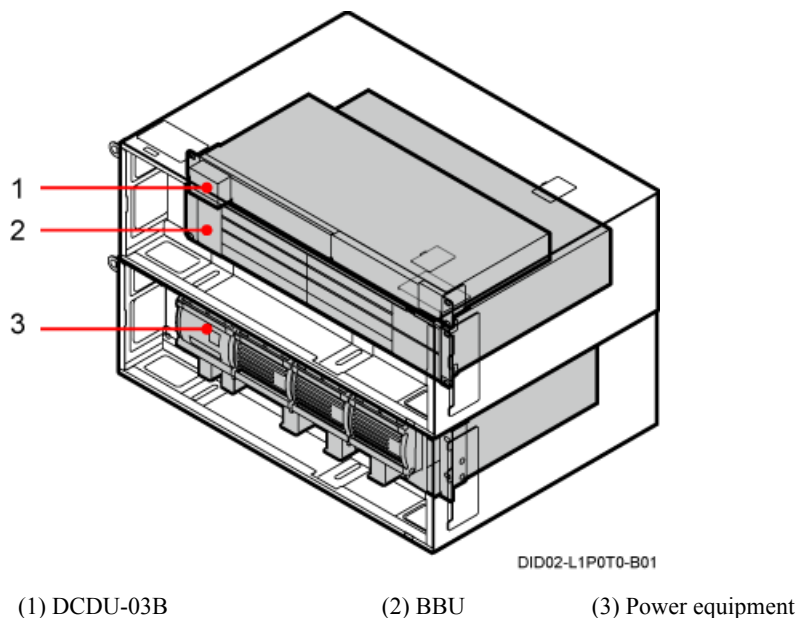

13.1 Installing the BBU

This section describes the procedure for installing the BBU in the IMB03.

Procedure

Step 1 Install the mounting ears on both sides of the BBU reversely.

1. Remove the mounting ears, as shown in [Figure 13-2](#).

Figure 13-2 Removing the mounting ears

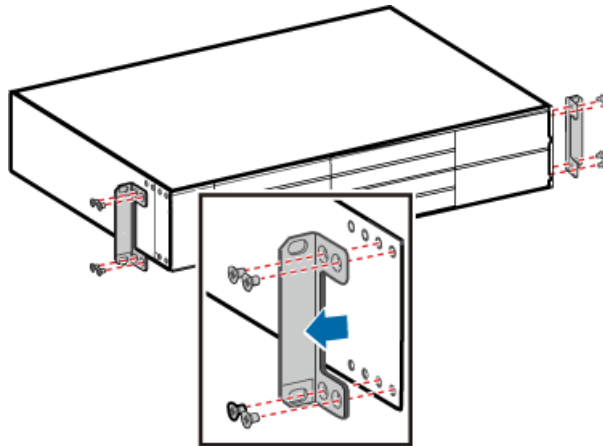

HIB01C0002

2. Install the mounting ears reversely, as shown in [Figure 13-3](#).

Figure 13-3 Installing the mounting ears reversely

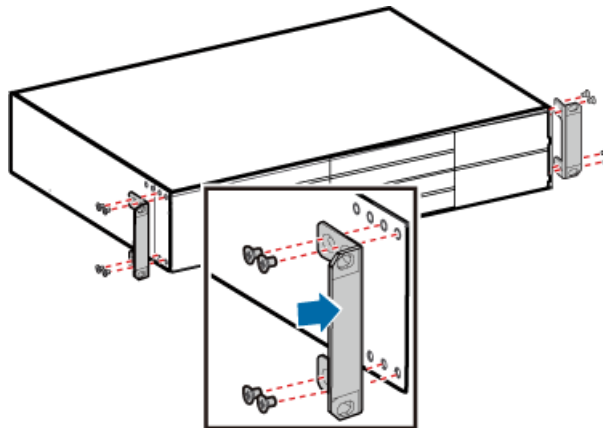

HIB01C0003

Step 2 Install the BBU into the corresponding slot in the IMB03, and then tighten the four M6x16 bolts on the panel, as shown in [Figure 13-4](#).

Figure 13-4 Installing the BBU into the slot in the IMB03

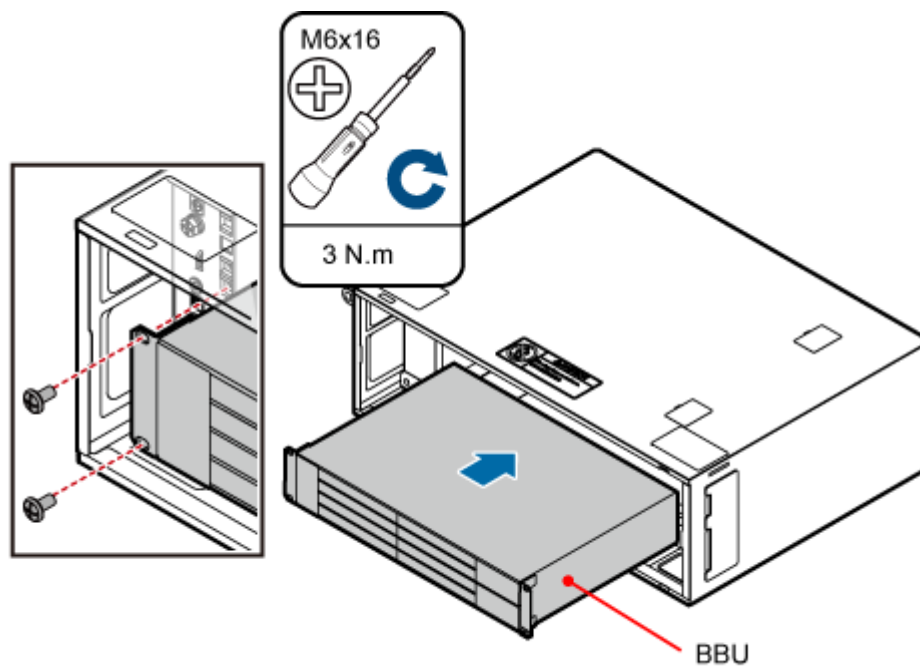

DID04-L0P0T1-P01

---End

13.2 Installing the DCDU-03B

This section describes the procedure for installing the DCDU-03B in the IMB03.

Context

The cross-section area of the PGND cable for DCDU-03B is 16 mm².

Procedure

- Step 1** Install the DCDU-03B into the corresponding slot in the IMB03, and then tighten the four M6x16 bolts on the panel, as shown in [Figure 13-5](#).

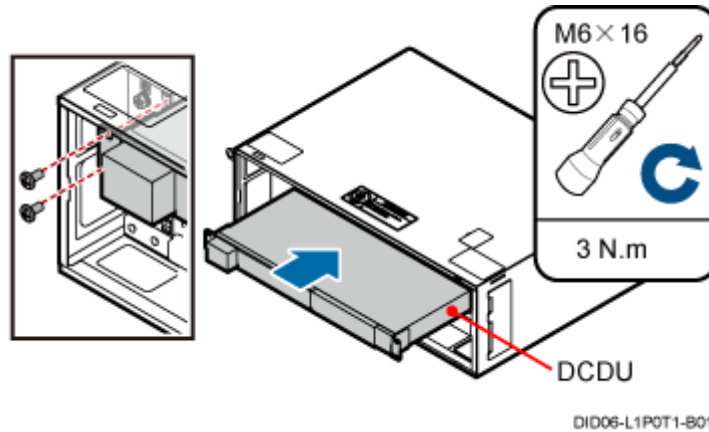
Figure 13-5 Installing the DCDU-03B into the slot in the IMB03

Step 2 Install the PGND cable for the DCDU-03B, as shown in [Figure 13-6](#).

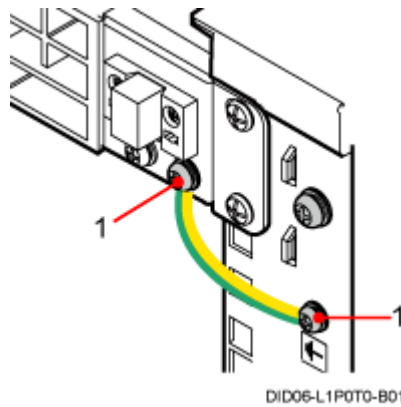
Figure 13-6 Installing the PGND cable for the DCDU-03B

(1) OT terminal (M4)

---End

13.3 (Optional) Installing the Power Equipment (DC/DC)

This section describes the procedure for installing the power equipment (DC/DC) in the IMB03.

Context

The installation of the power equipment (DC/DC) is required in the +24 V DC power supply scenario.

Procedure

Step 1 Remove the mounting ears and reinstall them backwards on the power equipment (DC/DC), as shown in [Figure 13-7](#).

Figure 13-7 Reinstalling the mounting ears

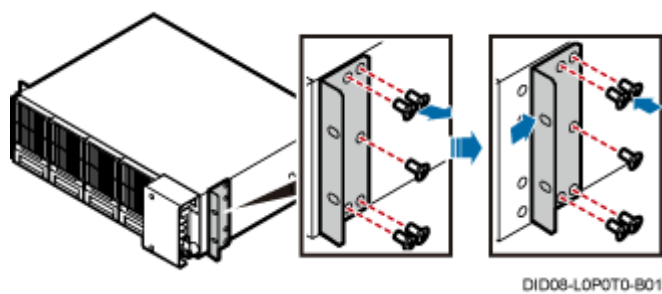

Step 2 Install the power equipment (DC/DC) into the corresponding slot in the lower-level IMB03, and then tighten the four M6x16 bolts on the panel, as shown in **Figure 13-8**.

Figure 13-8 Installing the power equipment (DC/DC) in the IMB03

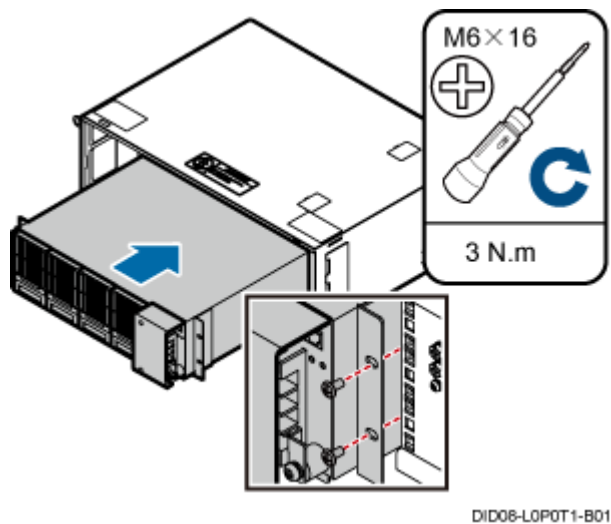

Step 3 Install the PGND cable, as shown in **Figure 13-9**.

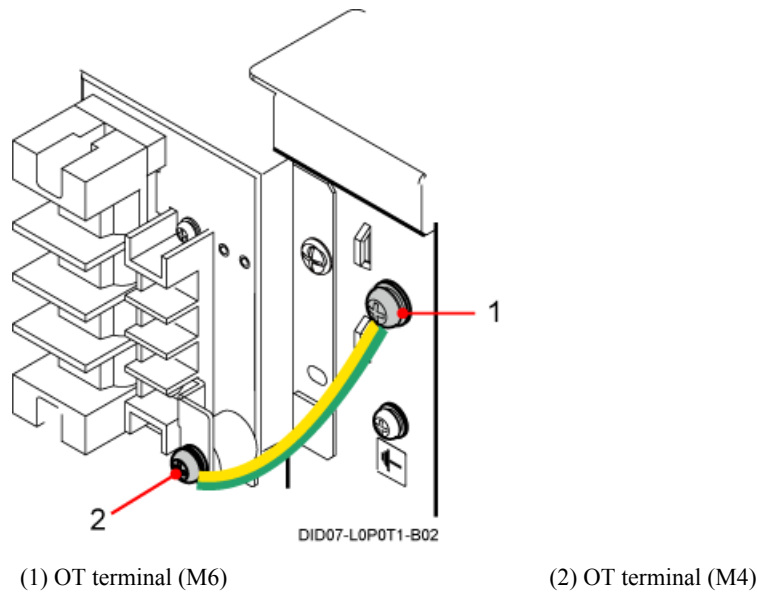
Figure 13-9 Installing the PGND cable for the power equipment (DC/DC)

----End

13.4 (Optional) Installing the Power Equipment (AC/DC)

This section describes the procedure for installing the power equipment (AC/DC) in the IMB03.

Context

The installation of the power equipment (AC/DC) is required in the 220 V AC power supply scenario.

Procedure

- Step 1** Install the power equipment (AC/DC) into the corresponding slot in the lower-level IMB03, and then tighten the four M6x16 bolts on the panel, as shown in [Figure 13-10](#).

Figure 13-10 Installing the power equipment (AC/DC) in the IMB03

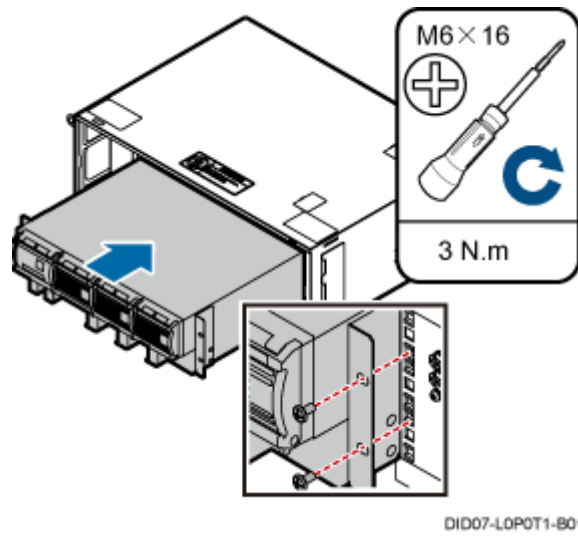

Step 2 Install the PGND cable for the power equipment (AC/DC), as shown in [Figure 13-11](#).

Figure 13-11 Installing the PGND cable for the power equipment (AC/DC)

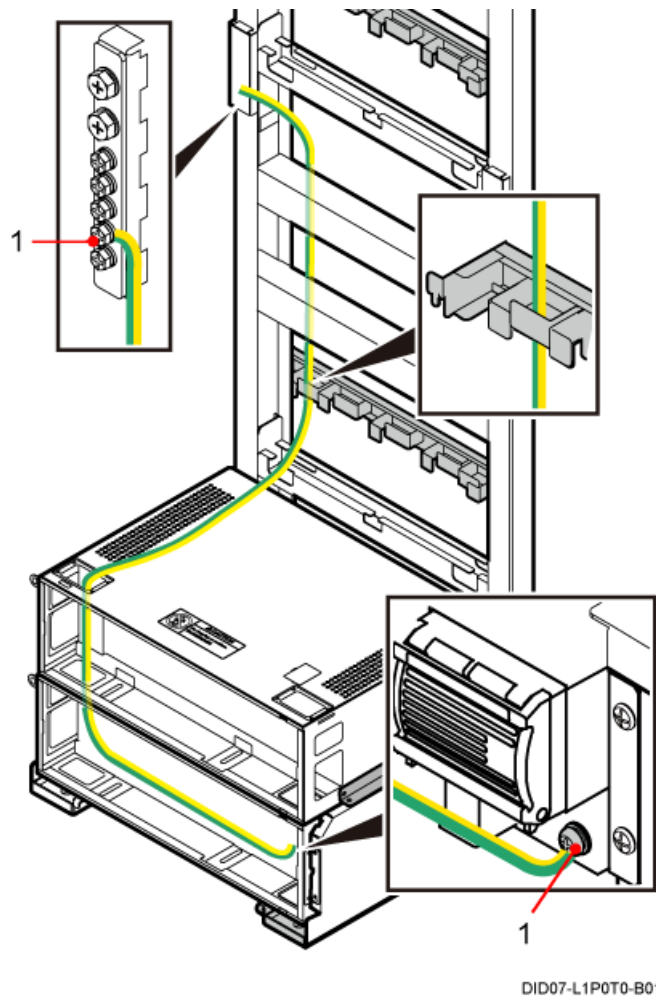

(1) OT terminal (M6)

---End

14 Installing the RRU

About This Chapter

This section describes the procedure for installing the AC RRU and DC RRU.

[14.1 Installing the DC RRU](#)

This section describes the procedure for installing the DC RRU.

[14.2 Installing the AC RRU](#)

This section describes the procedure for installing the AC RRU.

14.1 Installing the DC RRU

This section describes the procedure for installing the DC RRU.

Context

The procedures for installing the DC RRU in the IFS06+IMB03+RRU scenario and in the IFS06+RRU scenario are the same. This document takes the IFS06+IMB03+RRU scenario as an example.

The procedure for installing the RRU3008, RRU3805, RRU3804, RRU3201, or RRU3908 is the same. This document takes the RRU3908 as an example.

NOTE

- Place the foam pad or cardboard under the RRU to prevent any damage to the housing of the RRU.
- The load-bearing capacity of the RF ports at the bottom of the RRU is low. Do not stand the RRU upright.
- The screws for securing the adapting piece that are removed from the back of the RRU are reused for installing the adapting piece on the side.
- You must remove screws from the side of the RRU3008, RRU3908, or RRU3805 before installing the adapting piece, as shown in [Figure 14-2](#). For other types of RRU, skip the step.

Procedure

Step 1 Exchange the positions for the adapting piece at the back of the RRU and cover plate on the side of the RRU.

1. Remove the adapting piece at the back of the RRU and cover plate on the side of the RRU, as shown in [Figure 14-1](#).

Figure 14-1 Removing the adapting piece and cover plate

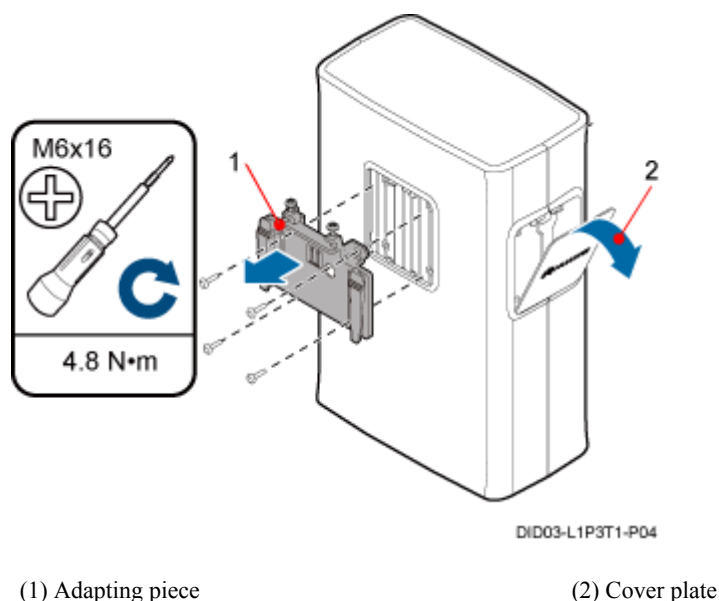

2. Remove the screws, as shown in [Figure 14-2](#).

Figure 14-2 Removing the screws

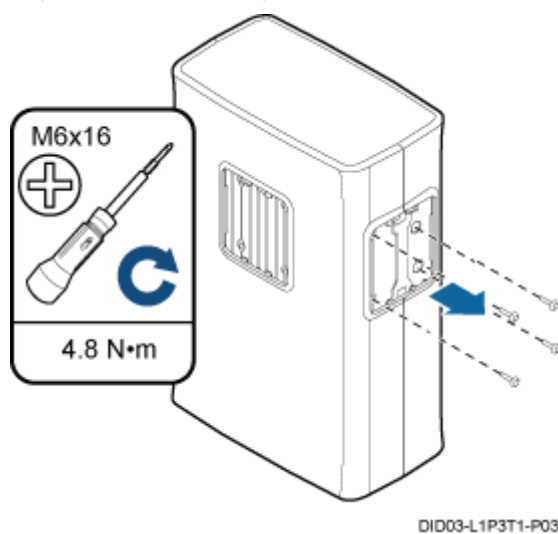

3. Reinstall the adapting piece and cover plate on the RRU, as shown in [Figure 14-3](#).

Figure 14-3 Reinstalling the adapting piece and cover plate

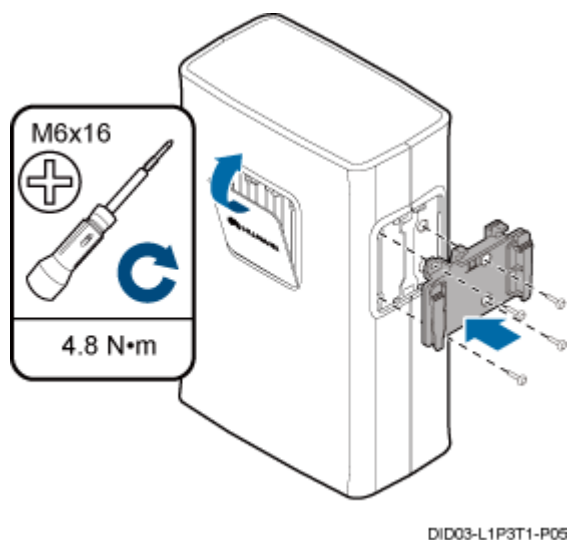

- Step 2** Link the M6 OT terminal at one end of the PGND cable to the wiring terminal at the bottom of the RRU, and leave the other end idle, as shown in [Figure 14-4](#).

Figure 14-4 Connecting the PGND cable for the RRU to the wiring terminal at the bottom

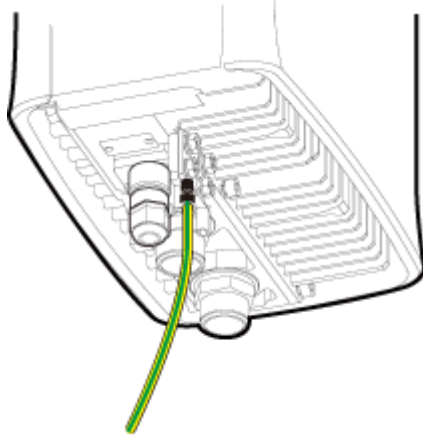

DID03-L1P3T0-P01

Step 3 Install the RRU on the main bracket, as shown in [Figure 14-5](#).

Figure 14-5 Installing the RRU on the main bracket

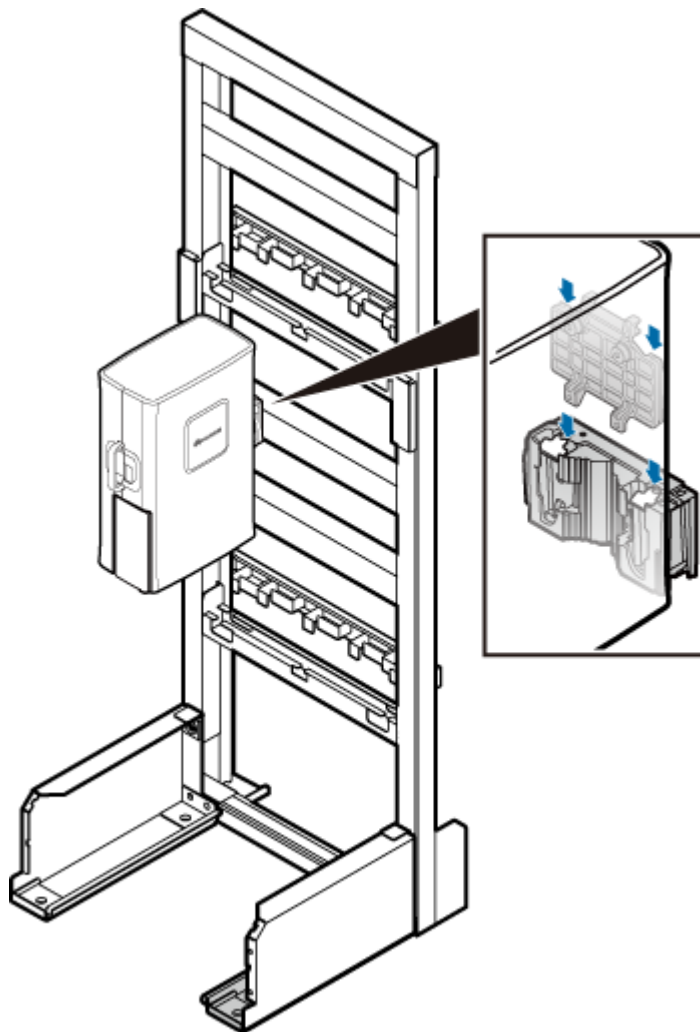

DID03-L0P3T0-P01

 **CAUTION**

Do not step on the IMB03 during the RRU installation.

- Step 4** Repeat **Step 1**, **Step 2**, and **Step 3** to install three RRUs, six RRUs, or 12 RRUs, as shown in **Figure 14-6**.

Figure 14-6 Installing six RRUs

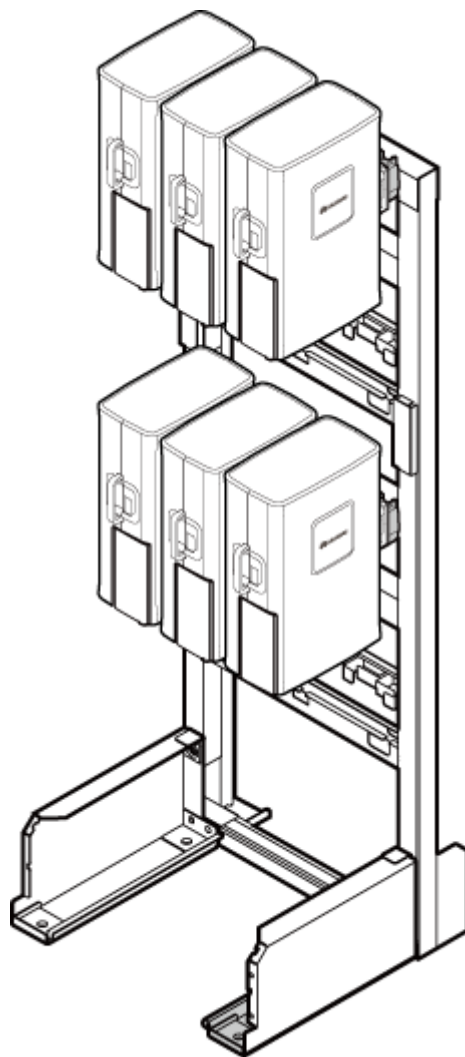

D1D03-L0P3T0-P02

---End

14.2 Installing the AC RRU

This section describes the procedure for installing the AC RRU.

Context

NOTE

- Place the foam pad or cardboard under the RRU to prevent any damage to the housing of the RRU.
- The load-bearing capacity of the RF ports at the bottom of the RRU is low. Do not stand the RRU upright.

Procedure

- Step 1** Link the M6 OT terminal at one end of the PGND cable to the wiring terminal at the bottom of the RRU, and leave the other end idle, as shown in [Figure 14-7](#).

Figure 14-7 Connecting the PGND cable for the RRU to the wiring terminal at the bottom

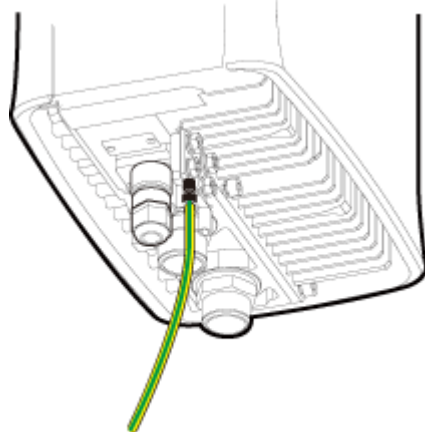

DID03-L1P3T0-P01

- Step 2** Install the AC RRU on the main bracket, as shown in [Figure 14-8](#).

Figure 14-8 Installing the AC RRU on the main bracket

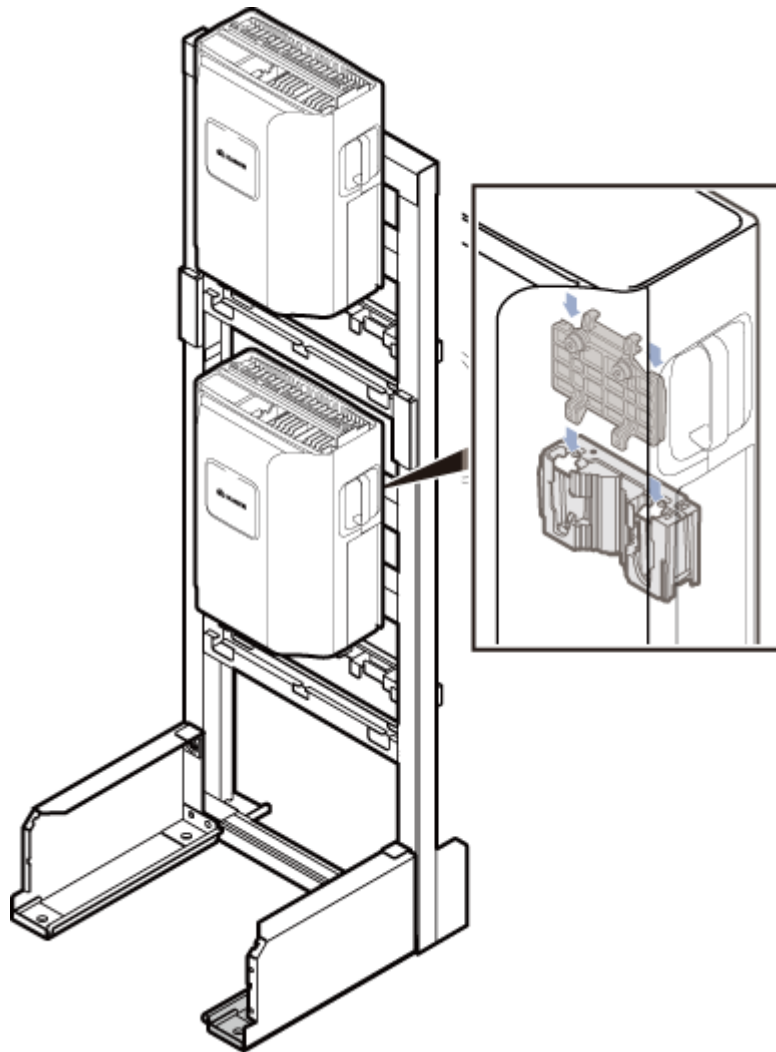

DID03-L0P1T0-P02

 **NOTE**

Install the AC RRU on the lower level before installing the RRU on the upper level.

----**End**

15 Installing Cables

About This Chapter

This chapter describes the procedure for installing all the cables.

[15.1 Cabling Requirements](#)

Route cables according to the specified cabling requirements to prevent signal interference.

[15.2 Cable Connections](#)

This section describes the cable connections in different scenarios.

[15.3 Cable Installation Process](#)

This section describes the process of installing the ICR-related cables.

[15.4 Cable Routes](#)

This section describes the cable routes.

[15.5 Installing the PGND Cable for the RRU](#)

This section describes the procedure for installing the PGND cable for the RRU.

[15.6 Installing the Power Cable for the BBU](#)

This section describes the installation of the power cable for the BBU.

[15.7 Installing the Input Power Cable](#)

This section describes the installation of the input power cable.

[15.8 \(Optional\) Installing the Power Cable and Monitoring Signal Cable for the DCDU](#)

This section describes the procedure for installing the power cable and monitoring signal cable.

[15.9 Installing the Power Cable for the RRU](#)

This section describes the installation of the power cable for the RRU.

[15.10 Installing the E1/T1 Cable \(FE/GE Cable or FE/GE Optical Cable\)](#)

This section describes the installation of the E1/T1 cable, FE/GE cable, and FE/GE optical cable. The FE/GE cable and FE/GE optical cable are optional. The following description is based on the installation of the E1/T1 cable.

[15.11 Installing the CPRI Optical Cable](#)

This section describes the procedure for installing the CPRI optical cable.

[15.12 Installing the Antenna Jumper for the RRU](#)

This section describes the procedure for installing the antenna jumper for the DC RRU.

[15.13 Installing a GPS Clock Signal Cable](#)

This section describes the procedure for installing the GPS clock signal cable.

15.1 Cabling Requirements

Route cables according to the specified cabling requirements to prevent signal interference.



NOTE

If a cable listed below is not required, skip the routing of the cable.

General Cabling Requirements

The bending radius of the cables must meet the following specifications:

- The bending radius of the 7/8" feeder must be more than 250 mm (9.84 in.), and the bending radius of the 5/4" feeder must be more than 380 mm (14.96 in.).
- The bending radius of the 1/4" jumper must be more than 35 mm (1.38 in.). The bending radius of the super-flexible 1/2" jumper must be more than 50 mm (1.97 in.), and the bending radius of the ordinary 1/2" jumper must be more than 127 mm (5 in.).
- The bending radius of the power cable or PGND cable must be at least five times the diameter of the cable.
- The bending radius of the optical fiber must be at least 20 times the diameter of the optical fiber.
- The bending radius of the E1/T1 cable must be at least five times the diameter of the cable.
- The bending radius of the signal cable must be at least five times the diameter of the cable.

The cables must be bound as follows:

- Different types of cables must be separately routed and cannot be entangled.
- The cables must be bound tightly and neatly. The sheaths of the cables must not be damaged.
- The cable ties must face the same direction, and those at the same horizontal line must be in a straight line. Extra length of cable ties must be cut.
- Labels or nameplates must be attached to the cables after they are installed.

The cables must be routed as follows:

- Different types of cables must be separately routed with a minimum space of 30 mm (1.18 in.) between every two cables.
- Different types of cables must be installed in an untangled and orderly fashion.
- Different types of cables must be routed in parallel or separated by special objects.

Special Cabling Requirements

Cabling requirements for power cables are as follows:

- -48 V DC power cables must be bound together.
- +24 V DC power cables must be bound together.
- Power cables, transmission cables, and signal cables are routed separately.
- Multiple power cables must be bound when routed.
- Power cables must be installed in the position specified in engineering design documents.
- If the length of power cables is insufficient, replace the cables rather than adding connectors or soldering joints to lengthen the cables.

Cabling requirements for PGND cables are as follows:

- PGND cables for the base station must be connected to the same ground bar.
- PGND cables must be buried in the ground or routed indoors. They should not be routed overhead before they are led into the equipment room.
- The exterior of the coaxial wire and the shield layer of the shielded cable must have proper electrical contact with the metal surface of the equipment to which they are connected.
- PGND cables and signal cables must be installed in an untangled and orderly fashion. A certain distance must be reserved between them to prevent interference from each other.
- Fuses or switches must not be installed on the PGND cables.
- Other devices must not be used for electrical connections of the PGND cables.
- All the metal parts in the housing of the equipment must be reliably connected to the ground terminal.

Cabling requirements for E1 cables are as follows:

- E1 cables must not cross power cables, PGND cables, or RF cables when routed. If transmission cables are routed with power cables, PGND cables, or RF cables in parallel, the spacing between them must be greater than 30 mm (1.18 in.).
- E1 cables are routed straightly and bound neatly with cable ties.
- Sufficient slack is provided in E1 cables at turns.

Cabling requirements for optical fibers are as follows:

- Do not stretch, step on, or place heavy objects on optical fibers. Keep the fibers away from sharp objects.
- When optical fibers are routed, the extra length of the fibers must be coiled around special devices, such as a fiber coiler.
- When coiling optical fibers, apply even strength. Do not bend the fibers with force.
- Vacant optical connectors must be covered with dustproof caps.

15.2 Cable Connections

This section describes the cable connections in different scenarios.

[15.2.1 Cable Connections \(-48 V DC, Six RRU3008s\)](#)

This section describes all the cable connections in a base station configured with six RRU3008s in the -48 V DC power supply scenario.

[15.2.2 Cable Connections \(-48 V DC, Six RRU3804s\)](#)

This section describes all the cable connections in a base station configured with six RRU3804s in the -48 V DC power supply scenario.

[15.2.3 Cable Connections \(-48 V DC, Six RRU3201s\)](#)

This section describes all the cable connections in a base station configured with six RRU3201s in the -48 V DC power supply scenario.

[15.2.4 Cable Connections \(-48 V DC, Six RRU3908s\)](#)

This section describes all the cable connections in a base station configured with six RRU3908s in the -48 V DC power supply scenario.

[15.2.5 Cable Connections \(-48 V DC, Three RRU3908s+Three RRU3804s\)](#)

This section describes all the cable connections in the dual-mode and triple-mode scenarios when three RRU3908s and three RRU3804s are configured and the -48 V DC power supply is provided.

15.2.6 Cable Connections (-48 V DC, Three RRU3008s+Three RRU3804s)

This section describes all the cable connections in a base station configured with three RRU3008s and three RRU3804s in the -48 V DC power supply scenario.

15.2.7 Cable Connections (-48 V, Three RRU3908s + Three RRU3201s)

This section describes all the cable connections in the dual-mode and triple-mode scenarios when three RRU3908s and three RRU3201s are configured and the -48 V DC power supply is provided.

15.2.8 Cable Connections (-48 V DC, Three RRU3008s+Three RRU3201s)

This section describes all the cable connections in a base station configured with three RRU3008s and three RRU3201s in the -48 V DC power supply scenario.

15.2.9 Cable Connections (-48 V DC, Three RRU3804s+Three RRU3201s)

This section describes all the cable connections in a base station configured with three RRU3804s and three RRU3201s in the -48 V DC power supply scenario.

15.2.10 Cable Connections (-48 V DC, Six RRU3008s+Six RRU3804s)

This section describes all the cable connections in a base station configured with six RRU3008s and six RRU3804s in the -48 V DC power supply scenario.

15.2.11 Cable Connections (-48 V DC, Six RRU3908s+Six RRU3804s)

This section describes all the cable connections in the dual-mode and triple-mode scenarios when six RRU3908s and six RRU3804s are configured and the -48 V DC power supply is provided.

15.2.12 Cable Connections (-48 V DC, Six RRU3908s+Six RRU3201s)

This section describes all the cable connections in the dual-mode and triple-mode scenarios when six RRU3908s and six RRU3201s are configured and the -48 V DC power supply is provided.

15.2.13 Cable Connections (-48 V DC, Six RRU3008s+Six RRU3201s)

This section describes all the cable connections in a base station configured with six RRU3008s and six RRU3201s in the -48 V DC power supply scenario.

15.2.14 Cable Connections (-48 V DC, Six RRU3804s+Six RRU3201s)

This section describes all the cable connections in a base station configured with six RRU3804s and six RRU3201s in the -48 V DC power supply scenario.

15.2.15 Cable Connections (AC RRU)

This section describes all the cable connections for the only one RRU configured in a base station with AC power supply.

15.2.16 Cable Connections (220 V AC)

This section describes the cable connections for the power equipment (AC/DC) in a base station with 220 V AC power supply.

15.2.17 Cable Connections (+24 V DC)

This section describes the cable connections for the power equipment (DC/DC) in a base station with +24 V DC power supply.

15.2.1 Cable Connections (-48 V DC, Six RRU3008s)

This section describes all the cable connections in a base station configured with six RRU3008s in the -48 V DC power supply scenario.

Figure 15-1 shows the cable connections.

Figure 15-1 Cable connections (-48 V DC, six RRU3008s)

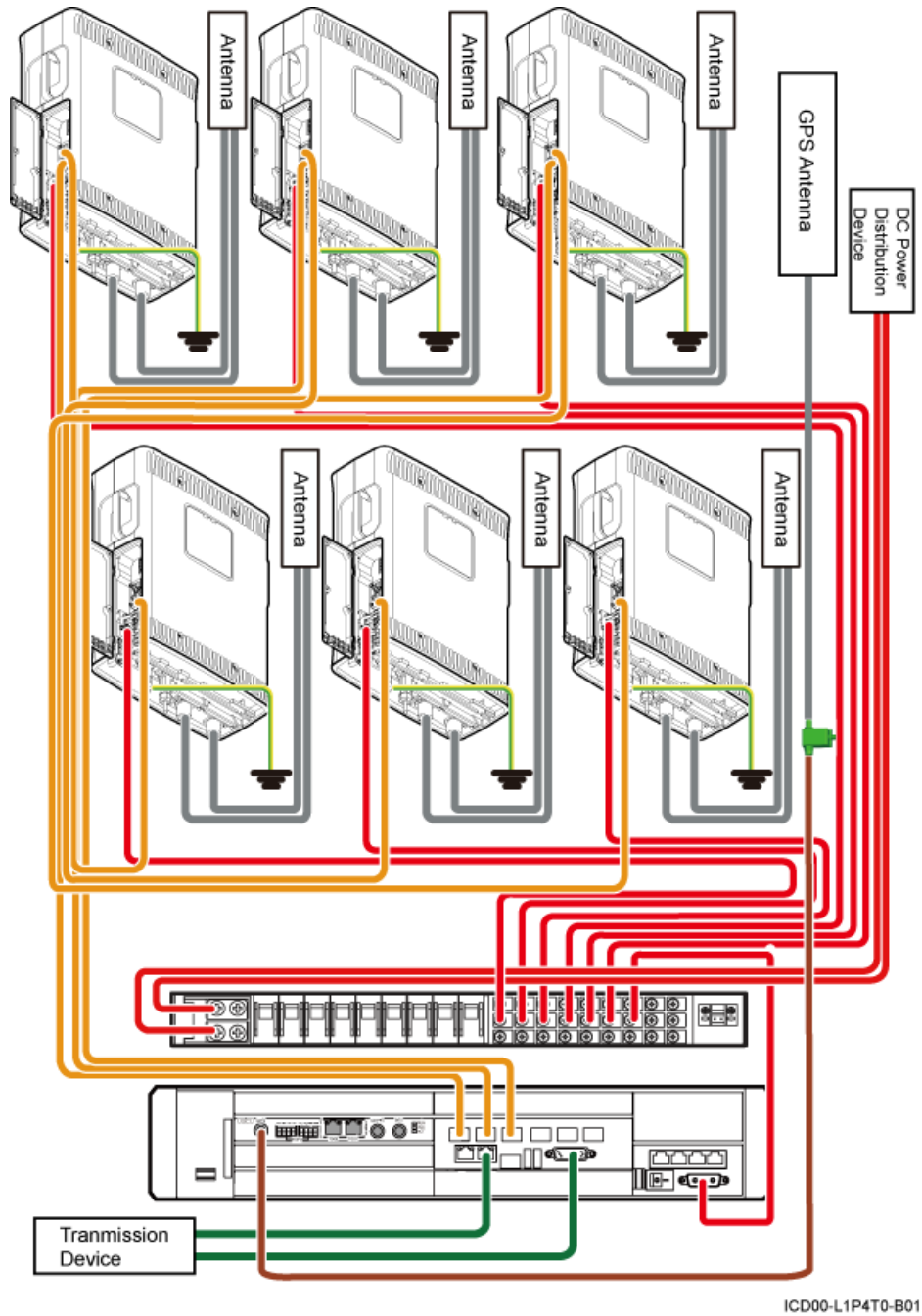







Table 15-1 describes the cables.

Table 15-1 Cable description

	Power cable		CPRI cable		GPS clock signal cable
	Jumper		PGND cable		E1/T1 cable or FE/GE cable

NOTE

The E1/T1 cable or FE/GE cable is used according to the on-site requirements.

15.2.2 Cable Connections (-48 V DC, Six RRU3804s)

This section describes all the cable connections in a base station configured with six RRU3804s in the -48 V DC power supply scenario.

Figure 15-2 shows the cable connections.



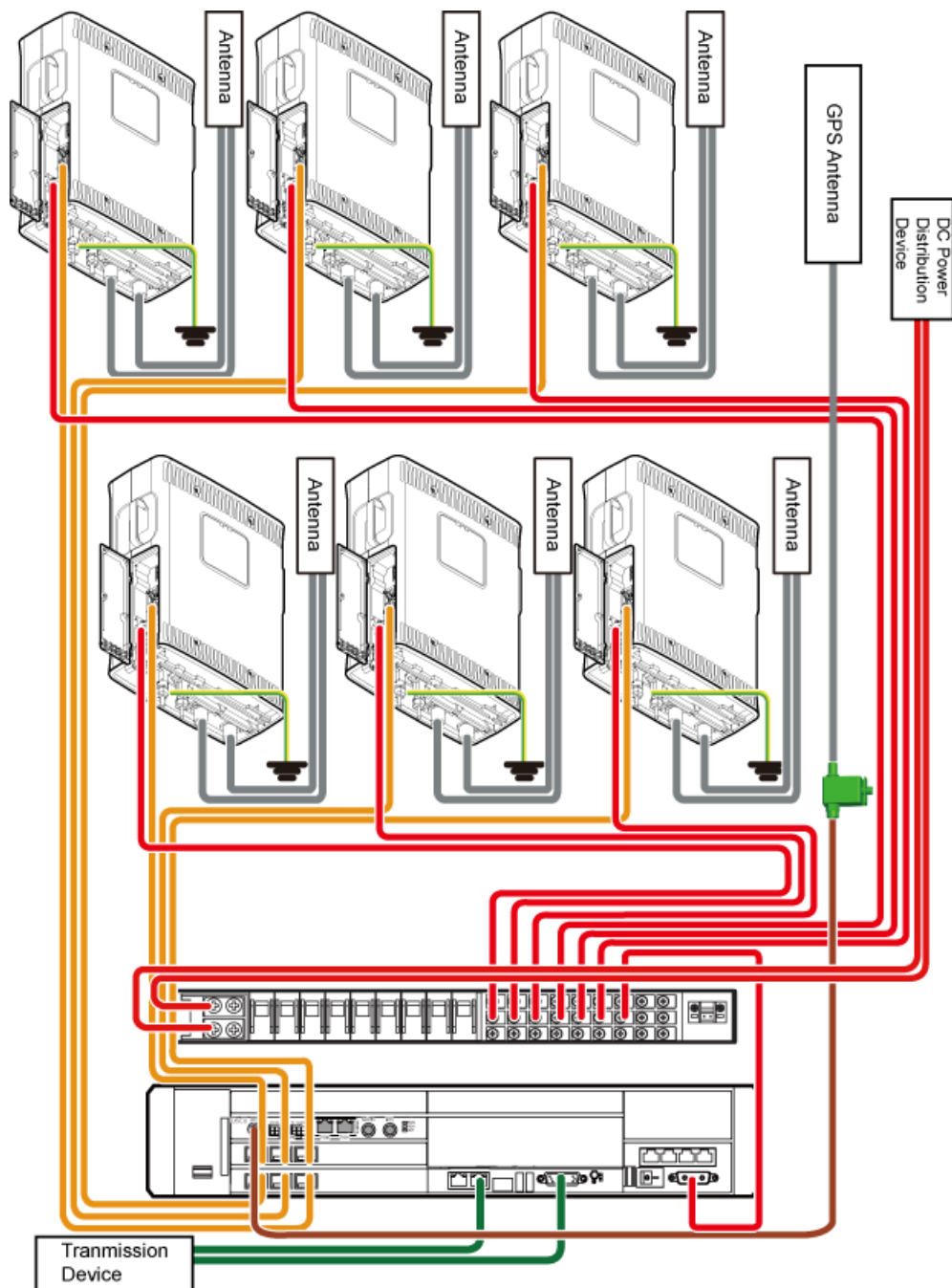



Figure 15-2 Cable connections (-48 V DC, six RRU3804s)



ICD00-L1P4T0-B02

Table 15-2 describes the cables.

Table 15-2 Cable description

	Power cable		CPRI cable		GPS clock signal cable
	Jumper		PGND cable		E1/T1 cable or FE/GE cable

 **NOTE**

The E1/T1 cable or FE/GE cable is used according to the on-site requirements.

15.2.3 Cable Connections (-48 V DC, Six RRU3201s)

This section describes all the cable connections in a base station configured with six RRU3201s in the -48 V DC power supply scenario.

Figure 15-3 shows the cable connections.



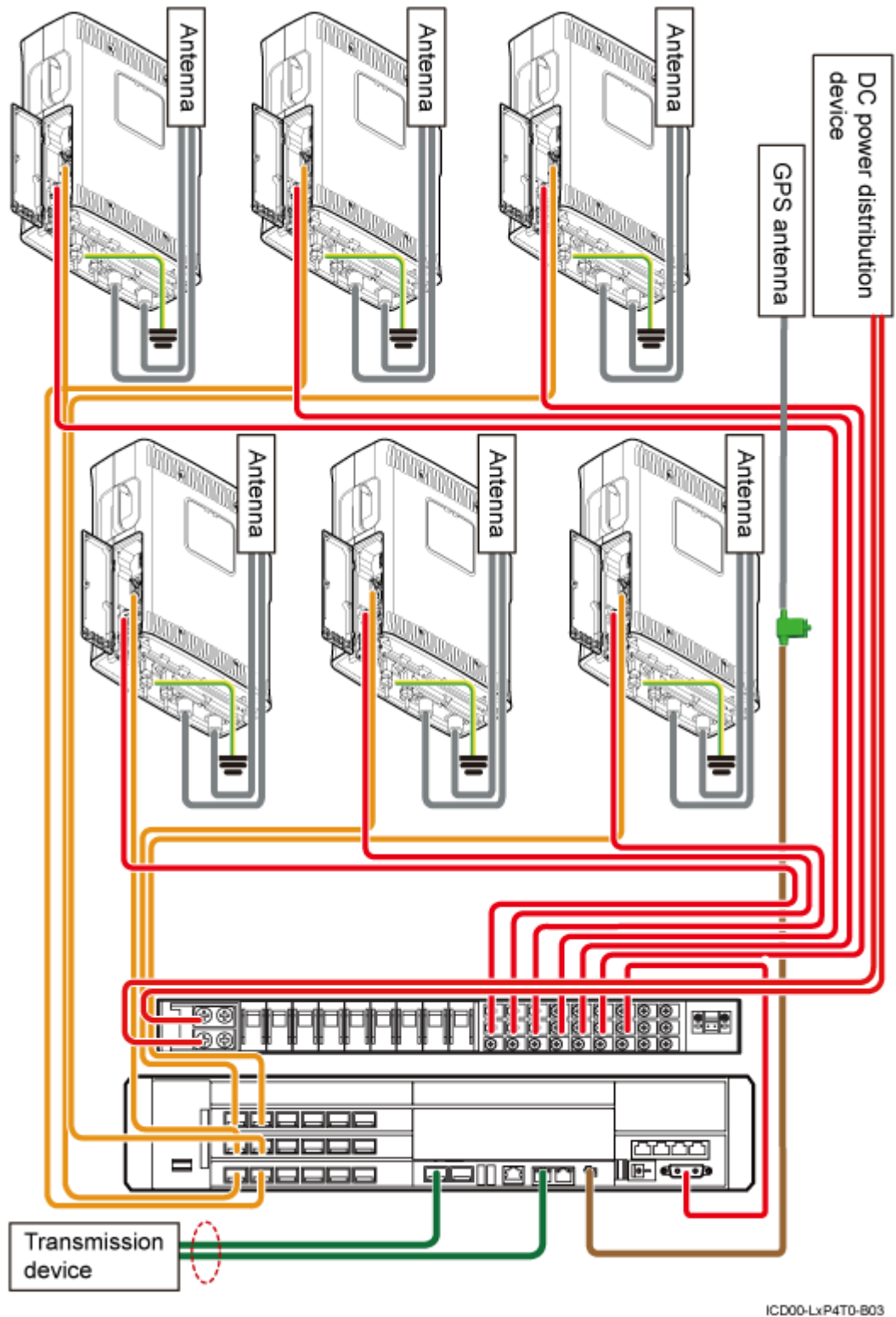



Figure 15-3 Cable connections (-48 V DC, six RRU3201s)



ICD00-LxP4T0-B03

Table 15-3 describes the cables.

Table 15-3 Cable description

	Power cable		CPRI cable		GPS clock signal cable
	Jumper		PGND cable		E1/T1 cable or FE/GE cable

 **NOTE**

Only an optical cable or Ethernet cable can be connected to a GE port on the LMPT.

15.2.4 Cable Connections (-48 V DC, Six RRU3908s)

This section describes all the cable connections in a base station configured with six RRU3908s in the -48 V DC power supply scenario.

[Figure 15-4](#) shows the cable connections.

Figure 15-4 Cable connections (-48 V DC, six RRU3908s)

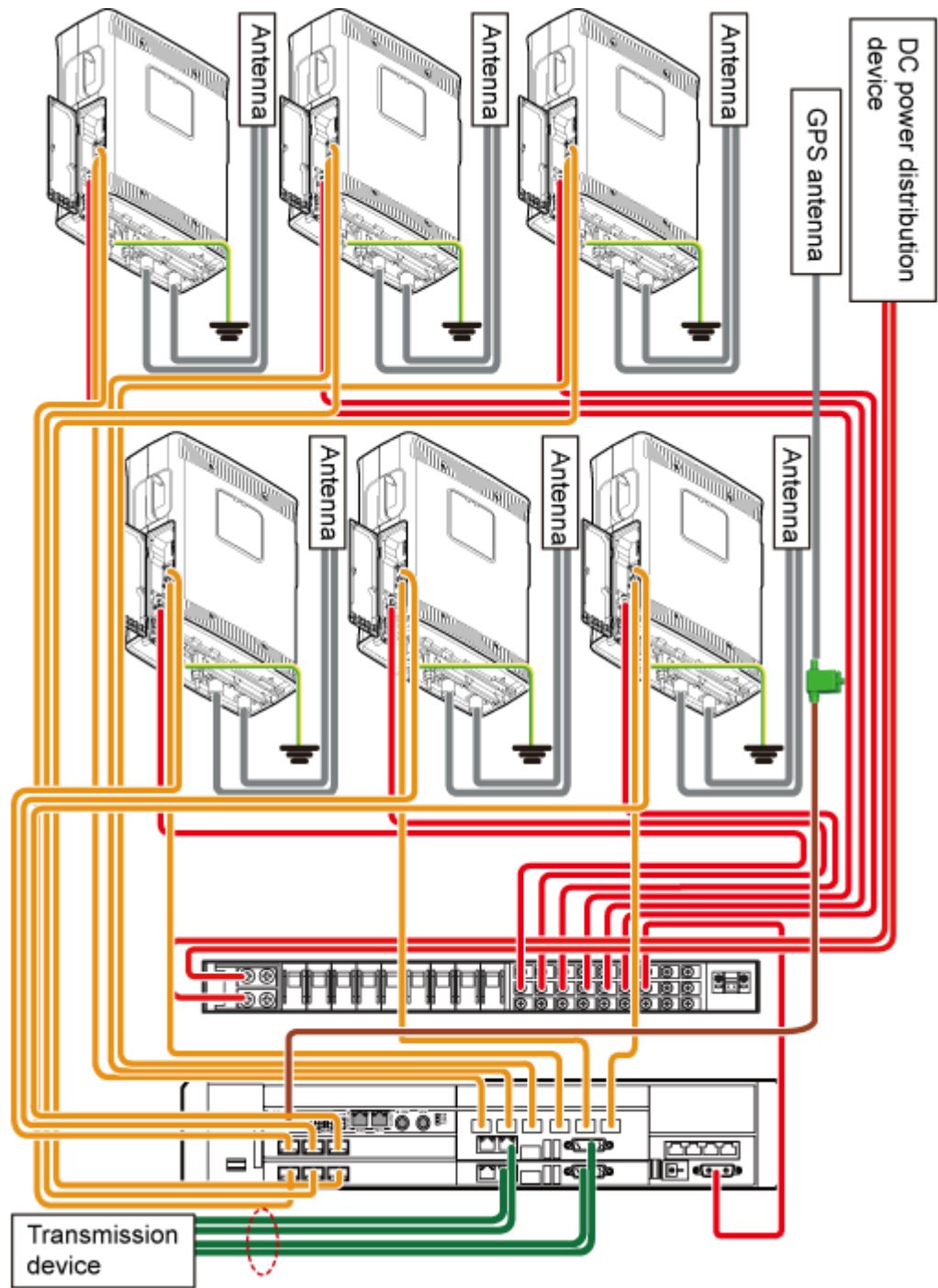



ICD00-LxP4T0-B04

Table 15-4 describes the cables.

Table 15-4 Cable description

	Power cable		CPRI cable		GPS clock signal cable
---	-------------	---	------------	---	------------------------

	Jumper		PGND cable		E1/T1 cable or FE/GE cable
---	--------	---	------------	---	----------------------------------

 **NOTE**

The E1/T1 cable or FE/GE cable is used according to the on-site requirements.

15.2.5 Cable Connections (-48 V DC, Three RRU3908s+Three RRU3804s)

This section describes all the cable connections in the dual-mode and triple-mode scenarios when three RRU3908s and three RRU3804s are configured and the -48 V DC power supply is provided.

Cable Connections in the Dual-Mode Scenario

[Figure 15-5](#) shows the cable connections in the dual-mode scenario.

Figure 15-5 Cable connections in the dual-mode scenario (-48 V, three RRU3908s + three RRU3804s)

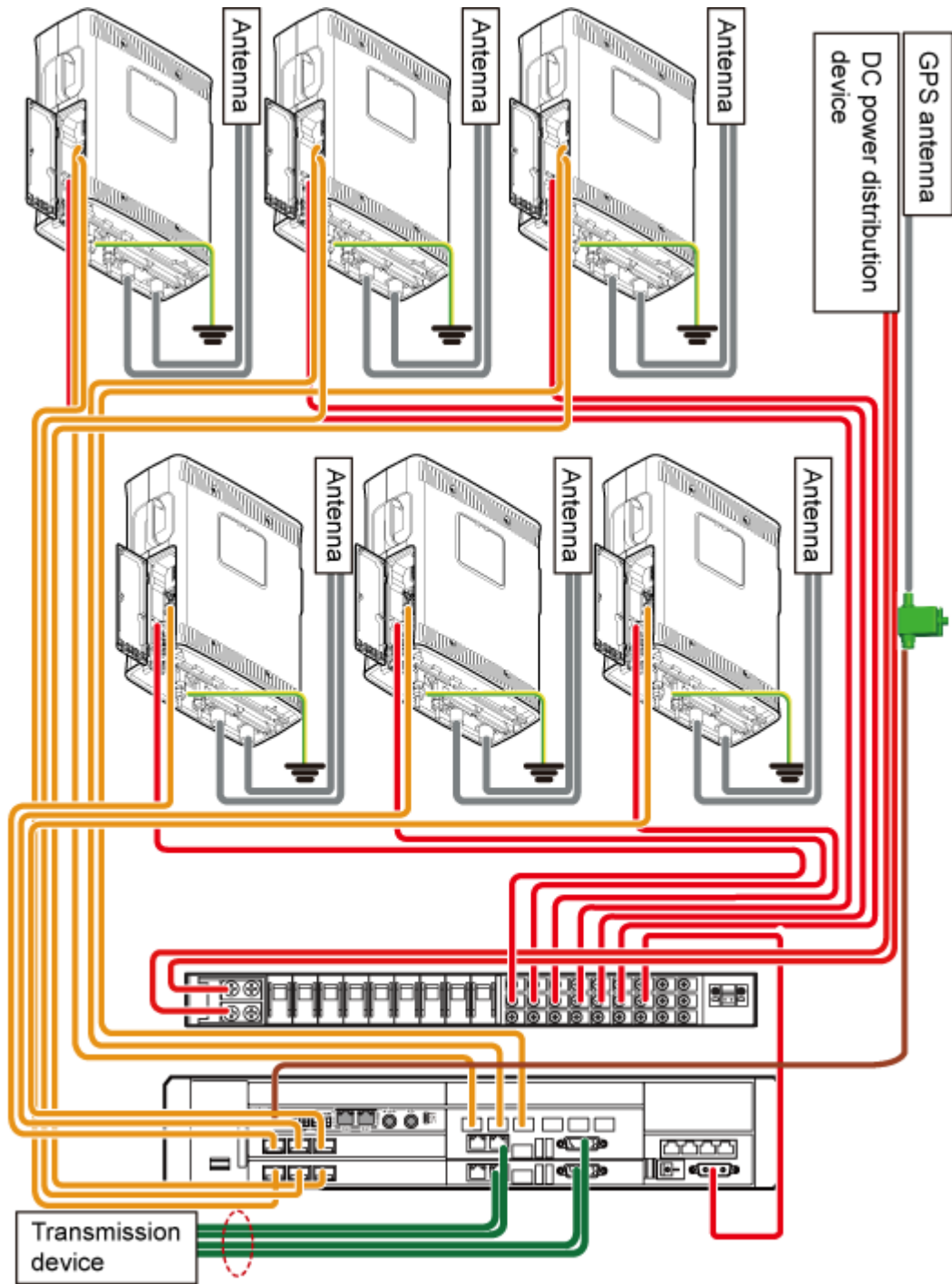



ICD00-LxP4T0-B05

Table 15-5 lists the cables.

Table 15-5 Cable description

	Power cable		CPRI optical cable		GPS clock signal cable
---	-------------	---	--------------------	---	------------------------

	Jumper		PGND Cable		E1/T1 cable or FE/GE cable
---	--------	---	------------	---	----------------------------------

 **NOTE**

The E1/T1 cable or FE/GE cable is used according to the on-site requirements.

Cable Connections in the Triple-Mode Scenario

[Figure 15-6](#) shows cable connections in the triple-mode scenario.

Figure 15-6 Cable Connections in triple-mode scenario (-48 V DC, Three RRU3908s + Three RRU3804s)

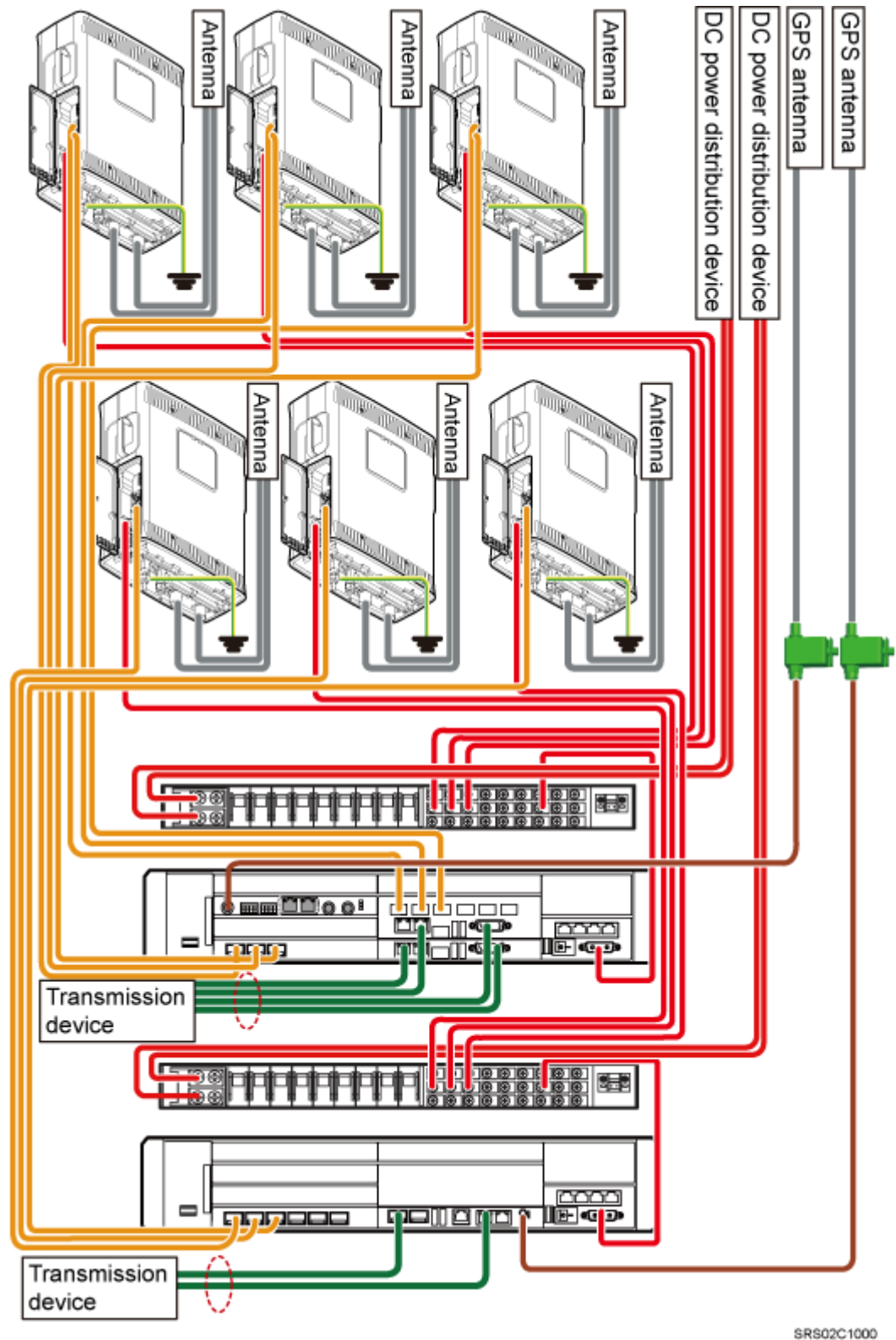







Table 15-6 lists the cables.

Table 15-6 Cable description

	Power cable		CPRI optical cable		GPS clock signal cable
	Jumper		PGND Cable		E1/T1 cable or FE/GE cable

 **NOTE**

The E1/T1 cable or FE/GE cable is used according to on-site requirements.

15.2.6 Cable Connections (-48 V DC, Three RRU3008s+Three RRU3804s)

This section describes all the cable connections in a base station configured with three RRU3008s and three RRU3804s in the -48 V DC power supply scenario.

[Figure 15-7](#) shows the cable connections.

Figure 15-7 Cable connections (-48 V DC, three RRU3008s+three RRU3804s)

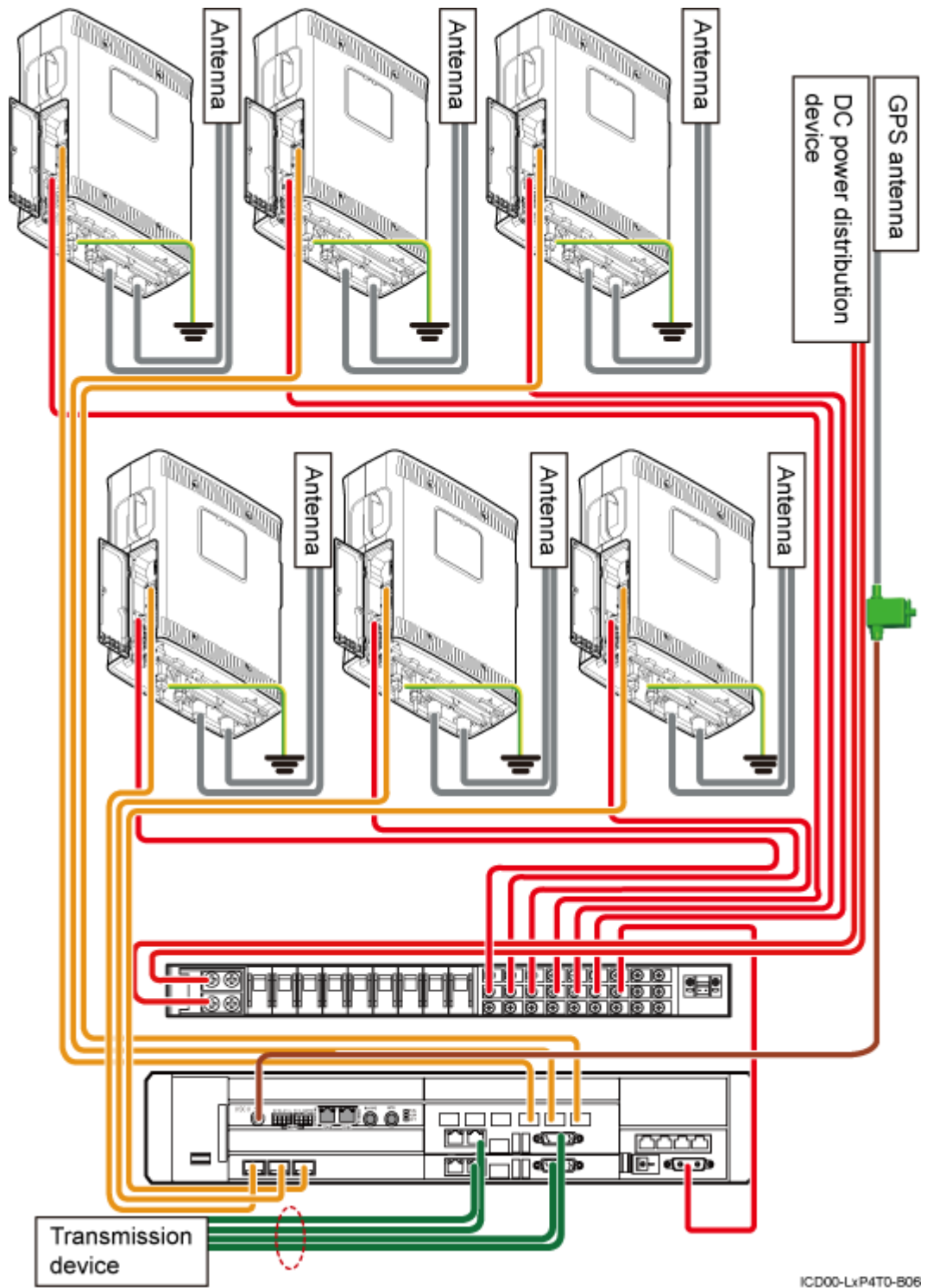







Table 15-7 describes the cables.

Table 15-7 Cable description

	Power cable		CPRI cable		GPS clock signal cable
	Jumper		PGND cable		E1/T1 cable or FE/GE cable

 **NOTE**

The E1/T1 cable or FE/GE cable is used according to the on-site requirements.

15.2.7 Cable Connections (-48 V, Three RRU3908s + Three RRU3201s)

This section describes all the cable connections in the dual-mode and triple-mode scenarios when three RRU3908s and three RRU3201s are configured and the -48 V DC power supply is provided.

Cable Connections in the Dual-Mode Scenario

Figure 15-8 shows the cable connections in the dual-mode scenario.

Figure 15-8 Cable connections in the dual-mode scenario (-48 V, three RRU3908s + three RRU3201s)

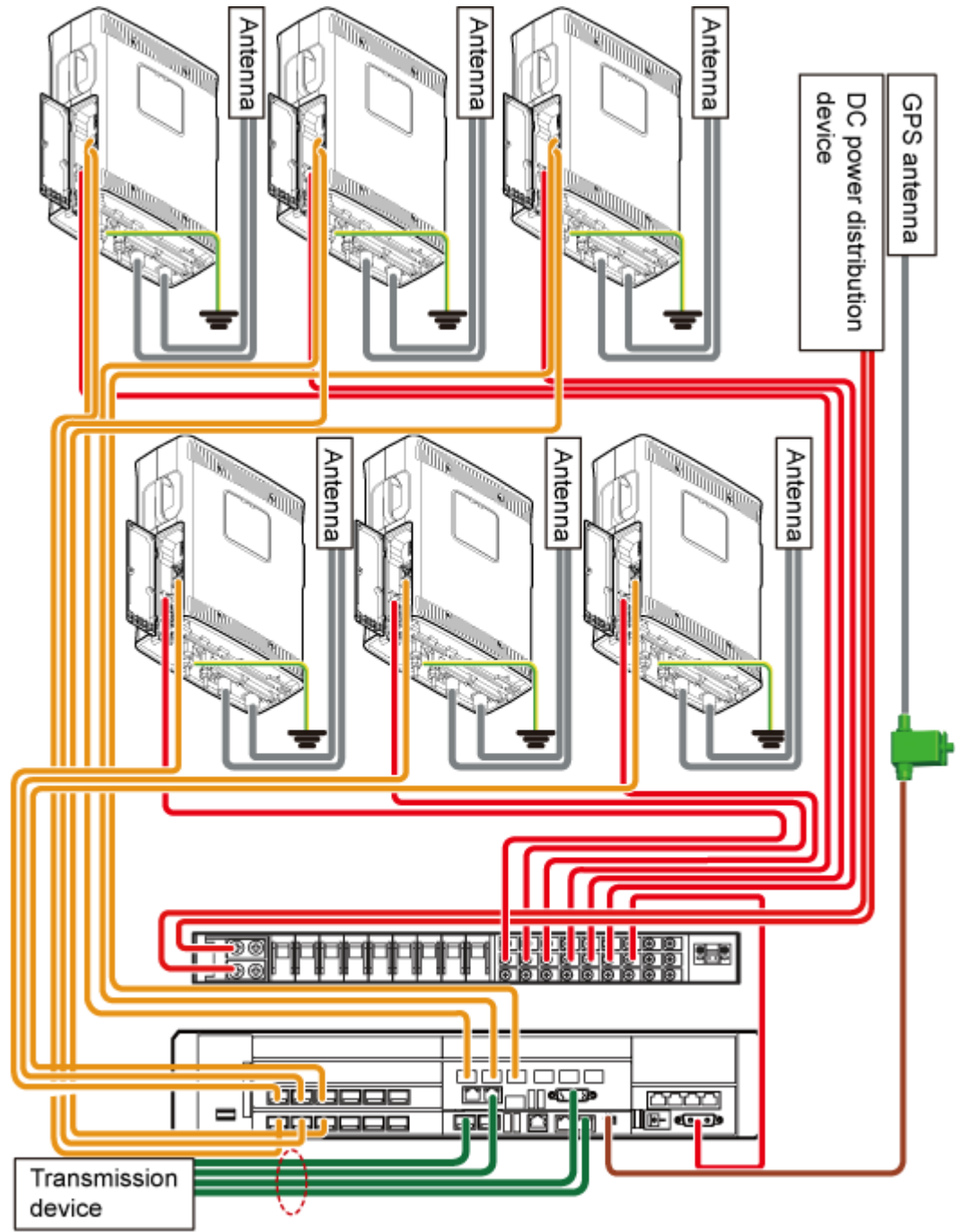



ICD00-L1P4T0-B07

Table 15-8 lists the cables.

Table 15-8 Cable description

	Power cable		CPRI optical cable		GPS clock signal cable
---	-------------	---	--------------------	---	------------------------

	Jumper		PGND cable		E1/T1 cable or FE/GE cable
---	--------	---	------------	---	----------------------------------

 **NOTE**

The E1/T1 cable or FE/GE cable is used according to on-site requirements. Only an optical cable or Ethernet cable can be connected to a GE port on the LMPT.

Cable Connections in the Triple-Mode Scenario

[Figure 15-9](#) shows cable connections in the triple-mode scenario.



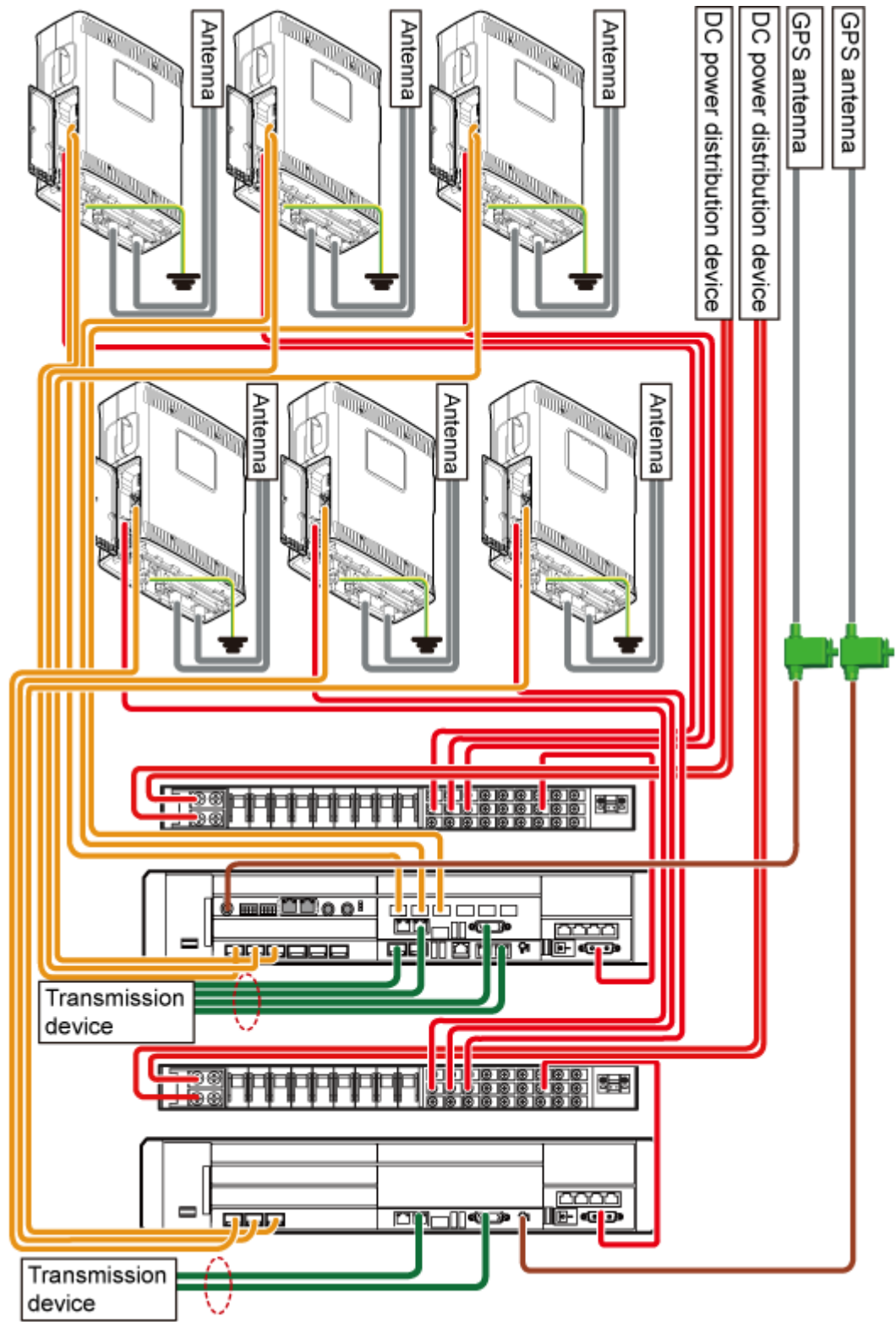



Figure 15-9 Cable connections in the triple-mode scenario (-48 V, three RRU3908s + three RRU3201s)



SRS02C-1001

Table 15-9 lists the cables.

Table 15-9 Cable description

	Power cable		CPRI optical cable		GPS clock signal cable
	Jumper		PGND cable		E1/T1 cable or FE/GE cable

 **NOTE**

The E1/T1 cable or FE/GE cable is used according to on-site requirements. Only an optical cable or Ethernet cable can be connected to a GE port on the LMPT.

15.2.8 Cable Connections (-48 V DC, Three RRU3008s+Three RRU3201s)

This section describes all the cable connections in a base station configured with three RRU3008s and three RRU3201s in the -48 V DC power supply scenario.

Figure 15-10 shows the cable connections.

Figure 15-10 Cable connections (-48 V DC, three RRU3008s+three RRU3201s)

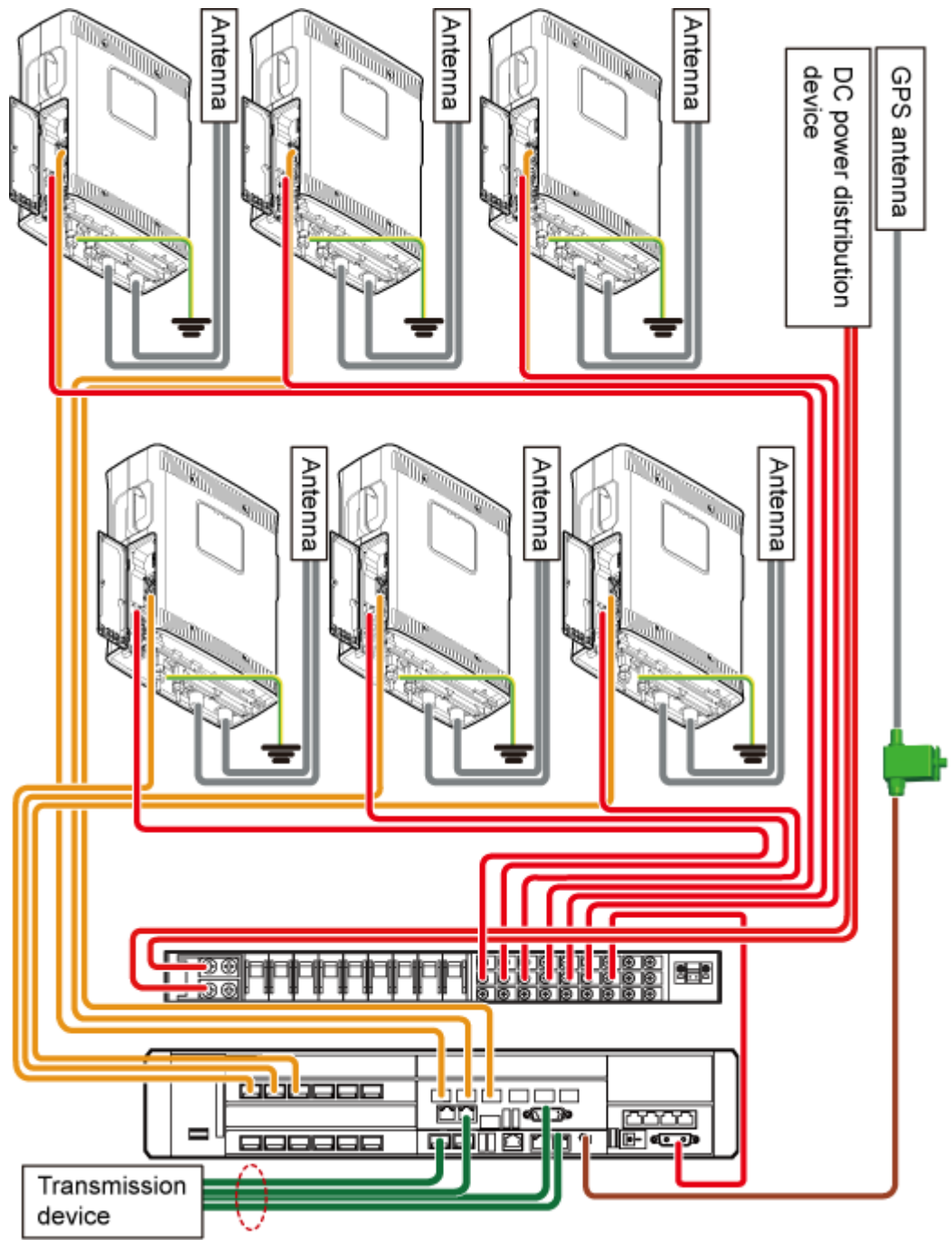



ICD00-LxP4T0-B08

Table 15-10 describes the cables.

Table 15-10 Cable description

	Power cable		CPRI cable		GPS clock signal cable
---	-------------	---	------------	---	------------------------

	Jumper		PGND cable		E1/T1 cable or FE/GE cable
---	--------	---	------------	---	----------------------------------

 **NOTE**

The E1/T1 cable or FE/GE cable is used according to the on-site requirements. Only an optical cable or Ethernet cable can be connected to a GE port on the LMPT.

15.2.9 Cable Connections (-48 V DC, Three RRU3804s+Three RRU3201s)

This section describes all the cable connections in a base station configured with three RRU3804s and three RRU3201s in the -48 V DC power supply scenario.

[Figure 15-11](#) shows the cable connections.

Figure 15-11 Cable connections (-48 V DC, three RRU3804s+three RRU3201s)

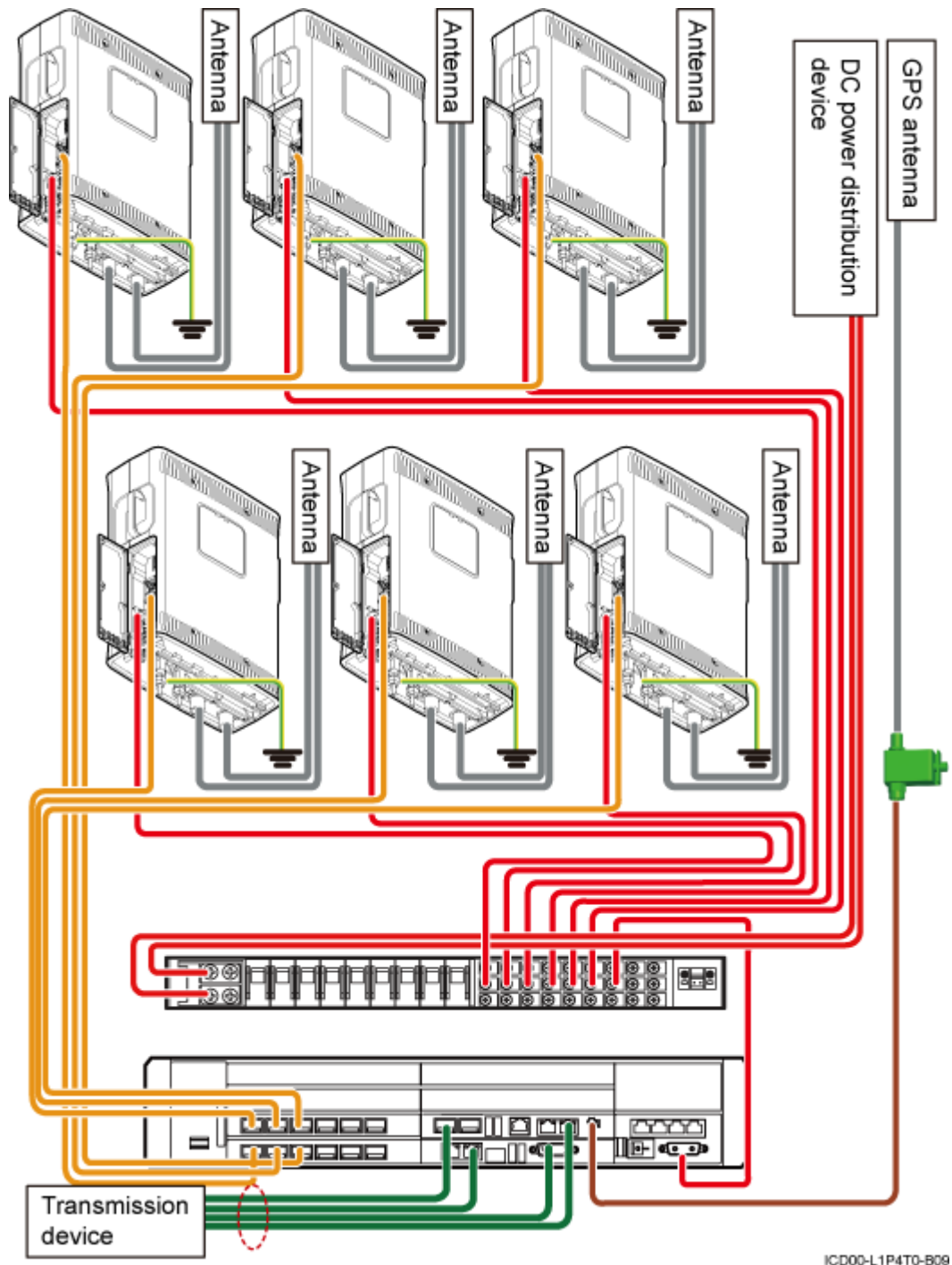



ICD00-L1P4T0-B09

Table 15-11 describes the cables.

Table 15-11 Cable description

	Power cable		CPRI cable		GPS clock signal cable
---	-------------	---	------------	---	------------------------

	Jumper		PGND cable		E1/T1 cable or FE/GE cable
---	--------	---	------------	---	----------------------------------

 **NOTE**

The E1/T1 cable or FE/GE cable is used according to the on-site requirements. Only an optical cable or Ethernet cable can be connected to a GE port on the LMPT.

15.2.10 Cable Connections (-48 V DC, Six RRU3008s+Six RRU3804s)

This section describes all the cable connections in a base station configured with six RRU3008s and six RRU3804s in the -48 V DC power supply scenario.

[Figure 15-12](#) shows the cable connections.



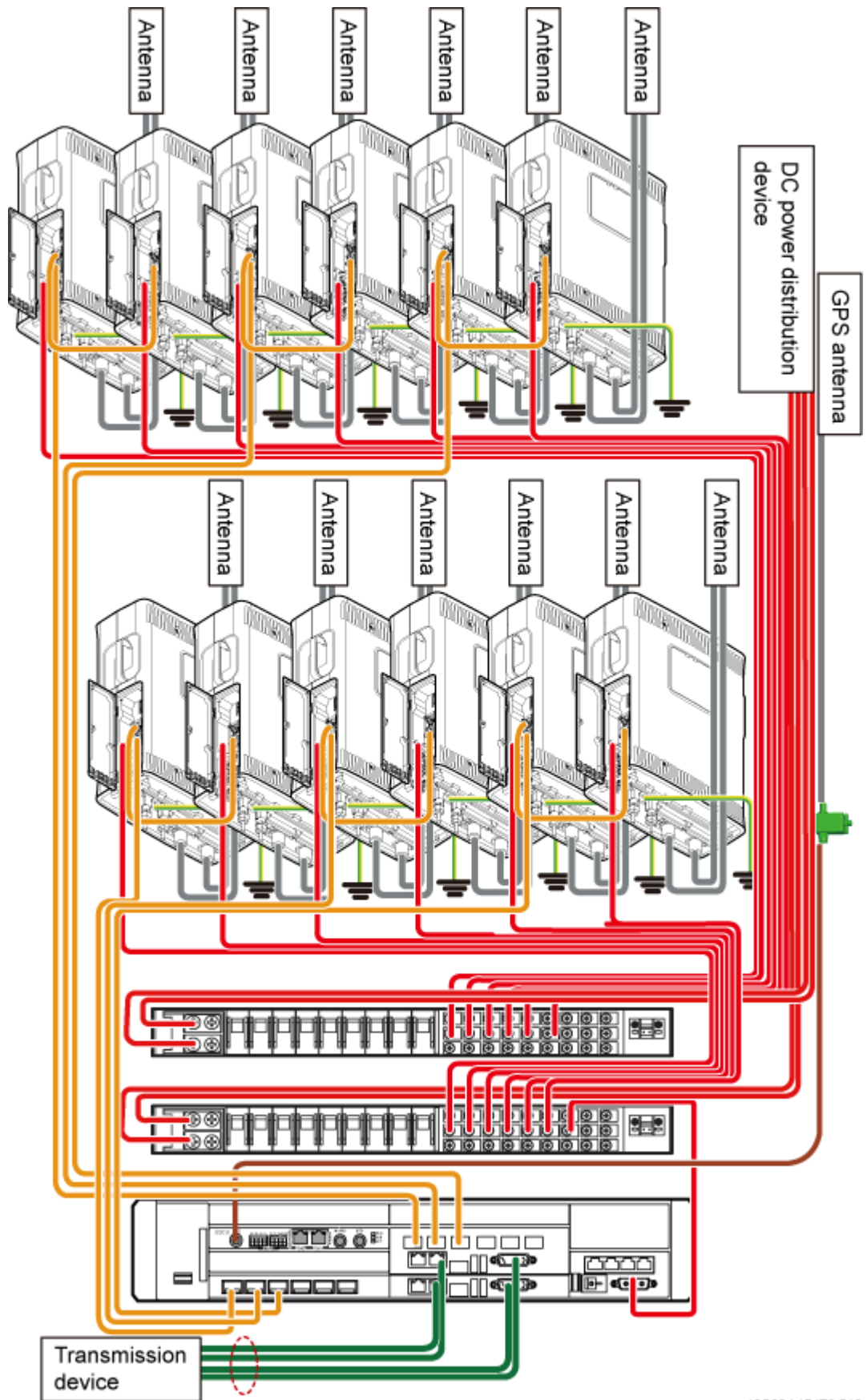



Figure 15-12 Cable connections (-48 V DC, six RRU3008s+six RRU3804s)



ICD00-L1P4T0-B10

Table 15-12 describes the cables.

Table 15-12 Cable description

	Power cable		CPRI cable		GPS clock signal cable
	Jumper		PGND cable		E1/T1 cable or FE/GE cable

 **NOTE**

The E1/T1 cable or FE/GE cable is used according to the on-site requirements.

15.2.11 Cable Connections (-48 V DC, Six RRU3908s+Six RRU3804s)

This section describes all the cable connections in the dual-mode and triple-mode scenarios when six RRU3908s and six RRU3804s are configured and the -48 V DC power supply is provided.

Cable Connections in the Dual-Mode Scenario

Figure 15-13 shows the cable connections in the dual-mode scenario.



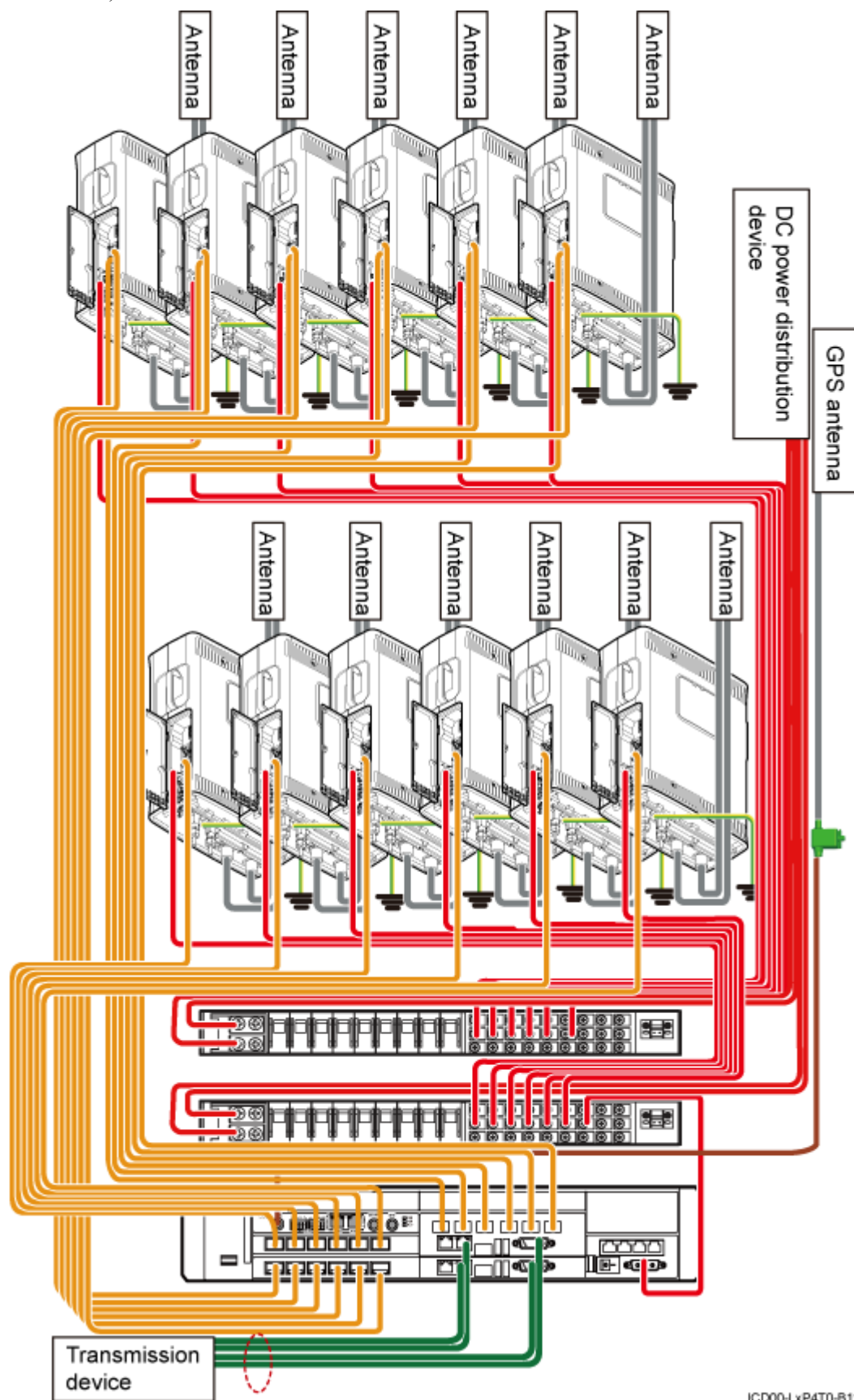



Figure 15-13 Cable connections in the dual-mode scenario (-48 V, six RRU3908s + six RRU3804s)



ICD00-LxP4T0-B11

Table 15-13 lists the cables.

Table 15-13 Cable description

	Power cable		CPRI optical cable		GPS clock signal cable
	Jumper		PGND cable		E1/T1 cable or FE/GE cable

 **NOTE**

The E1/T1 cable or FE/GE cable is used according to on-site requirements.

Cable Connections in the Triple-Mode Scenario

The cable connections in the triple-mode scenario consists of GSM+LTE and UMTS Only cable connections, as shown in [Figure 15-14](#) and [Figure 15-15](#).

Figure 15-14 Cable connections in the GSM+LTE scenario (-48 V, six RRU3908s)

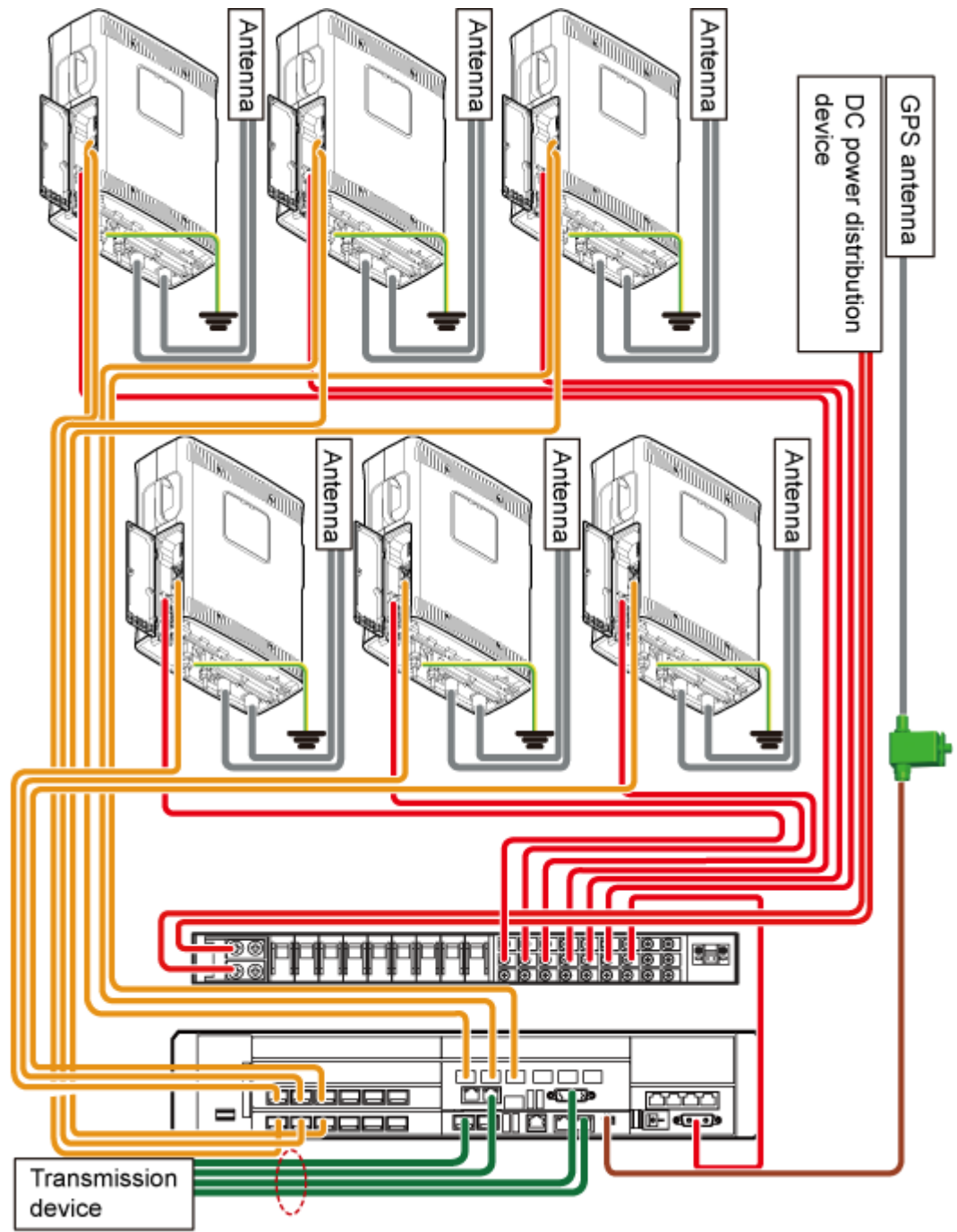



ICD00-L1P4T0-B07

Table 15-14 lists the cables.

Table 15-14 Cable description

	Power cable		CPRI optical cable		GPS clock signal cable
---	-------------	---	--------------------	---	------------------------

	Jumper		PGND cable		E1/T1 cable or FE/GE cable
---	--------	---	------------	---	----------------------------



NOTE

The E1/T1 cable or FE/GE cable is used according to on-site requirements. Only an optical cable or Ethernet cable can be connected to a GE port on the LMPT.



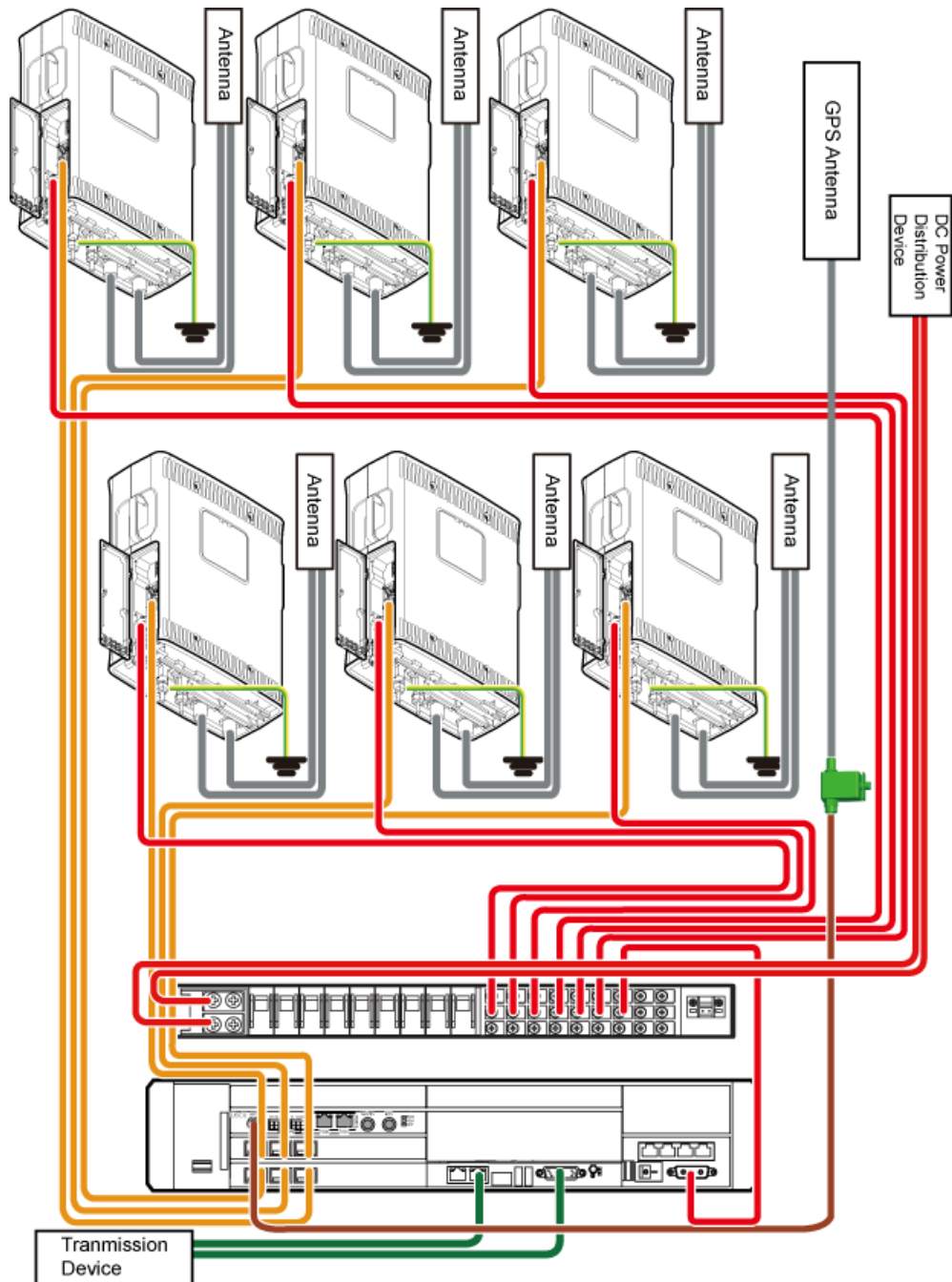



Figure 15-15 Cable connections in the UMTS Only scenario (-48 V, six RRU3804s)



ICD00-L1P4T0-B02

Table 15-15 lists the cables.

Table 15-15 Cable description

	Power cable		CPRI optical cable		GPS clock signal cable
	Jumper		PGND cable		E1/T1 cable or FE/GE cable

 **NOTE**

The E1/T1 cable or FE/GE cable is used according to on-site requirements.

15.2.12 Cable Connections (-48 V DC, Six RRU3908s+Six RRU3201s)

This section describes all the cable connections in the dual-mode and triple-mode scenarios when six RRU3908s and six RRU3201s are configured and the -48 V DC power supply is provided.

Cable Connections in the Dual-Mode Scenario

Figure 15-16 shows the cable connections in the dual-mode scenario.



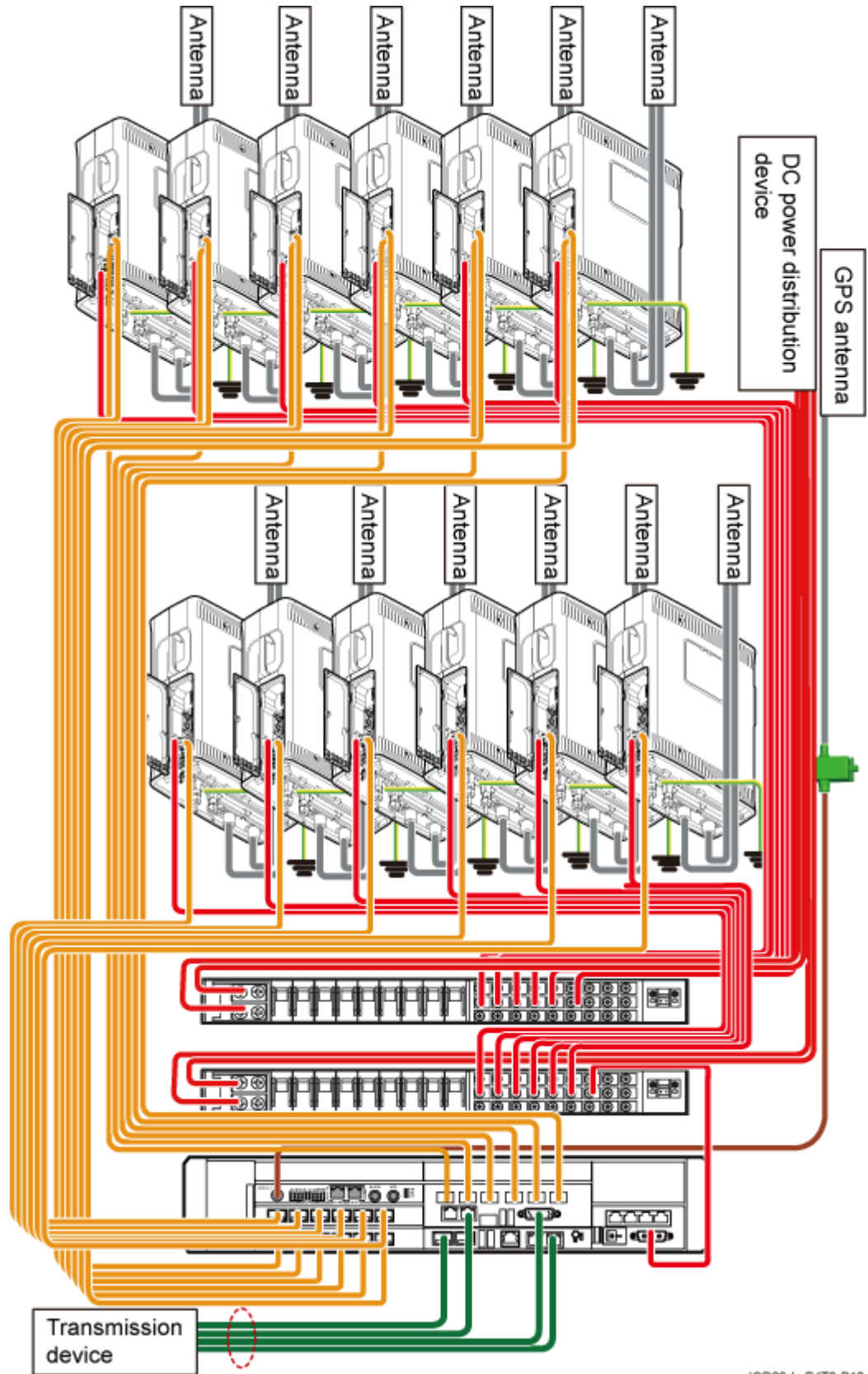



Figure 15-16 Cable connections in the dual-mode scenario (-48 V, six RRU3908s + six RRU3201s)



ICD00-LxP4T0-B12

Table 15-16 lists the cables.

Table 15-16 Cable description

	Power cable		CPRI optical cable		GPS clock signal cable
	Jumper		PGND cable		E1/T1 cable or FE/GE cable

 **NOTE**

The E1/T1 cable or FE/GE cable is used according to on-site requirements. Only an optical cable or Ethernet cable can be connected to a GE port on the LMPT.

Cable Connections in the Triple-Mode Scenario

The cable connections in the triple-mode scenario consists of GSM+UMTS and LTE Only cable connections, as shown in [Figure 15-17](#) and [Figure 15-18](#).

Figure 15-17 Cable connections in the GSM+UMTS Only scenario (-48 V DC, six RRU3908s)

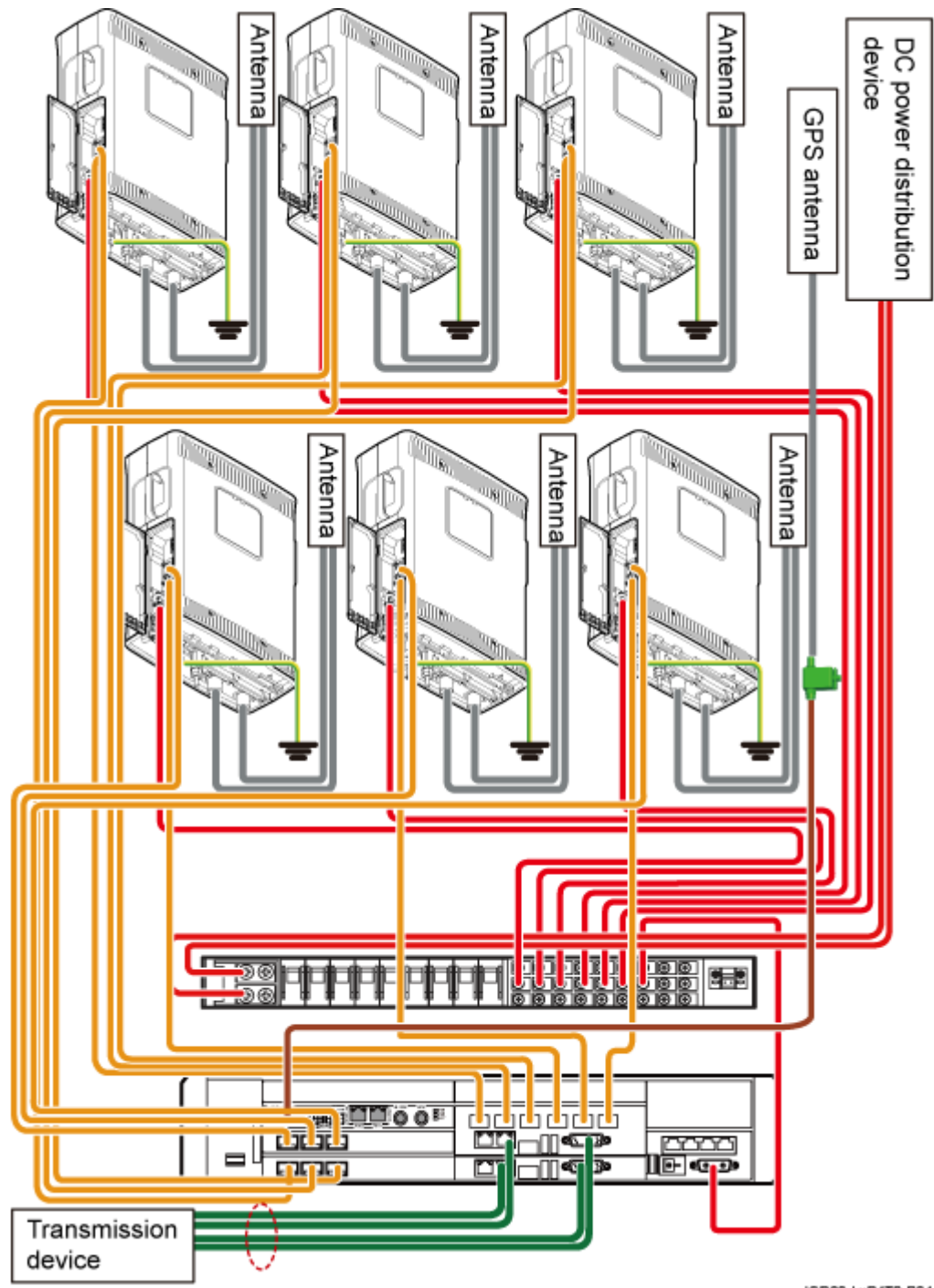



ICD00-LxP4T0-B04

Table 15-17 lists the cables.

Table 15-17 Cable description

	Power cable		CPRI optical cable		GPS clock signal cable
---	-------------	---	--------------------	---	------------------------

	Jumper		PGND cable		E1/T1 cable or FE/GE cable
---	--------	---	------------	---	----------------------------------

 **NOTE**

The E1/T1 cable or FE/GE cable is used according to on-site requirements.

Figure 15-18 Cable connections in the LTE Only scenario (-48 V DC, six RRU3201s)

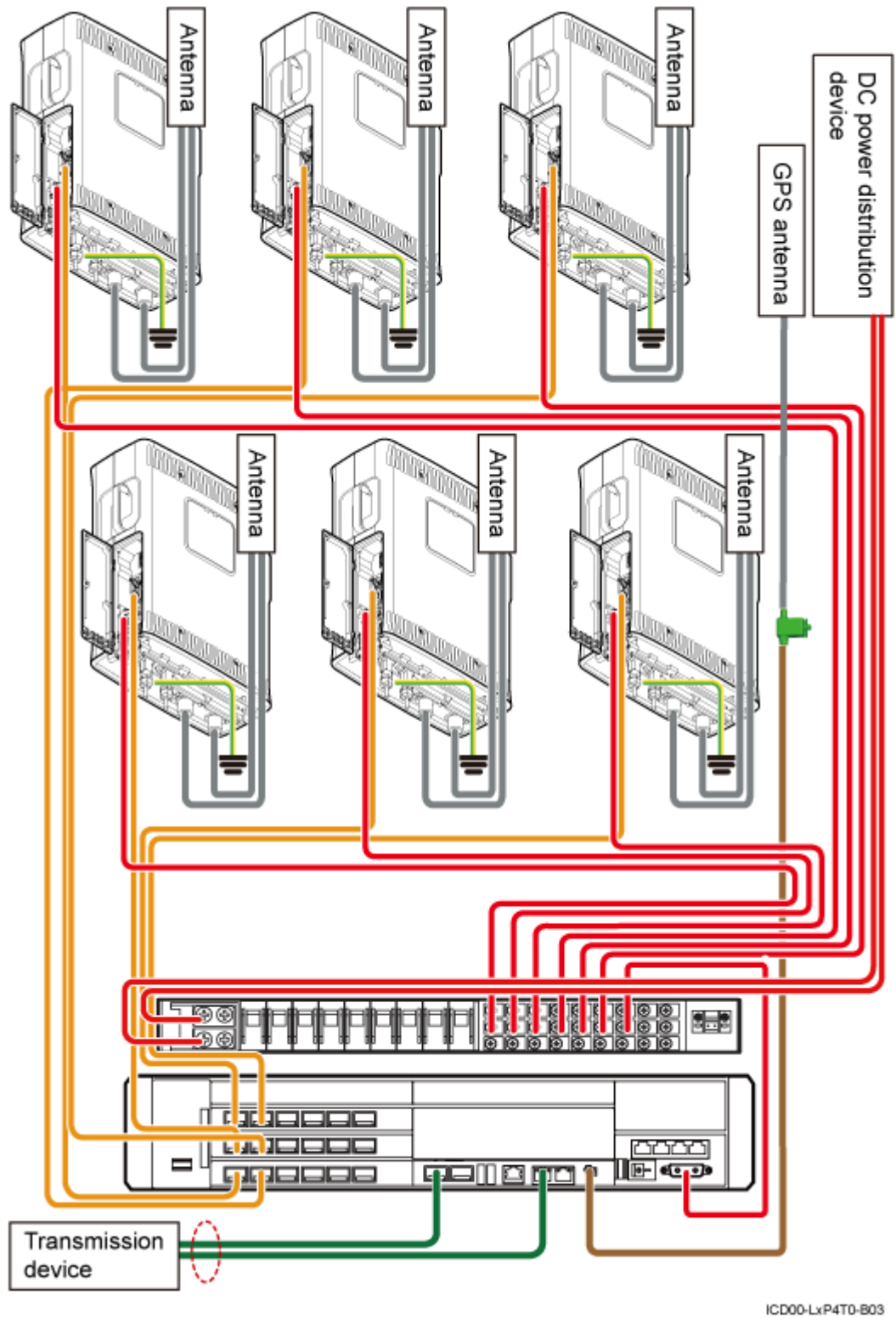







Table 15-18 lists the cables.

Table 15-18 Cable description

	Power cable		CPRI optical cable		GPS clock signal cable
	Jumper		PGND cable		E1/T1 cable or FE/GE cable



NOTE

Only an optical cable or Ethernet cable can be connected to a GE port on the LMPT.

15.2.13 Cable Connections (-48 V DC, Six RRU3008s+Six RRU3201s)

This section describes all the cable connections in a base station configured with six RRU3008s and six RRU3201s in the -48 V DC power supply scenario.

Figure 15-19 shows the cable connections.

Figure 15-19 Cable connections (-48 V DC, six RRU3008s+six RRU3201s)

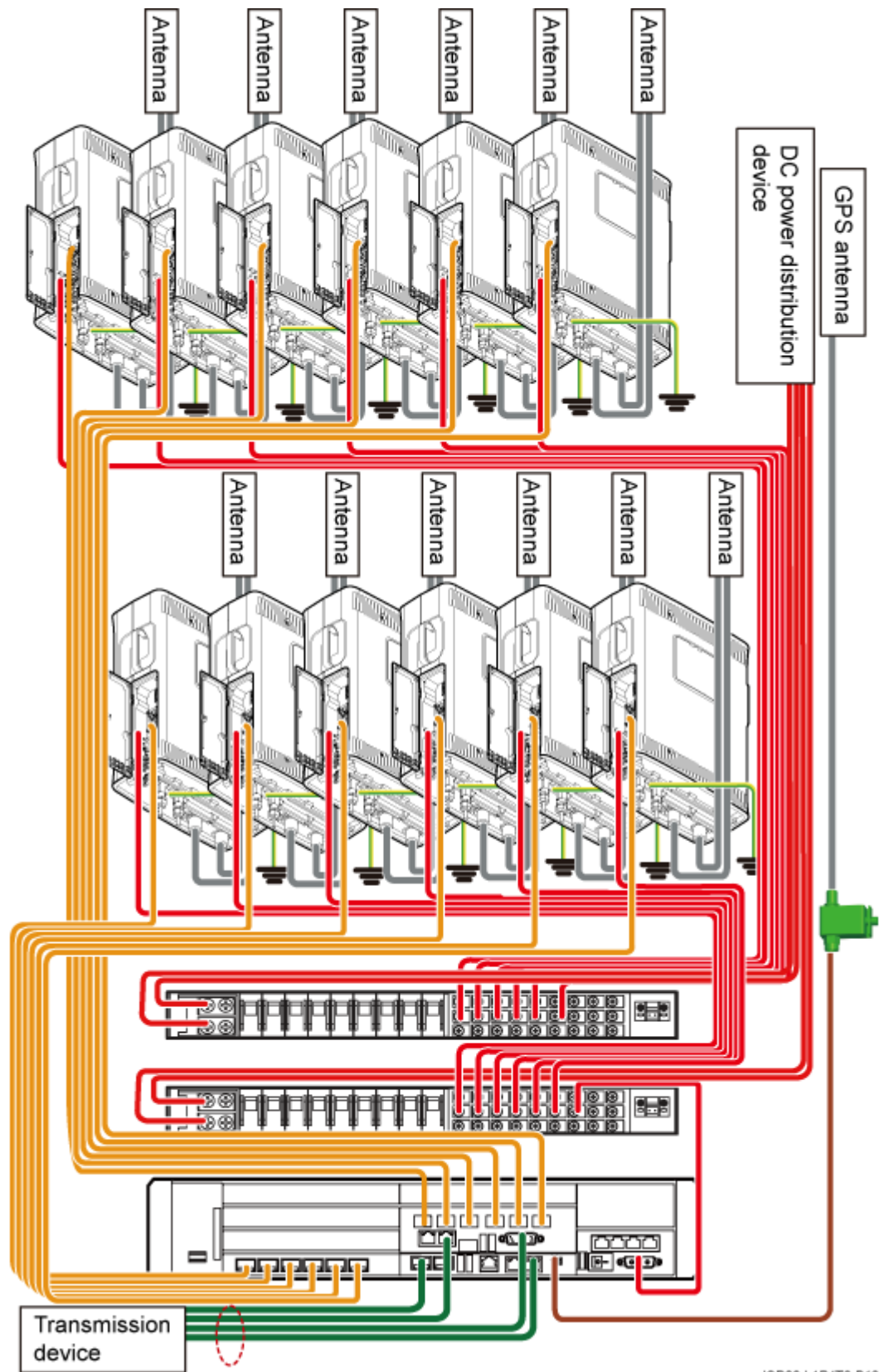







Table 15-19 describes the cables.

Table 15-19 Cable description

	Power cable		CPRI cable		GPS clock signal cable
	Jumper		PGND cable		E1/T1 cable or FE/GE cable



NOTE

The E1/T1 cable or FE/GE cable is used according to the on-site requirements. Only an optical cable or Ethernet cable can be connected to a GE port on the LMPT.

15.2.14 Cable Connections (-48 V DC, Six RRU3804s+Six RRU3201s)

This section describes all the cable connections in a base station configured with six RRU3804s and six RRU3201s in the -48 V DC power supply scenario.

Figure 15-20 shows the cable connections.

Figure 15-20 Cable connections (-48 V DC, six RRU3804s+six RRU3201s)

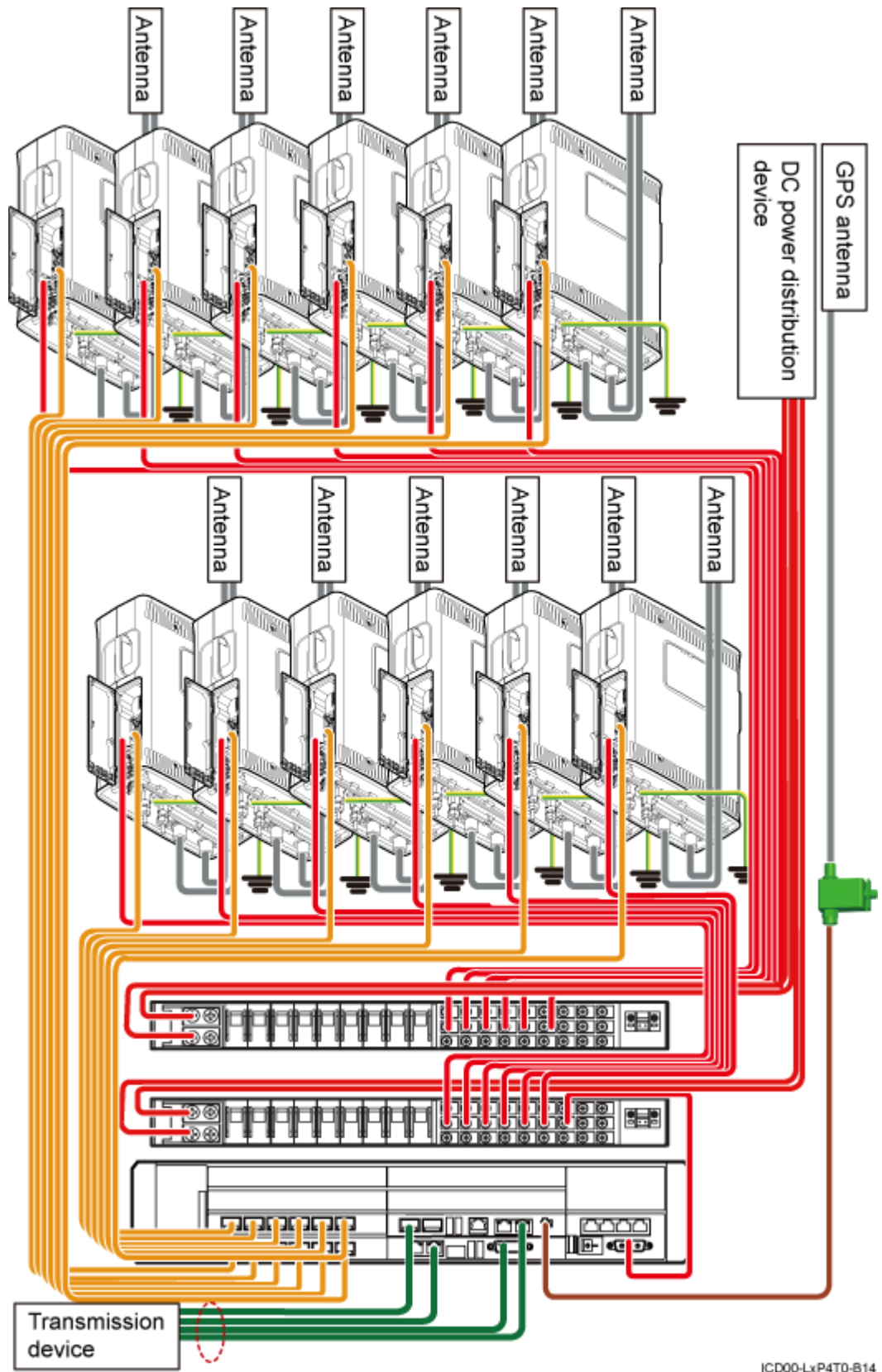







Table 15-20 describes the cables.

Table 15-20 Cable description

	Power cable		CPRI cable		GPS clock signal cable
	Jumper		PGND cable		E1/T1 cable or FE/GE cable



NOTE

The E1/T1 cable or FE/GE cable is used according to the on-site requirements. Only an optical cable or Ethernet cable can be connected to a GE port on the LMPT.

15.2.15 Cable Connections (AC RRU)

This section describes all the cable connections for the only one RRU configured in a base station with AC power supply.

Figure 15-21 shows the cable connections.

Figure 15-21 Cable connections (AC RRU)

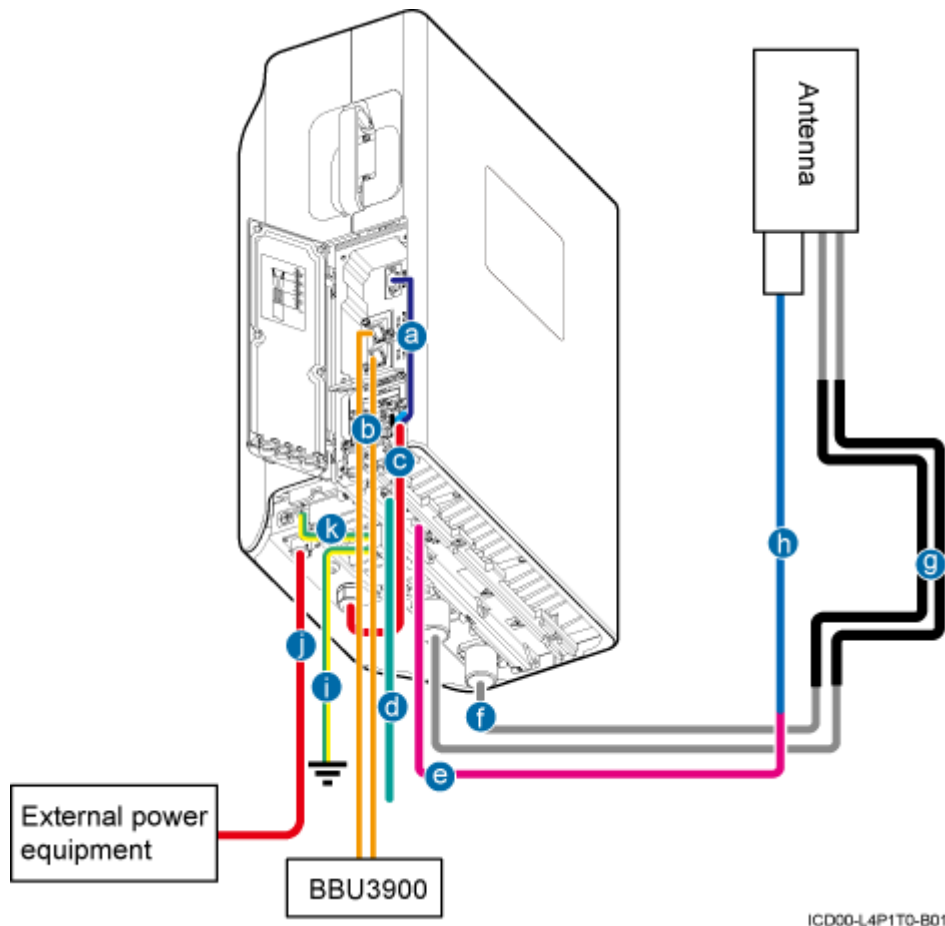

Table 15-21 describes the cables.

Table 15-21 Cable description

SN	Cable
a	Monitoring signal cable for the AC RRU
b	CPRI optical cable
c	Power cable for the DC RRU
d	Inter-RRU RF signal cable
e	AISG multi-wire cable for the RRU
f	RF jumper for the RRU
g	Feeder
h	Extended AISG cable for the RRU
i	PGND cable
j	Power cable for the AC RRU
k	Equipotential cable

15.2.16 Cable Connections (220 V AC)

This section describes the cable connections for the power equipment (AC/DC) in a base station with 220 V AC power supply.

 **NOTE**

The cable connections for the RRUs in the 220 V AC and -48 V DC power supply scenarios are the same. For details, see [15.2 Cable Connections](#).

[Figure 15-22](#) shows the cable connections.

Figure 15-22 Cable connections (220 V AC)

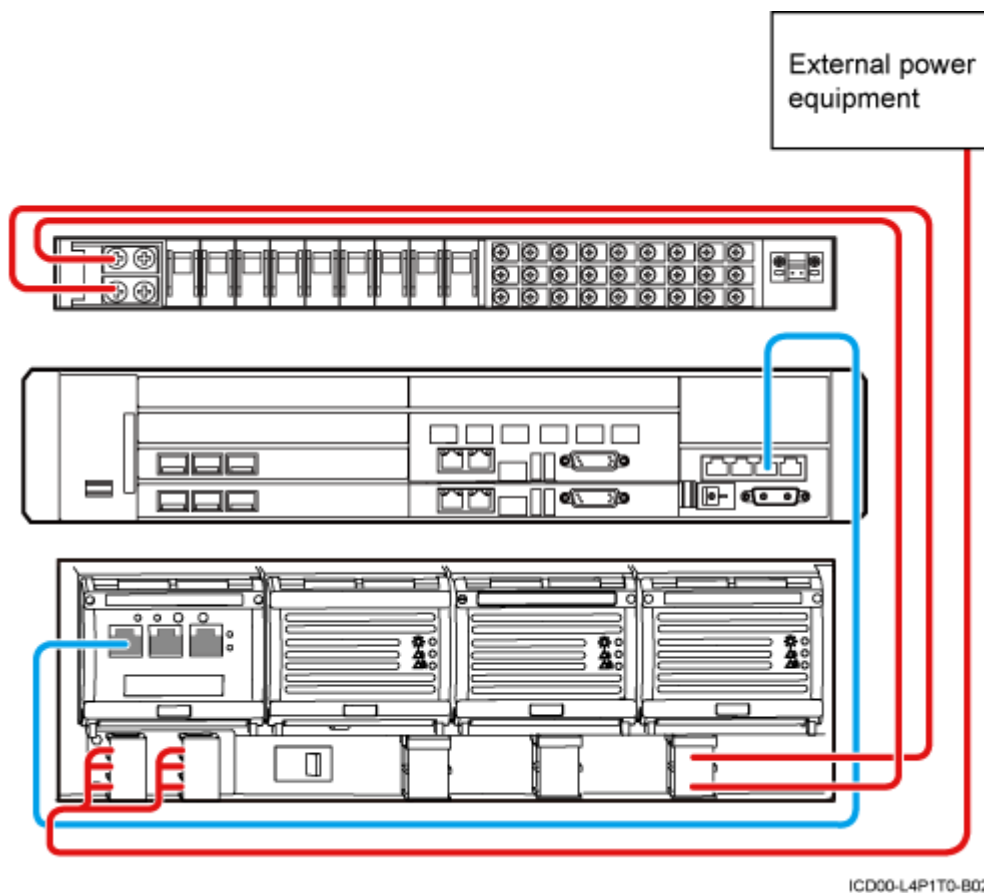

15.2.17 Cable Connections (+24 V DC)

This section describes the cable connections for the power equipment (DC/DC) in a base station with +24 V DC power supply.

NOTE

The cable connections for the RRUs in the +24 V DC and -48 V DC power supply scenarios are the same. For details, see [15.2 Cable Connections](#).

[Figure 15-23](#) shows the cable connections.

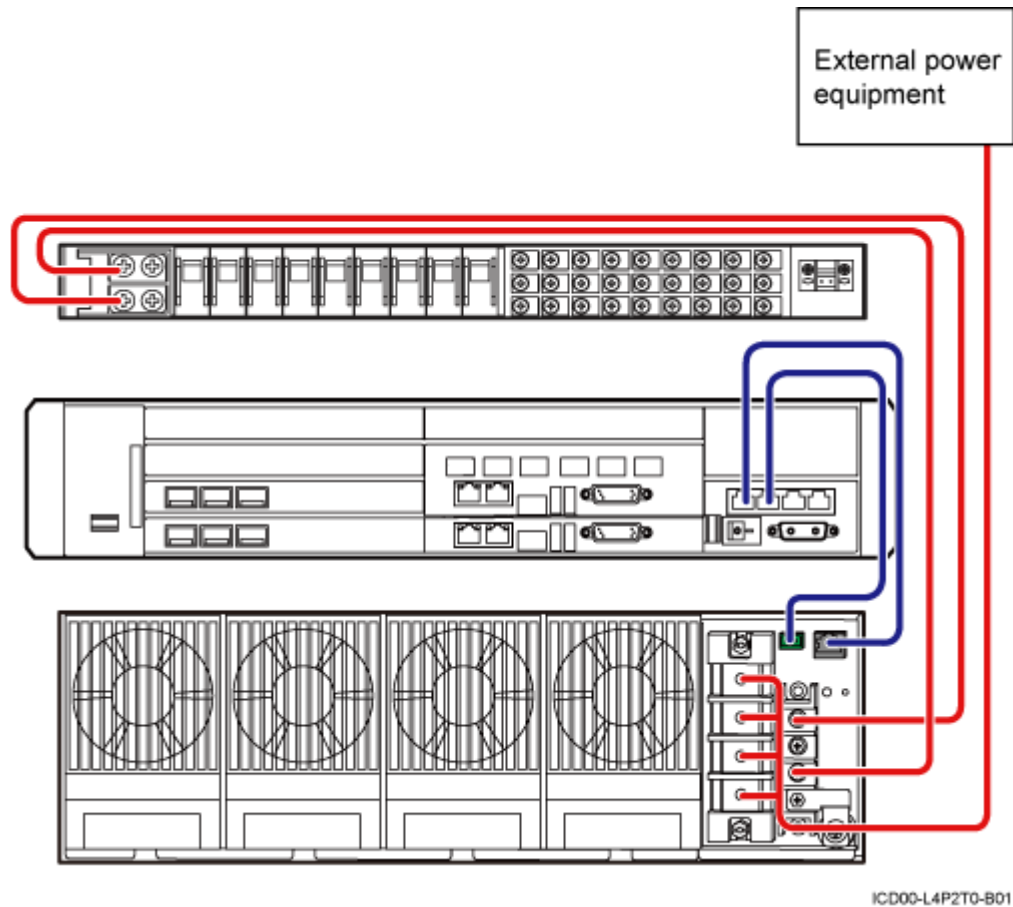
Figure 15-23 Cable connections (+24 V DC)

15.3 Cable Installation Process

This section describes the process of installing the ICR-related cables.

Process of Installing the ICR-Related Cables

Figure 15-24 shows the cable installation process.

Figure 15-24 Process of installing the ICR-related cables

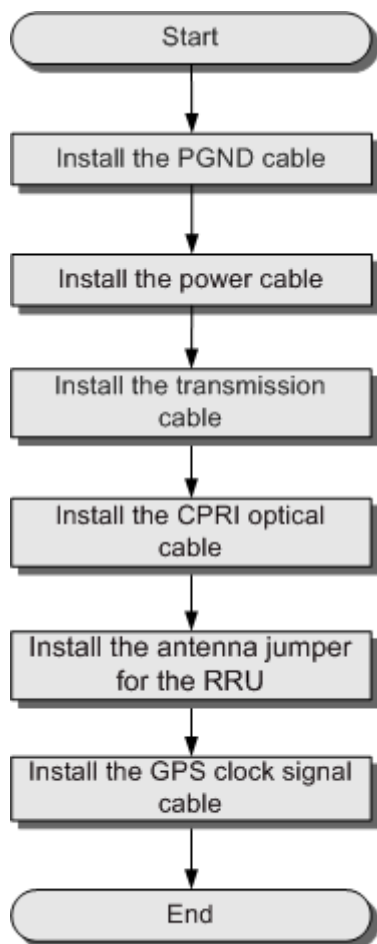

PID00-L0P0TO-L01

15.4 Cable Routes

This section describes the cable routes.

Figure 15-25 shows the plan view of the cable rack. By studying the figure, you can know the cable routes.

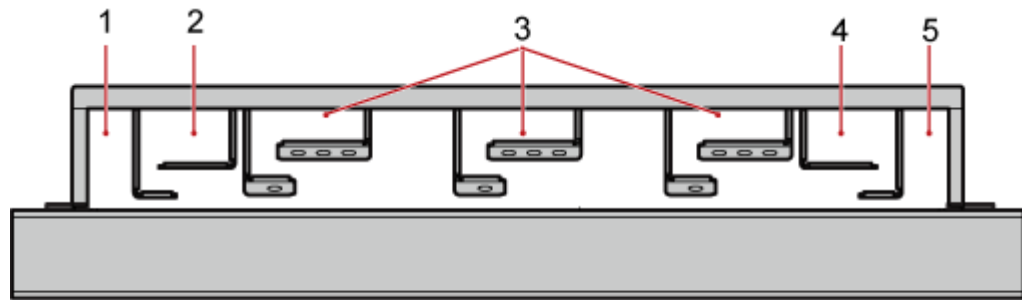
Figure 15-25 Cable routes

ICD00-LxP0T0-B01

- (1) -48 V DC or 220 V AC input power cable (2) Optical cable and PGND cable for the RRU in the (3) Feeder lower part
- (4) Power cable for the RRU and E1 cable (5) +24 V DC input power cable -

15.5 Installing the PGND Cable for the RRU

This section describes the procedure for installing the PGND cable for the RRU.

Context

The cross-section area of the PGND cable for the RRU is 16 mm².

Procedure

- Installing the PGND cable for the DC RRU
 1. Prepare the PGND cable.
 - (1) Cut the cables to proper lengths based on the actual cable route.
 - (2) Add OT terminals to both ends of the cable.
 2. Connect one end of the PGND cable to the RRU.
 3. Connect the other end to the ground bar on the IFS06.

NOTE

When installing the PGND cable, keep the crimping tube of the OT terminal in the correct direction.

Figure 15-26 Connections of the PGND cables for the DC RRU

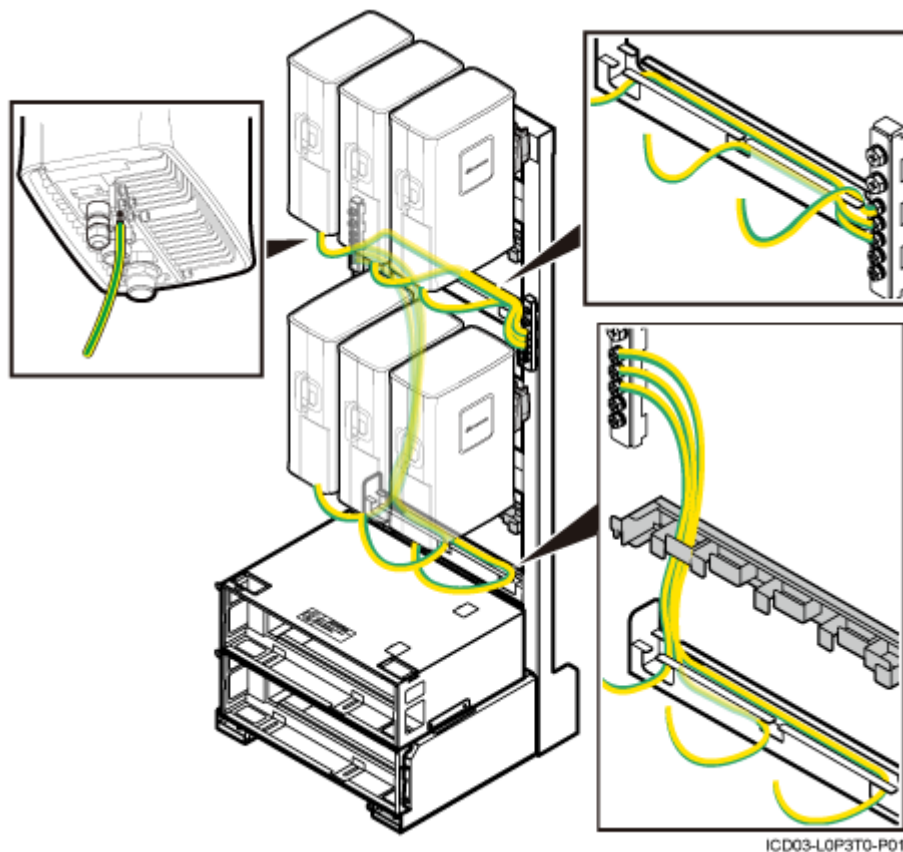

4. Route cables by referring to [15.1 Cabling Requirements](#).
 5. Use cable ties to bind cables.
 6. Label the installed cables by referring to Attaching a Sign Plate Label.
- Installing the PGND cable for the AC RRU
 1. Prepare the PGND cable.
 - (1) Cut the cables to proper lengths based on the actual cable route.
 - (2) Add OT terminals to both ends of the cable.
 2. Connect one end of the PGND cable to the RRU.
 3. Connect the other end to the ground bar on the IFS06.

NOTE

When installing the PGND cable, keep the crimping tube of the OT terminal in the correct direction.

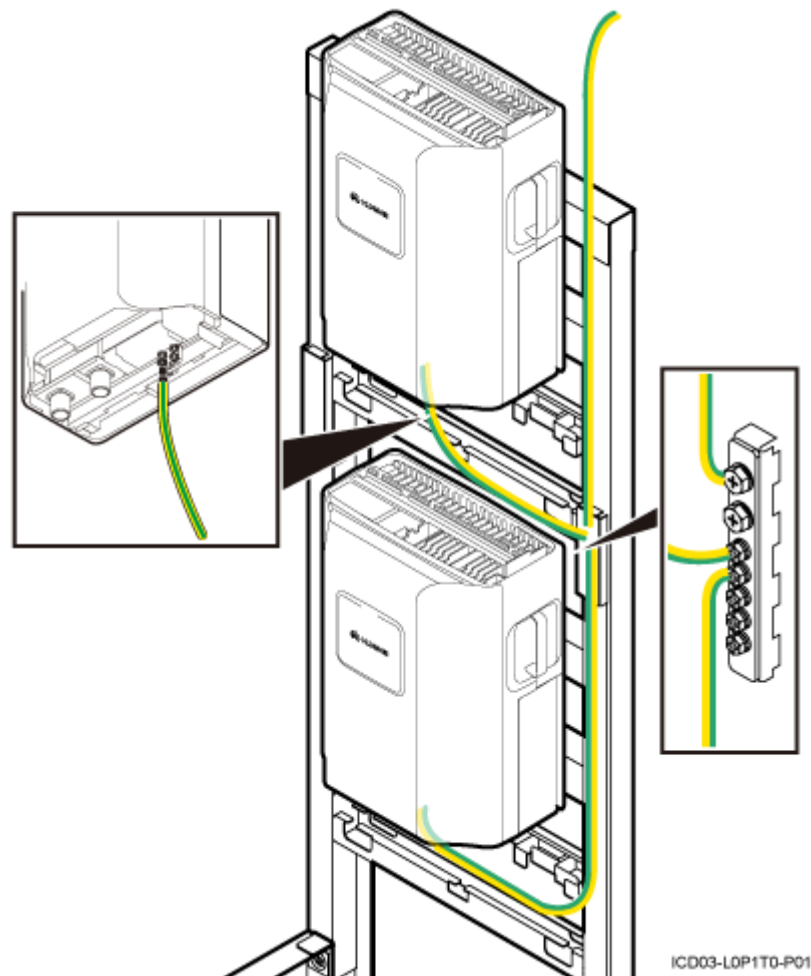
Figure 15-27 Connections of the PGND cables for the AC RRU

4. Route cables by referring to [15.1 Cabling Requirements](#).
5. Use cable ties to bind cables.
6. Label the installed cables by referring to Attaching a Sign Plate Label.

----End

15.6 Installing the Power Cable for the BBU

This section describes the installation of the power cable for the BBU.

Context

The cross-section area of the power cable for the BBU is 1.5 mm².

Procedure

- Step 1** Add an OT terminal to the power cable for the BBU. For details, see Assembling the OT Terminal and the Power Cable.



NOTE

The 3V3 power connector is added to the power cable for the BBU before delivery, and you must add OT terminals at the other end.

Step 2 Install the power cable for the BBU, as shown in [Figure 15-28](#).

1. Link the 3V3 power connector at one end of the power cable for the BBU to the PWR port on the UPEU in the BBU, and then tighten the screws on the connector until the tightening torque reaches 0.25 N·m.
2. Link the OT terminals on the blue and black wires at the other end to the wiring terminals labeled NEG(-) and RTN(+) near the LOAD6 label on the DCDU-03B respectively.

Figure 15-28 Installing the power cable for the BBU

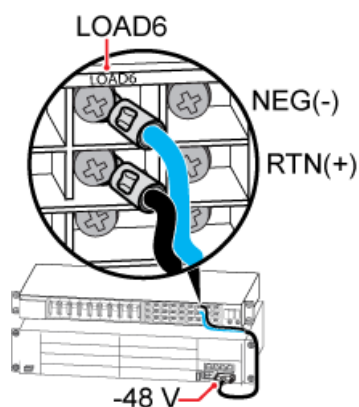

Step 3 Route cables by referring to [15.1 Cabling Requirements](#).

Step 4 Use cable ties to bind cables.

Step 5 Label the installed cables by referring to Attaching an L-Shaped Label.

---End

15.7 Installing the Input Power Cable

This section describes the installation of the input power cable.

Context

You must select the corresponding procedure according to the types of input power cable, which are -48 V DC, +24 V DC, and 220 V AC input power cables.

The cross-section area of the input power cable is as follows:

- 16 mm² for -48 V DC.
- 25 mm² for +24 V DC.
- 6 mm² for 220 V AC three-phase.
- 2.5 mm² for 220 V AC single-phase.

Procedure

- Installing the -48 V DC input power cable
 1. Prepare the power cable.
 - (1) Cut the cable to the required length based on the actual cable route.
 - (2) Add OT terminals to both ends of the cable.
 2. Connect one end of the power cable to the wiring terminals labeled **RTN(+)** and **NEG (-)** on the DCDU-03B, as shown in 2 of [Figure 15-29](#).
 3. Connect the other end of the cable to the external power equipment after routing the cable along the cable trough at the left-back of the IFS06, as shown in 1 of [Figure 15-29](#).
 4. Route cables by referring to [15.1 Cabling Requirements](#).
 5. Use cable ties to bind cables.
 6. Label the installed cables by referring to Attaching an L-Shaped Label.
- Installing the +24 V DC input power cable
 1. Prepare the power cable.
 - (1) Cut the cable to the required length based on the actual cable route.
 - (2) Add OT terminals to both ends of the cable.
 2. Connect one end of the power cable to the wiring terminals labeled + and - on the power equipment (DC/DC), as shown in 6 of [Figure 15-29](#).
 3. Connect the other end of the cable to the external power equipment after routing the cable along the cable trough at the left-back of the IFS06, as shown in 1 of [Figure 15-29](#).
 4. Route cables by referring to [15.1 Cabling Requirements](#).
 5. Use cable ties to bind cables.
 6. Label the installed cables by referring to Attaching an L-Shaped Label.
- Installing the 220 V AC input power cable
 1. Prepare the power cable.
 - (1) Cut the cable to the required length based on the actual cable route.
 - (2) Add OT terminals to both ends of the cable.
 2. Connect one end of the power cable to the port labeled **RS232/RS485** on the power equipment (AC/DC), as shown in 5 of [Figure 15-29](#).
 - For details about the connections of the 220 V AC single-phase input power cable, see 3 in [Figure 15-29](#).
 - For details about the connections of the 220 V AC three-phase input power cable, see 4 in [Figure 15-29](#).
 3. Connect the other end of the cable to the external power equipment after routing the cable along the cable trough at the left-back of the IFS06, as shown in 1 of [Figure 15-29](#).
 4. Route cables by referring to [15.1 Cabling Requirements](#).
 5. Use cable ties to bind cables.
 6. Label the installed cables by referring to Attaching a Sign Plate Label.

Figure 15-29 Installing the input power cable

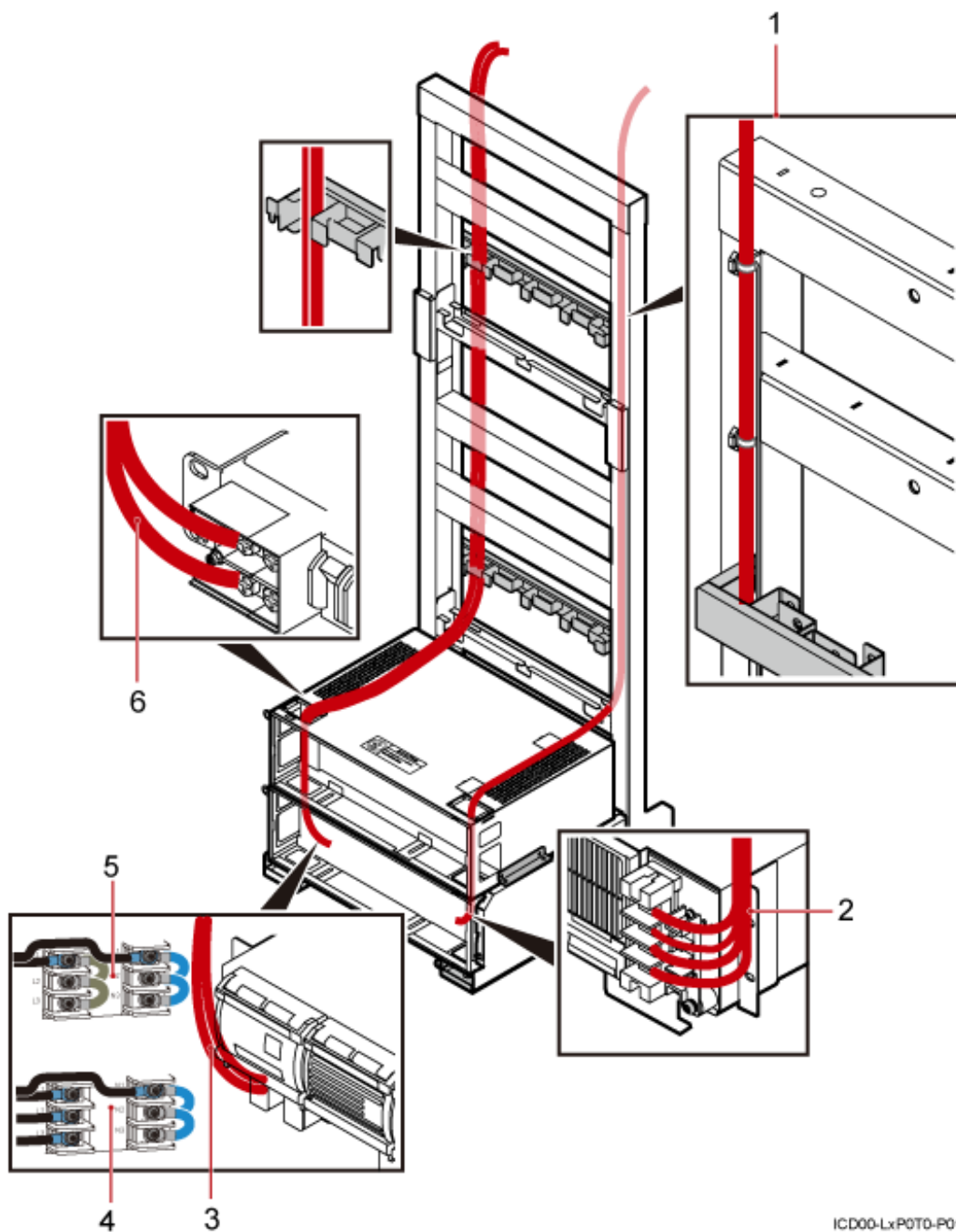

IC.D00-Lx.P0T0-P01

- | | | |
|---|---|--|
| (1) Back view | (2) Input power cable for the DCDU | (3) Connections of the 220 V AC single-phase input power cable |
| (4) Connections of the 220 V AC three-phase input power cable | (5) Input power cable for the power equipment (AC/DC) | (6) Input power cable for the power equipment (DC/DC) |

---End

15.8 (Optional) Installing the Power Cable and Monitoring Signal Cable for the DCDU

This section describes the procedure for installing the power cable and monitoring signal cable.

Context

The cross-section area of the power cable for the DCDU is 25 mm².

In the 220 V AC and +24 V DC power supply scenario, the power cable needs to be installed between the power equipment and the DCDU, and the monitoring signal cable needs to be installed between the power equipment and the BBU.

NOTE

In the -48 V DC power supply scenario, the power cable is connected to the DCDU directly, and the monitoring signal cable is connected to the BBU directly.

Procedure

- Installing the power cable and monitoring signal cable for the DCDU in the +24 V DC power supply scenario
 1. Prepare the power cable.
 - (1) Cut the cable to the required length based on the actual cable route.
 - (2) Add OT terminals to both ends of the cable.
 2. Connect one end of the power cable to the wiring terminals labeled **LOAD(-)** and **RTN(+)** on the power equipment (DC/DC).
 3. Connect the other end to the wiring terminals labeled **NEG(-)** and **RTN(+)** on the DCDU.
 4. Connect one end of the monitoring signal cable for the PSU to the **ALM0** port on the UPEU.
 5. Connect the other end to the **ALM** port on the power equipment (DC/DC).
 6. Connect one end of the in-position signal cable for the PSU to the **ALM1** port on the UPEU.
 7. Connect the other end to the **PRESENT** port on the power equipment (DC/DC).

The red cable in [Figure 15-30](#) is the power cable, and the blue cable is the monitoring signal cable.

Figure 15-30 Installing the power cable and monitoring signal cable (+24 V DC)

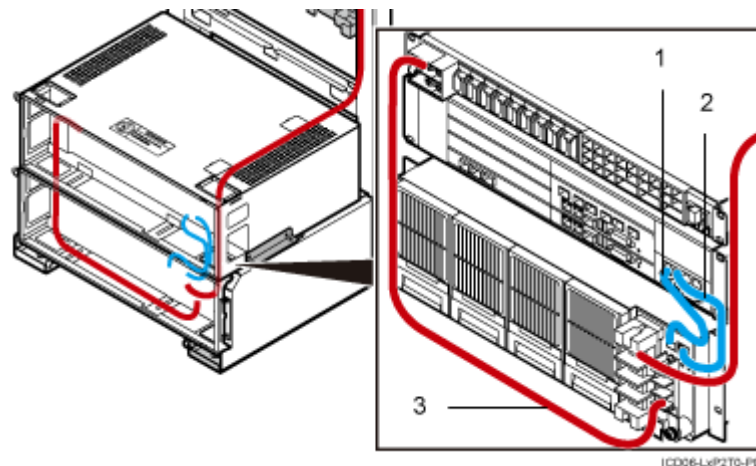

(1) In-position signal cable for the PSU (2) Monitoring signal cable for the PSU (3) Power cable for the DCDU

8. Route cables by referring to **15.1 Cabling Requirements**.
 9. Use cable ties to bind cables.
 10. Label the installed cables by referring to Attaching an L-Shaped Label.
- Installing the power cable and monitoring signal cable for the DCDU in the 220 V AC power supply scenario
 1. Prepare the power cable.
 - (1) Cut the cable to the required length based on the actual cable route.
 - (2) Add OT terminals to both ends of the cable.
 2. Connect one end of the power cable to the wiring terminals labeled **LOAD1(-)/LOAD2(-)** and **RTN(+)** on the power equipment (AC/DC).
 3. Connect the other end to the wiring terminals labeled **NEG(-)** and **RTN(+)** on the DCDU.
 4. Connect one end of the monitoring signal cable to the **MON0** port on the UPEU.
 5. Connect the other end to the **RS232/RS485** port on the power equipment (AC/DC).

The red cable in **Figure 15-31** is the power cable, and the blue cable is the monitoring signal cable.

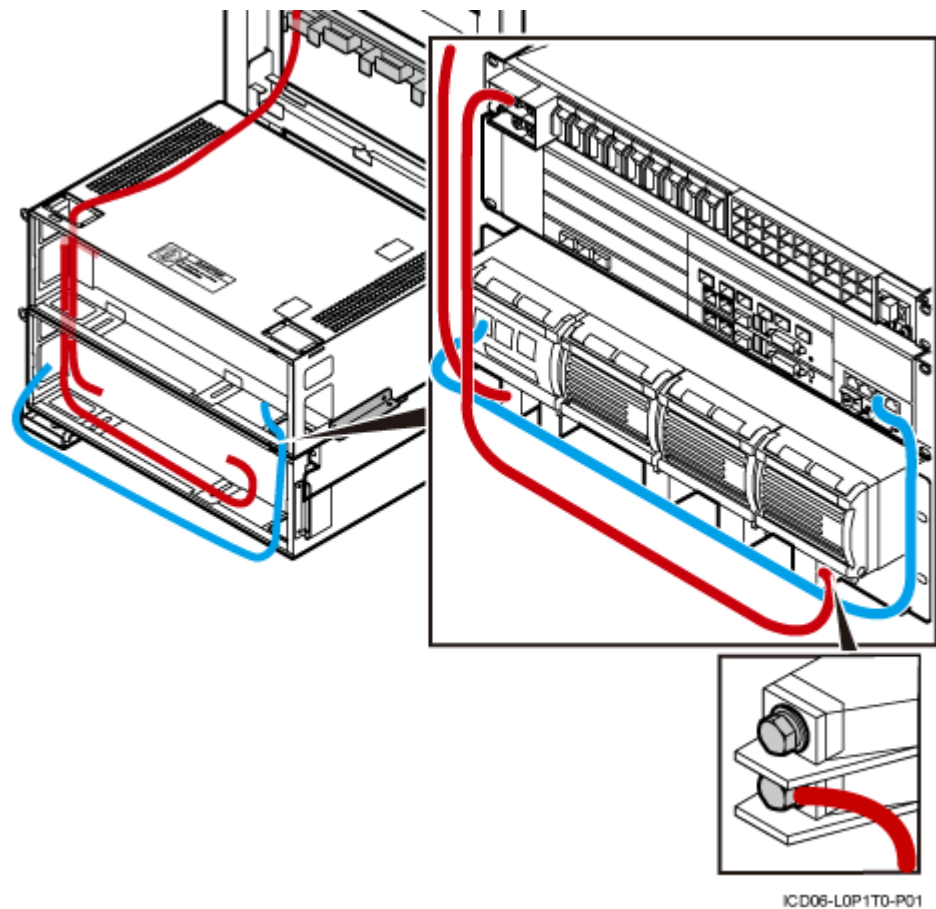
Figure 15-31 Installing the power cable and monitoring signal cable (220 V AC)

6. Route cables by referring to [15.1 Cabling Requirements](#).
7. Use cable ties to bind cables.
8. Label the installed cables by referring to Attaching an L-Shaped Label.

---End

15.9 Installing the Power Cable for the RRU

This section describes the installation of the power cable for the RRU.

Context

- The cross-section area of the power cable for the DC RRU is 3.3 mm², which complies with the North American standard.
- The cross-section area of the power cable for the DC RRU is 4 mm², which complies with the European standard.

Procedure

- Installing the power cable for the DC RRU
 1. Prepare the power cable.
 - (1) Cut the cable to the required length based on the actual cable route.

- (2) Add OT terminals to both ends of the cable.
2. Link the OT terminal of the blue power cable for the DC RRU to the **NEG(-)0** port in the cabling cavity of the RRU.
3. Link the OT terminal of the black cable to the **RTN(+)**0**** port.
4. Connect the other end of the power cable for the DC RRU to the **LOAD0** to **LOAD5** port on the DCDU.



CAUTION

The OT terminals are linked differently for different types of RRU. For details, see [Figure 15-32](#).

Figure 15-32 Connections of the power cable for the DC RRU

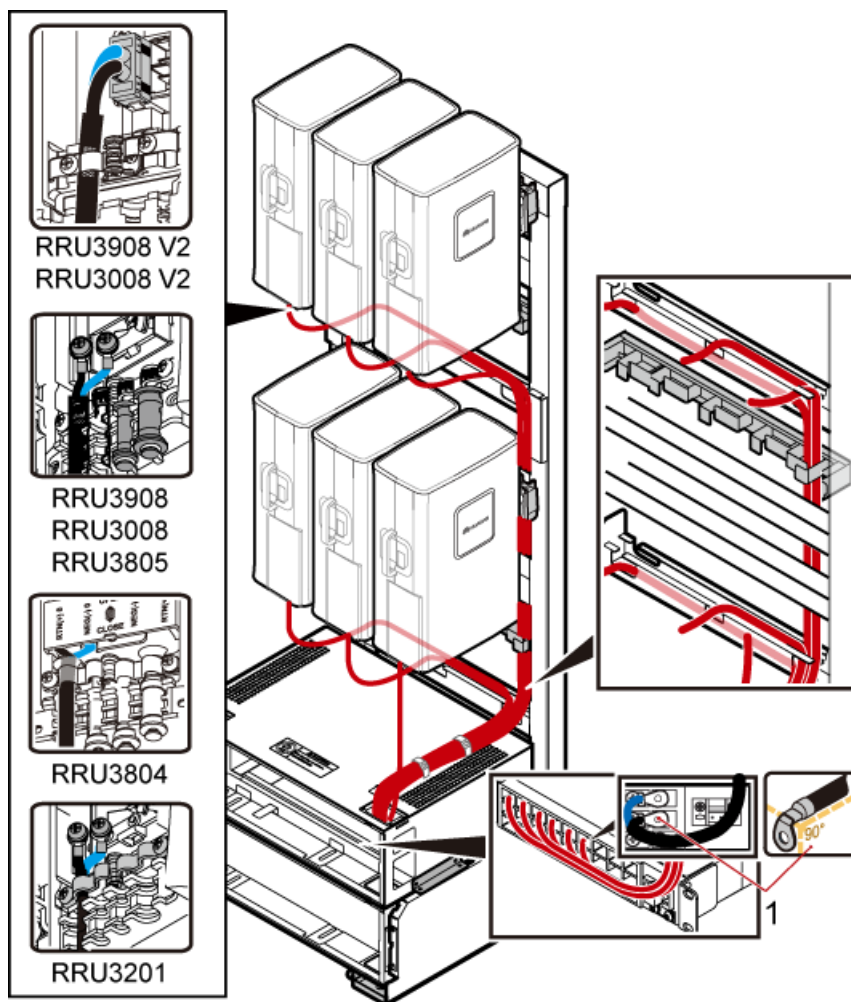

ICD03-LxP3T0-P01

(1) OT terminals bent by 90°

TIP

It is recommended that the OT terminals on the power cable for the RRU be installed on the DCDU in the sequence from right to left.

5. Route cables by referring to [15.1 Cabling Requirements](#).
6. Use cable ties to bind cables.

**CAUTION**

When routing the power cable for the RRU on the top of the IMB03, ensure that the holes for heat dissipation are not covered.

7. Label the installed cables by referring to Attaching a Sign Plate Label.
- Installing the power cable for the AC RRU
 1. Connect one end of the input power cable to the **AC IN** port at the bottom of the AC RRU.
 2. Connect the other end to the external power equipment.

[Figure 15-33](#) shows the cable route.

Figure 15-33 Connections of the power cable for the AC RRU

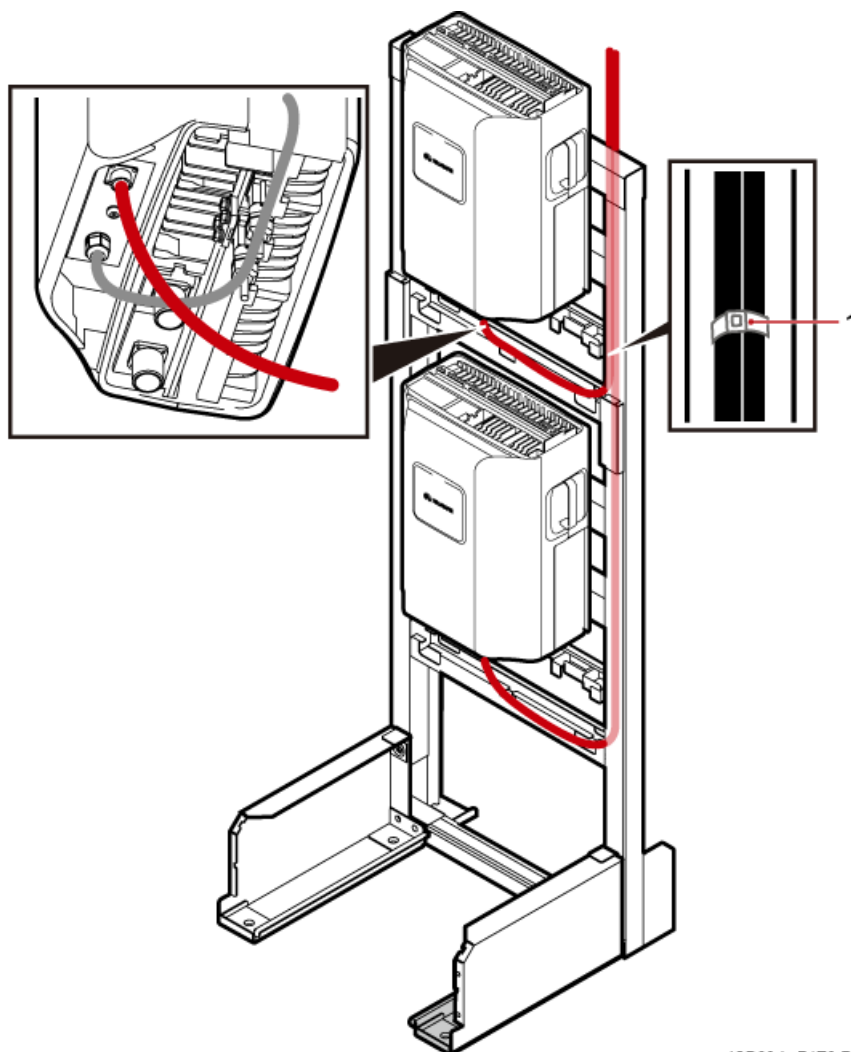

ICD03-LxP1T0-P01

(1) Cable tie

3. Route cables by referring to [15.1 Cabling Requirements](#).
4. Use cable ties to bind cables.
5. Label the installed cables by referring to Attaching a Sign Plate Label.

---End

15.10 Installing the E1/T1 Cable (FE/GE Cable or FE/GE Optical Cable)

This section describes the installation of the E1/T1 cable, FE/GE cable, and FE/GE optical cable. The FE/GE cable and FE/GE optical cable are optional. The following description is based on the installation of the E1/T1 cable.

Context

One end of the FE/GE cable is connected to the **FE0** port on the WMPT/GTMU or **FE/GE** port on the LMPT, and one end of the FE/GE optical cable is connected to the **SFP** port on the LMPT. The cable route of the FE/GE cable or FE/GE optical cable is the same as that of E1/T1 cable.

Procedure

- Step 1** Connect one end of the E1/T1 cable to the **E1/T1** port on the WMPT or GTMU.
- Step 2** Lead the other end out of the IMB03 from the top right, as shown in [Figure 15-34](#).

Figure 15-34 Connections of the E1/T1 cable

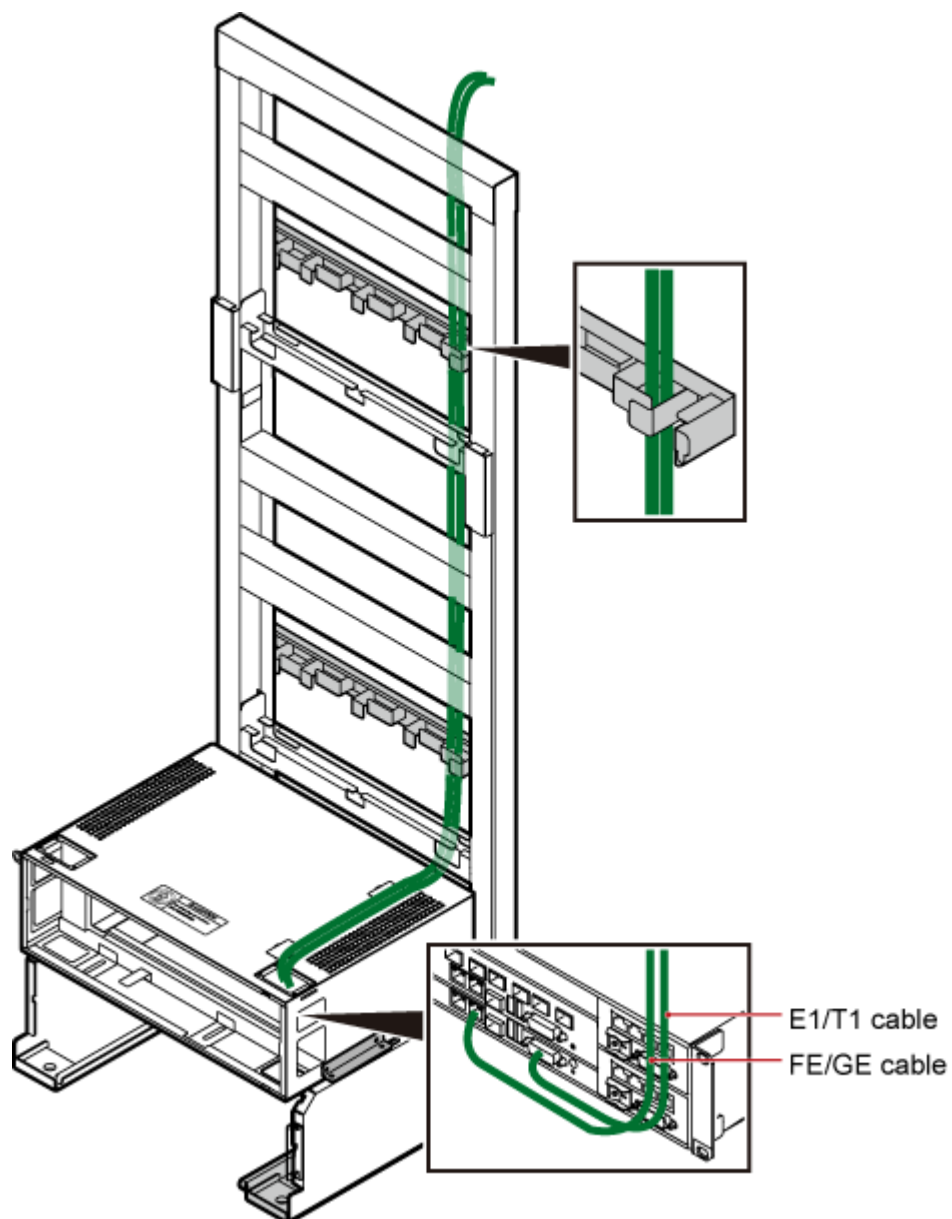

ICD04-L1P070-P01

- Step 3** Route cables by referring to [15.1 Cabling Requirements](#).

Step 4 Use cable ties to bind cables.

Step 5 Label the installed cables by referring to Attaching an L-Shaped Label.

----End

15.11 Installing the CPRI Optical Cable

This section describes the procedure for installing the CPRI optical cable.

Context

- The single-mode optical module is labeled "SM" and multi-mode optical module is labeled "MM".
- If the puller of an optical module is blue, the module is a single-mode optical module. If the puller of an optical module is black or grey, the module is a multi-mode optical module.
- The optical module to be installed must have a matching rate with the corresponding CPRI port.

Procedure

- Installing the CPRI optical cable for the DC RRU
 1. Wear an ESD wrist strap or a pair of ESD gloves.
 2. Turn the puller of each optical module outwards, insert the optical module into the **CPRI** port on the BBU and the **CPRI_W** or **CPRI0** port on the RRU respectively, and then turn the puller inwards, as shown in [Figure 15-35](#).

Figure 15-35 Installing the optical module

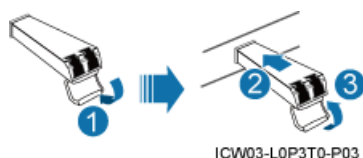

3. Connect one end of the CPRI optical cable to the **CPRI_W** port on the RRU.
4. Connect the other end to the **CPRI** port on the BBU.
5. Route the optical cable in the cable trough by referring to [Figure 15-36](#).



CAUTION

- When routing optical cables, coil the cables and place them on the top center of the upper-level IMB03 to ensure that the holes for heat dissipation are not covered.
- The minimum bending radius of the fiber is 140 mm. When coiling the optical cable, do not bend it excessively.

Figure 15-36 Connections of the CPRI optical cable for six DC RRUs

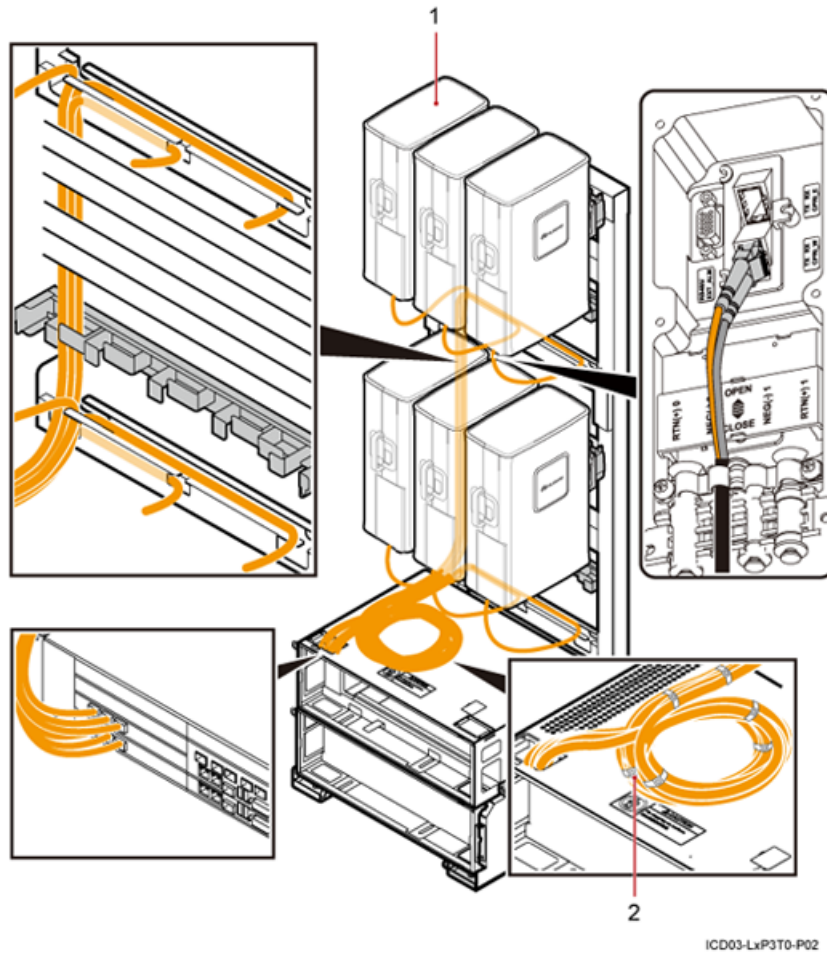

(1) Cable routes for 6 DC RRUs

(2) Every three optical cables tied in a bundle

The cable route of the CPRI optical cable for 12 DC RRUs are slightly different. For details, see [Figure 15-37](#).

Figure 15-37 Connections of the CPRI optical cable for 12 DC RRUs

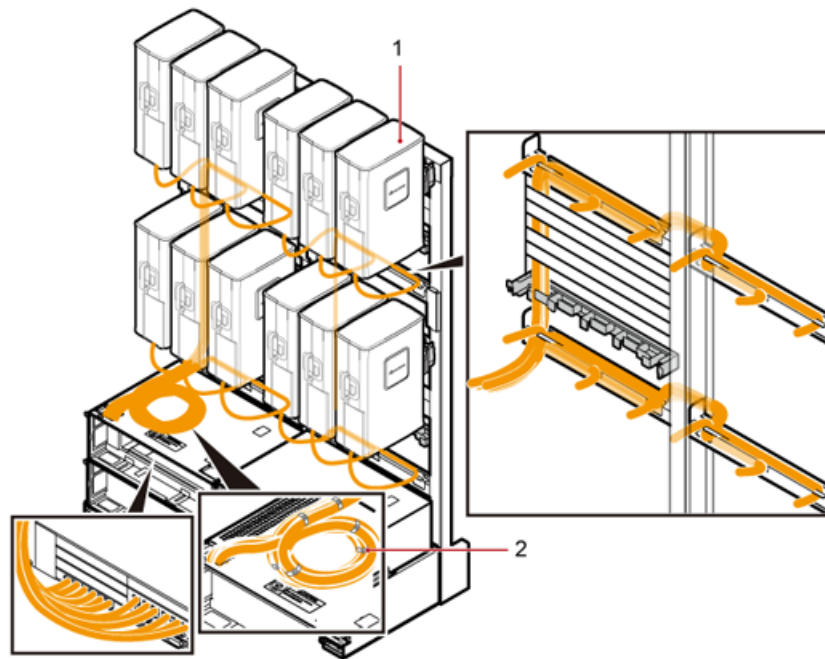

(1) Cable routes for 12 DC RRUs (2) Every three optical cables tied in a bundle

6. Route cables by referring to [15.1 Cabling Requirements](#).
 7. Use cable ties to bind cables.
 8. Label the installed cables by referring to [Attaching an L-Shaped Label](#).
- Installing the CPRI optical cable for the AC RRU
 1. Wear an ESD wrist strap or a pair of ESD gloves.
 2. Turn the puller of each optical module outwards, insert the optical module into the **CPRI** port on the BBU and the **CPRI_W** or **CPRI0** port on the RRU respectively, and then turn the puller inwards, as shown in [Figure 15-38](#).

Figure 15-38 Installing the optical module

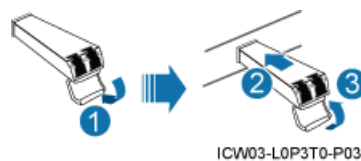

3. Connect one end of the CPRI optical cable to the cabling cavity of the RRU, as shown in [Figure 15-39](#).

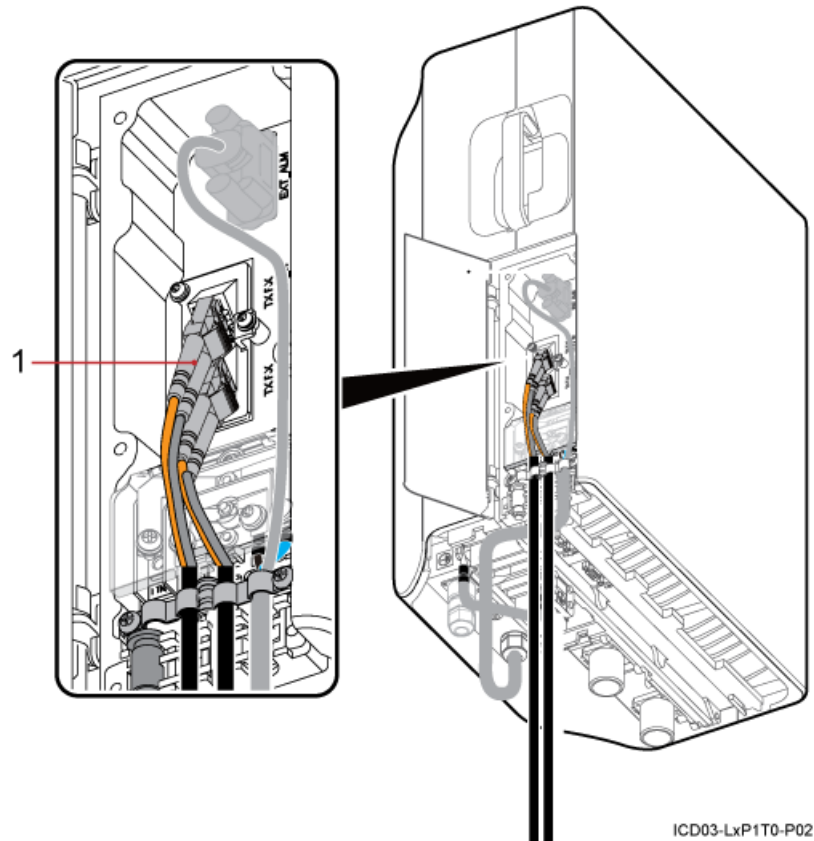
Figure 15-39 Connections of the CPRI optical cable for AC RRUs

(1) CPRI optical cable

4. Connect the other end to the **CPRI** port on the BBU.
5. Route cables by referring to [15.1 Cabling Requirements](#).
6. Use cable ties to bind cables.
7. Label the installed cables by referring to Attaching an L-Shaped Label.

----End

15.12 Installing the Antenna Jumper for the RRU

This section describes the procedure for installing the antenna jumper for the DC RRU.

Context



CAUTION

- Fix a DIN connector near the cable rack before fixing another DIN connector far from the cable rack when installing the antenna jumper for the DC RRU. Pre-bend the RF jumper before connecting it to the RRU.
 - The three wire clips in the middle of the cable trough are used for routing feeders. Each wire clip holds four feeders. You must install the feeders on the lower level before installing the feeders on the upper level.
 - The minimum bending radius of the antenna jumper is 100 mm.
 - When the STMA or Smart Bias-Tee (SBT) is used and the coaxial cable is used for the RET antenna of the RRU3201, OOK signals are required. In this case, the ANT_TX/RXA port is used for communications of the RET antenna.
-

Procedure

- Installing the antenna jumper for the DC RRU
 1. Connect one end of the antenna jumper to the ANT_TX/RXA and ANT_RXB ports at the bottom of the RRU.
 2. Connect the other end to the feeder or antenna, as shown in [Figure 15-40](#).

 **TIP**

Pre-bend the feeder before tightening the feeder connector.

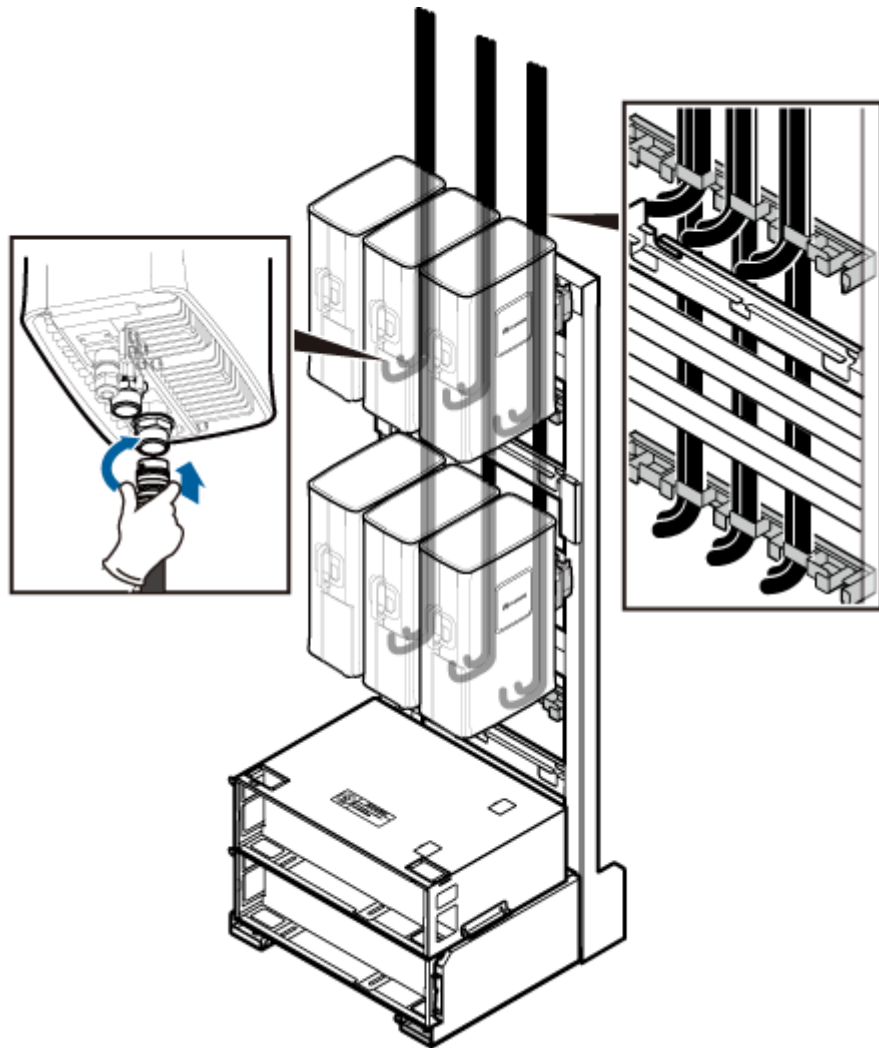
Figure 15-40 Connections of the antenna jumper for the DC RRU

ICD03-L0P3T0-P04

3. Route cables by referring to [15.1 Cabling Requirements](#).
 4. Use cable ties to bind cables.
 5. Label the installed cables by referring to Attaching a Sign Plate Label.
- Installing the antenna jumper for the AC RRU
 1. Connect one end of the antenna jumper to the ANTA and ANTB ports at the bottom of the RRU.
 2. Connect the other end to the feeder or antenna, as shown in [Figure 15-41](#).

 **TIP**

Pre-bend the feeder before tightening the feeder connector.

Figure 15-41 Connections of the antenna jumper for the AC RRU

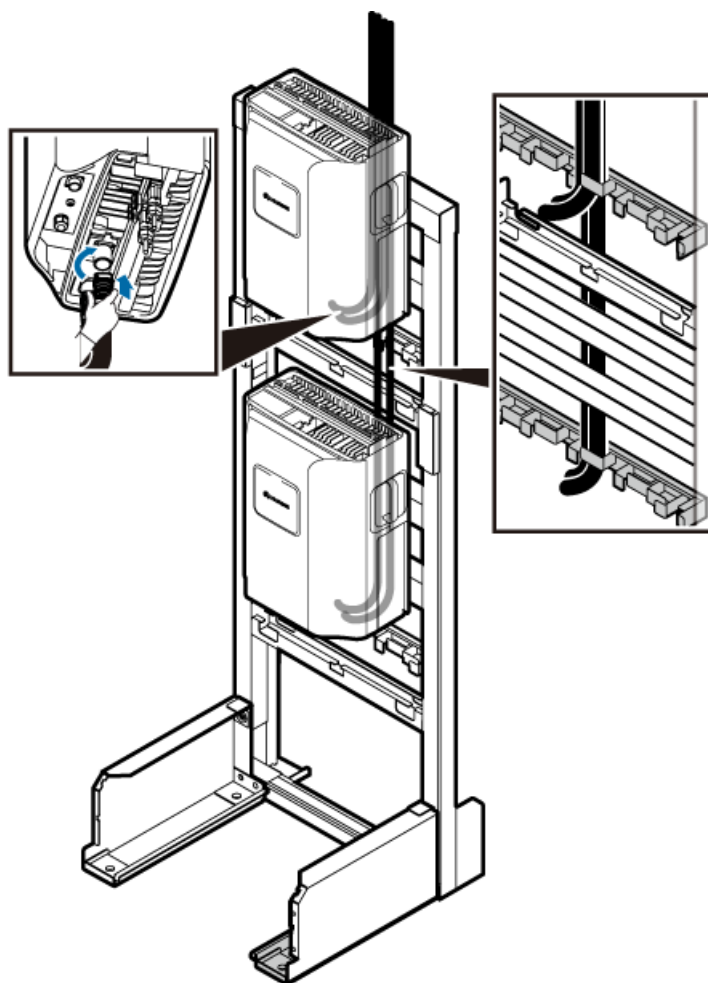

ICD03-LxP1T0-P03

3. Route cables by referring to [15.1 Cabling Requirements](#).
4. Use cable ties to bind cables.
5. Label the installed cables by referring to Attaching a Sign Plate Label.

----End

15.13 Installing a GPS Clock Signal Cable

This section describes the procedure for installing the GPS clock signal cable.

Procedure

- Step 1** Connect the other end of the GPS clock signal cable to the GPS port on the USCU, or LMPT

 **NOTE**

The GPS clock signal cable is connected to the GPS port on the USCU for a base station working in GSM Only, UMTS Only, or GSM+UMTS mode. It is connected to the GPS port on the LMPT for a base station working in LTE Only, UMTS+LTE, or GSM+LTE mode.

The route for the GPS clock signal cable is the same when the cable is connected to the LMPT, or USCU. [Figure 15-42](#) shows the connections of the GPS clock signal cable to the GPS port on the USCU.

Figure 15-42 shows the installation of the GPS clock signal cable.

Figure 15-42 GPS clock signal cable

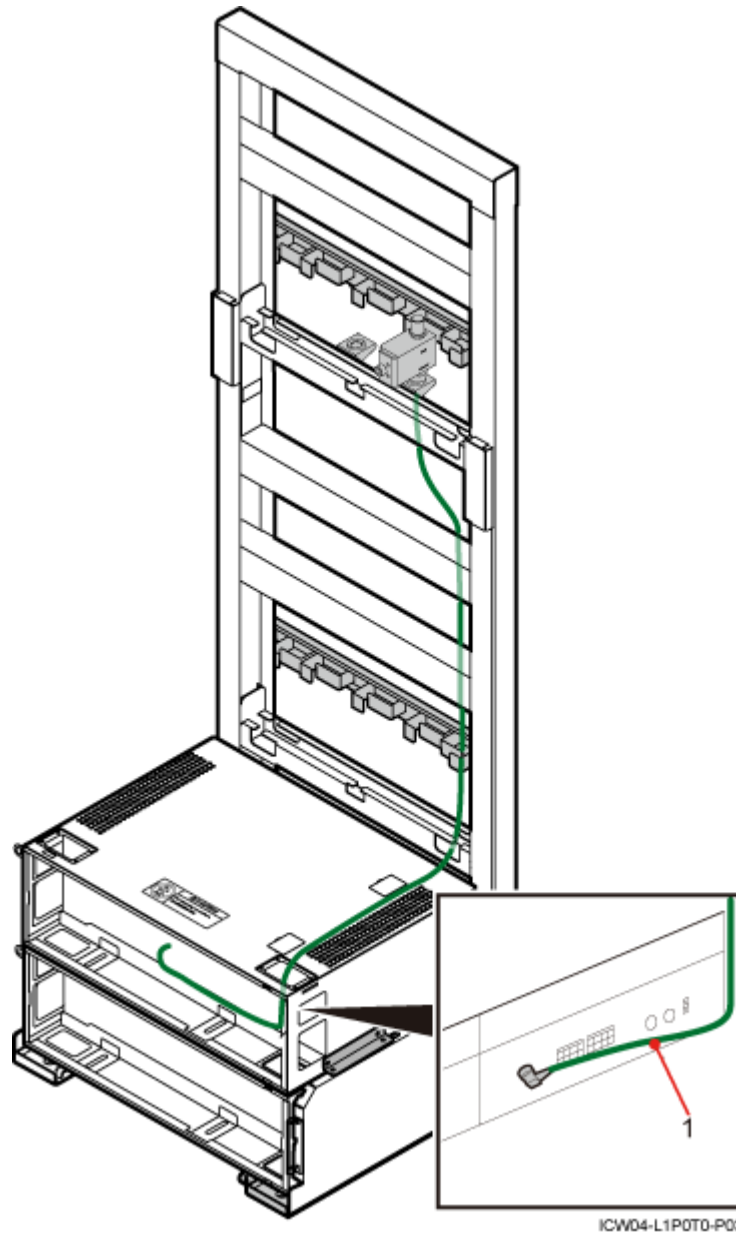

(1) GPS clock signal cable

Step 2 Route cables by referring to [15.1 Cabling Requirements](#).

Step 3 Use cable ties to bind cables.

Step 4 Label the installed cables by referring to Attaching an L-Shaped Label.

----End

16 Checklist for the DBS3900 Hardware Installation

This section describes the checklist for the DBS3900 hardware installation.

Table 16-1 Hardware installation checklist

No.	Item
1	The position for each equipment conforms to the engineering design and meets the space requirement. Sufficient space is reserved for equipment maintenance.
2	The BBU, RRU, and auxiliary devices are securely installed, and all the screws are tightened.
3	The DIP switch on the BBU is correctly set.
4	The cover plate is securely installed on the cabling cavity of the RRU.
5	Waterproof fillers are installed in the idle cable troughs of the cabling cavity of the RRU, and the cover plate of the cabling cavity is securely installed. In addition, the idle RF ports are covered with waterproof caps and waterproofed.
6	All the power cables and PGND cables are not short-circuited or reversely connected. In addition, no damaged or broken parts exist.
7	There are no connectors or joints on the power cable or PGND cable.
8	Tightly press the OT terminal on the conductor when adding the OT terminal to the power cable or PGND cable.
9	The bare wire and OT terminal at the wiring terminal are tightly wrapped with the insulation tape or heat-shrinkable tube.
10	The working grounding and protection grounding of the base station and the surge protection grounding of the building share one group of grounding conductors.
11	The connector of the signal cable is intact, and no damaged or broken parts exist on the cable.

No.	Item
12	The distance between the bundled fiber and the BBU panel is between 40 mm and 70 mm.
13	Labels are correct, legible, and complete on both ends of each cable.

17 Performing the DBS3900 Power-On Check

After all devices are installed, you need to check the power-on status of the BBU and RRU.



CAUTION

- The DBS3900 must be powered on within seven days after it is unpacked, and the period for which the DBS3900 remains powered-off during maintenance must not exceed 48 hours.
 - The RRU must be powered on within 24 hours after it is unpacked, and the period for which the RRU remains powered-off during maintenance must not exceed 24 hours.
-

Checking the Power-On Status of the BBU

[Figure 17-1](#) shows the BBU power-on check process.

Figure 17-1 BBU power-on check process

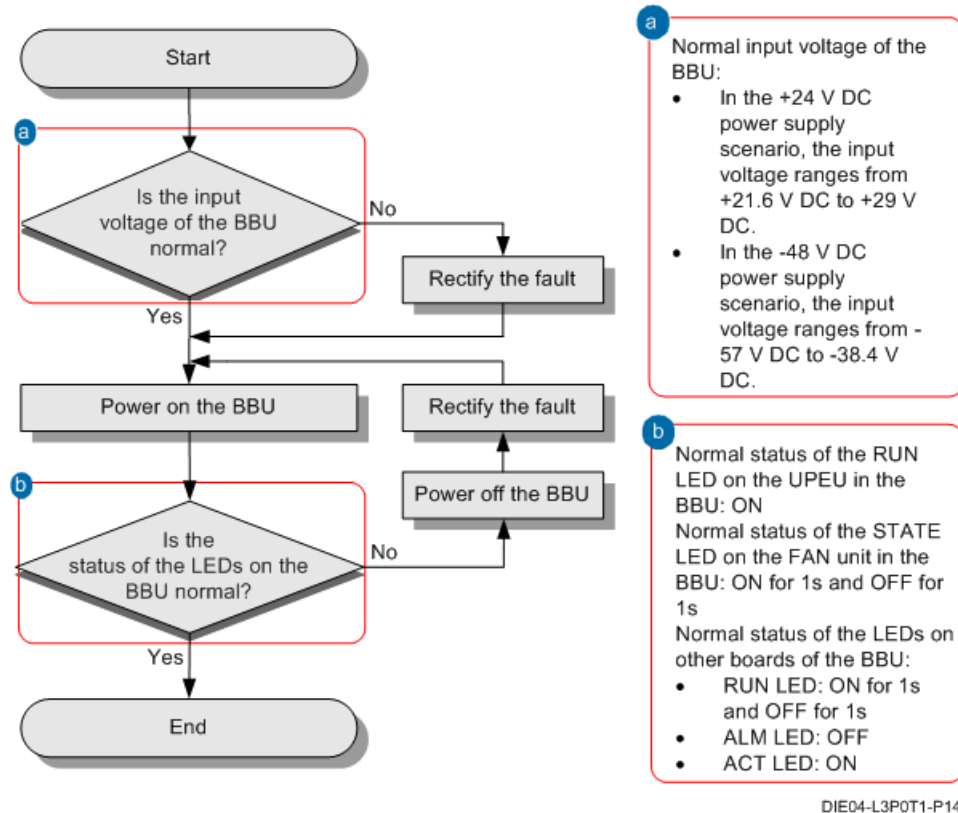

Checking the Power-On Status of the RRU

Figure 17-2 shows the RRU power-on check process.

Figure 17-2 RRU power-on check process

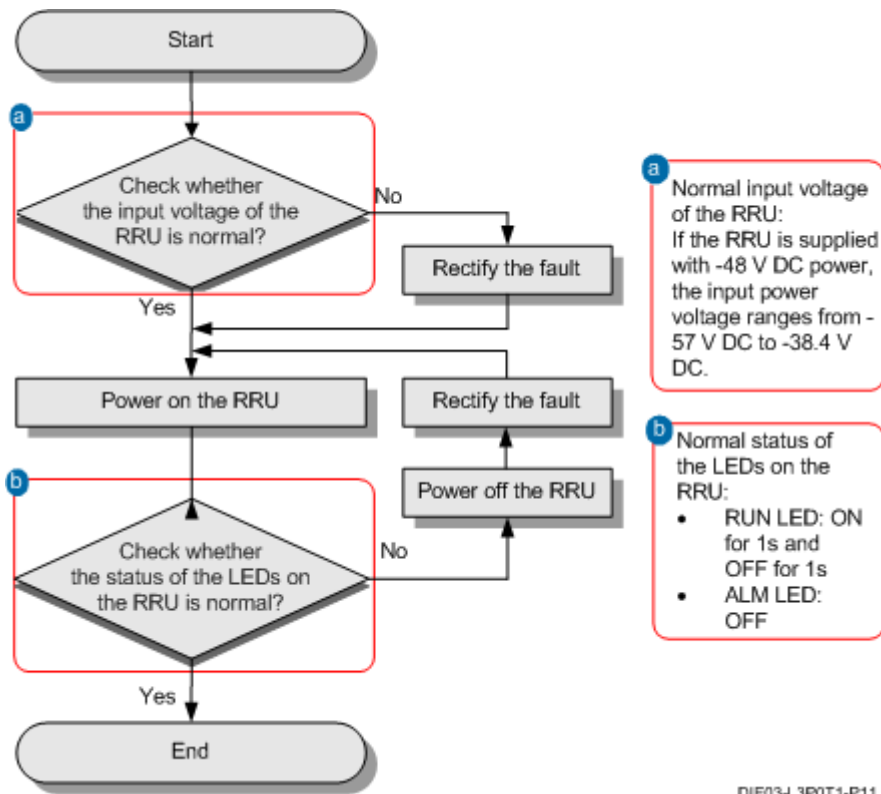

18 Installing the Cover Plate for the IMB03

This section describes the procedure for installing the cover plate for the IMB03.

Procedure

Step 1 Fit the tabs on the cover plate into the slots in the IMB03, as shown in [Figure 18-1](#).

Figure 18-1 Installing the cover plate

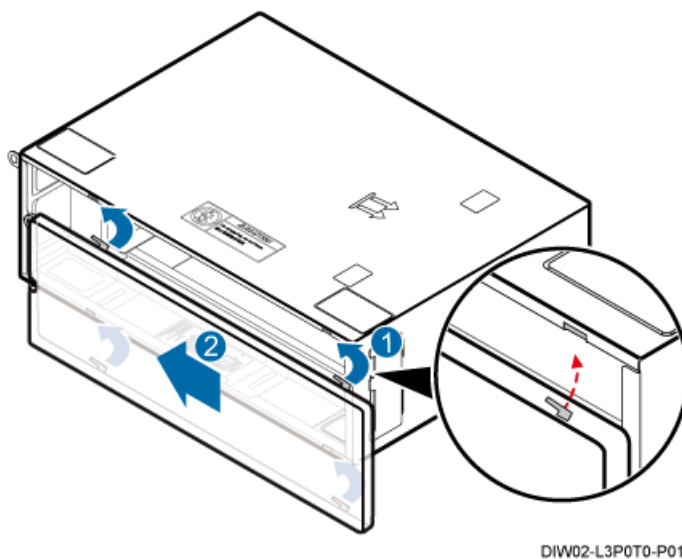

Step 2 Tighten the M3×8 bolt on the left of the cover plate for the IMB03 until the tightening torque reaches 0.3 N·m using a Phillips torque screwdriver, as shown in [Figure 18-2](#).

Figure 18-2 Securing the cover plate

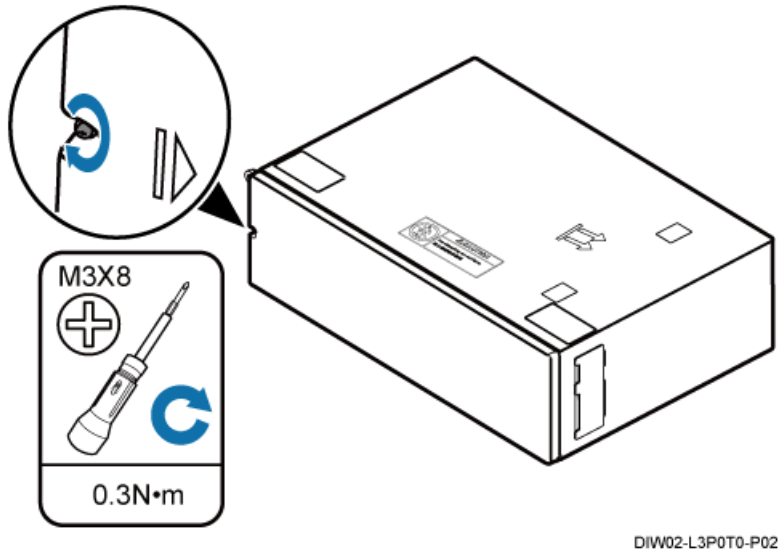

----End