

**DBS3900 LTE TDD
V600R007C00
RRU3276 Installation Guide**

Issue **Draft A**
Date **2015-10-30**

Copyright © Huawei Technologies Co., Ltd. 2015. All rights reserved.

No part of this document may be reproduced or transmitted in any form or by any means without prior written consent of Huawei Technologies Co., Ltd.

Trademarks and Permissions



and other Huawei trademarks are trademarks of Huawei Technologies Co., Ltd.

All other trademarks and trade names mentioned in this document are the property of their respective holders.

Notice

The purchased products, services and features are stipulated by the contract made between Huawei and the customer. All or part of the products, services and features described in this document may not be within the purchase scope or the usage scope. Unless otherwise specified in the contract, all statements, information, and recommendations in this document are provided "AS IS" without warranties, guarantees or representations of any kind, either express or implied.

The information in this document is subject to change without notice. Every effort has been made in the preparation of this document to ensure accuracy of the contents, but all statements, information, and recommendations in this document do not constitute a warranty of any kind, express or implied.

Huawei Technologies Co., Ltd.

Address: Huawei Industrial Base
Bantian, Longgang
Shenzhen 518129
People's Republic of China

Website: <http://www.huawei.com>

Email: support@huawei.com

About This Document

Purpose

This document describes the process of installing a DC RRU3276 (referred to as RRU in this document).

Product Version

The following table lists the product version related to this document.

Product Name	Product Version
eRelay DBS3900	V100R003C00 and later versions

Intended Audience

This document is intended for:

Base station installation engineers

Organization

[1 Change History](#)

This chapter describes changes in the *RRU3276 Installation Guide*.

[2 Installation Preparations](#)

This chapter describes the reference documents, tools, and instruments that must be ready before the installation. In addition, it specifies the skills that installation engineers must have.

[3 Information About the Installation](#)

Before installing an RRU, you must be familiar with its exterior, ports, installation options, physical supports, and installation clearance requirements.

[4 Unpacking the Equipment](#)

This chapter describes how to unpack and check the delivered equipment to ensure that all the materials are included and intact.

5 Installation Process

The installation process involves installing an RRU and RRU cables, checking the RRU hardware installation, and powering on the RRU.

6 Hoisting the RRU and Cables onto a Tower

This section describes how to hoist the RRU and Cables onto a tower and provides important notes about the installation.

7 Installing the RRU

This chapter describes the procedure for installing the RRU. The RRU can be installed on a pole, U-steel, angle steel, or wall as required.

8 Installing RRU Cables

This chapter describes the procedure for installing RRU cables.

9 Checking the RRU Hardware Installation

This section describes how to check RRU hardware installation after the installation is complete.

10 Powering On an RRU

This section describes how to check the power-on status of an RRU after all the devices are installed.





11 Appendix

This section describes the procedure for adding an easy power receptacle (pressfit type) connector.

Conventions

Symbol Conventions

The symbols that may be found in this document are defined as follows.

Symbol	Description
 DANGER	Indicates a hazard with a high level of risk that, if not avoided, will result in death or serious injury.
 WARNING	Indicates a hazard with a medium or low level of risk which, if not avoided, could result in minor or moderate injury.
 CAUTION	Indicates a potentially hazardous situation that, if not avoided, could cause equipment damage, data loss, and performance degradation, or unexpected results.
 TIP	Indicates a tip that may help you solve a problem or save time.
 NOTE	Provides additional information to emphasize or supplement important points of the main text.

General Conventions

Convention	Description
Times New Roman	Normal paragraphs are in Times New Roman.
Boldface	Names of files, directories, folders, and users are in boldface . For example, log in as user root .
<i>Italic</i>	Book titles are in <i>italics</i> .
Courier New	Terminal display is in Courier New.

Command Conventions

Convention	Description
Boldface	The keywords of a command line are in boldface .
<i>Italic</i>	Command arguments are in <i>italics</i> .
[]	Items (keywords or arguments) in square brackets [] are optional.
{ x y ... }	Alternative items are grouped in braces and separated by vertical bars. One is selected.
[x y ...]	Optional alternative items are grouped in square brackets and separated by vertical bars. One or none is selected.
{ x y ... } *	Alternative items are grouped in braces and separated by vertical bars. A minimum of one or a maximum of all can be selected.

GUI Conventions

Convention	Description
Boldface	Buttons, menus, parameters, tabs, windows, and dialog titles are in boldface . For example, click OK .
>	Multi-level menus are in boldface and separated by the ">" signs. For example, choose File > Create > Folder .

Keyboard Operation

Format	Description
Key	Press the key. For example, press Enter and press Tab .

Format	Description
Key 1+Key 2	Press the keys concurrently. For example, pressing Ctrl+Alt+A means the three keys should be pressed concurrently.
Key 1, Key 2	Press the keys in turn. For example, pressing Alt, A means the two keys should be pressed in turn.

Mouse Operation

Action	Description
Click	Select and release the primary mouse button without moving the pointer.
Double-click	Press the primary mouse button twice continuously and quickly without moving the pointer.
Drag	Press and hold the primary mouse button and move the pointer to a certain position.

Contents

About This Document	ii
1 Change History	1
2 Installation Preparations	2
2.1 Reference Documents	2
2.2 Tools and Instruments	2
2.3 Skills and Requirements for Onsite Personnel	4
3 Information About the Installation	5
3.1 RRU Exterior	5
3.2 RRU Ports	6
3.3 RRU Indicators.....	8
3.4 Installation Options	10
3.5 Installation Clearance Requirements of an RRU.....	15
3.5.1 Clearance for a Single RRU	15
3.5.2 Clearance for Multiple RRUs.....	17
3.5.3 Spacing Between RRUs	20
4 Unpacking the Equipment	23
5 Installation Process	25
6 Hoisting the RRU and Cables onto a Tower	26
6.1 Installing an RRU on a Tower	26
6.2 Hoisting Fiber Optic Cables onto a Tower	30
6.3 Hoisting Power Cables onto a Tower	33
7 Installing the RRU	37
7.1 Mounting Kits for an RRU	38
7.2 Installing the RRU on a Pole.....	38
7.2.1 Installing a Single RRU	43
7.2.2 Installing Two RRUs.....	46
7.2.3 Installing Multiple RRUs	48
7.3 Installing the RRU on U-Steel.....	53
7.4 Installing the RRU on Angle Steel	57
7.5 Installing the RRU on a Wall.....	60

8 Installing RRU Cables.....	65
8.1 Cabling Requirements	66
8.2 Cable Connections	72
8.3 Installation Process.....	76
8.4 RRU Cable List	77
8.5 Installing an RRU PGND Cable.....	79
8.6 Installing an RRU RF Jumper	80
8.7 Installing an RRU Alarm Cable.....	83
8.8 Installing an RRU AISG Multi-Wire Cable and an RRU AISG Extension Cable.....	84
8.9 Opening the Cover Plate of an RRU Cabling Cavity	87
8.10 Installing an RRU Power Cable	89
8.11 Installing an Optical Fiber Cable.....	90
8.12 Closing the Cover Plate of an RRU Cabling Cavity	92
9 Checking the RRU Hardware Installation	95
10 Powering On an RRU	96
11 Appendix	98
11.1 Adding an Easy Power Receptacle (Pressfit Type) Connector to an RRU Power Cable	98

1 Change History

This chapter describes changes in the *RRU3276 Installation Guide*.

Draft A (2015-10-30)

This is a draft.

2 Installation Preparations

About This Chapter

This chapter describes the reference documents, tools, and instruments that must be ready before the installation. In addition, it specifies the skills that installation engineers must have.

2.1 Reference Documents

Before the installation, you must be familiar with reference documents.

2.2 Tools and Instruments

All tools and instruments required for RRU installation must be ready before the installation.

2.3 Skills and Requirements for Onsite Personnel

Onsite personnel must be qualified and trained. Before performing any operation, onsite personnel must be familiar with correct operation methods and safety precautions.

2.1 Reference Documents

Before the installation, you must be familiar with reference documents.

The following reference documents are required during RRU installation:











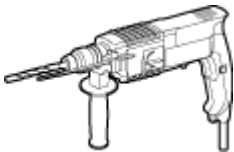
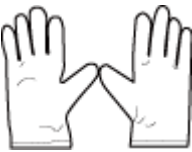





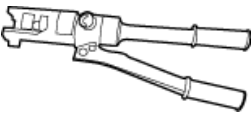
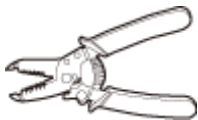



- RRU3276 Hardware Description
- DBS3900 Installation Guide
- OCB-01M User Guide

This document describes the RRU installation on a pole, U-steel, angle steel, or wall. If RRUs are installed on the IFS06, the following reference document is required:

- DBS3900 (ICR) Installation Guide

2.2 Tools and Instruments

All tools and instruments required for RRU installation must be ready before the installation.

<p>Hammer drill (ϕ 12 bit to ϕ 14 bit)</p> 	<p>Electrostatic discharge (ESD) gloves</p> 	<p>Vacuum cleaner</p> 
<p>Heat gun</p> 	<p>Phillips screwdriver (M3 to M6)</p> 	<p>Flat-head screwdriver (M3 to M6)</p> 
<p>Rubber mallet</p> 	<p>Hydraulic pliers</p> 	<p>Wire stripper</p> 
<p>Utility knife</p> 	<p>Cable cutter</p> 	<p>Level</p> 
<p>Adjustable wrench (capacity \geq 32 mm)</p>  <p>Torque wrench</p>  <p>Capacity: 17 mm, 21 mm, and 32 mm</p> <p>Combination wrench</p>  <p>Capacity: 17 mm, 21 mm, and 32 mm</p>	<p>Torque screwdriver</p>   <p>5 mm</p>  <p>(M3 to M6)</p>  <p>(M3 to M6)</p>	<p>Torque socket</p> 
<p>Multimeter</p> 	<p>Marker (diameter \leq 10 mm)</p> 	<p>Measuring tape</p> 

2.3 Skills and Requirements for Onsite Personnel

Onsite personnel must be qualified and trained. Before performing any operation, onsite personnel must be familiar with correct operation methods and safety precautions.

Before the installation, pay attention to the following items:

- The customer's technical engineers must be trained by Huawei and be familiar with the proper installation and operation methods.
- The number of onsite personnel depends on the engineering schedule and installation environment. Generally, only three to five onsite personnel are necessary.

3 Information About the Installation

About This Chapter

Before installing an RRU, you must be familiar with its exterior, ports, installation options, physical supports, and installation clearance requirements.

[3.1 RRU Exterior](#)

This section describes the exterior and dimensions of an RRU.

[3.2 RRU Ports](#)

This section describes ports on the RRU panels. An RRU has a bottom panel, cabling cavity panel, and indicator panel.

[3.3 RRU Indicators](#)

This section describes six indicators on an RRU. They indicate the running status.

[3.4 Installation Options](#)

This section describes RRU installation options. An RRU can be installed on a pole, U-steel, angle steel, or wall.

[3.5 Installation Clearance Requirements of an RRU](#)

This section describes the requirements for the installation clearance of a single RRU and multiple RRUs and the requirements for the installation spacing between RRUs.

3.1 RRU Exterior

This section describes the exterior and dimensions of an RRU.

[Figure 3-1](#) shows an RRU.

Figure 3-1 RRU exterior

Figure 3-2 shows RRU dimensions.

Figure 3-2 RRU dimensions

3.2 RRU Ports

This section describes ports on the RRU panels. An RRU has a bottom panel, cabling cavity panel, and indicator panel.

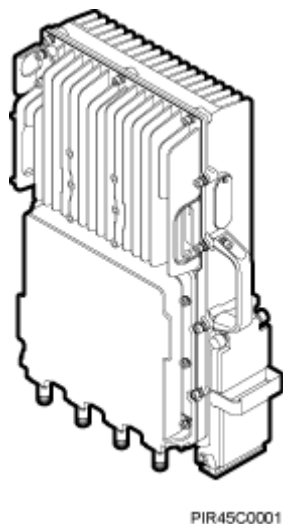
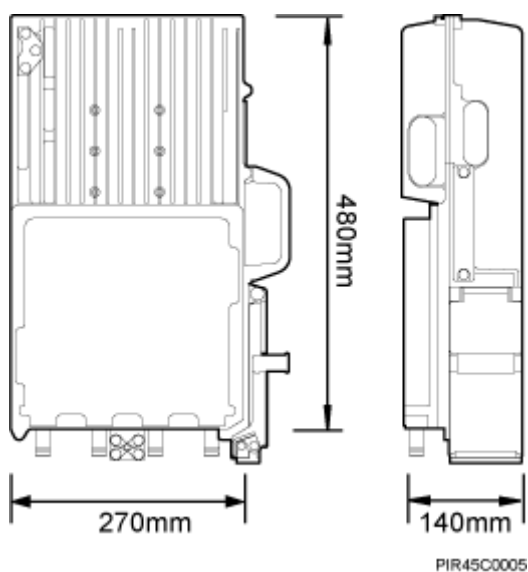
Figure 3-3 shows the ports on the RRU panels.

Figure 3-3 Ports on the RRU panels

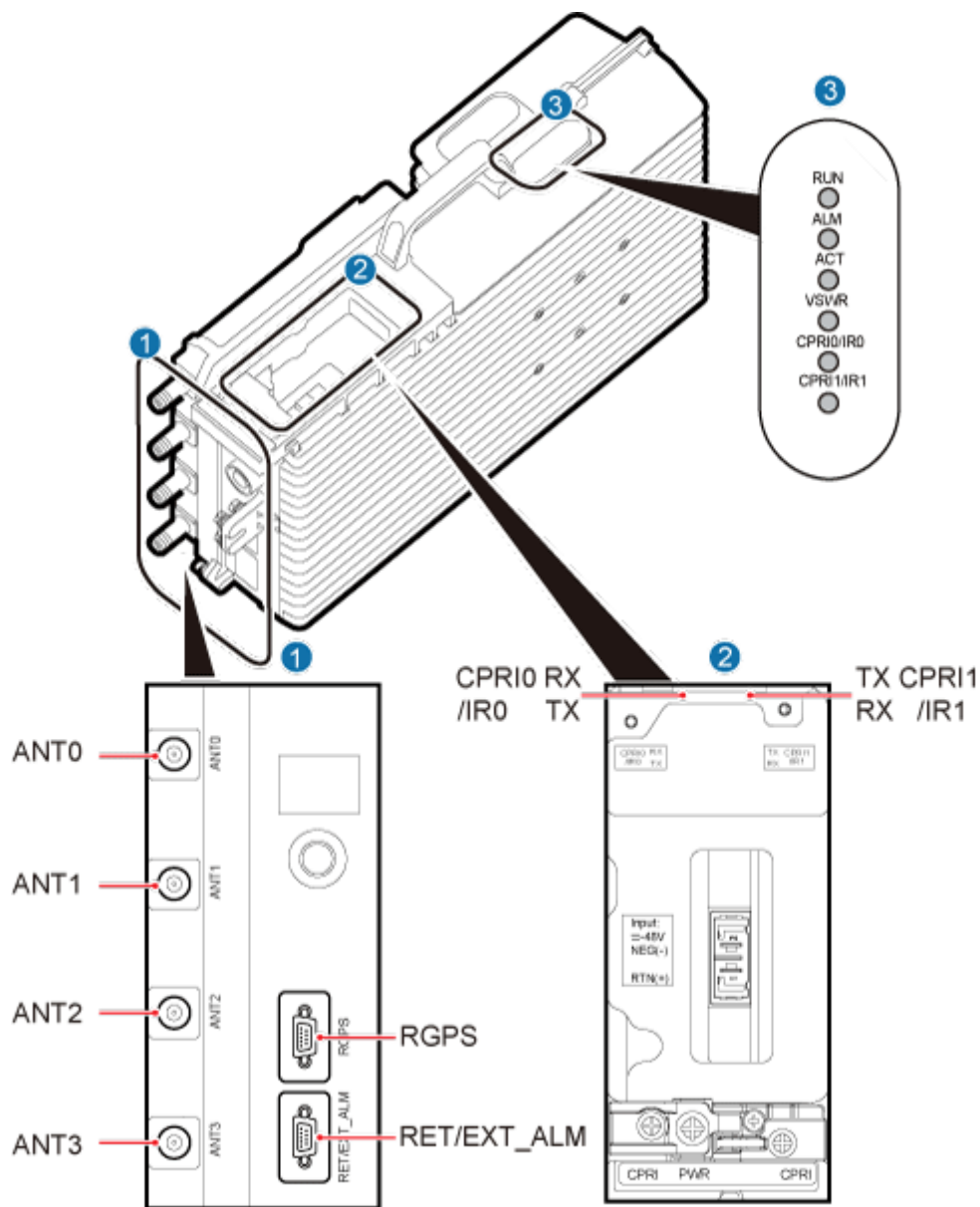

PIR45C0202

Table 3-1 describes ports and indicators on the RRU panels.

Table 3-1 Ports and indicators on the RRU panels

Item	Label	Description
(1) Ports at the bottom	ANT0-ANT3	TX/RX ports. ANT0 port supports RET signal transmission.
	RET/EXT_ALM	Communication port for the RET antenna or port for alarm reporting, supporting RET signal transmission

Item	Label	Description
	RGPS	RGPS port, which is optional.
(2) Ports in the cabling cavity	CPRI0/IR0	Optical port
	CPRI1/IR1	
	RTN(+)	Power supply socket
	NEG(-)	
(3) Indicators	RUN	For details, see 3.3 RRU Indicators .
	ALM	
	ACT	
	VSWR	
	CPRI0/IR0	
	CPRI1/IR1	

**NOTE**

If only two RF ports are required, ANT0 and ANT1 are used by default.
The RET ports to be used are determined by the software configuration.

3.3 RRU Indicators

This section describes six indicators on an RRU. They indicate the running status.

For the specific positions of RRU indicators, see [3.2 RRU Ports](#).

[Table 3-2](#) describes RRU indicators.

Table 3-2 Indicators on the RRU

Label	Color	Status	Description
RUN	Green	Steady on	There is power supply, but the module is faulty.
		Steady off	There is no power supply, or the module is faulty.
		Blinking on for 1s and off for 1s	The module is working properly.
		Blinking on for 0.125s and off for 0.125s	Software is being loaded to the module, or the module is not started.
ALM	Red	Steady on	Alarms are generated, and the module must be replaced.
		Steady off	No alarm is generated.

Label	Color	Status	Description
		Blinking on for 1s and off for 1s	Alarms are generated. The alarms may be caused by the faults on the related modules or ports. Therefore, the necessity for module replacement is uncertain.
ACT	Green	Steady on	The module is working properly with TX channels enabled or software is being loaded without RRU running.
		Blinking on for 1s and off for 1s	The module is working properly with TX channels disabled.
VSWR	Red	Steady off	No VSWR alarm is generated.
		Steady on	A VSWR alarm is generated.
CPRI0/I R0	Red or green	Steady green	The CPRI link is functioning properly.
		Steady red	An optical module fails to transmit or receive signals possibly because the optical module is faulty or the optical fiber cable is broken.
		Blinking red on for 1s and off for 1s	The CPRI link is out of lock possibly because of mutual lock of dual-mode clock sources or mismatched data rates over CPRI ports. (You are advised to check the system configuration to rectify the fault.)
		Steady off	The SFP module is not properly installed, or the optical module is powered off.
CPRI1/I R1	Red or green	Steady green	The CPRI link is functioning properly.
		Steady red	An optical module fails to transmit or receive signals possibly because the optical module is faulty or the optical fiber cable is broken.
		Blinking red on for 1s and off for 1s	The CPRI link is out of lock possibly because of mutual lock of dual-mode clock sources or mismatched data rates over CPRI ports. (You are advised to check the system configuration to rectify the fault.)
		Steady off	The SFP module is not properly installed, or the optical module is

Label	Color	Status	Description
			powered off.

3.4 Installation Options

This section describes RRU installation options. An RRU can be installed on a pole, U-steel, angle steel, or wall.

Installing an RRU on a Pole

Figure 3-4 shows the diameter of a metal pole for installing an RRU.

Figure 3-4 Diameter of a pole

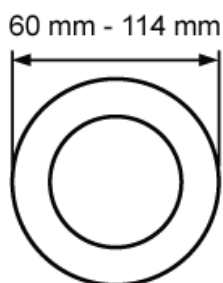

HIR06C0039



CAUTION

- The diameter of a pole for installing an RRU ranges from 60 mm to 114 mm (2.36 in. to 4.49 in.). The recommended diameter is 80 mm (3.15 in.).
- If the diameter of a pole ranges from 60 mm to 76 mm (2.36 in. to 2.99 in.), a maximum of three RRUs can be installed on the pole and the side-mounted installation must not be adopted.
- If three or more RRUs must be installed on a pole in centralized mode, the diameter of the pole must range from 76 mm to 114 mm (2.99 in. to 4.49 in.).
- The recommended pole thickness is 3.5 mm (0.14 in.) or thicker.
- The angle between the vertical plane and the pole, angle steel, or U-steel must be smaller than or equal to 10° , as shown in [Figure 3-5](#).

Figure 3-5 Requirement of the angle between the ground and the pole, angle steel, or U-steel

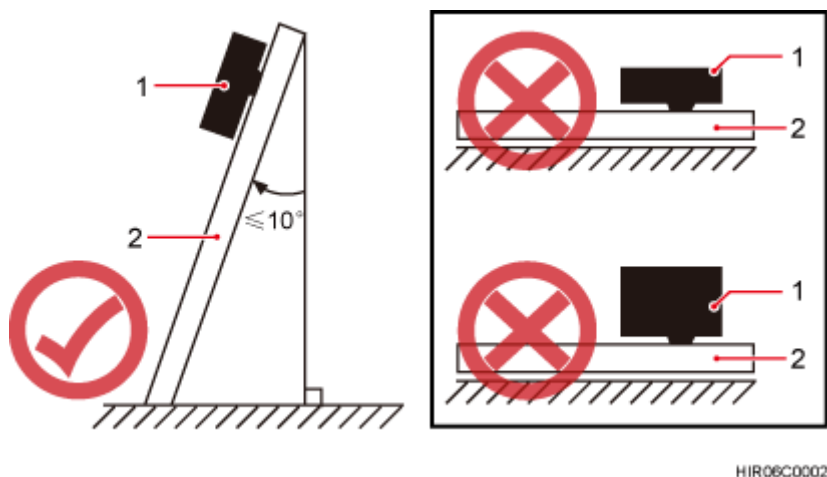

(1) RRU

(2) Pole, angle steel, or U-steel

[Figure 3-6](#) shows an RRU installed on a pole.

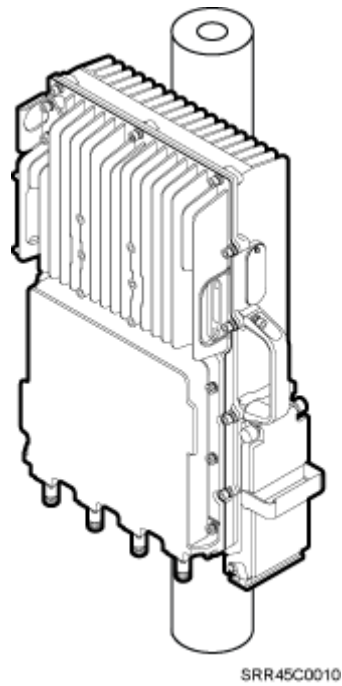
Figure 3-6 RRU installed on a pole

Installing an RRU on U-steel



CAUTION

It is recommended that only one RRU be installed on U-steel.

Figure 3-7 shows U-steel specifications.

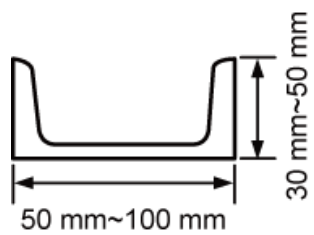
Figure 3-7 U-steel specifications

HIR06C0037

Figure 3-8 shows an RRU installed on U-steel.

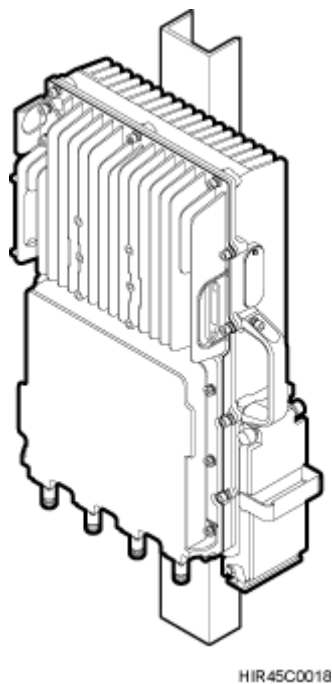
Figure 3-8 RRU installed on U-steel

Installing an RRU on Angle Steel

Figure 3-9 shows angle steel specifications.

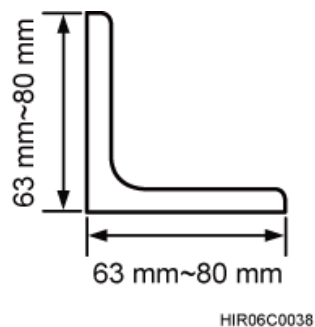
Figure 3-9 Angle steel specifications

It is recommended that only one RRU be installed on angle steel.

Figure 3-10 shows an RRU installed on angle steel.

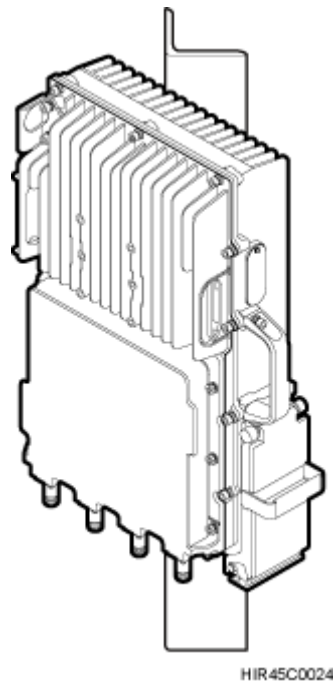
Figure 3-10 RRU installed on angle steel

Installing an RRU on a Wall

The wall on which RRUs are installed must meet the following requirements:

- When a single RRU is installed, the wall has a capacity of bearing at least four times the weight of the RRU.
- Expansion bolts must be tightened with a torque of 30 N·m (265.52 lbf·in.) to ensure the bolts work properly and the wall remains intact without cracks in it.

[Figure 3-11](#) shows an RRU installed on a wall.

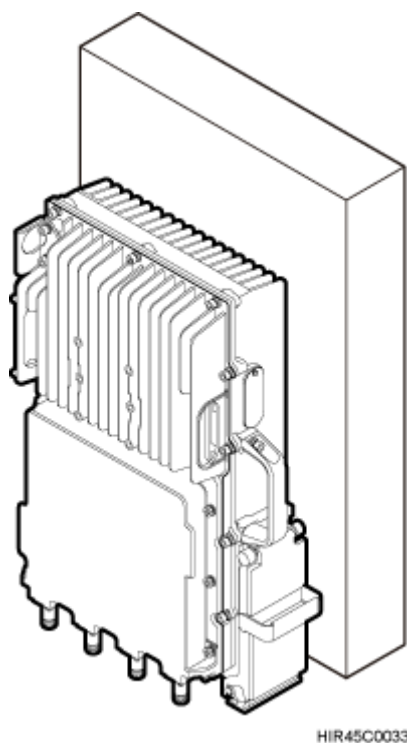
Figure 3-11 RRU installed on a wall

HIR45C0033

3.5 Installation Clearance Requirements of an RRU

This section describes the requirements for the installation clearance of a single RRU and multiple RRUs and the requirements for the installation spacing between RRUs.

NOTE

The recommended installation clearance ensures normal running and provides an appropriate space for OM. If there is sufficient space, leave the recommended installation clearance.

The minimum installation clearance ensures normal running and heat dissipation, but OM activities such as checking indicator status and opening the maintenance cavity cannot be properly conducted. If the installation space is restricted, leave the minimum installation clearance.

3.5.1 Clearance for a Single RRU

This section describes the recommended and minimum clearance for a single RRU.

Recommended Clearance for a Single RRU

[Figure 3-12](#) shows the recommended clearance for a single RRU.

Figure 3-12 Recommended clearance for a single RRU

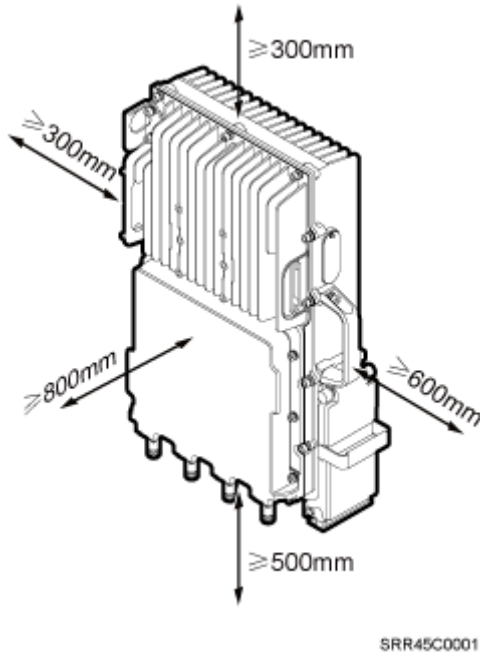

Minimum Clearance for a Single RRU

Figure 3-13 shows the minimum clearance for a single RRU.

Figure 3-13 Minimum clearance for a single RRU

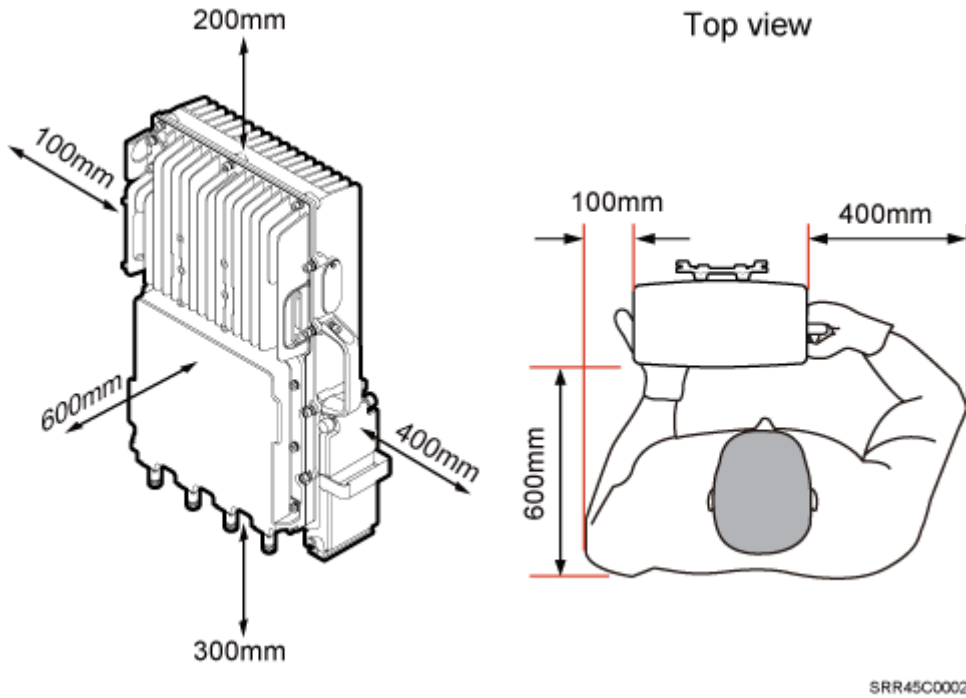

Minimum Clearance for a Single RRU Installed on a Tower

Figure 3-14 shows the minimum clearance for a single RRU installed on a tower.

Figure 3-14 Minimum clearance for a single RRU installed on a tower

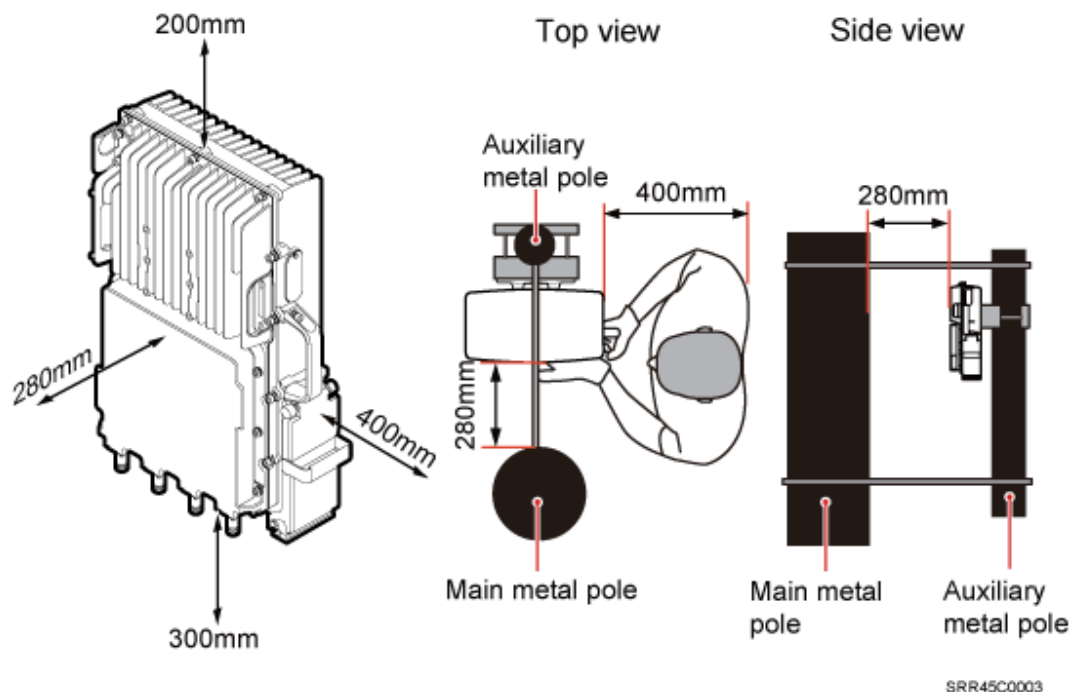

3.5.2 Clearance for Multiple RRUs

This section describes the recommended and minimum clearance for multiple RRUs.

Recommended Clearance for Multiple RRUs Installed in Centralized Mode

Figure 3-15 shows the recommended clearance for multiple RRUs installed in centralized mode.

Figure 3-15 Recommended clearance for multiple RRUs installed in centralized mode

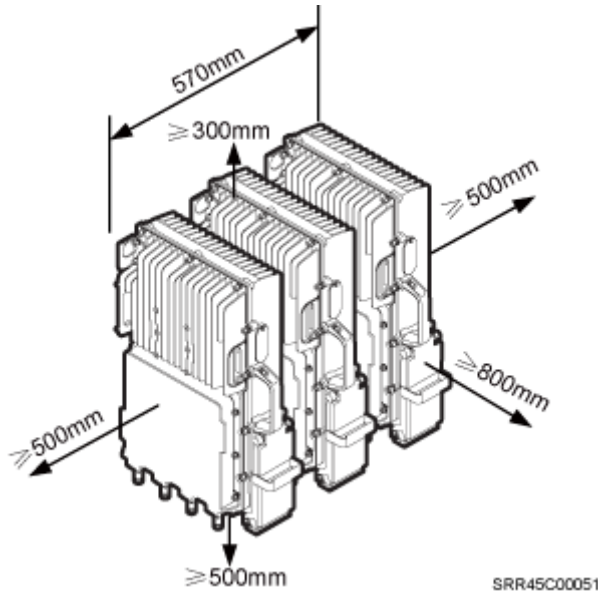

Minimum Clearance for Multiple RRUs Installed in Centralized Mode

Figure 3-16 shows the minimum clearance for multiple RRUs installed in centralized mode.

Figure 3-16 Minimum clearance for multiple RRUs installed in centralized mode

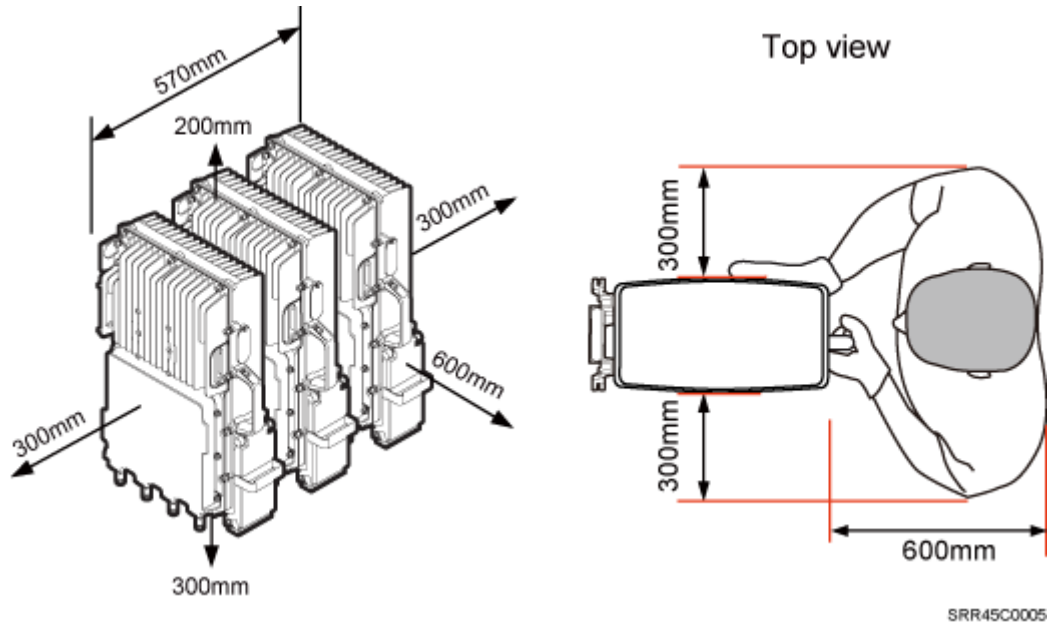

Recommended clearance for multiple RRUs installed on a wall in standard mode

Figure 3-17 shows the recommended clearance for multiple RRUs installed on a wall in standard mode.

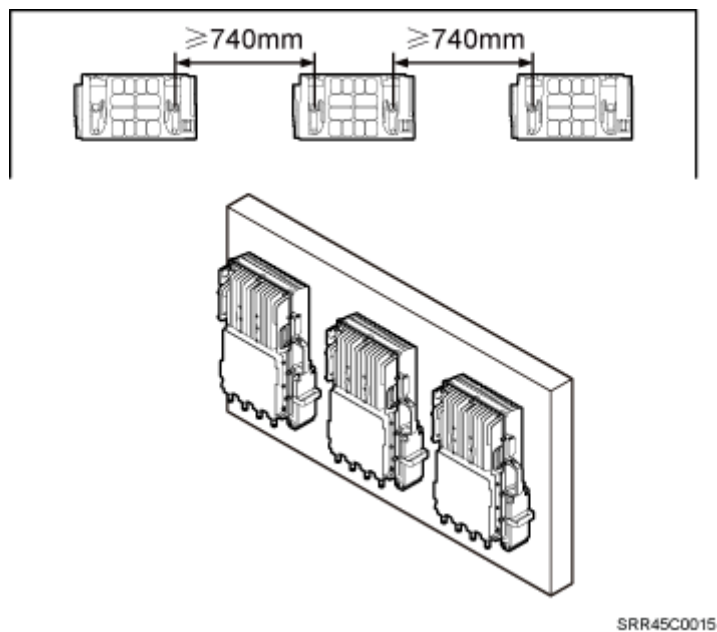
Figure 3-17 Recommended clearance for multiple RRUs installed on a wall in standard mode

Minimum clearance for multiple RRUs installed on a wall in standard mode

Figure 3-18 shows the minimum clearance for multiple RRUs installed on a wall in standard mode.

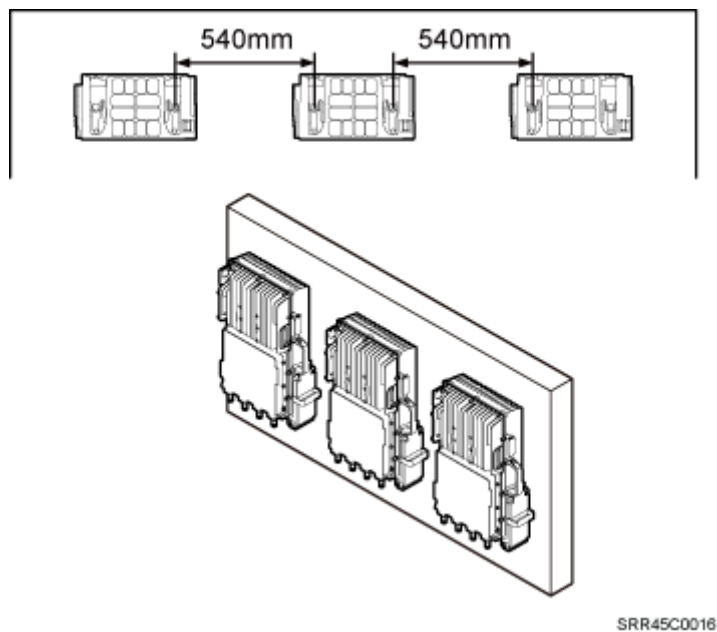
Figure 3-18 Minimum clearance for multiple RRUs installed on a wall in standard mode

Recommended Clearance for Multiple RRUs Side-Mounted on a Wall

Figure 3-19 shows the recommended clearance for multiple RRUs side-mounted on a wall.

Figure 3-19 Recommended clearance for multiple RRUs side-mounted on a wall

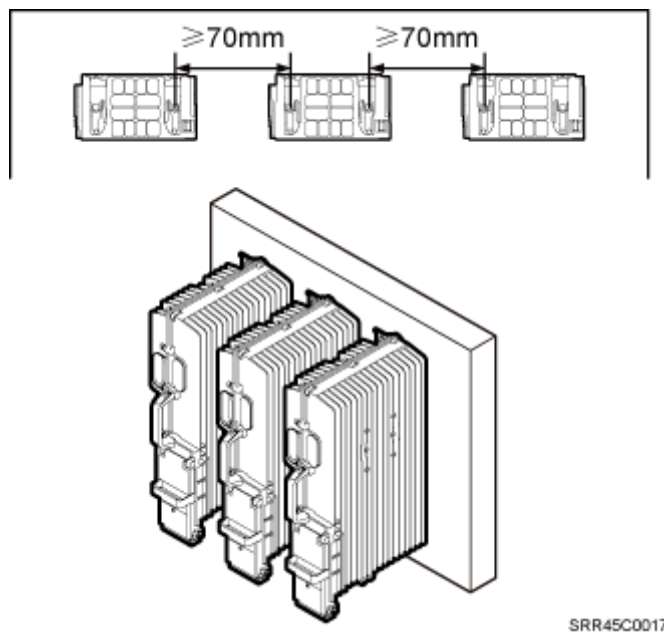

3.5.3 Spacing Between RRUs

This section describes the horizontal and vertical installation spacing between RRUs.

Recommended horizontal spacing between RRUs

Figure 3-20 shows the recommended horizontal spacing between RRUs.

Figure 3-20 Recommended horizontal spacing between RRUs

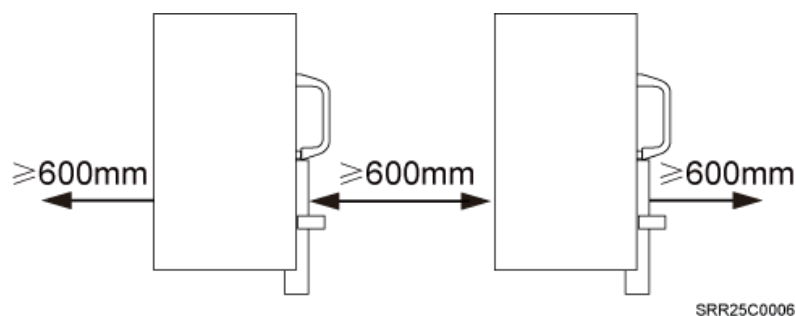

Minimum horizontal spacing between RRUs

Figure 3-21 shows the minimum horizontal spacing between RRUs.

Figure 3-21 Minimum horizontal spacing between RRUs

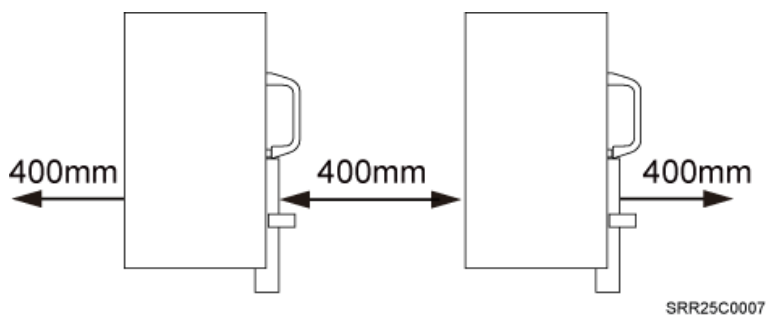

Recommended vertical spacing between RRUs

Figure 3-22 shows the recommended vertical spacing between RRUs.

Figure 3-22 Recommended vertical spacing between RRUs

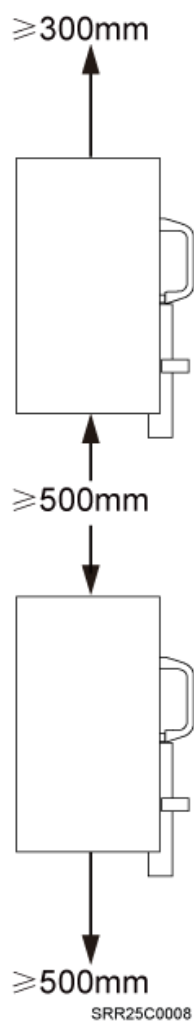

Minimum vertical spacing between RRUs

Figure 3-23 shows the minimum vertical spacing between RRUs.

Figure 3-23 Minimum vertical spacing between RRUs

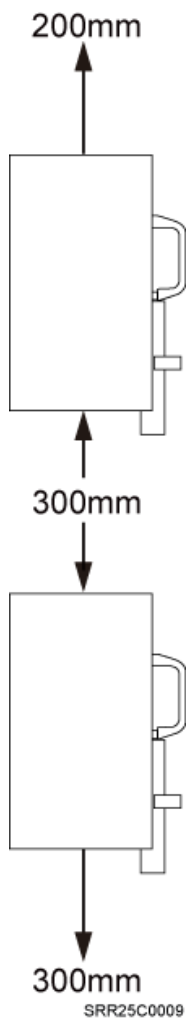

4 Unpacking the Equipment

This chapter describes how to unpack and check the delivered equipment to ensure that all the materials are included and intact.

Context



NOTE

When transporting, moving, or installing the equipment, components, or parts, you must:

- Prevent them from colliding with doors, walls, shelves, or other objects.
- Wear clean gloves, and avoid touching the equipment, components, or parts with bare hands, sweat-soaked gloves, or dirty gloves.



CAUTION

- After a cabinet or an BBU is unpacked, it must be powered on within 7 days.
- After an RRU is unpacked, it must be powered on within 24 hours.

Procedure

Step 1 Check the total number of articles in each case according to the packing list.

If ...	Then ...
The total number tallies with the packing list	Go to Step 2 .
The total number does not tally with the packing list	Find out the cause and report any missing articles to the local Huawei office.

Step 2 Check the exterior of the packing case.

If ...	Then ...
The outer packing is intact	Go to Step 3 .
The outer packing is severely damaged or soaked	Find out the cause and report it to the local Huawei office.
The shockwatch label is red	Stop unpacking the wooden crate, and then report it to the transportation company.

Step 3 Check the type and quantity of the equipment in the cases according to the packing list.

If ...	Then ...
Types and quantity of the article tally with those on the packing list	Sign the <i>Packing List</i> with the customer.
Either shipment shortage, wrong shipment or damaged articles.	Report to the local Huawei office.



WARNING

To protect the equipment and prevent damage to the equipment, you are advised to keep the unpacked equipment and packing materials indoors, take photos of the stocking environment, packing case or carton, packing materials, and any rusted or eroded equipment, and then file the photos.

----End

5 Installation Process

The installation process involves installing an RRU and RRU cables, checking the RRU hardware installation, and powering on the RRU.

Figure 5-1 shows the process of installing an RRU.

Figure 5-1 Process of installing an RRU

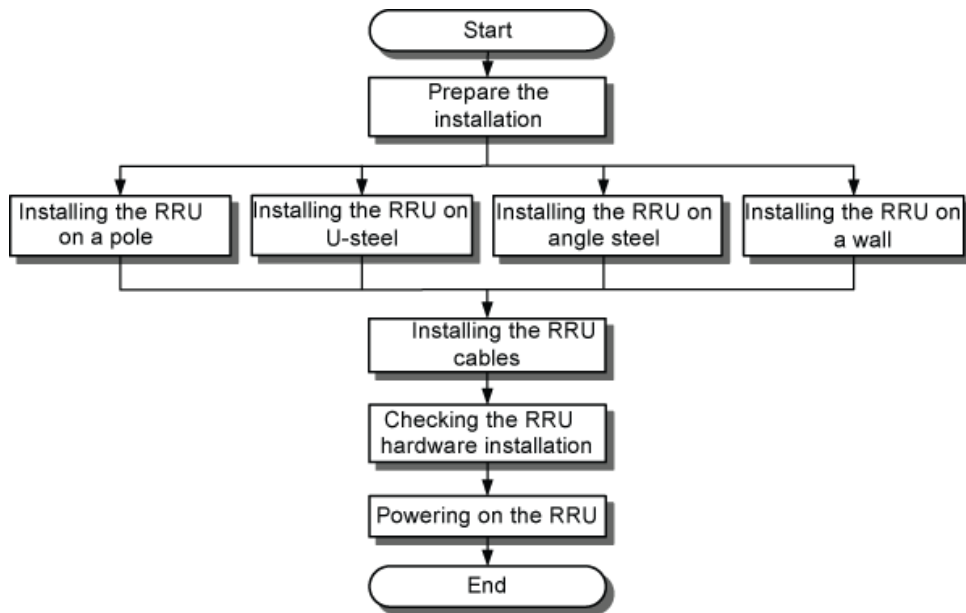

IPR06C0001

6 Hoisting the RRU and Cables onto a Tower

About This Chapter

This section describes how to hoist the RRU and Cables onto a tower and provides important notes about the installation.

6.1 Installing an RRU on a Tower

This section describes the procedure for installing an RRU on a tower and the precautions that must be taken. The RRU can be installed on a pole, U-steel, or angle steel.

6.2 Hoisting Fiber Optic Cables onto a Tower

This section describes the procedure for hoisting fiber optic cables onto a tower and the precautions that must be taken.

6.3 Hoisting Power Cables onto a Tower

This section describes the procedure for hoisting power cables onto a tower and the precautions that must be taken.

6.1 Installing an RRU on a Tower

This section describes the procedure for installing an RRU on a tower and the precautions that must be taken. The RRU can be installed on a pole, U-steel, or angle steel.

Prerequisites

Place a foam pad or cardboard on the ground to protect the housing of the RRU from damage before the binding. Do not stand the RRU upright because the load-bearing capacity of the RF ports at the RRU bottom is low.

Procedure

Step 1 Hoist the RRU and mounting kits onto the tower, as shown in [Figure 6-1](#).

**NOTE**

Hoist mounting kits onto the tower and then install the mounting kits before hoisting the RRU onto the tower. When hoisting the mounting kits and RRU, protect them from colliding with the tower.

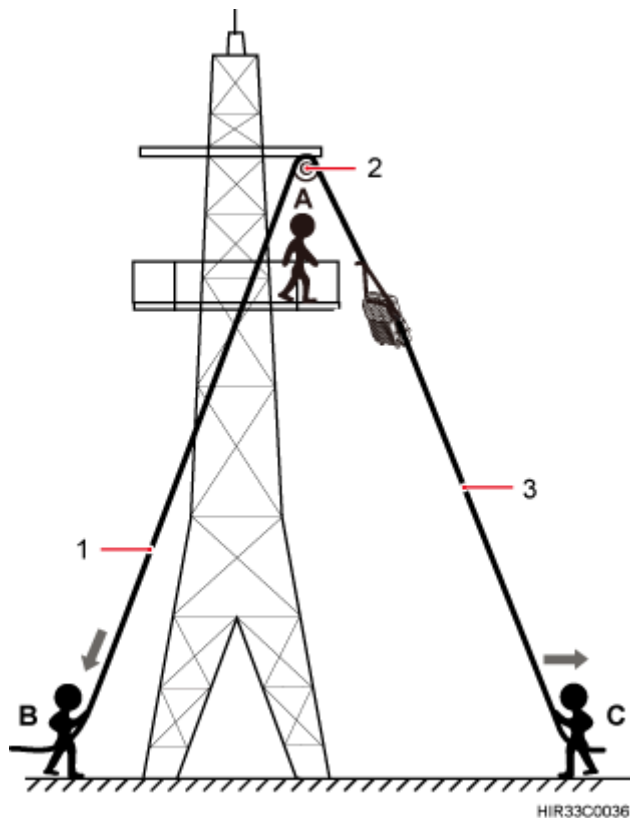
Figure 6-1 Hoisting an RRU onto a tower

(1) Lifting sling

(2) Fixed pulley

(3) Traction sling

1. After climbing up to the tower, installation engineer A secures the fixed pulley to the tower platform support and leads the lifting sling through the fixed pulley.
2. Installation engineer C binds the mounting kits using the lifting sling, as shown in [Figure 6-2](#), and binds the RRU using the lifting sling and traction sling, as shown in [Figure 6-3](#).

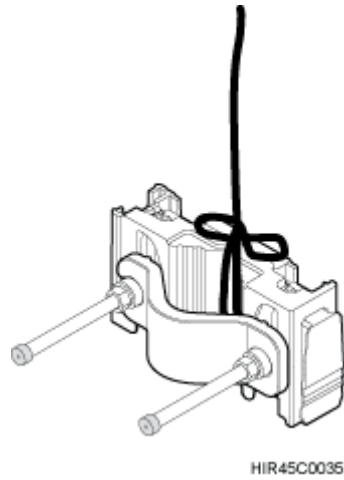
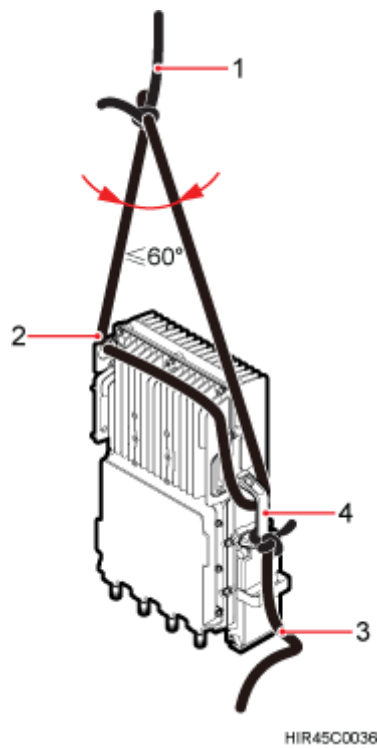
Figure 6-2 Binding mounting kits for the RRU**Figure 6-3** Binding the RRU

(1) Lifting sling

(2) Lifting eye

(3) Traction sling

(4) RRU handle

 **CAUTION**

- Each sling has a load-bearing capacity of more than 200 kg (441 lb), the diameter of the sling must be less than 25 mm (0.98 in.), and the angle at the top of the lifting sling [by the knot] must not be greater than 60 degrees.
- When hoisting the RRU and mounting kits onto the tower, protect them from colliding with the tower.
- Hoist the RRU onto the tower before it is installed on a pole, angle steel, or U-steel.
- Do not hoist the RRU by the handle or lifting eye only, as shown in [Figure 6-4](#) and [Figure 6-5](#).

Figure 6-4 Incorrect binding method - hoisting the RRU by the handle only

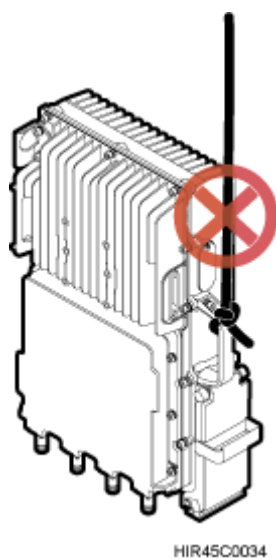
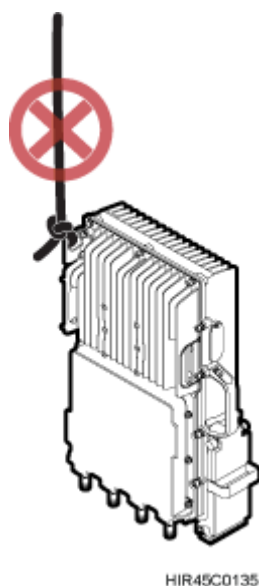

Figure 6-5 Incorrect binding method - hoisting the RRU by the lifting eye only

3. Installation engineer B pulls the lifting sling downwards, and installation engineer C pulls the traction sling outwards to protect the RRU from colliding with the tower.

Step 2 Installation engineer A catches the RRU and mounting kits and install the RRU.

Step 3 Remove the lifting sling and traction sling.

**NOTE**

The procedure for hoisting the RRU onto the tower is for your reference only.

----End

6.2 Hoisting Fiber Optic Cables onto a Tower

This section describes the procedure for hoisting fiber optic cables onto a tower and the precautions that must be taken.

Context

Cabling requirements for power cables are met. For details, see Cabling Requirements.

Procedure

- Step 1** Hoist the fiber optic cables onto the tower, as shown in [Figure 6-6](#).

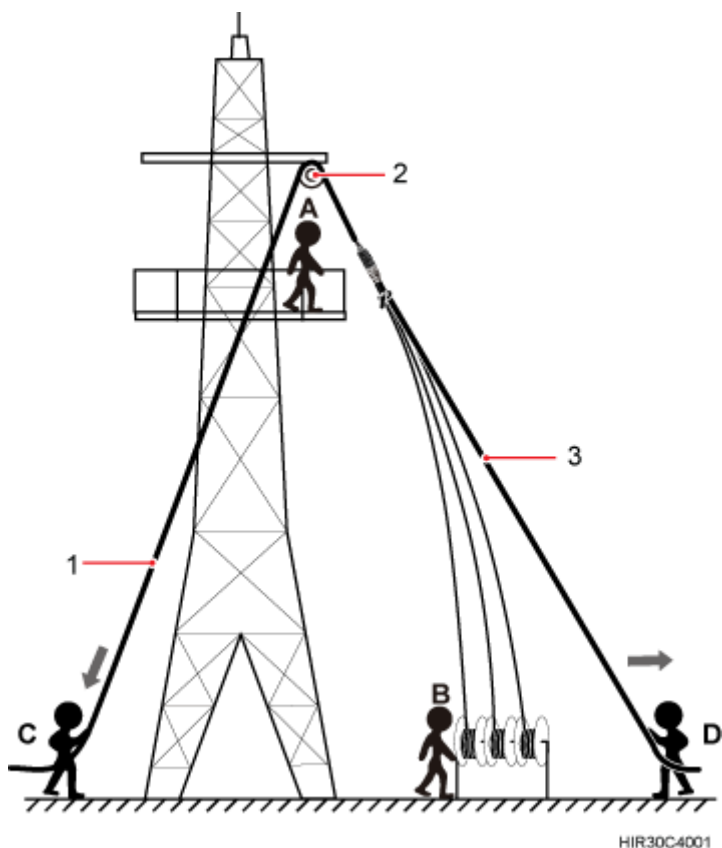
Figure 6-6 Hoisting fiber optic cables onto the tower

(1) Lifting sling

(2) Fixed pulley

(3) Traction sling

**CAUTION**

Before hoisting fiber optic cables onto the tower, connect the fiber optic cables to the RRU or BBU based on the labels on both ends of the cables and determine the hoisting direction.

1. After climbing up to the tower, installation engineer A secures the fixed pulley to the tower platform support and leads the lifting sling through the fixed pulley.
2. Installation engineer B places the fiber coiler for coiling fiber optic cables on the fiber spools, and installation engineer D lead the lifting sling through the stretch sling of the fiber optic cables and use the other sling as a traction sling to secure the cables 4 m (13.12 ft) away from the lifting sling, as shown in [Figure 6-7](#).

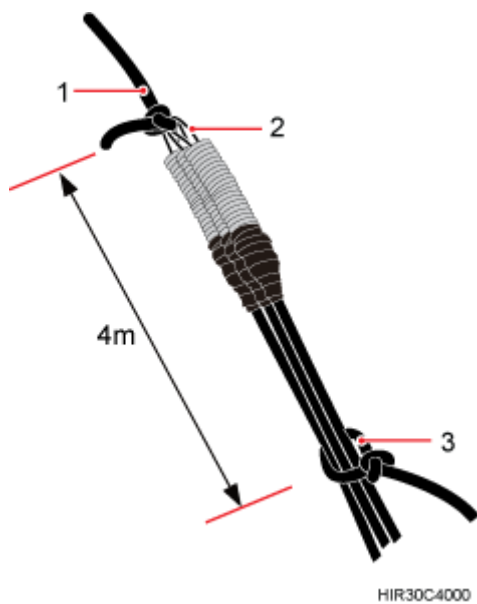
Figure 6-7 Binding fiber optic cables

(1) Lifting sling

(2) Stretch sling

(3) Traction sling

**CAUTION**

Do not remove the stretch sling and protection pipe or bind fiber optic cables using one sling, as shown in [Figure 6-8](#).

Figure 6-8 Incorrect binding method

- Installation engineer B rotates the fiber spools at the speed of 5 m (16.4 ft) to 15 m (49.21 ft) per minute to coil the fiber optic cables.

4. Installation engineer C pulls the lifting sling downwards, and installation engineer D pulls the traction sling outwards to protect the fiber optic cables from colliding with the tower.

Step 2 Secure the fiber optic cables to the tower vertically using cable clips.

Step 3 Remove the lifting sling, traction sling, and protection pipe.



NOTE

The procedure for hoisting the fiber optic cables onto the tower is for your reference only.

----End

6.3 Hoisting Power Cables onto a Tower

This section describes the procedure for hoisting power cables onto a tower and the precautions that must be taken.

Context

Cabling requirements for power cables are met. For details, see Cabling Requirements.

The procedure for adding a connector to the RRU power cable on the RRU side is done under the tower.

Procedure

- Step 1** Hoist the power cables onto the tower, as shown in [Figure 6-9](#).

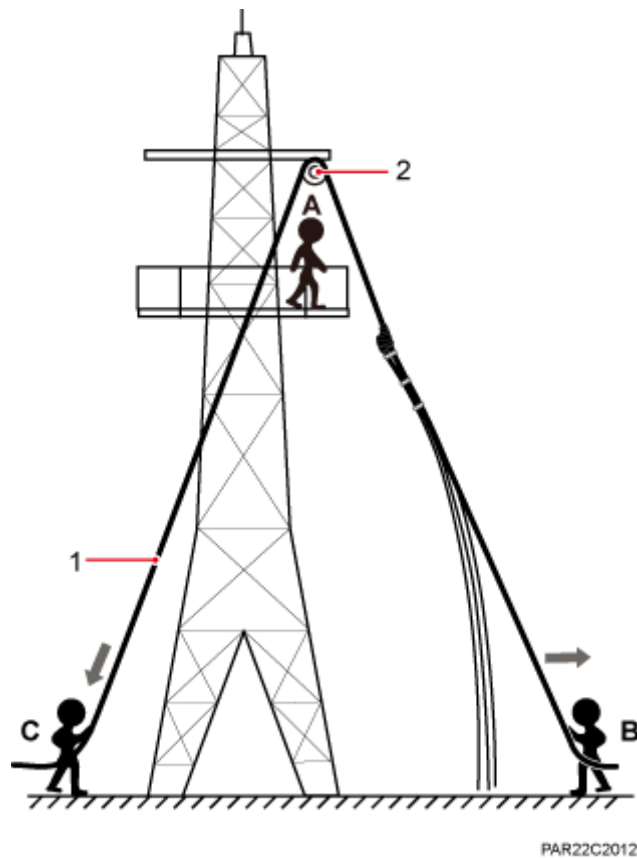
Figure 6-9 Hoisting power cables onto the tower

(1) Lifting sling

(2) Fixed pulley

1. After climbing up to the tower, installation engineer A secures the fixed pulley to the tower platform support and leads the lifting sling through the fixed pulley.
2. Installation engineer B secures three cable ties to the power cable connector, and then secures the power cable to the lifting sling, as shown in [Figure 6-10](#).

 **NOTE**

The connector on the power cable in the figure is only an example. The actual connector may vary according to the situation.

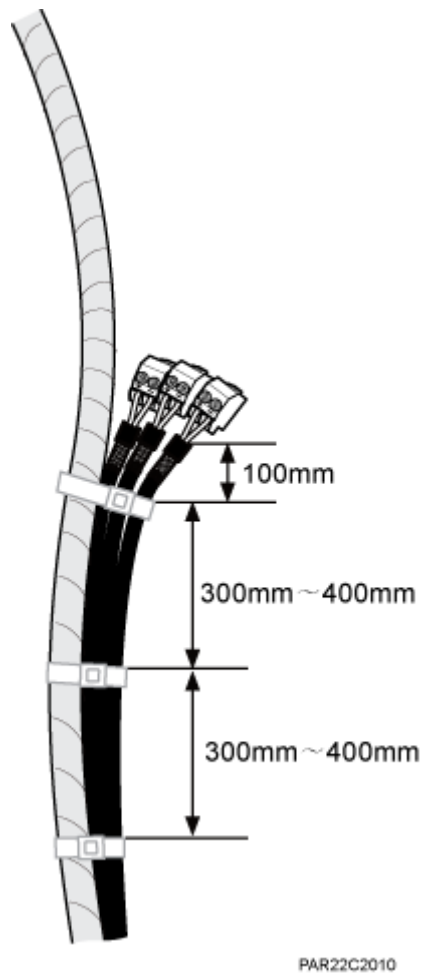
Figure 6-10 Binding cable ties

- Installation engineer B wraps the power cable connector with a layer of PVC insulation tape, as shown in [Figure 6-11](#).

**NOTE**

Wrap the PVC insulation tape from 30 mm (1.18 in.) away from one end of the connector until it reaches the other end of the connector. The total length of the wrapped connector is 100 mm (3.94 in.).

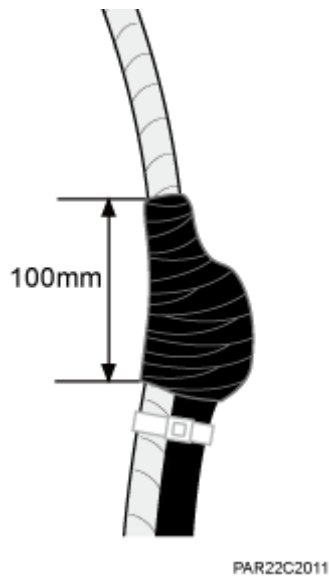
Figure 6-11 Wrapping the PVC insulation tape

4. Installation engineer C pulls the lifting sling downwards, and installation engineer B pulls the other end of the lifting sling outwards to protect the power cables from colliding with the tower.

Step 2 Secure the power cables to the tower vertically using cable clips.

Step 3 Remove the cable ties, PVC insulation tape, and lifting sling.

**NOTE**

The procedure for hoisting the power cables onto the tower is for your reference only.

----End

7 Installing the RRU

About This Chapter

This chapter describes the procedure for installing the RRU. The RRU can be installed on a pole, U-steel, angle steel, or wall as required.



CAUTION

- Do not stand the RRU upright because the load-bearing capacity of the RF ports at the RRU bottom is low.
 - Place a foam pad or cardboard under an RRU to protect the RRU housing from damage during the installation.
-

[7.1 Mounting Kits for an RRU](#)

This section describes the bracket assembly and the attachment plate for an RRU.

[7.2 Installing the RRU on a Pole](#)

This section illustrates the installation of one or more RRUs on a pole.

[7.3 Installing the RRU on U-Steel](#)

This section describes the procedure for installing the RRU on U-steel and the precautions that must be taken during the installation. The RRU installed on U-steel can be mounted to a tower or placed on the ground. It is recommended that only one RRU be installed on U-steel.

[7.4 Installing the RRU on Angle Steel](#)

This section describes the procedure for installing the RRU on angle steel and the precautions that must be taken during the installation. The RRU installed on angle steel can be mounted to a tower or placed on the ground. It is recommended that only one RRU be installed on angle steel.

[7.5 Installing the RRU on a Wall](#)

This section describes the procedure for installing the RRU on a wall and the precautions that must be taken during the installation.

7.1 Mounting Kits for an RRU

This section describes the bracket assembly and the attachment plate for an RRU.

Figure 7-1 shows the bracket assembly for an RRU.

Figure 7-1 Bracket assembly for an RRU

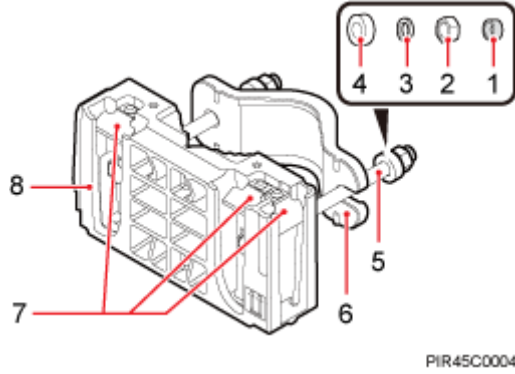

- | | | | |
|-----------------------|--------------------------------|--|---------------------------|
| (1) Plastic screw cap | (2) M10 nut | (3) Spring washer | (4) Flat washer |
| (5) M10x150 bolt | (6) Auxiliary mounting bracket | (7) Hoist clamp on the main mounting bracket | (8) Main mounting bracket |

Figure 7-2 shows the rear view of an RRU.

Figure 7-2 Rear view of an RRU

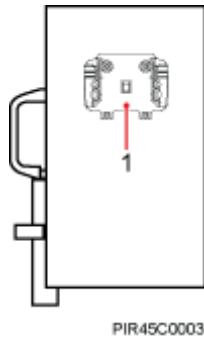

- (1) Attachment plate

7.2 Installing the RRU on a Pole

This section illustrates the installation of one or more RRUs on a pole.

Figure 7-3 shows a single RRU installed on a pole.

Figure 7-3 Single RRU installed on a pole

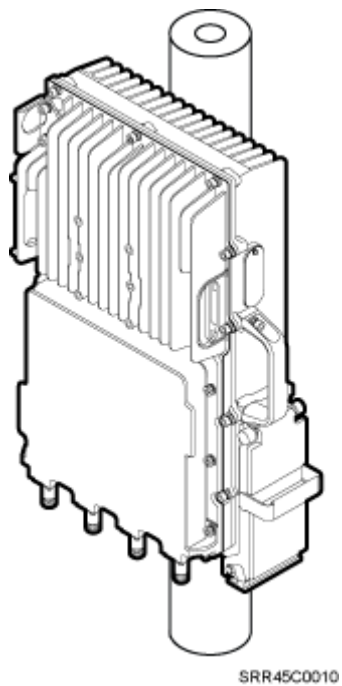
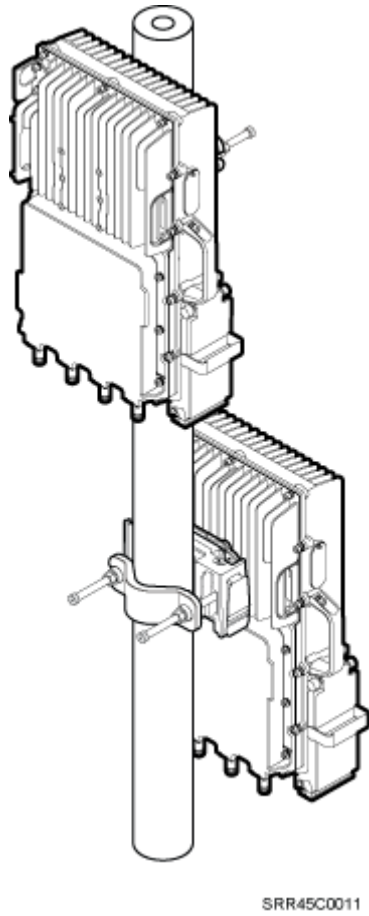

Figure 7-4 shows two RRUs installed on a pole.

Figure 7-4 Two RRUs installed on a pole**NOTE**

If two RRUs are installed on a pole, the minimum distance between the two sets of mounting kits is the height of an RRU.

[Figure 7-5](#), [Figure 7-6](#), and [Figure 7-7](#) show multiple RRUs installed on a pole.

Figure 7-5 Three RRUs installed on a pole in centralized mode

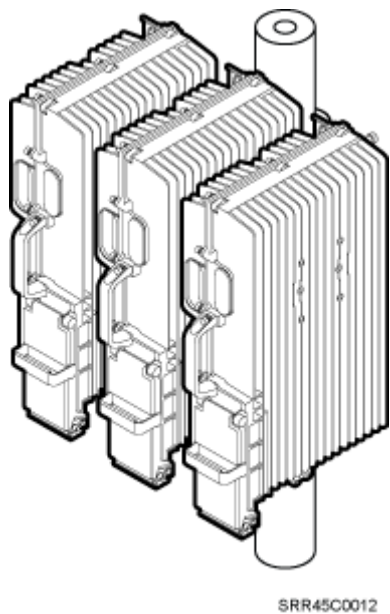
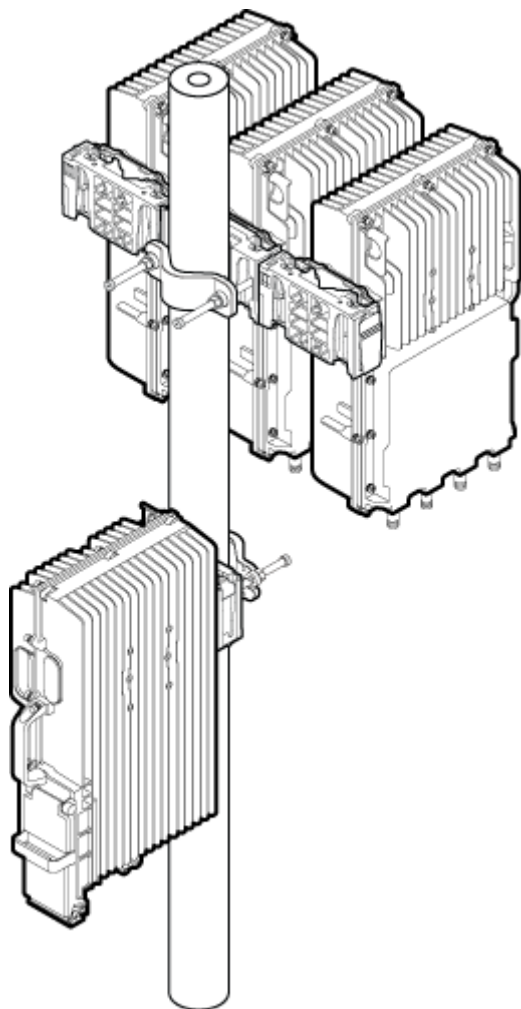
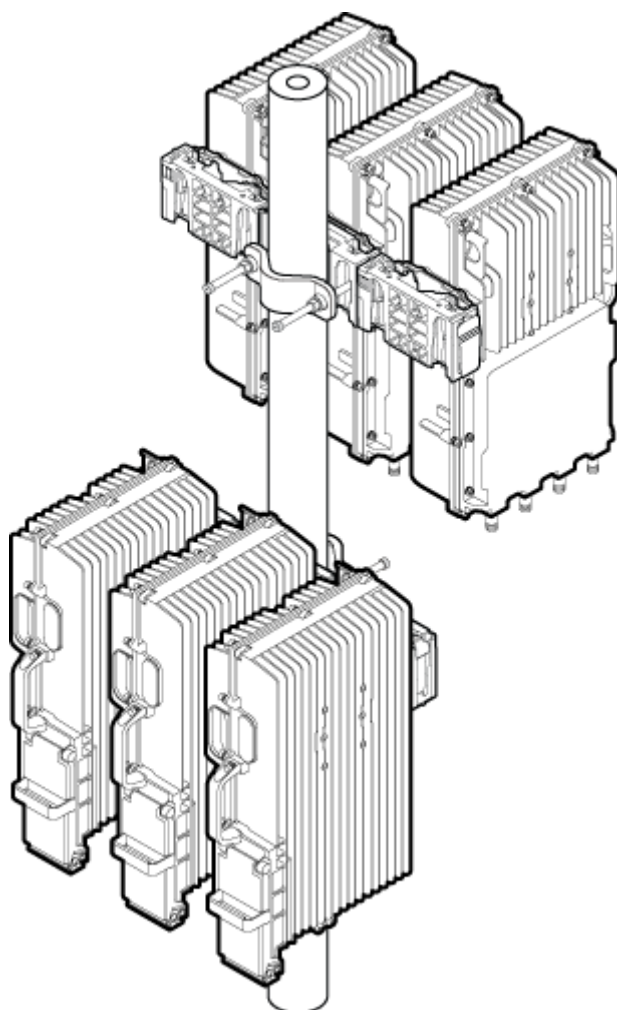

Figure 7-6 Four RRUs installed on a pole in centralized mode



SRR45C0013

Figure 7-7 Six RRUs installed on a pole in centralized mode

SRR45C0014

7.2.1 Installing a Single RRU

This section describes the procedure for installing a single RRU on a pole and the precautions that must be taken during the installation.

Prerequisites

Before you install an RRU on a tower, the RRU and mounting kits are hoisted onto the tower. For details, see [6.1 Installing an RRU on a Tower](#).

The hoist clamp on the main mounting bracket is secured properly.

Procedure

Step 1 Determine a position for installing the main mounting bracket.

- If the RRU must be installed on a tower, see [3.5.1 Clearance for a Single RRU](#) to determine a position.

- If the RRU must be installed on the ground, see [Figure 7-8](#) to determine a position.

Figure 7-8 Distance between the main mounting bracket and the ground

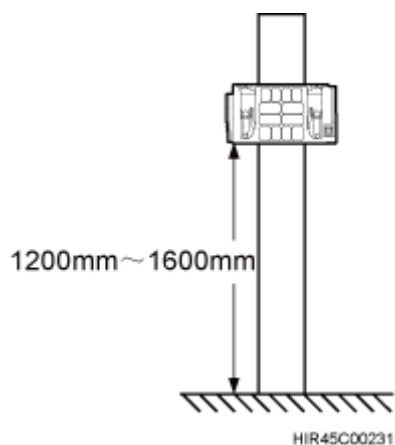

- Step 2** Manually loosen the two M10 nuts on the mounting kits counterclockwise, horizontally remove one end of the M10x150 bolt from the U notch on the auxiliary mounting bracket, and then disassemble the mounting kits, as shown in [Figure 7-9](#).

Figure 7-9 Removing the M10x150 bolt from the U notch

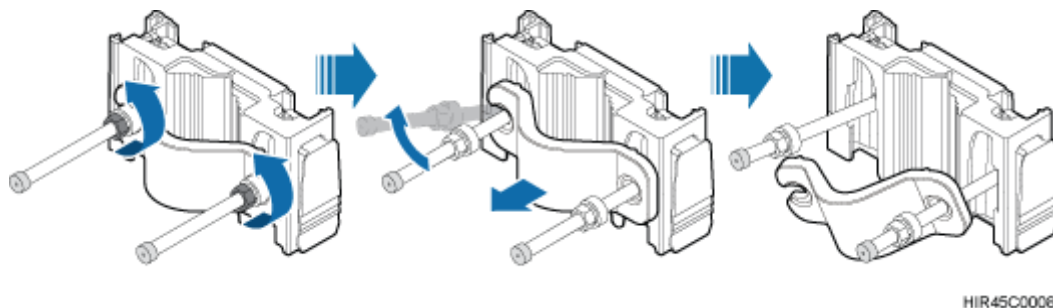

- Step 3** Install the bracket assembly on a pole. Then, place the removed end of the bolt into the U notch, as shown in [Figure 7-10](#).

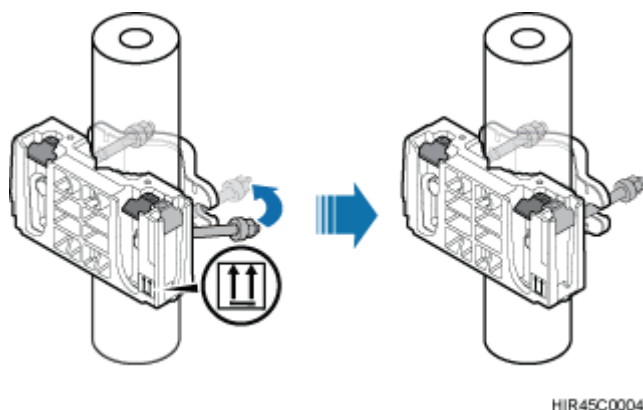
Figure 7-10 Bracket assembly installed on a pole

Step 4 To secure the bracket assembly to the pole, use a torque wrench with an aperture of 16 mm (0.67 in.) to tighten the two M10 nuts with a torque of 40 N·m (354.03 lbf·in.), as shown in Figure 7-11.

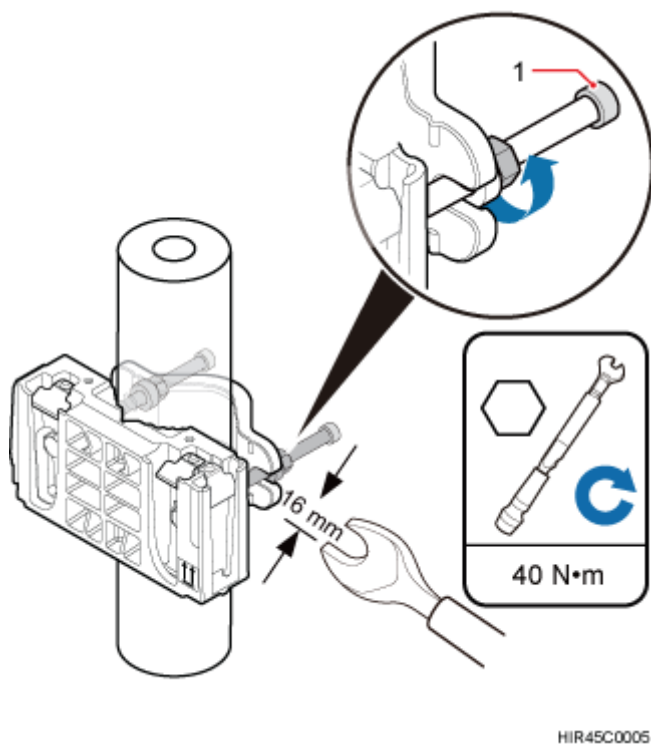
Figure 7-11 Securing the bracket assembly

(1) Plastic screw cap

NOTE

Do not remove the plastic screw caps from the bolts on the mounting kits.

Step 5 Install the RRU on the main mounting bracket until the RRU snaps shut, as shown in Figure 7-12.

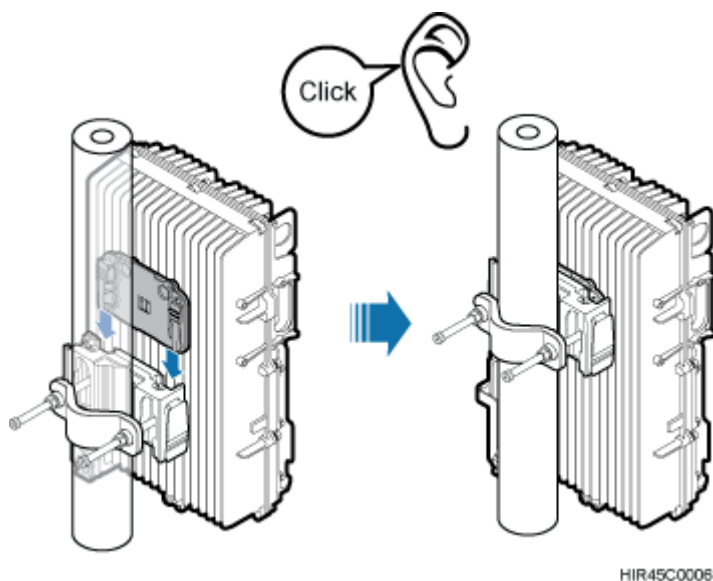
Figure 7-12 Installing the RRU on the main mounting bracket

----End

7.2.2 Installing Two RRUs

This section describes the procedure for installing two RRUs on a pole and the precautions that must be taken during the installation.

Procedure

Step 1 Install the first RRU, as shown in [Figure 7-13](#). For details, see [7.2.1 Installing a Single RRU](#).

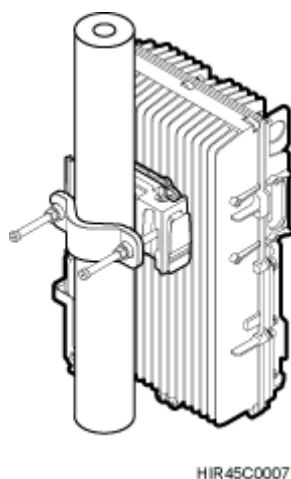
Figure 7-13 Installing the first RRU

Step 2 Install the second set of mounting kits, The distance between the two sets of mounting kits must equal the height of an RRU.

- Step 3** Remove the attachment plate from the rear of the second RRU and then install it on the RRU front, as shown in [Figure 7-14](#).

Figure 7-14 Removing the attachment plate from the rear of the second RRU and then installing it on the RRU front

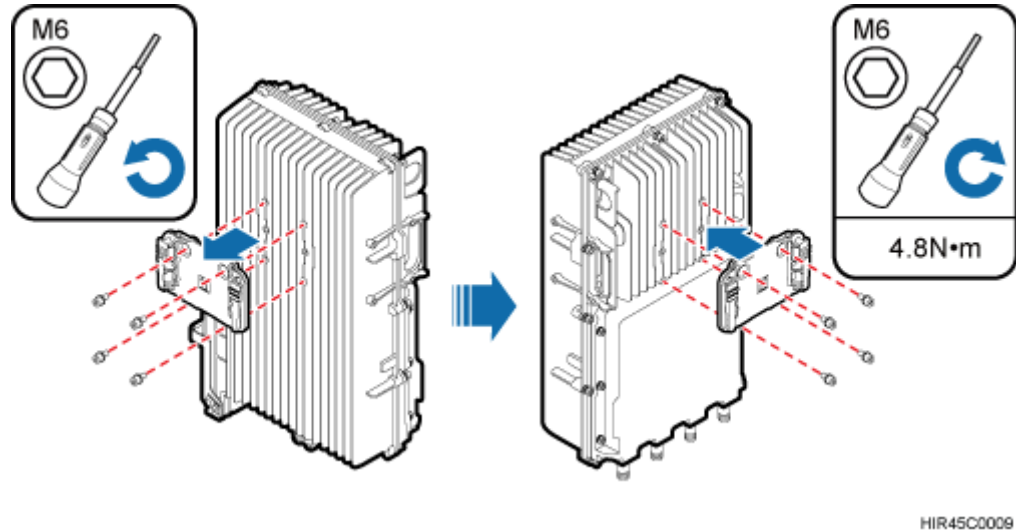

1. Remove the attachment plate from the RRU rear using an inner hexagon screwdriver.
2. Install the attachment plate to the RRU front, and tighten the stainless steel screws on the attachment plate with a torque of 4.8 N·m (44.25 lbf·in.) using a torque screwdriver.

- Step 4** Install the second RRU on the main mounting bracket, as shown in [Figure 7-15](#).

NOTE

When you install two RRUs in back-to-back mode, ensure that the cabling cavities of these two RRUs face the same direction.

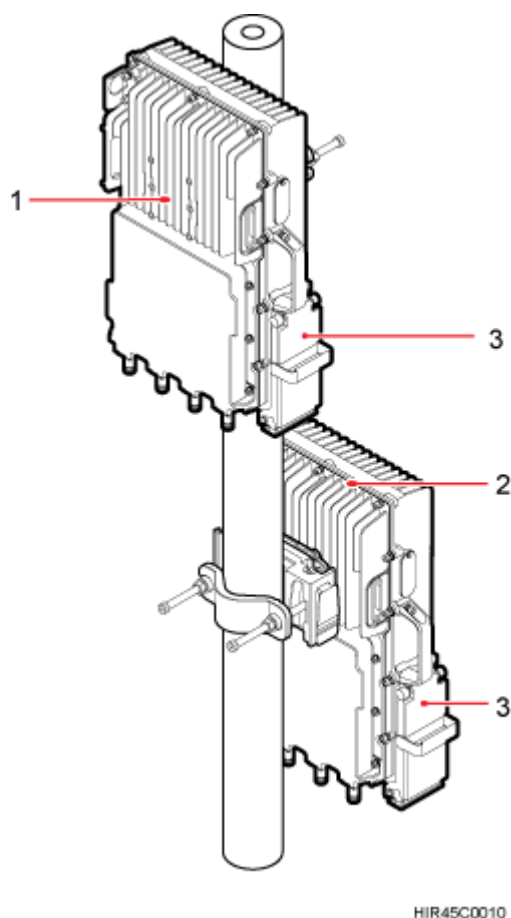
Figure 7-15 Installing the second RRU on the main mounting bracket

(1) RRU installed in standard mode

(2) RRU installed in reverse mode

(3) Cabling cavity

----End

7.2.3 Installing Multiple RRUs

This section describes the procedure for installing multiple remote radio units (RRUs) on a pole and the precautions that must be taken during the installation.

Context

Three, four, or six RRUs can be installed on a pole. The procedures for installing them are the same. Following is the procedure for installing four RRUs on a pole.

Procedure

- Step 1** Install the first set of mounting kits on a pole. For details, see [7.2.1 Installing a Single RRU](#).
- Step 2** Remove an attachment plate from the RRU rear, and install it on one side of the RRU, as shown in [Figure 7-16](#). (Repeat this step to change the positions of all the other attachment plates of the RRU.)

Figure 7-16 Removing an attachment plate from the RRU rear and installing it on one side of the RRU

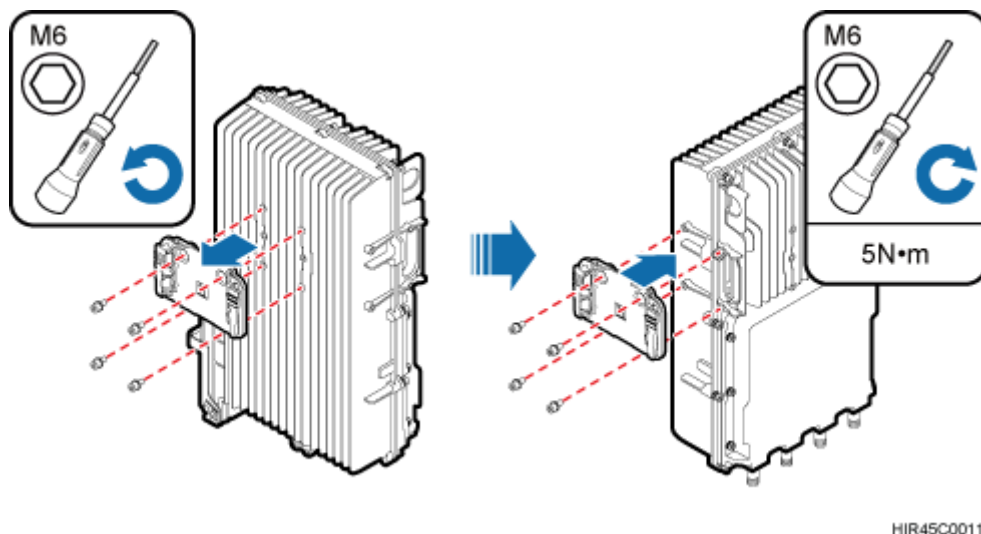

1. Use an inner hexagon screwdriver to remove the attachment plate from the RRU rear.
2. Install the attachment plate on one side of the RRU, and use a torque screwdriver to tighten the stainless steel screws on the attachment plate with a torque of 5 N·m (44.25 lbf·in.).

Step 3 Install the first RRU on the main mounting bracket in the first set of mounting kits, as shown in [Figure 7-17](#).

Figure 7-17 Installing the first RRU on the main mounting bracket

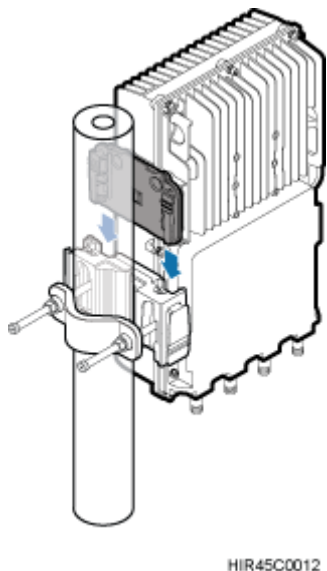

Step 4 Install the second main mounting bracket on the side of the first main mounting bracket, as shown in [Figure 7-18](#).

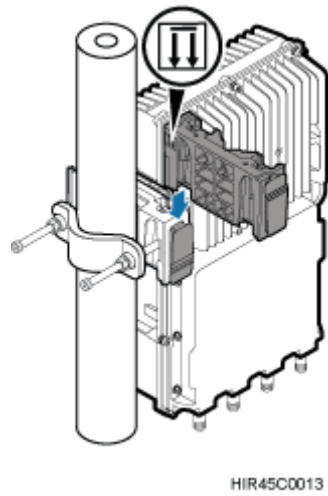
Figure 7-18 Installing the second main mounting bracket

Step 5 Install the second RRU on the second main mounting bracket, as shown in [Figure 7-19](#).

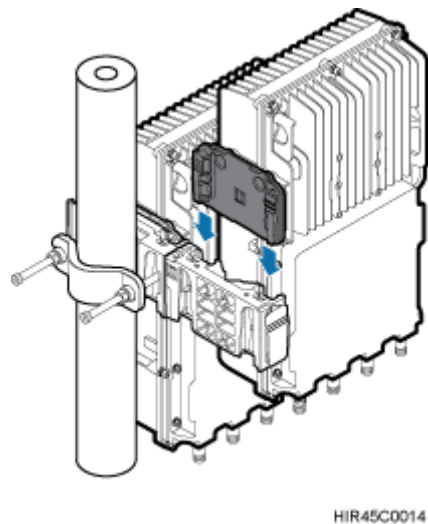
Figure 7-19 Installing the second RRU on the main mounting bracket

Step 6 Install the third main mounting bracket and the third RRU, as shown in [Figure 7-20](#).

Figure 7-20 Installing the third RRU on the main mounting bracket

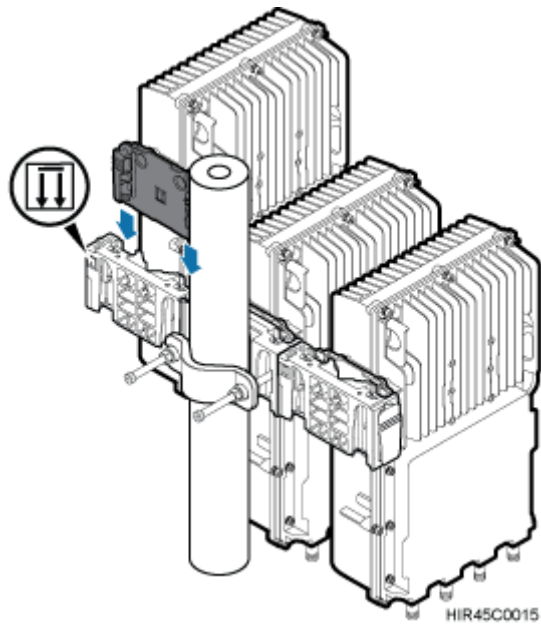

Step 7 Install the second set of mounting kits, as shown in [Figure 7-21](#). The minimum distance between the two sets of mounting kits is the height of an RRU.

Figure 7-21 Installing the second set of mounting kits

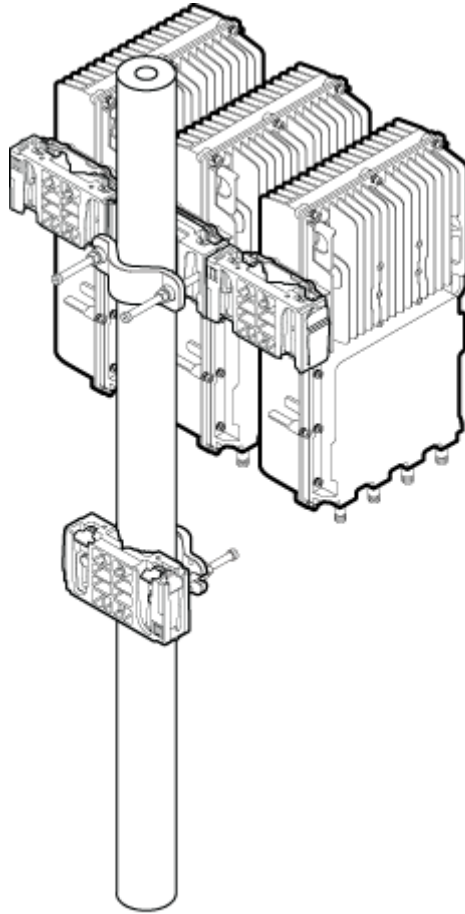

HIR45C0116

Step 8 Install the fourth RRU on the main mounting bracket of the second set of mounting kits, as shown in [Figure 7-22](#).

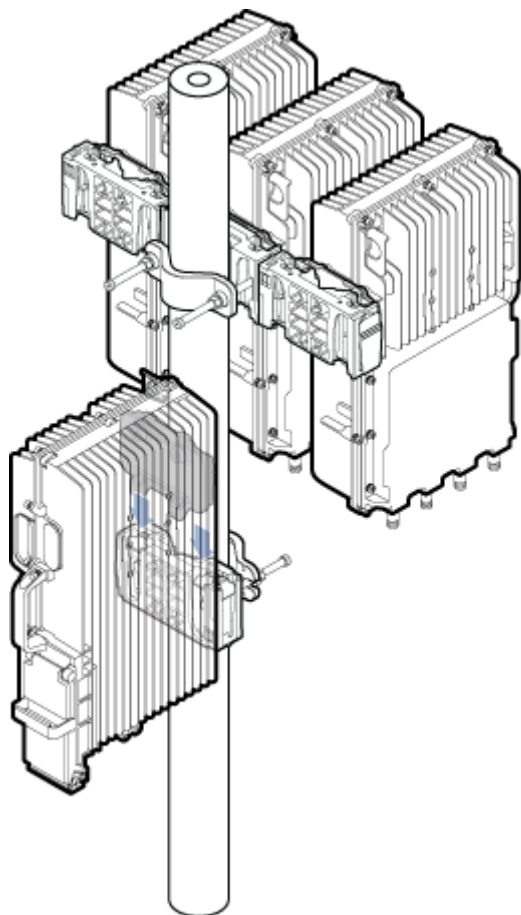
Figure 7-22 Installing the fourth RRU on the main mounting bracket

HIR45C0017

---End

7.3 Installing the RRU on U-Steel

This section describes the procedure for installing the RRU on U-steel and the precautions that must be taken during the installation. The RRU installed on U-steel can be mounted to a tower or placed on the ground. It is recommended that only one RRU be installed on U-steel.

Prerequisites

Before you install an RRU on a tower, the RRU and mounting kits are hoisted onto the tower. For details, see [6.1 Installing an RRU on a Tower](#).

The hoist clamp on the main mounting bracket is secured properly.

Context

[Figure 7-23](#) shows the top view of the RRU installed on angle steel.

Figure 7-23 Top view of the RRU

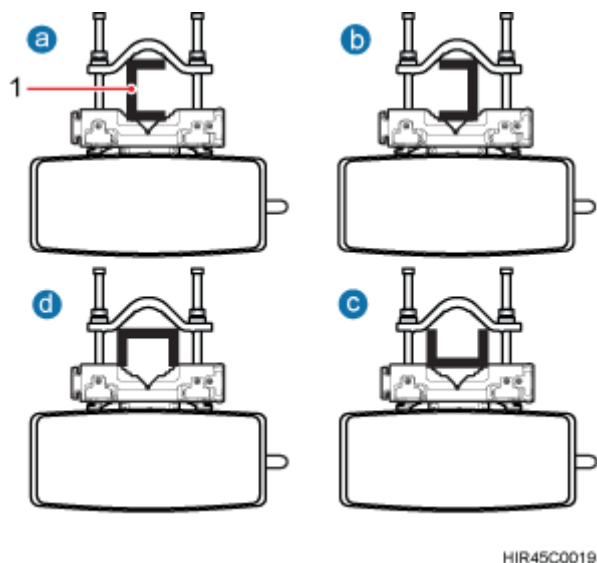

(1) U-steel

NOTE

If the length of the narrow side of U-steel is less than 40 mm (1.57 in.), install an RRU in mode a or mode b shown in [Figure 7-23](#).

Procedure

Step 1 Determine a position for installing the main mounting bracket.

- If the RRU is to be installed on a tower, determine the position for installing the main mounting bracket by referring to [3.5.1 Clearance for a Single RRU](#).
- If the RRU is to be installed on the ground, determine the position for installing the main mounting bracket by referring to [Figure 7-24](#).

Figure 7-24 Distance between the main mounting bracket and the ground

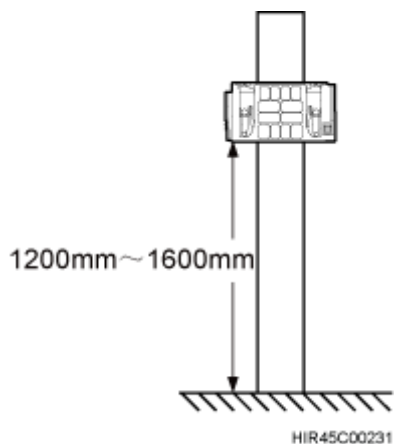

 **NOTE**

It is recommended that the main mounting bracket be 1200 mm to 1600 mm (47.24 in. to 62.99 in.) above the ground.

- Step 2** Manually loosen the two M10 nuts on the mounting kits counterclockwise, horizontally remove one end of the M10x150 bolt from the U notch on the auxiliary mounting bracket, and then disassemble the mounting kits, as shown in [Figure 7-25](#).

Figure 7-25 Removing the M10x150 bolt from the U notch

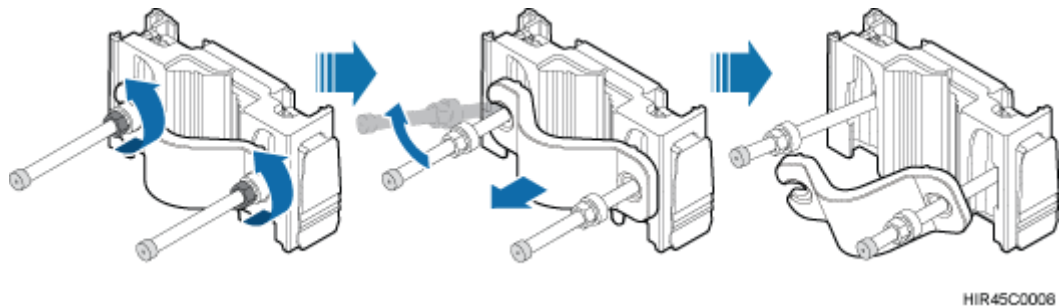

- Step 3** Install the bracket assembly on U-steel. Then, place the removed end of the bolt into the U notch, as shown in [Figure 7-26](#).

Figure 7-26 Bracket assembly installed on U-steel

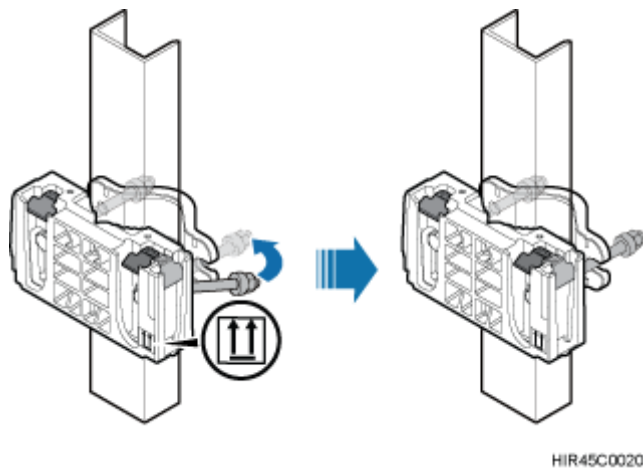

- Step 4** To secure the bracket assembly to the U-steel, use a torque wrench with an aperture of 16 mm (0.67 in.) to tighten the two M10 nuts with a torque of 40 N·m (354.03 lbf·in.), as shown in [Figure 7-27](#).

Figure 7-27 Securing the bracket assembly

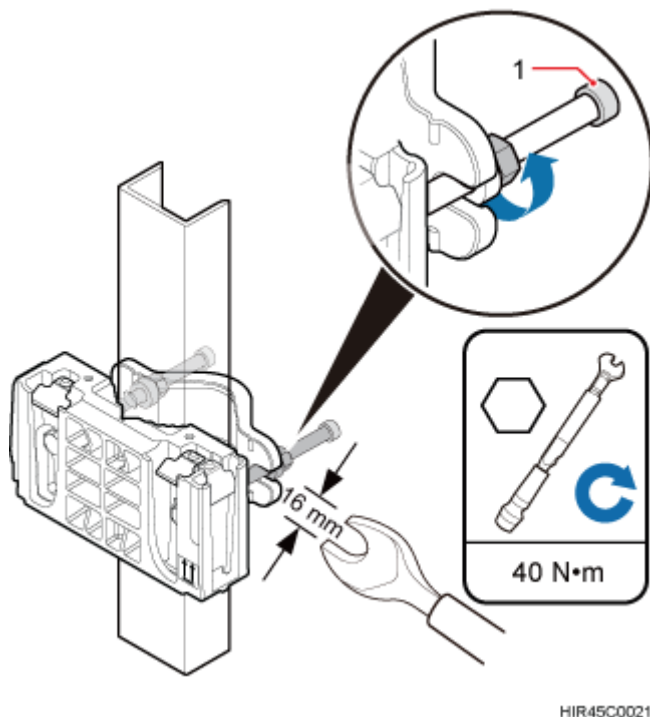

(1) Plastic screw cap

Step 5 Install the RRU on the main mounting bracket until the RRU snaps shut, as shown in [Figure 7-28](#).

Figure 7-28 Installing the RRU on the main mounting bracket

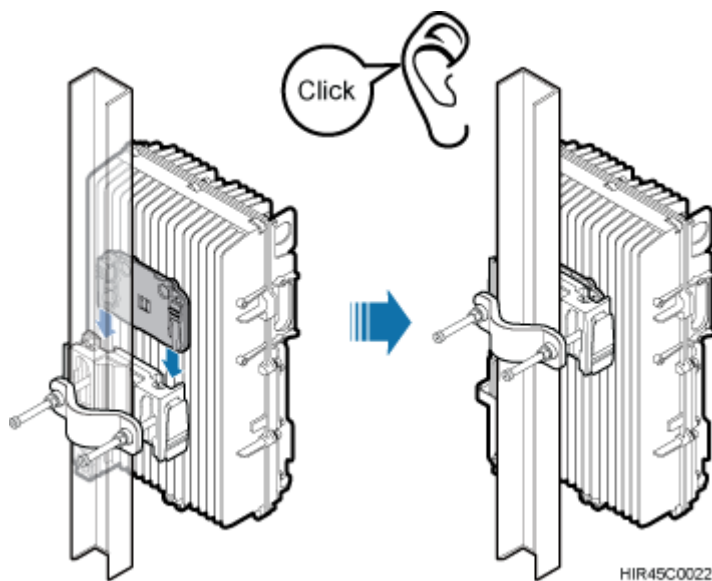

----End

7.4 Installing the RRU on Angle Steel

This section describes the procedure for installing the RRU on angle steel and the precautions that must be taken during the installation. The RRU installed on angle steel can be mounted to a tower or placed on the ground. It is recommended that only one RRU be installed on angle steel.

Prerequisites

Before you install an RRU on a tower, the RRU and mounting kits are hoisted onto the tower. For details, see [6.1 Installing an RRU on a Tower](#).

The hoist clamp on the main mounting bracket is secured properly.

Context

[Figure 7-29](#) shows the top view of the RRU installed on angle steel.

Figure 7-29 Top view of the RRU

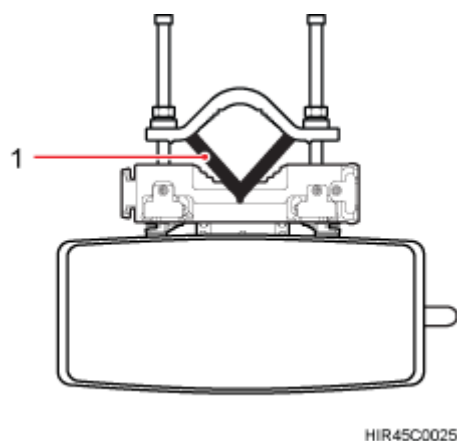

(1) Angle steel

Procedure

Step 1 Determine a position for installing the main mounting bracket.

- If the RRU is to be installed on a tower, determine the position for installing the main mounting bracket by referring to [3.5.1 Clearance for a Single RRU](#).
- If the RRU is to be installed on the ground, determine the position for installing the main mounting bracket by referring to [Figure 7-30](#).

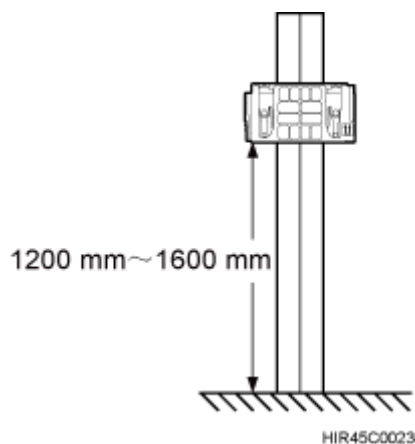
Figure 7-30 Distance between the main mounting bracket and the ground**NOTE**

It is recommended that the main mounting bracket be 1200 mm to 1600 mm (47.24 in. to 62.99 in.) above the ground.

- Step 2** Manually loosen the two M10 nuts on the mounting kits counterclockwise, horizontally remove one end of the M10x150 bolt from the U notch on the auxiliary mounting bracket, and then disassemble the mounting kits, as shown in [Figure 7-31](#).

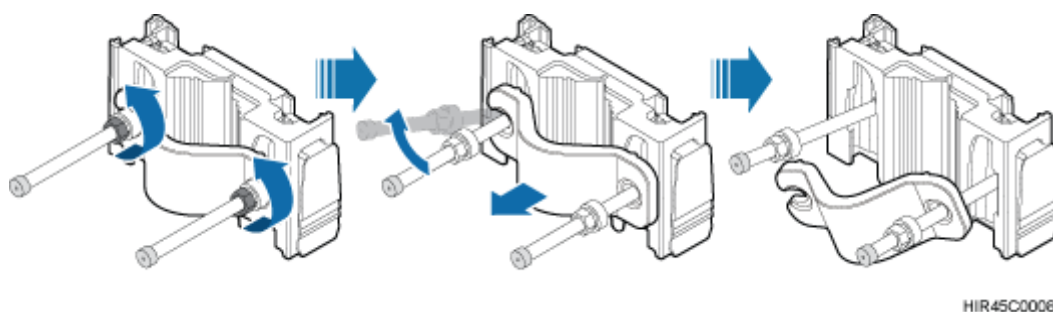
Figure 7-31 Removing the M10x150 bolt from the U notch

- Step 3** Install the bracket assembly on angle steel. Then, place the removed end of the bolt into the U notch, as shown in [Figure 7-32](#).

Figure 7-32 Bracket assembly installed on angle steel

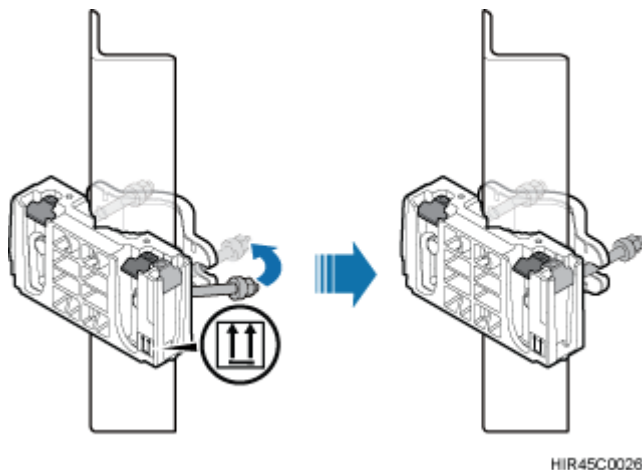

Step 4 To secure the bracket assembly to the angle steel, use a torque wrench with an aperture of 16 mm (0.67 in.) to tighten the two M10 nuts with a torque of 40 N·m (354.03 lbf·in.), as shown in [Figure 7-33](#).

Figure 7-33 Securing the bracket assembly

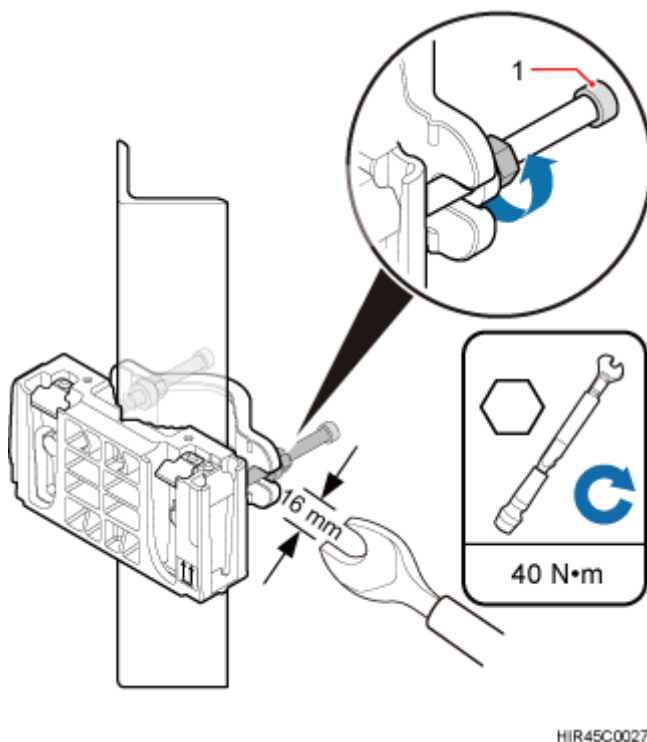

(1) Plastic screw cap

Step 5 Install the RRU on the main mounting bracket until the RRU snaps shut, as shown in [Figure 7-34](#).

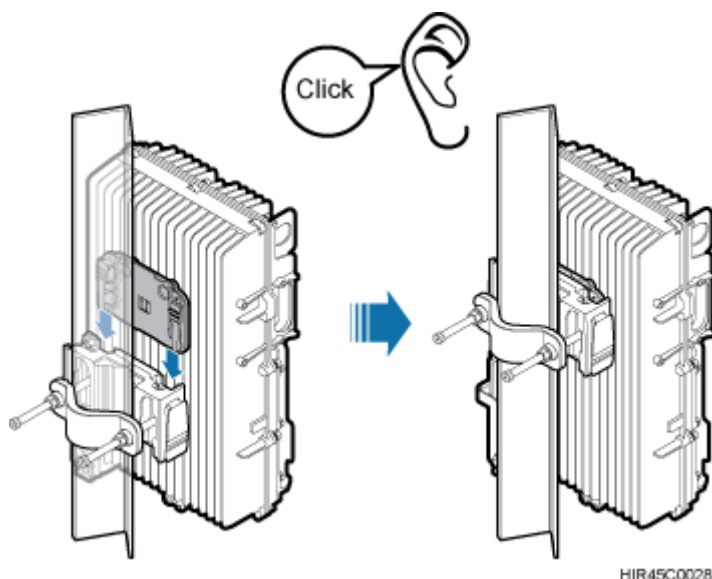
Figure 7-34 Installing the RRU on the main mounting bracket

----End

7.5 Installing the RRU on a Wall

This section describes the procedure for installing the RRU on a wall and the precautions that must be taken during the installation.

Prerequisites

The hoist clamp on the main mounting bracket is secured properly.

Context

The wall on which RRUs are installed must meet the following requirements:

- When a single RRU is installed, the wall has a capacity of bearing at least four times the weight of the RRU.
- Expansion bolts must be tightened with a torque of 15 N·m (265.52 lbf·in.) to ensure the bolts work properly and the wall remains intact without cracks in it.

Procedure

- Step 1** Remove the plastic screw caps, M10 nuts, spring washers, flat washers, auxiliary brackets, and M10x150 bolts in sequence. Then, use the main mounting bracket to secure the RRU to a wall.
- Step 2** Place the main mounting bracket against the installation position, use a level to verify that the main mounting bracket is placed horizontally, and then mark anchor points with a marker, as shown in [Figure 7-35](#).

Figure 7-35 Marking the anchor points

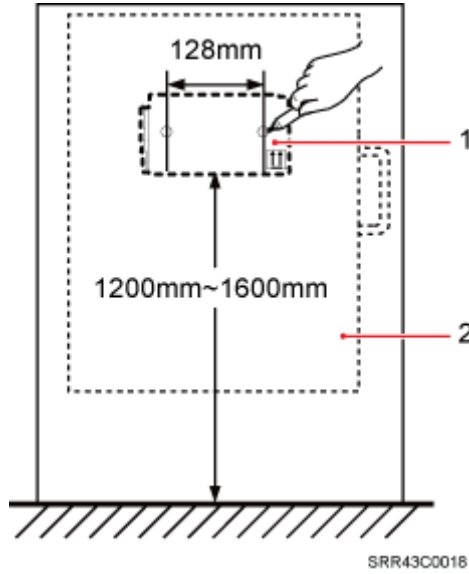

(1) Main mounting bracket

(2) RRU

NOTE

It is recommended that the main mounting bracket be 1200 mm to 1600 mm (47.24 in. to 62.99 in.) above the ground.

Figure 7-36 Expansion bolt assembly

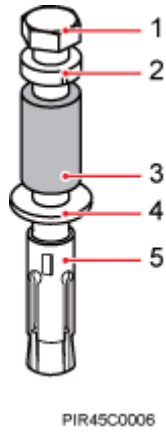

(1) M8x85 bolt

(2) Spring washer 8

(3) Plastic tube

(4) Flat washer 8

(5) Expansion tube

Step 3 Drill holes at the anchor points, and then install expansion bolt assemblies, as shown in [Figure 7-37](#).

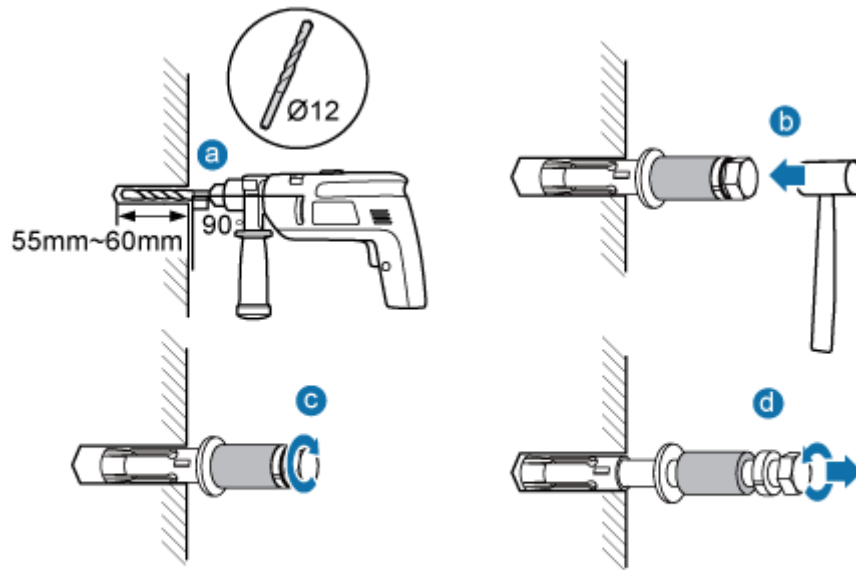
Figure 7-37 Drilling a hole and installing an expansion bolt assembly

HIR45C0029

1. Use a hammer drill with a $\phi 12$ bit to drill holes vertically at the marked anchor points. Ensure that the depth of each hole ranges from 55 mm to 60 mm (2.17 in. to 2.36 in.).

**WARNING**

Take proper safety measures to protect your eyes and respiratory tract against the dust before drilling holes.

2. Vertically insert the M8x85 expansion bolts into the mounting holes and use a rubber mallet to knock them until they are buried in the holes.
3. Partially tighten the expansion bolts clockwise.
4. Loosen the expansion bolts counterclockwise and then remove the M8x85 expansion bolts, spring washers, plastic tubes, and flat washers in sequence.

**NOTE**

After completely removing an expansion bolt, store the plastic tube properly.

- Step 4** Use the two removed M8x85 expansion bolts to secure the main mounting brackets to the wall. Then, use a torque socket to tighten the nuts of the expansion bolts with a torque of 15 N·m (265.52 lbf·in.), as shown in [Figure 7-38](#).

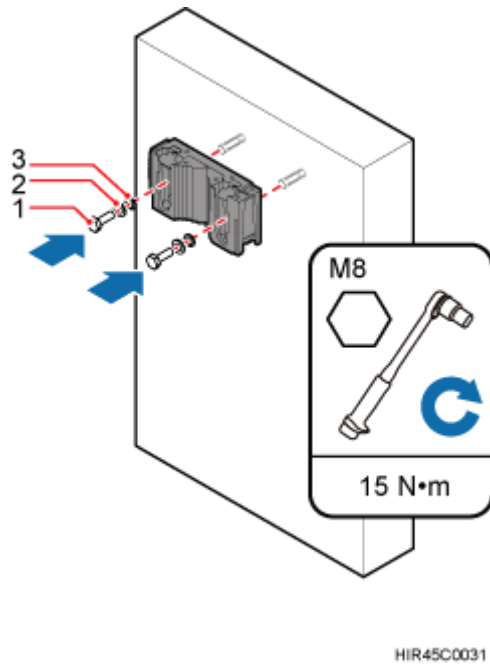
Figure 7-38 Securing the main mounting bracket to a wall

(1) M8x85 expansion bolts	(2) Spring washers	(3) Flat washers
---------------------------	--------------------	------------------

Step 5 Install the RRU on the main mounting bracket until the RRU snaps shut, as shown in [Figure 7-39](#).

Figure 7-39 Installing the RRU

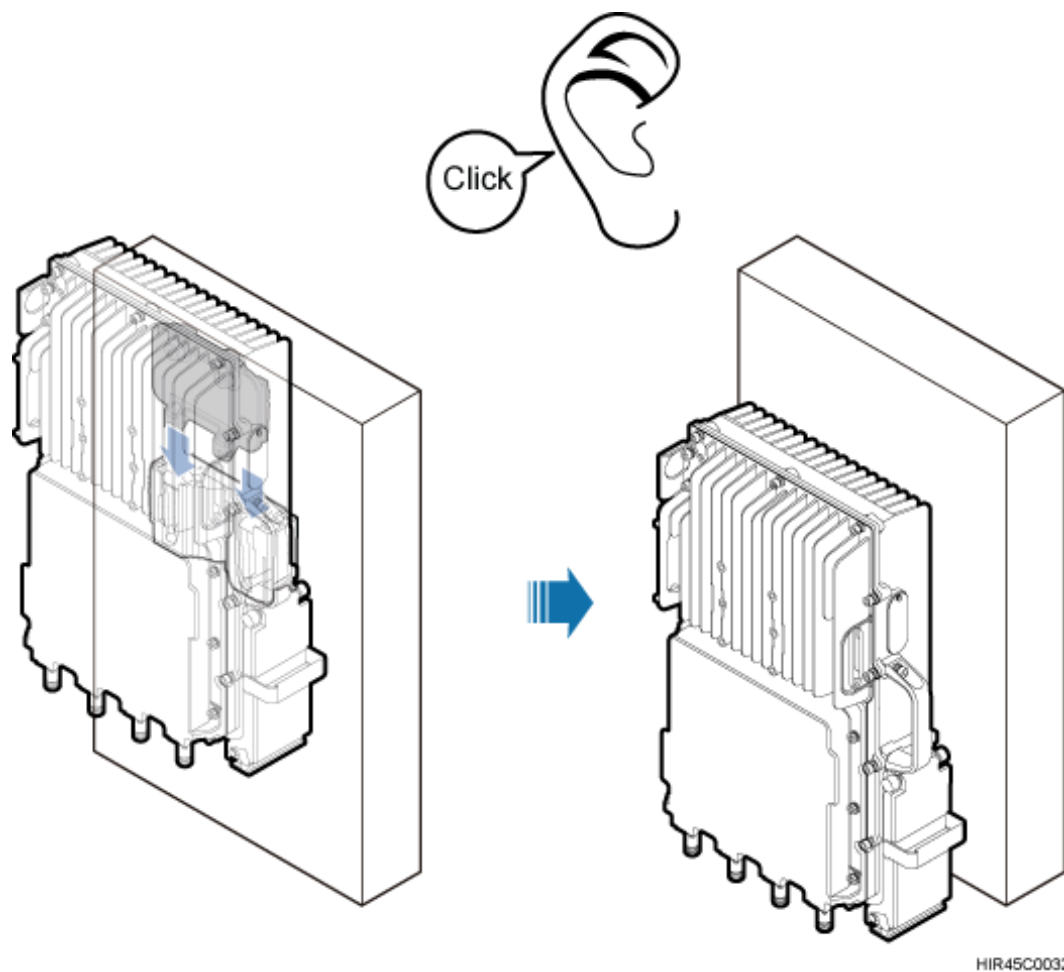

----End

8 Installing RRU Cables

About This Chapter

This chapter describes the procedure for installing RRU cables.

8.1 Cabling Requirements

Cables must be routed according to the specified cabling requirements to prevent signal interference.

8.2 Cable Connections

This section describes the cable connections for a single RRU and multiple RRUs.

8.3 Installation Process

This section describes the process of installing RRU cables.

8.4 RRU Cable List

This section describes RRU cable connections.

8.5 Installing an RRU PGND Cable

This section describes the procedure for installing an RRU PGND cable.

8.6 Installing an RRU RF Jumper

This section describes the procedure for installing an RRU RF jumper.

8.7 Installing an RRU Alarm Cable

This section describes the procedure for installing an RRU alarm cable.

8.8 Installing an RRU AISG Multi-Wire Cable and an RRU AISG Extension Cable

This section describes the procedures for installing an RRU AISG multi-wire cable and an RRU AISG extension cable.

8.9 Opening the Cover Plate of an RRU Cabling Cavity

This section describes the procedure for opening the cover plate of an RRU cabling cavity.

8.10 Installing an RRU Power Cable

This section describes the procedure for installing an RRU power cable.

8.11 Installing an Optical Fiber Cable

This section describes the procedure for installing an optical fiber cable.

8.12 Closing the Cover Plate of an RRU Cabling Cavity

This section describes the procedure for closing the cover plate of an RRU cabling cavity.

8.1 Cabling Requirements

Cables must be routed according to the specified cabling requirements to prevent signal interference.



NOTE

If a cable listed below is not required, skip the routing requirements of the cable.

General Cabling Requirements

Requirements for Bending Radius

- The bending radius of the 7/8" feeder must be more than 250 mm (9.84 in.), and the bending radius of the 5/4" feeder must be more than 380 mm (14.96 in.).
- The bending radius of the 1/4" jumper, ordinary 1/2" jumper, super-flexible 1/2" jumper, and RG-8U jumper must be more than 35 mm (1.38 in.), 127 mm (5 in.), 50 mm (1.97 in.), and 50 mm (1.97 in.), respectively.
- The bending radius of the power cable or PGND cable must be at least three times the diameter of the cable.
- The bending radius of a fiber optic cable is at least 20 times the diameter of the fiber optic cable, and the minimum bending radius of the breakout cable at each end of the fiber optic cable is 30 mm (1.18 in.).
- The bending radius of the E1/T1 cable must be at least three times the diameter of the cable.
- The bending radius of the signal cable must be at least five times the diameter of the cable.

Requirements for Cable Binding

- The same types of cable must be bound together.
- Different types of cable must be separately routed with the minimum spacing of 30 mm (1.18 in.) and cannot be entangled.
- The cables must be bound tightly and neatly. The sheaths of the cables must not be damaged.
- Cable ties are installed in the same direction, and those at the same horizontal line must be in a straight line.
- The excess of indoor cable ties is trimmed off, and the excess of outdoor cable ties allows about 5 mm (0.2 in.), without remaining rough edges.
- Labels or nameplates must be attached to both ends, joints, or turns of cables after they are installed.

Security Requirements

- Cables should be placed away from sharp objects or wall burrs. If these positions are inevitable, protect the cables with protection pipes.

- Cables must be routed away from heat sources, or heat-insulation materials are added between cables and heat sources.
- Sufficient slack (recommended for about 0.1 m [0.33 ft.]) is provided in cables at turns or the position close to a device, facilitating cable and device maintenance.

Indoor Cabling Requirements

- Cables are routed indoors through the feeder window.
- Drip loops must be made outside the feeder window, and the requirements for the minimum bending radius are met.
- When cables are routed indoors, engineers are required indoors for cooperation.
- The feeder window must be waterproofed.

Outdoor Cabling Requirements

- Cables routed outdoors must be led through a pipe when they may be damaged.
- AC power cables, transmission cables, and cables buried in the ground must be protected.
- If cables at the cabinet bottom need to be routed through a pipe along the ground, lead the pipe into the cabinet base for about 3 m (9.84 ft.) to 5 m (16.4 ft.), not into the cabinet. Block the pipe with waterproof tape or silicon gel, and secure the pipe to the cable hole at the cabinet bottom with metal piece.
- If cables at the cabinet bottom need to be routed through a pipe along the metal cable trough, do not lead the pipe into the cabinet base. The cable trough must be sealed and routed through the cable hole at the cabinet bottom.
- Cables are secured with cable clips.
- Cables are routed neatly along the specified cabling direction and secured with cable clips.
- The positions for cable clips are determined onsite. For example, the cable clips for the 7/8" feeder are installed at the spacing of 1.5 m (4.92 ft.) to 2 m (6.56 ft.) in the same direction, and the cable clips for the power cables are installed at the spacing of 1 m (3.28 ft.) to 1.5 m (4.92 ft.) in the same direction.
- Cable clips must be vertical with cables, and the cables in a cable clip must be parallel.
- After routing cables neatly and correctly, tighten the screws on cable clips.

Secure cables on the cable tray, as shown in [Figure 8-1](#).

Figure 8-1 Securing cables on the cable tray

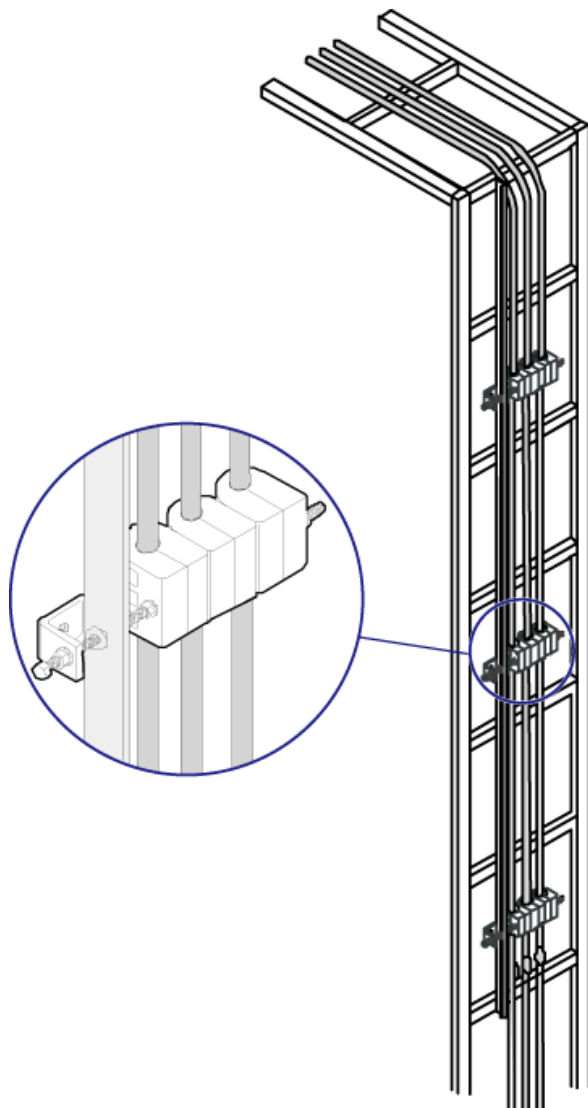

Secure cables on the tower, as shown in [Figure 8-2](#).

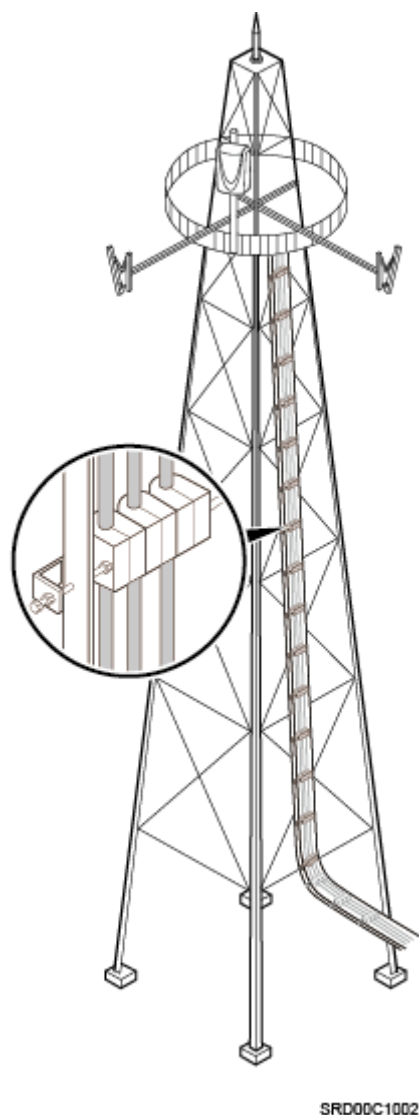
Figure 8-2 Securing cables on the tower

Special Cabling Requirements

Cabling Requirements for Power Cables

- Power cables must be installed in the position specified in engineering design documents.
- If the length of power cables is insufficient, replace the cables rather than adding connectors or soldering joints to lengthen the cables.
- Cables must be routed by only qualified and trained personnel before all preparations are made.
- Cables are routed in an untangled and orderly fashion.
- If DC power cables need to be routed on the tower platform, lay out the cables on the guardrail with the shortest distance and route the cables along the guardrail.

- If DC power cables need to be routed close to a device on the tower, secure the cables to the guardrail or pole with cable clips. The device cannot be far away from the position for securing the cables.

Cabling Requirements for PGND Cables

- PGND cables for the base station must be connected to the same ground bar.
- PGND cables must be buried in the ground or routed indoors. They should not be routed overhead before they are led into the equipment room.
- The exterior of the coaxial wire and the shield layer of the shielded cable must have proper electrical contact with the metal surface of the equipment to which they are connected.
- PGND cables and signal cables must be installed in an untangled and orderly fashion. A certain distance must be reserved between them to prevent interference from each other.
- Fuses or switches must not be installed on the PGND cables.
- Other devices must not be used for electrical connections of the PGND cables.
- All the metal parts in the housing of the equipment must be reliably connected to the ground terminal.

Cabling Requirements for E1 Cables

- E1 cables must not cross power cables, PGND cables, or RF cables when routed. If transmission cables are routed with power cables, PGND cables, or RF cables in parallel, the spacing between them must be greater than 30 mm (1.18 in.).
- E1 cables are routed straightly and bound neatly with cable ties.
- Sufficient slack is provided in E1 cables at turns.
- E1 cables cannot be squeezed by the cabinet door when routed through the cabinet, as shown in [Figure 8-3](#).

Figure 8-3 E1 cables routed through the cabinet

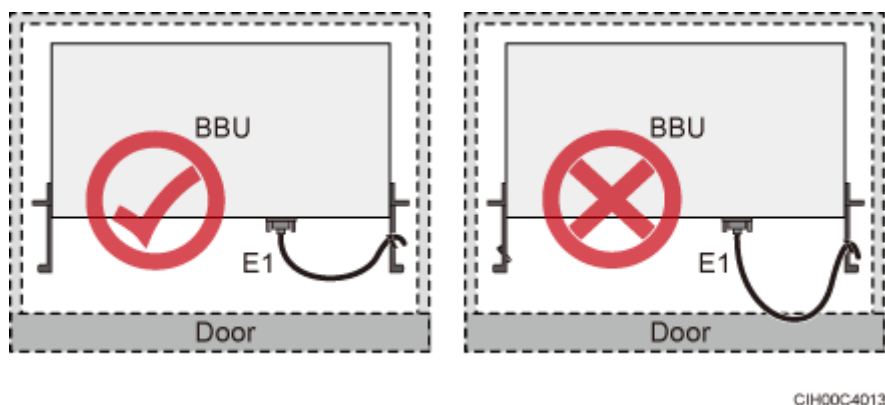

Cabling Requirements for Fiber Optic Cables

- Fiber optic cables must be routed by at least three qualified and trained personnel before all preparations are made.
- Fiber optic cables are used within the temperature range of -40°C to 60°C . If the current temperature is out of the range, make protection measures or route the cables again.
- Cables are routed in an untangled and orderly fashion.

- Do not bind fiber optic cables at turns.
- Do not stretch, step on, or place heavy objects on fiber optic cables. Keep the cables away from sharp objects.
- When fiber optic cables are routed, the excess of the cables must be coiled around special devices, such as a fiber coiler.
- When coiling fiber optic cables, apply even strength. Do not bend the cables with force.
- Vacant optical connectors must be covered with dustproof caps.
- Fiber optic cables cannot be squeezed by the cabinet door when routed through the cabinet, as shown in [Figure 8-4](#), [Figure 8-5](#) and [Figure 8-6](#).

Figure 8-4 CPRI fiber optic cables routed through the cabinet (1)

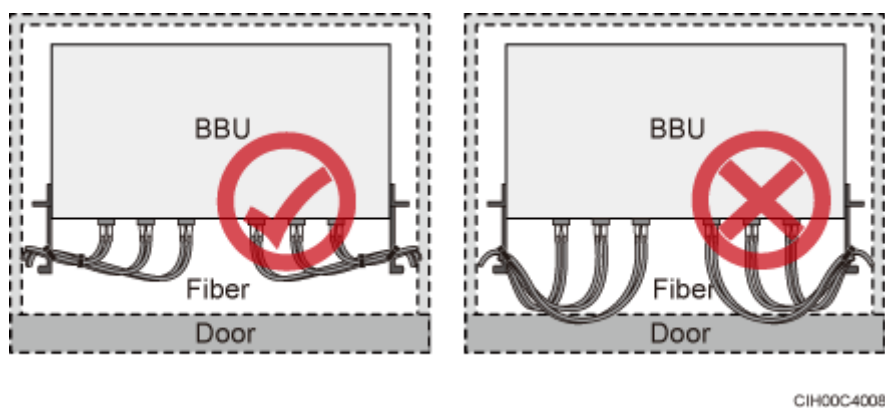

Figure 8-5 CPRI fiber optic cables routed through the cabinet (2)

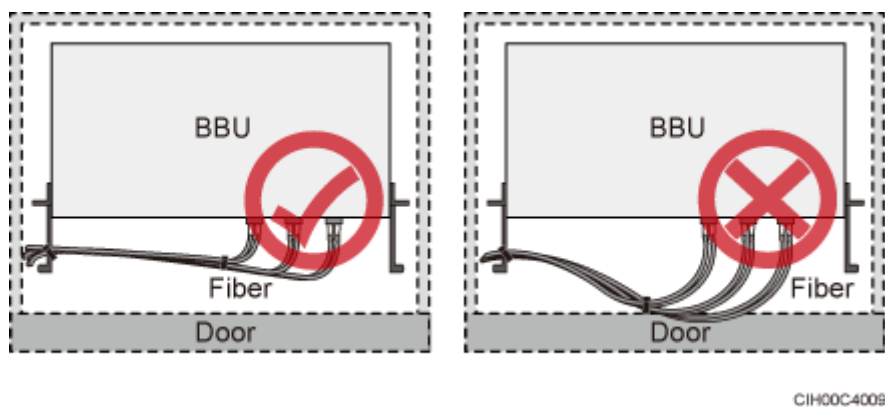
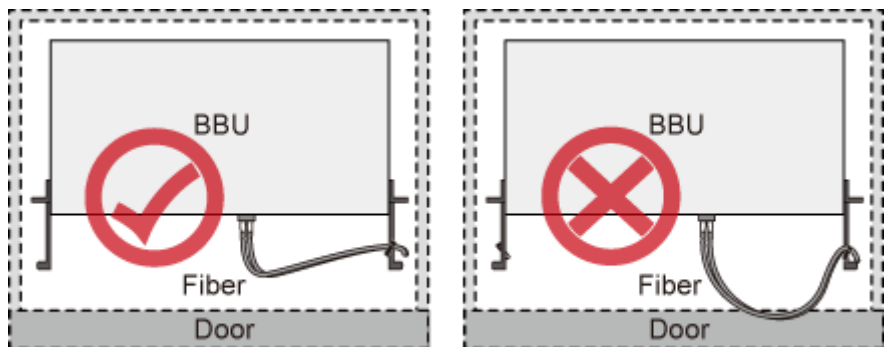

Figure 8-6 FE/GE cables routed through the cabinet

CIH00C4011

- If fiber optic cables need to be routed on the tower platform, lay out the cables on the guardrail with the shortest distance and route the cables along the guardrail.
- If fiber optic cables need to be routed close to a device on the tower, secure the cables to the guardrail or pole with cable clips. The device cannot be far away from the position for securing the cables.
- If the fiber optic cables close to a device are too long, coil the excess of the cables and secure them on the tower.

8.2 Cable Connections

This section describes the cable connections for a single RRU and multiple RRUs.

NOTE

A lower-level RRU obtains power directly from the external power system, but not from an upper-level RRU using a power cable.

For the cable connection between an RRU and an RGPS antenna (optional), refer to the document delivered with the RGPS antenna. For the cable connection between an RRU and an AUF (optional), refer to the document delivered with the AUF.

[Figure 8-7](#) shows the cable connections adopted for a single RRU when the alarm monitoring function is provided.

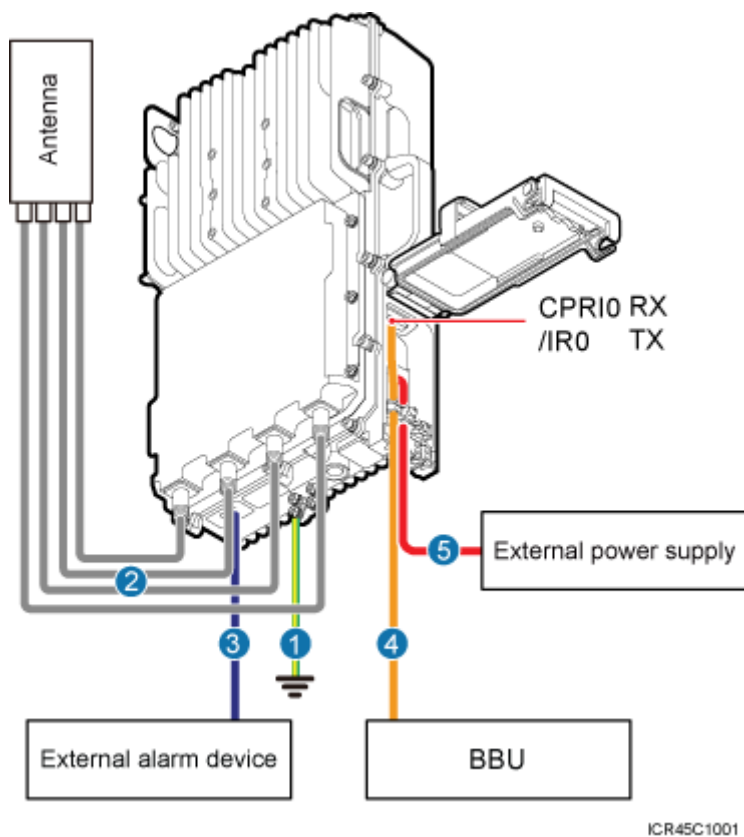
Figure 8-7 Cable connections for a single RRU (1)

- | | | |
|------------------------------|---------------------|-----------------------|
| (1) PGND cable | (2) RRU RF jumper | (3) RRU alarm cable |
| (4) CPRI optical fiber cable | (5) RRU power cable | (6) RGPS signal cable |

Figure 8-8 shows the cable connections adopted for a single RRU when the remote electrical tilt (RET) function is provided.

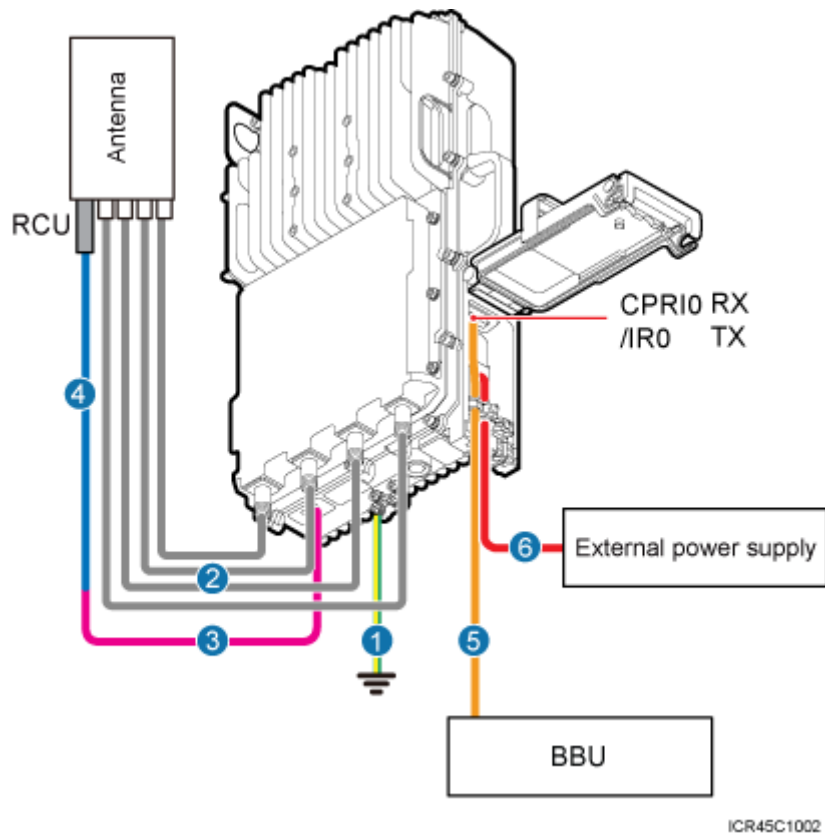
Figure 8-8 Cable connections for a single RRU (2)

- | | | |
|------------------------------|------------------------------|-------------------------------|
| (1) PGND cable | (2) RRU RF jumper | (3) RRU AISG multi-wire cable |
| (4) RRU AISG extension cable | (5) CPRI optical fiber cable | (6) RRU power cable |
| (7) RGPS signal cable | | |

Figure 8-9 shows the cable connections adopted for multiple RRUs when the alarm monitoring function is provided.

Figure 8-9 Cable connections for multiple RRUs (1)

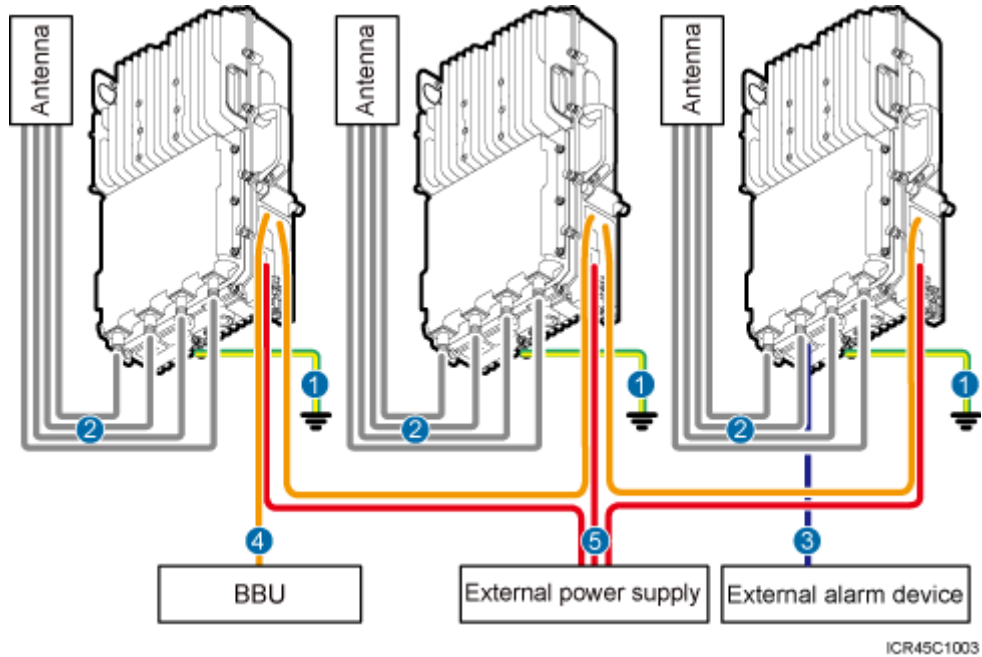

(1) PGND cable

(2) RRU RF jumper

(3) RRU alarm cable

(4) CPRI optical fiber cable or SFP high-speed cable for cascading RRUs

(5) RRU power cable

(6) RGPS signal cable

NOTE

If you must cascade two or more RRUs in the same cell, for example, to expand the capacity, install the alarm cable to the RRU at the last level.

Figure 8-10 shows the cable connections adopted for multiple RRUs when the remote electrical tilt (RET) function is provided.

Figure 8-10 Cable connections for multiple RRUs (2)

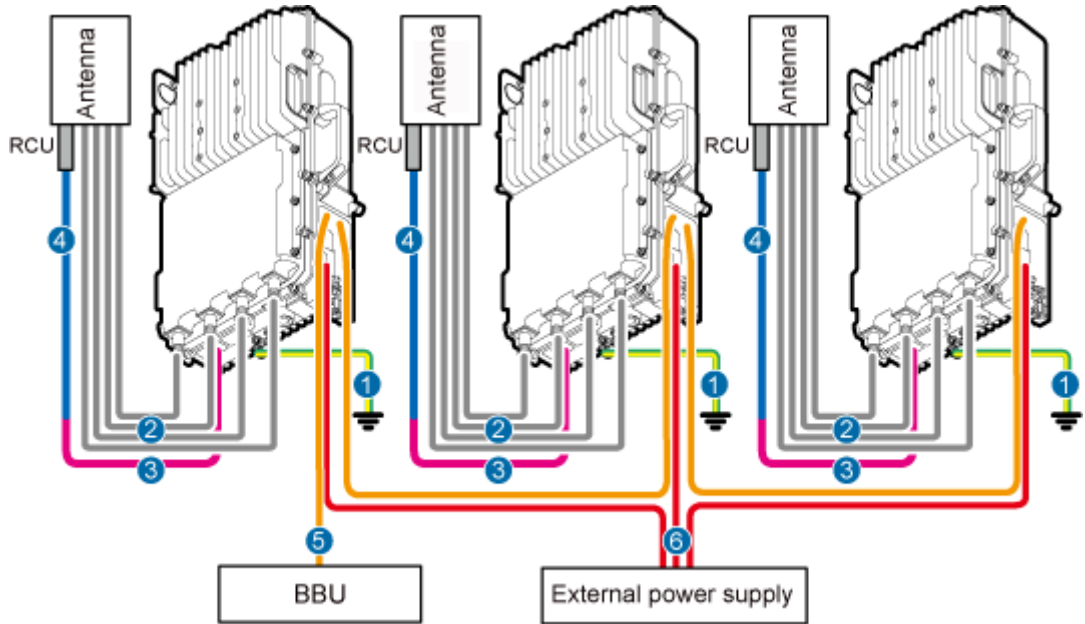

ICR45C1004

- (1) PGND cable
- (2) RRU RF jumper
- (3) RRU AISG multi-wire cable
- (4) RRU AISG extension cable
- (5) CPRI optical fiber cable or SFP high-speed cable for cascading RRUs
- (6) RRU power cable
- (7) RGPS signal cable

8.3 Installation Process

This section describes the process of installing RRU cables.

Figure 8-11 shows the process of installing RRU cables.

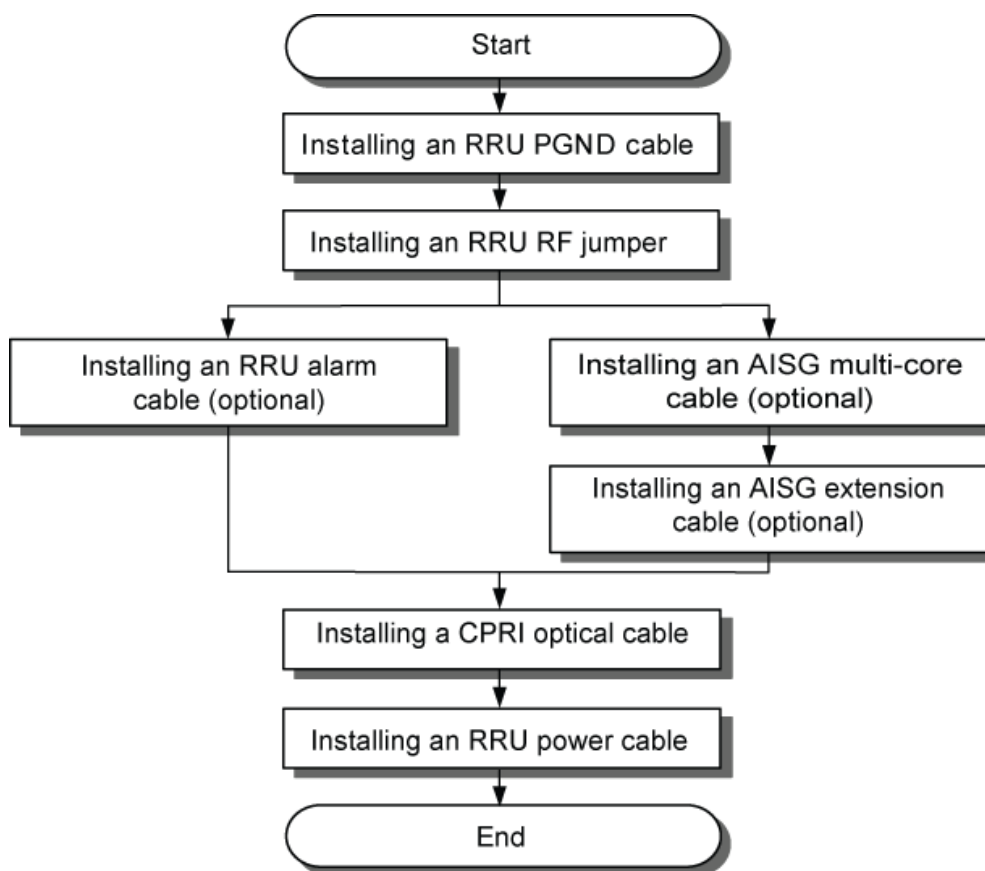
Figure 8-11 Process of installing RRU cables

IPR21C0002

8.4 RRU Cable List

This section describes RRU cable connections.

[Table 8-1](#) lists RRU cables.

Table 8-1 RRU cables

Cable	One End		The Other End	
	Connector	Connected to...	Connector	Connected to...
RRU PGND Cable	OT terminal (M6)	Ground terminal on the RRU	OT terminal (M8)	Ground terminal on the ground bar
RRU Power Cable	Tool-less female connector (pressfit type)	NEG(-) and RTN(+) ports on the RRU	Tool-less female connector (pressfit type)	One of RRU0 to RRU5 ports on the EPS
			OT terminal	One of LOAD0

Cable	One End		The Other End	
	Connector	Connected to...	Connector	Connected to...
			(M4)	to LOAD5 ports on the DCDU One of LOAD4 to LOAD9 ports on the PDU
CPRI Fiber Optic Cable	DLC connector	CPRI0/IR0 port on the RRU	DLC connector	CPRI port on the LBBP in the BBU
		CPRI1/IR1 port on the RRU		CPRI0/IR0 port on the RRU
RRU RF Jumper	Type N connector	ANT0 to ANT3 ports on the RRU	Type N connector	Antenna system
RGPS Jumper (optional)	Waterproofed DB15 connector	Remote Global Positioning System (RGPS) port at the RRU bottom	Round 12-pin connector	RGPS antenna
SFP High-Speed Cable for Cascaded RRUs (optional)	SFP20 male connector	CPRI1 port on the RRU	SFP20 male connector	CPRI0 port on the RRU
RRU Alarm Cable (optional)	Waterproofed DB9 male connector	RET/EXT_AL M port on the RRU	Cord end terminal	External alarm device
RRU AISG Multi-Wire Cable (optional)	Waterproofed DB9 male connector	RET/EXT_AL M port on the RRU	Standard AISG female connector	Standard AISG male connector on the remote control unit (RCU) or on the AISG extension cable
RRU AISG Extension Cable (optional)	Standard AISG male connector	Standard AISG female connector on the AISG multi-wire cable	Standard AISG female connector	Standard AISG male connector on the RCU

8.5 Installing an RRU PGND Cable

This section describes the procedure for installing an RRU PGND cable.

Context

The minimum cross-sectional area of an RRU PGND cable is 16 mm² (0.025 in.²). The cable has an M6 OT terminal at one end and an M8 terminal at the other end.

Procedure

Step 1 Prepare an RRU PGND cable.

1. Cut the cable to the required length based on the actual cable route.
2. Add an OT terminal to each end of the cable by referring to Assembling the OT Terminal and the Power Cable.

Step 2 Install the RRU PGND cable.

Connect the M6 OT terminal at one end of the PGND cable to the ground terminal at the RRU bottom and the M8 OT terminal at the other end to the external ground bar, as shown in [Figure 8-12](#).

Figure 8-12 Installing an RRU PGND cable

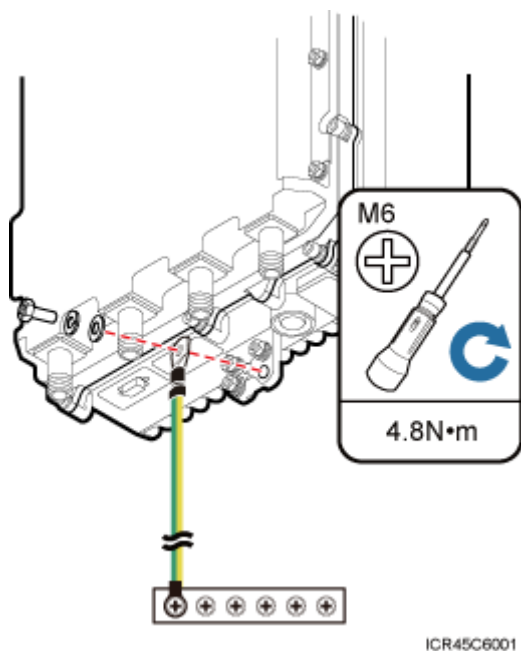

NOTE

Crimp OT terminals in correct directions, as shown in [Figure 8-13](#).

Figure 8-13 Correct direction of an OT terminal

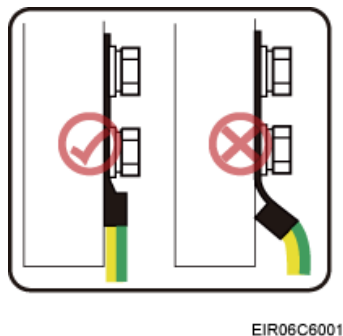

Step 3 Label the installed cable by referring to Attaching a Cable-Tying Label.
----End

8.6 Installing an RRU RF Jumper

This section describes the procedure for installing an RRU RF jumper.

Context

The RF ports on the RRU must be connected using RF jumpers to the mapping ANT0 to ANT3 ports on the antenna. [Figure 8-14](#) shows the mapping relationship between the RF ports and the antenna ports.

Figure 8-14 The mapping relationship between the RF ports and the antenna ports

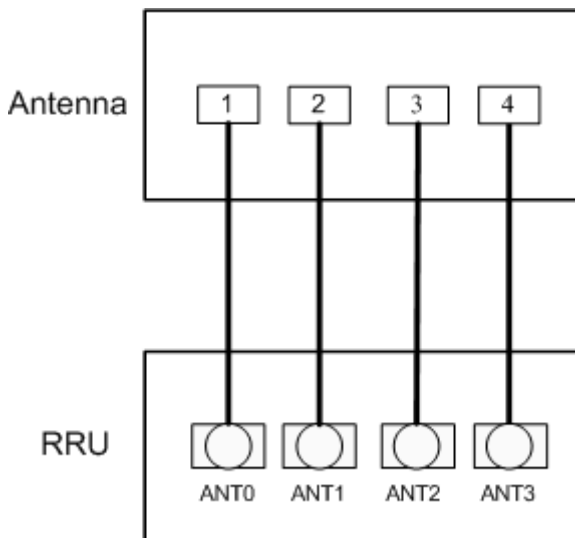

NOTE

The port labels in this figure are examples and for reference only.

Procedure

- Step 1** Connect the Type N connector at one end of the RRU RF jumper to the ANT port and use a torque wrench to tighten the connector with a torque of 1 N·m (12.39 lbf·in.), as shown in [Figure 8-15](#).

Figure 8-15 Installing an RRU RF jumper

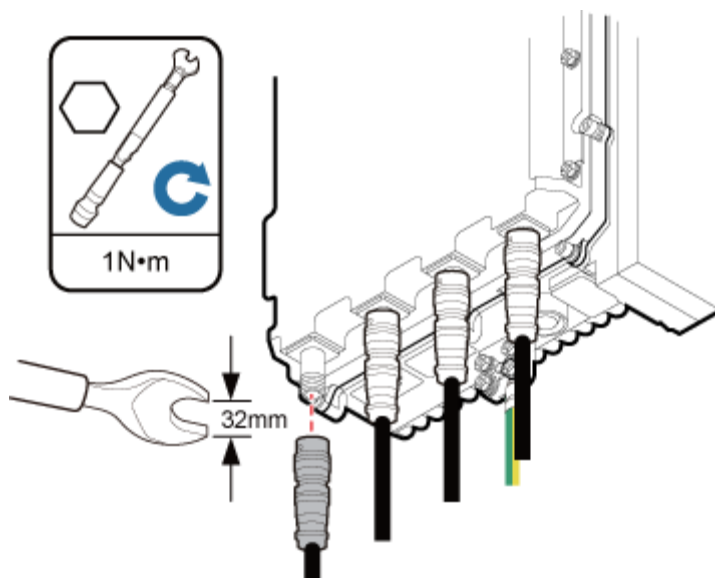

ICR45C5001



CAUTION

On AC-powered electric railways, such as high speed railways, when leaky cables are connected to RRUs installed in tunnels, high-voltage-resistant DC blocks must be installed between RRU RF jumpers and the leaky cables to protect the RRUs against damage.

- Step 2** Connect the other end of the RF jumper to the external antenna system.
- Step 3** Waterproof the connectors of the RF jumper by referring to [Figure 8-16](#).

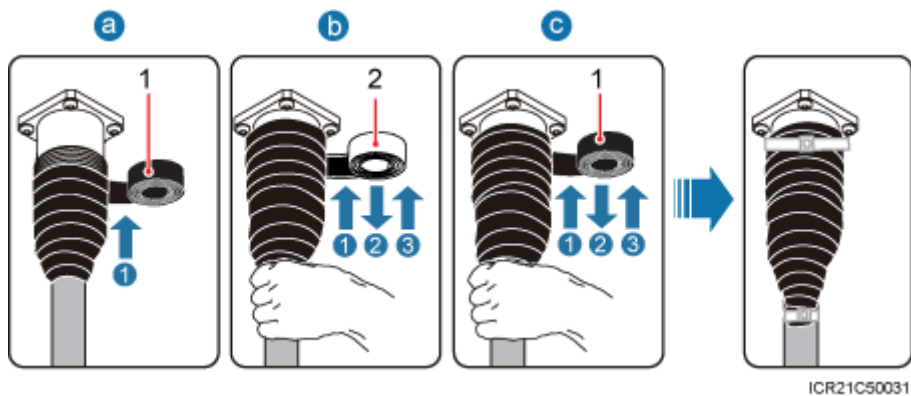
Figure 8-16 Waterproofing a connector of the RF jumper

(1) PVC insulation tape

(2) Waterproof tape

NOTE

- Before wrapping the waterproof tape, stretch the tape evenly until the length of the tape is twice its original length.
- Before wrapping the PVC insulation tape, do not stretch the PVC insulation tape.
- Ensure that each layer of tape overlaps more than 50% of the preceding layer. Stretch and press the tape tightly to avoid wrinkles or spaces. Ensure that the tape is tightly wrapped and stuck and will not fall off.
- Ensure that the adhesive surface of the tape overlaps the lower layer.
- Cable ties, cutting at the position of 3mm ~5mm far from head.

1. Wrap each connector with one layer of insulation tape from bottom up.
2. Wrap each connector with three layers of waterproof tape, first from bottom up, then from top down, and finally from bottom up. Do not cut the tape until all the three layers of the tape are already wrapped. Wrap each layer of tape around the connector tightly.
3. Wrap each connector with three layers of PVC insulation tape, first from bottom up, then from top down, and finally from bottom up. Do not cut the tape until all the three layers of the tape are already wrapped. Wrap each layer of tape around the connector tightly.

Step 4 Retain the dustproof caps on vacant antenna connectors and waterproof the dustproof caps, as shown in [Figure 8-17](#).

**CAUTION**

Do not remove dustproof caps from vacant antenna connectors.

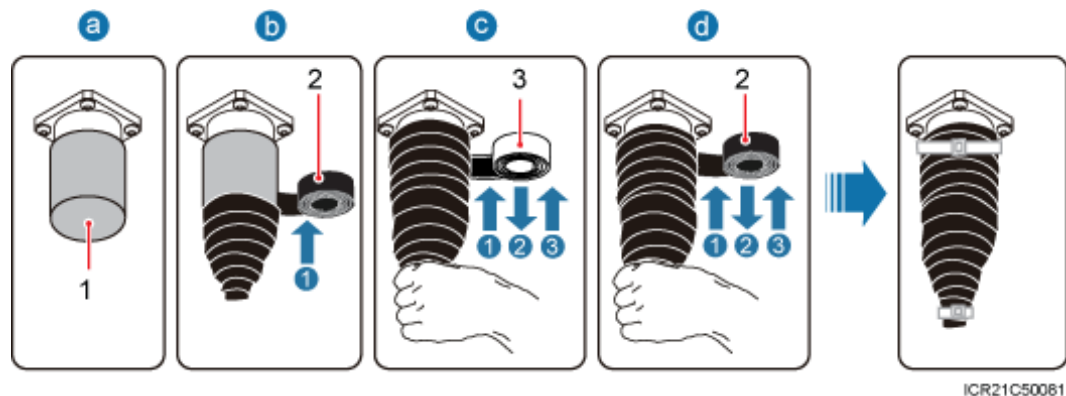
Figure 8-17 Waterproofing a dustproof cap

(1) Dustproof cap

(2) PVC insulation tape

(3) Waterproof tape

NOTE

- Before wrapping the waterproof tape, stretch the tape evenly until the length of the tape is twice its original length.
- Before wrapping the PVC insulation tape, do not stretch the PVC insulation tape.
- Ensure that each layer of tape overlaps more than 50% of the preceding layer. Stretch and press the tape tightly to avoid wrinkles or spaces. Ensure that the tape is tightly wrapped and stuck and will not fall off.
- Ensure that the adhesive surface of the tape overlaps the lower layer.
- Cable ties, cutting at the position of 3mm~5mm far from head.

1. Verify that dustproof caps are not removed.
2. Wrap each dustproof cap with one layer of PVC insulation tape from bottom up.
3. Wrap each dustproof cap with three layers of waterproof tape, first from bottom up, then from top down, and finally from bottom up. Do not cut the tape until all the three layers of the tape are already wrapped. Wrap each layer of tape around the cap tightly.
4. Wrap each dustproof cap with three layers of PVC insulation tape, first from bottom up, then from top down, and finally from bottom up. Do not cut the tape until all the three layers of the tape are already wrapped. Wrap each layer of tape around the connector tightly.

Step 5 Route the cable by referring to Cabling Requirements. Then, use cable ties to bind the cable.

Step 6 Label the installed cable by referring to Attaching a Sign Plate Label.

Step 7 Attach colored insulation tapes to the jumper by referring to Attaching the Color Ring.

----End

8.7 Installing an RRU Alarm Cable

This section describes the procedure for installing an RRU alarm cable.

Procedure

- Step 1** Connect the DB9 connector at one end of the RRU alarm cable to the RET/EXT_ALM port on the RRU, and connect the eight cord end terminals at the other end to the external alarm device, as shown in [Figure 8-18](#).

Figure 8-18 Installing an RRU alarm cable

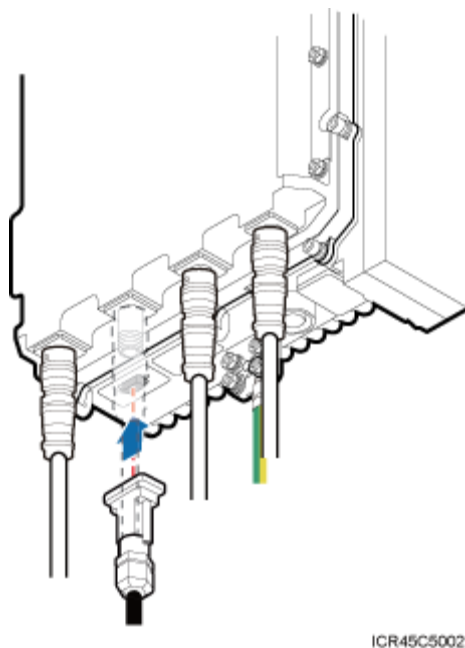

- Step 2** Route the cable by referring to Cabling Requirements. Then, use cable ties to bind the cable.

- Step 3** Label the installed cable by referring to Attaching an L-Shaped Label.

----End

8.8 Installing an RRU AISG Multi-Wire Cable and an RRU AISG Extension Cable

This section describes the procedures for installing an RRU AISG multi-wire cable and an RRU AISG extension cable.

Context

When the distance between an RRU and a Remote Control Unit (RCU) is longer than 5 m (16.4 ft.), an AISG multi-wire cable is not long enough to connect the RRU and the RCU. In this case, an AISG extension cable is used to extend the AISG multi-wire cable.

Procedure

- Install an AISG multi-wire cable that is not configured with an AISG extension cable.

1. Connect the waterproofed DB9 connector at one end of the AISG multi-wire cable to the RET/EXT_ALM port on the bottom of the RRU, as shown in [Figure 8-19](#).

Figure 8-19 Installing an RRU AISG multi-wire cable

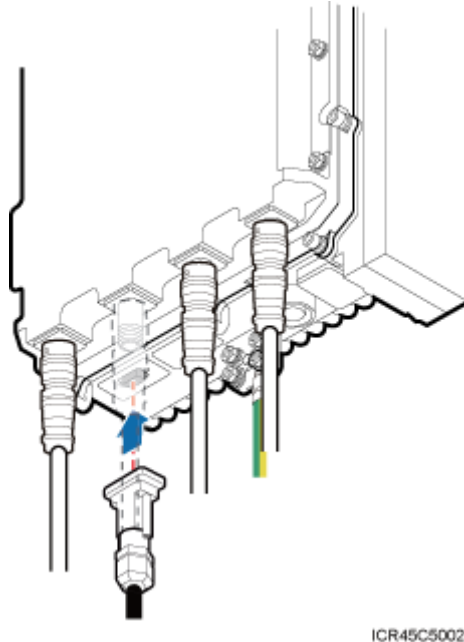

2. Connect the other end of the cable to the standard AISG male connector on the RCU.
 3. Route the cable by referring to Cabling Requirements. Then, use cable ties to bind the cable.
 4. Label the installed cable by referring to Attaching an L-Shaped Label.
- Install an AISG multi-wire cable that is configured with an AISG extension cable.
1. Connect the waterproofed DB9 connector at one end of the AISG multi-wire cable to the RET/EXT_ALM port on the bottom of the RRU, and the other end of the cable to the standard AISG male connector of the AISG extension cable, as shown in [Figure 8-20](#).

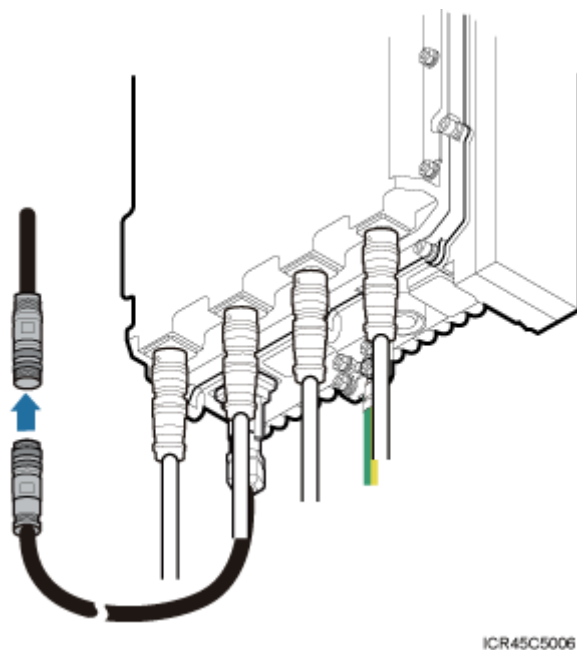
Figure 8-20 Installing an RRU AISG multi-wire cable

2. Connect the other end of the AISG extension cable to the standard AISG male connector on the RCU, as shown in [Figure 8-21](#).

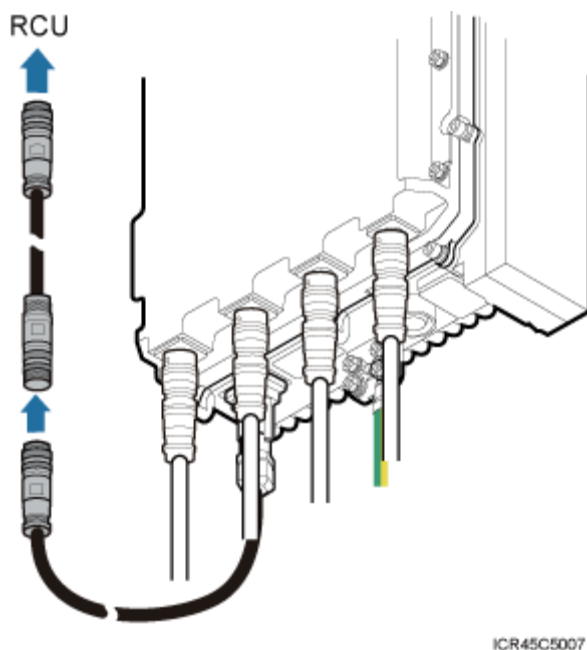
Figure 8-21 Installing an RRU AISG multi-wire cable

3. Route the cable by referring to Cabling Requirements. Then, use cable ties to bind the cable.
4. Label the installed cable by referring to Attaching an L-Shaped Label.

----End

8.9 Opening the Cover Plate of an RRU Cabling Cavity

This section describes the procedure for opening the cover plate of an RRU cabling cavity.

Procedure

Step 1 Wear ESD gloves.



Take proper ESD protection measures, for example, wear ESD gloves, to prevent electrostatic damage to the boards, modules, or electronic components.

Step 2 Use an M4 Phillips screwdriver to loosen the protection screw on the cover plate of the RRU cabling cavity, and pull the handle outwards to open the cover plate, as shown in [Figure 8-22](#).

Figure 8-22 Opening the cover plate of the RRU cabling cavity

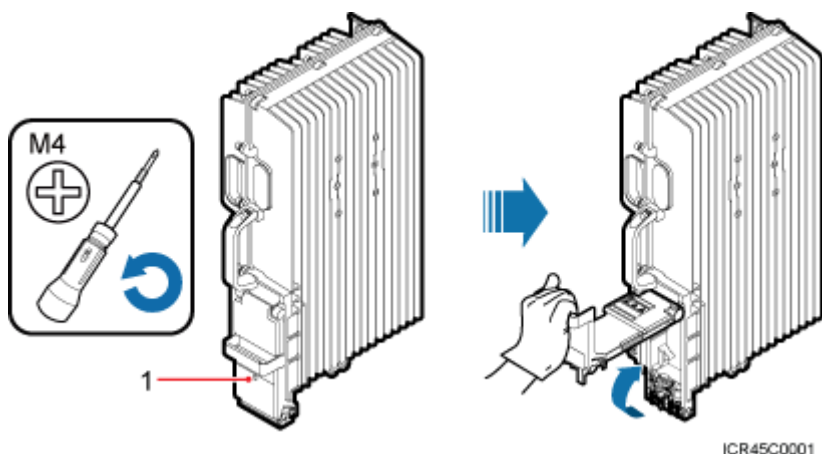

(1) Protection screw

[Figure 8-23](#) shows the RRU cabling cavity.

Figure 8-23 RRU cabling cavity

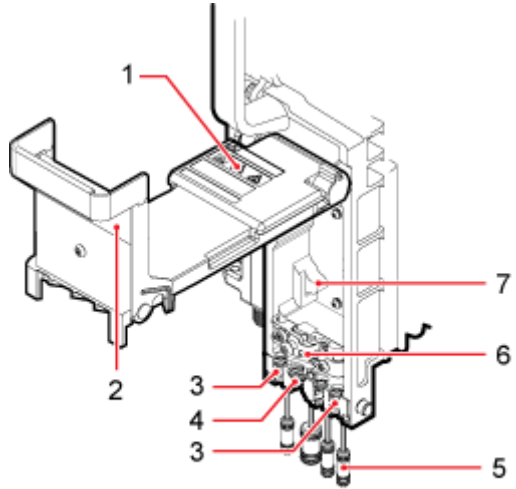

ICR45C0002

- | | | |
|--------------------------------------|----------------------------|--|
| (1) Cover plate | (2) Cable diagram on label | (3) Cable trough for the optical fiber cable |
| (4) Cable trough for the power cable | (5) Waterproof block | (6) Clip |
| (7) Cabling cavity | - | - |

Step 3 Loosen the screws on the clips, and open the clips, as shown [Figure 8-24](#).



NOTE

Open the clips only for the cables to be installed.

Figure 8-24 Opening clips

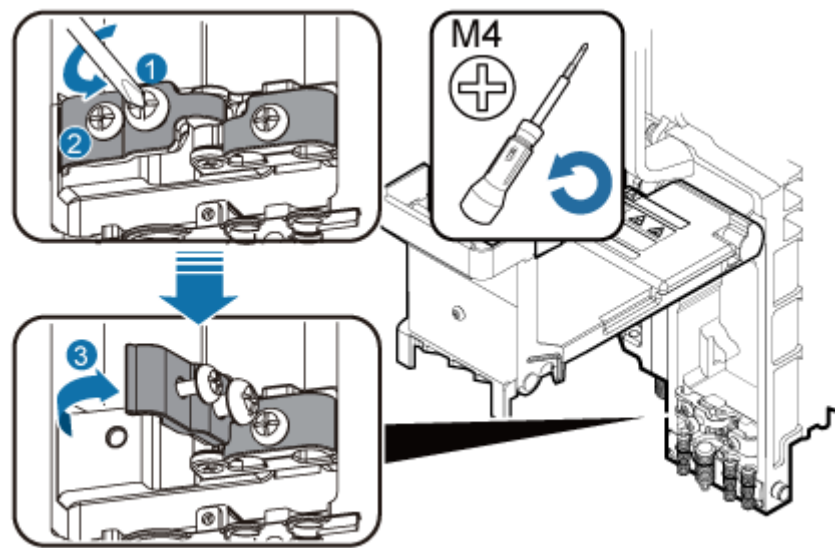

ICR45C0003

----End

8.10 Installing an RRU Power Cable

This section describes the procedure for installing an RRU power cable.

Prerequisites

A tool-less female connector (pressfit type) is added to the RRU power cable on the RRU side. For details, see [11.1 Adding an Easy Power Receptacle \(Pressfit Type\) Connector to an RRU Power Cable](#).

Context



CAUTION

When installing the RRU power cable, connect the RRU power cable first to the RRU and then to the power device. Operations in the reverse sequence may cause damage to the components and injury of human bodies.

Procedure

- Install an RRU power cable that feeds power to an RRU from a DCDCU when the DCDCU is configured.
1. Connect the tool-less female connector (pressfit type) at one end of the RRU power cable to the power supply socket on the RRU, as shown in [Figure 8-25](#).

Figure 8-25 Installing an RRU power cable

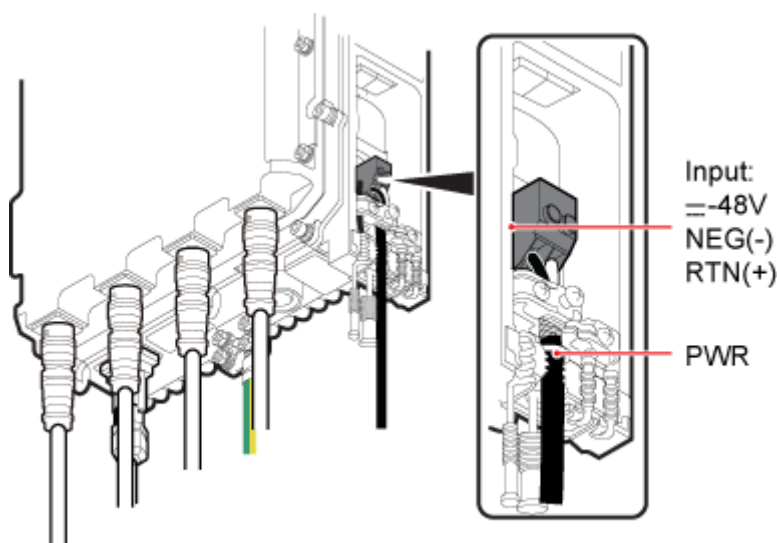

ICR45C2001



Ensure that the exposed shield layer of the power cable is properly tightened using the clip.

2. Connect the other end of the RRU power cable to the output terminal on the DCDU.
 3. Route the cable by referring to Cabling Requirements. Then, use cable ties to bind the cable.
 4. Label the installed cable by referring to Attaching a Cable-Tying Label.
- Install an RRU power cable that feeds power to an RRU from the embedded power system (EPS) when the EPS is configured.
1. Connect the tool-less female connector (pressfit type) at one end of the RRU power cable to the power supply socket on the RRU, as shown in [Figure 8-25](#).
 2. Connect the tool-less female connector (pressfit type) at one end of the RRU power cable to the RRU0 port on the EPS subrack.

**NOTE**

- The blue core wire in the tool-less female connector (pressfit type) is connected to the left port on the EPS subrack, and the black/brown core wire is connected to the right port on the EPS subrack.
 - The EPS can supply power to a maximum of six RRUs. The RRU power cable can be connected to any of RRU0 to RRU5 ports on the EPS subrack.
3. Route the cable by referring to Cabling Requirements. Then, use cable ties to bind the cable.
 4. Label the installed cable by referring to Attaching a Cable-Tying Label.

----End

8.11 Installing an Optical Fiber Cable

This section describes the procedure for installing an optical fiber cable.

Prerequisites

Before the installation, distinguish single-mode optical modules from multi-mode optical modules by either of the following means:

- SM and MM labels on an optical module: SM indicates a single-mode optical module, and MM indicates a multi-mode optical module.
- Color of the puller on an optical module: Blue indicates a single-mode optical module, and black or gray indicates a multi-mode optical module.



The optical modules to be installed must match the rates of their corresponding CPRI ports.

Context

A CPRI optical fiber cable transmits CPRI signals between a BBU and an RRU.

Procedure

- Step 1** Lower the pullers of two optical modules, insert one optical module into the **CPRI0** port on the RRU and the other optical module into the **CPRI** port on the BBU, and raise the pullers, as shown in [Figure 8-26](#).

Figure 8-26 Installing an optical module

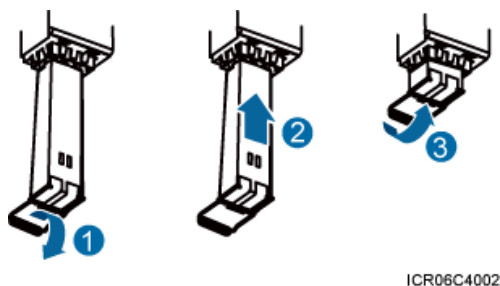

ICR06C4002



CAUTION

The performance of an optical module that is exposed to the air for more than 20 minutes may be abnormal. Therefore, you must insert a fiber optic cable into an unpacked optical module within 20 minutes.

- Step 2** Connect the end labeled 1A and 1B of the optical fiber cable to the optical module on the RRU side, as shown in [Figure 8-27](#).

Figure 8-27 Installing a CPRI optical fiber cable

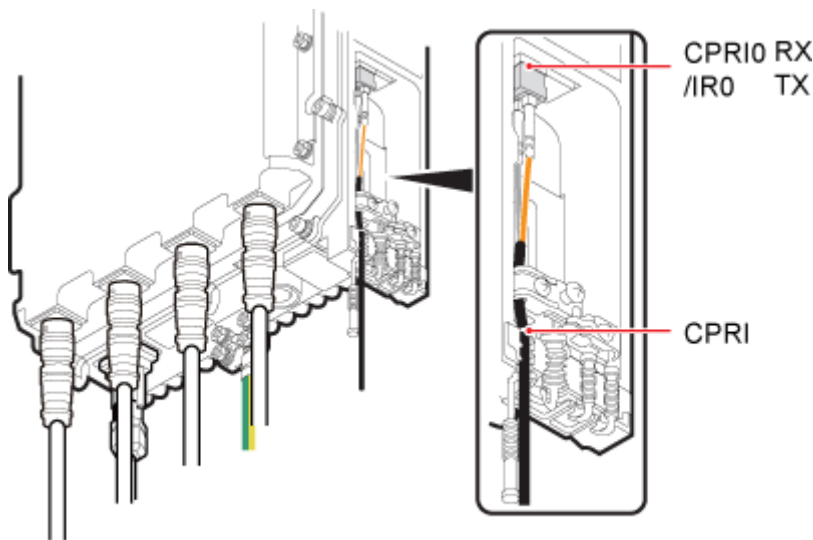

ICR45C4001

**CAUTION**

To avoid any damage to optical fiber cables, secure the optical fiber cable in the cable clip near the power cable to leave some slack at the bend. Tighten the screws on the cable clip with a torque of 1.4 N·m (12.39 lbf·in.).

- Step 3** Connect the end labeled 2A and 2B of the optical fiber cable to the optical module on the BBU side.
- Step 4** Route the cable by referring to Cabling Requirements. Then, use cable ties to bind the cable.
- Step 5** Label the optical fiber cable by referring to Attaching an L-Shaped Label.
- End

8.12 Closing the Cover Plate of an RRU Cabling Cavity

This section describes the procedure for closing the cover plate of an RRU cabling cavity.

Procedure

- Step 1** Close clips and use a torque screwdriver to tighten the screws on each clip with a torque of 1.4 N·m (12.39 lbf·in.), as shown in [Figure 8-28](#).

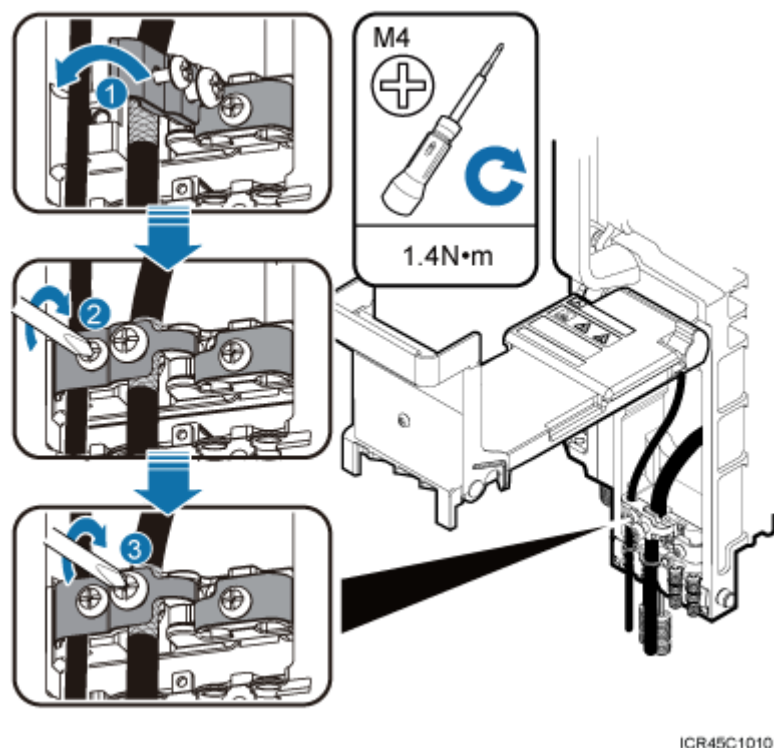
Figure 8-28 Closing clips**CAUTION**

Ensure that the exposed shield layer of the power cable is properly tightened using the clip.

- Step 2** Insert waterproof blocks into vacant cable troughs in the cabling cavity, as shown in [Figure 8-29](#).

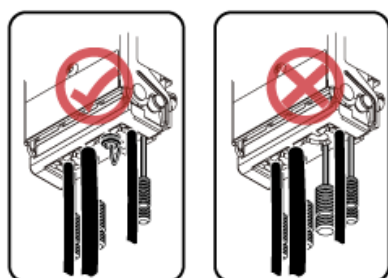
Figure 8-29 Correct placement of waterproof blocks

- Step 3** Close the cover plate of the RRU cabling cavity, and use a torque screwdriver to tighten the screws on the cover plate with a torque of 1.4 N·m (12.39 lbf·in.), as shown in [Figure 8-30](#).

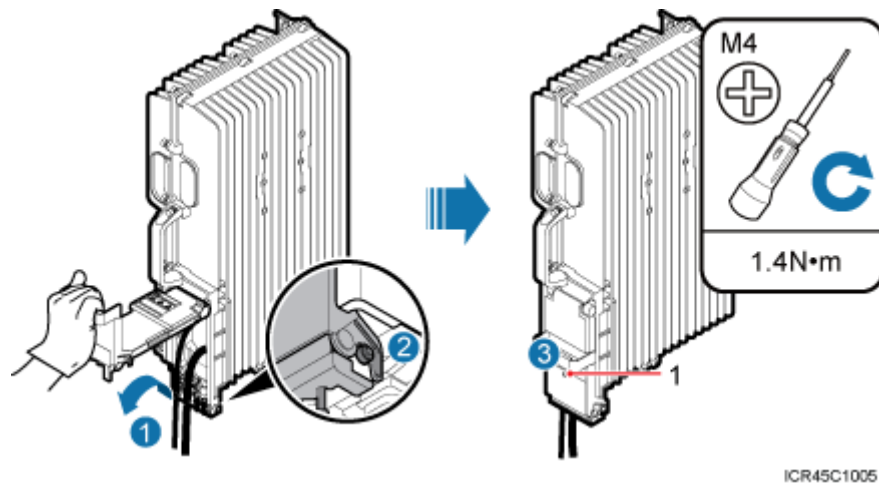
Figure 8-30 Closing the cover plate of the RRU cabling cavity

(1) Protection screw



CAUTION

Before tightening the screws on the cover plate, ensure that cables and waterproof blocks are properly inserted into troughs.

Step 4 Take off the ESD gloves, and pack up all the tools.

----End

9

Checking the RRU Hardware Installation

This section describes how to check RRU hardware installation after the installation is complete.

[Table 9-1](#) provides the checklist for the RRU hardware installation.

Table 9-1 Checklist for the RRU hardware installation

SN	Item
1	The position for each device conforms to the engineering drawing and meets the space requirement. Sufficient space is reserved for equipment maintenance.
2	The RRU is securely installed.
3	The cover plate is securely installed on the RRU cabling cavity.
4	Waterproof blocks are securely installed in vacant cable troughs of the RRU cabling cavity, and the cover plate for the cabling cavity is securely installed. In addition, vacant RF ports are covered with dustproof caps and the caps are waterproofed.
5	There are no connectors or joints on each power cable or PGND cable.
6	The terminals at two ends of each power cable or PGND cable are securely soldered or crimped.
7	None of power cables and PGND cables can be short-circuited or reversely connected. In addition, these cables are not damaged or broken.
8	Power cables and PGND cables are separately bound from other cables.
9	The protection grounding of the RRU and the surge protection grounding of the building share one group of ground conductors.
10	The connectors of each signal cable are intact and securely linked, and these cables are not damaged or broken.
11	Labels are correct, legible, and complete at both ends of each cable, feeder, and jumper.

10 Powering On an RRU

This section describes how to check the power-on status of an RRU after all the devices are installed.

Figure 10-1 shows the RRU power-on check process.

Figure 10-1 Powering on an RRU

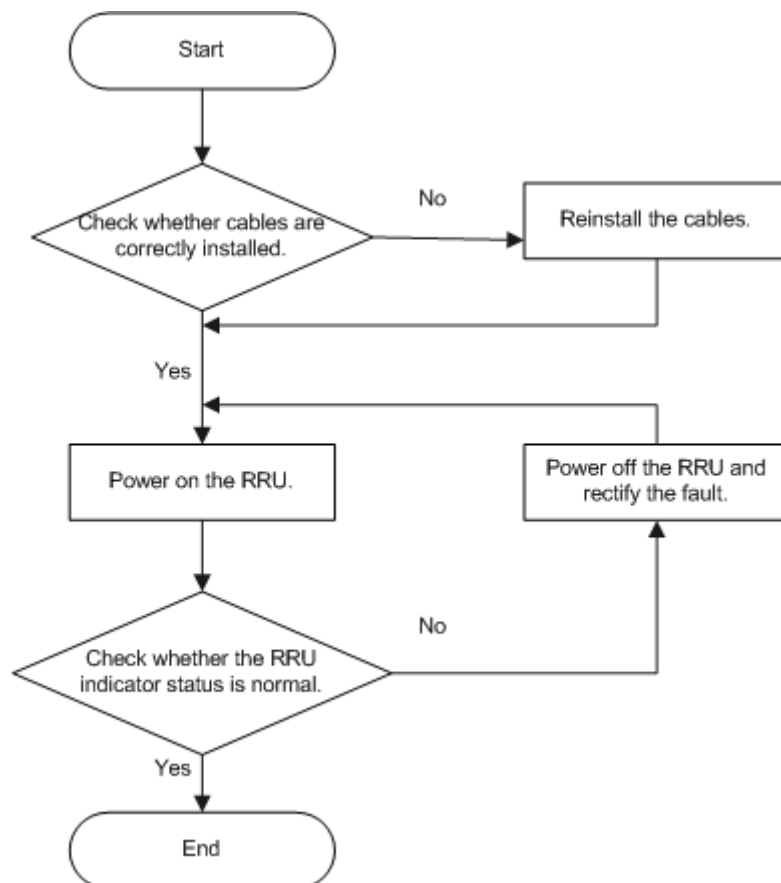



NOTE

- The RRU is provided with -48 V DC power and the external voltage ranges from -32 V DC to -60 V DC.
- When the RRU is working properly, the RUN indicator blinks one second on and one second off, and the ALM indicator is steady off.

11 Appendix

About This Chapter

This section describes the procedure for adding an easy power receptacle (pressfit type) connector.

11.1 Adding an Easy Power Receptacle (Pressfit Type) Connector to an RRU Power Cable

This section describes the procedure for adding an easy power receptacle (pressfit type) connector to an RRU power cable.

11.1 Adding an Easy Power Receptacle (Pressfit Type) Connector to an RRU Power Cable

This section describes the procedure for adding an easy power receptacle (pressfit type) connector to an RRU power cable.

Procedure

- Step 1** Open the cabling cavity and take out the easy power receptacle (pressfit type) connector. Then, mark the lengths of the power cable for different operations based on the label on the cover of the cabling cavity, as shown in [Figure 11-1](#).

Figure 11-1 Marking the lengths of the RRU power cable for different operations

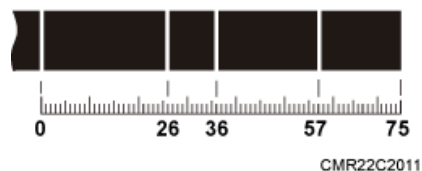

- Step 2** Use a cable cutter and wire stripper to strip off the specified length of the sheath from the power cable, as shown in [Figure 11-2](#).

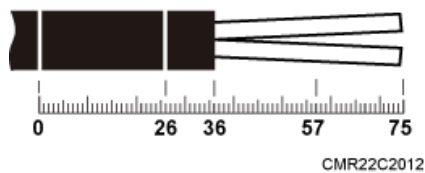
Figure 11-2 Stripping off the specified length of sheath from the power cable

Step 3 Strip off the sheath from each core wire, as shown in [Figure 11-3](#).

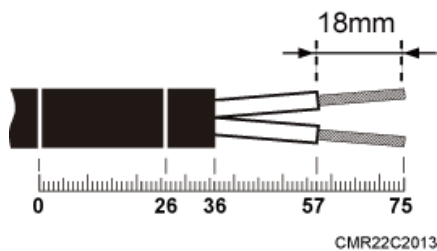
Figure 11-3 Stripping off the sheath from each core wire**NOTE**

Ensure that the length of the sheath stripped off from each core wire must match the length of the notch in the easy power receptacle (pressfit type) connector, as shown in [Figure 11-4](#).

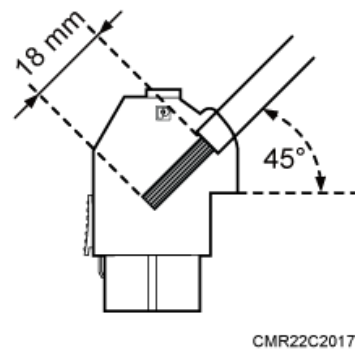
Figure 11-4 Stripping off the sheath from each core wire

Step 4 Strip off the sheath from the power cable to expose its shield layer, as shown in [Figure 11-5](#).

Figure 11-5 Stripping off the sheath from the power cable to expose its shield layer

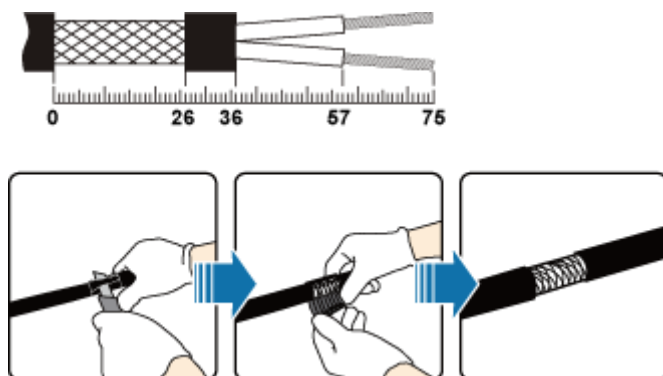

Step 5 Use a Phillips screwdriver to loosen the screws, as shown in [Figure 11-6](#).

Figure 11-6 Loosening screws

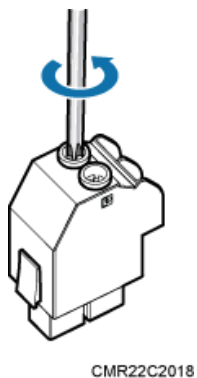

Step 6 Connect the blue core wire labeled NEG(-) to the - port and connect the black core wire labeled RTN(+) to the + port on the easy power receptacle (pressfit type) connector. Then, tighten the screws, as shown in [Figure 11-7](#).

Figure 11-7 Adding an easy power receptacle (pressfit type) connector to a power cable

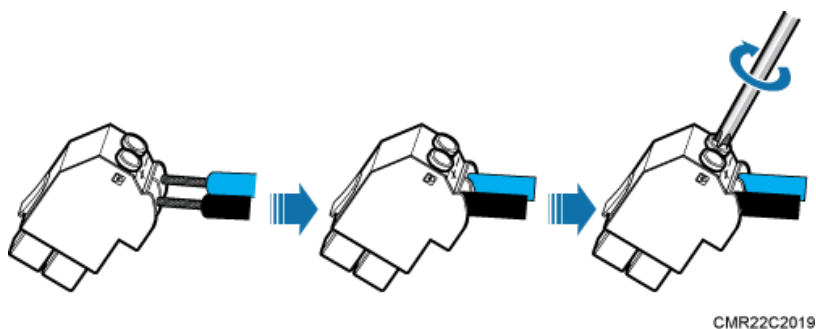

Ensure that only a 1.5 mm (0.06 in.) core wire is exposed out of the connector and that the exposed part cannot be folded, as shown in [Figure 11-8](#).

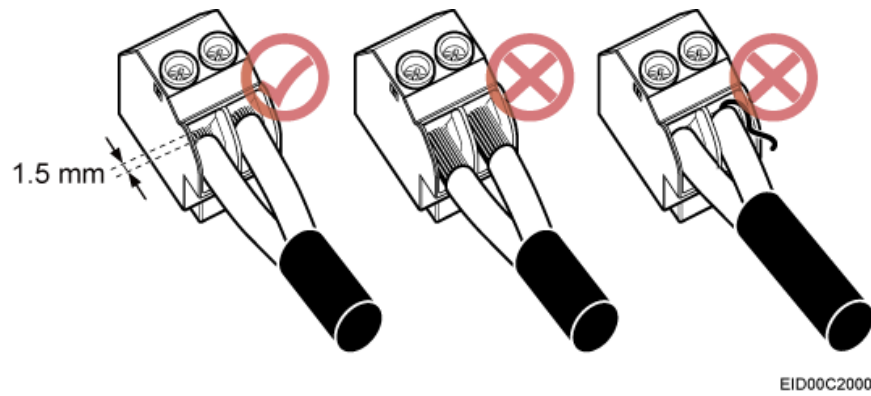
Figure 11-8 Easy power receptacle (pressfit type) connectors installed in different ways

 **CAUTION**

If the wire connections are incorrect, the equipment cannot be powered on. Correctly connect the wires 10 seconds later.

Step 7 Confirm that the core wires are securely connected to the connector, as shown in [Figure 11-9](#).

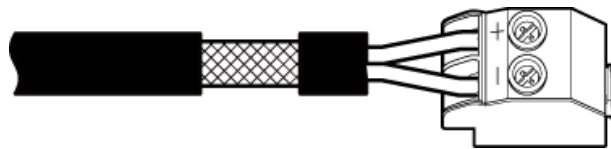
Figure 11-9 Correct installation of an easy power receptacle (pressfit type) connector

----End