



RRU3642

V400

Installation Guide

Issue 01

Date 2011-12-27

Copyright © Huawei Technologies Co., Ltd. 2011. All rights reserved.

No part of this document may be reproduced or transmitted in any form or by any means without prior written consent of Huawei Technologies Co., Ltd.

Trademarks and Permissions



HUAWEI and other Huawei trademarks are trademarks of Huawei Technologies Co., Ltd.

All other trademarks and trade names mentioned in this document are the property of their respective holders.

Notice

The purchased products, services and features are stipulated by the contract made between Huawei and the customer. All or part of the products, services and features described in this document may not be within the purchase scope or the usage scope. Unless otherwise specified in the contract, all statements, information, and recommendations in this document are provided "AS IS" without warranties, guarantees or representations of any kind, either express or implied.

The information in this document is subject to change without notice. Every effort has been made in the preparation of this document to ensure accuracy of the contents, but all statements, information, and recommendations in this document do not constitute the warranty of any kind, express or implied.

Huawei Technologies Co., Ltd.

Address: Huawei Industrial Base
Bantian, Longgang
Shenzhen 518129
People's Republic of China

Website: <http://www.huawei.com>

Email: support@huawei.com

About This Document

Overview

This document describes the procedure for installing a direct current (DC) RRU3642 (referred to as RRU in this document). RRU is short for remote radio unit.

Product Version

The following table lists the product version related to this document.

Product Name	Product Version
DBS3900	V400

Intended Audience

This document is intended for:

- Base station installation engineers

Organization

[1 Changes in the RRU3642 Installation Guide](#)

This chapter describes changes in the *RRU3642 Installation Guide*.

[2 Installation Preparations](#)

Before the installation, you must obtain all reference documents and required tools and instruments, and have been trained on installation skills.

[3 Information About the Installation](#)

Before installing an RRU, you must be familiar with its exterior, ports, installation options, physical supports, and installation clearance requirements.

[4 Unpacking the Equipment](#)

Unpack and check the delivered equipment to ensure that all the materials are included and intact.

5 Installation Process

The installation process involves installing an RRU and RRU cables, checking the RRU hardware installation, and powering on the RRU.

6 Installing the RRU

This chapter describes the procedure for installing the RRU. The RRU can be installed on a pole, U-steel, angle steel, or wall. The procedure for installing the RRU varies depending on installation options.

7 Installing RRU Cables

This section describes the procedures for installing remote radio unit (RRU) cables.

8 Checking the RRU Hardware Installation

After an RRU is installed, check the hardware installation.

9 Powering On an RRU

After all the devices are installed, check the power-on status of an RRU.





10 Appendix

This section describes the procedure for adding an easy power receptacle (pressfit type) connector.

Conventions

Symbol Conventions

The symbols that may be found in this document are defined as follows.

Symbol	Description
 DANGER	Indicates a hazard with a high level of risk, which if not avoided, will result in death or serious injury.
 WARNING	Indicates a hazard with a medium or low level of risk, which if not avoided, could result in minor or moderate injury.
 CAUTION	Indicates a potentially hazardous situation, which if not avoided, could result in equipment damage, data loss, performance degradation, or unexpected results.
 TIP	Indicates a tip that may help you solve a problem or save time.
 NOTE	Provides additional information to emphasize or supplement important points of the main text.

General Conventions

The general conventions that may be found in this document are defined as follows.

Convention	Description
Times New Roman	Normal paragraphs are in Times New Roman.
Boldface	Names of files, directories, folders, and users are in boldface . For example, log in as user root .
<i>Italic</i>	Book titles are in <i>italics</i> .
Courier New	Examples of information displayed on the screen are in Courier New.

Command Conventions

The command conventions that may be found in this document are defined as follows.

Convention	Description
Boldface	The keywords of a command line are in boldface .
<i>Italic</i>	Command arguments are in <i>italics</i> .
[]	Items (keywords or arguments) in brackets [] are optional.
{ x y ... }	Optional items are grouped in braces and separated by vertical bars. One item is selected.
[x y ...]	Optional items are grouped in brackets and separated by vertical bars. One item is selected or no item is selected.
{ x y ... }*	Optional items are grouped in braces and separated by vertical bars. A minimum of one item or a maximum of all items can be selected.
[x y ...]*	Optional items are grouped in brackets and separated by vertical bars. Several items or no item can be selected.

GUI Conventions

The GUI conventions that may be found in this document are defined as follows.

Convention	Description
Boldface	Buttons, menus, parameters, tabs, window, and dialog titles are in boldface . For example, click OK .
>	Multi-level menus are in boldface and separated by the ">" signs. For example, choose File > Create > Folder .

Keyboard Operations

The keyboard operations that may be found in this document are defined as follows.

Format	Description
Key	Press the key. For example, press Enter and press Tab .
Key 1+Key 2	Press the keys concurrently. For example, pressing Ctrl+Alt+A means the three keys should be pressed concurrently.
Key 1, Key 2	Press the keys in turn. For example, pressing Alt, A means the two keys should be pressed in turn.

Mouse Operations

The mouse operations that may be found in this document are defined as follows.

Action	Description
Click	Select and release the primary mouse button without moving the pointer.
Double-click	Press the primary mouse button twice continuously and quickly without moving the pointer.
Drag	Press and hold the primary mouse button and move the pointer to a certain position.

Contents

About This Document.....	ii
1 Changes in the RRU3642 Installation Guide.....	1
2 Installation Preparations.....	2
2.1 Reference Documents.....	3
2.2 Tools and Instruments.....	3
2.3 Skills and Requirements for Onsite Personnel.....	4
3 Information About the Installation.....	5
3.1 RRU Exterior.....	6
3.2 RRU Ports.....	6
3.3 RRU Indicators.....	9
3.4 Installation Options.....	10
3.5 Installation Clearance Requirements of an RRU.....	15
3.5.1 Installation Clearance for a Single RRU.....	15
3.5.2 Installation Clearance for Multiple RRUs.....	17
3.5.3 Installation Spacing Between RRUs.....	20
4 Unpacking the Equipment.....	24
5 Installation Process.....	26
6 Installing the RRU.....	27
6.1 Mounting Kits for an RRU.....	29
6.2 Installing the RRU on a Pole.....	29
6.2.1 Installing a Single RRU.....	32
6.2.2 Installing Two RRUs.....	34
6.2.3 Installing Multiple RRUs.....	37
6.3 Installing the RRU on U-steel.....	40
6.4 Installing the RRU on Angle Steel.....	44
6.5 Installing the RRU on a Wall.....	47
6.6 Hoisting an RRU onto a Tower.....	51
7 Installing RRU Cables.....	55
7.1 Cabling Requirements.....	57
7.2 Cable Connections.....	62

7.3 Installation Process.....	65
7.4 RRU Cable List.....	65
7.5 Installing the RRU PGND Cable.....	68
7.6 Installing an RRU RF Jumper.....	69
7.7 Installing an Inter-RRU RF Cable.....	72
7.8 Installing an RRU AISG Multi-Wire Cable and AISG Extension Cable.....	73
7.9 Opening the Cover Plate of an RRU Cabling Cavity.....	75
7.10 Installing an RRU power cable.....	77
7.11 Installing a CPRI Fiber Optic Cable.....	79
7.12 Installing an RRU Alarm Cable.....	81
7.13 Closing the Cover Plate of an RRU Cabling Cavity.....	82
8 Checking the RRU Hardware Installation.....	84
9 Powering On an RRU.....	85
10 Appendix.....	86
10.1 Adding an Easy Power Receptacle (Pressfit Type) Connector to the RRU Power Cable on the RRU Side	87

1 Changes in the RRU3642 Installation Guide

This chapter describes changes in the *RRU3642 Installation Guide*.

Draft A (2011-12-30)

This is the draft.

2 Installation Preparations

About This Chapter

Before the installation, you must obtain all reference documents and required tools and instruments, and have been trained on installation skills.

[2.1 Reference Documents](#)

Before the installation, you must familiarize yourself with the information in the following documents:

[2.2 Tools and Instruments](#)

All tools and instruments required for RRU installation must be ready before the installation.

[2.3 Skills and Requirements for Onsite Personnel](#)

Onsite personnel must be qualified and trained. Before performing any operation, onsite personnel must be familiar with correct operation methods and safety precautions.









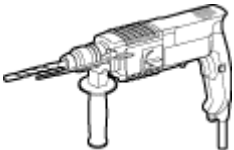
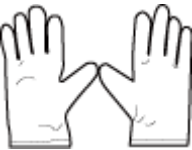

2.1 Reference Documents





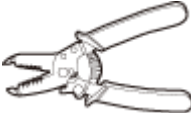





Before the installation, you must familiarize yourself with the information in the following documents:

- RRU3642 Hardware Description
- RRU Hardware Maintenance Guide
- DBS3900 Installation Guide
- OCB User Guide

2.2 Tools and Instruments

All tools and instruments required for RRU installation must be ready before the installation.

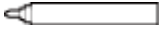
<p>Hammer drill (a ϕ 14 bit)</p> 	<p>ESD gloves</p> 	<p>Vacuum cleaner</p> 
<p>Heat gun</p> 	<p>Phillips screwdriver (M3 to M6)</p> 	<p>Flat-head screwdriver (M3 to M6)</p> 
<p>Rubber mallet</p> 	<p>COAX crimping tool</p> 	<p>Wire stripper</p> 
<p>Utility knife</p> 	<p>Cable cutter</p> 	<p>Adjustable wrench (capacity \geq 32 mm [1.26 in.])</p> 

<p>Level</p> 	<p>Torque screwdriver</p>   <p>5 mm</p>  <p>(M3 to M6)</p>  <p>(M3 to M6)</p>	<p>Torque wrench</p>  <p>Capacity: 17 mm [0.67 in.], 21 mm [0.82 in.], and 32 mm [1.26 in.]</p> <p>Combination wrench</p>  <p>Capacity: 17 mm [0.67 in.], 21 mm [0.82 in.], and 32 mm [1.26 in.]</p>
<p>Multimeter</p> 	<p>Marker (diameter \leq 10 mm [0.39 in.])</p> 	<p>Measuring tape</p> 

2.3 Skills and Requirements for Onsite Personnel

Onsite personnel must be qualified and trained. Before performing any operation, onsite personnel must be familiar with correct operation methods and safety precautions.

Before the installation, pay attention to the following items:

- The customer's technical engineers must be trained by Huawei and be familiar with the proper installation and operation methods.
- The number of onsite personnel depends on the engineering schedule and installation environment. Generally, only three to five onsite personnel are necessary.

3 Information About the Installation

About This Chapter

Before installing an RRU, you must be familiar with its exterior, ports, installation options, physical supports, and installation clearance requirements.

[3.1 RRU Exterior](#)

This section describes the exterior and dimensions of an RRU.

[3.2 RRU Ports](#)

This section describes the ports on the remote radio unit (RRU) panels. An RRU has a bottom panel, cabling cavity panel, and indicator panel.

[3.3 RRU Indicators](#)

This section describes six indicators on an RRU. They indicate the running status.

[3.4 Installation Options](#)

This section describes RRU installation options. An RRU can be installed on a pole, U-steel, angle steel, or wall.

[3.5 Installation Clearance Requirements of an RRU](#)

This section describes the requirements for the installation clearance of a single RRU and multiple RRUs and the requirements for the installation spacing between RRUs.

3.1 RRU Exterior

This section describes the exterior and dimensions of an RRU.

Figure 3-1 shows an RRU.

Figure 3-1 RRU exterior

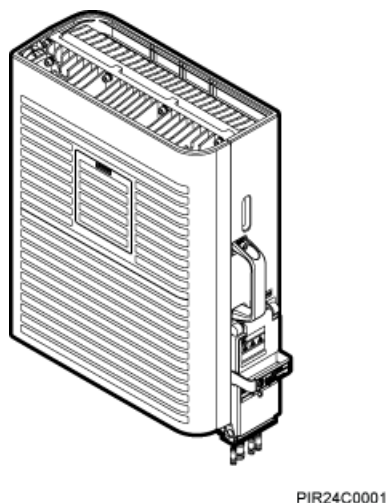
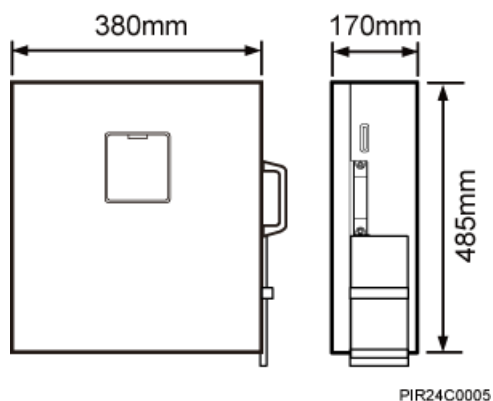

Figure 3-2 shows RRU dimensions.

Figure 3-2 RRU dimensions



3.2 RRU Ports

This section describes the ports on the remote radio unit (RRU) panels. An RRU has a bottom panel, cabling cavity panel, and indicator panel.

Figure 3-3 shows RRU ports on the panels.

Figure 3-3 RRU ports on the panels

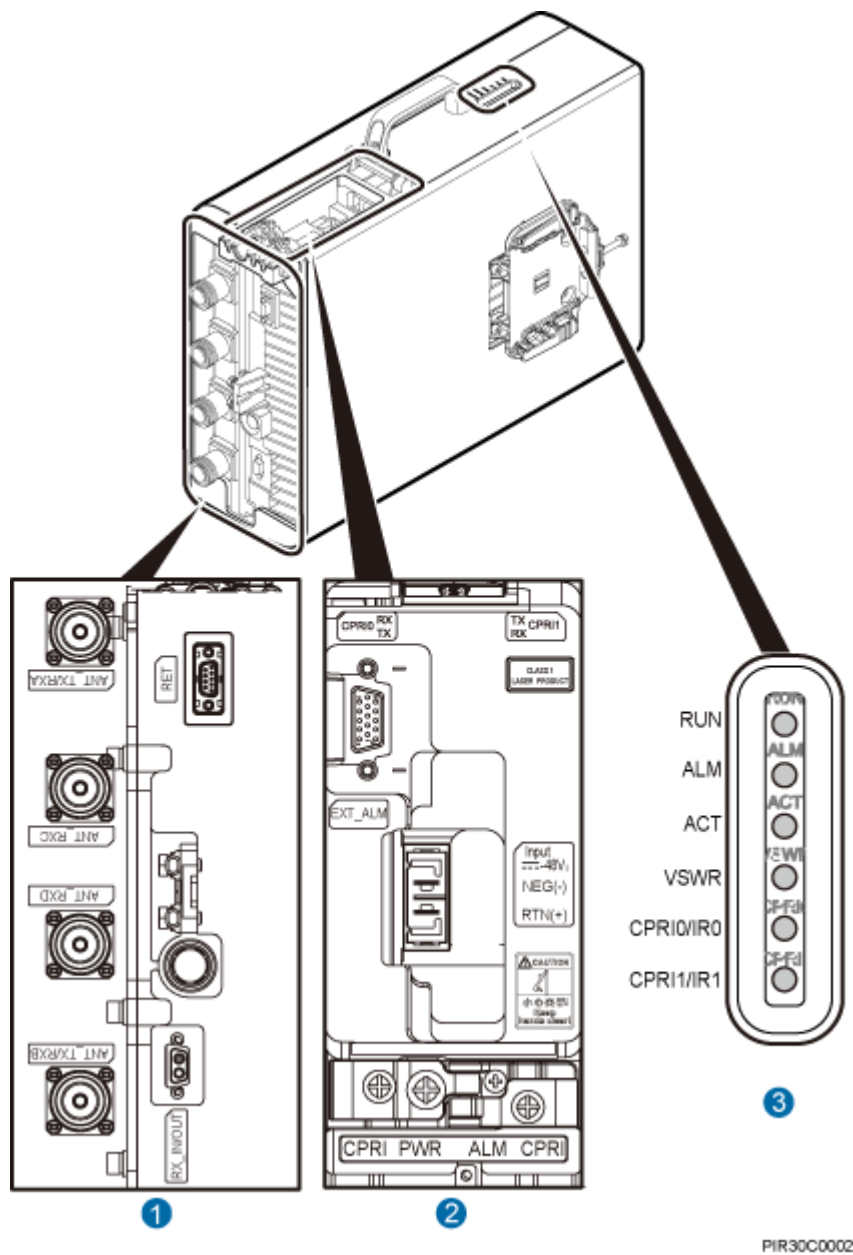

Table 3-1 describes RRU ports and indicators on the panels.

Table 3-1 RRU ports and indicators on the panels

Item	Label	Description
(1) Ports at the bottom	ANT_TX/RXA	TX/RX port A, transmitting remote electrical tilt (RET) signals
	ANT_RXC	RX port C
	ANT_RXD Port	RX port D

Item	Label	Description
	ANT_TX/RXB	TX/RX port B
	RX_IN/OUT	Port for connecting to the inter-RRU radio frequency (RF) cable
	RET	RET antenna port, transmitting RET signals
(2) Ports in the cabling cavity	RTN (+)	Power supply port
	NEG (-)	
	CPRI0	Optical/electrical port 0
	CPRI1	Optical/electrical port 1
	EXT_ALM	Port for alarm reporting
(3) Indicators	RUN	See <i>RRU Indicators</i> .
	ALM	
	ACT	
	VSWR	
	CPRI0/IR0	
	CPRI1/IR1	

 **NOTE**

The port for transmitting RET signals is configured using software.

Table 3-2 lists the combination of RF ports.

Table 3-2 Combination of RF ports

TX/RX Channel	Number of RF Ports	Combination of RF ports
One 1T2R channel	2	Combination of ANT_TX/RXA and ANT_TX/RXA ports
	2	Combination of ANT_TX/RXB and ANT_RXD ports
	2	Combination of ANT_TX/RXA and ANT_RXB ports
Two 1T2R channels	4	Combination of ANT_TX/RXA and ANT_RXC ports and combination of ANT_TX/RXB and ANT_RXD ports

TX/RX Channel	Number of RF Ports	Combination of RF ports
2T2R channel	2	Combination of ANT_TX/RXA and ANT_TX/RXB ports

3.3 RRU Indicators

This section describes six indicators on an RRU. They indicate the running status.

For detailed positions of RRU indicators, see RRU Ports.

Table 3-3 describes RRU indicators.

Table 3-3 RRU indicators

Label	Color	Status	Description
RUN	Green	On	There is power supply, but the module is faulty.
		Off	There is no power supply, or the module is faulty.
		Blinking (on for 1s and off for 1s)	The module is working properly.
		Blinking (on for 0.125s and off for 0.125s)	Software is being loaded to the module, or the module is not started.
ALM	Red	On	Alarms are generated, and the module must be replaced.
		Blinking (on for 1s and off for 1s)	Alarms are generated. The alarms may be caused by the faults on the related boards or ports. Therefore, the necessity for module replacement is uncertain.
		Off	No alarm is generated.
ACT	Green	On	The module is working properly with TX channels enabled.
		Blinking (on for 1s and off for 1s)	The module is working properly with TX channels disabled.
VSWR	Red	Off	No VSWR alarm is generated.
		Blinking (on for 1s and off for 1s)	VSWR alarms are generated on the ANT_TX/RXB port.
		On	VSWR alarms are generated on the ANT_TX/RXA port.

Label	Color	Status	Description
		Blinking (on for 0.125s and off for 0.125s)	VSWR alarms are generated on the ANT_TX/RXA and ANT_TX/RXB ports.
CPRI0/IR0	Red and green	Steady green	The CPRI link is available.
		Steady red	An optical module fails to transmit or receive signals because the optical module is faulty or the fiber optic cable is broken.
		Blinking red (on for 1s and off for 1s)	The CPRI link is out of lock because of mutual lock of dual-mode clock sources or mismatched data rates over CPRI ports (you are advised to check the system configuration to identify the fault).
		Off	The SFP module is not properly installed, or the optical module is powered off.
CPRI1/IR1	Red and green	Steady green	The CPRI link is available.
		Steady red	An optical module fails to transmit or receive signals because the optical module is faulty or the fiber optic cable is broken.
		Blinking red (on for 1s and off for 1s)	The CPRI link is out of lock because of mutual lock of dual-mode clock sources or mismatched data rates over CPRI ports (you are advised to check the system configuration to identify the fault).
		Off	The SFP module is not properly installed, or the optical module is powered off.

3.4 Installation Options

This section describes RRU installation options. An RRU can be installed on a pole, U-steel, angle steel, or wall.

Installing an RRU on a Pole

Figure 3-4 shows the diameter of pole for installing an AAU3801.

Figure 3-4 Diameter of a pole

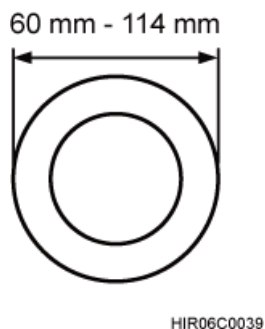

CAUTION

- The diameter of a pole for installing an RRU ranges from 60 mm (2.36 in.) to 114 mm (4.49 in.). The recommended diameter is 80 mm (3.15 in.).
- If the diameter of a pole ranges from 60 mm (2.36 in.) to 76 mm (2.99 in.), a maximum of two RRUs can be installed on the pole and the side-mounted installation is not recommended.

Figure 3-5 shows an RRU installed on a pole.

Figure 3-5 RRU installed on a pole

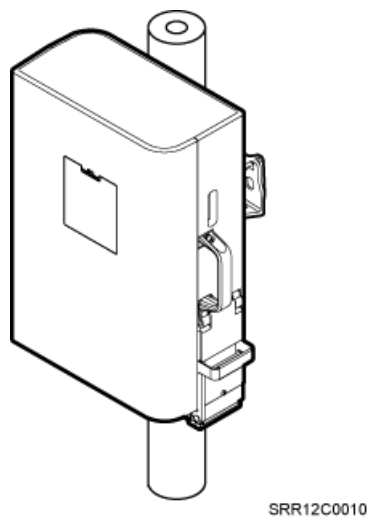

Installing an RRU on U-steel

Figure 3-6 shows U-steel specifications.

Figure 3-6 U-steel specifications

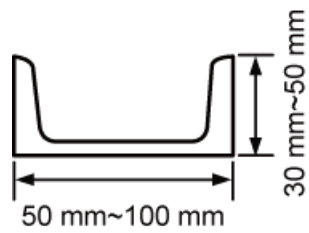

HIR06C0037



CAUTION

- It is recommended that only one RRU be installed on U-steel.
- The vertical deviation angle of U-steel must be less than or equal to 10 degrees, as shown in [Figure 3-7](#).

Figure 3-7 Requirements for the vertical deviation angle of U-steel or angle steel

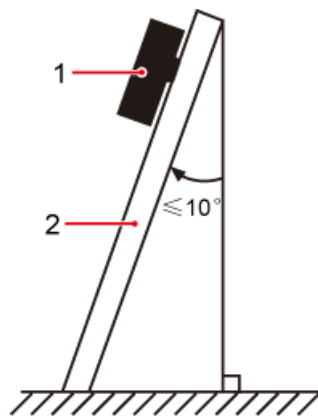

HIR06C0002

(1) RRU

(2) U-steel or angle steel

[Figure 3-8](#) shows an RRU installed on U-steel.

Figure 3-8 RRU installed on U-steel

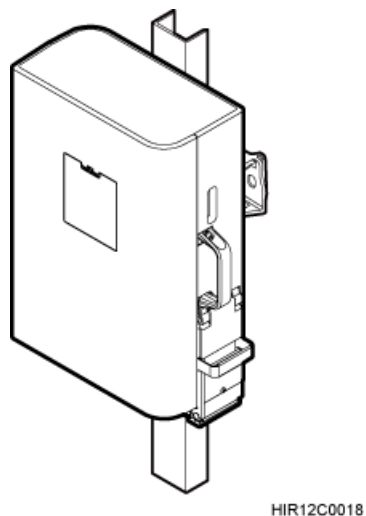

Installing an RRU on Angle Steel

Figure 3-9 shows angle steel specifications.

Figure 3-9 Angle steel specifications

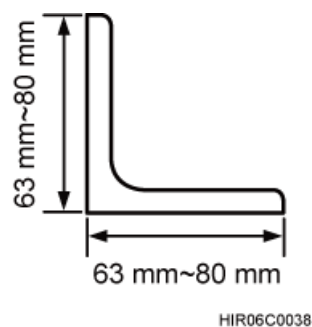

CAUTION

- It is recommended that only one RRU be installed on angle steel.
- The vertical deviation angle of angle steel must be less than or equal to 10 degrees, as shown in **Figure 3-7**.

Figure 3-10 shows an RRU installed on angle steel.

Figure 3-10 RRU installed on angle steel

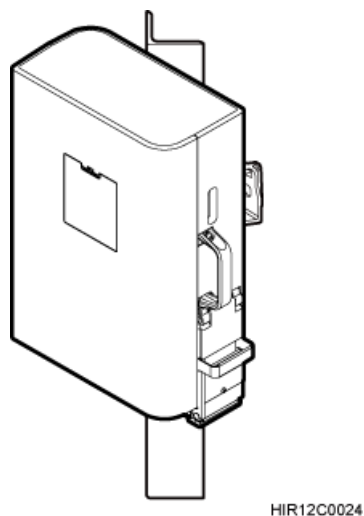

Installing an RRU on a Wall

The wall on which RRUs are installed must meet the following requirements:

- When a single RRU is installed, the wall has a capacity of bearing at least four times the weight of the RRU.
- Expansion bolts must be tightened to 30 N·m (265.52 lbf·in.) to ensure the bolts work properly and the wall remains intact without cracks in it.



CAUTION

The brackets cannot be combined when RRUs are installed on a wall, as shown in [Figure 3-11](#).

Figure 3-11 Correct placement of brackets

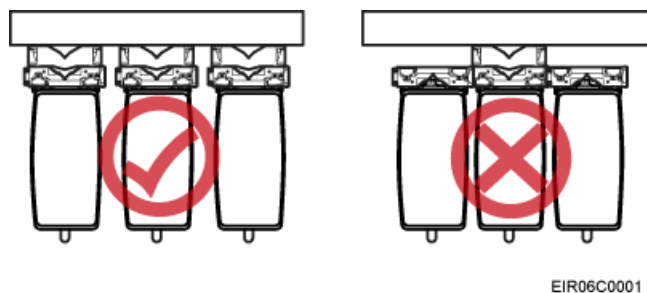

[Figure 3-12](#) shows an RRU installed on a wall.

Figure 3-12 RRU installed on a wall

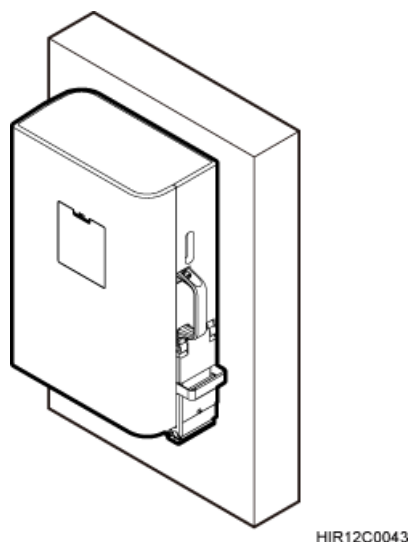

3.5 Installation Clearance Requirements of an RRU

This section describes the requirements for the installation clearance of a single RRU and multiple RRUs and the requirements for the installation spacing between RRUs.

 **NOTE**

The recommended installation clearance ensures normal running and provides an appropriate space for Operation and Maintenance (O&M). If there is sufficient space, leave the recommended installation clearance.

The minimum installation clearance ensures normal running and heat dissipation, but OM activities such as checking indicator status and opening the maintenance cavity cannot be properly conducted. If the installation space is restricted, leave the minimum installation clearance.

3.5.1 Installation Clearance for a Single RRU

This section describes the recommended and minimum installation clearance for a single RRU.

Recommended Installation Clearance for a Single RRU

Figure 3-13 shows the recommended installation clearance for a single RRU.

Figure 3-13 Recommended installation clearance for a single RRU

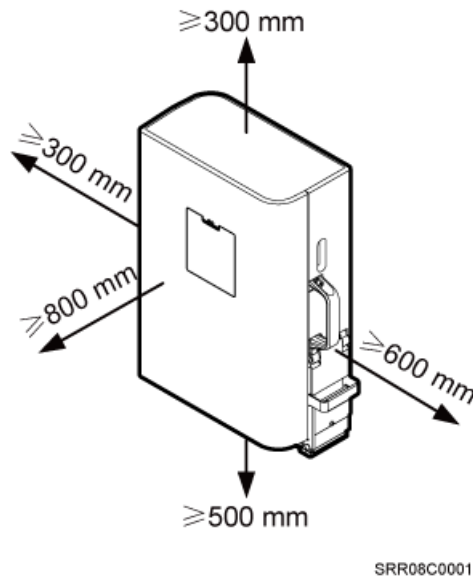

Minimum Installation Clearance for a Single RRU

Figure 3-14 shows the minimum installation clearance for a single RRU.

Figure 3-14 Minimum installation clearance for a single RRU

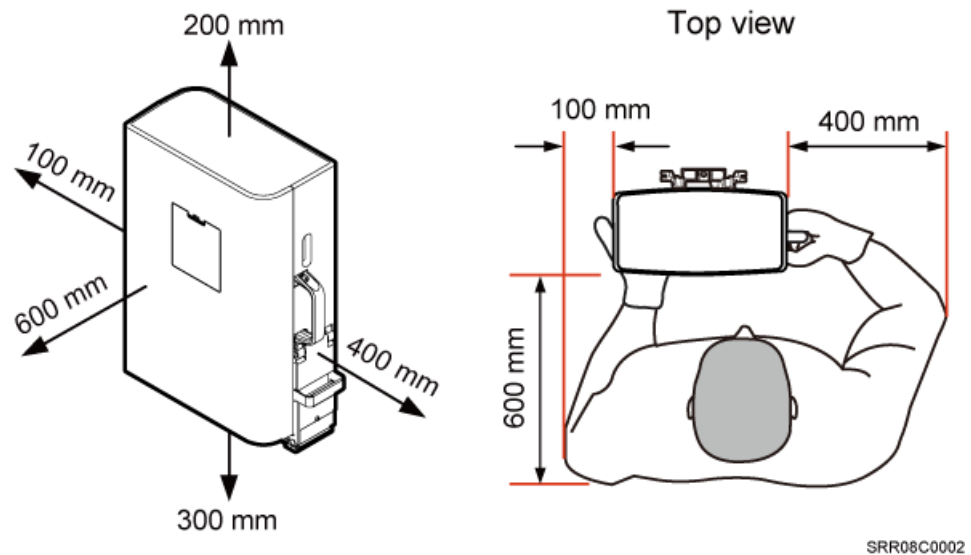

Minimum Installation Clearance for a Single RRU Installed on a Tower

Figure 3-15 shows the minimum installation clearance for a single RRU installed on a tower.

Figure 3-15 Minimum installation clearance for a single RRU installed on a tower

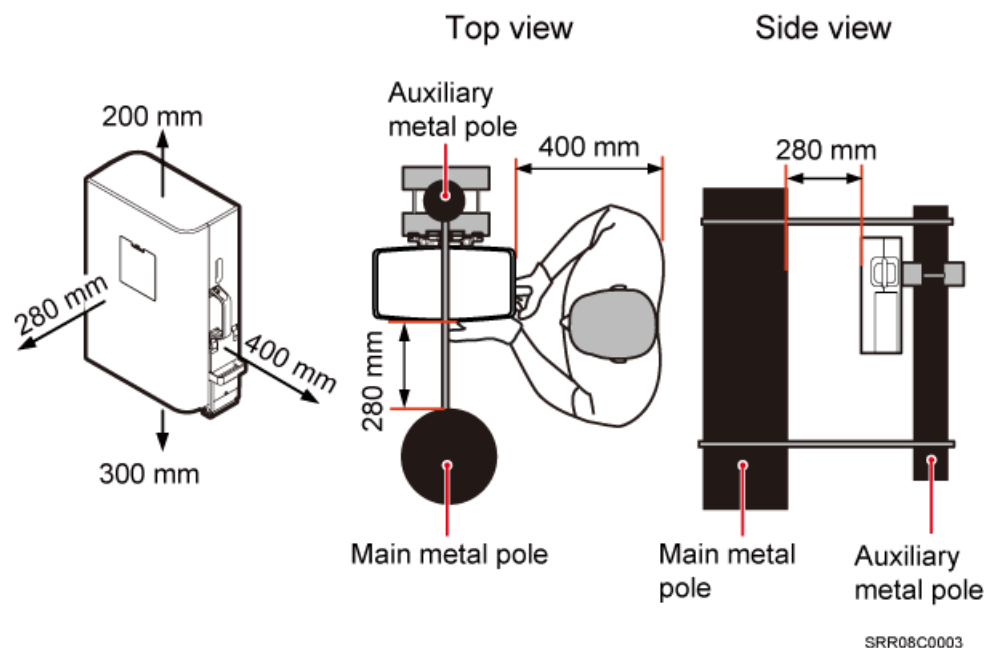

3.5.2 Installation Clearance for Multiple RRUs

This section describes the recommended and minimum installation clearance for multiple RRUs.

Recommended Installation Clearance for Multiple RRUs Installed in Centralized Mode

Figure 3-16 shows the recommended installation clearance for multiple RRUs installed in centralized mode.

Figure 3-16 Recommended installation clearance for multiple RRUs installed in centralized mode

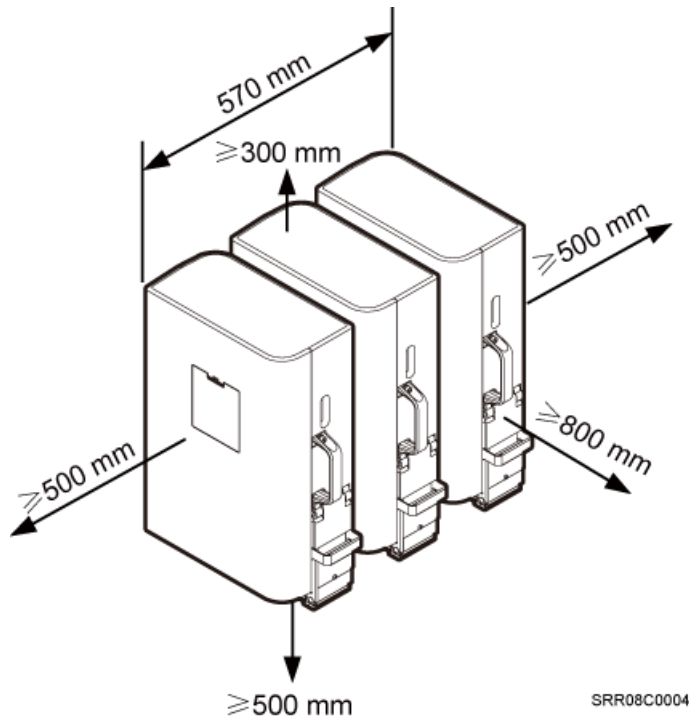

Minimum Installation Clearance for Multiple RRUs Installed in Centralized Mode

Figure 3-17 shows the minimum installation clearance for multiple RRUs installed in centralized mode.

Figure 3-17 Minimum installation clearance for multiple RRUs installed in centralized mode

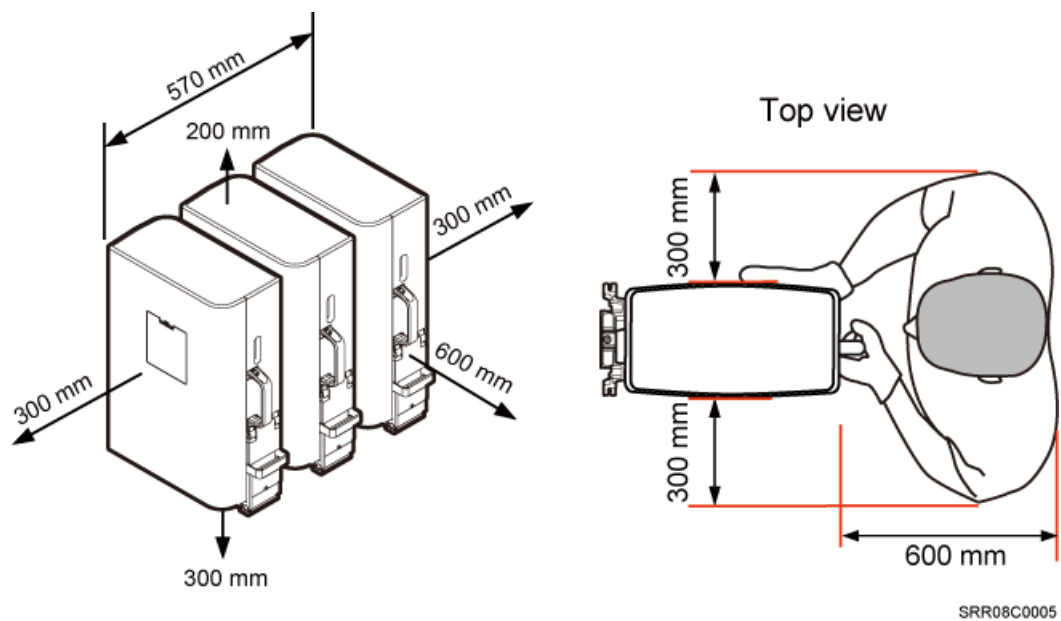

Recommended Clearance for Multiple RRUs Installed on a Wall in Standard Mode

Figure 3-18 shows the recommended clearance for multiple RRUs installed on a wall in standard mode.

Figure 3-18 Recommended clearance for multiple RRUs installed on a wall in standard mode

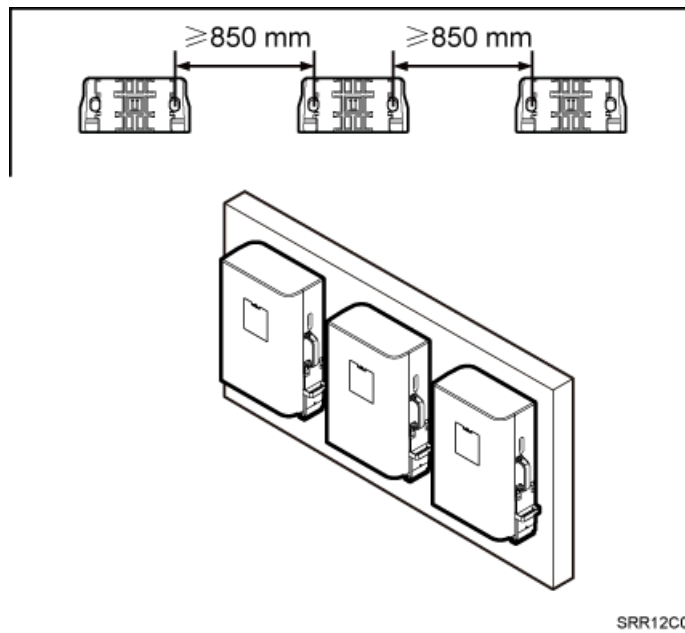

Minimum Clearance for Multiple RRUs Installed on a Wall in Standard Mode

Figure 3-19 shows the minimum clearance for multiple RRUs installed on a wall in standard mode.

Figure 3-19 Minimum clearance for multiple RRUs installed on a wall in standard mode

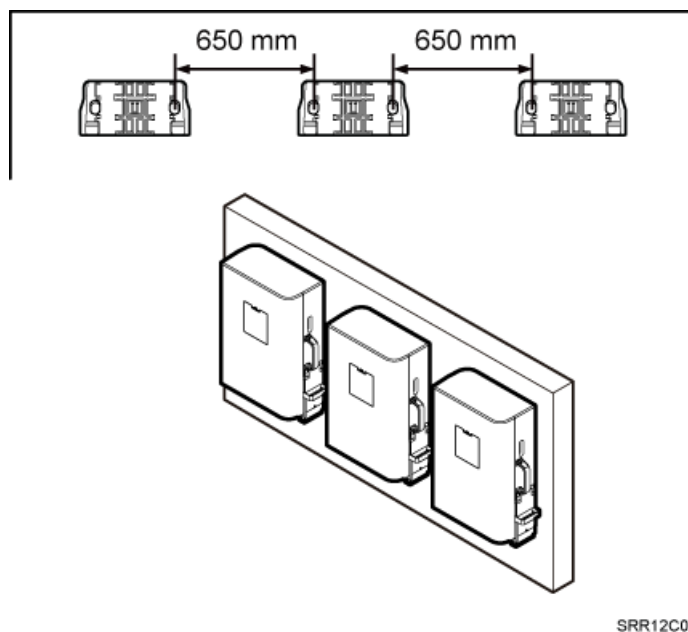

SRR12C0016

Recommended Clearance for Multiple RRUs Side-Mounted on a Wall

Figure 3-20 shows the recommended clearance for multiple RRUs side-mounted on a wall.

Figure 3-20 Recommended clearance for multiple RRUs side-mounted on a wall

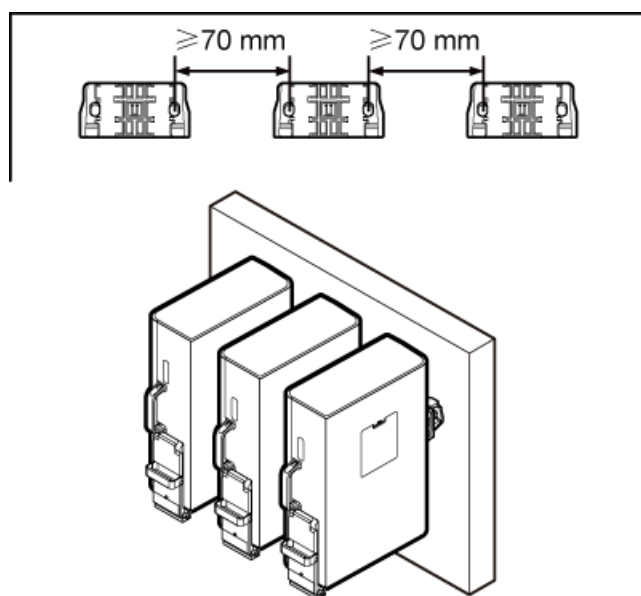

SRR12C0017

3.5.3 Installation Spacing Between RRUs

This section describes the horizontal and vertical installation spacing between RRUs.

Recommended Horizontal Spacing Between RRUs

Figure 3-21 shows the recommended horizontal spacing between RRUs.

Figure 3-21 Recommended horizontal spacing between RRUs

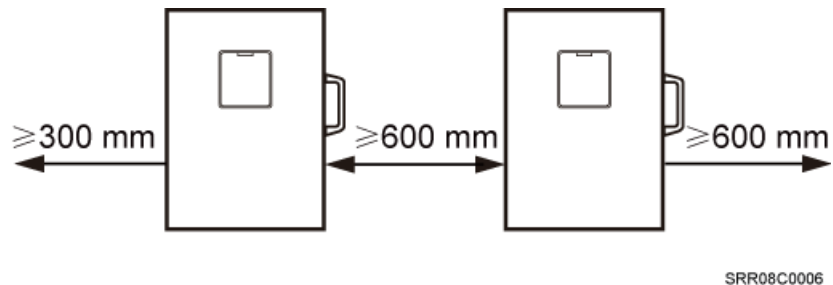

Minimum Horizontal Spacing Between RRUs

Figure 3-22 shows the minimum horizontal spacing between RRUs.

Figure 3-22 Minimum horizontal spacing between RRUs

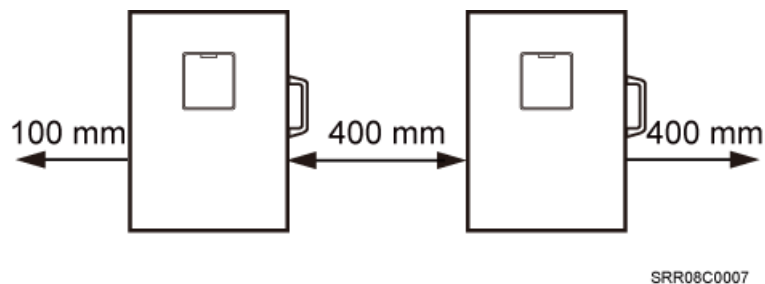

Recommended Vertical Spacing Between RRUs

Figure 3-23 shows the recommended vertical spacing between RRUs.

Figure 3-23 Recommended vertical spacing between RRUs

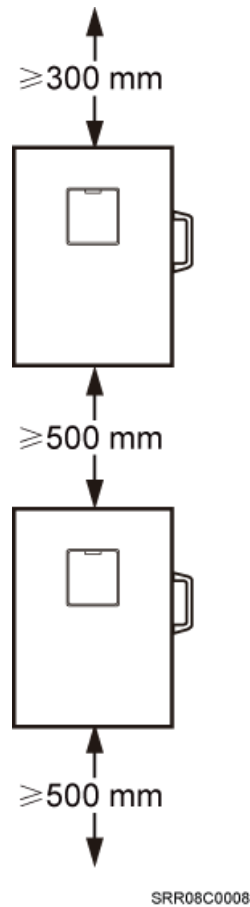

Minimum Vertical Spacing Between RRUs

Figure 3-24 shows the minimum vertical spacing between RRUs.

Figure 3-24 Minimum vertical spacing between RRUs

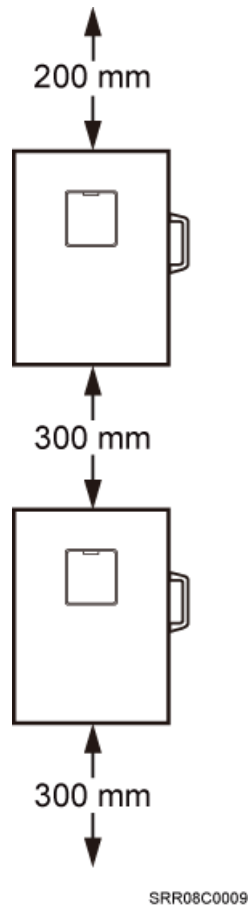

4 Unpacking the Equipment

Unpack and check the delivered equipment to ensure that all the materials are included and intact.

Context

 **NOTE**

When transporting, moving, or installing the equipment, components, or parts, you must:

- Prevent them from colliding with doors, walls, shelves, or other objects.
- Wear clean gloves, and avoid touching the equipment, components, or parts with bare hands, sweat-soaked gloves, or dirty gloves.



CAUTION

- After a cabinet or an BBU is unpacked, it must be powered on within 7 days.
- After an RRU is unpacked, it must be powered on within 24 hours.

Procedure

Step 1 Check the total number of articles in each case according to the packing list.

If ...	Then ...
The total number tallies with the packing list	Go to Step 2 .
The total number does not tally with the packing list	Find out the cause and report any missing articles to the local Huawei office.

Step 2 Check the exterior of the packing case.

If ...	Then ...
The outer packing is intact	Go to Step 3 .
The outer packing is severely damaged or soaked	Find out the cause and report it to the local Huawei office.
The vibrating indicator is red	Stop unpacking the wooden crate, and then report it to the transportation company.

Step 3 Check the type and quantity of the equipment in the cases according to the packing list.

If ...	Then ...
Types and quantity of the article tally with those on the packing list	Sign the <i>Packing List</i> with the customer.
There is any shipment shortage or wrong shipment	Fill in and submit the <i>Cargo Shortage and Mishandling Report</i> .
Articles are damaged.	Fill in and submit the <i>Article Replacement Report</i> .



WARNING

To protect the equipment and prevent damage to the equipment, you are advised to keep the unpacked equipment and packing materials indoors, take photos of the stocking environment, packing case or carton, packing materials, and any rusted or eroded equipment, and then file the photos.

----End

5 Installation Process

The installation process involves installing an RRU and RRU cables, checking the RRU hardware installation, and powering on the RRU.

Figure 5-1 shows the process of installing an RRU.

Figure 5-1 Process of installing an RRU

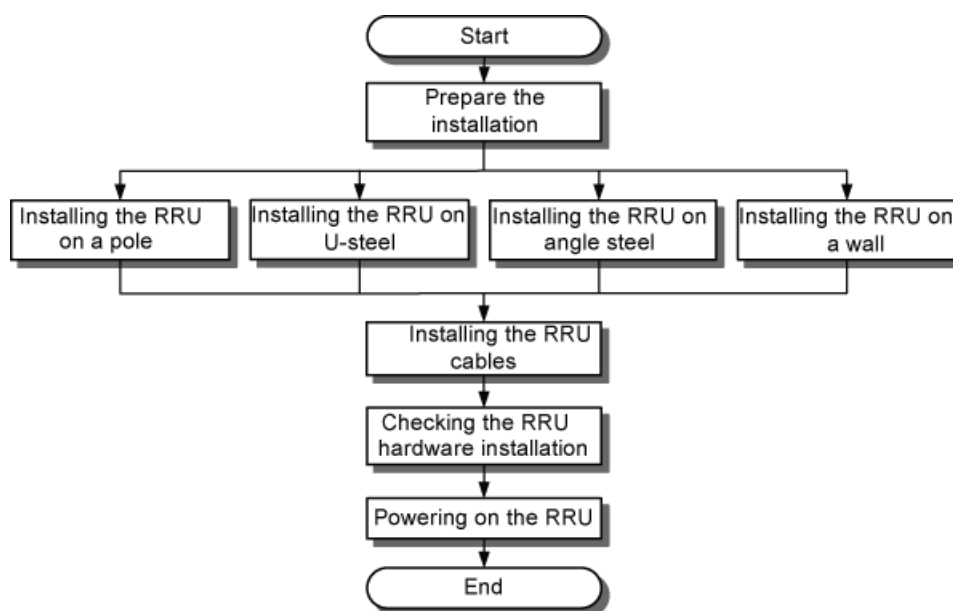

IPR06C0001

6 Installing the RRU

About This Chapter

This chapter describes the procedure for installing the RRU. The RRU can be installed on a pole, U-steel, angle steel, or wall. The procedure for installing the RRU varies depending on installation options.



CAUTION

- Do not stand the RRU upright because the load-bearing capacity of the RF ports at the RRU bottom is low.
 - Place a foam pad or cardboard under an RRU to protect the RRU housing from damage during the installation.
-

[6.1 Mounting Kits for an RRU](#)

This section describes the bracket assembly and the attachment plate for an RRU.

[6.2 Installing the RRU on a Pole](#)

One or more RRUs can be installed on a pole.

[6.3 Installing the RRU on U-steel](#)

This section describes the procedure for installing the RRU on U-steel and the precautions that must be taken during the installation. The RRU installed on U-steel can be mounted to a tower or placed on the ground. It is recommended that only one RRU be installed on U-steel.

[6.4 Installing the RRU on Angle Steel](#)

This section describes the procedure for installing the RRU on angle steel and the precautions that must be taken during the installation. The RRU installed on angle steel can be mounted to a tower or placed on the ground. It is recommended that only one RRU be installed on angle steel.

[6.5 Installing the RRU on a Wall](#)

This section describes the procedure for installing the RRU on a wall and the precautions that must be taken during the installation.

[6.6 Hoisting an RRU onto a Tower](#)

Before installing an RRU on a tower, bind the RRU and mounting kits and then hoist them onto the tower. The RRU can be installed on a pole, U-steel, or angle steel. This section describes the procedure for hoisting the RRU and mounting kits onto the tower and the precautions that must be taken.

6.1 Mounting Kits for an RRU

This section describes the bracket assembly and the attachment plate for an RRU.

Figure 6-1 shows the front and rear view of an RRU.

Figure 6-1 Front and rear view of an RRU

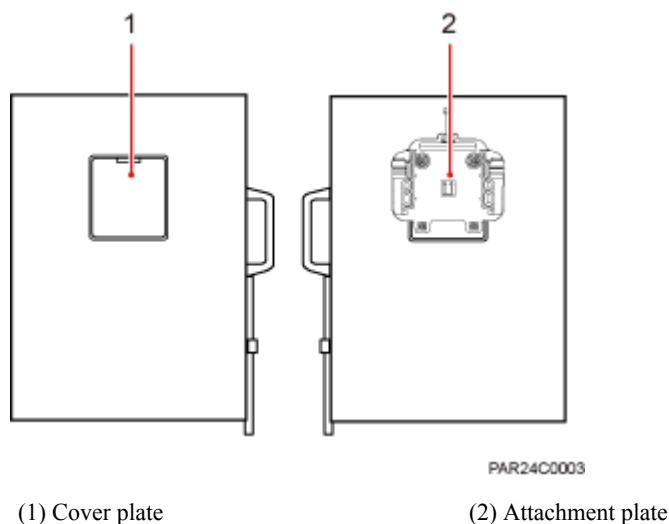
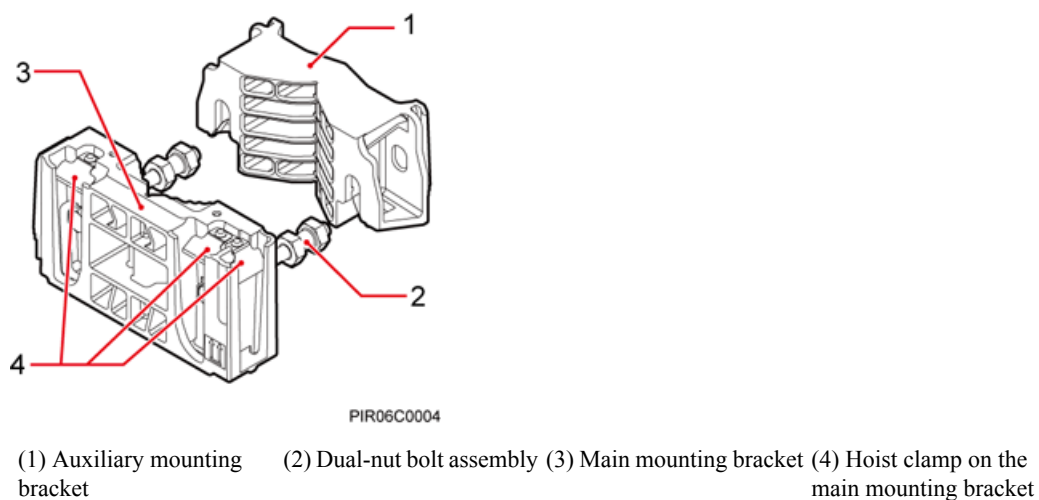

Figure 6-2 shows the bracket assembly for an RRU.

Figure 6-2 Bracket assembly for an RRU



6.2 Installing the RRU on a Pole

One or more RRUs can be installed on a pole.

Figure 6-3 shows a single RRU installed on a pole.

Figure 6-3 A single RRU installed on a pole

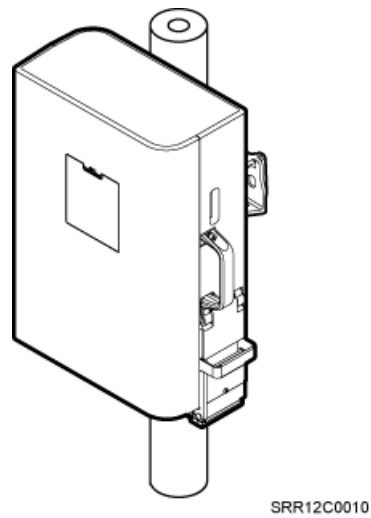

Figure 6-4 shows two RRUs installed on a pole.

Figure 6-4 Two RRUs installed on a pole

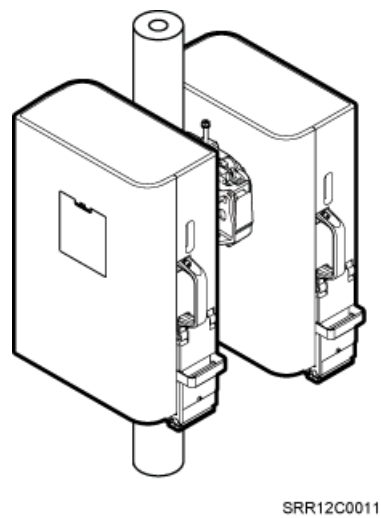

Figure 6-5, **Figure 6-6**, and **Figure 6-7** show more than two RRUs installed on a pole.

Figure 6-5 Three RRUs installed on a pole in centralized mode

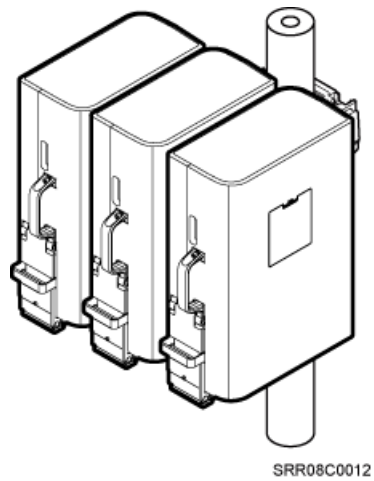

Figure 6-6 Four RRUs installed on a pole in centralized mode

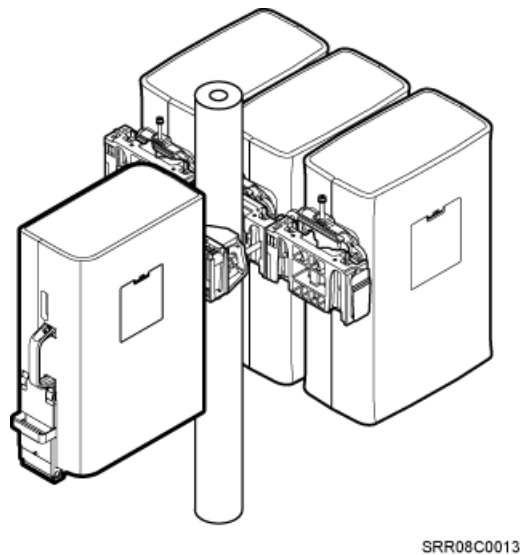
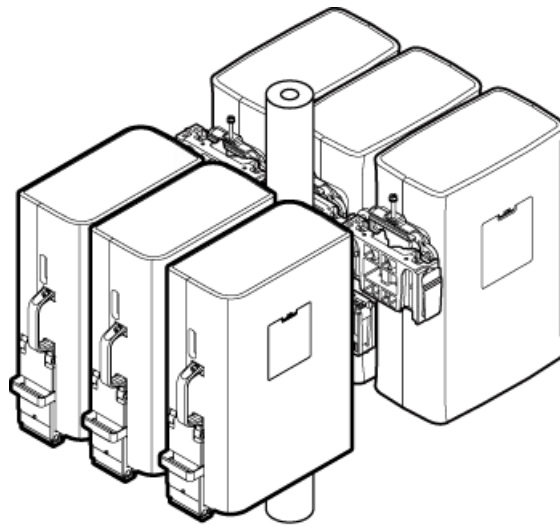

Figure 6-7 Six RRUs installed on a pole in centralized mode



SRR08C0014

6.2.1 Installing a Single RRU

This section describes the procedure for installing a single RRU on a pole and the precautions that must be taken during the installation.

Prerequisite

Before you install an RRU on a tower, the RRU and mounting kits are hoisted onto the tower. For details, see [6.6 Hoisting an RRU onto a Tower](#).

The hoist clamp on the main mounting bracket is secured properly.

Procedure

- Step 1** Determine a position for installing the main mounting bracket.
- If the RRU must be installed on a tower, see [3.5.1 Installation Clearance for a Single RRU](#) to determine a position.
 - If the RRU must be installed on the ground, see [Figure 6-8](#) to determine a position.

Figure 6-8 Distance between the main mounting bracket and the ground

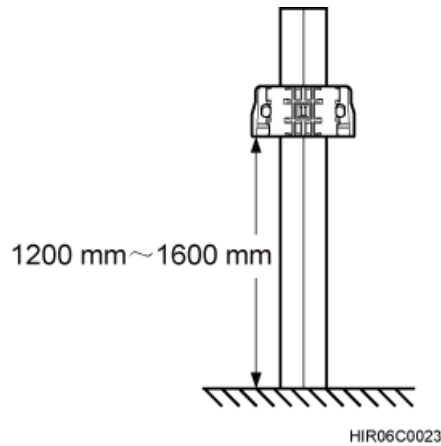

- Step 2** Fit one end of the auxiliary mounting bracket to one dual-nut bolt assembly of the main mounting bracket.
- Step 3** Install the bracket assembly on the pole, and then fit the other end of the auxiliary mounting bracket to the other dual-nut bolt assembly, as shown in [Figure 6-9](#).

Figure 6-9 Installing the bracket assembly

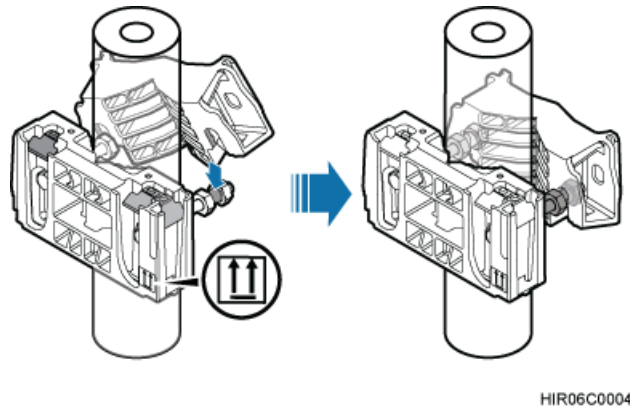

 **NOTE**

Verify that the arrow on the main mounting bracket is pointing up.

- Step 4** Using a torque wrench, tighten the nuts to 40 N·m (354.03 lbf·in.) to secure the bracket assembly onto the pole, as shown in [Figure 6-10](#).

 **CAUTION**

Tighten the two dual-nut bolt assemblies alternatively. After the main and auxiliary brackets are secured properly, measure the spacing between the brackets on both sides and ensure that the spacing is the same on the two sides.

Figure 6-10 Securing the bracket assembly onto the pole

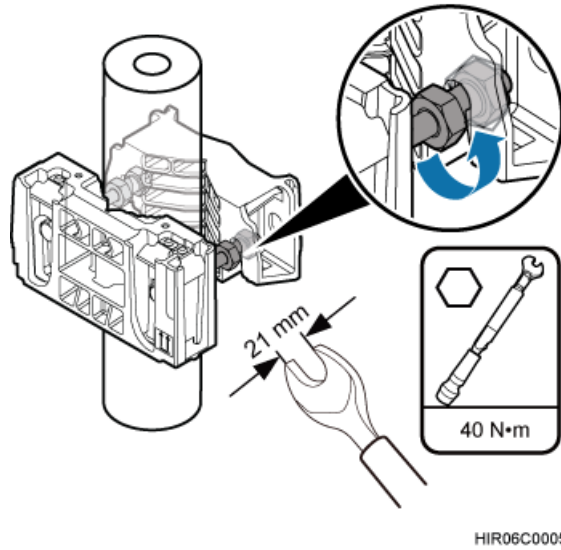

Step 5 Install the RRU on the main mounting bracket until the RRU snaps shut, as shown in **Figure 6-11**.

Figure 6-11 Installing the RRU on the main mounting bracket

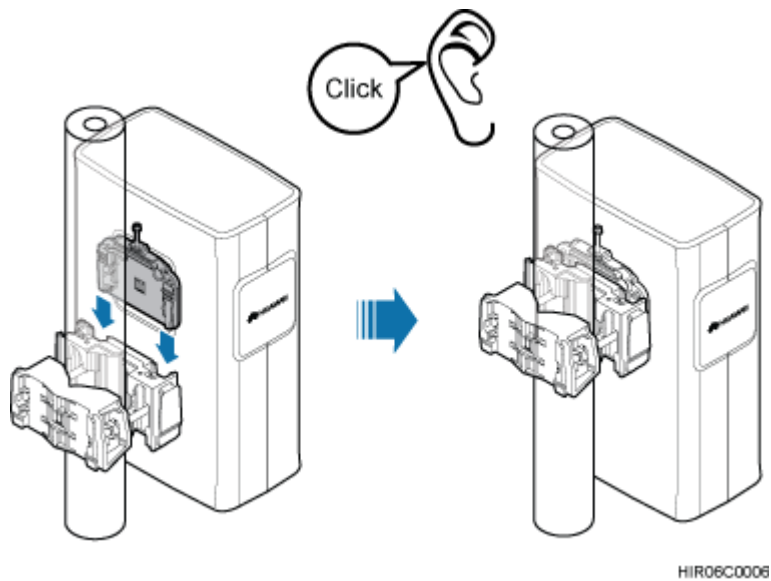

---End

6.2.2 Installing Two RRUs

This section describes the procedure for installing two RRUs on a pole and the precautions that must be taken during the installation.

Procedure

- Step 1** Install the first RRU, as shown in [Figure 6-12](#). For details, see [6.2.1 Installing a Single RRU](#).

Figure 6-12 Installing the first RRU

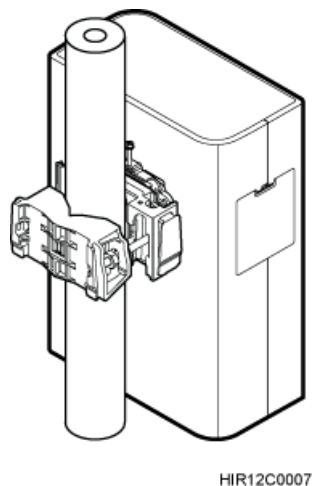

- Step 2** Install the other main mounting bracket on the auxiliary mounting bracket to secure the second RRU, as shown in [Figure 6-13](#).

Figure 6-13 Installing the second main mounting bracket

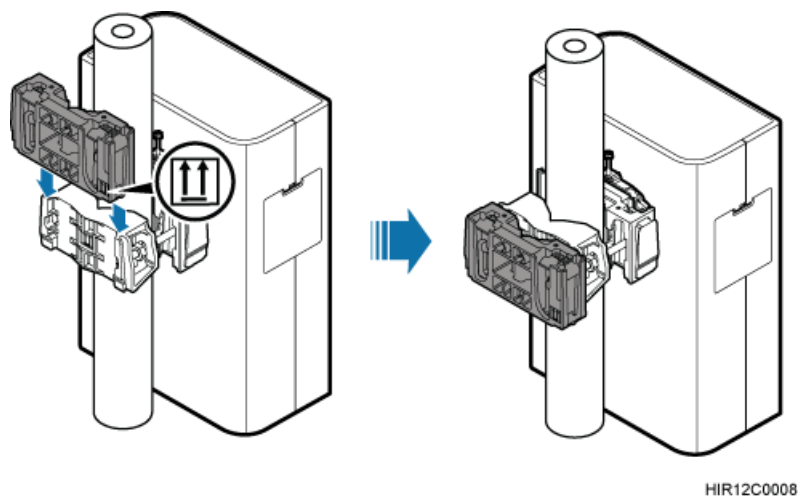

- Step 3** Interchange the cover plate and plastic screws in the front and the attachment plate and stainless steel screws at the rear of the second RRU, as shown in [Figure 6-14](#).

Figure 6-14 Interchanging the cover plate in the front and the attachment plate at the rear of the second RRU

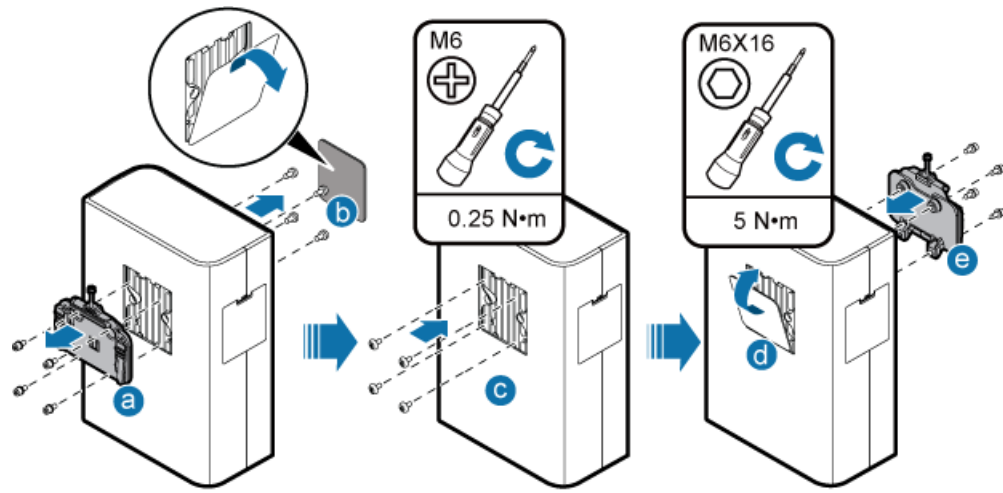

HIR20C0009

1. Remove the attachment plate from the RRU rear using an inner hexagon screwdriver.
2. Remove the cover plate from the RRU front, and use a Phillips screwdriver to remove the plastic screws from the RRU.
3. Install the plastic screws onto the RRU rear, and tighten the screws to 0.25 N·m (2.21 lbf·in.) using a torque screwdriver.
4. Install the cover plate onto the RRU rear.
5. Install the attachment plate onto the RRU front, and tighten the stainless steel screws on the attachment plate to 5 N·m (44.25 lbf·in.) using a torque screwdriver.

Step 4 Install the second RRU on the main mounting bracket, as shown in [Figure 6-15](#).

Figure 6-15 Installing the second RRU on the main mounting bracket

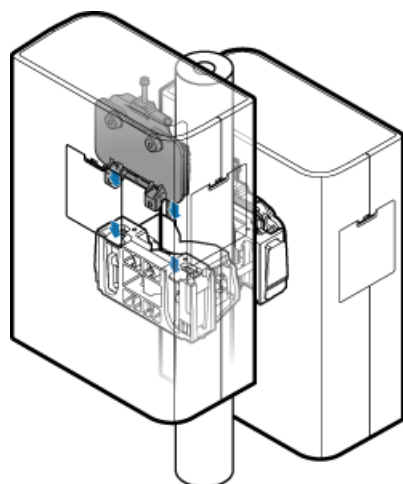

HIR08C0010

---End

6.2.3 Installing Multiple RRUs

The section describes the procedure for installing multiple RRUs on a pole and the precautions that must be taken during the installation.

Context

A pole supports the installation of three, four, or six RRUs. The procedures for installing them are the same. Following is the procedure of installing four RRUs on a pole.

Procedure

- Step 1** Install one set of bracket assembly on a pole. For details, see [6.2.1 Installing a Single RRU](#).
- Step 2** Interchange the attachment plate and stainless steel screws at the RRU rear and the cover plate and plastic screws on the RRU side, as shown in [Figure 6-16](#).

Figure 6-16 Interchanging the attachment plate at the RRU rear and the cover plate on the RRU side

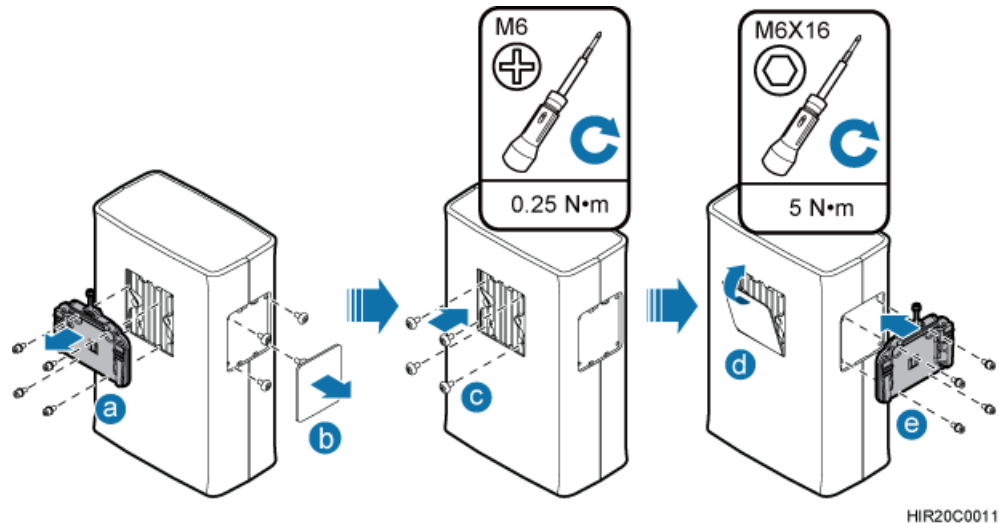

1. Remove the attachment plate from the RRU rear using an inner hexagon screwdriver.
2. Remove the cover plate from the RRU side, and use a Phillips screwdriver to remove the plastic screws from the RRU.
3. Install the plastic screws onto the RRU rear, and tighten the screws to 0.25 N·m (2.21 lbf·in.) using a torque screwdriver.
4. Install the cover plate onto the RRU rear.
5. Install the attachment plate onto the RRU side, and tighten the stainless steel screws on the attachment plate to 5 N·m (44.25 lbf·in.) using a torque screwdriver.

- Step 3** Install the first RRU on the main mounting bracket, as shown in [Figure 6-17](#).

Figure 6-17 Installing the first RRU on the main mounting bracket

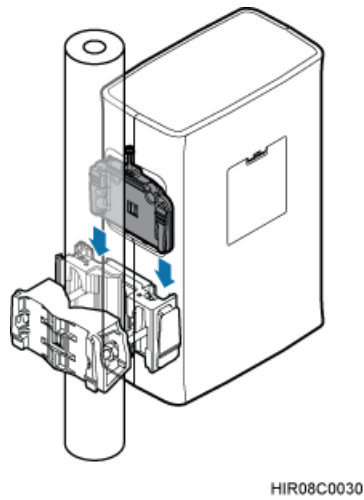

Step 4 Install the second main mounting bracket on the side of the first main mounting bracket, as shown in [Figure 6-18](#).

Figure 6-18 Installing the second main mounting bracket

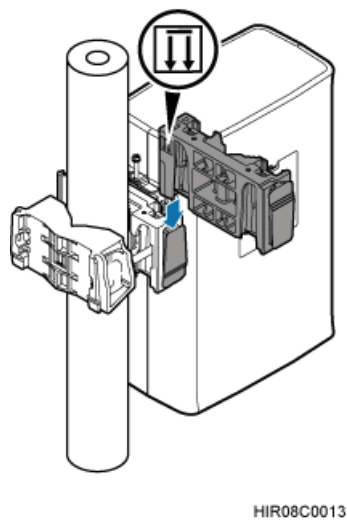

Step 5 Install the second RRU on the second main mounting bracket, as shown in [Figure 6-19](#).

Figure 6-19 Installing the second RRU on the second main mounting bracket

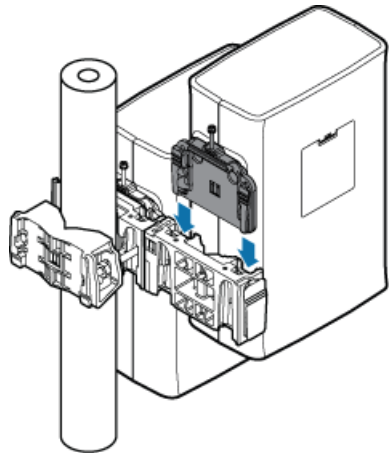

HIR08C0014

Step 6 Install the third main mounting bracket, and then install the third RRU on the main mounting bracket, as shown in [Figure 6-20](#).

Figure 6-20 Installing the third RRU on the third main mounting bracket

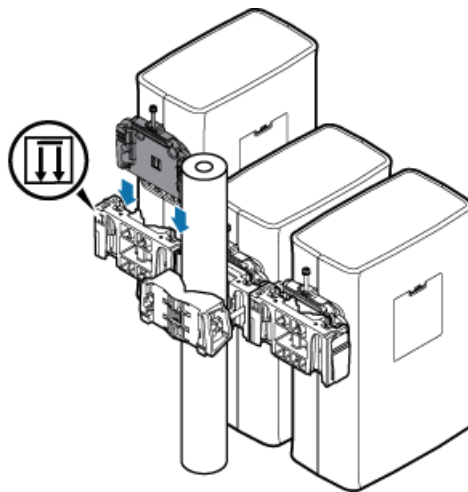

HIR08C0015

Step 7 Install the fourth main mounting bracket, as shown in [Figure 6-21](#).

Figure 6-21 Installing the fourth main mounting bracket

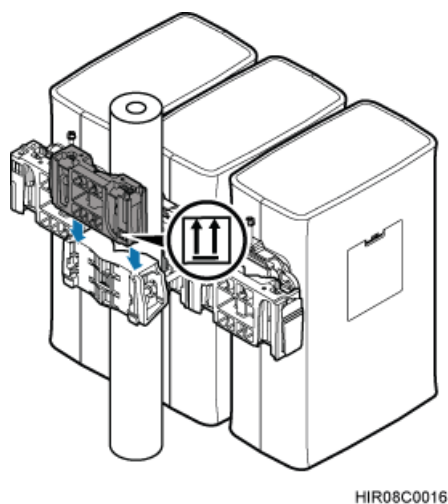

Step 8 Install the fourth RRU on the fourth main mounting bracket, as shown in [Figure 6-22](#).

Figure 6-22 Installing the fourth RRU on the fourth main mounting bracket

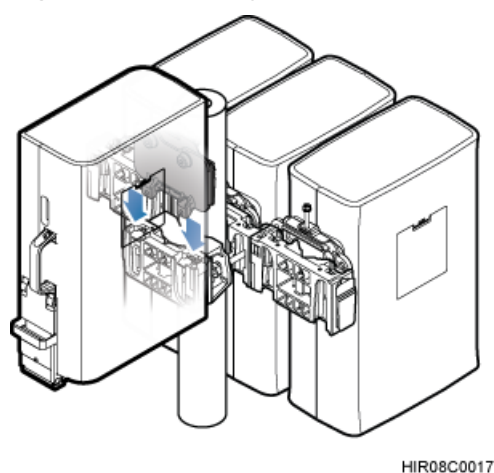

----End

6.3 Installing the RRU on U-steel

This section describes the procedure for installing the RRU on U-steel and the precautions that must be taken during the installation. The RRU installed on U-steel can be mounted to a tower or placed on the ground. It is recommended that only one RRU be installed on U-steel.

Prerequisite

Before you install an RRU on a tower, the RRU and mounting kits are hoisted onto the tower. For details, see [6.6 Hoisting an RRU onto a Tower](#).

The hoist clamp on the main mounting bracket is secured properly.

Context

Figure 6-23 shows the top view of the RRU installed on U-steel.

Figure 6-23 Top view of the RRU

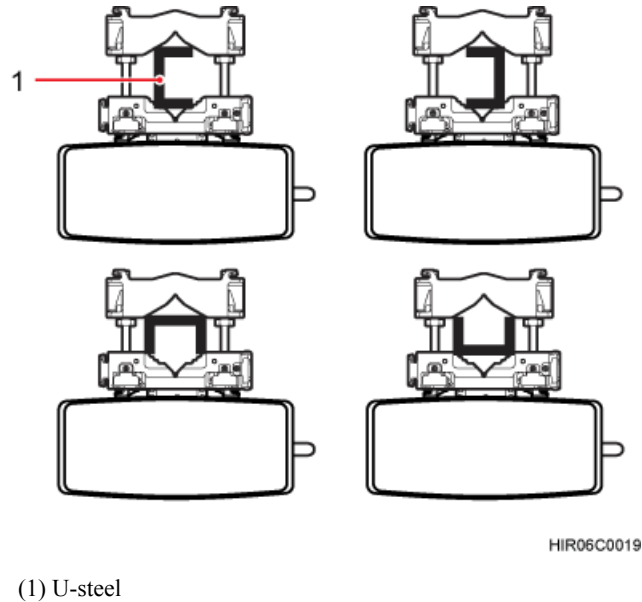

Procedure

- Step 1** Determine a position for installing the main mounting bracket.
- If the RRU must be installed on a tower, see **3.5.1 Installation Clearance for a Single RRU** to determine a position.
 - If the RRU must be installed on the ground, see **Figure 6-24** to determine a position.

Figure 6-24 Distance between the main mounting bracket and the ground

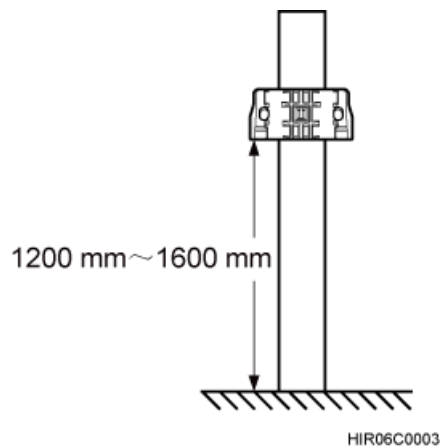

 **NOTE**

It is recommended that the main mounting bracket be 1,200 mm (47.24 in.) to 1,600 mm (62.99 in.) above the ground.

- Step 2** Fit one end of the auxiliary mounting bracket to one dual-nut bolt assembly of the main mounting bracket.
- Step 3** Install the bracket assembly on U-steel, and then fit the other end of the auxiliary mounting bracket to the other dual-nut bolt assembly, as shown in [Figure 6-25](#).

Figure 6-25 Installing the bracket assembly

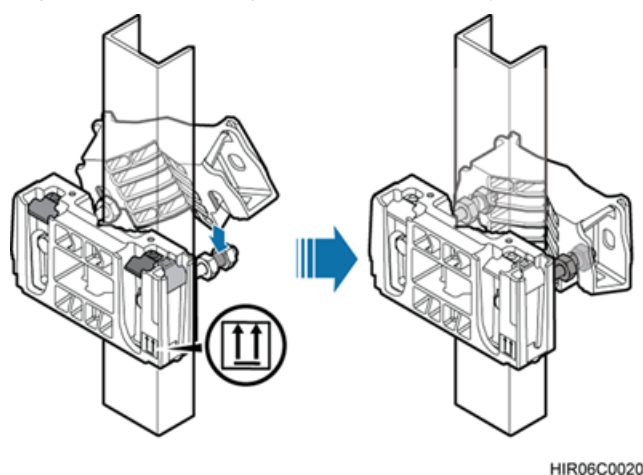

 **NOTE**

Verify that the arrow on the main mounting bracket is pointing up.

- Step 4** Using a torque wrench, tighten the nuts to 40 N·m (354.03 lbf·in.) to secure the bracket assembly onto the U-steel, as shown in [Figure 6-26](#).

 **CAUTION**

Tighten the two dual-nut bolt assemblies alternatively. After the main and auxiliary brackets are secured properly, measure the spacing between the brackets on both sides and ensure that the spacing is the same on the two sides.

Figure 6-26 Securing the bracket assembly onto U-steel

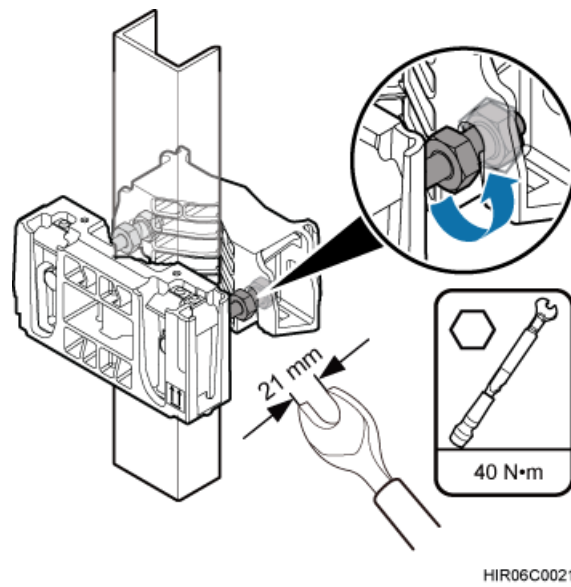

Step 5 Install the RRU on the main mounting bracket until the RRU snaps shut, as shown in **Figure 6-27**.

Figure 6-27 Installing the RRU on the main mounting bracket

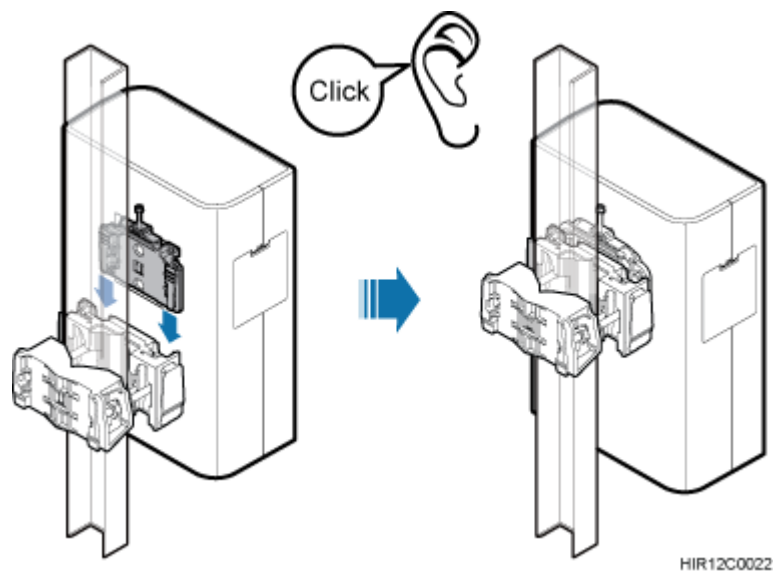
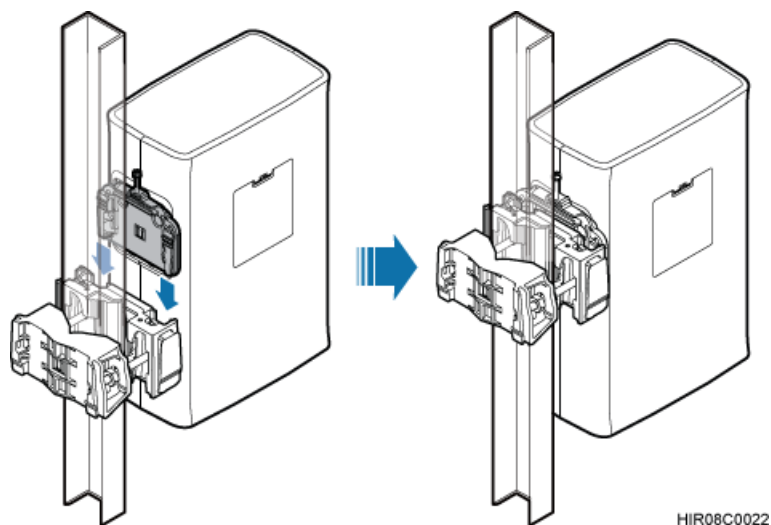

Figure 6-28 Installing the RRU on the main mounting bracket



---End

6.4 Installing the RRU on Angle Steel

This section describes the procedure for installing the RRU on angle steel and the precautions that must be taken during the installation. The RRU installed on angle steel can be mounted to a tower or placed on the ground. It is recommended that only one RRU be installed on angle steel.

Prerequisite

Before you install an RRU on a tower, the RRU and mounting kits are hoisted onto the tower. For details, see [6.6 Hoisting an RRU onto a Tower](#).

The hoist clamp on the main mounting bracket is secured properly.

Context

[Figure 6-29](#) shows the top view of the RRU installed on angle steel.

Figure 6-29 Top view of the RRU

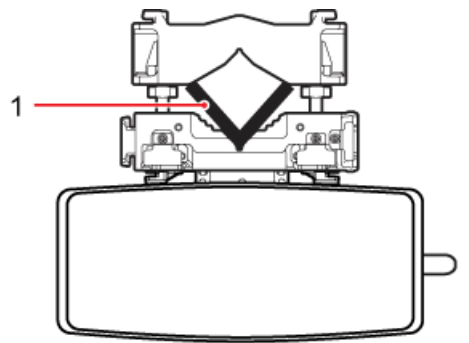

HIR06C0025

(1) Angle steel

Procedure

Step 1 Determine a position for installing the main mounting bracket.

- If the RRU must be installed on a tower, see [3.5.1 Installation Clearance for a Single RRU](#) to determine a position.
- If the RRU must be installed on the ground, see [Figure 6-30](#) to determine a position.

Figure 6-30 Distance between the main mounting bracket and the ground

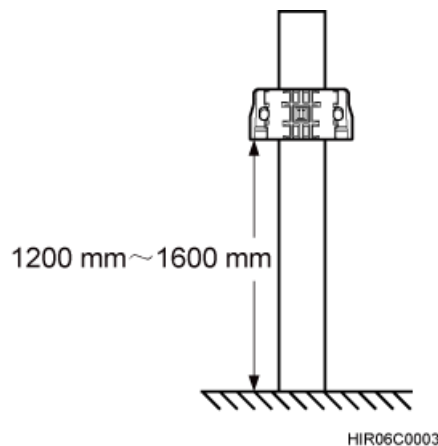

HIR06C0003

 **NOTE**

It is recommended that the main mounting bracket be 1,200 mm (47.24 in.) to 1,600 mm (62.99 in.) above the ground.

Step 2 Fit one end of the auxiliary mounting bracket to one dual-nut bolt assembly of the main mounting bracket.

Step 3 Install the bracket assembly on angle steel, and then fit the other end of the auxiliary mounting bracket to the other dual-nut bolt assembly, as shown in [Figure 6-31](#).

Figure 6-31 Installing the bracket assembly

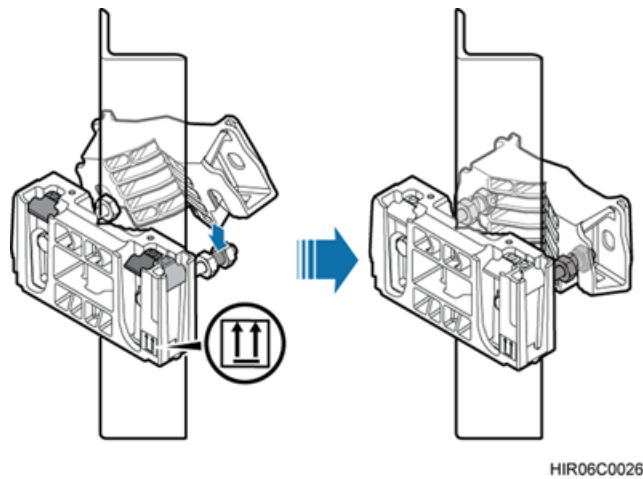

 **NOTE**

Verify that the arrow on the main mounting bracket is pointing up.

- Step 4** Using a torque wrench, tighten the nuts to 40 N·m (354.03 lbf·in.) to secure both the bracket assembly onto the angle steel, as shown in **Figure 6-32**.

 **CAUTION**

Tighten the two dual-nut bolt assemblies alternatively. After the main and auxiliary brackets are secured properly, measure the spacing between the brackets on both sides and ensure that the spacing is the same on the two sides.

Figure 6-32 Securing the bracket assembly onto angle steel

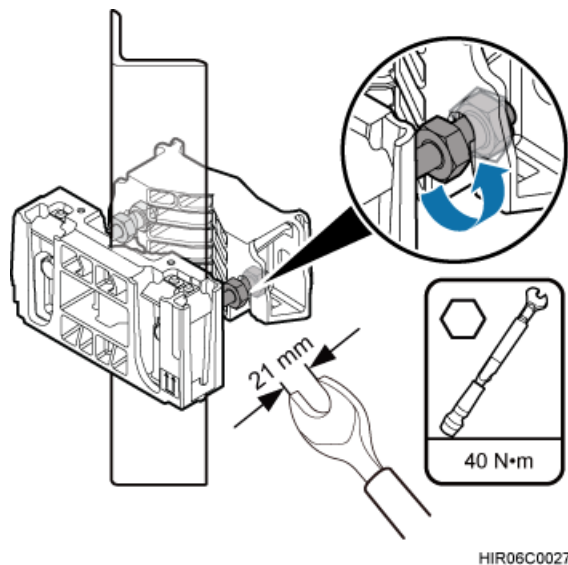
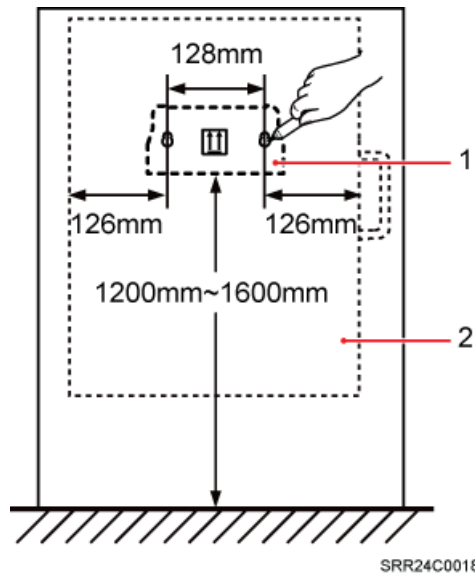

Figure 6-34 Marking anchor points



(1) Auxiliary mounting bracket

(2) RRU

NOTE

It is recommended that the auxiliary mounting bracket be 1,200 mm (47.24 in.) to 1,600 mm (62.99 in.) above the ground.

Figure 6-35 Expansion bolt assembly

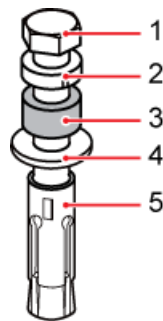

PIR06C0006

(1) M10x65 bolt

(2) Spring washer 10 (3) Plastic tube

(4) Flat washer 10 (5) Expansion tube

Step 2 Drill holes at the anchor points, and then insert expansion bolt assemblies, as shown in **Figure 6-36**.

Figure 6-36 Drilling a hole and inserting an expansion bolt assembly

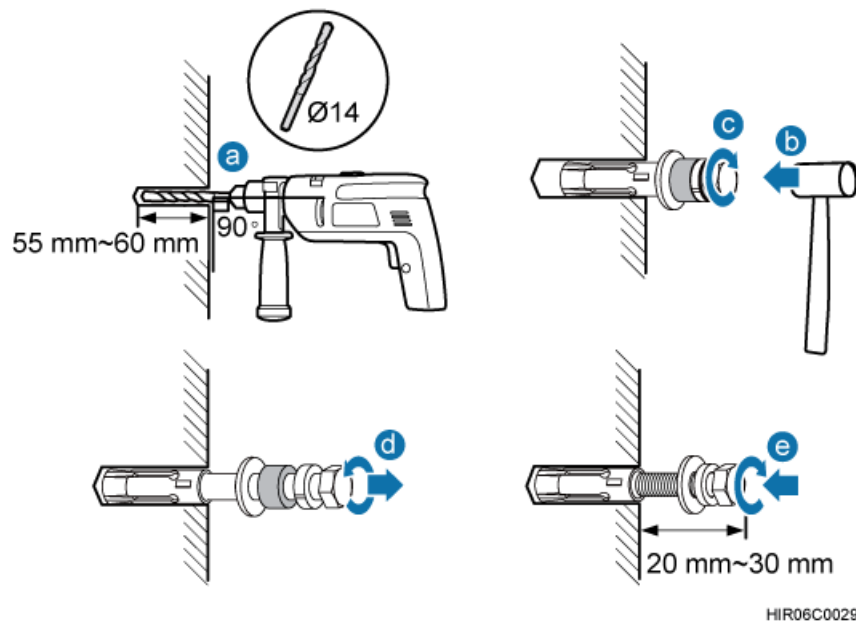

1. Use a hammer drill with a $\phi 14$ bit to drill holes vertically at the marked anchor points. Ensure that the depth of each hole ranges from 55 mm (2.17 in.) to 60 mm (2.36 in.).



WARNING

Take proper safety measures to protect your eyes and respiratory tract against the dust before drilling holes.

2. Hit the expansion bolt with a rubber mallet until the expansion tube completely enters the hole.
3. Tighten an expansion bolt slightly and place it vertically into each hole.
4. Remove the M10x65 bolt, spring washer, plastic tube, and flat washer from each expansion bolt assembly in sequence.



NOTE

After completely removing an expansion bolt, store the plastic tube properly.

5. Hammer the bolt into the wall.



CAUTION

Do not hammer the expansion bolt entirely into the wall. Instead, leave 20 mm (0.79 in.) to 30 mm (1.18 in.) of the expansion bolt outside the wall.

- Step 3** Fit the auxiliary mounting bracket on the expansion bolt, and then use a torque wrench (17 mm [0.67 in.]) to tighten the expansion bolt to 30 N·m (265.52 lbf·in.), as shown in [Figure 6-37](#).

Figure 6-37 Fitting the auxiliary mounting bracket on expansion bolts

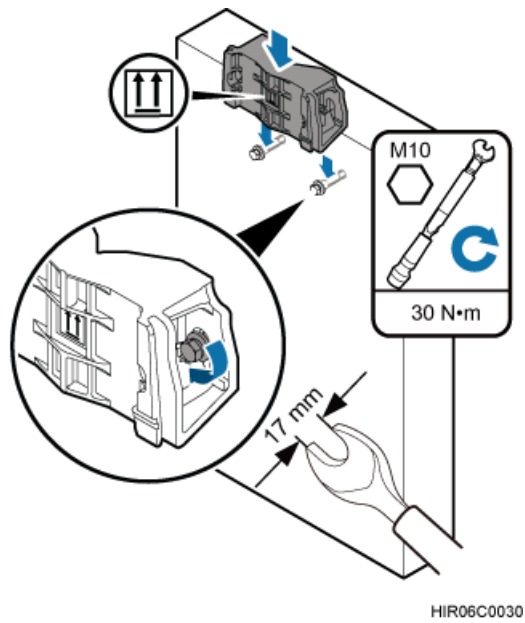

CAUTION

Verify that the arrow on the auxiliary mounting bracket is pointing up.

- Step 4** Loosen the screws on the main mounting bracket and store them properly.
- Step 5** Install the main mounting bracket, as shown in [Figure 6-38](#).

Figure 6-38 Installing the main mounting bracket

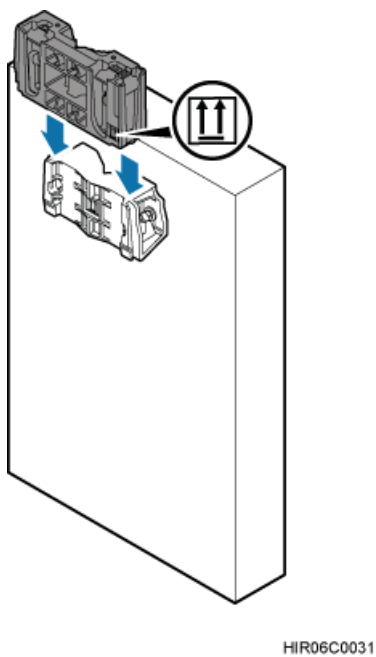

Step 6 Install the RRU on the main mounting bracket until the RRU snaps shut, as shown in **Figure 6-39**.

Figure 6-39 Installing the RRU

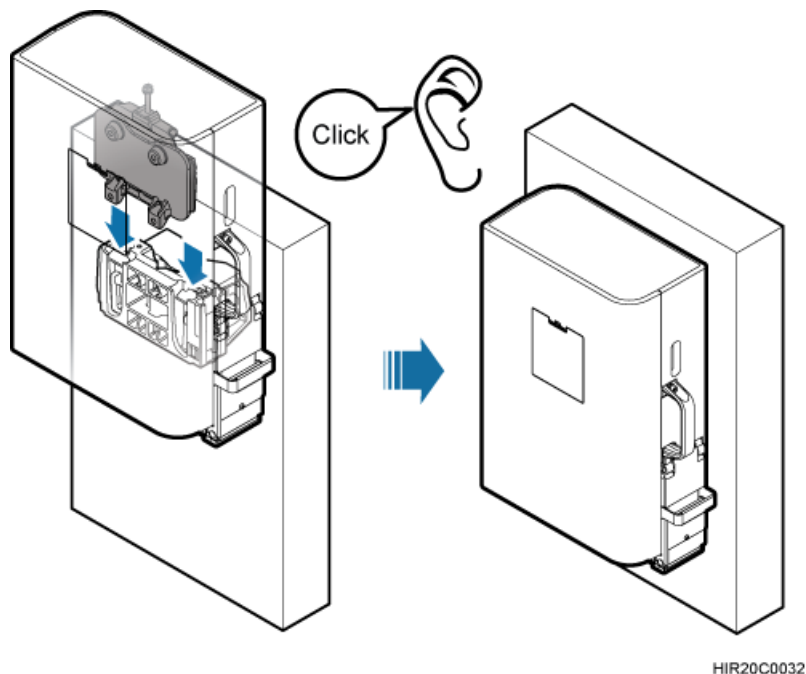

---End

6.6 Hoisting an RRU onto a Tower

Before installing an RRU on a tower, bind the RRU and mounting kits and then hoist them onto the tower. The RRU can be installed on a pole, U-steel, or angle steel. This section describes the procedure for hoisting the RRU and mounting kits onto the tower and the precautions that must be taken.

Prerequisite

Place a foam pad or cardboard on the ground to protect the housing of the RRU from damage before the binding. Do not stand the RRU upright because the load-bearing capacity of the RF ports at the RRU bottom is low.



CAUTION

When installed on a tower, only one RRU can be installed in standard mode or reverse mode, and two RRUs can be installed on a pole in back-to-back mode. RRUs cannot be installed on the side, and the brackets for more than two RRUs cannot be combined.

Procedure

Step 1 Bind the RRU and mounting kits properly using a lifting sling, as shown in [Figure 6-40](#).

Figure 6-40 Binding mounting kits for the RRU

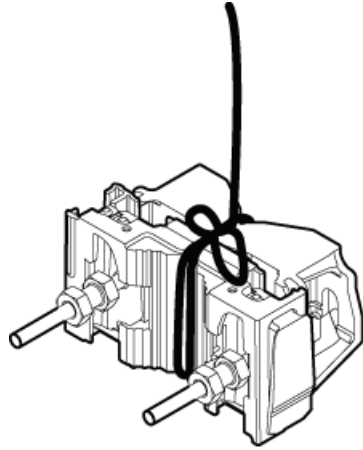

HIR06C0033

Step 2 Lead one sling through the lifting eye and RRU handle and use the sling as a lifting sling, and lead the other sling through the RRU handle and use the sling as a traction sling, as shown in [Figure 6-41](#).

Figure 6-41 Binding the RRU

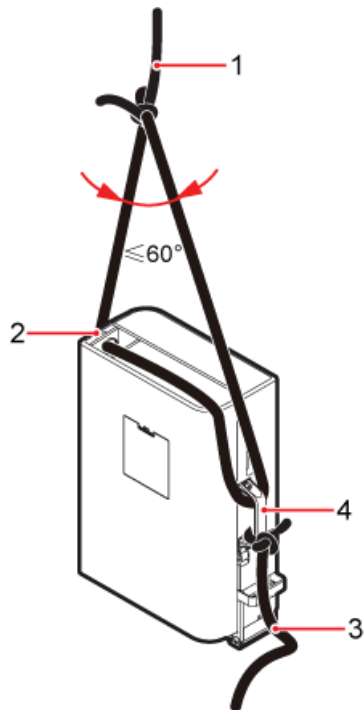

HIR20C0033

(1) Lifting sling

(2) Lifting eye

(3) Traction sling

(4) Handle

 **CAUTION**

- Each sling has a maximum load-bearing capacity of 200 kg (441 lb), the diameter of the sling must be less than 25 mm (0.98 in.), and the angle at the top of the traction sling [by the knot] must not be greater than 60 degrees.
 - When hoisting the RRU and mounting kits onto the tower, protect them from colliding with the ground and tower.
 - Hoist the RRU onto the tower before it is installed on a pole, angle steel, or U-steel.
 - Do not hoist the RRU by the handle or lifting eye only, as shown in [Figure 6-42](#) and [Figure 6-43](#).
-

Figure 6-42 Incorrect binding method

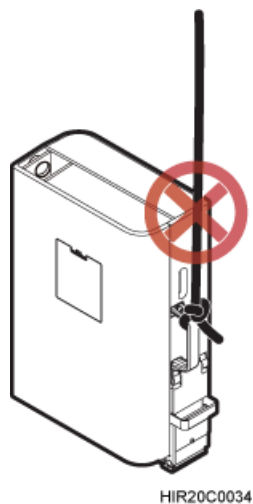
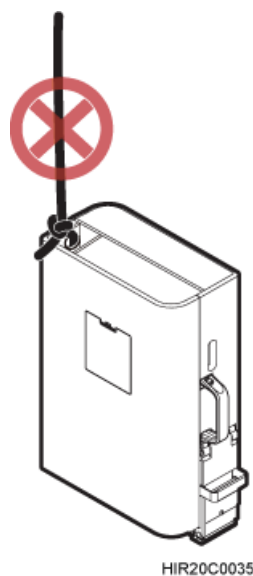

Figure 6-43 Incorrect binding method



Step 3 Hoist the RRU and mounting kits onto the tower respectively, as shown in [Figure 6-44](#).

 **NOTE**

Hoist mounting kits onto the tower and then install the mounting kits before hoisting the RRU onto the tower. When hoisting the mounting kits and RRU, protect them from colliding with the tower.

Figure 6-44 Hoisting the RRU onto the tower

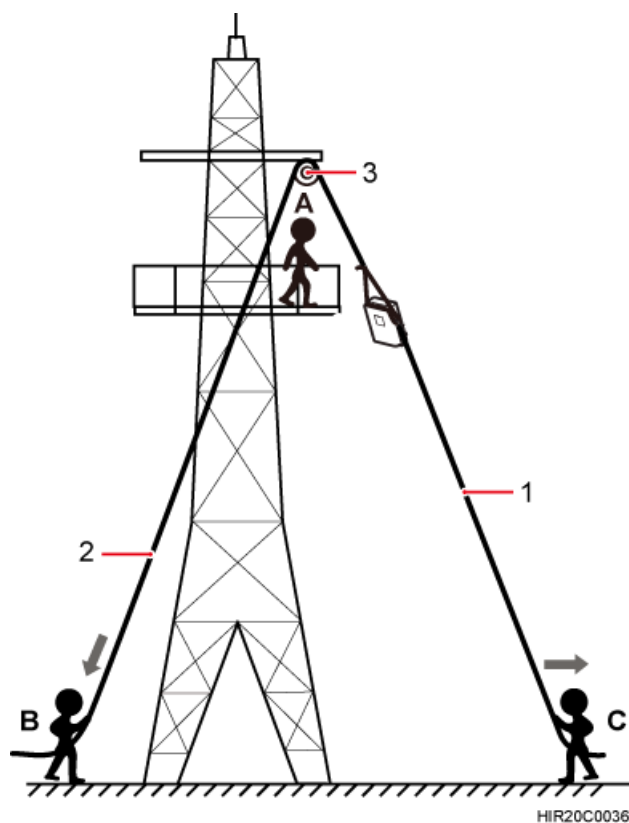

(1) Traction sling

(2) Lifting sling

(3) Fixed pulley

1. After climbing up to the tower, installation engineer A secures the fixed pulley to the tower platform support and leads the lifting sling through the fixed pulley.
2. Installation engineer C binds the RRU using the lifting sling and secures the traction sling to the RRU handle.
3. Installation engineer B pulls the lifting sling downwards, and installation engineer C pulls the traction sling outwards to protect the RRU and mounting kits from colliding with the tower.
4. Installation engineer A catches the RRU, install the RRU on the main mounting bracket until the RRU snaps shut, and then unties the sling.

 **NOTE**

The procedure for hoisting the RRU onto the tower is for your reference only.

----End

7 Installing RRU Cables

About This Chapter

This section describes the procedures for installing remote radio unit (RRU) cables.

[7.1 Cabling Requirements](#)

Cables must be routed according to the specified cabling requirements to prevent signal interference.

[7.2 Cable Connections](#)

This section describes the remote radio unit (RRU) cable connections.

[7.3 Installation Process](#)

This section describes the process of installing RRU cables.

[7.4 RRU Cable List](#)

This section provides a remote radio unit (RRU) cable list.

[7.5 Installing the RRU PGND Cable](#)

This section describes the procedure for installing a remote radio unit (RRU) protection ground (PGND) cable.

[7.6 Installing an RRU RF Jumper](#)

This section describes the procedure for installing an RRU RF jumper.

[7.7 Installing an Inter-RRU RF Cable](#)

This section describes the procedure for installing the inter-RRU RF cable.

[7.8 Installing an RRU AISG Multi-Wire Cable and AISG Extension Cable](#)

This section describes the procedures for installing an RRU AISG multi-wire cable and AISG extension cable.

[7.9 Opening the Cover Plate of an RRU Cabling Cavity](#)

This section describes the procedure for opening the cover plate of an RRU cabling cavity.

[7.10 Installing an RRU power cable](#)

This section describes the procedure for installing an RRU power cable.

[7.11 Installing a CPRI Fiber Optic Cable](#)

This section describes the procedure for installing a CPRI fiber optic cable.

[7.12 Installing an RRU Alarm Cable](#)

This section describes the procedure for installing an RRU alarm cable.

[7.13 Closing the Cover Plate of an RRU Cabling Cavity](#)

This section describes the procedure for closing the cover plate of an RRU cabling cavity.

7.1 Cabling Requirements

Cables must be routed according to the specified cabling requirements to prevent signal interference.

 **NOTE**

If a cable listed below is not required, skip the routing requirements of the cable.

General Cabling Requirements

Requirements for Bending Radius

- The bending radius of the 7/8" feeder must be more than 250 mm (9.84 in.), and the bending radius of the 5/4" feeder must be more than 380 mm (14.96 in.).
- The bending radius of the 1/4" jumper must be more than 35 mm (1.38 in.). The bending radius of the super-flexible 1/2" jumper must be more than 50 mm (1.97 in.), and the bending radius of the ordinary 1/2" jumper must be more than 127 mm (5 in.).
- The bending radius of the power cable or PGND cable must be at least three times the diameter of the cable.
- The bending radius of a fiber optic cable is at least 20 times the diameter of the fiber optic cable, and the minimum bending radius of the breakout cable at each end of the fiber optic cable is 30 mm (1.18 in.).
- The bending radius of the E1/T1 cable must be at least three times the diameter of the cable.
- The bending radius of the signal cable must be at least five times the diameter of the cable.

Requirements for Cable Binding

- The same types of cable must be bound together.
- Different types of cable must be separately routed with the minimum spacing of 30 mm (1.18 in.) and cannot be entangled.
- The cables must be bound tightly and neatly. The sheaths of the cables must not be damaged.
- Cable ties are installed in the same direction, and those at the same horizontal line must be in a straight line.
- The excess of indoor cable ties is trimmed off, and the excess of outdoor cable ties allows about 5 mm (0.2 in.), without remaining rough edges.
- Labels or nameplates must be attached to both ends, joints, or turns of cables after they are installed.

Security Requirements

- Cables should be placed away from sharp objects or wall burrs. If these positions are inevitable, protect the cables with protection pipes.
- Cables must be routed away from heat sources, or heat-insulation materials are added between cables and heat sources.
- Sufficient slack (recommended for about 0.1 m [0.33 ft.]) is provided in cables at turns or the position close to a device, facilitating cable and device maintenance.

Indoor Cabling Requirements

- Cables are routed indoors through the feeder window.
- Drip loops must be made outside the feeder window, and the requirements for the minimum bending radius are met.

- When cables are routed indoors, engineers are required indoors for cooperation.
- The feeder window must be waterproofed.

Outdoor Cabling Requirements

- Cables routed outdoors must be led through a pipe when they may be damaged.
- AC power cables, transmission cables, and cables buried in the ground must be protected.
- If cables at the cabinet bottom need to be routed through a pipe along the ground, lead the pipe into the cabinet base for about 3 m (9.84 ft.) to 5 m (16.4 ft.), not into the cabinet. Block the pipe with waterproof tape or silicon gel, and secure the pipe to the cable hole at the cabinet bottom with metal piece.
- If cables at the cabinet bottom need to be routed through a pipe along the metal cable trough, do not lead the pipe into the cabinet base. The cable trough must be sealed and routed through the cable hole at the cabinet bottom.
- Cables are secured with cable clips.
- Cables are routed neatly along the specified cabling direction and secured with cable clips.
- The positions for cable clips are determined onsite. For example, the cable clips for the 7/8" feeder are installed at the spacing of 1.5 m (4.92 ft.) to 2 m (6.56 ft.) in the same direction, and the cable clips for the power cables are installed at the spacing of 1 m (3.28 ft.) to 1.5 m (4.92 ft.) in the same direction.
- Cable clips must be vertical with cables, and the cables in a cable clip must be parallel.
- After routing cables neatly and correctly, tighten the screws on cable clips.

Secure cables on the cable tray, as shown in [Figure 7-1](#).

Figure 7-1 Securing cables on the cable tray

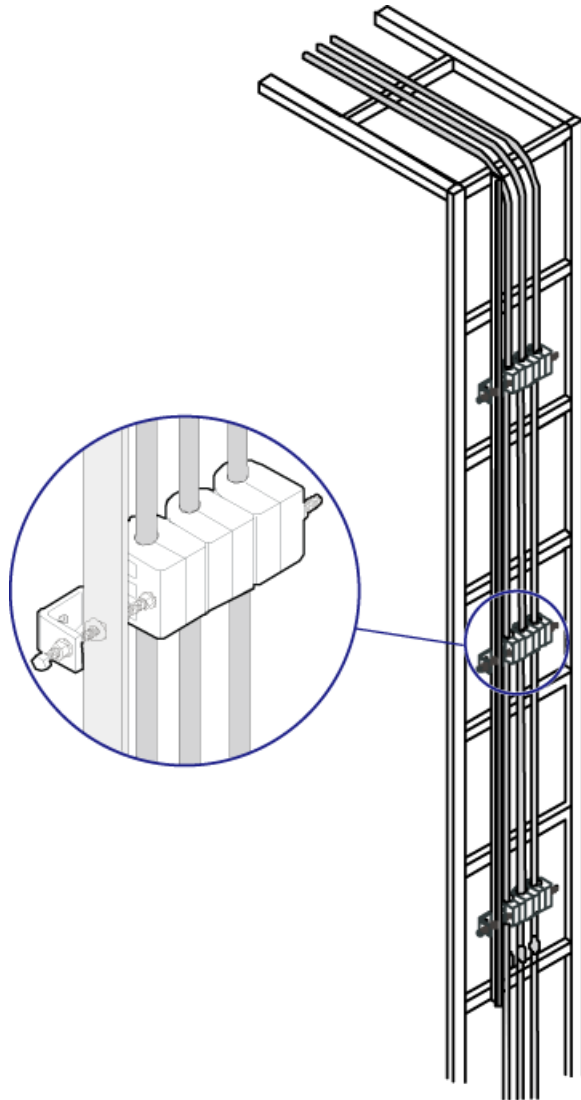

Secure cables on the tower, as shown in **Figure 7-2**.

Figure 7-2 Securing cables on the tower

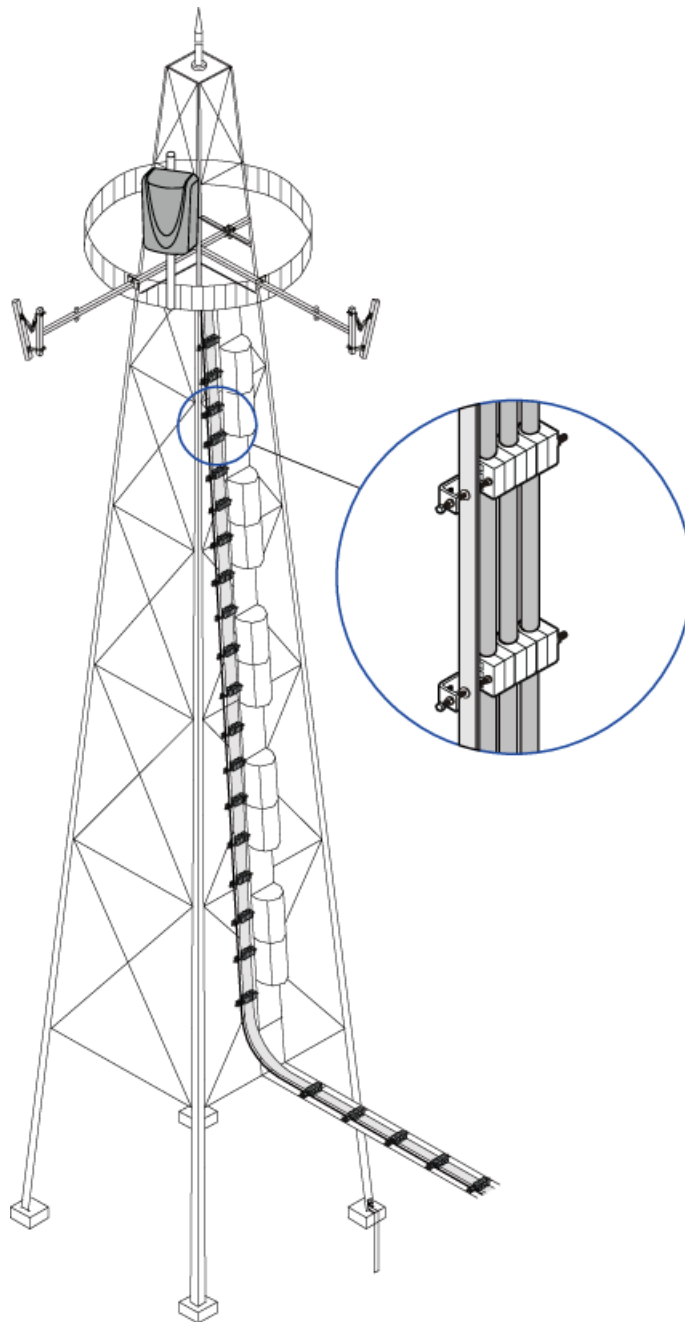

Special Cabling Requirements

Cabling Requirements for Power Cables

- Power cables must be installed in the position specified in engineering design documents.
- If the length of power cables is insufficient, replace the cables rather than adding connectors or soldering joints to lengthen the cables.
- Cables must be routed by only qualified and trained personnel before all preparations are made.

- Cables are routed in an untangled and orderly fashion.
- If DC power cables need to be routed on the tower platform, lay out the cables on the guardrail with the shortest distance and route the cables along the guardrail.
- If DC power cables need to be routed close to a device on the tower, secure the cables to the guardrail or pole with cable clips. The device cannot be far away from the position for securing the cables.

Cabling Requirements for PGND Cables

- PGND cables for the base station must be connected to the same ground bar.
- PGND cables must be buried in the ground or routed indoors. They should not be routed overhead before they are led into the equipment room.
- The exterior of the coaxial wire and the shield layer of the shielded cable must have proper electrical contact with the metal surface of the equipment to which they are connected.
- PGND cables and signal cables must be installed in an untangled and orderly fashion. A certain distance must be reserved between them to prevent interference from each other.
- Fuses or switches must not be installed on the PGND cables.
- Other devices must not be used for electrical connections of the PGND cables.
- All the metal parts in the housing of the equipment must be reliably connected to the ground terminal.

Cabling Requirements for E1 Cables

- E1 cables must not cross power cables, PGND cables, or RF cables when routed. If transmission cables are routed with power cables, PGND cables, or RF cables in parallel, the spacing between them must be greater than 30 mm (1.18 in.).
- E1 cables are routed straightly and bound neatly with cable ties.
- Sufficient slack is provided in E1 cables at turns.

Cabling Requirements for Fiber Optic Cables

- Fiber optic cables must be routed by at least three qualified and trained personnel before all preparations are made.
- Fiber optic cables are used within the temperature range of -40°C to 60°C. If the current temperature is out of the range, make protection measures or route the cables again.
- Cables are routed in an untangled and orderly fashion.
- Do not bind fiber optic cables at turns.
- Do not stretch, step on, or place heavy objects on fiber optic cables. Keep the cables away from sharp objects.
- When fiber optic cables are routed, the excess of the cables must be coiled around special devices, such as a fiber coiler.
- When coiling fiber optic cables, apply even strength. Do not bend the cables with force.
- Vacant optical connectors must be covered with dustproof caps.
- Fiber optic cables cannot be squeezed by the cabinet door when routed through the cabinet.
- If fiber optic cables need to be routed on the tower platform, lay out the cables on the guardrail with the shortest distance and route the cables along the guardrail.
- If fiber optic cables need to be routed close to a device on the tower, secure the cables to the guardrail or pole with cable clips. The device cannot be far away from the position for securing the cables.

- If the fiber optic cables close to a device are too long, coil the excess of the cables and secure them on the tower.

7.2 Cable Connections

This section describes the remote radio unit (RRU) cable connections.

 **NOTE**

RRU power cables cannot be cascaded.

Figure 7-3 shows the cable connections of a single RRU in a base station in CDMA only (CO) mode. CDMA is short for Code Division Multiple Access.

Figure 7-3 Cable connections of a single RRU in a base station in CO mode

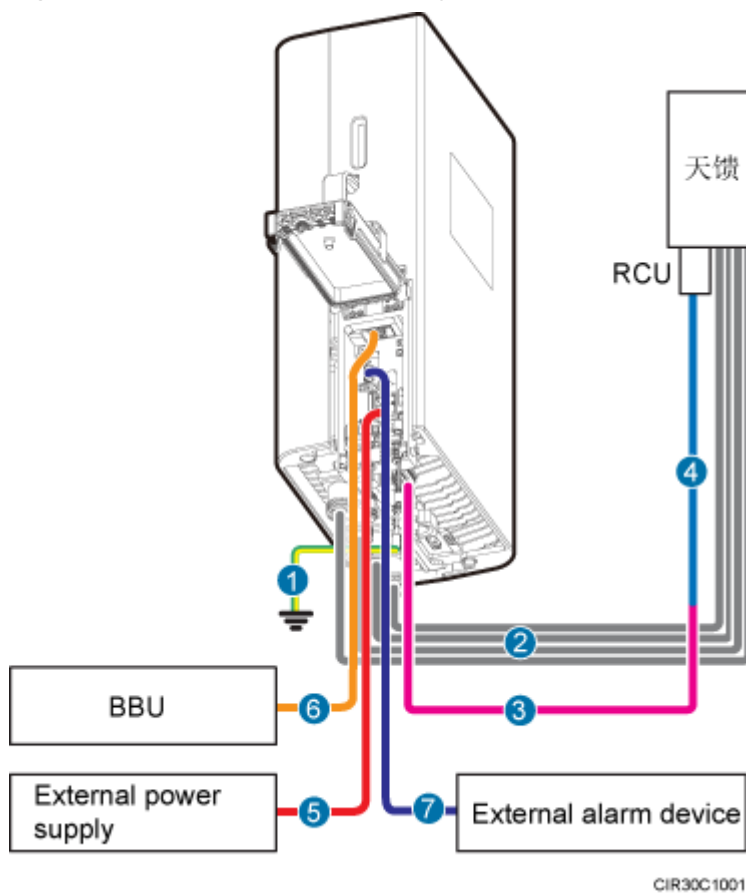

- | | | |
|-------------------------------------|--------------------------------|--|
| 1. Protection ground (PGND) cable | 2. Radio frequency (RF) jumper | 3. Antenna Interface Standards Group (AISG) multi-wire cable for the RRU |
| 4. AISG extension cable for the RRU | 5. RRU power cable | 6. Common public radio interface (CPRI) optical fiber |
| 7. RRU alarm cable | - | - |

Figure 7-4 shows the cable connections of a single RRU in a base station in CDMA+UMTS (CU) or CDMA+LTE (CL) mode. UMTS is short for Universal Mobile Telecommunications System. LTE is short for Long Term Evolution.

Figure 7-4 Cable connections of a single RRU in a base station in CU or CL mode

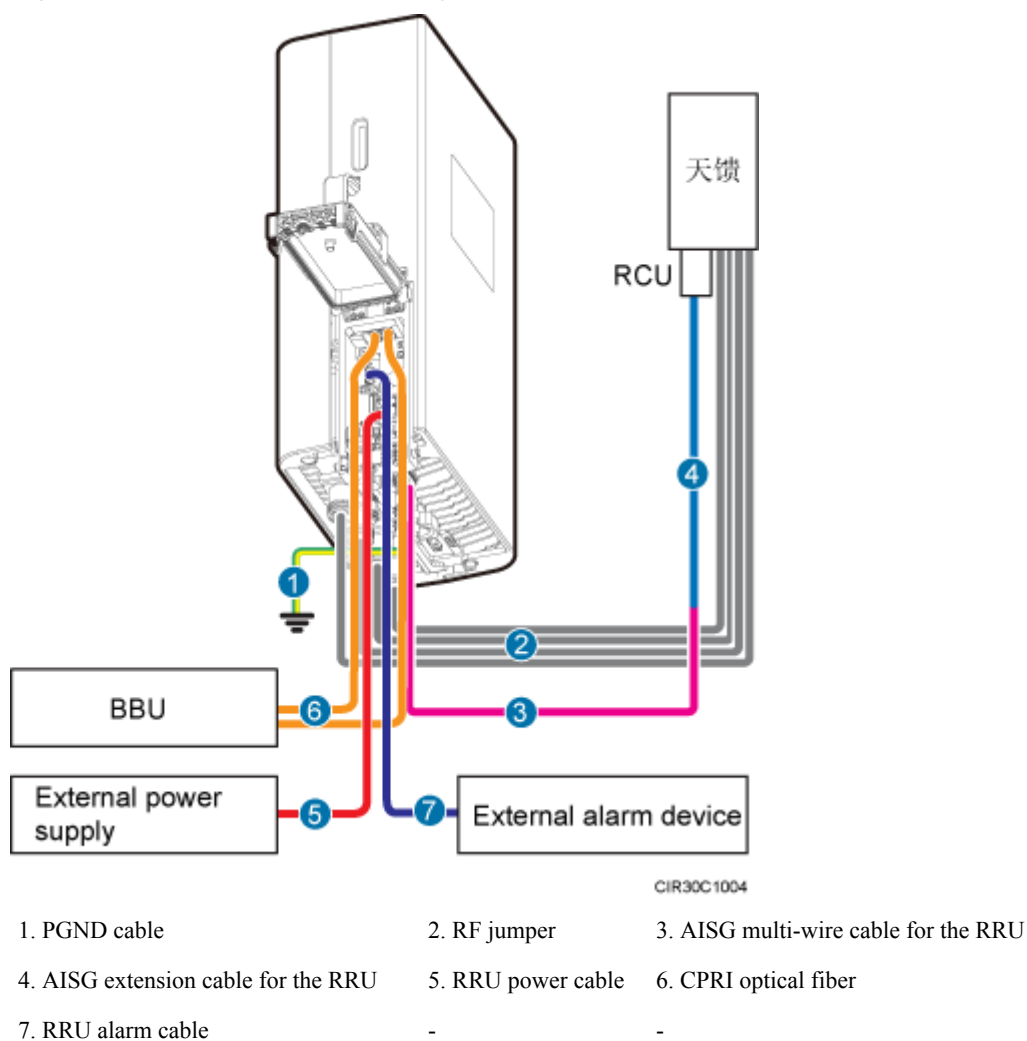
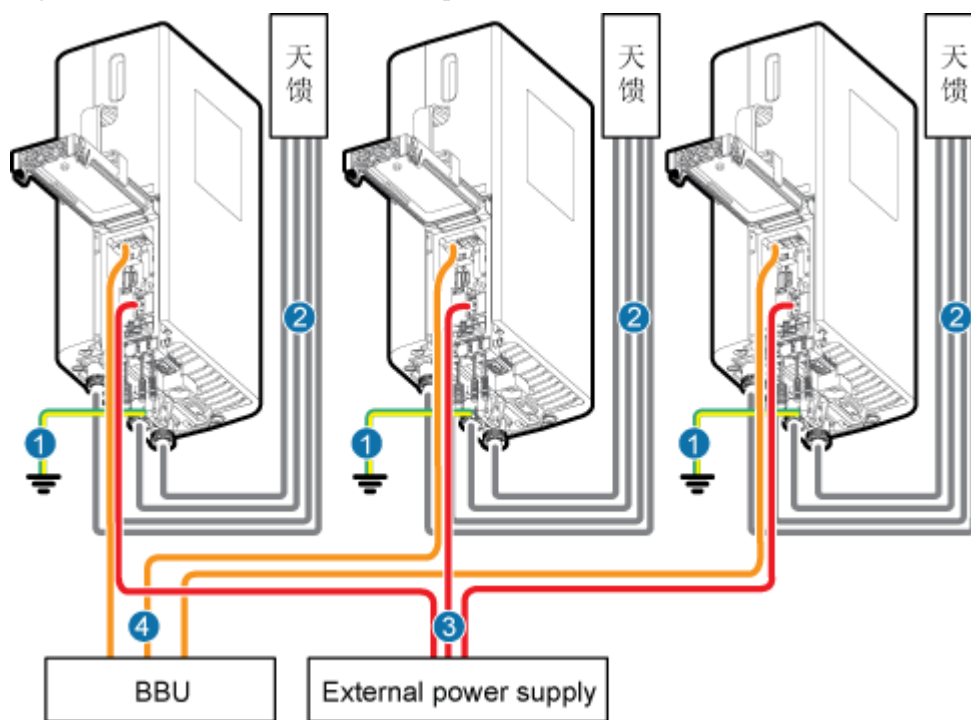

Figure 7-5 shows the cable connections of multiple RRUs in a base station in CO mode.

Figure 7-5 Cable connections of multiple RRUs in a base station in CO mode



CIR30C1002

- | | | |
|-----------------------|--------------|--------------------|
| 1. PGND cable | 2. RF jumper | 3. RRU power cable |
| 4. CPRI optical fiber | - | - |

Figure 7-6 shows the cable connections of multiple RRUs in a base station in CU or CL mode.

Figure 7-6 Cable connections of multiple RRUs in a base station in CU or CL mode

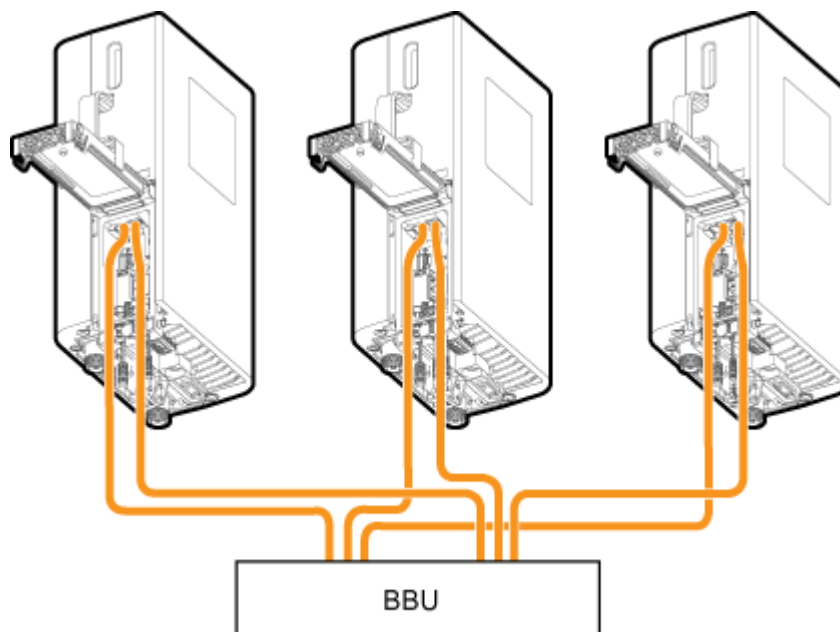

CIR30C1005

7.3 Installation Process

This section describes the process of installing RRU cables.

Figure 7-7 shows the process of installing RRU cables.

Figure 7-7 Process of installing RRU cables

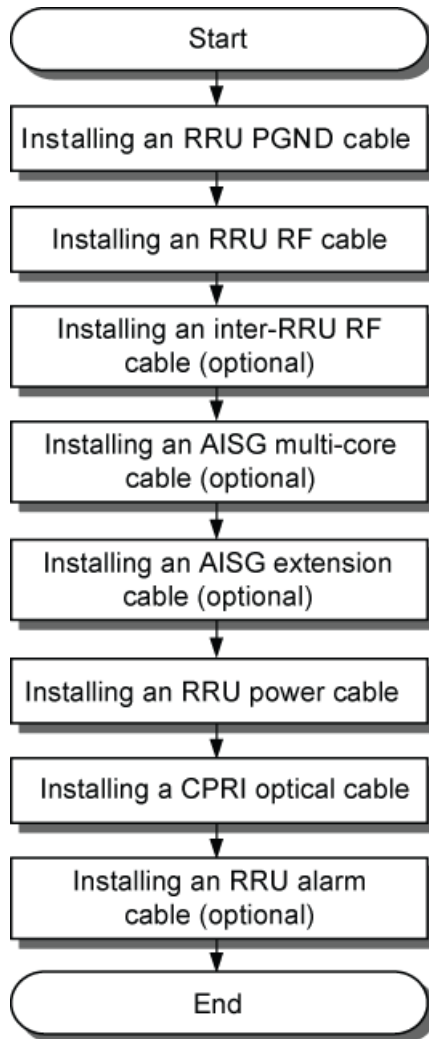

IPR14C0002

7.4 RRU Cable List

This section provides a remote radio unit (RRU) cable list.

Table 7-1 lists RRU cables.

Table 7-1 RRU cable list

Cable	One End		The Other End	
	Connector	Installation Position	Connector	Installation Position
RRU PGND Cable	M6 OT terminal with a cross-sectional area of 16 mm ² (0.02 in. ² or 6 AWG)	Ground terminal on the RRU	M8 OT terminal with a cross-sectional area of 16 mm ² (0.02 in. ² or 6 AWG)	Ground terminal on the ground bar
RRU power cable	Easy power receptacle (pressfit type) connector	NEG(-) and RTN(+) ports on the RRU	Easy power receptacle (pressfit type) connector	One of six ports (RRU0-RRU5) on the embedded power subrack unit (EPU) One of six ports (LOAD0-LOAD5) on the direct current distribution unit-11B (DCDU-11B)
RRU alarm cable	DB15 connector	EXT_ALM port on the RRU	Cord end terminal	External alarm device

Cable	One End		The Other End	
	Connector	Installation Position	Connector	Installation Position
Multi-mode common public radio interface (CPRI) optical fiber	DLC connector	CPRI0 port on the RRU CPRI1 port on the RRU	DLC connector	Code Division Multiple Access (CDMA) +Universal Mobile Telecommunications System (UMTS) mode SFP port on the HCPM or HECM in the baseband unit (BBU) CPRI port on the WBBP in the BBU CDMA+Long Term Evolution (LTE) mode SFP port on the Huawei Enhanced Radio Terminal (HERT) channel processing module (HCPM) or HERT enhance channel processing (HECM) in the BBU CPRI port on the LTE baseband processing unit (LBBP) in the BBU
Single-mode CPRI optical fiber	DLC connector	CPRI0 port on the RRU	DLC connector	CDMA only (CO) mode SFP port on the HCPM or HECM in the BBU

Cable	One End		The Other End	
	Connector	Installation Position	Connector	Installation Position
RRU radio frequency (RF) jumper	DIN male connector	ANT_TX/RXA or ANT_TX/RXB port on the RRU	DIN male connector	Antenna system
Inter-RRU RF cable	DB2W2 connector	RX_IN/OUT port on the RRU	DB2W2 connector	RX_IN/OUT port on the RRU
AISG multi-wire cable for the RRU	Waterproof DB9 male connector	RET port on the RRU	Standard AISG female connector	Standard AISG male connector on the remote control unit (RCU) or on the AISG extension cable
RRU AISG extension cable	Standard AISG male connector	Standard AISG female connector on the AISG multi-wire cable	Standard AISG female connector	Standard AISG male connector on the RCU

7.5 Installing the RRU PGND Cable

This section describes the procedure for installing a remote radio unit (RRU) protection ground (PGND) cable.

Context

The cross-sectional area of the RRU3642 PGND cable is 16 mm² (0.02 in.² or 6 AWG). One end of the cable is terminated with an M6 OT terminal, and other end is terminated with an M8 OT terminal.

Procedure

Step 1 Prepare an RRU PGND cable.

1. Cut off the extra length of a PGND cable based on the required cable route.
2. Install an OT terminal on each end of the cable by referring to Assembling the OT Terminal and the Power Cable.

Step 2 Install the RRU PGND cable.

Connect the M6 OT terminal at one end of the PGND cable to the ground terminal at the bottom of the RRU, and connect the M8 OT terminal at the other end of the PGND cable to the external ground bar, as shown in [Figure 7-8](#).

Figure 7-8 Installing the RRU PGND cable

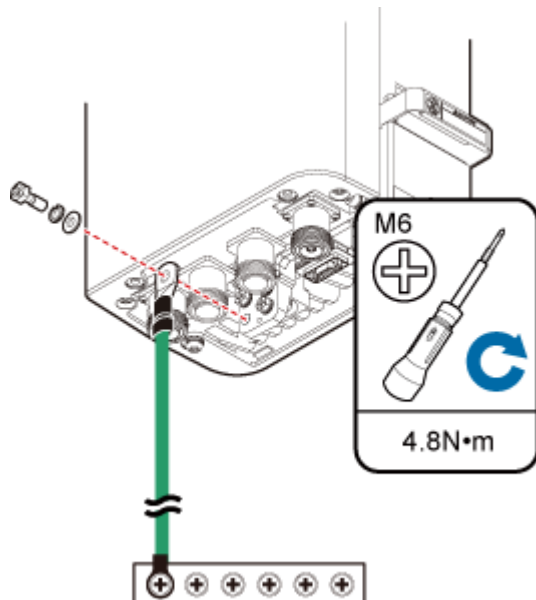

NOTE

You must correctly crimp the OT terminals in the direction shown in [Figure 7-9](#).

Figure 7-9 Direction for crimping OT terminals

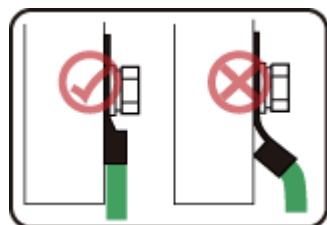

Step 3 Label the installed cable by referring to Attaching a Cable-Tying Label.

---End

7.6 Installing an RRU RF Jumper

This section describes the procedure for installing an RRU RF jumper.

Procedure

Step 1 Link the DIN connector at one end of the RF jumper to the ANT port and use a torque wrench to tighten the connector to 25 N·m (221.27 lbf-in.), as shown in [Figure 7-10](#).

Figure 7-10 Installing an RRU RF jumper

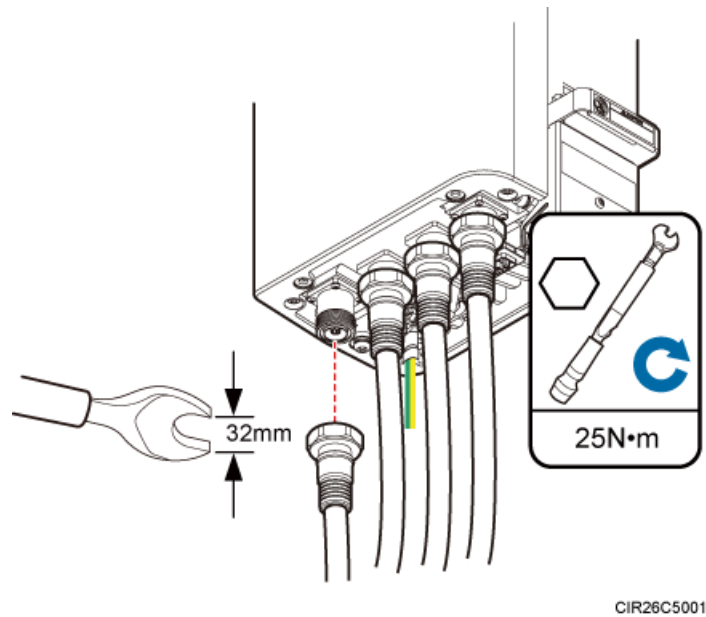

 **CAUTION**

On AC-powered electric railways, such as high speed railways, when leaky cables are connected to RRUs installed in tunnels, high-voltage-resistance DC blocks must be installed between RRU RF jumpers and the leaky cables to protect the RRUs against damage.

- Step 2** Link the other end of the RF jumper to the external antenna system.
- Step 3** Waterproof the connectors of the RF jumper by referring to [Figure 7-11](#).

Figure 7-11 Waterproofing a connector of the RF jumper

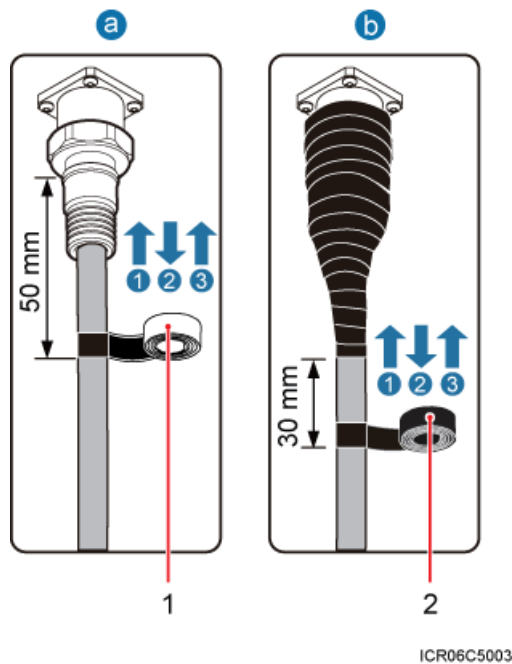

(1) Waterproof tape	(2) PVC insulation tape
---------------------	-------------------------

NOTE

- Before wrapping waterproof tape, stretch the tape evenly until the width of the tape is half of its original width.
 - Wrap each layer of tape around the connector tightly and neatly, and ensure that each layer of tape overlaps more than 50% of the preceding layer.
1. Wrap each connector with three layers of waterproof tape, from bottom up, then from top down, and finally from bottom up. Start the wrapping at the position 50 mm (1.97 in.) away from the bottom of the connector. Do not cut the tape until all the three layers of the tape are already wrapped. Wrap each layer of tape around the connector tightly.
 2. Wrap each connector with three layers of PVC insulation tape, from bottom up, then from top down, and finally from bottom up. Start the wrapping at the position 30 mm (1.18 in.) away from the bottom of the connector. Do not cut the tape until all the three layers of the tape are already wrapped. Wrap each layer of tape around the connector tightly.

Step 4 Check the dustproof caps on antenna connectors. In outdoor scenarios, dustproof caps must be waterproofed, as shown in [Figure 7-12](#).



Do not remove dustproof caps from vacant antenna connectors.

Figure 7-12 Waterproofing a dustproof cap

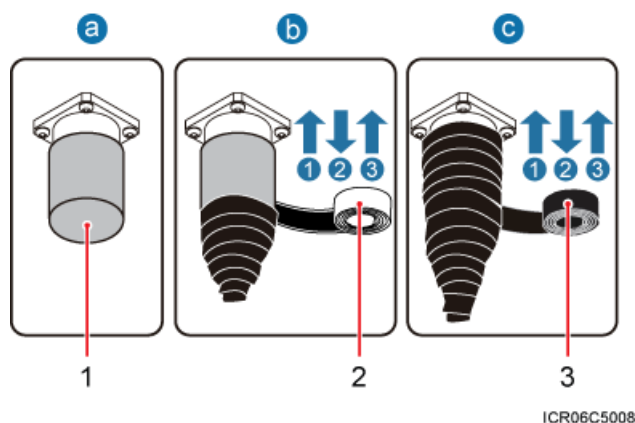

(1) Dustproof cap

(2) Waterproof tape

(3) PVC insulation tape

NOTE

- Before wrapping waterproof tape, stretch the tape evenly until the width of the tape is half of its original width.
- Wrap each layer of tape around the connector tightly and neatly, and ensure that each layer of tape overlaps more than 50% of the preceding layer.

1. Verify that dustproof caps are not removed.
2. Wrap each dustproof cap with three layers of waterproof tape, from bottom up, then from top down, and finally from bottom up. Do not cut the tape until all the three layers of the tape are already wrapped. Wrap each layer of tape around the cap tightly.
3. Wrap each dustproof cap with three layers of PVC insulation tape, from bottom up, then from top down, and finally from bottom up. Do not cut the tape until all the three layers of the tape are already wrapped. Wrap each layer of tape around the connector tightly.

Step 5 Lay out the jumper by referring to [7.1 Cabling Requirements](#), and then bind the jumper using cable ties.

Step 6 Label the installed jumper by referring to Attaching a Sign Plate Label.

Step 7 Attach colored insulation tapes to the jumper by referring to Attaching the Color Ring.

----End

7.7 Installing an Inter-RRU RF Cable

This section describes the procedure for installing the inter-RRU RF cable.

Procedure

Step 1 Link the DB2W2 connector at one end of the RF cable to the RX_IN/OUT port of an RRU, and link the other end to the RX_IN/OUT port of the other RRU, as shown in [Figure 7-13](#).

Figure 7-13 Installing an inter-RRU RF cable

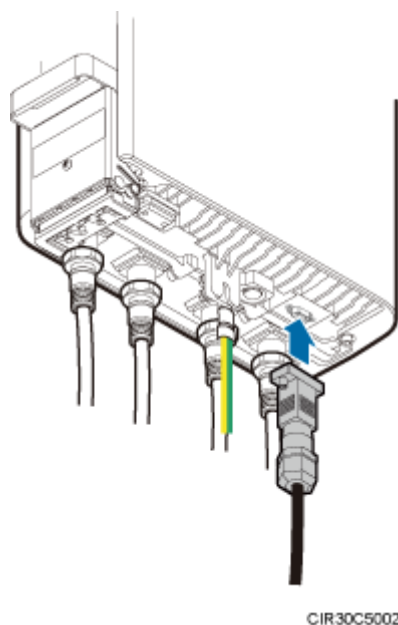

Step 2 Lay out the cable by referring to [7.1 Cabling Requirements](#), and then bind the cable using cable ties.

Step 3 Label the installed cable by referring to Attaching an L-Shaped Label.

---End

7.8 Installing an RRU AISG Multi-Wire Cable and AISG Extension Cable

This section describes the procedures for installing an RRU AISG multi-wire cable and AISG extension cable.

Context

When the distance between an RRU and a Remote Control Unit (RCU) is longer than 5 m (16.4 ft.), an AISG multi-wire cable is not long enough to connect the RRU and the RCU. In this case, an AISG extension cable is used to extend the AISG multi-wire cable.

Procedure

- Install an AISG multi-wire cable that is not configured with an AISG extension cable.
 1. Link the waterproofed DB9 connector at one end the AISG multi-wire cable to the RET port on the RRU bottom, as shown in [Figure 7-14](#).

Figure 7-14 Installing an RRU AISG multi-wire cable

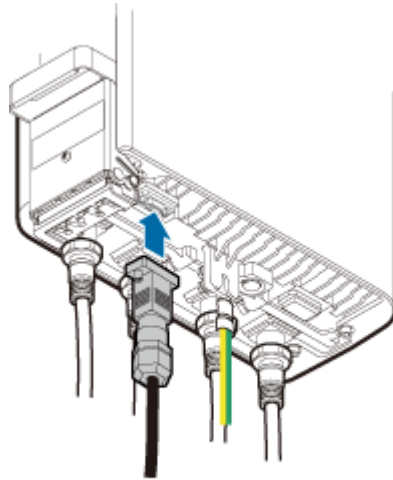

CIR30C5003

2. Connect the other end of the cable to the standard AISG male connector on the RCU.
 3. Lay out the cable by referring to [7.1 Cabling Requirements](#), and then bind the cable using cable ties.
 4. Label the installed cable by referring to Attaching an L-Shaped Label.
- Install an AISG multi-wire cable that is configured with an AISG extension cable.
 1. Link the waterproofed DB9 connector at one end of the AISG multi-wire cable to the RET port on the RRU bottom, and link the other end to the standard AISG male connector of the AISG extension cable, as shown in [Figure 7-15](#).

Figure 7-15 Installing an RRU AISG multi-wire cable

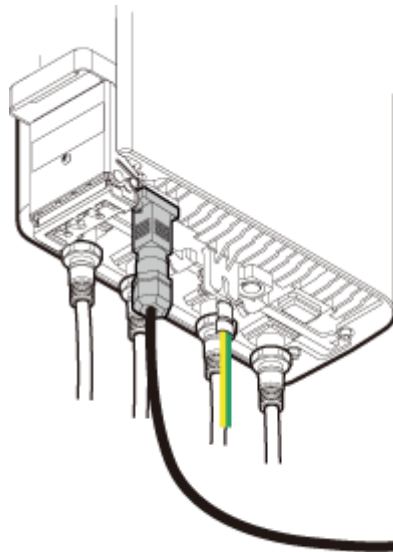

CIR30C5006

2. Connect the other end of the AISG extension cable to the standard AISG male connector on the RCU, as shown in [Figure 7-16](#).

Figure 7-16 Installing an RRU AISG multi-wire cable

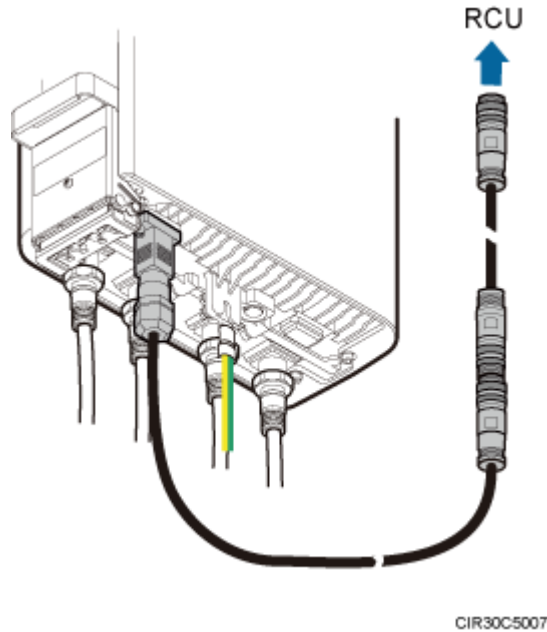

3. Lay out the cable by referring to [7.1 Cabling Requirements](#), and then bind the cable using cable ties.
4. Label the installed cable by referring to Attaching an L-Shaped Label.

---End

7.9 Opening the Cover Plate of an RRU Cabling Cavity

This section describes the procedure for opening the cover plate of an RRU cabling cavity.

Procedure

- Step 1** Wear ESD gloves.



CAUTION

Take proper ESD protection measures, for example, wear ESD gloves, to prevent electrostatic damage to the boards, modules, or electronic components.

- Step 2** Loosen the protection screw on the cover plate of the RRU cabling cavity using an M4 Phillips screwdriver, and then lower the handle to open the cover plate, as shown in [Figure 7-17](#).

Figure 7-17 Opening the cover plate of the RRU cabling cavity

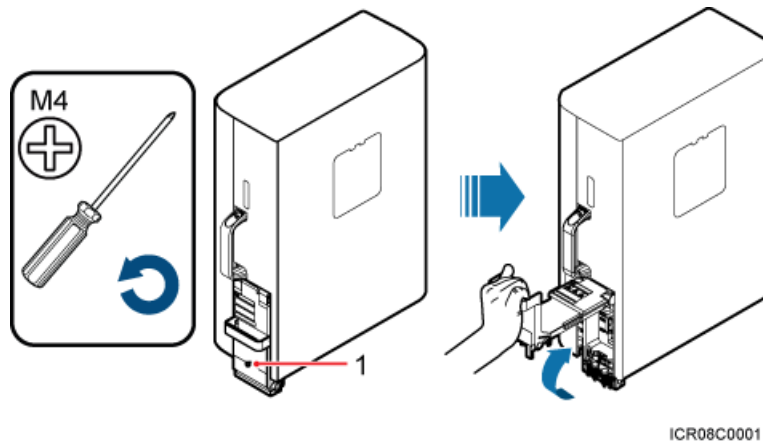

(1) Protection screw

Figure 7-18 shows the RRU cabling cavity.

Figure 7-18 RRU cabling cavity

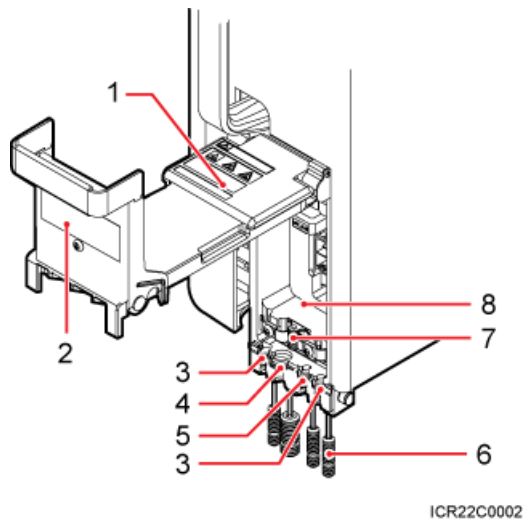

(1) Cover plate

(2) Cable diagram on labels

(3) Cable trough for the fiber optic cable

(4) Cable trough for the power cable

(5) Cable trough for the alarm cable (6) Waterproof block

(7) Clip

(8) Cabling cavity

-

Step 3 Loosen the screws on the clip, and open the clip, as shown **Figure 7-19**.

NOTE

Open the clip only for the associated cable.

Figure 7-19 Opening clips

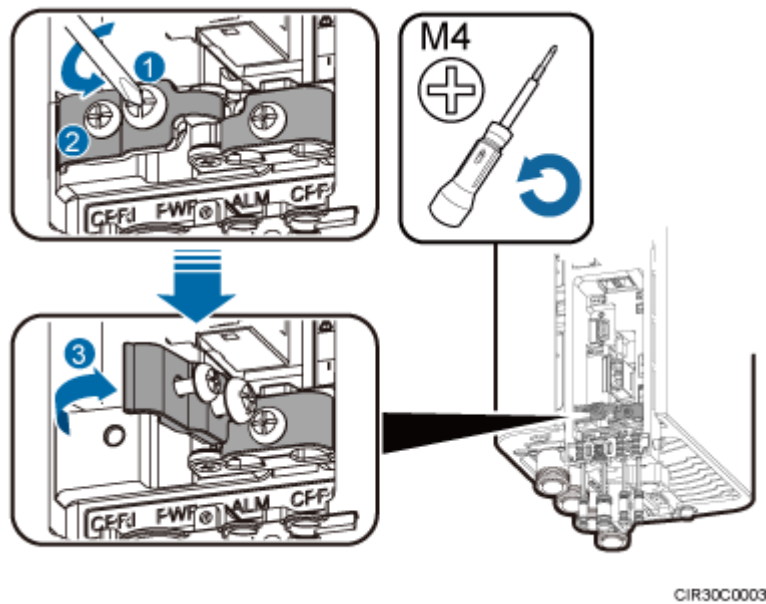

---End

7.10 Installing an RRU power cable

This section describes the procedure for installing an RRU power cable.

Prerequisite

- An easy power receptacle (pressfit type) connector is added to the RRU power cable on the RRU side. For details, see [10.1 Adding an Easy Power Receptacle \(Pressfit Type\) Connector to the RRU Power Cable on the RRU Side](#).
- A connector or OT terminals are added to the RRU power cable on the power device side. For details, see the *DBS3900 Installation Guide*.

Context

The cross-sectional area of the RRU power cable is 6 mm² (0.009 in.²).

Procedure

- Install an RRU power cable that feeds power to an RRU from a DCDU-11B when the DCDU-11B is configured.
 1. Link the easy power receptacle (pressfit type) connector at one end of the RRU power cable to the power supply socket on the RRU, as shown in [Figure 7-20](#).

Figure 7-20 Installing an RRU power cable

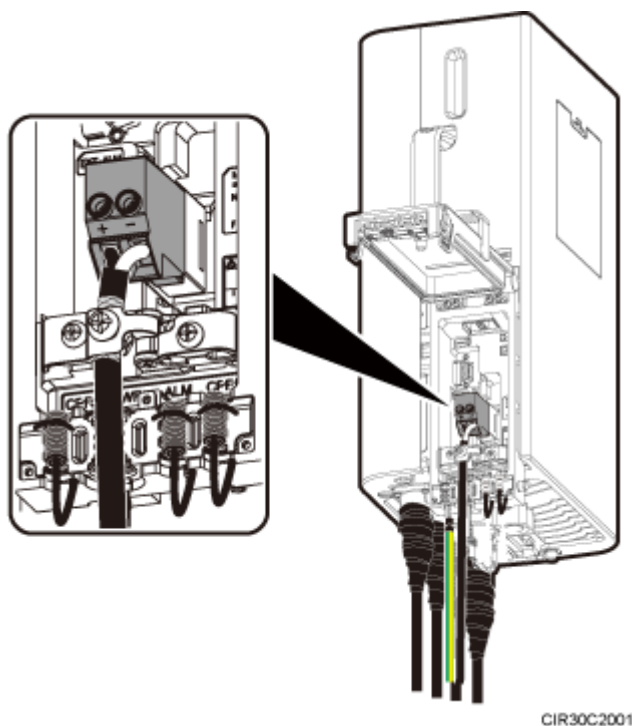

 **CAUTION**

Ensure that the exposed shield layer of the power cable is properly tightened using the clip.

-
2. Link the easy power receptacle (pressfit type) connector at the other end of the RRU power cable to the LOAD0 port on the DCDU-11B.

 **NOTE**

One DCDU-11B can supply power to a maximum of six RRUs. The RRU power cable can be connected to any wiring terminal from LOAD0 to LOAD5 on the DCDU-11B.

3. Lay out the cable by referring to [7.1 Cabling Requirements](#), and then bind the cable using cable ties.
 4. Label the installed cable by referring to Attaching a Cable-Tying Label.
- Install an RRU power cable that feeds power to an RRU from an EPU when the EPU is configured.
 1. Link the easy power receptacle (pressfit type) connector at one end of the RRU power cable to the power supply socket on the RRU, as shown in [Figure 7-20](#).
 2. Link the easy power receptacle (pressfit type) connector at one end of the RRU power cable to the RRU0 port on the EPU subrack.

 **NOTE**

- The blue core wire in the easy power receptacle (pressfit type) connector is linked to the left port on the EPU subrack, and the black/brown core wire is linked to the right port on the EPU subrack.
 - The EPU can supply power to a maximum of six RRUs. The RRU power cable can be connected to any of RRU0 to RRU5 ports on the EPU.
3. Lay out the cable by referring to [7.1 Cabling Requirements](#), and then bind the cable using cable ties.
 4. Label the installed cable by referring to Attaching a Cable-Tying Label.

---End

7.11 Installing a CPRI Fiber Optic Cable

This section describes the procedure for installing a CPRI fiber optic cable.

Prerequisite

Before the installation, single-mode optical modules can be distinguished from multi-mode optical modules in either of the following ways:

- SM and MM labels on an optical module: SM indicates a single-mode optical module, and MM indicates a multi-mode optical module.
- Color of the puller on an optical module: Blue indicates a single-mode optical module, and black or gray indicates a multi-mode optical module.



CAUTION

The optical modules to be installed must match CPRI rates.

Context

A CPRI fiber optic cable transmits CPRI signals between a BBU and an RRU.

For details about CPRI fiber optic cable connections, see the descriptions of connections for the CPRI fiber optic cable in the *BBU3900 Hardware Description*.

Procedure

- Step 1** Lower the pullers of two optical modules, insert one optical module into the CPRI0 port on the RRU and the other optical module into the CPRI port on the BBU, and then raise the pullers, as shown in [Figure 7-21](#).

Figure 7-21 Installing an optical module



ICR06C4002



CAUTION

The performance of an optical module that is exposed to the air for more than 20 minutes may be abnormal. Therefore, you must insert a fiber optic cable into an unpacked optical module within 20 minutes.

- Step 2** Connect the end labeled 1A and 1B of the fiber optic cable to the optical module on the RRU side, as shown in [Figure 7-22](#).

Figure 7-22 Installing a CPRI fiber optic cable

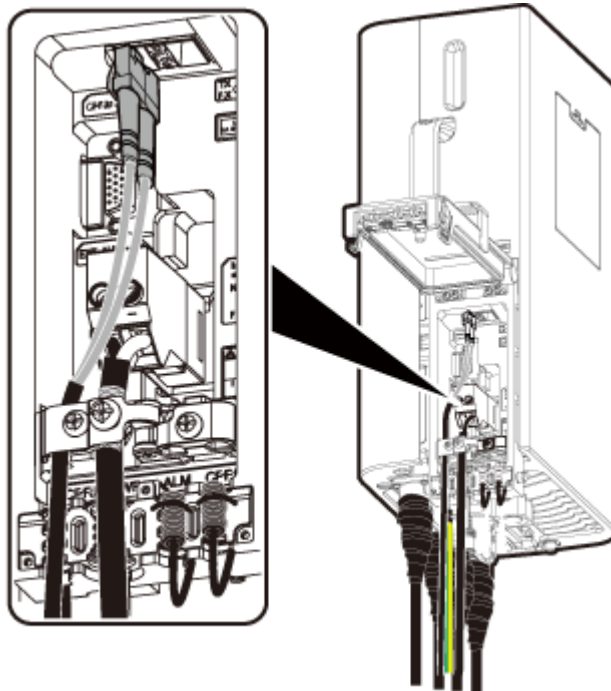

CIR30C4001

 **CAUTION**

Install the fiber optic cable in the cable clip near the power cable to leave some slack at the bend. Tighten the screws on the cable clip to 1.4 N·m (12.39 lbf·in.).

- Step 3** Connect the end labeled 2A and 2B of the fiber optic cable to the optical module on the BBU side.
- Step 4** Lay out the fiber optic cable by referring to [7.1 Cabling Requirements](#), and then bind the cable using cable ties.
- Step 5** Label the fiber optic cable by referring to Attaching an L-Shaped Label.

---End

7.12 Installing an RRU Alarm Cable

This section describes the procedure for installing an RRU alarm cable.

Procedure

- Step 1** Link the DB15 connector at one end of the RRU alarm cable to the EXT_ALM port on the RRU, and link the eight cord end terminals at the other end to the external alarm device, as shown in [Figure 7-23](#).

Figure 7-23 Installing an RRU alarm cable

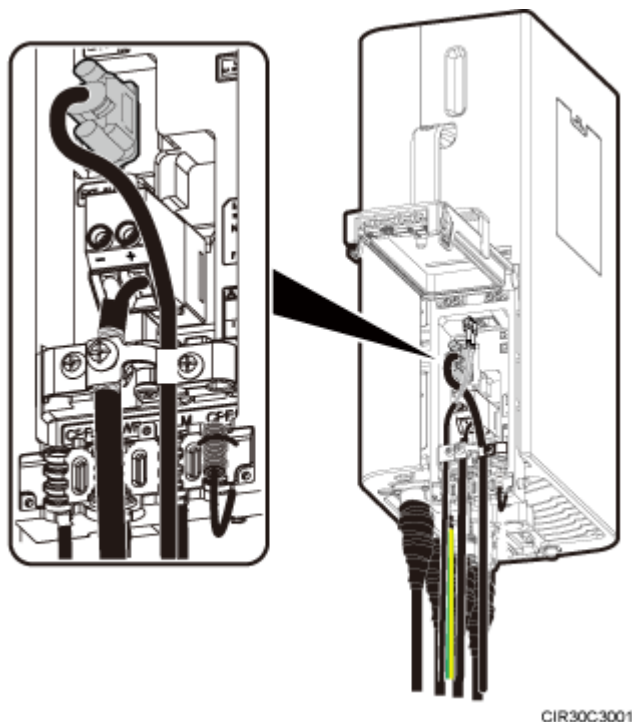

- Step 2** Lay out the cable by referring to [7.1 Cabling Requirements](#), and then bind the cable using cable ties.
- Step 3** Label the installed cable by referring to [Attaching an L-Shaped Label](#).
- End

7.13 Closing the Cover Plate of an RRU Cabling Cavity

This section describes the procedure for closing the cover plate of an RRU cabling cavity.

Procedure

- Step 1** Close clips and tighten the screws on each clip to 1.4 N·m (12.39 lbf·in.) using a torque screwdriver, as shown in [Figure 7-24](#).

Figure 7-24 Closing clips

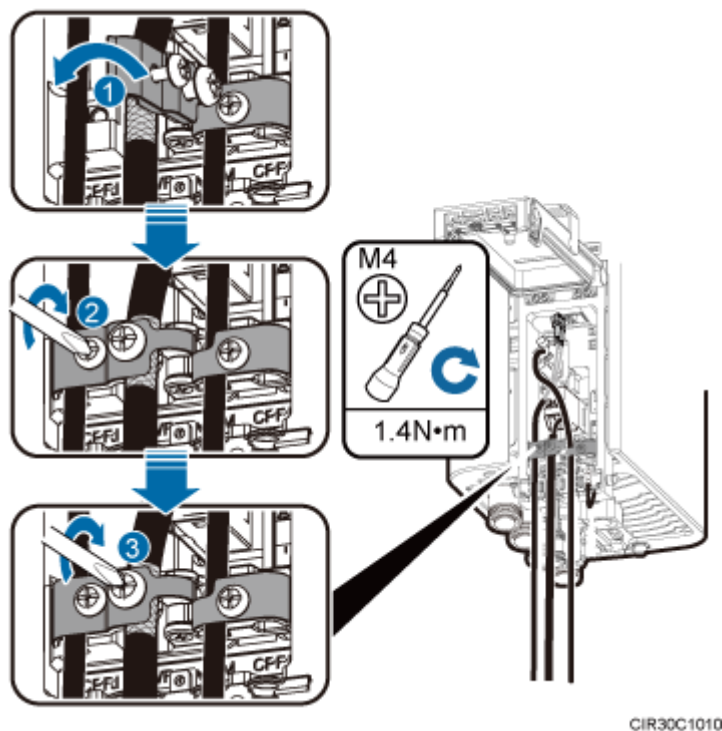

CAUTION

Ensure that the exposed shield layer of the power cable is properly tightened using the clip.

- Step 2** Insert waterproof blocks into vacant cable troughs in the cabling cavity, as shown in [Figure 7-25](#).

Figure 7-25 Correct placement of waterproof blocks

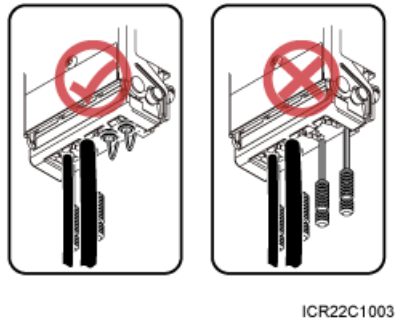

Step 3 Close the cover plate of the RRU cabling cavity and tighten the screws on the cover plate to 0.8 N·m (7.08 lbf·in.) using a torque screwdriver, as shown in **Figure 7-26**.

Figure 7-26 Closing the cover plate of the RRU cabling cavity

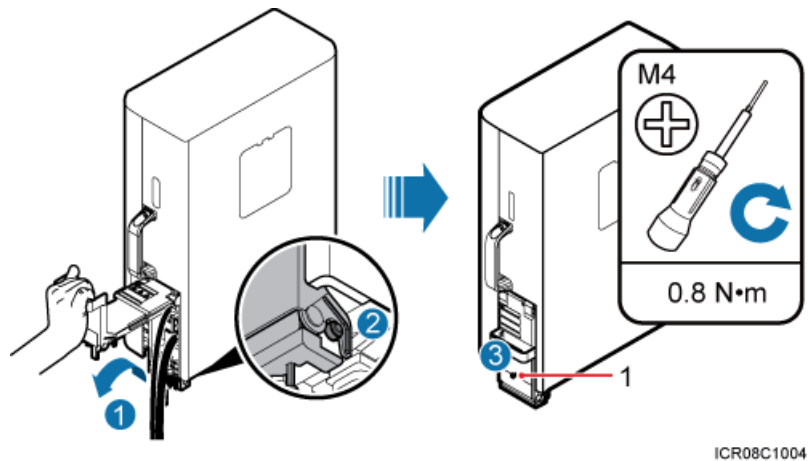

(1) Protection screw

 **CAUTION**

- Before tightening the screws on the cover plate, ensure that cables and waterproof blocks are properly inserted into troughs.
 - Tighten the screws on the cover plate in the sequence shown in the figure.
-

Step 4 Take off the ESD gloves, and pack up all the tools.

----End

8 Checking the RRU Hardware Installation

After an RRU is installed, check the hardware installation.

Table 8-1 provides the checklist for the RRU hardware installation.

Table 8-1 Checklist for the RRU hardware installation

SN	Item
1	The position for each device conforms to the engineering drawing and meets the space requirement. Sufficient space is reserved for equipment maintenance.
2	The RRU is securely installed.
3	The cover plate is securely installed on the RRU cabling cavity.
4	Waterproof blocks are securely installed in vacant cable troughs of the RRU cabling cavity, and the cover plate for the cabling cavity is securely installed. In addition, vacant RF ports are covered with dustproof caps and the caps are tightened.
5	There are no connectors or joints on each power cable or PGND cable.
6	The terminals at two ends of each power cable or PGND cable are securely soldered or crimped.
7	None of power cables and PGND cables can be short-circuited or reversely connected. In addition, these cables are not damaged or broken.
8	Power cables and PGND cables are separately bound from other cables.
9	The protection grounding of the RRU and the surge protection grounding of the building share one group of ground conductors.
10	The connectors of each signal cable are intact and securely linked, and these cables are not damaged or broken.
11	Labels are correct, legible, and complete at both ends of each cable, feeder, and jumper.

9 Powering On an RRU

After all the devices are installed, check the power-on status of an RRU.

CAUTION

After you unpack an RRU, you must power on it within 24 hours. If you power off the RRU for maintenance, you must restore power to the RRU within 24 hours.

Figure 9-1 shows the RRU power-on check process.

Figure 9-1 RRU power-on check process

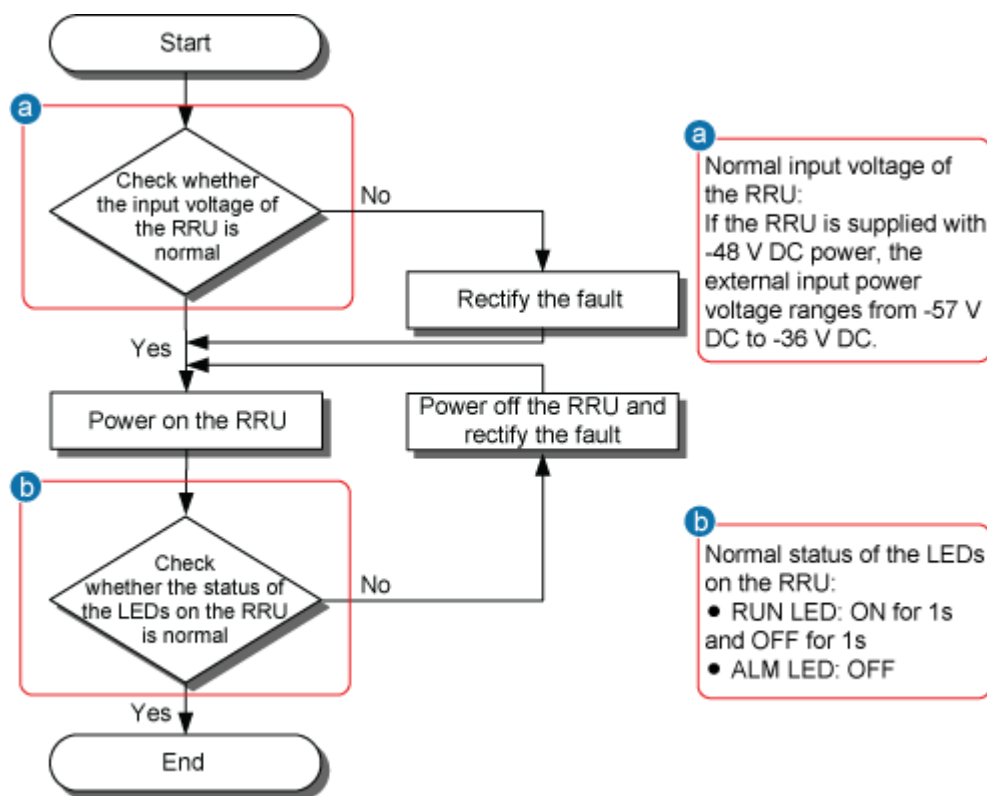

IPR06C0003

10 Appendix

About This Chapter

This section describes the procedure for adding an easy power receptacle (pressfit type) connector.

[10.1 Adding an Easy Power Receptacle \(Pressfit Type\) Connector to the RRU Power Cable on the RRU Side](#)

This section describes the procedure for adding an easy power receptacle (pressfit type) connector to the RRU power cable on the RRU side.

10.1 Adding an Easy Power Receptacle (Pressfit Type) Connector to the RRU Power Cable on the RRU Side

This section describes the procedure for adding an easy power receptacle (pressfit type) connector to the RRU power cable on the RRU side.

Procedure

Step 1 [Figure 10-1](#) shows the cable diagram on labels.

Figure 10-1 Cable diagram on labels

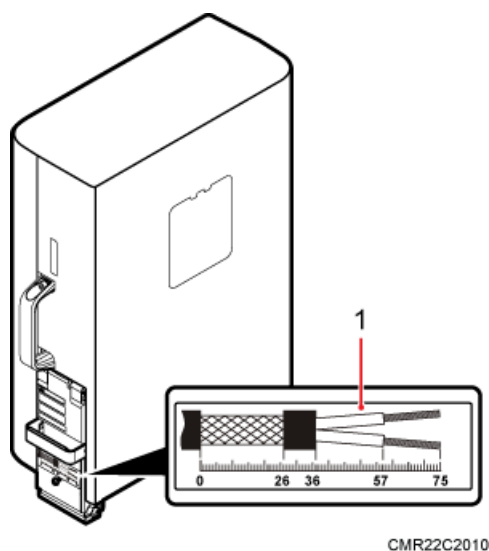

(1) Cable diagram on labels

Step 2 Determine the length of the power cable for different operations based on the labels, as shown in [Figure 10-2](#).

Figure 10-2 Determining the length of the power cable

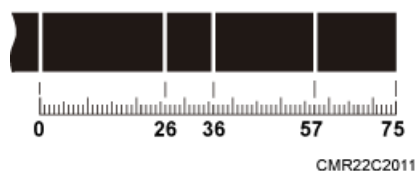

Step 3 Strip the specified length of the sheath off the power cable, as shown in [Figure 10-3](#).

Figure 10-3 Stripping the specified length of sheath

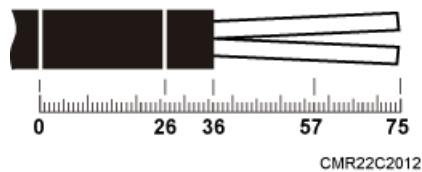

Step 4 Strip a specified length of sheath off each core wire. The length must be consistent with the length of the notch in the easy power receptacle (pressfit type) connector, as shown in [Figure 10-4](#).

Figure 10-4 Stripping the sheath off each core wire

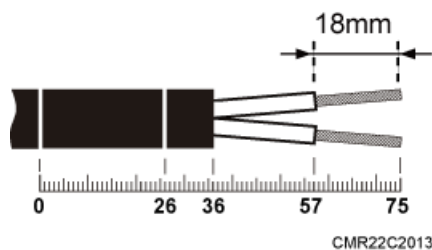
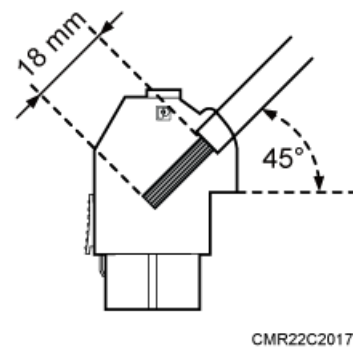

Figure 10-5 Matched length



Step 5 Add an easy power receptacle (pressfit type) connector to two core wires.

1. Tighten the screws using a Phillips screwdriver, as shown in [Figure 10-6](#).

Figure 10-6 Tightening screws

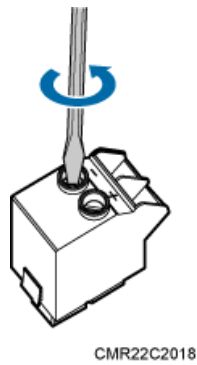

2. Connect the blue core wire labeled NEG(-) to the - port and the black/brown core wire labeled RTN(+) to the + port on the easy power receptacle (pressfit type) connector, and then tighten the screws using a Phillips screwdriver, as shown in **Figure 10-7**.

Figure 10-7 Adding an easy power receptacle (pressfit type) connector to two core wires

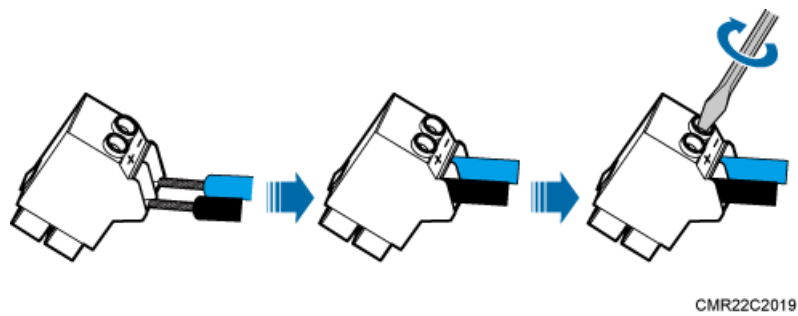

- Step 6** Strip the specified length of the sheath off the power cable to expose the intact shield layer, as shown in **Figure 10-8**.

Figure 10-8 Stripping the sheath off the power cable

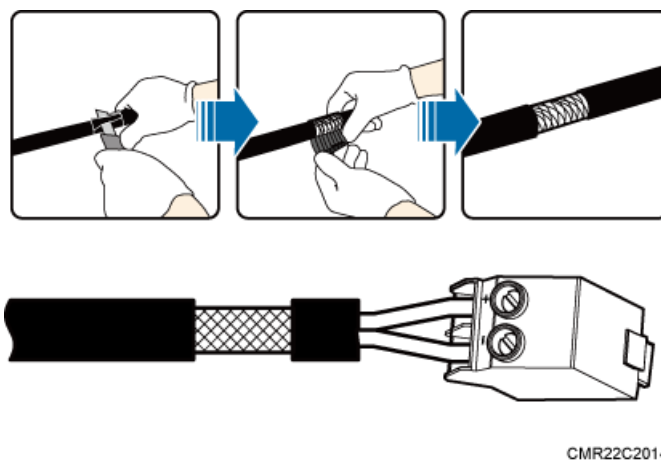

 **CAUTION**

Each core wire is exposed outside the easy power receptacle (pressfit type) connector for 1.5 mm (0.059 [in.]), as shown in [Figure 10-9](#).

Figure 10-9 Inserting core wires into the easy power receptacle (pressfit type) connector

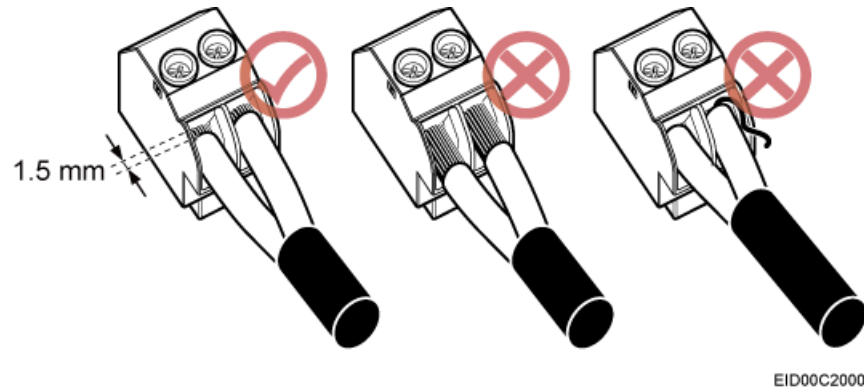

---End