

RTN 360 V100

Quick Installation Guide

Date: 2014-02-15



Copyright © Huawei Technologies Co., Ltd. 2014. All rights reserved.

No part of this document may be reproduced or transmitted in any form or by any means without prior written consent of Huawei Technologies Co., Ltd.

Huawei Technologies Co., Ltd.

Address: Huawei Industrial Base
Bantian, Longgang
Shenzhen 518129
People's Republic of China

Website: <http://www.huawei.com>

Email: support@huawei.com

Safety Precautions

Thunderstorms

Do not work with electrical current or work in elevated or exposed locations during a thunderstorm.

Extreme weather conditions

RTN 360 is usually installed outdoors. If weather conditions are extreme during an installation, personnel should follow the related local guidelines and regulations to safeguard personal health and safety.

Elevated locations

RTN 360 is usually installed in an elevated location, for example, on the rooftop of a building. For installation in elevated locations, installation personnel must:

- Have the proper training and qualifications, and meet health requirements.
- Wear helmets, safety belts, and anti-slip footwear.
- Wear clothing and gloves appropriate to weather conditions.
- Work in teams of two or more.
- Test hoisting tools before use.
- Avoid installation during extreme weather conditions, such as during thunderstorms, blizzards, or gales.

In addition, all site visitors must wear helmets.

Microwave

High-power radio frequency signals are harmful. Avoid exposure to transmission from the antennas of microwave equipment that has the radiation warning symbol (). When you are installing or performing maintenance on an antenna located on a tower that has multiple antennas, avoid exposure to radiation from other antennas.

High temperature

If the ambient temperature reaches 55° C, the surface temperature of an RTN 360 may exceed 70° C.

Therefore, wear protective gloves when handling the RTN 360. A high-temperature warning label () is attached to each RTN 360.

Handling of RTN 360 or mounting kits

Wear clean gloves when handling the RTN 360 or mounting kits.

Corrosion

Anti-corrosion measures are required if an RTN 360 is installed in a location that is prone to corrosion. Contact the local Huawei office for details. A location is prone to corrosion if it is:

- Within 3.7 km of an ocean or a salt water lake
- Within 3 km of a heavy pollution source, such as a smelting factory or coal mine
- Within 2 km of a medium pollution source, such as a chemical, rubber, or electroplating plant
- Within 1 km of a light pollution source, such as a food/leather processing plant or heating boiler

Port protection

- Fasten PG covers onto the network ports of an RTN 360, and protect unused ports with caps.
- Retain removed caps for future use.

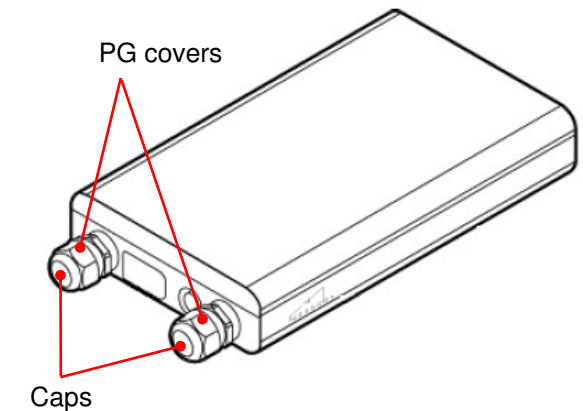

Unpacking

- After unpacking an RTN 360, power it on within 24 hours.
- Do not power off an RTN 360 for more than 24 hours during maintenance.

Minimal installation space

The following figure illustrates the minimal installation space required for an RTN 360.

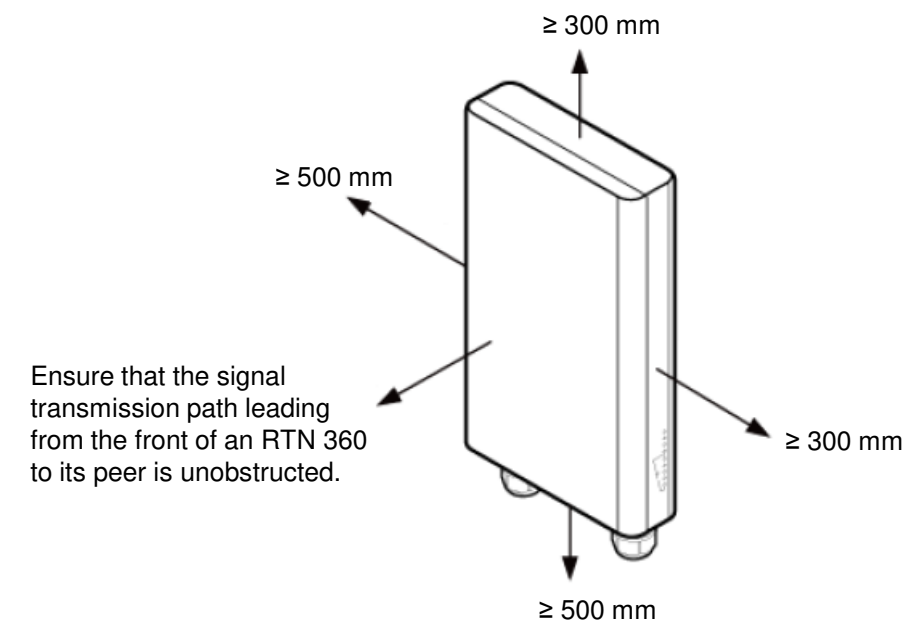

Installing an RTN 360

Equipment Components

A Appearance and ports

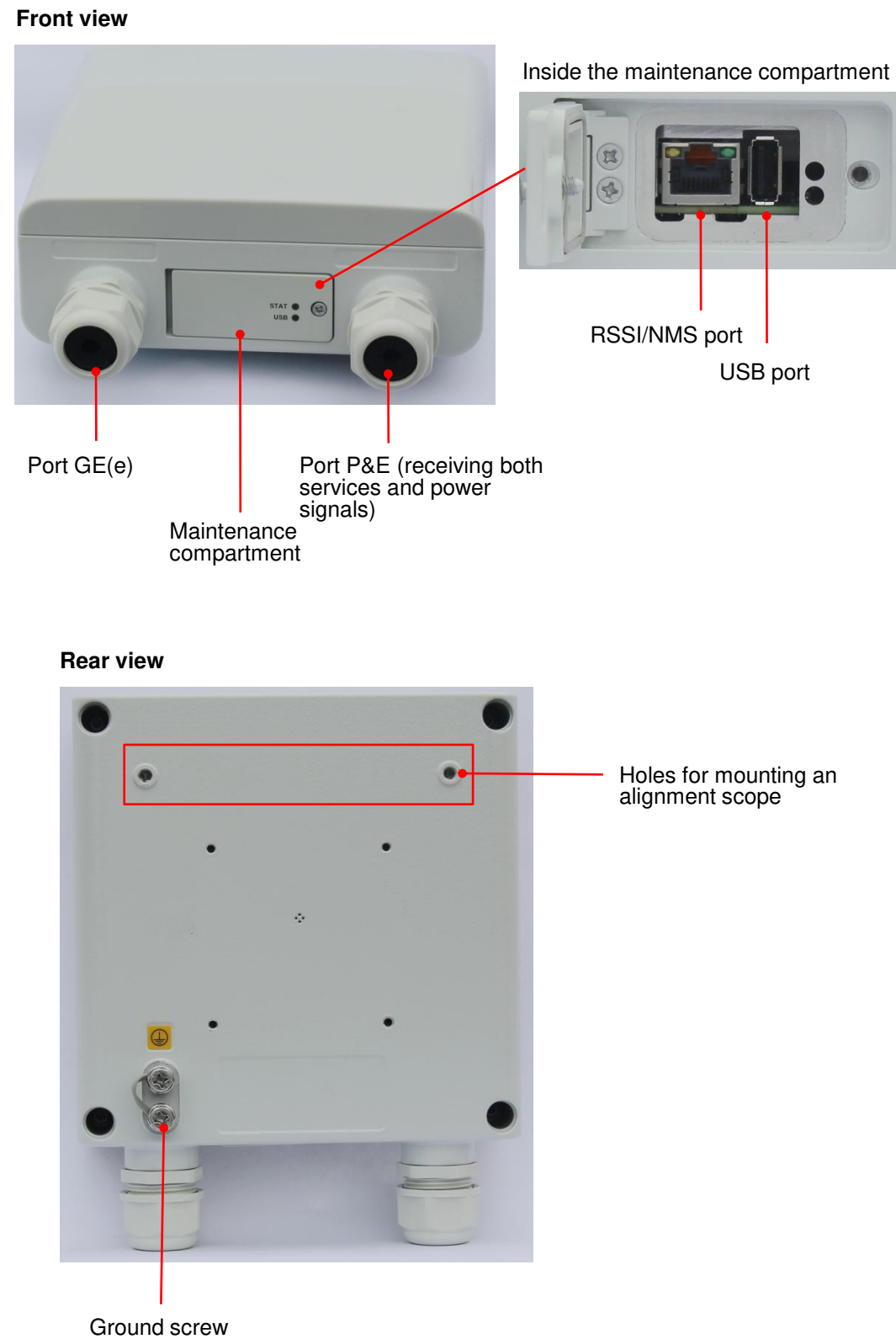

B Mounting kits



1. Attachment plate (installed before delivery)
2. Hose clamp (used when an RTN 360 is installed on a pole)
3. Azimuth adjustment nut
4. Fastener (with holes used for installing an RTN 360 on a wall or pole)
5. Elevation adjustment nut

C Ground cable

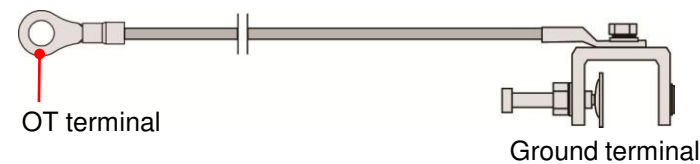

NOTE

- The ground terminal can connect to a ground bar or U-shaped ground clip.
- For information about how to connect the ground terminal to a U-shaped ground clip, see the usage description document supplied with the clip.

D USB flash drive



NOTE

- The recommended USB flash drive is a 4 GB Netac U208. If a different model or capacity is required, contact the local Huawei office. USB flash drives not meeting requirements may be incompatible.
- The appearance of the shipped USB flash drive may differ from that shown here.

E Alignment scope

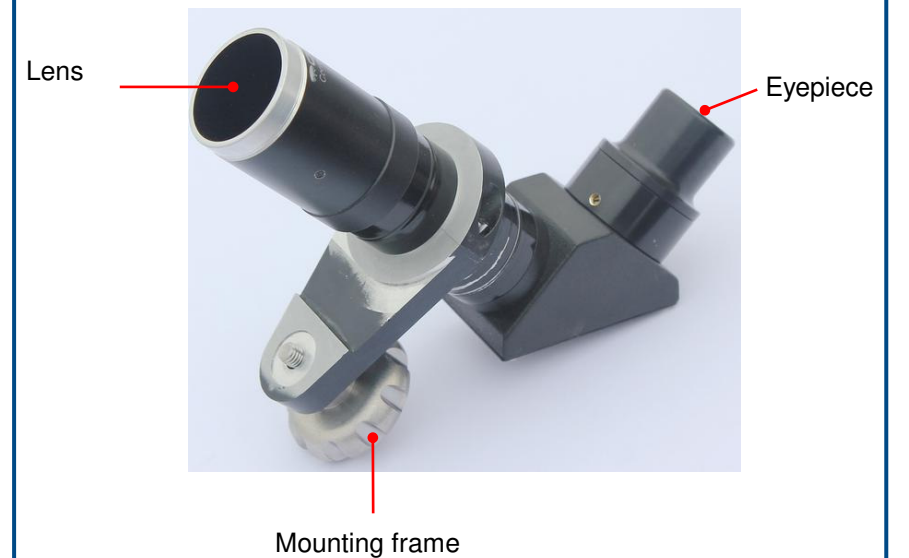

Terminating an Outdoor Network Cable with Shielded RJ45 Connectors

1 Prepare the following tools.



RJ45 connector crimping tool



Diagonal pliers

2 Prepare an outdoor network cable and shielded RJ45 connectors.

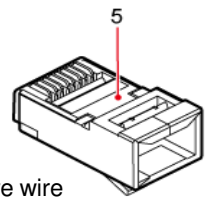
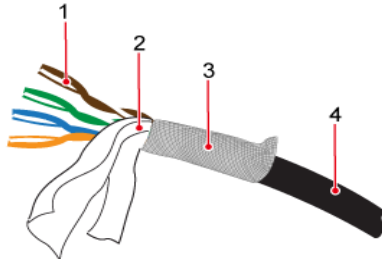

1. Core wire
2. Aluminum foil
3. Braid shield
4. Outer jacket
5. Shielded RJ45 connector

3 Strip the cable.

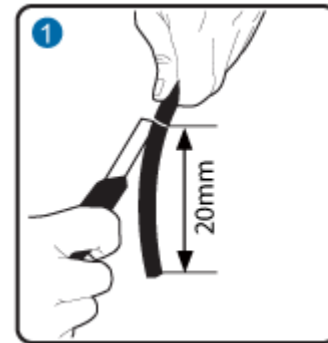

Length of the stripped cable: 20 mm

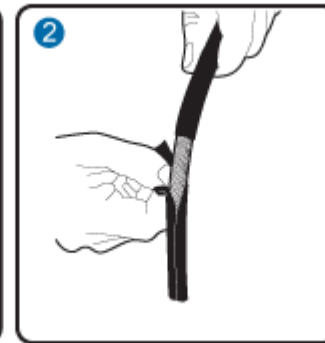

Remove the outer jacket.

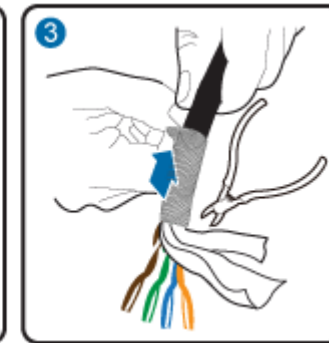

Strip off the braid shield and cut the aluminum foil and unwanted materials.

NOTE

When stripping off the outer jacket, take care not to damage the braid shield or aluminum foil.

4 Arrange the core wires according to the pin assignments and cut them neatly (exposing a length of 12 mm).

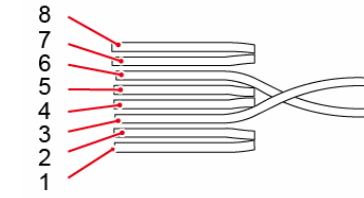

- 8: brown
- 7: white and brown
- 6: green
- 5: white and blue
- 4: blue
- 3: white and green
- 2: orange
- 1: white and orange

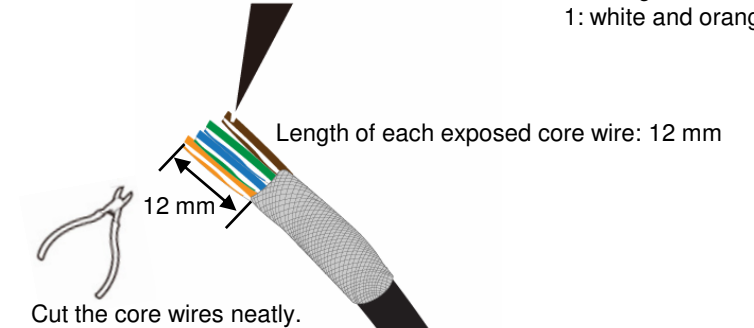

Cut the core wires neatly.

5 Insert the arranged core wires into an RJ45 connector according to the pin assignments and crimp the connector with the crimping tool.

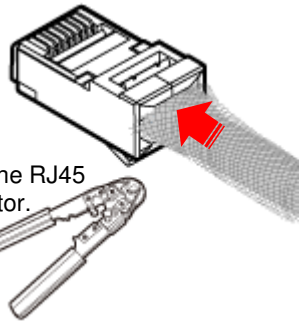

Crimp the RJ45 connector.

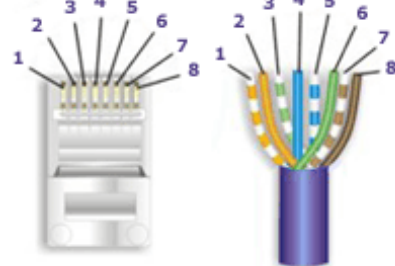

Pin assignments of an RJ45 connector

6 Cut off the exposed braid shield and materials along the edge of the connector.

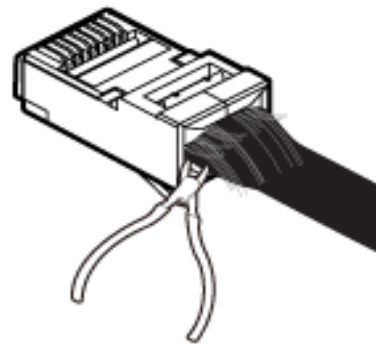

Cut off the exposed braid shield and materials.

7 Terminate a connector on the other end of the network cable, and then test the cable for continuity using a network cable tester. The pin assignments of the connectors at the two ends must be the same. Outdoor network cables are straight-through cables.

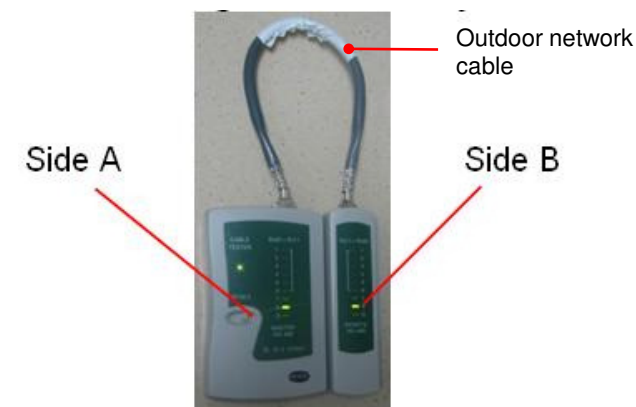

NOTE

Generally, straight-through cables are used with the RTN 360. Crossover cables are required only when the BTS3902E and BTS3202E supplies power over Ethernet to the RTN 360. In this case, the pin assignments of the connector at the other end are as follows:

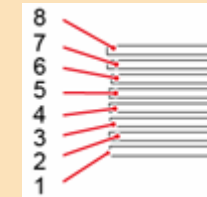

- 8: brown
- 7: white and brown
- 6: orange
- 5: white and blue
- 4: blue
- 3: white and orange
- 2: green
- 1: white and green

NOTE

Before crimping, ensure that the core wires are fully inserted in the RJ45 connector.

Terminating a Ground Cable with an OT Terminal

1 Strip the ground cable.

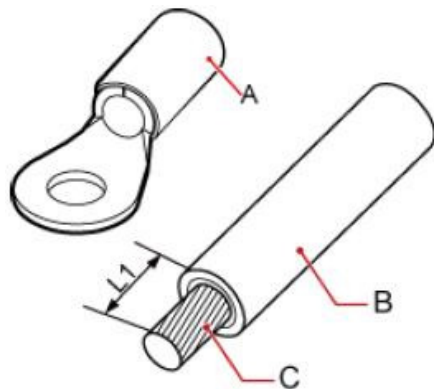

- A: OT terminal
- B: ground cable
- C: exposed cable conductor
- L1: length of the exposed cable

NOTE

When you are skillful, you can determine L1 based on the length of the OT terminal lug.

CAUTION

When stripping off the insulation layer of the ground cable, take care not to damage or nick the metal conductor of the cable.

Mapping between the cross-sectional area of a cable conductor (C) and the length of an exposed cable (L1)

Cross-sectional Area of C (mm ²)	L1 (mm)
1	7
1.5	7
2.5	7
4	8
6	9
10	11
16	13
25	14
35	16
50	16

2 Fit the exposed cable into the OT terminal.

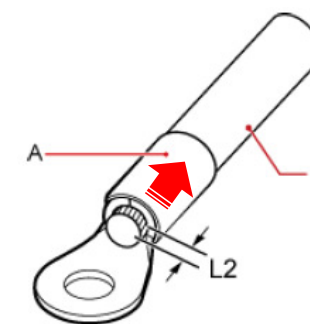

CAUTION

Ensure that the cable conductor does not protrude more than 2 mm from the OT terminal.

3 Crimp the OT terminal lug.

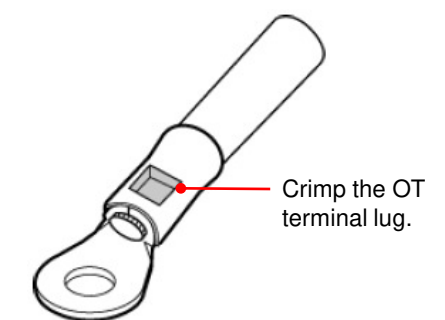

NOTE

The impression left from crimping the lug may differ depending on the crimping tool used.

Installing an RTN 360

1 Installing an RTN 360 at the Edge of a Mobile Backhaul Network

Installation procedure

- 1 Install an RTN 360 on a pole or wall.
- 2 Install the ground cable.
- 3 Connect one end of an outdoor network cable to port P&E on the RTN 360.

CAUTION

PoE supports a maximum distance of 100 meters.

Commissioning procedure

- 4 Align the RTN 360 with its peer.
- 5 Connect the other end of the outdoor network cable to port WAN on a Dock.

NOTE

Traffic transmitted to the opposite wireless equipment is forwarded by port LAN0 on the Dock.

CAUTION

Use clips to fix any indoor sections of the outdoor network cables that connect to ports WAN and LAN0 on the Dock.

- 6 Load commissioning data to the RTN 360 using the Web LCT or USB flash drive.
- 7 Ensure that the received signal level (RSL) of the RTN 360 meets the requirement.
- 8 Verify the installation.

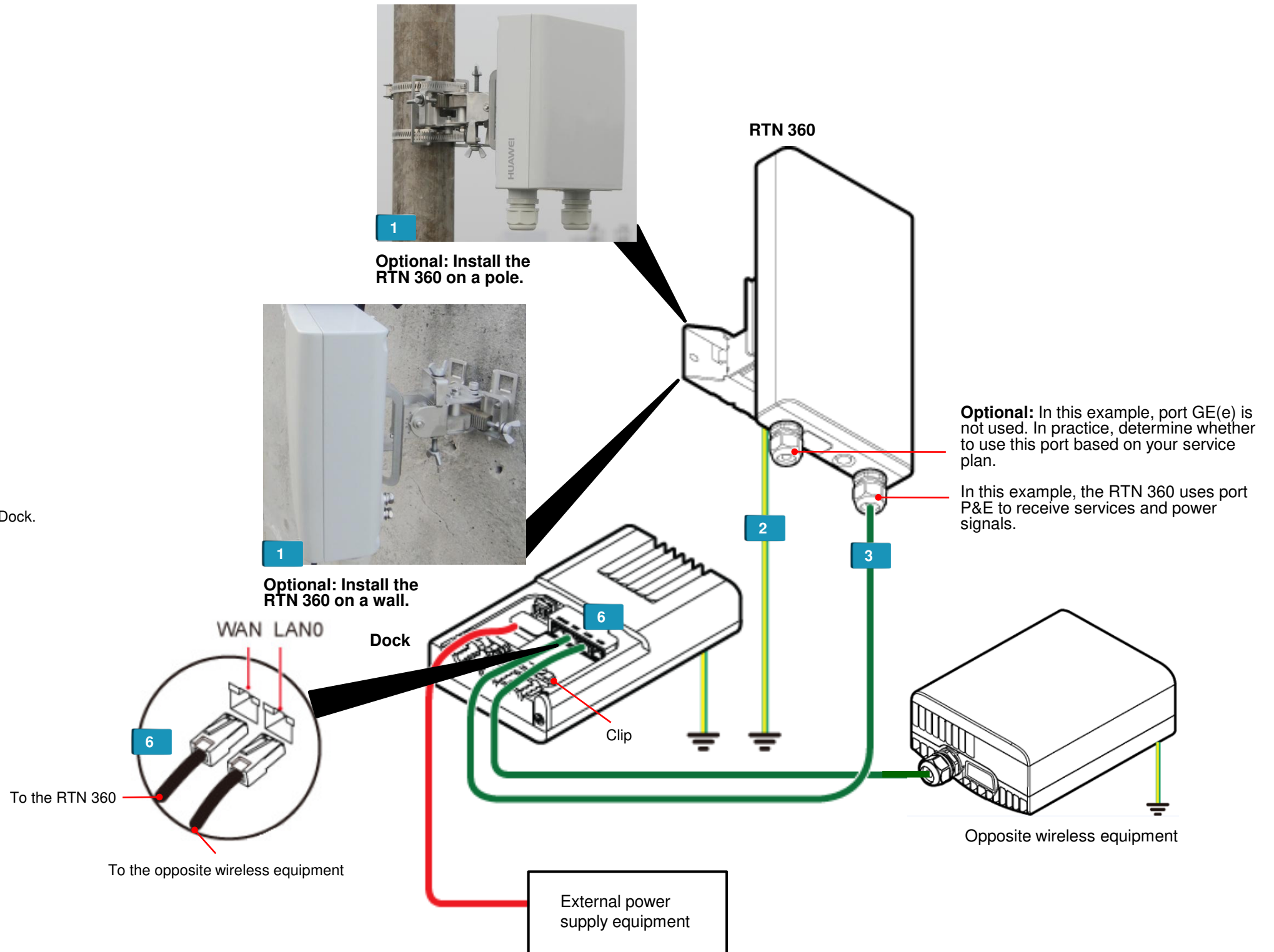

2 Installing RTN 360s at 2x(1+0) Aggregation Sites

Installation procedure

- 1 Install two RTN 360s on a pole or wall.
- 2 Install their respective ground cables.
- 3 Connect an outdoor network cable to port P&E on each RTN 360.

CAUTION

PoE supports a maximum distance of 100 meters.

Commissioning procedure

- 4 Align each RTN 360 with its peer.
- 5 Connect one of the two outdoor network cables to port WAN on a Dock and the other to port LAN1 on the Dock.

NOTE

Traffic transmitted to the opposite wireless equipment is forwarded by port LAN0 on the Dock.

CAUTION

Use clips to fix any indoor sections of the outdoor network cables that connect to ports WAN, LAN0, and LAN1 on the Dock.

- 6 Load commissioning data to the RTN 360s using the Web LCT or USB flash drive.
- 7 Ensure that the RSLs of the two RTN 360s meet the requirements.
- 8 Verify the installation.

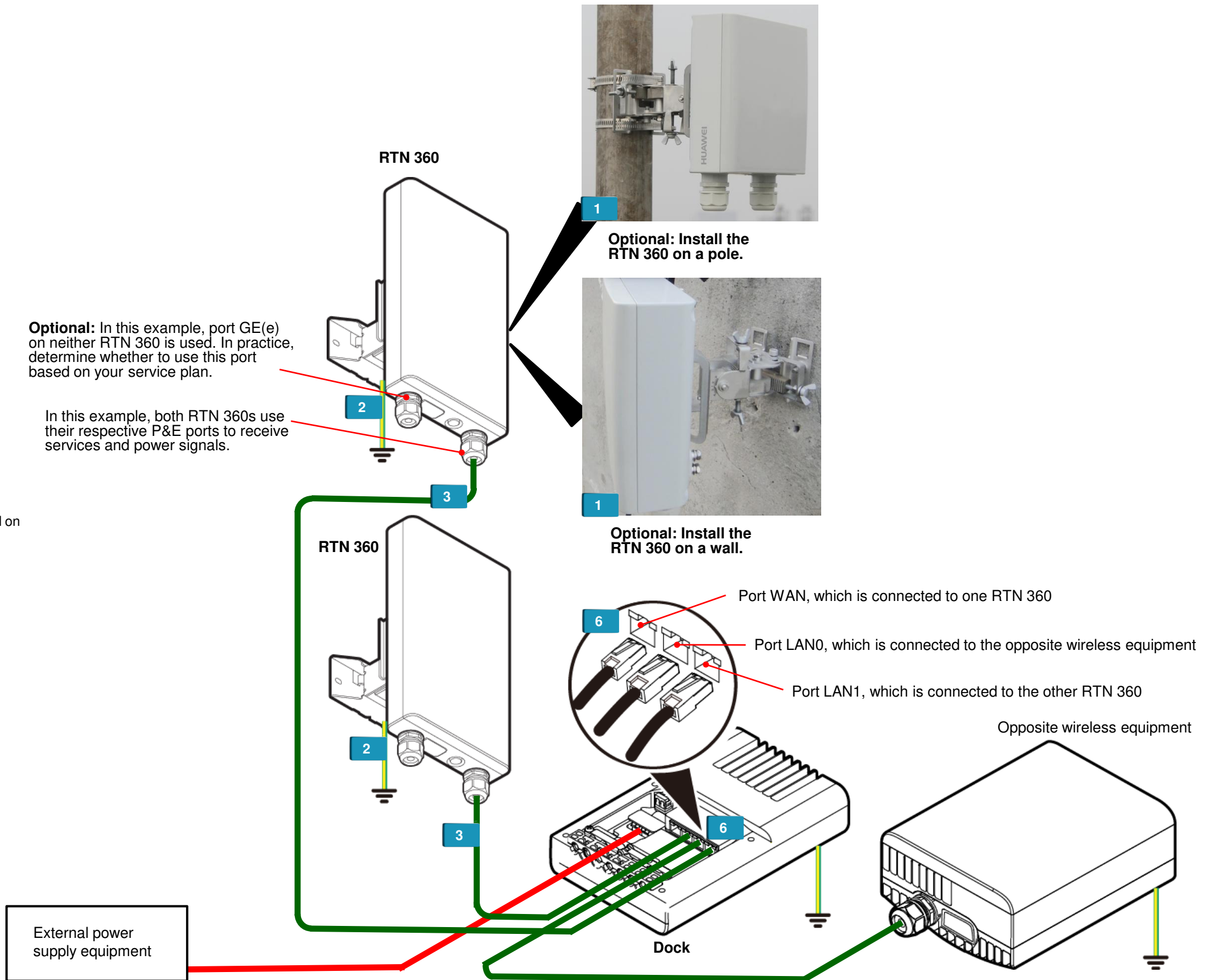

References for Installation

Optional: Installing an RTN 360 on a Pole

- 1 Pass the hose clamps through the fastener and fix the hose clamps on a pole using the screws of the hose clamps.

NOTE

Before fixing the hose clamps, ensure that the azimuth faces the peer site.

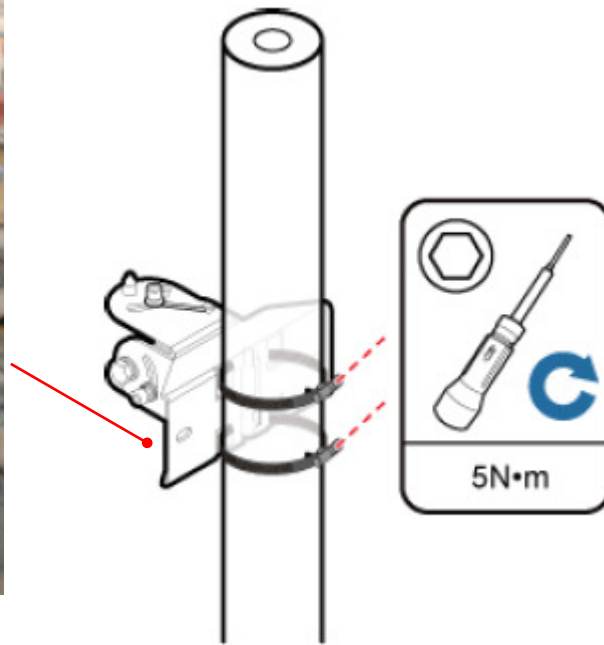
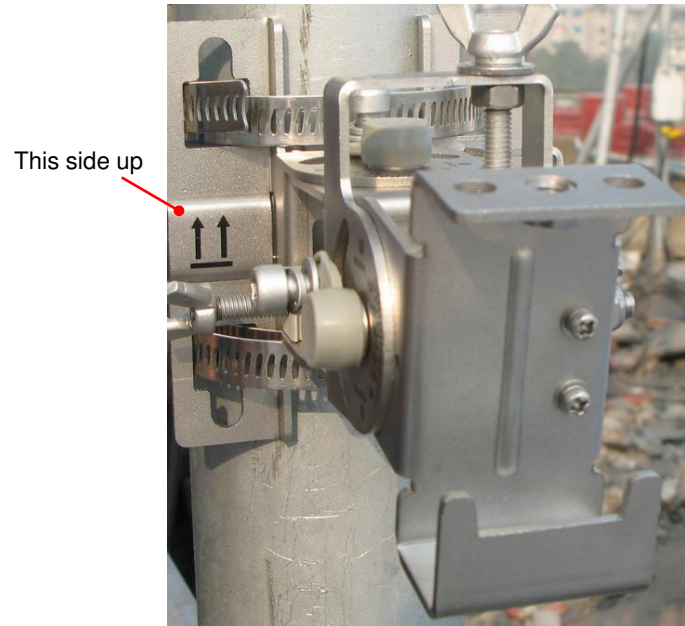

- 2 Install the RTN 360 box securely on the fastener.

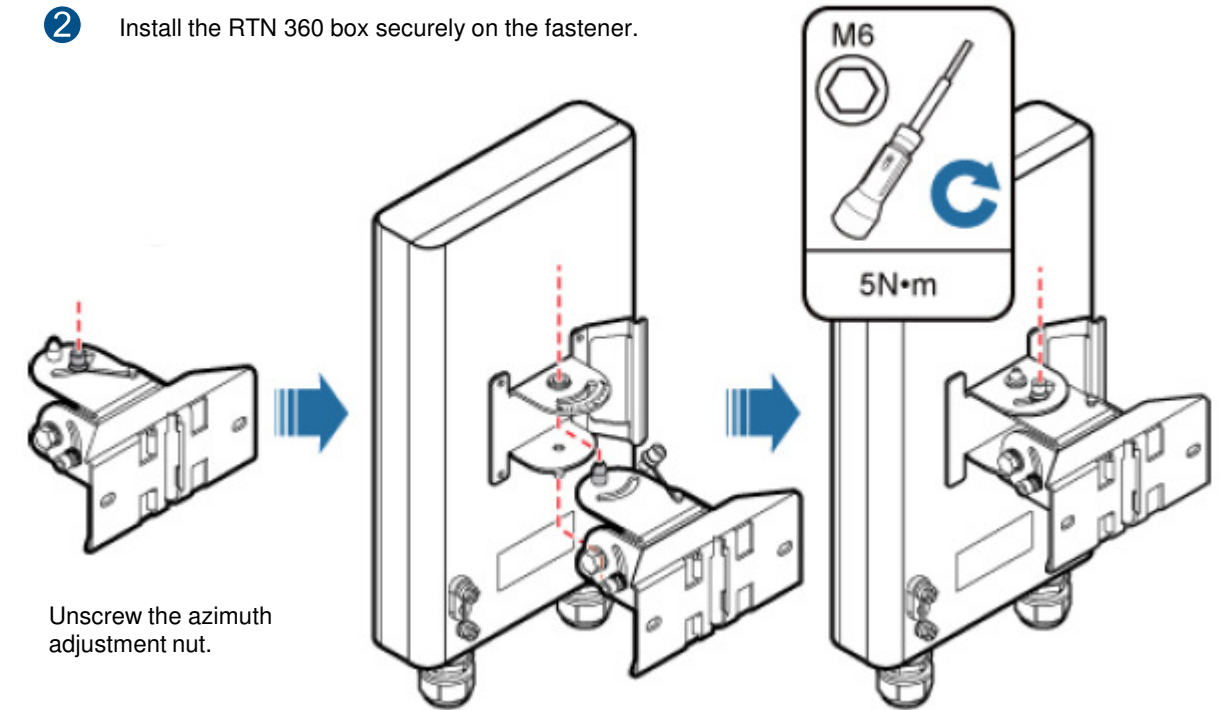

Unscrew the azimuth adjustment nut.

Hook the RTN 360 box (with the attachment plate installed) to the fastener along the dowel.

Tighten the azimuth adjustment nut using a hex key.

Optional: Installing an RTN 360 on a Wall

- 1 Press the fastener against a wall, level the installation location using a level, and mark locating points using a marker.

- 3 Install the fastener onto the expansion bolts, place a flat washer, a spring washer, and a nut on each expansion bolt, and then tighten the nuts.

- 4 Install the RTN 360 box securely on the fastener.

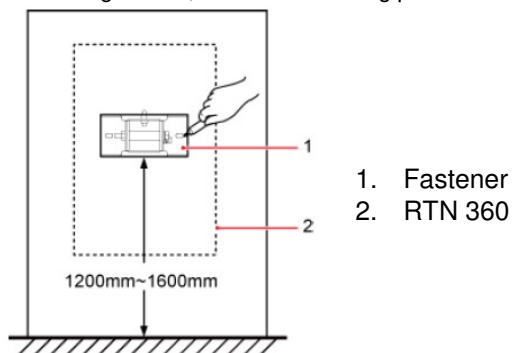

- 2 Drill holes and install expansion bolts at the locating points.

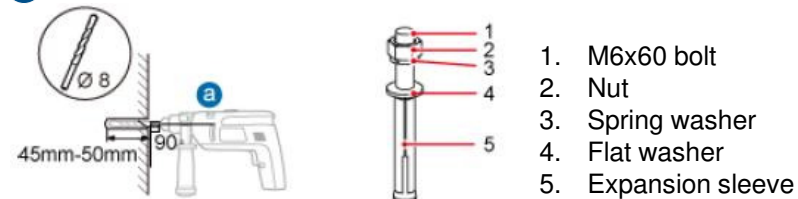
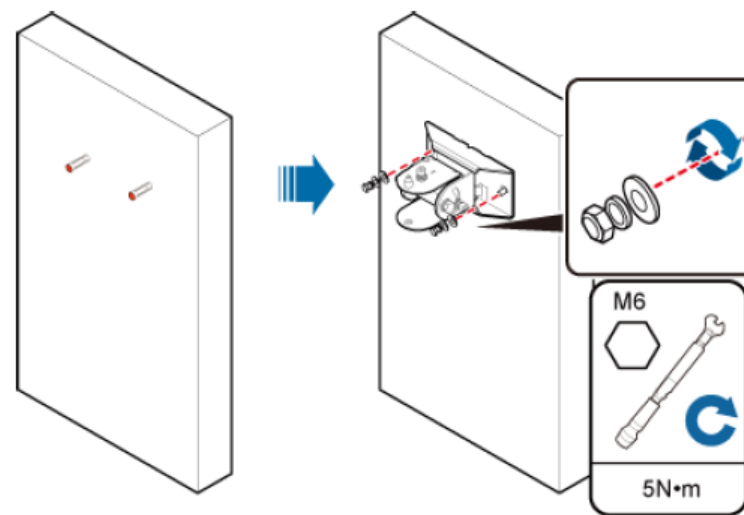

CAUTION

Ensure that each expansion bolt protrudes from 8 mm to 12 mm.

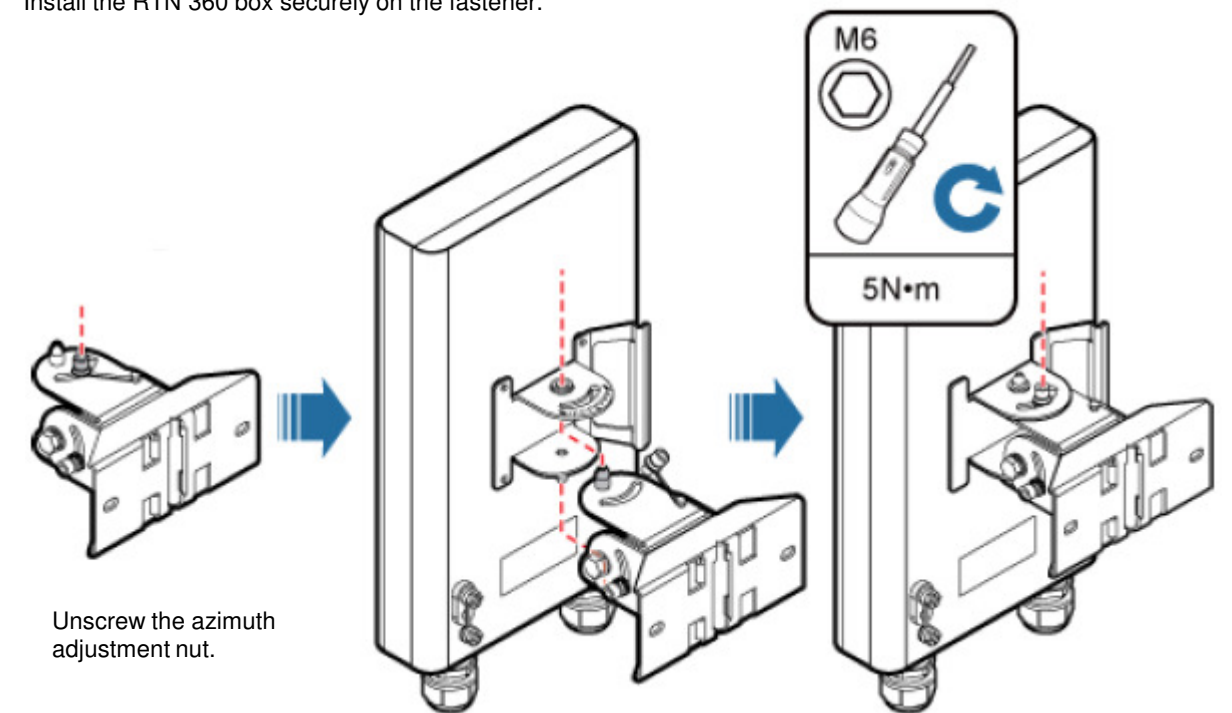

Unscrew the azimuth adjustment nut.

Hook the RTN 360 box (with the attachment plate installed) to the fastener along the dowel.

Tighten the azimuth adjustment nut using a hex key.

References for Installation

Installing Cables

1 Install a ground cable.

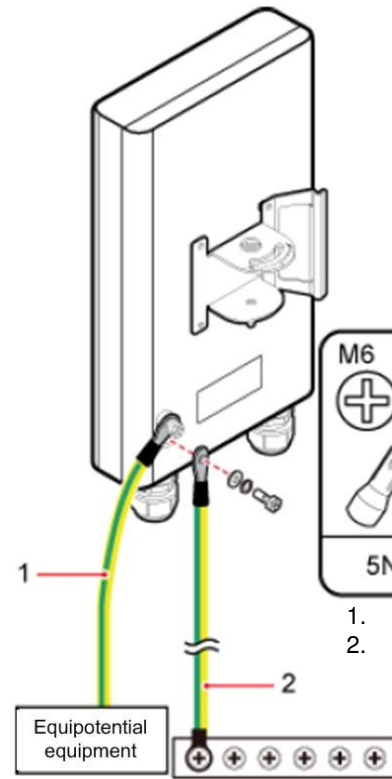

Ensure that the OT terminal of the ground cable is correctly installed.

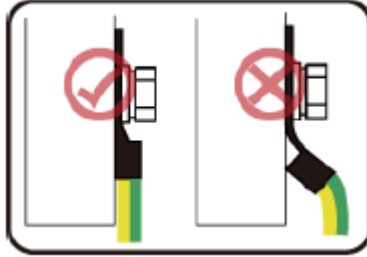

1. Optional: Connect the ground cable to equipotential equipment.
2. Optional: Connect the ground cable to a ground bar.

NOTE

After installing the ground cable, apply antirust paint to the ground bar or point.

2 Install an outdoor network cable.

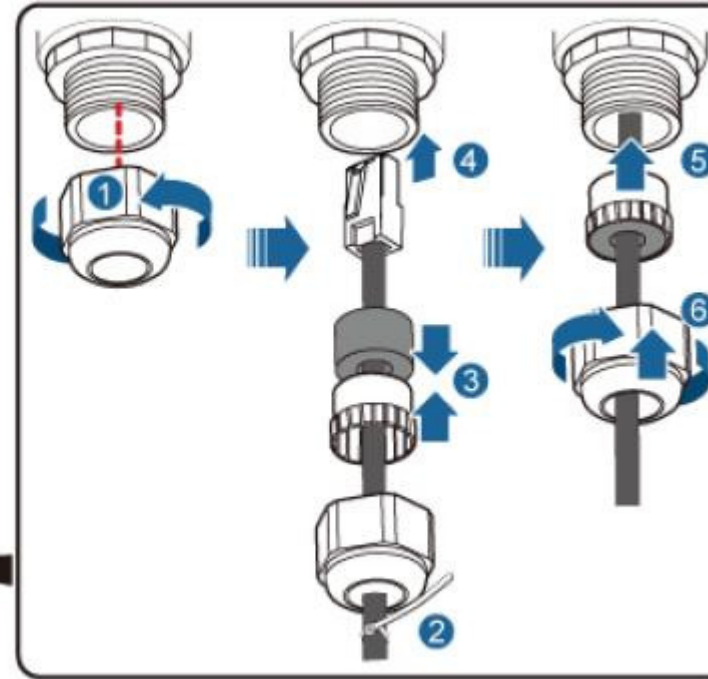
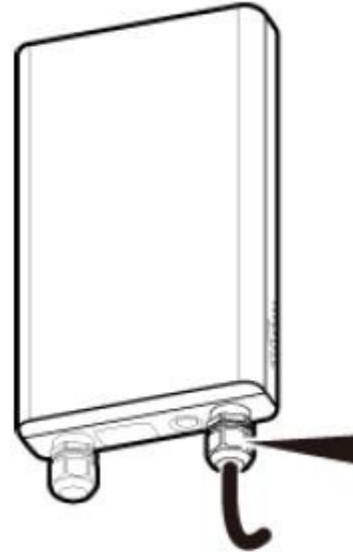

1. Unscrew the PG cover installed on port P&E of the RTN 360 using a 1.8 N·m torque wrench (rotating the wrench counterclockwise).

2. Attach a cable tie to the network cable to prevent the PG cover from sliding down.

3/4. Route the network cable through the PG cover and connect the cable to port P&E of the RTN 360.

5/6. Insert the plug of the network cable into port P&E and screw the PG cover.

NOTE

The procedure for installing an outdoor network cable on port GE(e) of an RTN 360 is the same as the procedure described here.

Laying out Cables

General requirements

1. Bend radius
For power and PGND cables, ensure a bend radius of at least three times the cable diameter.
2. Cable binding
 - Bind different cables separately, with a minimum distance of 30 mm.
 - Bind cables securely and neatly, without damaging the cable jackets.
 - Ensure that cable ties face the same direction and are aligned in rows horizontally.
 - Cut off the excess of each indoor cable tie but leave a slack of about 5 mm for each outdoor cable tie. Ensure that all cut surfaces do not have sharp edges.
 - After installing cables, attach labels or tags to the two ends of each cable.
3. Safety
 - Lay out cables away from sharp objects or jagged walls, or protect cables using conduit.
 - Lay out cables away from heat sources, or add heat-insulation materials between cables and heat sources.
 - At turns or near equipment, allow sufficient slack in the cables and coil them (with a diameter of about 0.6 meters) for future use.
4. Indoor cable routing
 - Route cables into equipment rooms through feeder windows.
 - Form drip loops outside feeder windows and ensure a bend radius equal to or greater than the required minimum bend radius.
 - Seek help indoors when routing cables into equipment rooms.
 - Waterproof feeder windows.

NOTE

The requirements for indoor cable routing apply if any section of cable will be routed indoors.

Requirements for laying out cables outdoors

Route cables along the planned path, use outdoor cable ties to bind cables properly and neatly at intervals of about 1 meter, and cut off the excess of each cable tie without leaving sharp edges (ensuring a slack of about 5 mm).

Requirements for laying out PGND cables

- Connect PGND cables of co-sited devices to the same ground bar.
- Do not route PGND cables overhead in outdoor scenarios.
- Bind PGND cables separately from outdoor network cables and keep a certain distance between the bundles.
- Do not add switches or fuses on PGND cables.

Installing sign plate labels

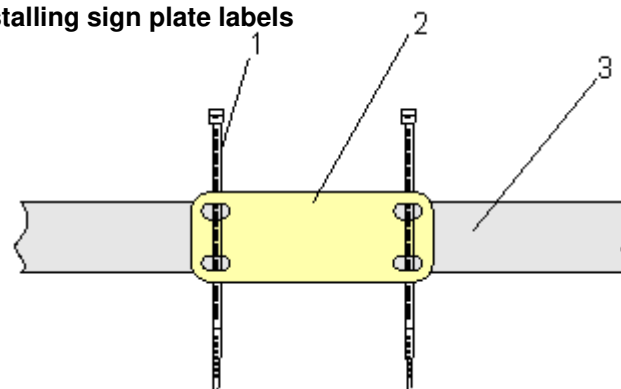

Attach a sign plate label to each cable end. To do so, pass cable ties through the holes in the label and attach it to one cable end, about 100 mm to 200 mm away from the connector.

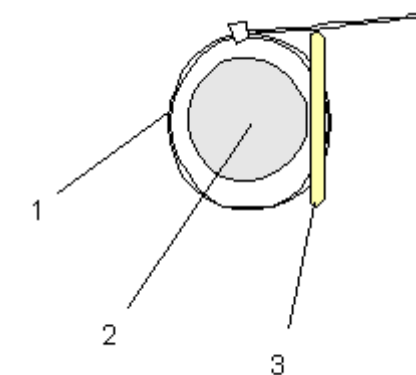

1. Outdoor cable tie
2. Sign plate label
3. Cable

Tighten the cable ties to fix the label on the cable. Then, cut off the excess of each cable tie, leaving a slack of about 5 mm and no sharp edges.

Aligning an RTN 360

1 Install the alignment scope.

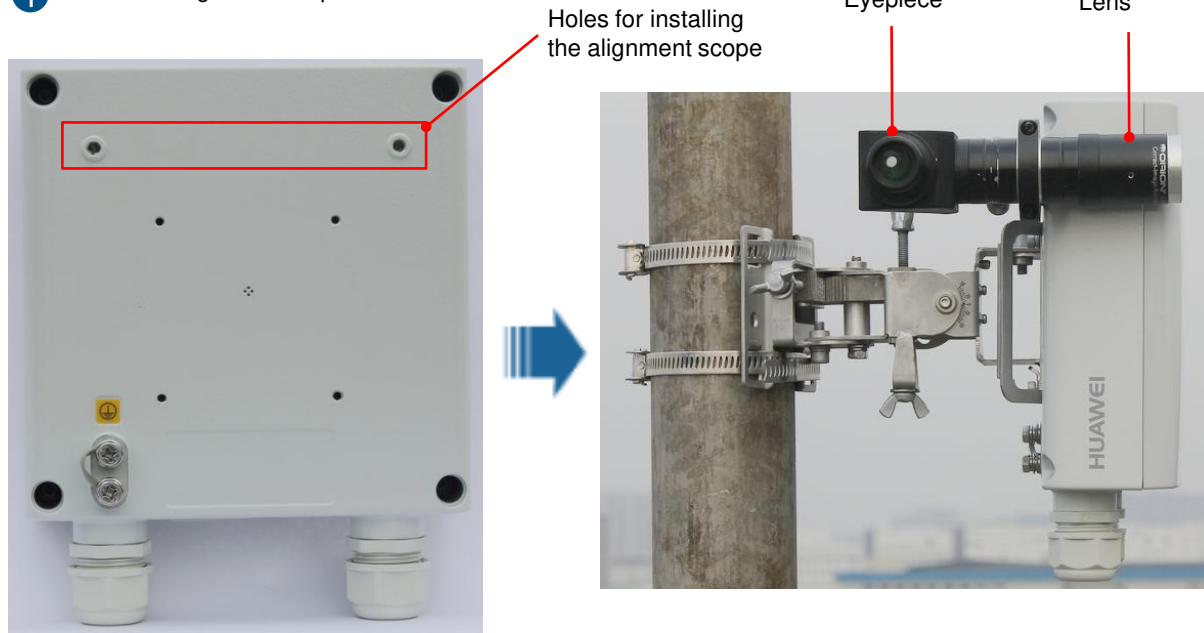

2 Adjust the azimuth and elevation of the RTN 360 by rotating the azimuth and elevation adjustment nuts.

By rotating azimuth adjustment nut (nut 1), you can adjust the azimuth of the RTN 360 from -50° to $+50^{\circ}$.



By rotating the elevation adjustment nut (nut 2), you can adjust the elevation of the RTN 360 from -50° to $+50^{\circ}$.

3 Adjust the azimuth and elevation of the local RTN 360 slowly to move the crosshair of the alignment scope to the peer RTN 360.

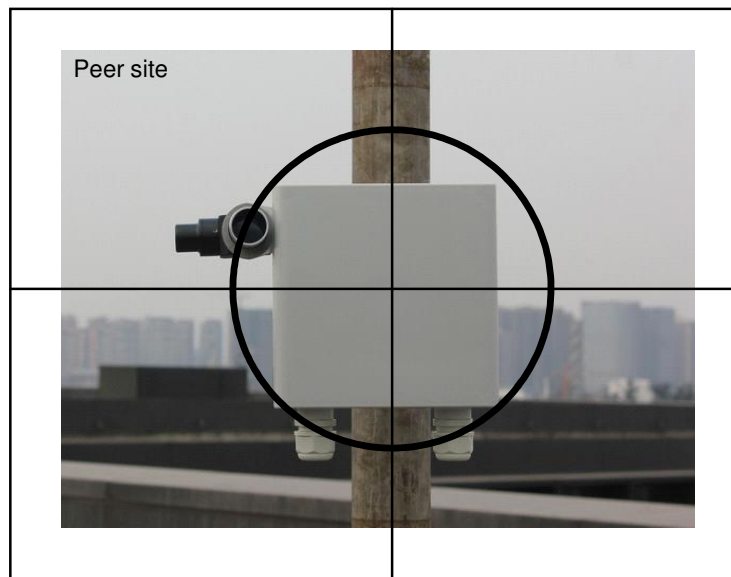

4 Tighten the azimuth and elevation adjustment nuts.

5 Align the peer RTN 360 with the local RTN 360 in the same way.

6 Remove the alignment scope.

NOTE

To adjust the azimuth and elevation of an RTN 360, rotate the azimuth and elevation adjustment nuts. Do not attempt to turn the device or mounting kits.

NOTE

If the azimuth adjustment is insufficient to align the RTN 360 with its peer, loosen the hose clamp, re-position the RTN 360, and then fasten the hose clamp.

Powering On an RTN 360

CAUTION

- After unpacking an RTN 360, power it on within 24 hours.
- Do not power off an RTN 360 for more than 24 hours during maintenance.

NOTE

- Ensure that the Dock is powered on and works properly.
- On an RTN 360, only port P&E supports power over Ethernet.

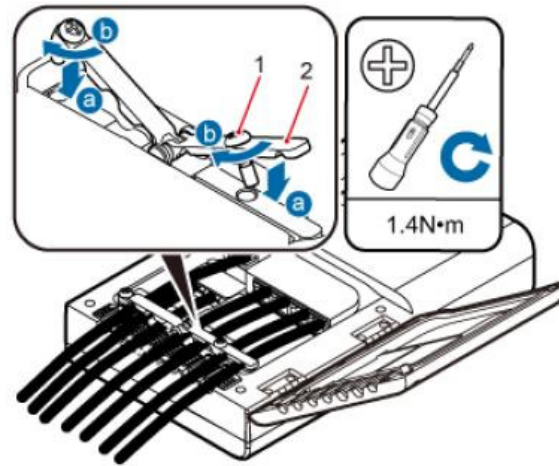

Use clips to fix any indoor sections of the outdoor network cables that connect to ports WAN, LAN0, and LAN1 on the Dock, and remove the plugs in the cable trough.

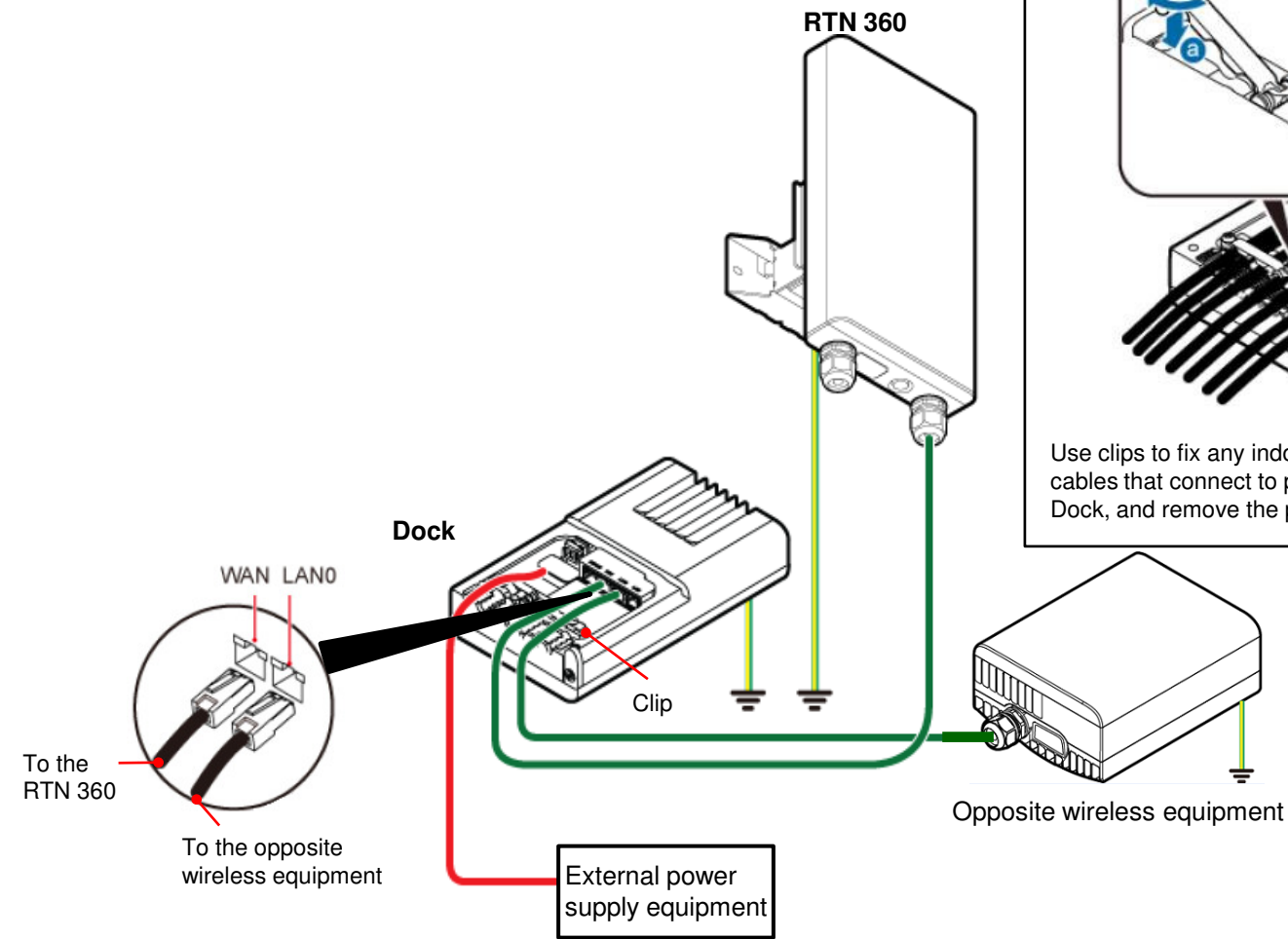

If one Dock supplies power to only one RTN 360, connect the outdoor network cable that connects to port P&E on the RTN 360 to port WAN on the Dock.

When an RTN 360 is running properly, its indicators should be in the following states:

STAT: is steady green.

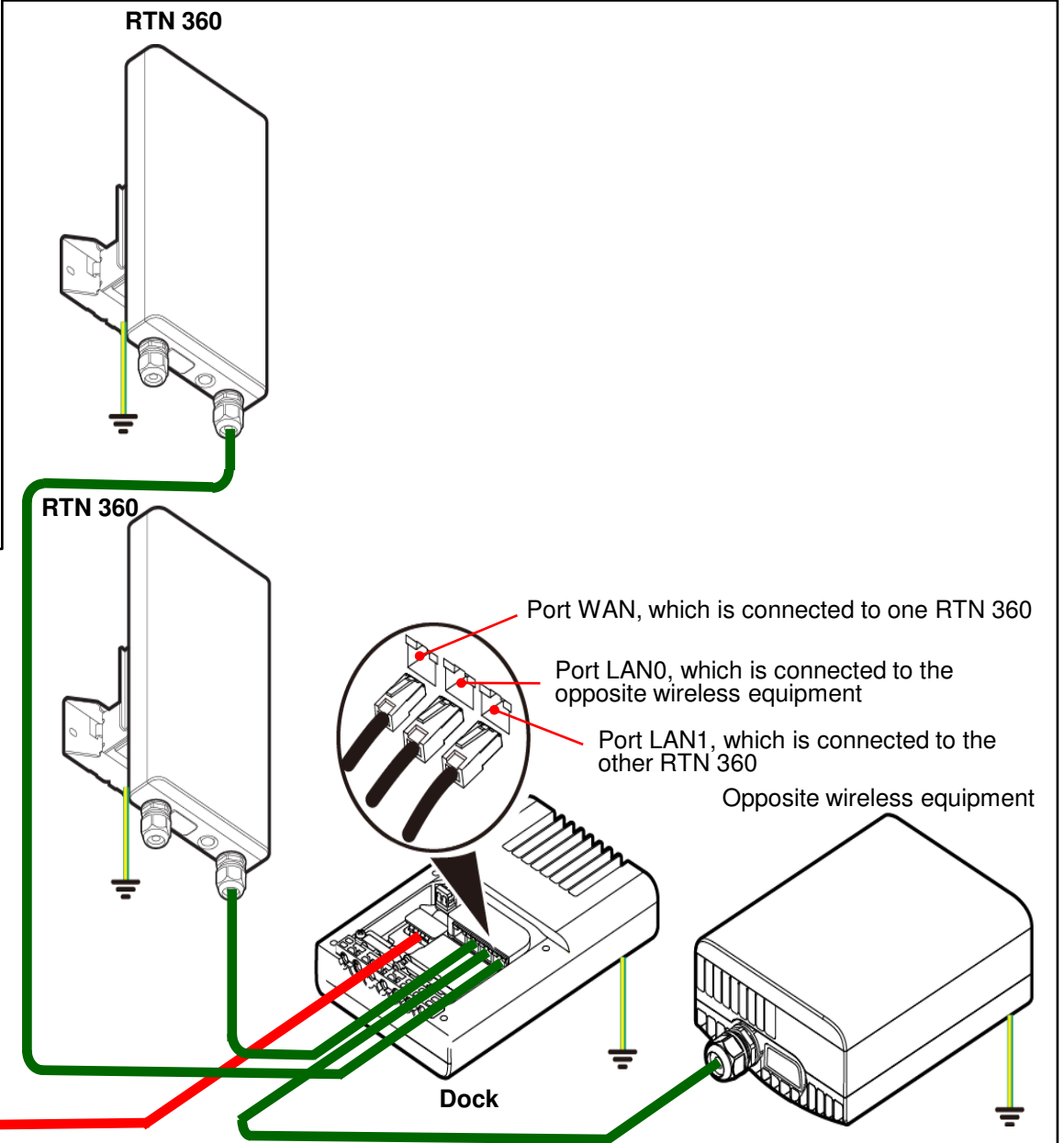

If one Dock supplies power to two RTN 360s, connect the outdoor network cable that connects to port P&E on one RTN 360 to port WAN on the Dock, and the outdoor network cable that connects to port P&E on the other RTN 360 to port LAN1 on the Dock.

References for Installation

Loading Configuration Data and Measuring the RSL



Open the maintenance compartment.



Load configuration data.



Web LCT



USB flash drive



Measure the RSL.



RSL tester



Close the maintenance compartment.

NOTE

If a Wi-Fi module is installed at the USB port, you can determine whether the Wi-Fi module is working properly by enabling it to search for the SSID of an NE in the wireless LAN. If the SSID can be searched out, the Wi-Fi module is working properly. If the SSID cannot be searched out, open the maintenance compartment and view the Wi-Fi module indicator. If the indicator is steady red, replace the Wi-Fi module.

NOTE

If the RSL is lower than the required value, re-align the RTN 360 pair.

Verifying the Installation

- 1 Verify that RTN 360s are installed in planned locations and sufficient space is reserved for maintenance.
- 2 Verify that RTN 360s are securely installed by turning the boxes gently (in both the horizontal and vertical directions).
- 3 Verify that OT terminals of PGND cables are tightly crimped and PGND cables are not damaged or broken.
- 4 Verify that PGND cables are bound separately from other cables.
- 5 Verify that the protection ground of an RTN 360 shares the same ground bar with the lightning protection ground of the building bearing the RTN 360.
- 6 Verify that shielded RJ45 connectors of outdoor network cables are intact and tightly crimped and the cables are not damaged or broken.
- 7 Verify that PG covers are tightly screwed onto the network ports of RTN 360s, unused ports are protected with caps, and removed caps are retained for future use.
- 8 Verify that outdoor network cables are routed along planned paths and bound properly and neatly at equal intervals (about 1 meter), and the excess of each cable tie is cut off without leaving sharp edges.
- 9 Verify that alignment scopes are removed and kept secure.

Relationship between RSSI Port Voltage and Receive Signal Level

Copyright © Huawei Technologies Co., Ltd. 2014. All rights reserved.

Issue: 01

Date: 2014-02-15

RSL(dBm)	-20	-25	-30	-35	-40	-45	-50	-55	-60	-65	-70	-75	-80	-85	-90
RSSI Port Voltage(V)	4.50	4.19	3.89	3.58	3.27	2.96	2.66	2.35	2.04	1.74	1.43	1.12	0.81	0.51	0.20

