

Figure 6-22 Network port signal definition

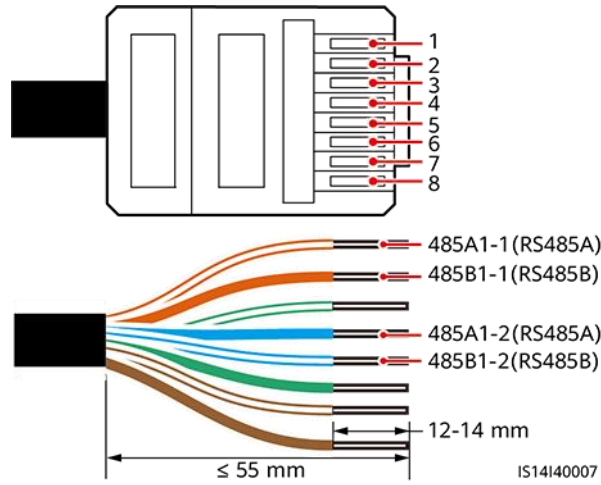

Figure 6-23 Signal cable definitions of the terminal block

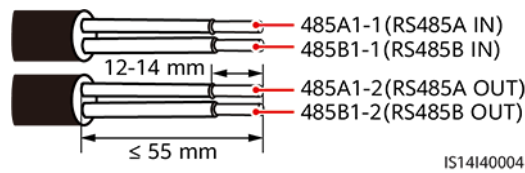
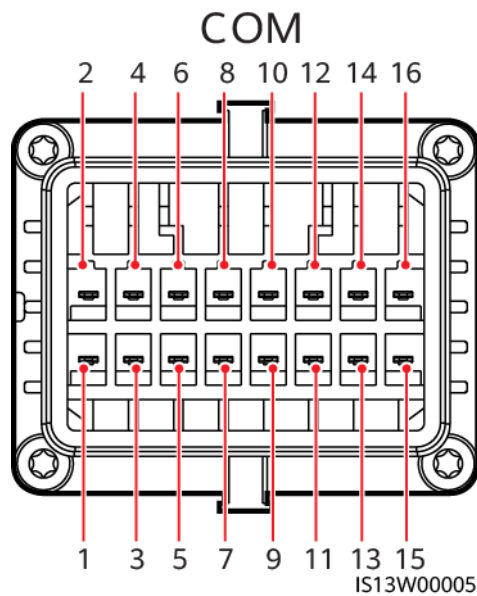

Figure 6-24 COM port



Scenario Where No Signal Cable Is Connected

NOTICE

If no signal cable is connected to the SUN2000, use a waterproof plug to block the cable hole of the signal cable connector and connect the signal cable connector to the communications port on the SUN2000 to improve the waterproof performance.

Figure 6-25 Connecting the signal cable connector

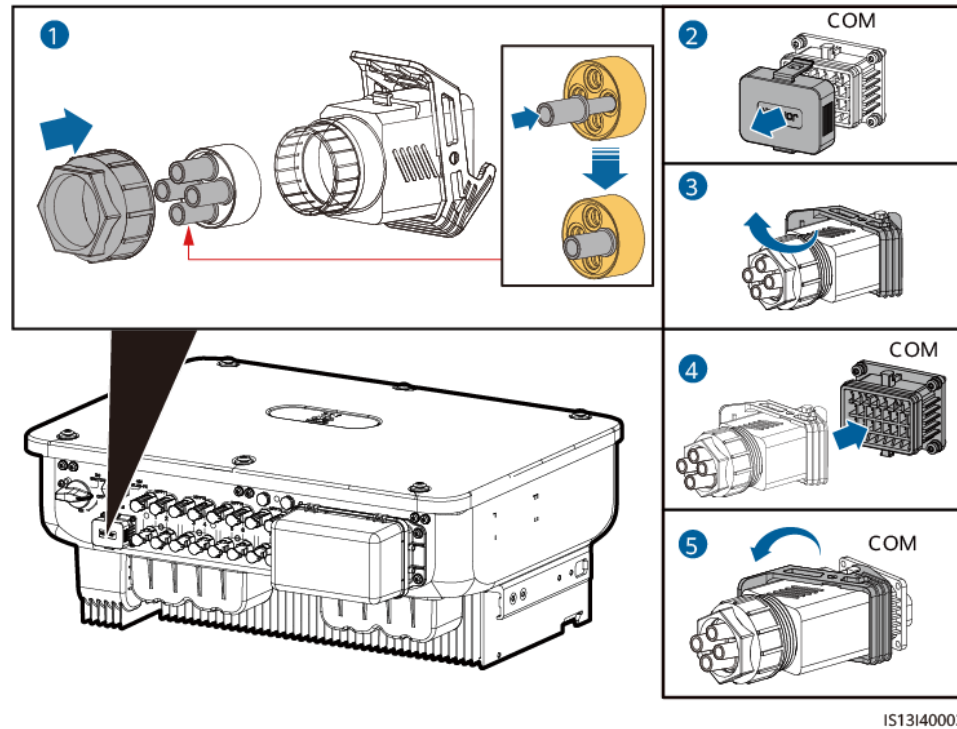

6.3.2.1 Communication Modes

RS485 Communication

Figure 6-26 SmartLogger networking

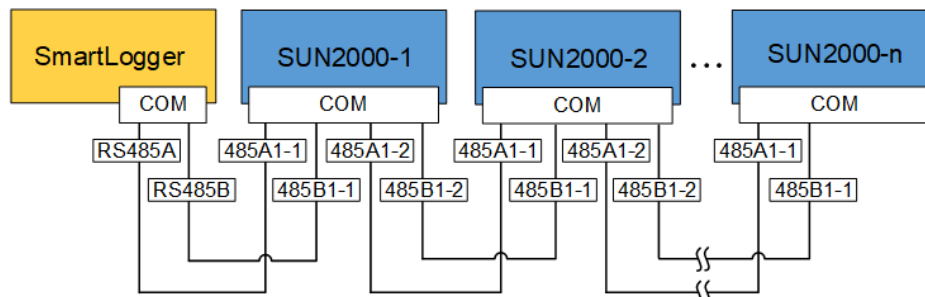

NOTE

It is recommended that the number of SUN2000s connected to each RS485 route be less than 30.

MBUS communication

The MBUS is a communication mode in which communication signals are loaded to power cables through the communications board for transmission.

NOTE

The built-in MBUS module in the SUN2000 does not need to be connected to cables.

6.3.2.2 (Optional) Connecting the RS485 Communications Cable to the SUN2000

Prerequisites

If the signal cables are long enough to connect to the communications port on the SUN2000, you do not need to install an AC adapter box.

Procedure

Step 1 If the original signal cable is connected through RJ45 network ports, cut off the RJ45 connectors.

Figure 6-27 Cut off the RJ45 connectors

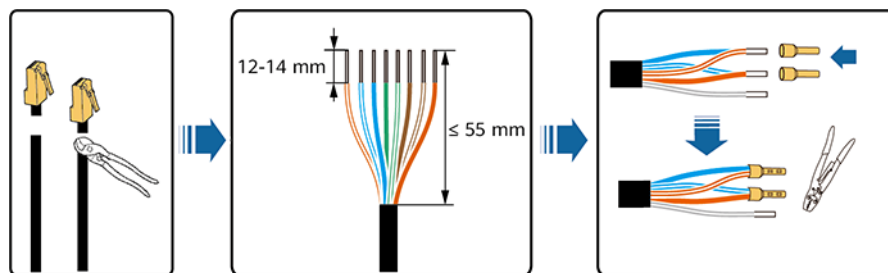

IS14140006

Step 2 Connect the signal cable to the signal cable connector.

Figure 6-28 Connecting the cable

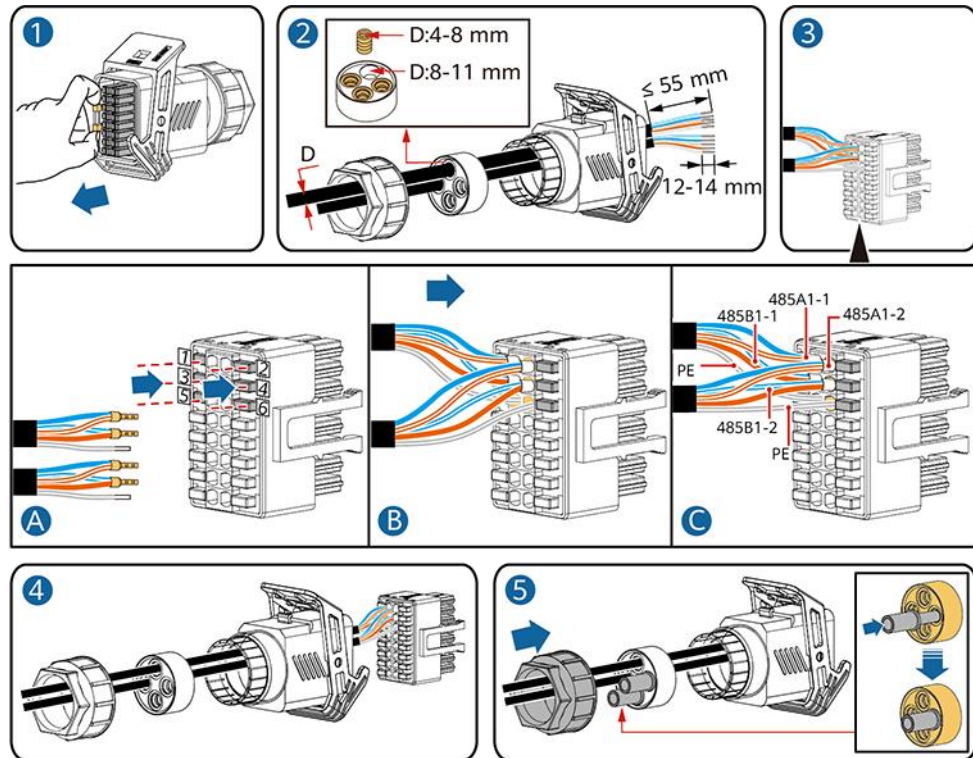

IS14140008

Step 3 Connect the signal cable connector to the COM port.

Figure 6-29 Securing the signal cable connector

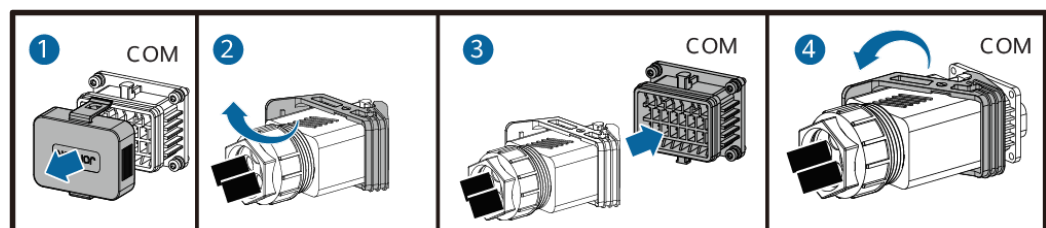

IS13140001

----End

6.3.2.3 (Optional) Connecting the Signal Transfer Cable

Prerequisites

If the signal cables are not long enough to connect to the inverter communications port, connect a signal transfer cable.

Figure 6-30 Terminal block in the AC adapter box

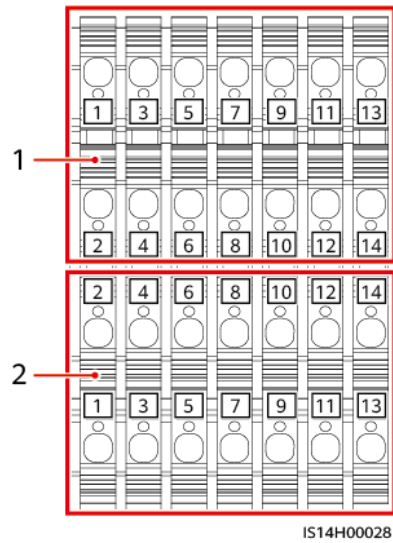

(1) Inverter

(2) Customer

Table 6-1 Signal definitions of the terminal block in the AC adapter box

Port	Reser ved	RS485-1		RS485-2	Ripple Control		
		A1-1	A1-2	A2	DIN1	DIN3	GND
Inverter	-	A1-1	A1-2	A2	DIN1	DIN3	GND
	-	B1-1	B1-2	B2	DIN2	DIN4	-
Customer	-	B-IN	B-OUT	B2	DIN2	DIN4	-
	-	A-IN	A-OUT	A2	DIN1	DIN3	GND

Figure 6-31 Pin definitions

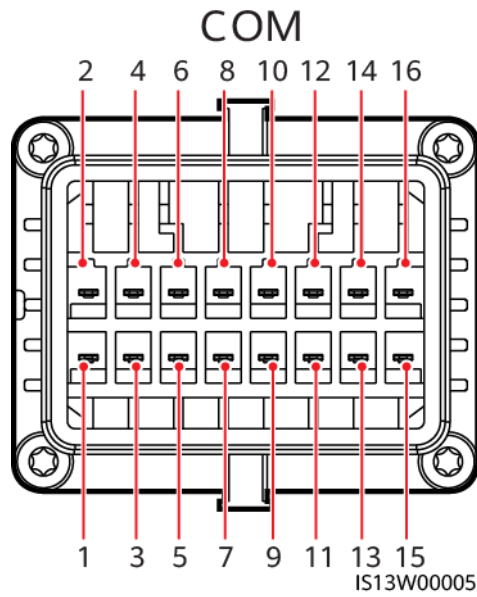

Pin	Definition	Function	Pin	Definition	Function
1	485A1_1	RS485 differential signal +	2	485A1_2	RS485 differential signal +
3	485B1_1	RS485 differential signal -	4	485B1_2	RS485 differential signal -
5	-	-	6	-	-
7	485A2	RS485 differential signal +	8	DIN1	Dry contact for power grid scheduling
9	485B2	RS485 differential signal -	10	DIN2	
11	-	-	12	DIN3	
13	-	-	14	DIN4	
15	-	-	16	GND	

Procedure

- Step 1** Remove the two security Torx screws from the maintenance compartment door using a security Torx wrench.

Figure 6-32 Opening the AC adapter box

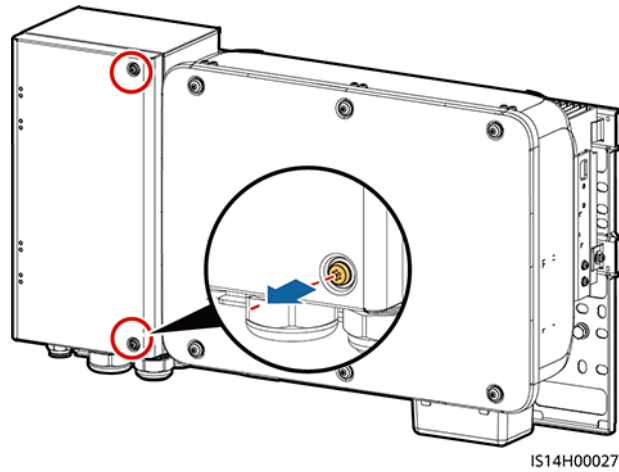

Step 2 Route the signal conversion cable and user-side signal cable through the COM port at the bottom of the AC adapter box.

Figure 6-33 Routing the signal cable

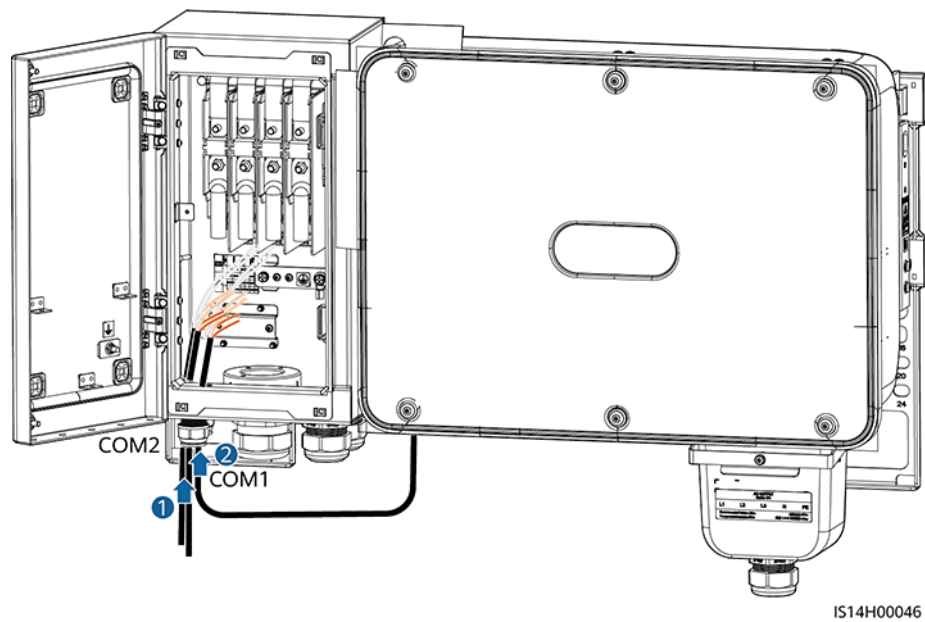

Step 3 Connect one end of the signal conversion cable to the COM port of the inverter.

Figure 6-34 Connecting the signal conversion cable

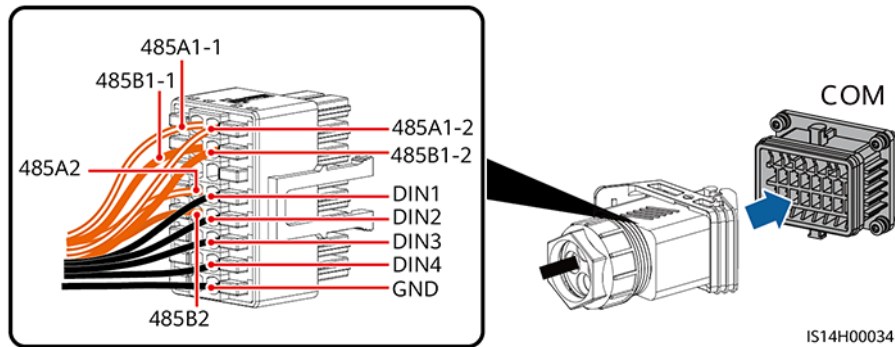

Step 4 Connect the other end of the signal conversion cable to the terminal block.

Figure 6-35 Connecting the signal conversion cable

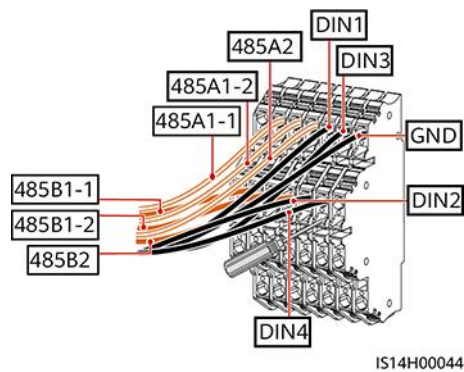

Step 5 Connect the user-side signal cable to the terminal block.

Figure 6-36 Connecting the user-side signal cable

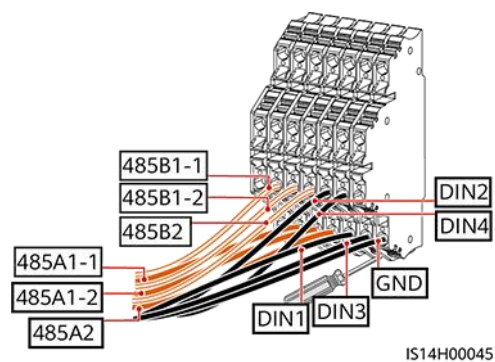

Step 6 Secure the terminal block in the AC adapter box, and connect the PE wires of the signal conversion cable and the user-side signal cable.

Figure 6-37 Secure the terminal block

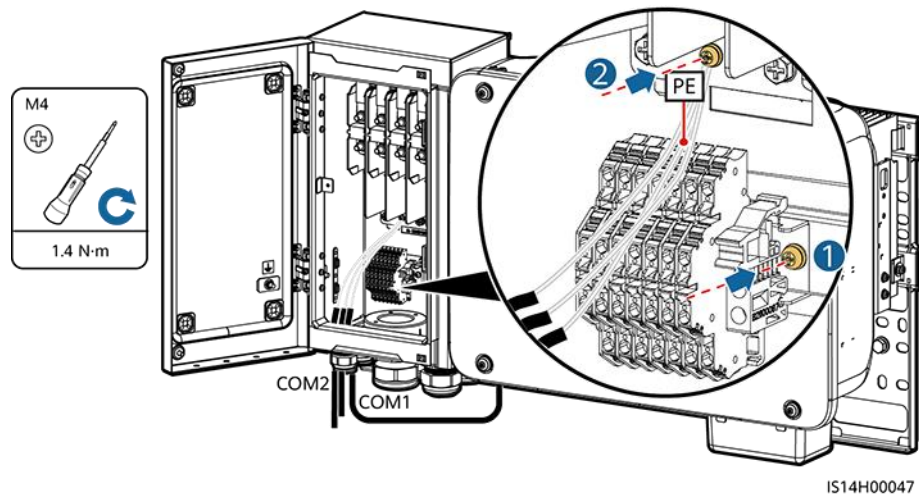

----End

6.3.3 Installing the AC Output Power Cable

Precautions

An AC switch must be installed on the AC side of the SUN2000 to ensure that the SUN2000 can be safely disconnected from the power grid.

WARNING

Do not connect loads between the SUN2000 and the AC switch.

NOTICE

- Use a socket wrench and extension rod to connect the AC power cable. The extension rod must be longer than 150 mm.
 - Do not install third-party devices in the AC connection box.
-

NOTE

There are two rows of AC terminals in the AC adapter box. The lower row is used to connect the AC transfer cable between the AC adapter box and the SUN2000, and the upper row is used to connect the AC output power cable on the user side.

Procedure

Step 1 Connect the AC transfer cable to the AC terminals in the lower row of the AC adapter box.

Figure 6-38 Connecting the AC transfer cable

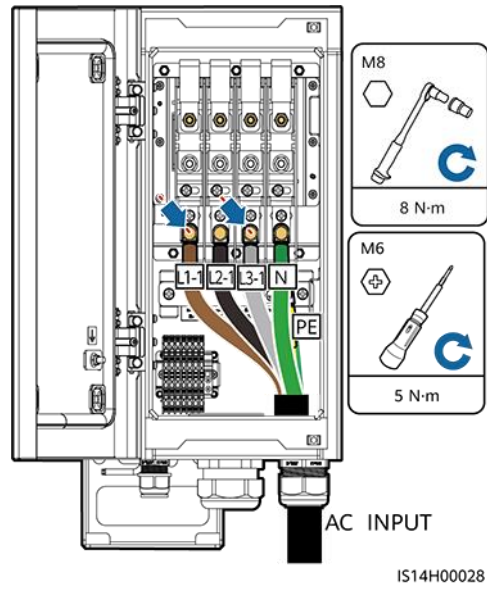

Step 2 Remove the AC terminal box and install partition boards.

Figure 6-39 Removing the AC terminal box

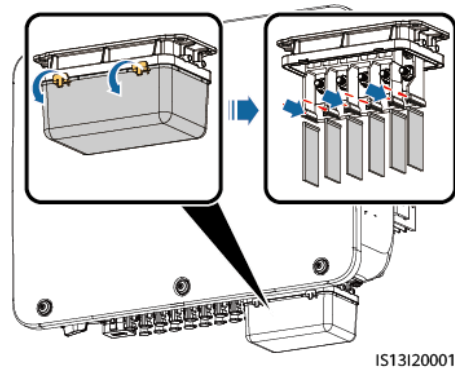

Step 3 Route the AC transfer cable through the AC wiring terminal.

Figure 6-40 Routing the AC power cable

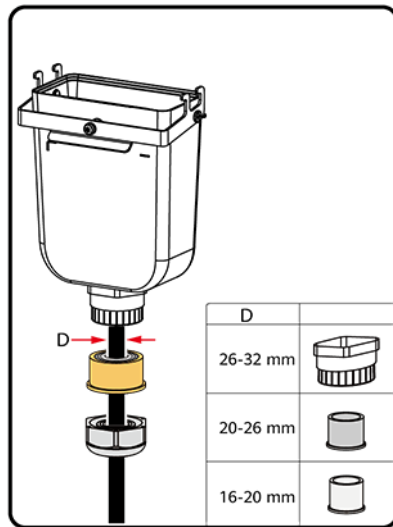

Step 4 Connect the AC transfer cable to the SUN2000.

Figure 6-41 Connecting the AC transfer cable

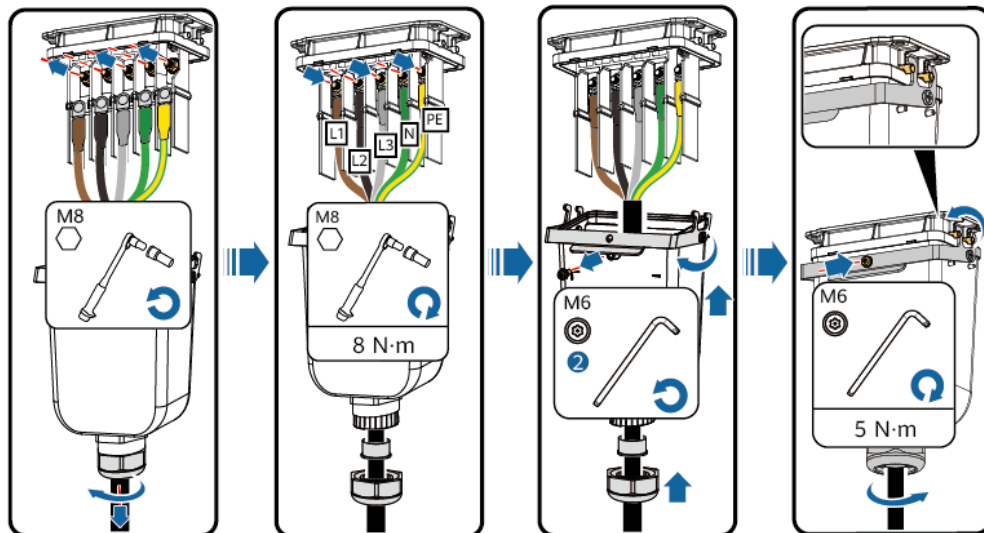

IS13120002

Step 5 Select an appropriate rubber liner based on the cable outer diameter.

Figure 6-42 Selecting an appropriate rubber liner

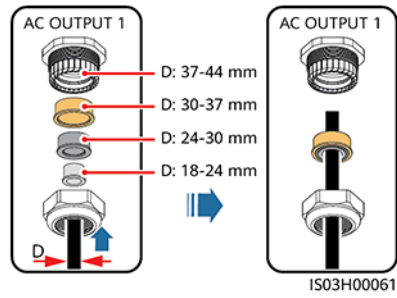

Step 6 Connect the AC output power cable on the user side (using a five-core cable as an example).

Figure 6-43 Connecting the AC power cable

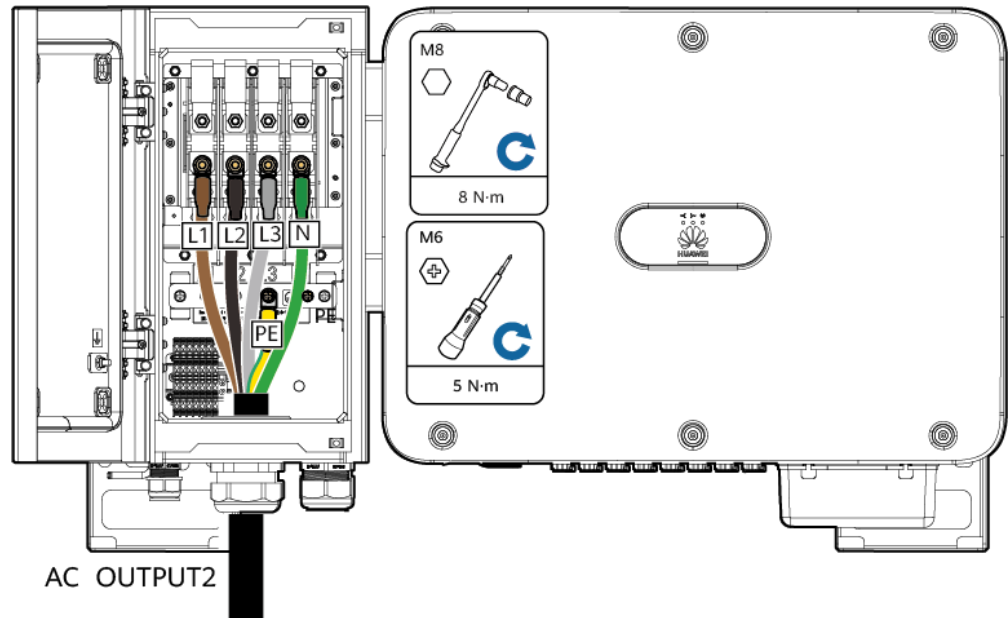

Step 7 Install the AC terminal cover and close the door of the adapter box.

Figure 6-44 Installing the AC terminal cover

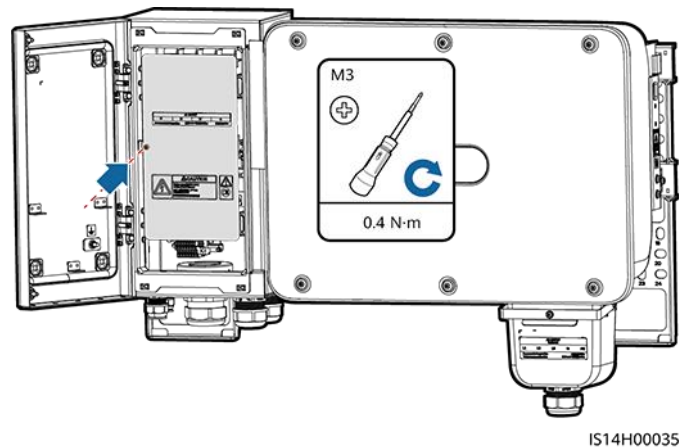

----End

6.3.4 Installing DC Input Power Cables

Precautions

⚠ DANGER

- Before connecting the DC input power cables, ensure that the DC voltage is within the safe range (lower than 60 V DC) and that the DC switch on the SUN2000 is OFF. Failing to do so may result in electric shocks.
- When the SUN2000 is running, it is not allowed to work on the DC input power cables, such as connecting or disconnecting a PV string or a PV module in a PV string. Failing to do so may cause electric shocks.
- If no PV string connects to a DC input terminal of the SUN2000, do not remove the watertight cap from the DC input terminals. Otherwise, the IP rating of the SUN2000 will be affected.

⚠ WARNING

Ensure that the following conditions are met. Otherwise, the SUN2000 may be damaged, or even a fire may occur.

- PV modules connected in series in each PV string are of the same specifications.
- The DC input voltage of the SUN2000 shall not exceed 1100 V DC under any circumstance.
- The polarities of electric connections are correct on the DC input side. The positive and negative terminals of a PV string connect to the corresponding positive and negative DC input terminals of the SUN2000, respectively.
- If the DC input power cables are reversely connected, do not operate the DC switch as well as positive and negative connectors immediately. Wait until the solar irradiance declines at night and the PV string current reduces to below 0.5 A, and then turn off the DC switch and remove the positive and negative connectors. Correct the PV string polarity before reconnecting the PV string to the SUN2000.

NOTICE

- The SUN2000 does not support power supplies other than PV strings. Since the output of the PV string connected to the SUN2000 cannot be grounded, ensure that the PV module output is well insulated to ground.
- During the installation of PV strings and the SUN2000, the positive or negative terminals of PV strings may be short-circuited to ground if the power cables are not properly installed or routed. In this case, an AC or DC short circuit may occur and damage the SUN2000. The caused device damage is not covered under any warranty.
- In the spare part replacement scenario, the DC input power cables can be connected only to PV1–PV6. If the DC input power cables are connected to PV7 or PV8, the inverter data cannot be transmitted to the northbound device.

Figure 6-45 DC input terminals

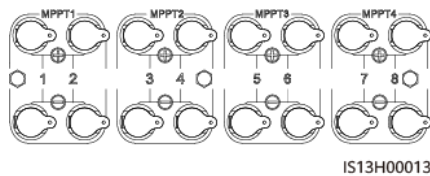

When the DC input is not fully configured, the DC input terminals must meet the following requirements:

1. Evenly distribute the DC input power cables on the four MPPTs and preferentially connect them from MPPT 1 to MPPT 4.
2. Maximize the number of connected MPPTs.

Number of PV Strings	Terminal Selection	Number of PV Strings	Terminal Selection
1	Connects to any route.	2	PV1, PV7
3	PV1, PV3, PV7	4	PV1, PV3, PV5, PV7
5	PV1, PV2, PV3, PV5, PV7	6	PV1, PV2, PV3, PV5, PV7, PV8

Number of PV Strings	Terminal Selection	Number of PV Strings	Terminal Selection
7	PV1, PV2, PV3, PV4, PV5, PV7, PV8	8	PV1, PV2, PV3, PV4, PV5, PV6, PV7, PV8

Procedure

NOTICE

- Before connecting DC input power cables, ensure that the original DC terminals have been cut off. If the original DC connector is directly connected to the SUN2000-(15KTL-50KTL)-M3 series, the inverter may be burnt.
- You are advised to use the PV-CZM-22100 (Staubli) crimping tool and do not use it with the positioning block. Otherwise, the metal terminals may be damaged.
- The PV-MS (Staubli) or PV-MS-HZ (Staubli) open-end wrench is recommended.
- Cables with high rigidity, such as armored cables, are not recommended as DC input power cables, because poor contact may be caused by the bending of the cables.
- Before assembling DC connectors, label the cable polarities correctly to ensure correct cable connections.
- After the positive and negative connectors snap into place, pull the DC input power cables back to ensure that they are connected securely.

CAUTION

Use the positive and negative Staubli MC4 metal terminals and DC connectors delivered with the SUN2000. Using incompatible positive and negative metal terminals and DC connectors may result in serious consequences. The caused device damage is not covered under any warranty or service agreement.

Step 1 Cut off the original DC terminals.

Figure 6-46 Cut off the original DC terminals

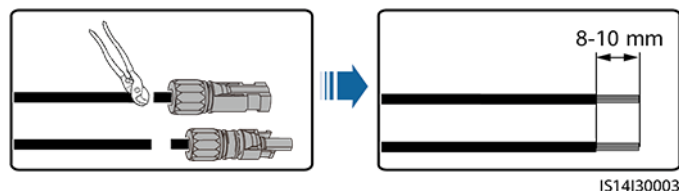

Step 2 Connect the DC power cables.

Figure 6-47 Connecting DC power cables

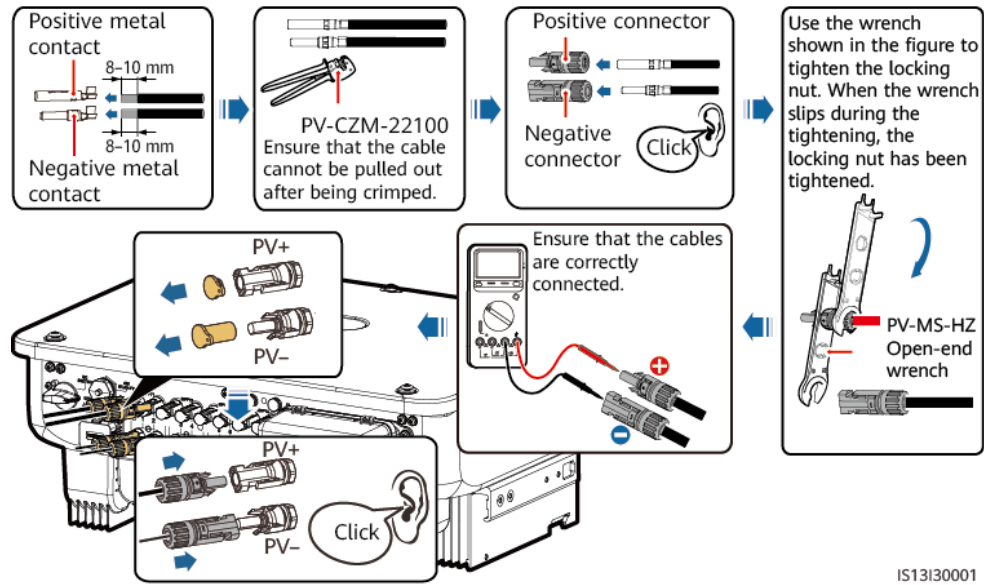

IS13130001

NOTE

If the original DC input power cables are not long enough, use the DC input extension cables delivered with the package.

Figure 6-48 Connecting the DC input extension cable

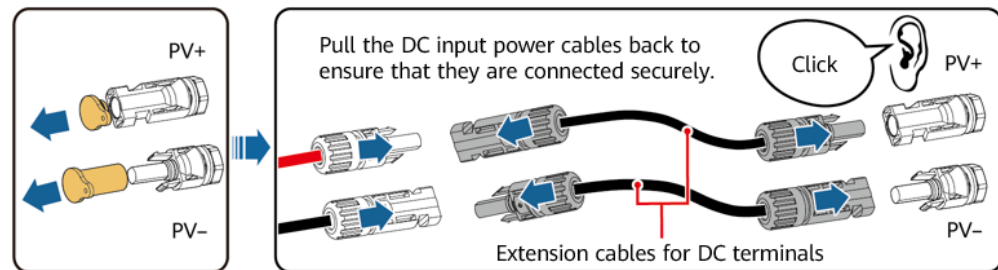

IS10130005

----End

6.3.5 (Optional) Installing the WLAN-FE Smart Dongle

Procedure

If the original SUN2000 uses the FE communication mode, you need to install the WLAN-FE Smart Dongle for the SUN2000 connected to the monitoring device after the replacement. Use the RS485 communication mode for other SUN2000s.

Figure 6-49 Networking diagram before the replacement

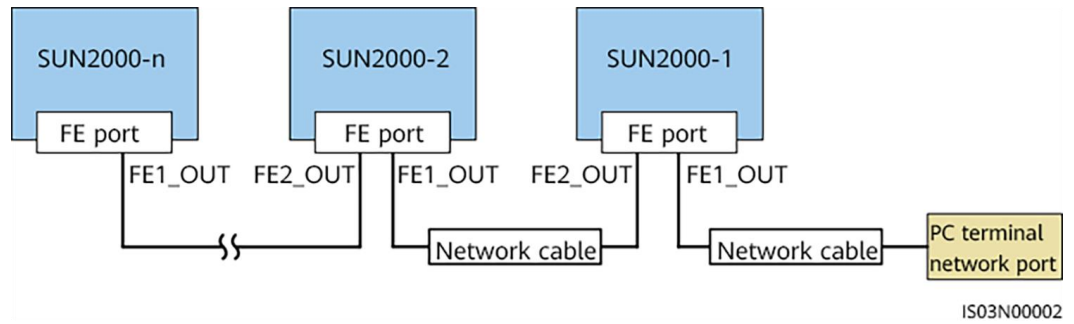
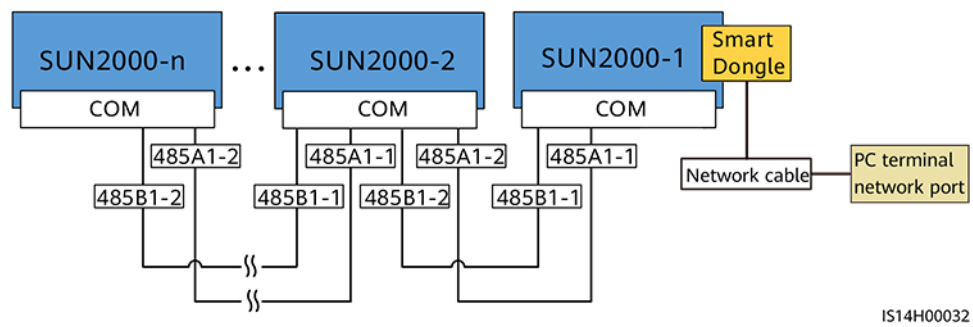
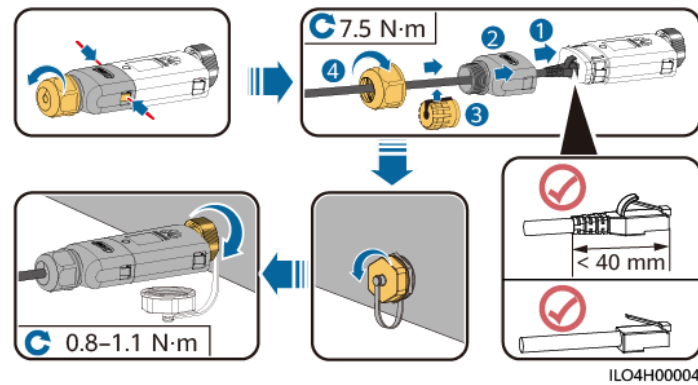

Figure 6-50 Networking diagram after the replacement



Step 1 Install the WLAN-FE Smart Dongle.

Figure 6-51 Installing the WLAN-FE Smart Dongle



NOTICE

- The WLAN-FE Smart Dongle is not provided in standard configuration.
- Install the network cable with before installing the Smart Dongle on the SUN2000.

 **NOTE**

For details about how to use the WLAN-FE Smart Dongle SDongleA-05, see [SDongleA-05 Quick Guide \(WLAN-FE\)](#). The quick guide is delivered with the Smart Dongle. You can also scan the QR code to obtain the documentation.



----End

7 Commissioning

7.1 Checking Before Power-On

Table 7-1 Checklist

No.	Check Item	Acceptance Criteria
1	SUN2000 installation	The SUN2000 is installed correctly and securely.
2	Smart Dongle	The Smart Dongle is installed correctly and securely.
3	Cable routing	The cables are routed properly as required by the customer.
4	Cable ties	Cable ties are evenly distributed and no burr exists.
5	Reliable grounding	The PE cable is connected correctly and securely.
6	Switch	DC switches and all the switches connecting to the SUN2000 are OFF.
7	Cable connection	The AC output power cable, and DC input power cables are connected correctly and securely.
8	Unused terminals and ports	Unused terminals and ports are locked by watertight caps.
9	Installation environment	The installation space is proper, and the installation environment is clean and tidy.

7.2 System Power-On

Prerequisites

NOTICE

- Before turning on the AC switch between the SUN2000 and the power grid, check that the AC voltage is within the specified range using a multimeter.
- If the DC power supply is connected but the AC power supply is disconnected, the SUN2000 will report a **Grid Loss** alarm. The SUN2000 can start properly only after the power grid recovers.

Procedure

Step 1 Turn on the AC switch between the SUN2000 and the power grid.

Step 2 (Optional) Remove the locking screw beside the DC switch.

Figure 7-1 Removing the locking screw beside the DC switch

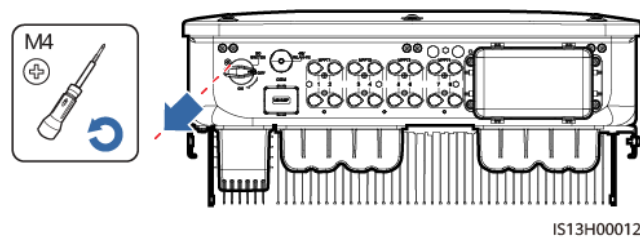

Step 3 Turn on the DC switch at the bottom of the SUN2000.

Step 4 Observe the LED indicators to check the operating status of the SUN2000.

Table 7-2 Indicator description

Category	Status		Description
Running indicator  LED1 LED2	LED1	LED2	–
	Steady green	Steady green	The SUN2000 is operating in grid-tied mode.
	Blinking green slowly (on for 1s and off for 1s)	Off	The DC is on and the AC is off.
	Blinking green slowly (on for 1s and off for 1s)	Blinking green slowly (on for 1s and off for 1s)	Both the DC and AC are on, and the SUN2000 is not supplying power to the power grid.

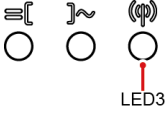
Category	Status		Description
	Off	Blinking green slowly	The DC is off and the AC is on.
	Off	Off	Both the DC and AC are off.
	Blinking red fast (on for 0.2s and off for 0.2s)	–	DC environment alarm
	–	Blinking red fast (on for 0.2s and off for 0.2s)	AC environment alarm
	Steady red	Steady red	Faulty
Communications indicator 	LED3		–
	Blinking green fast (on for 0.2s and then off for 0.2s)		Communication is in progress.
	Blinking green slowly (on for 1s and off for 1s)		A mobile phone is connected.
	Off		No communication
Note: If LED1, LED2, and LED3 are steady red, the SUN2000 is faulty and needs to be replaced.			

----End

8 Human-Machine Interaction

8.1 Setting Parameters for Replacing a SUN2000

NOTE

Access the HUAWEI AppGallery (<http://appstore.huawei.com>), search for **SUN2000**, and download the app installation package. You can also scan the QR code below to download the app. You are advised to use a browser to scan the QR code.



NOTICE

- The screenshots are for reference only. The actual screens may vary.
- Obtain the initial password for connecting to the SUN2000 WLAN from the label on the side of the SUN2000.
- Set the password upon the first login. You are advised to change the password periodically. After changing the password, remember the new password to ensure account security. Not changing the initial password may cause password disclosure. A password left unchanged for a long period of time may be stolen or cracked. If a password is lost, devices cannot be accessed. In these cases, the user is liable for any loss caused to the PV plant.
- Set the correct grid code based on the application area and scenario of the SUN2000.

Step 1 Connect to the WLAN of the SUN2000 and log in as user **installer**.

Figure 8-1 Login

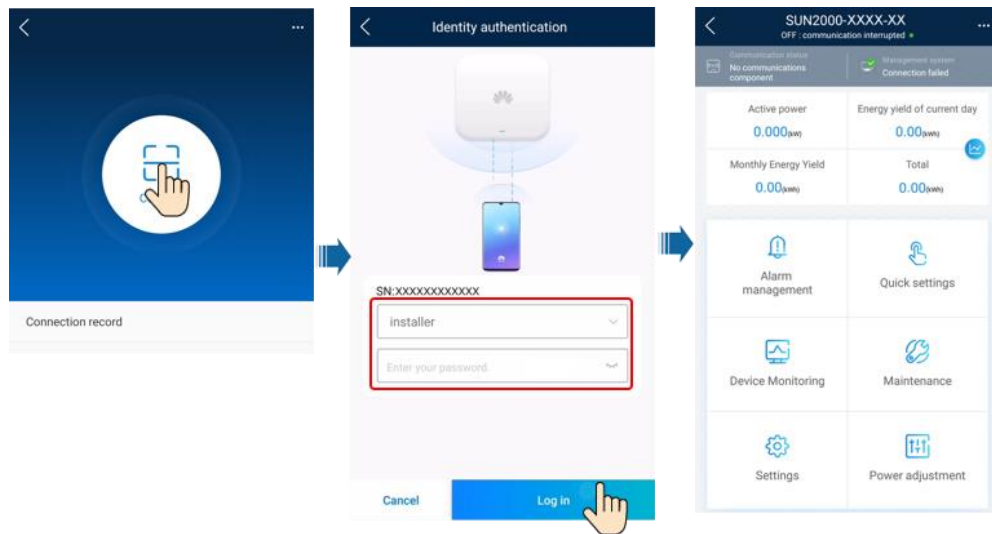

NOTE

At the first login, the **Quick settings** screen is displayed by default. Exit the quick settings.

Step 2 Choose **Maintenance > Device replacement**, select a device replacement type, and set related parameters.

Figure 8-2 Replacement

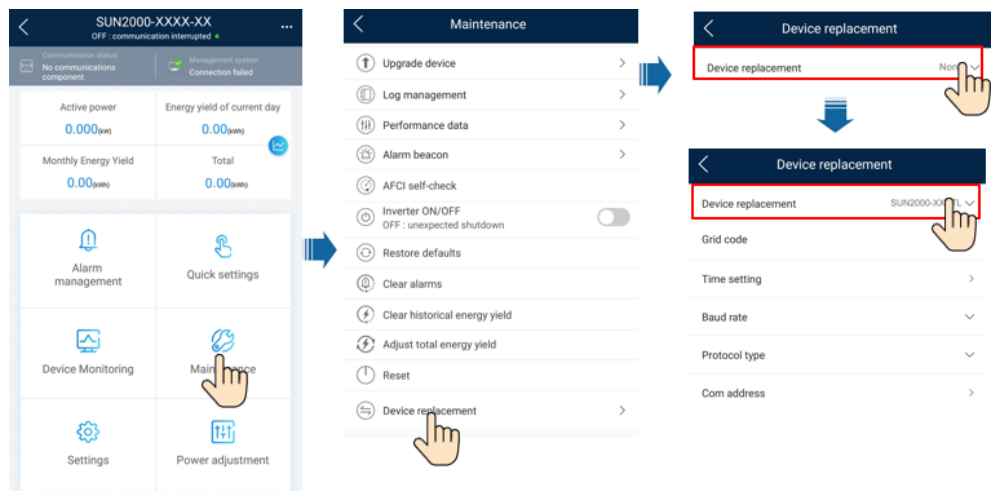

NOTE

You need to set **Device replacement** parameter only when the SUN2000 V100, SUN2000 V200R001, or SUN2000 V200R002 inverters are replaced with SUN2000-(15KTL-50KTL)-M3 series inverters. You do not need to set the parameter when the inverters are replaced with inverters of the same version.

Step 3 (Optional) If other parameters need to be set, tap **Settings** on the home screen and set other parameters.

----End

8.2 SmartLogger Networking Scenario

For details, see *PV Plants Connecting to Huawei Hosting Cloud Quick Guide (Inverters + SmartLogger3000)*, *PV Plants Connecting to SmartPVMS Quick Guide (Inverters + SmartLogger3000 + RS485 Networking)* and *PV Plants Connecting to SmartPVMS Quick Guide (Inverters + SmartLogger3000 + MBUS Networking)*.

9 Maintenance

9.1 System Power-Off

Precautions

WARNING

After the SUN2000 powers off, the remaining electricity and heat may still cause electric shocks and body burns. Therefore, put on protective gloves and begin operating the SUN2000 five minutes after the power-off.

Procedure

- Step 1** Send a shutdown command on the app.
- Step 2** Turn off the AC switch between the SUN2000 and the power grid.
- Step 3** Turn off the DC switch at the bottom of the SUN2000.
- Step 4** (Optional) Install the locking screw for the DC switch.

Figure 9-1 Installing the locking screw for the DC switch

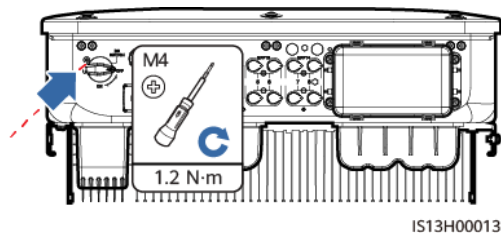

- Step 5** Turn on the DC switch between the PV string and the SUN2000 if there is any.

----End

9.2 Routine Maintenance

To ensure that the SUN2000 can operate properly for a long term, you are advised to perform routine maintenance on it as described in this chapter.

CAUTION

Before cleaning the system, connecting cables, and ensuring the grounding reliability, power off the system.

Table 9-1 Maintenance checklist

Check Item	Check Method	Maintenance Interval
System cleanliness	Check periodically that the heat sinks are free from obstacles and dust.	Once every 6 to 12 months
System operating status	<ul style="list-style-type: none">• Check that the SUN2000 is not damaged or deformed.• Check that the SUN2000 operates with no abnormal sound.• Check that all SUN2000 parameters are correctly set during operation.	Once every 6 months
Electrical connection	<ul style="list-style-type: none">• Check that cables are secured.• Check that cables are intact, and that in particular, the parts touching the metallic surface are not scratched.	The first inspection is 6 months after the initial commissioning. From then on, the interval can be 6 to 12 months.
Grounding reliability	Check that ground cables are securely connected.	The first inspection is 6 months after the initial commissioning. From then on, the interval can be 6 to 12 months.
Air tightness	Check that all terminals and ports are properly sealed.	Once a year

9.3 Troubleshooting

Alarm severities are defined as follows:

- Major: The inverter is faulty. As a result, the output power decreases or the grid-tied power generation is stopped.
- Minor: Some components are faulty without affecting the grid-tied power generation.
- Warning: The inverter works properly. The output power decreases or some authorization functions fail due to external factors.

Table 9-2 Common fault alarm list

ID	Name	Severity	Cause	Solution
103	High DC input voltage	Major	<p>The PV array is not properly configured. Excessive PV modules are connected in series to the PV string, and therefore the PV string open-circuit voltage exceeds the maximum inverter operating voltage.</p> <ul style="list-style-type: none"> • Cause ID 1: PV strings 1 and 2 • Cause ID 2: PV strings 3 and 4 • Cause ID 3: PV strings 5 and 6 • Cause ID 4: PV strings 7 and 8 	<p>Reduce the number of PV modules connected in series to the PV string until the PV string open-circuit voltage is less than or equal to the maximum inverter operating voltage. After the PV string configuration is corrected, the alarm disappears.</p>
106~113	Abnormal string 1 to Abnormal string 8	Warning	<p>Cause ID = 1</p> <ul style="list-style-type: none"> • The PV string is shaded for a long time. • The PV string is aged. 	<ol style="list-style-type: none"> 1. Check whether the PV string current is obviously lower than the currents of other PV strings. 2. If the PV string current is obviously low, check whether the PV string is shaded. 3. If the PV string surface is clean and not shaded, check whether PV modules are damaged.
120~127	String 1 reversed to String 8 reversed	<ul style="list-style-type: none"> • Cause ID = 1: Major • Cause ID = 2: Warning 	<ul style="list-style-type: none"> • Cause ID = 1 The PV string polarity is reversed. • Cause ID = 2 The number of PV modules connected in series to the PV string is insufficient. As a result, the terminal voltage is lower than that of other strings. 	<ul style="list-style-type: none"> • Cause ID = 1 Check whether the PV string is reversely connected to the inverter. If yes, wait until the solar irradiance declines at night and the PV string current drops to below 0.5 A. Then, turn off the two DC switches and correct the PV string connection. • Cause ID = 2 Check whether the number of PV modules connected in series to the PV string is less than that of other PV strings. If yes, adjust the number of PV modules.
200	Abnormal DC circuit	Major	<p>Abnormal external conditions trigger the protection for the DC circuit inside the inverter. The possible causes are as follows:</p> <ul style="list-style-type: none"> • Cause ID = 3 	<ul style="list-style-type: none"> • Cause ID = 3/10/11 <ol style="list-style-type: none"> 1. The inverter monitors its external operating conditions in real time and automatically recovers after the fault is rectified.

ID	Name	Severity	Cause	Solution
			<p>The inverter input is disconnected accidentally, or the PV string output power changes sharply because the PV string is shaded.</p> <ul style="list-style-type: none"> • Cause ID = 10 The three phases of the power grid are seriously unbalanced, which triggers the protection for the internal control circuit of the inverter. • Cause ID = 11 The power grid voltage changes sharply and the inverter input power fails to discharge in a short time, which increases the internal voltage and triggers protection. • Cause ID = 12/15 An unrecoverable fault occurs on a circuit inside the inverter. • Cause ID = 16 The voltage between the PV string and the ground is abnormal, and there is a risk of power degradation. 	<p>2. If the alarm persists, contact Huawei technical support.</p> <ul style="list-style-type: none"> • Cause ID = 12/15 Turn off the AC output switch and DC input switch, and then turn them on after 5 minutes. If the alarm persists, contact Huawei technical support. <p>NOTE Cause ID = 12: Perform the preceding operations when the PV string current is less than 1 A.</p> <ul style="list-style-type: none"> • Cause ID = 16 <ol style="list-style-type: none"> 1. If there is no PID module in the system, set PID protection at night and Night-time reactive power output to Disable for the inverter over the SmartLogger or app. 2. If there is a PID module in the system, check whether the device is abnormal. If yes, rectify the fault. 3. Check whether PID compensation direction of the inverter and PV module compensation voltage direction of the PID module are correctly set based on the PV module model. If not, reset them on the SmartLogger or app. 4. If the alarm persists, contact your dealer or Huawei technical support.
202	Abnormal invert circuit	Major	<p>Abnormal external conditions trigger the protection for the inverter circuit inside the inverter. The possible causes are as follows:</p> <ul style="list-style-type: none"> • Cause ID = 13 The power grid voltage drops dramatically or the power grid is short-circuited. As a result, the internal voltage detection circuit in the inverter is damaged. 	<ul style="list-style-type: none"> • Cause ID = 13/14/16 <ol style="list-style-type: none"> 1. The inverter monitors its external operating conditions in real time and automatically recovers after the fault is rectified. 2. If the alarm persists, contact Huawei technical support. • Cause ID = 20 <ol style="list-style-type: none"> 1. Check whether the inverter output power cable is short-circuited.

ID	Name	Severity	Cause	Solution
			<ul style="list-style-type: none"> • Cause ID = 14 The power grid voltage drops dramatically or the power grid is short-circuited. As a result, the inverter transient output current exceeds the upper threshold, and protection is triggered. • Cause ID = 16 The DC component in the power grid current exceeds the upper threshold. • Cause ID = 20 The inverter output is short-circuited. As a result, the output current surges to a value above the upper threshold, and the inverter protection is triggered. 	<ol style="list-style-type: none"> 2. If the alarm persists, contact Huawei technical support.
301	Abnormal grid voltage	Major	<p>The power grid voltage is outside the acceptable range. The possible causes are as follows:</p> <ul style="list-style-type: none"> • Cause ID = 4 The power grid voltage is below the lower threshold. • Cause ID = 16 The power grid voltage exceeds the upper threshold. • Cause ID = 19 The power grid voltage has exceeded the upper threshold for 10 minutes. • Cause ID = 26 The power grid voltage exceeds the upper threshold. • Cause ID = 28 The three phases of the power grid differ greatly in voltage. • Cause ID = 29 <ol style="list-style-type: none"> 1. Power grid outage occurs. 2. The AC circuit is 	<ul style="list-style-type: none"> • Cause ID = 4 <ol style="list-style-type: none"> 1. If the alarm occurs occasionally, the power grid may be abnormal temporarily. The inverter automatically recovers after detecting that the power grid becomes normal. 2. If the alarm persists, check whether the power grid voltage is within the acceptable range. If not, contact the local power operator. If yes, log in to the app, SmartLogger, or NMS to change the power grid overvoltage and undervoltage protection thresholds with the consent of the local power operator. 3. If the alarm persists for a long time, check the AC circuit breaker and AC output power cable. • Cause ID = 16/19/26 <ol style="list-style-type: none"> 1. If the voltage at the grid connection point is too high, contact the local power operator.

ID	Name	Severity	Cause	Solution
			<p>disconnected or the AC switch is off.</p> <ul style="list-style-type: none"> • Cause ID = 31/32/33 The impedance of the output phase wire A (cause ID = 31)/B (cause ID = 32)/C (cause ID = 33) to the PE cable is low or the wire is short-circuited. 	<ol style="list-style-type: none"> 2. If you have confirmed that the voltage at the grid connection point exceeds the upper threshold and obtained consent from the local power operator, modify the overvoltage protection thresholds. 3. Check whether the peak grid voltage exceeds the upper threshold. <ul style="list-style-type: none"> • Cause ID = 28 <ol style="list-style-type: none"> 1. If the exception is caused by an external fault, the inverter automatically recovers after the fault is rectified. 2. If the alarm persists and affects the energy yield of the PV plant, contact the local power operator. • Cause ID = 29 <ol style="list-style-type: none"> 1. Check the AC voltage. 2. Check whether the AC circuit is disconnected or the AC switch is off. • Cause ID = 31/32/33 Check the impedance of the output phase wire A (cause ID = 31)/B (cause ID = 32)/C (cause ID = 33) to the PE cable, locate the position with lower impedance, resolve the issue.
305	Abnormal grid frequency	Major	<ul style="list-style-type: none"> • Cause ID = 2 The actual power grid frequency is higher than the requirements for the local power grid code. • Cause ID = 4 The actual power grid frequency is lower than the requirements for the local power grid code. • Cause ID = 5 The actual change rate of the power grid frequency does not meet the requirements for the local power grid code. 	<ul style="list-style-type: none"> • Cause ID = 2/4 <ol style="list-style-type: none"> 1. If the alarm occurs occasionally, the power grid may be abnormal temporarily. The inverter automatically recovers after detecting that the power grid becomes normal. 2. If the alarm persists, check whether the power grid frequency is within the acceptable range. If not, contact the local power operator. If yes, log in to the app, SmartLogger, or NMS to change the power grid overfrequency and

ID	Name	Severity	Cause	Solution
				<p>underfrequency protection thresholds with the consent of the local power operator.</p> <ul style="list-style-type: none"> • Cause ID = 5 <ol style="list-style-type: none"> 1. If the alarm occurs occasionally, the power grid may be abnormal temporarily. The inverter automatically recovers after detecting that the power grid becomes normal. 2. If the alarm persists, check whether the power grid frequency is within the acceptable range. If not, contact the local power operator.
313	Low insulation resistance	Major	<p>Cause ID = 1</p> <ul style="list-style-type: none"> • The PV array is short-circuited with PE. • The PV string is installed in a moist environment for a long time. 	<ol style="list-style-type: none"> 1. Check the impedance between the PV string and the PE cable. If a short circuit occurs, rectify the fault. 2. If you have confirmed that the impedance is less than the default value in a cloudy or rainy environment, log in to the app, SmartLogger, or NMS and set Insulation resistance protection threshold.
318	Abnormal residual current	Major	<p>Cause ID = 1</p> <p>The insulation resistance against the PE cable at the input side decreases when the inverter is operating, which causes an excessively high residual current.</p>	<ol style="list-style-type: none"> 1. If the alarm occurs accidentally, the external power cable may be abnormal temporarily. The inverter automatically recovers after the fault is rectified. 2. If the alarm persists or lasts a long time, check whether the impedance between the PV string and ground is too low.
321	Cabinet overtemperature	Major	<p>Cause ID = 1</p> <ul style="list-style-type: none"> • The inverter is installed in a place with poor ventilation. • The ambient temperature exceeds the upper threshold. • The internal fan is faulty. 	<ol style="list-style-type: none"> 1. Check the ventilation and ambient temperature at the inverter installation position. 2. If the ventilation is poor or the ambient temperature exceeds the upper threshold, improve the ventilation and heat dissipation. 3. If the ventilation and ambient temperature are normal, contact Huawei technical support.
326	Abnormal grounding	Major	<p>Cause ID = 1</p> <ul style="list-style-type: none"> • The neutral wire or PE 	<ol style="list-style-type: none"> 1. Check whether the neutral wire and PE cable of the inverter are properly connected.

ID	Name	Severity	Cause	Solution
			<p>cable of the inverter is not connected.</p> <ul style="list-style-type: none"> The output side of the inverter does not connect to an isolation transformer when the PV strings are grounded. 	<ol style="list-style-type: none"> If the PV string output is grounded, check whether the output side of the inverter connects to an isolation transformer.
400	System fault	Major	<p>Cause ID = 1/3/21/23/27</p> <p>An unrecoverable fault occurs on a circuit inside the inverter.</p>	<p>Turn off the AC output switch and DC input switch, and then turn them on after 5 minutes. If the alarm persists, contact Huawei technical support.</p>
410	Abnormal auxiliary power	Major	<p>Cause ID = 4</p> <p>The sampling control board has an abnormal voltage. The possible causes are as follows:</p> <ul style="list-style-type: none"> The internal power chip of the sampling control board is faulty. The detection circuit is faulty. 	<ol style="list-style-type: none"> When the alarm is generated, the inverter shuts down automatically. After the fault is rectified, the inverter automatically starts. If the alarm persists, contact Huawei technical support.
411	AFCI self-check failure	Major	<p>Cause ID = 1/2/3</p> <p>The AFCI self-check fails.</p>	<ol style="list-style-type: none"> Turn off the AC output switch and DC input switch, and then turn them on after 5 minutes. If the alarm persists, contact Huawei technical support. If you have confirmed that the AFCI function is not required, disable it.
412	DC arc fault	Major	<p>Cause ID = 1/2/3/4</p> <p>The PV string cable is in poor contact or with open circuits.</p>	<p>Check whether the PV string cable is in poor contact or with open circuits. If yes, reconnect the cable.</p>
504	Software version unmatch	Minor	<p>Cause ID = 1/2/3</p> <p>During inverter software upgrade, the version of the software loaded is incorrect.</p>	<p>Check whether you have performed a software upgrade recently. If yes, upgrade the software to the correct version again.</p>
505	Upgrade failed	Major	<p>Cause ID = 1</p> <p>The upgrade is not completed normally.</p>	<p>Perform the upgrade again.</p>
506	License expired	Warning	<p>Cause ID = 1</p> <ul style="list-style-type: none"> The license has entered its grace period. The license is about to expire. 	<ol style="list-style-type: none"> Apply for a new license. Load a new license.

ID	Name	Severity	Cause	Solution
2001	High string input voltage	Major	<p>The PV array is not properly configured. Excessive PV modules are connected in series to the PV string, and therefore the PV string open-circuit voltage exceeds the maximum inverter operating voltage.</p> <ul style="list-style-type: none"> • Cause ID 1: PV strings 1 and 2 • Cause ID 2: PV strings 3 and 4 • Cause ID 3: PV strings 5 and 6 • Cause ID 4: PV strings 7 and 8 	<p>Reduce the number of PV modules connected in series to the PV string until the PV string open-circuit voltage is less than or equal to the maximum inverter operating voltage. After the PV string configuration is corrected, the alarm disappears.</p>
2002	DC arc fault	Major	<p>The PV string power cables arc or are in poor contact.</p> <ul style="list-style-type: none"> • Cause ID 1: PV strings 1 and 2 • Cause ID 2: PV strings 3 and 4 • Cause ID 3: PV strings 5 and 6 • Cause ID 4: PV strings 7 and 8 	<p>Check whether the PV string cables arc or are in poor contact.</p>
2003	DC arc fault	Major	<p>The PV string power cables arc or are in poor contact. Cause ID 1–8: PV strings 1–8</p>	<p>Check whether the PV string cables arc or are in poor contact.</p>
2011	String reverse connection	Major	<p>The PV string polarity is reversed. Cause ID 1–8: PV strings 1–8</p>	<p>Check whether the PV string is reversely connected to the inverter. If yes, wait until the solar irradiance declines at night and the PV string current drops to below 0.5 A. Then, turn off the two DC switches and correct the PV string connection.</p>
2012	String current backfeed	Warning	<p>The number of PV modules connected in series to the PV string is insufficient. As a result, the terminal voltage is lower than that of other strings. Cause ID 1–8: PV strings 1–8</p>	<ol style="list-style-type: none"> 1. Check whether the number of PV modules connected in series to the PV string is less than that of other PV strings. If yes, wait until the PV string current drops below 0.5 A, turn off all DC switches, and adjust the number of PV modules in the PV string. 2. Check whether the open-circuit voltage of the PV string is abnormal.

ID	Name	Severity	Cause	Solution
				3. Check whether the PV string is shaded.
2013	Abnormal string power	Warning	<ul style="list-style-type: none"> The PV string is shaded for a long time. The PV string is aged abnormally. Cause ID 1–8: PV strings 1–8	<ol style="list-style-type: none"> Check whether the current of the abnormal PV string is lower than that of other PV strings. If yes, check whether the abnormal PV string is shaded and the actual number of PV modules in the PV string is the same as the configured number. If the abnormal PV string is clean and not shaded, check whether the PV string is damaged.
2014	High input string voltage to ground	Major	Cause ID = 1 The voltage between the input PV modules and the ground is abnormal, and there is a risk of power degradation.	<ol style="list-style-type: none"> If no PID compensation device exists in the system, disable the PID protection function at night. Note: If the PID protection function is disabled but reactive power compensation at night is enabled, PV modules may be degraded. If the system has a PID compensation device, check whether the device is abnormal. If yes, rectify the fault. Check whether the settings of compensation direction for the inverter and the PID compensation device are consistent. If not, set them to be consistent based on the PV module model. (Note: If the PV– is set to positive offset, the voltage between the inverter PV– and the ground should be greater than 0 V to clear the alarm; if the PV+ is set to negative offset, the voltage between the inverter PV+ and the ground should be less than 0 V to clear the alarm.) If the alarm persists, contact your dealer or Huawei technical support.
2021	AFCI self-check failure	Major	Cause ID = 1, 2 The AFCI self-check fails.	Turn off the AC output switch and DC input switch, and then turn them on after 5 minutes. If the alarm persists, contact Huawei technical support.
2031	Phase wire short-circ	Major	Cause ID = 1 The impedance of the output	Check the impedance of the output phase wire to PE, locate the position with low impedance, and rectify the

ID	Name	Severity	Cause	Solution
	uited to PE		phase wire to PE is low or the output phase wire is short-circuited to PE.	fault.
2032	Grid loss	Major	Cause ID = 1 <ul style="list-style-type: none"> • Power grid outage occurs. • The AC circuit is disconnected or the AC switch is off. 	<ol style="list-style-type: none"> 1. The alarm is cleared automatically after the power grid recovers. 2. Check whether the AC circuit is disconnected or the AC switch is off.
2033	Grid undervoltage	Major	Cause ID = 1 The power grid voltage is below the lower threshold or the low-voltage duration has lasted for more than the value specified by LVRT.	<ol style="list-style-type: none"> 1. If the alarm occurs occasionally, the power grid may be abnormal temporarily. The inverter automatically recovers after detecting that the power grid becomes normal. 2. If the alarm persists, check whether the power grid voltage is within the acceptable range. If not, contact the local power operator. If yes, modify the grid undervoltage protection threshold through the app, SmartLogger, or NMS with the consent of the local power operator. 3. If the alarm persists for a long time, check the AC circuit breaker and AC output power cable.
2034	Grid overvoltage	Major	Cause ID = 1 The power grid voltage exceeds the upper threshold or the high voltage duration has lasted for more than the value specified by HVRT.	<ol style="list-style-type: none"> 1. If the alarm occurs occasionally, the power grid may be abnormal temporarily. The inverter automatically recovers after detecting that the power grid becomes normal. 2. If the alarm persists, check whether the power grid frequency is within the acceptable range. If not, contact the local power operator. If yes, modify the grid overfrequency protection threshold through the app, SmartLogger, or NMS with the consent of the local power operator. 3. Check whether the peak voltage of the power grid is too high. If the alarm persists and lasts for a long time, contact the local power operator.
2035	Grid volt. Imbalanc	Major	Cause ID = 1	<ol style="list-style-type: none"> 1. If the alarm occurs occasionally, the power grid may be abnormal

ID	Name	Severity	Cause	Solution
	e		The difference between power grid phase voltages exceeds the upper threshold.	<p>temporarily. The inverter automatically recovers after detecting that the power grid becomes normal.</p> <ol style="list-style-type: none"> If the alarm persists, check whether the power grid voltage is within the acceptable range. If not, contact the local power operator. If the alarm lasts for a long time, check the AC output power cable connection. If the AC output power cable is correctly connected, yet the alarm persists and affects the energy yield of the PV plant, contact the local power operator.
2036	Grid overfrequency	Major	<p>Cause ID = 1</p> <p>Power grid exception: The actual power grid frequency is higher than the requirements for the local power grid code.</p>	<ol style="list-style-type: none"> If the alarm occurs occasionally, the power grid may be abnormal temporarily. The inverter automatically recovers after detecting that the power grid becomes normal. If the alarm persists, check whether the power grid frequency is within the acceptable range. If not, contact the local power operator. If yes, modify the grid overfrequency protection threshold through the app, SmartLogger, or NMS with the consent of the local power operator.
2037	Grid underfrequency	Major	<p>Cause ID = 1</p> <p>Power grid exception: The actual power grid frequency is lower than the requirements for the local power grid code.</p>	<ol style="list-style-type: none"> If the alarm occurs occasionally, the power grid may be abnormal temporarily. The inverter automatically recovers after detecting that the power grid becomes normal. If the alarm persists, check whether the power grid frequency is within the acceptable range. If not, contact the local power operator. If yes, modify the grid underfrequency protection threshold through the app, SmartLogger, or NMS with the consent of the local power operator.
2038	Unstable grid	Major	<p>Cause ID = 1</p> <p>Power grid exception: The</p>	<ol style="list-style-type: none"> If the alarm occurs occasionally, the power grid may be abnormal

ID	Name	Severity	Cause	Solution
	frequency		actual change rate of the power grid frequency does not meet the requirements for the local power grid code.	temporarily. The inverter automatically recovers after detecting that the power grid becomes normal. 2. If the alarm persists, check whether the power grid frequency is within the acceptable range. If not, contact the local power operator.
2039	Output overcurrent	Major	Cause ID = 1 The power grid voltage drops dramatically or the power grid is short-circuited. As a result, the inverter transient output current exceeds the upper threshold, and protection is triggered.	1. The inverter monitors its external operating conditions in real time and automatically recovers after the fault is rectified. 2. If the alarm persists and affects the energy yield of the PV plant, check whether the output is short-circuited. If the fault cannot be rectified, contact your dealer or Huawei technical support.
2040	Output DC component overhigh	Major	Cause ID = 1 The DC component of the inverter output current exceeds the upper threshold.	1. The inverter monitors its external operating conditions in real time and automatically recovers after the fault is rectified. 2. If the alarm persists and affects the energy yield of the PV plant, contact your dealer or Huawei technical support.
2051	Abnormal residual current	Major	Cause ID = 1 The insulation impedance of the input side to PE decreases when the inverter is operating.	1. If the alarm occurs accidentally, the external power cable may be abnormal temporarily. The inverter automatically recovers after the fault is rectified. 2. If the alarm persists or lasts a long time, check whether the impedance between the PV string and ground is too low.
2061	Abnormal grounding	Major	Cause ID = 1 <ul style="list-style-type: none"> The neutral wire or PE cable of the inverter is not connected. The output mode set for the inverter is inconsistent with the cable connection mode. 	Power off the inverter (turn off the AC output switch and DC input switch, and wait for a period of time. For details about the wait time, see the description on the device safety warning label), and then perform the following operations: 1. Check whether the PE cable for the inverter is connected properly. 2. If the inverter is connected to a TN power grid, check whether the neutral wire is properly connected and whether the voltage of the neutral wire to

ID	Name	Severity	Cause	Solution
				<p>ground is normal.</p> <ol style="list-style-type: none"> After the inverter is powered on, check whether the output mode set for the inverter is consistent with the output cable connection mode.
2062	Low insulation resistance	Major	<p>Cause ID = 1</p> <ul style="list-style-type: none"> The PV array is short-circuited with PE. The PV string has been in a moist environment for a long time and the circuit is not well insulated to ground. 	<ol style="list-style-type: none"> Check the impedance between the PV string and the PE cable. If a short circuit occurs, rectify the fault. Check whether the PE cable of the inverter is correctly connected. If you have confirmed that the impedance is lower than the specified protection threshold in a cloudy or rainy environment, log in to the app, SmartLogger, or NMS and set Insulation resistance protection threshold.
2063	Cabinet overtemperature	Minor	<p>Cause ID = 1</p> <ul style="list-style-type: none"> The inverter is installed in a place with poor ventilation. The ambient temperature exceeds the upper threshold. The inverter is not operating properly. 	<ol style="list-style-type: none"> Check the ventilation and ambient temperature at the inverter installation position. If the ventilation is poor or the ambient temperature exceeds the upper threshold, improve the ventilation and heat dissipation. If both the ventilation and ambient temperature meet requirements yet the alarm persists, contact your dealer or Huawei technical support.
2064	Device fault	Major	<p>Cause ID = 1–15</p> <p>An unrecoverable fault occurs on a circuit inside the inverter.</p>	<p>Turn off the AC output switch and DC input switch, and then turn them on after 5 minutes. If the alarm persists, contact your dealer or Huawei technical support.</p> <p>NOTICE</p> <p>Cause ID = 1: Perform the preceding operations when the PV string current is less than 1 A.</p>
2065	Upgrade failed or version mismatch	Minor	<p>Cause ID = 1–6</p> <p>The upgrade is not completed normally.</p>	<ol style="list-style-type: none"> Perform an upgrade again. If the upgrade fails several times, contact your dealer or Huawei technical support.
2066	License expired	Warning	<p>Cause ID = 1</p> <ul style="list-style-type: none"> The privilege license has entered the grace period. The privilege feature is 	<ol style="list-style-type: none"> Apply for a new license. Load a new certificate.

ID	Name	Severity	Cause	Solution
			about to expire.	
61440	Faulty monitoring unit	Minor	Cause ID = 1 <ul style="list-style-type: none"> The flash memory is insufficient. The flash memory has bad sectors. 	Turn off the AC output switch and DC input switch, and then turn them on after 5 minutes. If the alarm persists, replace the monitoring board or contact your dealer or Huawei technical support.
2072	Transient AC overvoltage	Major	Cause ID = 1 The inverter detects that the phase voltage exceeds the transient AC overvoltage protection threshold.	<ol style="list-style-type: none"> If the voltage at the grid connection point is too high, contact the local power operator. If you have confirmed that the voltage at the grid connection point exceeds the upper threshold and obtained consent from the local power operator, modify the overvoltage protection thresholds. Check whether the peak grid voltage exceeds the upper threshold.
2085	Built-in PID operation abnormal	Minor	Cause ID = 1, 2 <ul style="list-style-type: none"> The output resistance of PV arrays to ground is low. The system insulation resistance is low. 	<ul style="list-style-type: none"> Cause ID = 1 <ol style="list-style-type: none"> Turn off the AC output switch and DC input switch, wait for a period of time (for details about the wait time, see the description on the device safety warning label), and then turn on the DC input switch and AC output switch. If the alarm persists, contact your dealer or Huawei technical support. Cause ID = 2 <ol style="list-style-type: none"> Check the impedance between the PV array output and the ground. If a short circuit occurs or the insulation is insufficient, rectify the fault. If the alarm persists, contact your dealer or Huawei technical support.
2087	Internal fan abnormal	Major	Cause ID = 1–4 The internal fan is short-circuited, the power supply is insufficient, or the fan is damaged.	Turn off the AC output switch and DC input switch, and then turn them on after 5 minutes. Wait for the inverter to connect to the power grid. If the alarm persists after 5 minutes, contact your dealer or Huawei technical support.

 **NOTE**

Contact your dealer or Huawei technical support if all troubleshooting procedures listed above are completed and the fault still exists.

10 Handling the Inverter

10.1 Removing the SUN2000

NOTICE

Before removing the SUN2000, disconnect both AC and DC connections.

Perform the following operations to remove the SUN2000:

1. Disconnect all cables from the SUN2000, including RS485 communications cables, DC input power cables, AC output power cables, and PGND cables.
2. Remove the SUN2000 from the mounting bracket.
3. Remove the mounting bracket.

10.2 Packing the SUN2000

- If the original packing materials are available, put the SUN2000 inside them and then seal them by using adhesive tape.
- If the original packing materials are not available, put the SUN2000 inside a suitable cardboard box and seal it properly.

10.3 Disposing of the SUN2000

If the SUN2000 service life expires, dispose of it according to the local disposal rules for electrical equipment waste.

11 Technical Specifications

11.1 SUN2000 V100 Spare Parts Technical Data

Efficiency

Technical Specifications	SUN2000-15K TL-M3	SUN2000-17K TL-M3	SUN2000-20K TL	SUN2000-23K TL-M3	SUN2000-28K TL-M3
Maximum efficiency	98.55%	98.57%	98.65%	98.65%	98.63%
European efficiency	98.08%	98.14%	98.22%	98.27%	97.92%

Input

Technical Specifications	SUN2000-15K TL-M3	SUN2000-17K TL-M3	SUN2000-20K TL	SUN2000-23K TL-M3	SUN2000-28K TL-M3
Maximum input voltage ^a	1100 V				
Maximum input current (per MPPT)	26 A				
Maximum short-circuit current (per MPPT)	40 A				
Minimum startup voltage	200 V				
MPP voltage range	200 V–1000 V				
Maximum number of	8				

Technical Specifications	SUN2000-15K TL-M3	SUN2000-17K TL-M3	SUN2000-20K TL	SUN2000-23K TL-M3	SUN2000-28K TL-M3
inputs					
Number of MPPTs	4				
Note a: The maximum input voltage is the maximum DC input voltage that the SUN2000 can withstand. If the input voltage exceeds this value, the SUN2000 may be damaged.					

Output

Technical Specifications	SUN2000-15K TL-M3	SUN2000-17K TL-M3	SUN2000-20K TL	SUN2000-23K TL-M3	SUN2000-28K TL-M3
Rated output power	15,000 W	17,000 W	20,000 W	23,000 W	27,500 W
Maximum apparent power	16,500 VA	18,700 VA	22,000 VA	23,000 VA	27,500 VA
Maximum active power (cosφ = 1)	16,500 W	18,700 W	22,000 W	23,000 W	27,500 W
Rated output voltage	220–230 V/380–400 V, 3W+N+PE				277 V AC/480 V AC, 3W+PE
Maximum output voltage at long-term operation	See standards about the local power grid.				
Maximum output current	25.2 A	28.5 A	33.5 A	35.1 A	33.5 A
Output voltage frequency	50 Hz/60 Hz				
Power factor	0.8 leading–0.8 lagging				
Maximum total harmonic distortion (THD) AC THDi	< 3% (at the rated power)				

Protection

Technical Specifications	SUN2000-15K TL-M3	SUN2000-17K TL-M3	SUN2000-20K TL	SUN2000-23K TL-M3	SUN2000-28K TL-M3
Input DC switch	Supported				
Islanding protection	Supported				
Output overcurrent protection	Supported				
Input reverse connection protection	Supported				
PV string fault detection	Supported				
DC surge protection	Type II				
AC surge protection	Type II				
Insulation resistance detection	Supported				
Residual current monitoring unit (RCMU)	Supported				

Display and Communication

Technical Specifications	SUN2000-15K TL-M3	SUN2000-17K TL-M3	SUN2000-20K TL	SUN2000-23K TL-M3	SUN2000-28K TL-M3
Display	LED indicators; WLAN+App				
RS485	Supported				
Built-in WLAN	Supported				
AFCI	Optional				

General Specifications

Technical Specifications	SUN2000-15K TL-M3	SUN2000-17K TL-M3	SUN2000-20K TL	SUN2000-23K TL-M3	SUN2000-28K TL-M3
Dimensions (W)	640 mm x 530 mm x 270 mm				

Technical Specifications	SUN2000-15K TL-M3	SUN2000-17K TL-M3	SUN2000-20K TL	SUN2000-23K TL-M3	SUN2000-28K TL-M3
x H x D)					
Net weight	43 kg				
Operating temperature	-25°C to +60°C				
Relative humidity	0%–100%				
Cooling mode	Natural convection				
Maximum operating altitude	3000 m				
IP rating	IP66				
Topology	Transformerless				

Standards Compliance

Technical Specifications	SUN2000-15K TL-M3	SUN2000-17K TL-M3	SUN2000-20K TL	SUN2000-23K TL-M3	SUN2000-28K TL-M3
Standards	EN/IEC62109-1, EN/IEC62109-2, NB/T32004-2013				

11.2 SUN2000 V200R001 Spare Parts Technical Data

Efficiency

Technical Specifications	SUN2000-25KTL-NAM3	SUN2000-30KTL-NAM3	SUN2000-30KTL-M3	SUN2000-36KTL-M3
Maximum efficiency	98.75%	98.75%	98.65% (400 V AC) 98.75% (480 V AC)	98.75%
European efficiency	98.29%	98.45%	98.40% (400 V AC) 98.45% (480 V AC)	98.5%
Chinese efficiency	/	/	98% (380V AC/400V AC)	98.18%

Input

Technical Specifications	SUN2000-25KTL-NAM3	SUN2000-30KTL-NAM3	SUN2000-30KTL-M3	SUN2000-36KTL-M3
Maximum input voltage ^a	1000 V		1100 V	
Maximum input current (per MPPT)	26 A			
Maximum short-circuit current (per MPPT)	40 A			
Minimum startup voltage	200 V			
MPP voltage range	200 V–1000 V			
Maximum number of inputs	8			
Number of MPPTs	4			
Note a: The maximum input voltage is the maximum DC input voltage that the SUN2000 can withstand. If the input voltage exceeds this value, the SUN2000 may be damaged.				

Output

Technical Specifications	SUN2000-25KTL-NAM3	SUN2000-30KTL-NAM3	SUN2000-30KTL-M3	SUN2000-36KTL-M3
Rated output power	25,000 W	30,000 W	30,000 W	36,000 W
Maximum apparent power	27,500 VA	33,000 VA	33,000 VA	40,000 VA
Maximum active power (cosφ = 1)	25,000 W	30,000 W	33,000 W (can be set to 30,000 W)	40,000 W
Rated output voltage	277/480 V, 3W/N+PE	480 V	220 V/380 V, 3W+(N)+PE 230 V/400 V, 3W+(N)+PE 277 V/480 V, 3W+PE	277 V/480 V, 3W+PE
Maximum output voltage at long-term operation	See standards about the local power grid.			
Maximum output current	33 A	40 A	50.4 A/380 V 47.9 A/400 V 39.9 A/480 V	48.4 A

Technical Specifications	SUN2000-25KTL-NAM3	SUN2000-30KTL-NAM3	SUN2000-30KTL-M3	SUN2000-36KTL-M3
Output voltage frequency	60 Hz		50 Hz/60 Hz	
Power factor	0.8 leading–0.8 lagging			
Maximum total harmonic distortion (THD) AC THDi	< 3% (at the rated power)			

Protection

Technical Specifications	SUN2000-25KTL-NAM3	SUN2000-30KTL-NAM3	SUN2000-30KTL-M3	SUN2000-36KTL-M3
Input DC switch	Supported			
Islanding protection	Supported			
Output overcurrent protection	Supported			
Input reverse connection protection	Supported			
PV string fault detection	Supported			
DC surge protection	Type II			
AC surge protection	Type II			
Insulation resistance detection	Supported			
Residual current monitoring unit (RCMU)	Supported			

Display and Communication

Technical Specifications	SUN2000-25KTL-NAM3	SUN2000-30KTL-NAM3	SUN2000-30KTL-M3	SUN2000-36KTL-M3
Display	LED and WLAN+app			
RS485	Supported			
Built-in WLAN	/		Supported	

Technical Specifications	SUN2000-25KTL-NAM3	SUN2000-30KTL-NAM3	SUN2000-30KTL-M3	SUN2000-36KTL-M3
AC MBUS	Optional			
AFCI	Supported		Optional	

General Specifications

Technical Specifications	SUN2000-25KTL-NAM3	SUN2000-30KTL-NAM3	SUN2000-30KTL-M3	SUN2000-36KTL-M3
Dimensions (W x H x D)	640 mm x 530 mm x 270 mm			
Net weight	43 kg			
Operating temperature	-25°C to +60°C			
Relative humidity	0%–100% (non-condensing)			
Cooling mode	Natural convection			
Maximum operating altitude	3000 m			
IP rating	Type 4X		IP66	
Topology	Transformerless			

Standards Compliance

Technical Specifications	SUN2000-25KTL-NAM3	SUN2000-30KTL-NAM3	SUN2000-30KTL-M3	SUN2000-36KTL-M3
Standards	EN/IEC62109-1, EN/IEC62109-2, NB/T32004-2013			

11.3 SUN2000 V200R002 Spare Parts Technical Data

Efficiency

Technical Specifications	SUN2000-29.9KTL-M3	SUN2000-30KTL-M3	SUN2000-36KTL-M3	SUN2000-42KTL-M3	SUN2000-43KTL-INM3	SUN2000-50KTL-M3	SUN2000-33KTL-NA M3	SUN2000-36KTL-NA M3	SUN2000-40KTL-NA M3
Maximum	98.65%	98.65%	98.65%	98.75%	98.75%	98.75%	98.75%	98.75%	98.75%

Technical Specifications	SUN2000-29.9KTL-M3	SUN2000-30KTL-M3	SUN2000-36KTL-M3	SUN2000-42KTL-M3	SUN2000-43KTL-INM3	SUN2000-50KTL-M3	SUN2000-33KTL-NA M3	SUN2000-36KTL-NA M3	SUN2000-40KTL-NA M3
Maximum efficiency			(380 Vac/400 V AC) 98.75% (480 V AC)						
European efficiency	98.4%	98.4%	98.40% (380 V AC/400 V AC) 98.50% (480 V AC)	98.48%	98.47%	98.46%	98.45% (480 V AC)	98.5% (480 V AC)	98.5% (480 V AC)
Chinese efficiency	/	/	/	/	/	98.17%	/	/	/
CEC efficiency	/	/	/	/	/	/	98.13%	98.13%	98.13%

Input

Technical Specifications	SUN2000-29.9KTL-M3	SUN2000-30KTL-M3	SUN2000-36KTL-M3	SUN2000-42KTL-M3	SUN2000-43KTL-INM3	SUN2000-50KTL-M3	SUN2000-33KTL-NA M3	SUN2000-36KTL-NA M3	SUN2000-40KTL-NA M3
Maximum input voltage ^a	1100 V						1000 V		
Maximum input current (per MPPT)	26 A								
Maximum short-circuit current (per MPPT)	40 A								
Minimum	200 V								

Technical Specifications	SUN2000-29.9KTL-M3	SUN2000-30KTL-M3	SUN2000-36KTL-M3	SUN2000-42KTL-M3	SUN2000-43KTL-INM3	SUN2000-50KTL-M3	SUN2000-33KTL-NA M3	SUN2000-36KTL-NA M3	SUN2000-40KTL-NA M3
m startup voltage									
MPP voltage range	200 V–1000 V								
Rated input voltage	/	620 V	/	720 V	750 V	/	/	/	720 V
Maximum number of inputs	8								
Number of MPPTs	4								
Note a: The maximum input voltage is the maximum DC input voltage that the SUN2000 can withstand. If the input voltage exceeds this value, the SUN2000 may be damaged.									

Output

Technical Specifications	SUN2000-29.9KTL-M3	SUN2000-30KTL-M3	SUN2000-36KTL-M3	SUN2000-42KTL-M3	SUN2000-43KTL-INM3	SUN2000-50KTL-M3	SUN2000-33KTL-NA M3	SUN2000-36KTL-NA M3	SUN2000-40KTL-NA M3
Rated output power	29,900 W	30,000 W	36,000 W	42,000 W	43,000 W	46,000 W (480 V) 47,500 W (500 V)	33,300 W	36,000 W	40,000 W
Maximum apparent power	29,900 VA	33,000 VA	40,000 VA	47,000 VA	52,500 VA	50,500 W (480 V) 52,500 W (500 V)	36,600 VA	40,000 VA	44,000 VA
Maximum active power (cosφ =	29,900 W	30,000 W	40,000 W (can be set to 36,000)	47,000 W (can be set to 42,000)	52,500 W	50,500 W (480 V) 52,500	36,600 W	40,000 W	44,000 W

Technical Specifications	SUN2000-29.9KTL-M3	SUN2000-30KTL-M3	SUN2000-36KTL-M3	SUN2000-42KTL-M3	SUN2000-43KTL-IN M3	SUN2000-50KTL-M3	SUN2000-33KTL-NA M3	SUN2000-36KTL-NA M3	SUN2000-40KTL-NA M3
1)			W)	W)		W (500 V)			
Rated output voltage	230 V/400 V, 3W+(N)+PE		220 V/380 V, 3W+(N)+PE 230 V/400 V, 3W+(N)+PE 277 V/480 V, 3W+PE	277 V/480 V, 3W+PE	288 V/500 V, 3W+PE	277 V/480 V, 3W+PE 288 V/500 V, 3W+PE	277 V/480 V, 3W+PE/3W+N+PE		
Maximum output voltage at long-term operation	See standards about the local power grid.								
Rated output current	/	/	/	/	49.7 A	55.3 A/480 V 54.9 A/500 V	40.1 A	43.4 A	48.2 A
Maximum output current	43.2 A	48 A	61.1 A/380 V 58.0 A/400 V 52.8 A/440 V (Mexico) 48.4 A/480 V	56.6 A/480 V	60.7 A	60.8 A/480 V 60.8 A/500 V	44.1 A	48.2 A	53 A
Output voltage frequency	50 Hz/60 Hz				50 Hz		60 Hz		

Technical Specifications	SUN2000-29.9KTL-M3	SUN2000-30KTL-M3	SUN2000-36KTL-M3	SUN2000-42KTL-M3	SUN2000-43KTL-INM3	SUN2000-50KTL-M3	SUN2000-33KTL-NA M3	SUN2000-36KTL-NA M3	SUN2000-40KTL-NA M3
Power factor	0.8 leading~0.8 lagging								
Maximum total harmonic distortion (THD) AC THDi	< 3% (at the rated power)								

Protection

Technical Specifications	SUN2000-29.9KTL-M3	SUN2000-30KTL-M3	SUN2000-36KTL-M3	SUN2000-42KTL-M3	SUN2000-43KTL-INM3	SUN2000-50KTL-M3	SUN2000-33KTL-NA M3	SUN2000-36KTL-NA M3	SUN2000-40KTL-NA M3
Input DC switch	Supported								
Islanding protection	Supported								
Output overcurrent protection	Supported								
Input reverse connection protection	Supported								
PV string fault detection	Supported								
DC surge	Type II								

Technical Specifications	SUN2000-29.9KTL-M3	SUN2000-30KTL-M3	SUN2000-36KTL-M3	SUN2000-42KTL-M3	SUN2000-43KTL-INM3	SUN2000-50KTL-M3	SUN2000-33KTL-NA M3	SUN2000-36KTL-NA M3	SUN2000-40KTL-NA M3
protection									
AC surge protection	Type II								
Insulation resistance detection	Supported								
Residual current monitoring unit (RCMU)	Supported								

Display and Communication

Technical Specifications	SUN2000-29.9KTL-M3	SUN2000-30KTL-M3	SUN2000-36KTL-M3	SUN2000-42KTL-M3	SUN2000-43KTL-INM3	SUN2000-50KTL-M3	SUN2000-33KTL-NA M3	SUN2000-36KTL-NA M3	SUN2000-40KTL-NA M3
Display	LED and WLAN+app								
RS485	Supported				Optional	Supported			
Built-in WLAN	Supported								/
AC MBUS	Supported								
AFCI	Optional				/	Supported			

General Specifications

Technical Specifications	SUN2000-29.9KTL-M3	SUN2000-30KTL-M3	SUN2000-36KTL-M3	SUN2000-42KTL-M3	SUN2000-43KTL-INM3	SUN2000-50KTL-M3	SUN2000-33KTL-NA M3	SUN2000-36KTL-NA M3	SUN2000-40KTL-NA M3
Dimensions (W x H x D)	640 mm x 530 mm x 270 mm								
Net weight	43 kg								
Operating temperature	-25°C to +60°C								
Relative humidity	0%–100% (non-condensing)								
Cooling mode	Natural convection								
Maximum operating altitude	3000 m								
IP rating	IP66						Type 4X		
Topology	Transformerless								

Standards Compliance

Technical Specifications	SUN2000-29.9KTL-M3	SUN2000-30KTL-M3	SUN2000-36KTL-M3	SUN2000-42KTL-M3	SUN2000-43KTL-INM3	SUN2000-50KTL-M3	SUN2000-33KTL-NA M3	SUN2000-36KTL-NA M3	SUN2000-40KTL-NA M3
Standards	EN/IEC62109-1, EN/IEC62109-2, NB/T32004-2013								

A Grid Code

NOTE

The grid codes are subject to change. The listed codes are for reference only.

No.	Grid Code	Description
1	VDE-AR-N-4105	Germany LV power grid
2	RD1699/661	Spain LV power grid
3	UTE C 15-712-1(A)	France mainland power grid
4	UTE C 15-712-1(B)	France island power grid
5	UTE C 15-712-1(C)	France island power grid
6	UTE C 15-712-1-MV480	France island power grid
7	EN50549-LV	Ireland, Netherlands, Poland, Switzerland, Hungary, Luxembourg, Czech Republic, Turkey, Sweden, Slovakia, Denmark, Norway, and Portugal
8	EN50549-MV400	Europe
9	EN50549-MV480	Ireland MV power grid
10	C10/11	Belgium
11	C11/C10-MV480	Belgium MV power grid
12	CEI0-16	Italy
13	CEI0-16-MV480	Italy MV
14	CEI0-21	Italy
15	CEI0-21-MV480	Italy MV
16	Austria	Austria
17	Austria-MV480	Austria
18	G99-TYPEA-LV	UK

No.	Grid Code	Description
19	G99-TYPEB-LV	UK
20	G99-TYPEB-HV	UK
21	G99-TYPEB-HV-MV480	UK
22	G99-TYPEA-HV	UK
23	ABNT NBR 16149	Brazil
24	ABNT NBR 16149-MV480	Brazil MV power grid
25	Philippines	Philippines LV power grid
26	Philippines-MV480	Philippines MV power grid
27	TAI-PEA	Thailand grid-tied standard power grid
28	TAI-PEA-MV480	Thailand MV grid-tied power grid (PEA)
29	TAI-MEA	Thailand grid-tied standard power grid
30	TAI-MEA-MV480	Thailand MV grid-tied power grid (MEA)
31	AS4777	Australia
32	AS4777-MV480	Australia MV
33	IEC61727	IEC 61727 LV grid-tied power grid (50 Hz)
34	IEC61727-MV480	IEC 61727 MV grid-tied power grid (50 Hz)
35	IEC61727-60Hz	IEC 61727 LV grid-tied power grid (60 Hz)
36	IEC61727-60Hz-MV480	IEC 61727 MV grid-tied power grid (60 Hz)
37	IEC61727-50Hz-MV500	India 500 V MV
38	INDIA	India LV power grid
39	INDIA-MV500	India MV power grid
40	NRS-097-2-1	South Africa standard power grid
41	NRS-097-2-1-MV480	South Africa MV
42	DUBAI	Dubai LV power grid
43	DUBAI-MV480	Dubai MV
44	VDE-AR-N4110	Europe
45	VDE-AR-N4110-MV480	Europe

B Setting the SUN2000 Output Mode

NOTICE

If the output mode set for the SUN2000 is inconsistent with the actual cable connection mode, the SUN2000 reports an **Abnormal Grounding** alarm. In this case, you need to change the output mode of the SUN2000.

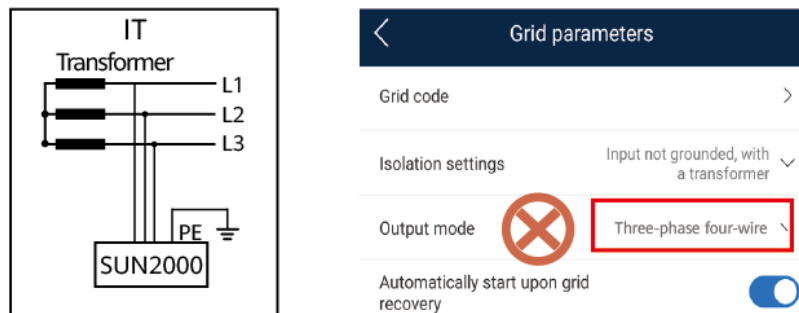

Procedure

Step 1 On the home screen, choose **Settings** > **Grid parameters** and set related parameters.

Figure B-1 Setting grid parameters

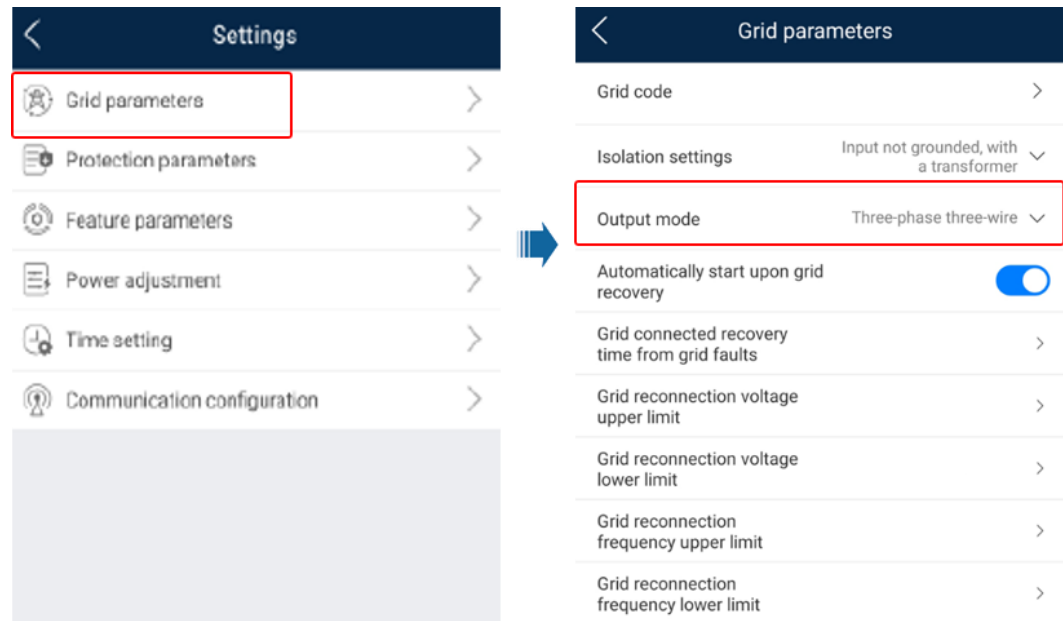

----End

C Setting Power Adjustment Parameters

Prerequisites

You have logged in to the app as **installer**.

Procedure

Step 1 On the home screen, tap **Power Adjustment** and set power parameters as required.

Figure C-1 Setting Power Adjustment Parameters

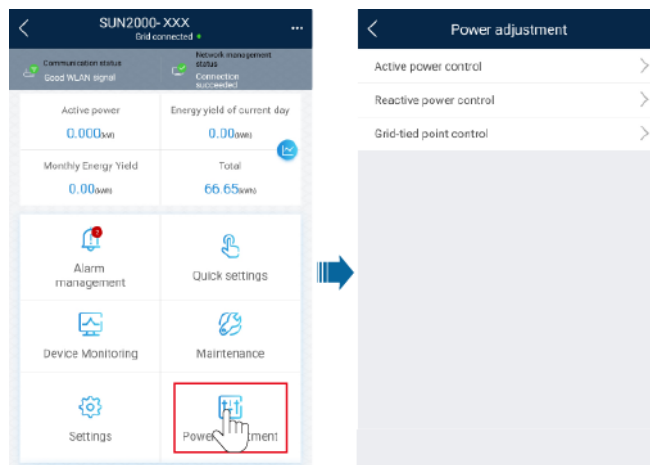

----End

D Built-in PID Recovery

NOTICE

Ensure that the inverter ground cable is securely connected. Otherwise, the built-in PID repair function will be affected and electric shocks may occur.

Prerequisites

You have logged in to the app as **installer**.

Procedure

Step 1 On the home screen, choose **Settings** > **Feature Parameters** and set related parameters.

Figure D-1 Setting PID suppression parameters

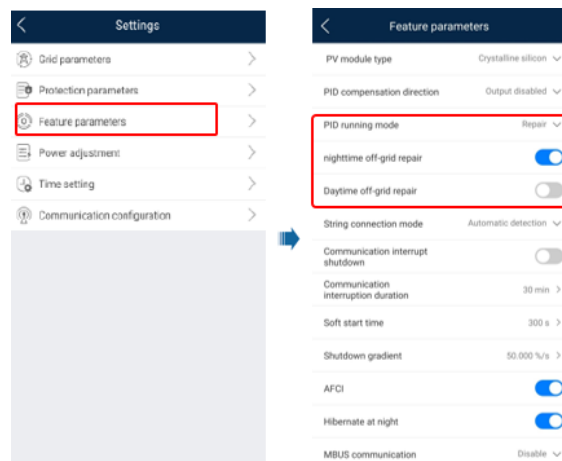





NOTE

- Set **PID running mode** to **Repair** (disabled by default).
- Set **Nighttime off-grid repair** to  (this parameter is displayed when **Built-in PID running mode** is set to **Repair**).

----End

E Resetting Password

- Step 1** Check that the AC and DC power supplies to the solar inverter are connected simultaneously, and that the  and  indicators are steady green or blink slowly for more than 3 minutes.
- Step 2** Turn off the AC switch, set the DC switch at the bottom of the solar inverter to OFF, and wait until all indicators on the solar inverter panel turn off.
- Step 3** Complete the following operations within 3 minutes:
1. Turn on the AC switch and wait until the  indicator blinks.
 2. Turn off the AC switch and wait until all indicators on the solar inverter panel turn off.
 3. Turn on the AC switch and wait until all LED indicators on the inverter panel blink and turn off after about 30s.
- Step 4** Wait until the three indicators on the inverter panel blink green quickly and then blink red quickly, indicating that the password has been restored.
- Step 5** Reset the password within 10 minutes. (If no operation is performed within 10 minutes, all parameters of the solar inverter remain the same as those before the reset.)
1. Wait until the  indicator blinks.
 2. Obtain the initial WLAN hotspot name (SSID) and initial password (PSW) from the label on the side of the solar inverter to connect to the app.
 3. On the login page, set a new login password and log in to the app.
- Step 6** Set router and management system parameters to implement remote management.

----End

NOTICE

You are advised to reset the password in the morning or at night when the solar irradiance is low.

F Setting Dry Contact Scheduling Parameters

Prerequisites

You have logged in to the app as **installer**.

Procedure

- Step 1** On the home screen, choose **Settings** > **Power adjustment** and set **Dry contact scheduling** to .

Figure F-1 Setting dry contact scheduling parameters

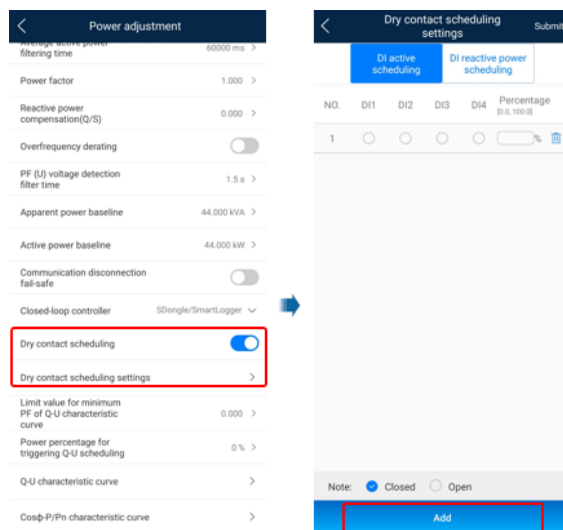

----End

G AFCI

Function

If PV modules or cables are not properly connected or damaged, electric arcs may occur, which may cause fire. Huawei SUN2000s provide unique arc detection in compliance with UL 1699B-2018 to ensure the safety of users' lives and property.

This function is enabled by default. The SUN2000 automatically detects arc faults. To disable this function, log in to the FusionSolar app, enter the **Device Commissioning** screen, choose **Settings > Feature parameters**, and disable **AFCI**.

Clearing Alarms

The AFCI function involves the **DC arc fault** alarm.

The SUN2000 has the AFCI alarm automatic clearance mechanism. If an alarm is triggered for less than five times within 24 hours, the SUN2000 automatically clears the alarm. If the alarm is triggered for five times or more within 24 hours, the SUN2000 locks for protection. You need to manually clear the alarm on the SUN2000 so that it can work properly.

You can manually clear the alarm as follows:

- **Method 1:** FusionSolar App
Log in to the FusionSolar app and choose **My > Device Commissioning**. On the **Device Commissioning** screen, connect and log in to the SUN2000 that generates the AFCI alarm, tap **Alarm management**, and tap **Clear** on the right of the **DC arc fault** alarm to clear the alarm.

Figure G-1 Alarm management

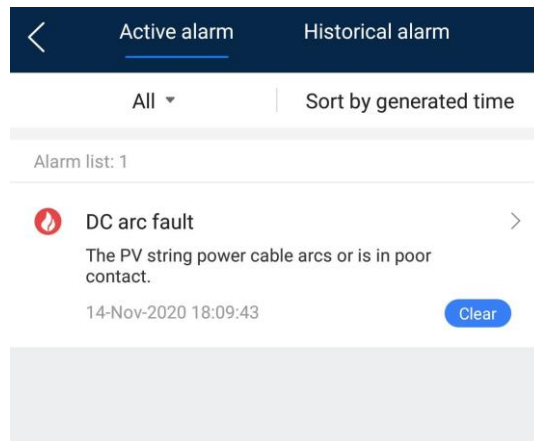

- **Method 2: FusionSolar Smart PV Management System**

Log in to the FusionSolar Smart PV Management System using a non-owner account, choose **Intelligent O&M > Alarm Management**, select the **DC arc fault** alarm, and click **Clear** to clear the alarm.

Figure G-2 Clearing alarms

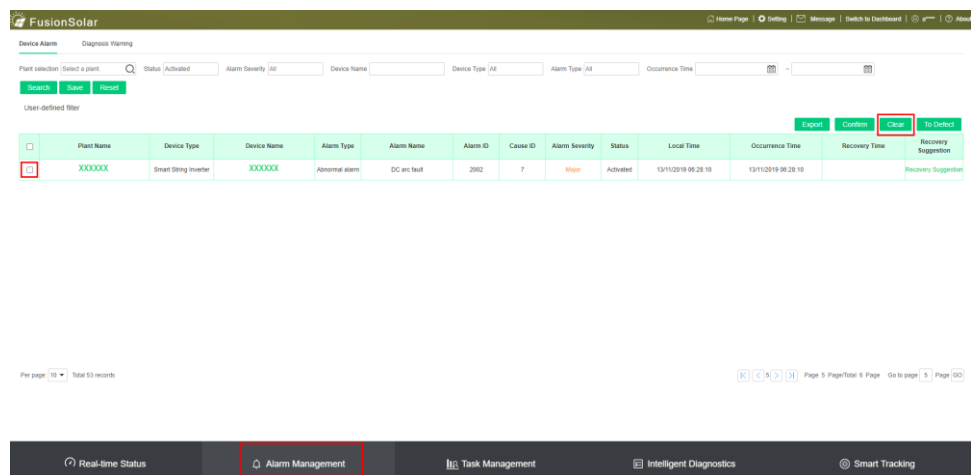

Switch to the owner account with PV plant management rights. On the home page, click the PV plant name to go to the PV plant page, and click **OK** as prompted to clear the alarm.

Figure G-3 Owner confirmation

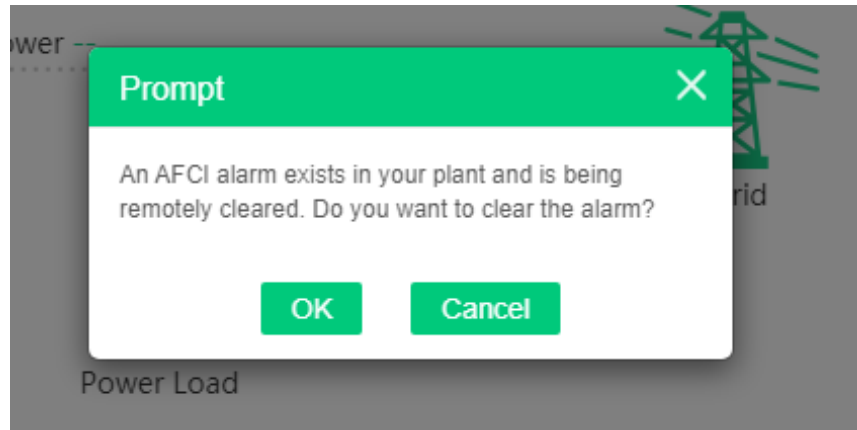

H Smart I-V Curve Diagnosis

For details, see [FusionSolar 6.0 Smart PV Management System Smart I-V Curve Diagnosis User Manual](#).

I FCC Supplier's Declaration of Conformity (SDoC)

NOTE

This equipment is intended to be used at locations where the separation distance to third party sensitive radio services is > 30 m.

For FCC application Version

This device complies with part 15 of the FCC Rules. Operation is subject to the following two conditions: (1) This device may not cause harmful interference, and (2) this device must accept any interference received, including interference that may cause undesired operation.

Changes or modifications not expressly approved by the party responsible for compliance could void the user's authority to operate the equipment.

This equipment has been tested and found to comply with the limits for a Class A digital device, pursuant to part 15 of the FCC Rules. These limits are designed to provide reasonable protection against harmful interference when the equipment is operated in a commercial environment. This equipment generates, uses, and can radiate radio frequency energy and, if not installed and used in accordance with the instruction manual, may cause harmful interference to radio communications. Operation of this equipment in a residential area is likely to cause harmful interference in which case the user will be required to correct the interference at his own expense.

MPE Requirements

To satisfy FCC RF exposure requirements, a separation distance of 20 cm or more should be maintained between the antenna of this device and persons during device operation.

To ensure compliance, operations at closer than this distance is not recommended.

J IC Supplier's Declaration of Conformity (SDoC)

For IC application Version

This device complies with Industry Canada's licence-exempt RSSs. Operation is subject to the following two conditions:

(1) This device may not cause interference; and (2) This device must accept any interference, including interference that may cause undesired operation of the device.

Le présent appareil est conforme aux CNR d'Industrie Canada applicables aux appareils radio exempts de licence. L'exploitation est autorisée aux deux conditions suivantes : (1) l'appareil ne doit pas produire de brouillage, et (2) l'utilisateur de l'appareil doit accepter tout brouillage radioélectrique subi, même si le brouillage est susceptible d'en compromettre le fonctionnement.

MPE Requirements

To satisfy IC RF exposure requirements, a separation distance of 20 cm or more should be maintained between the antenna of this device and persons during device operation.

To ensure compliance, operations at closer than this distance is not recommended.

Les antennes installées doivent être situées de façon à ce que la population ne puisse y être exposée à une distance de moins de 20 cm. Installer les antennes de façon à ce que le personnel ne puisse approcher à 20 cm ou moins de la position centrale de l'antenne.

La FCC des états-unis stipule que cet appareil doit être en tout temps éloigné d'au moins 20 cm des personnes pendant son fonctionnement.

K Acronyms and Abbreviations

A

AFCI arc-fault circuit interrupter

L

LED light emitting diode

M

MBUS monitoring bus

MPP maximum power point

MPPT maximum power point tracking

P

PE protective earthing

PID potential induced degradation

PV photovoltaic

R

RCD residual current device