



HUAWEI ME909u-521 LTE Mini PCIe Module

# Hardware Guide

Issue 02  
Date 2015-05-30

## **Copyright © Huawei Technologies Co., Ltd. 2015. All rights reserved.**

No part of this manual may be reproduced or transmitted in any form or by any means without prior written consent of Huawei Technologies Co., Ltd. and its affiliates ("Huawei").

The product described in this manual may include copyrighted software of Huawei and possible licensors. Customers shall not in any manner reproduce, distribute, modify, decompile, disassemble, decrypt, extract, reverse engineer, lease, assign, or sublicense the said software, unless such restrictions are prohibited by applicable laws or such actions are approved by respective copyright holders.

## **Trademarks and Permissions**



HUAWEI, HUAWEI, and  are trademarks or registered trademarks of Huawei Technologies Co., Ltd.

LTE is a trade mark of ETSI.

Other trademarks, product, service and company names mentioned may be the property of their respective owners.

## **Notice**

Some features of the product and its accessories described herein rely on the software installed, capacities and settings of local network, and therefore may not be activated or may be limited by local network operators or network service providers.

Thus, the descriptions herein may not exactly match the product or its accessories which you purchase.

Huawei reserves the right to change or modify any information or specifications contained in this manual without prior notice and without any liability.

## **DISCLAIMER**

ALL CONTENTS OF THIS MANUAL ARE PROVIDED "AS IS". EXCEPT AS REQUIRED BY APPLICABLE LAWS, NO WARRANTIES OF ANY KIND, EITHER EXPRESS OR IMPLIED, INCLUDING BUT NOT LIMITED TO, THE IMPLIED WARRANTIES OF MERCHANTABILITY AND FITNESS FOR A PARTICULAR PURPOSE, ARE MADE IN RELATION TO THE ACCURACY, RELIABILITY OR CONTENTS OF THIS MANUAL.

TO THE MAXIMUM EXTENT PERMITTED BY APPLICABLE LAW, IN NO EVENT SHALL HUAWEI BE LIABLE FOR ANY SPECIAL, INCIDENTAL, INDIRECT, OR CONSEQUENTIAL DAMAGES, OR LOSS OF PROFITS, BUSINESS, REVENUE, DATA, GOODWILL SAVINGS OR ANTICIPATED SAVINGS REGARDLESS OF WHETHER SUCH LOSSES ARE FORSEEABLE OR NOT.

THE MAXIMUM LIABILITY (THIS LIMITATION SHALL NOT APPLY TO LIABILITY FOR PERSONAL INJURY TO THE EXTENT APPLICABLE LAW PROHIBITS SUCH A LIMITATION) OF HUAWEI ARISING FROM THE USE OF THE PRODUCT DESCRIBED IN THIS MANUAL SHALL BE LIMITED TO THE AMOUNT PAID BY CUSTOMERS FOR THE PURCHASE OF THIS PRODUCT.

## **Import and Export Regulations**

Customers shall comply with all applicable export or import laws and regulations and be responsible to obtain all necessary governmental permits and licenses in order to export, re-export or import the product mentioned in this manual including the software and technical data therein.

## **Privacy Policy**

To better understand how we protect your personal information, please see the privacy policy at <http://consumer.huawei.com/privacy-policy>.



## About This Document

### Revision History

Document Version	Date	Chapter	Descriptions
01	2014-01-23		Creation
02	2015-05-30	2.2	Updated Table 2-1 Features
		2.3	Updated Figure 2-1 Circuit block diagram
		3	Updated Figure 3-1 definitions of pins
		3.7	Updated Audio Interface
		4.4.2	Updated Table 4-4 Conducted Tx power
		4.6	Added Co-existence with 5 GHz WIFI Design Guide
		5.4.1	Updated note and Table 5-4 Requirements for input current of the ME909u-521 Mini PCIe module
		5.4	Deleted 5.4 Electrical Features of USIM
		5.5	Deleted 5.5 Electrical Features of Application Interfaces
		6.4	Added Packaging
		6.5	Updated Figure 6-3 ME909u-521 Mini PCIe module label
		6.6.1	Updated note in 6.6.1 Installing the Mini PCIe Adapter on the Main Board
9	Updated Appendix A Circuit of Typical Interface		



---

# Contents

---

<b>1 Introduction</b>	<b>7</b>
<b>2 Overall Description</b>	<b>8</b>
2.1 About This Chapter	8
2.2 Function Overview	8
2.3 Circuit Block Diagram	9
<b>3 Description of the Application Interfaces</b>	<b>11</b>
3.1 About This Chapter	11
3.2 Mini PCIe Interface	11
3.3 Power Interface	16
3.3.1 Power Sources and Grounds	16
3.3.2 Power Supply Time Sequence	16
3.4 Signal Control Interface	17
3.4.1 Overview	17
3.4.2 WAKE# Signal	18
3.4.3 RESIN_N Signal	19
3.4.4 W_DISABLE# Signal	21
3.4.5 LED_WWAN# Signal	21
3.5 USB Interface	21
3.6 USIM Card Interface	22
3.6.1 Overview	22
3.6.2 Circuit Recommended for the USIM Card Interface	23
3.7 Audio Interface	24
3.8 RF Antenna Connector	25
3.9 Reserved Pins	26
3.10 NC Pins	26
<b>4 RF Specifications</b>	<b>28</b>
4.1 About This Chapter	28
4.2 Operating Frequencies	28
4.3 Conducted RF Measurement	29
4.3.1 Test Environment	29
4.3.2 Test Standards	29
4.4 Conducted Rx Sensitivity and Tx Power	29



4.4.1 Conducted Receive Sensitivity .....	29
4.4.2 Conducted Transmit Power .....	31
4.5 Antenna Design Requirements .....	32
4.5.1 Antenna Design Indicators.....	32
4.5.2 Interference .....	34
4.5.3 Antenna Requirements .....	35
4.6 Co-existence with 5 GHz WIFI Design Guide .....	36
4.6.1 Purpose .....	36
4.6.2 Co-existence Design Main Point .....	36
<b>5 Electrical and Reliability Features .....</b>	<b>38</b>
5.1 About This Chapter.....	38
5.2 Absolute Ratings .....	38
5.3 Operating and Storage Temperatures.....	39
5.4 Power Supply Features .....	39
5.4.1 Input Power Supply .....	39
5.4.2 Power Consumption .....	40
5.5 Reliability Features.....	45
5.6 EMC and ESD Features.....	48
<b>6 Mechanical Specifications .....</b>	<b>50</b>
6.1 About This Chapter.....	50
6.2 Dimensions and Interfaces.....	50
6.3 Dimensions of the Mini PCI Express Connector .....	51
6.4 Packaging.....	52
6.5 Label.....	53
6.6 Specification Selection for Fasteners.....	54
6.6.1 Installing the Mini PCIe Adapter on the Main Board.....	54
6.6.2 Removing the Mini PCIe Adapter from the Main Board .....	56
6.7 Antenna Plug .....	57
6.8 Thermal Design Guide .....	58
<b>7 Certifications.....</b>	<b>60</b>
7.1 About This Chapter.....	60
7.2 Certifications.....	60
<b>8 Safety Information.....</b>	<b>61</b>
8.1 Interference .....	61
8.2 Medical Device .....	61
8.3 Area with Inflammables and Explosives.....	61
8.4 Traffic Security.....	62
8.5 Airline Security.....	62
8.6 Safety of Children.....	62
8.7 Environment Protection .....	62



---

8.8 WEEE Approval.....	62
8.9 RoHS Approval.....	62
8.10 Laws and Regulations Observance .....	63
8.11 Care and Maintenance .....	63
8.12 Emergency Call.....	63
8.13 Regulatory Information.....	63
8.13.1 CE Approval (European Union) .....	63
<b>9 Appendix A Circuit of Typical Interface.....</b>	<b>64</b>
<b>10 Appendix B Acronyms and Abbreviations.....</b>	<b>65</b>



# 1 Introduction

---

This document describes the hardware application interfaces and air interfaces provided by HUAWEI ME909u-521 Mini PCIe module (hereinafter referred to as the ME909u-521 Mini PCIe module).

This document helps hardware engineer to understand the interface specifications, electrical features and related product information of the ME909u-521 Mini PCIe module.

# 2 Overall Description

## 2.1 About This Chapter

This chapter gives a general description of the ME909u-521 Mini PCIe module and provides:

- Function Overview
- Circuit Block Diagram

## 2.2 Function Overview

**Table 2-1** Features

Feature	Description
Physical Dimensions	<ul style="list-style-type: none"><li>• Dimensions (L x W x H): 51 mm x 30.4 mm x 3.35 mm</li><li>• Weight: about 12 g</li></ul>
Operating Bands	<ul style="list-style-type: none"><li>• LTE: FDD Band 1, Band 2, Band 3, Band 5, Band 7, Band 8, Band 20, all bands with diversity</li><li>• WCDMA/HSDPA/HSUPA/HSPA+: Band 1, Band 2, Band 5, Band 8, all bands with diversity</li><li>• GSM/GPRS/EDGE: 850 MHz/900 MHz/1800 MHz/1900 MHz</li><li>• GPS/GLONASS: L1</li></ul>
Operating Temperature	-20°C to +60°C
Storage Temperature	-40°C to +85°C
Power Voltage	DC 3.0 V–3.6 V (typical value is 3.3 V)
AT Commands	See <a href="#">HUAWEI ME909u-521 LTE LGA Module AT Command Interface Specification</a> .

Feature	Description
Application Interface (52-pin Mini PCIe interface)	One standard USIM (Universal Subscriber Identity Module) card (Class B and Class C)
	Audio interface: PCM interface
	USB 2.0 (High Speed)
	RESIN_N: Reset module
	WAKE#: Wake up signal
	W_DISABLE# signal (the firmware with this feature is in plan)
	LED_WWAN#: Active-low LED signal indicating the state of the module (the software is under development)
Antenna Connector	WWAN MAIN antenna connector x1 WWAN AUX antenna connector x1 GPS antenna connector x1
Data Services	GPRS: DL 85.6 kbit/s; UL 85.6 kbit/s
	EDGE: DL 236.8 kbit/s; UL 236.8 kbit/s
	WCDMA CS: DL 64 kbit/s; UL 64 kbit/s
	WCDMA PS: DL 384 kbit/s; UL 384 kbit/s
	HSPA+: DL 21.6 Mbit/s; UL 5.76 Mbit/s
	DC-HSPA+: DL 43.2 Mbit/s; UL 5.76 Mbit/s
	LTE FDD: DL 100 Mbit/s; UL 50 Mbit/s @20M BW cat3

## 2.3 Circuit Block Diagram

Figure 2-1 shows the circuit block diagram of the ME909u-521 Mini PCIe module. The major functional unit of the Mini PCIe module contains the following parts:

- LGA module
- Control signals
- Antenna connectors

**Figure 2-1** Circuit block diagram

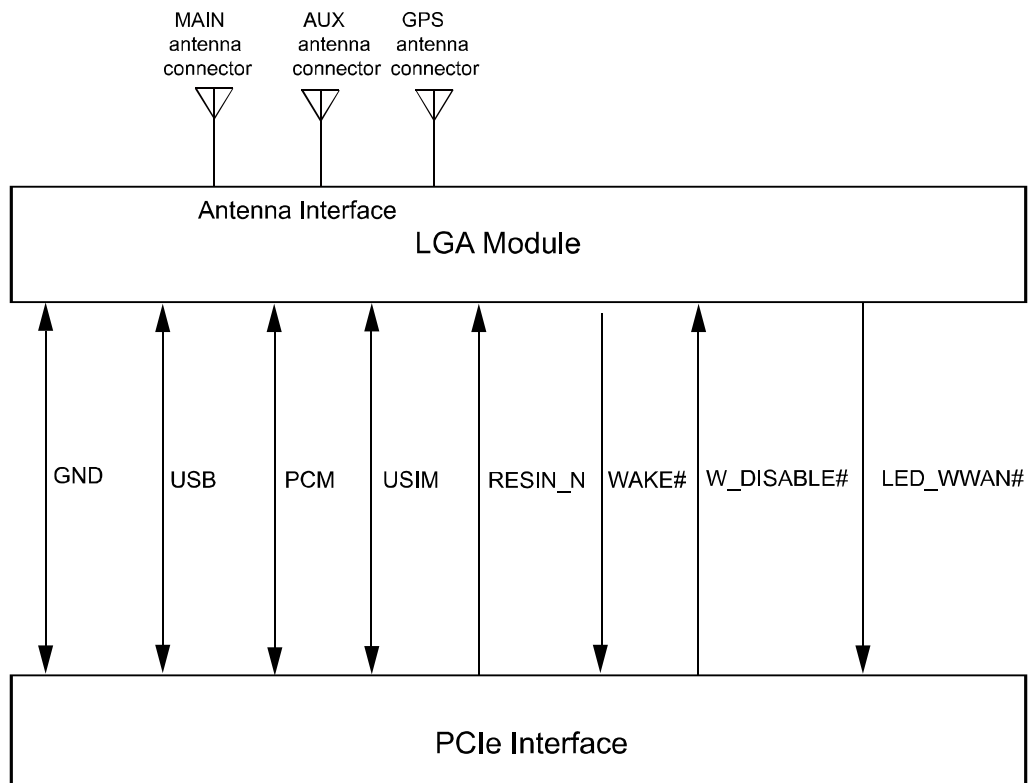

# 3 Description of the Application Interfaces

---

## 3.1 About This Chapter

This chapter mainly describes the external application interfaces of the ME909u-521 Mini PCIe module, including:

- Mini PCIe Interface
- Power Interface
- Signal Control Interface
- USB Interface
- USIM Card Interface
- Audio Interface
- RF Antenna Connector
- Reserved Pins
- NC Pins

## 3.2 Mini PCIe Interface

The ME909u-521 Mini PCIe module uses a Mini PCIe interface as its external interface. For details about the module and dimensions, see 6.2 Dimensions and Interfaces.

Figure 3-1 shows the sequence of pins on the interface of the Mini PCIe Adapter.

**Figure 3-1** Sequence of Mini PCIe interface

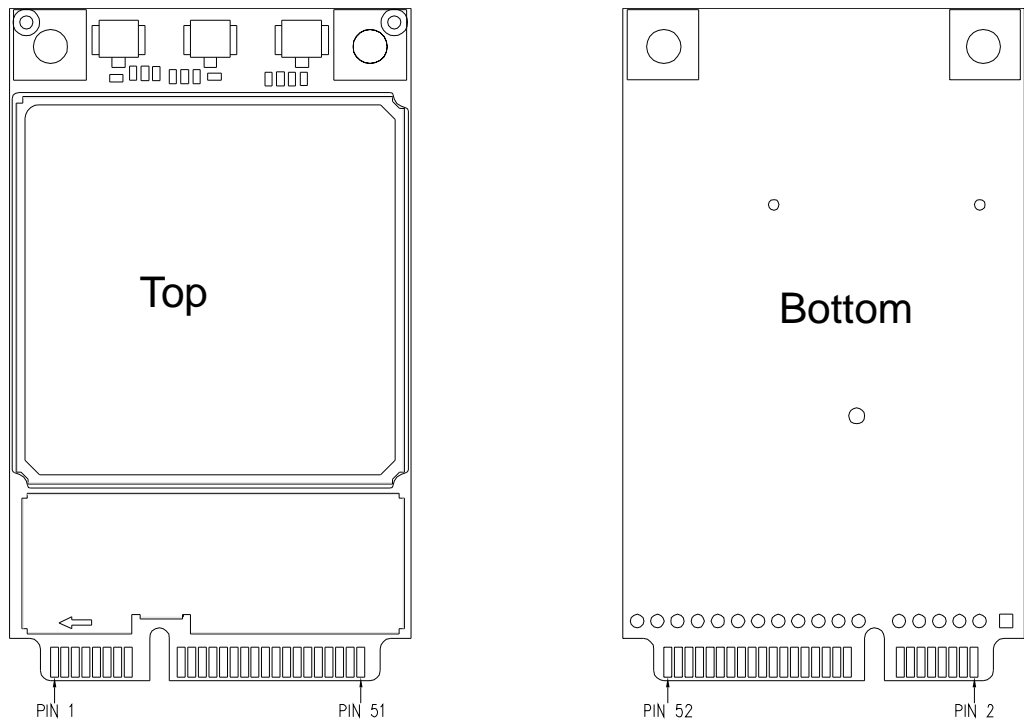

Table 3-1 shows the pin definitions of the Mini PCIe interface.

**Table 3-1** Pin definitions of the Mini PCIe interface

Pin No.	Pin Name		Pad Type	Description	Parameter	Min. (V)	Typ. (V)	Max. (V)	Comments
	Mini PCI Express Standard Description	HUAWEI Pin Description							
1	WAKE#	WAKE#	O	Open collector active low signal. This signal is used to wake up the host.	-	-0.3	-	0.45	-
2	3.3Vaux	VCC_3V3	PI	3.3 V DC supply rails from the PC side.	-	3.0	3.3	3.6	-
3	COEX1	NC	-	Not connected	-	-	-	-	-
4	GND	GND	-	Ground	-	-	-	-	-
5	COEX2	NC	-	Not connected	-	-	-	-	-



Pin No.	Pin Name		Pad Type	Description	Parameter	Min. (V)	Typ. (V)	Max. (V)	Comments
	Mini PCI Express Standard Description	HUAWEI Pin Description							
6	1.5 V	NC	-	Not connected	-	-	-	-	-
7	CLKREQ#	NC	-	Not connected	-	-	-	-	-
8	UIM_PWR	USIM_PWR	P	Power source for the external USIM card	-	-	1.8/2.85	-	-
9	GND	GND	-	Ground	-	-	-	-	-
10	UIM_DATA	USIM_DATA	I/O	External USIM data signal	-	-	1.8/2.85	-	-
11	REFCLK-	NC	-	Not connected	-	-	-	-	-
12	UIM_CLK	USIM_CLK	O	External USIM clock signal	-	-	1.8/2.85	-	-
13	REFCLK+	NC	-	Not connected	-	-	-	-	-
14	UIM_RESET	USIM_RESET	O	External USIM reset signal	-	-	1.8/2.85	-	-
15	GND	GND	-	Ground	-	-	-	-	-
16	UIM_Vpp	NC	-	Not connected	-	-	-	-	-
17	Reserved	Reserved	-	Reserved	-	-	-	-	-
18	GND	GND	-	Ground	-	-	-	-	-
19	Reserved	Reserved	-	Reserved	-	-	-	-	-
20	W_DISABLE#	W_DISABLE#	I	The W_DISABLE# signal is an active low signal that when asserted (driven low) by the system shall disable radio operation. The software version is in plan.	V <sub>IL</sub>	-0.3	0	0.2	-
					V <sub>IH</sub>	1.17	1.8	3.6	
21	GND	GND	-	Ground	-	-	-	-	-
22	PERST#	RESIN_N	I	Reset module Active-low	V <sub>IL</sub>	-0.3	0	0.2	-
					V <sub>IH</sub>	1.17	1.8	3.6	



Pin No.	Pin Name		Pad Type	Description	Parameter	Min. (V)	Typ. (V)	Max. (V)	Comments
	Mini PCI Express Standard Description	HUAWEI Pin Description							
23	PERn0	NC	-	Not connected	-	-	-	-	-
24	3.3Vaux	VCC_3V3	PI	3.3 V DC supply rails from the PC side.	-	3.0	3.3	3.6	-
25	PERp0	NC	-	Not connected	-	-	-	-	-
26	GND	GND	-	Ground	-	-	-	-	-
27	GND	GND	-	Ground	-	-	-	-	-
28	1.5 V	NC	-	Not connected	-	-	-	-	-
29	GND	GND	-	Ground	-	-	-	-	-
30	SMB_CLK	NC	-	Not connected	-	-	-	-	-
31	PETn0	NC	-	Not connected	-	-	-	-	-
32	SMB_DATA	NC	-	Not connected	-	-	-	-	-
33	PETp0	NC	-	Not connected	-	-	-	-	-
34	GND	GND	-	Ground	-	-	-	-	-
35	GND	GND	-	Ground	-	-	-	-	-
36	USB_D-	USB_DM	I/O	USB signal D-	-	-	-	-	-
37	GND	GND	-	Ground	-	-	-	-	-
38	USB_D+	USB_DP	I/O	USB signal D+	-	-	-	-	-
39	3.3Vaux	VCC_3V3	PI	3.3 V DC supply rails from the PC side	-	3.0	3.3	3.6	-
40	GND	GND	-	Ground	-	-	-	-	-
41	3.3Vaux	VCC_3V3	PI	3.3 V DC supply rails from the PC side	-	3.0	3.3	3.6	-



Pin No.	Pin Name		Pad Type	Description	Parameter	Min. (V)	Typ. (V)	Max. (V)	Comments
	Mini PCI Express Standard Description	HUAWEI Pin Description							
42	LED_WWAN#	LED_WWAN#	O	Active-low LED signal indicating the state of the card  The software feature is under development and do not support this function now.  Drive strength: 10 mA	-	-	-	-	-
43	GND	GND	-	Ground	-	-	-	-	-
44	LED_WLAN#	NC	-	Not connected	-	-	-	-	-
45	Reserved	PCM_CLK	O	PCM interface clock	V <sub>OH</sub>	1.35	1.8	1.8	-
					V <sub>OL</sub>	0	-	0.45	
46	LED_WPAN#	NC	-	Not connected	-	-	-	-	-
47	Reserved	PCM_DOUT	O	PCM I/F data out	V <sub>OH</sub>	1.35	1.8	1.8	-
					V <sub>OL</sub>	0	-	0.45	
48	1.5 V	NC	-	Not connected	-	-	-	-	-
49	Reserved	PCM_DIN	I	PCM I/F data in	V <sub>IH</sub>	1.17	1.8	2.1	-
					V <sub>IL</sub>	-0.3	-	0.63	
50	GND	GND	-	Ground	-	-	-	-	-
51	Reserved	PCM_SYNC	O	PCM interface sync	V <sub>OH</sub>	1.35	1.8	1.8	-
					V <sub>OL</sub>	0	-	0.45	
52	3.3Vaux	VCC_3V3	P	3.3 V DC supply rails from the PC side	-	3.0	3.3	3.6	-



**NOTE**

- **P** indicates power pins; **I** indicates pins for digital signal input; **O** indicates pins for digital signal output. **PO** indicates power output pins; **PI** indicates power input pins.
- **V<sub>IL</sub>** indicates Low-level Input voltage; **V<sub>IH</sub>** indicates High-level Input voltage; **V<sub>OL</sub>** indicates Low-level Output voltage; **V<sub>OH</sub>** indicates High-level Output voltage.
- The **Reserved** pins are internally connected to the module. Therefore, these pins should not be used, otherwise they may cause problems. Please contact with us for more details about this information.
- The **NC** (Not Connected) pins are floating and there are no signal connected to these pins. Therefore, these pins should not be used.

## 3.3 Power Interface

### 3.3.1 Power Sources and Grounds

For the Mini PCIe Adapter, +3.3 Vaux is the only voltage supply that is available. The input voltage is 3.3 V±9%, as specified by [PCI Express Mini CEM Specifications 1.2](#).

**Table 3-2** Power and ground specifications

Pin No.	Pin Name	Pad Type	Description	Parameter	Min. (V)	Typ. (V)	Max. (V)
2, 24, 39, 41 and 52	VCC_3V3	PI	3.3 V DC supply rails from the PC side.	-	3.0	3.3	3.6
4, 9, 15, 18, 21, 26, 27, 29, 34, 35, 37, 40, 43, and 50	GND	-	Ground	-	-	-	-



**NOTE**

To minimize the RF radiation through the power lines, it is suggested to add ceramic capacitors of 10 pF and 100 nF in the power lines beside the Mini PCIe connector on the host side.

### 3.3.2 Power Supply Time Sequence

#### Power on sequence

Do not toggle RESIN\_N pin during the power on sequence. Pulling RESIN\_N pin low will extend time for module startup.

**Figure 3-2** Power on timing sequence

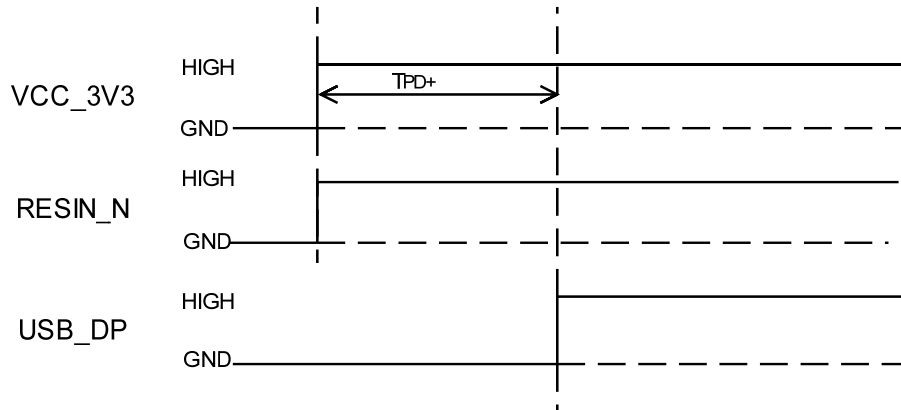

Parameter	Remarks	Time (Nominal value)	Unit
T <sub>PD+</sub>	Power Valid to USB D+ high	14	s

## Power off Sequence

Cutting off 3.3 V will power off the module.

**Figure 3-3** Power off timing sequence

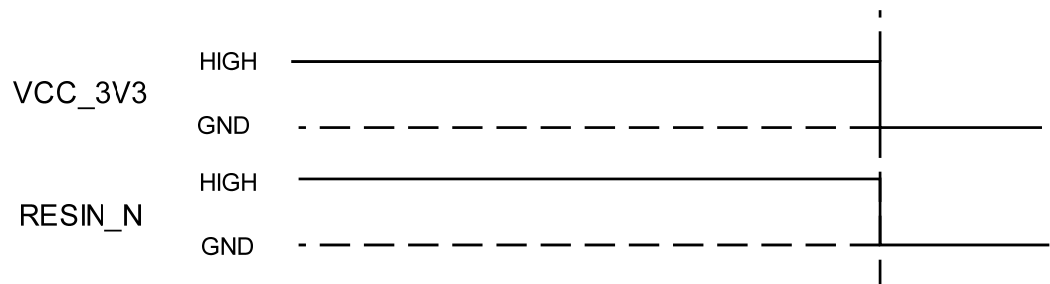

## 3.4 Signal Control Interface

### 3.4.1 Overview

The signal control part of the interface in the ME909-521 Mini PCIe module consists of the following:

- WAKE# Signal
- RESIN\_N Signal
- W\_DISABLE# Signal
- LED\_WWAN# Signal

**Table 3-3** Definitions of the pins on the signal control interface

Pin No.	Pin Name	Pad Type	Description	Parameter	Min. (V)	Typ. (V)	Max. (V)
1	WAKE#	O	Open collector active low signal. This signal is used to wake up the host.	-	-0.3	-	0.45
22	RESIN_N	I	Reset module Active-low	V <sub>IL</sub>	-0.3	0	0.2
				V <sub>IH</sub>	1.17	1.8	3.6
20	W_DISABLE#	I	The W_DISABLE# signal is an active low signal that when asserted (driven low) by the system shall disable radio operation. The software version is in plan.	V <sub>IL</sub>	-0.3	0	0.2
				V <sub>IH</sub>	1.17	1.8	3.6
42	LED_WWAN#	O	Active-low LED signal indicating the state of the card  The software feature is under development and do not support this function now.  Drive strength: 10 mA	-	-	-	-

### 3.4.2 WAKE# Signal

WAKE# pin (the signal that the module uses to wake up the PC) supports software control.

This signal is used for module to wake up the host. It is designed as an OC gate, so it should be pulled up by the host and it is active-low.

When the module wakes up the host, the WAKE# pin will output low-level-voltage to wake the host.

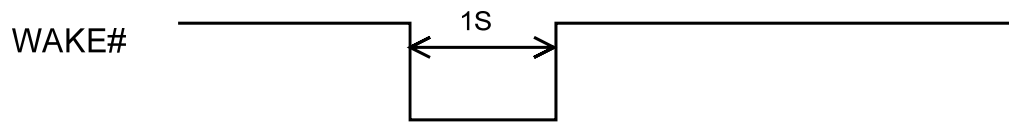

**Figure 3-4** Connections of the WAKE# pin

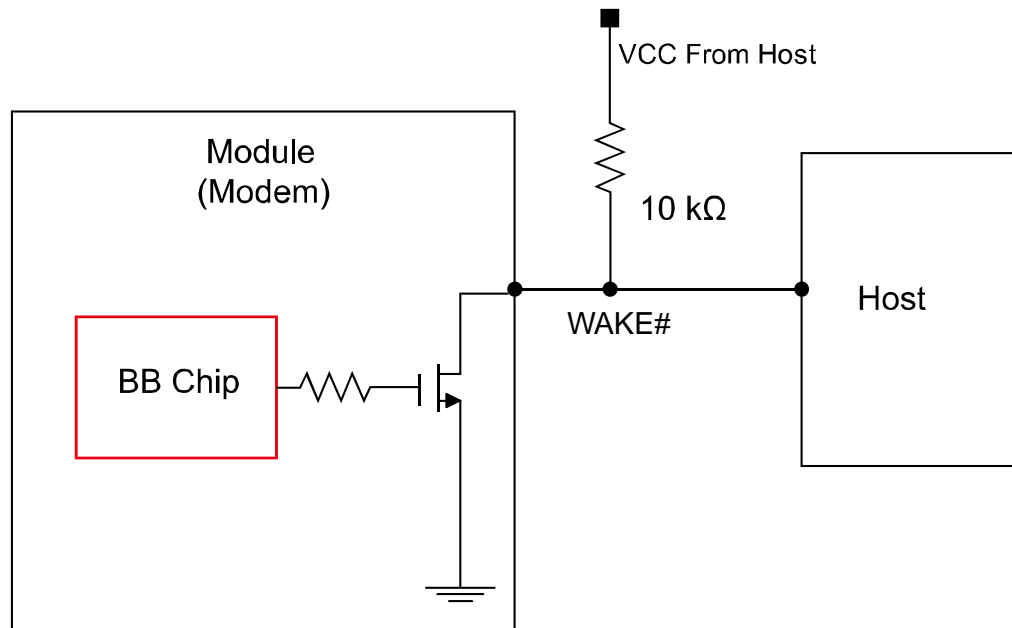

### 3.4.3 RESIN\_N Signal

The RESIN\_N pin is used to reset the module's system. When the module software stops responding, the RESIN\_N pin can be pulled down to reset the module hardware.

The RESIN\_N signal is internally pulled up to 1.8 V, which is automatically on when 3.3 V is applied and it is active-low.

**Figure 3-5** Connections of the RESIN\_N pin

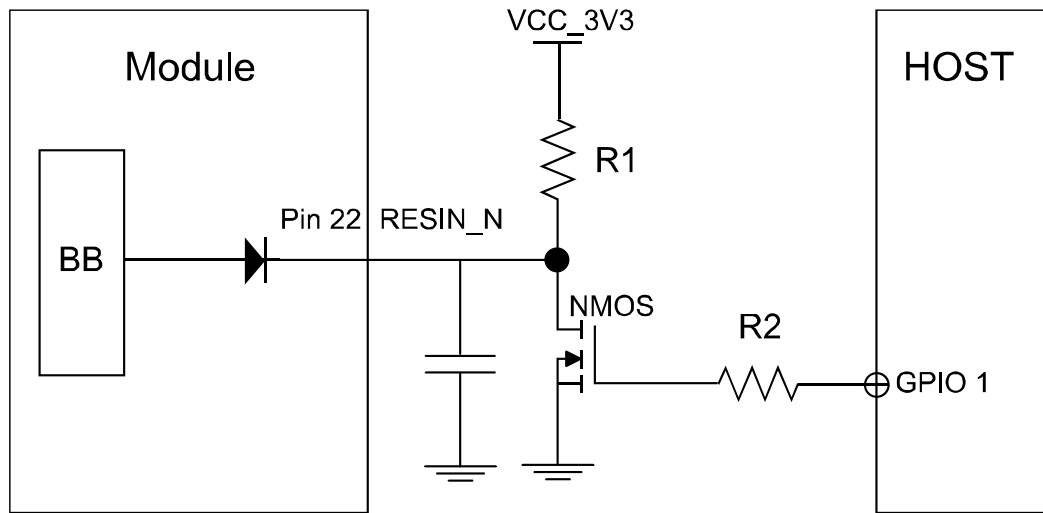

### CAUTION

- As the RESIN\_N signal is relatively sensitive, it is recommended that you install a 10 nF to 0.1  $\mu$ F capacitor near the RESIN\_N pin of the interface for filtering. In addition, when you design a circuit on the PCB of the interface board, it is recommended that the circuit length should not exceed 20 mm and that the circuit should be kept at a distance of 2.54 mm (100 mil) at least from the PCB edge. Furthermore, you need to wrap the area adjacent to the signal wire with a ground wire. Otherwise, the module may be reset due to interference.
- The maximum Forward Voltage Drop of the diode used in the module is 0.6 V. So when the host wants to reset the module, the low-level-voltage in the RESIN\_N pin should be below 50 mV.

The ME909u-521 Mini PCIe module supports hardware reset function. If the software of the ME909u-521 Mini PCIe module stops responding, you can reset the hardware through the RESIN\_N signal as shown in Figure 3-6. When a low-level pulse is supplied through the RESIN\_N pin, the hardware will be reset. After the hardware is reset, the software starts powering on the module and reports relevant information according to the actual settings. For example, the AT command automatically reports ^SYSSTART.

**Figure 3-6** Reset pulse timing

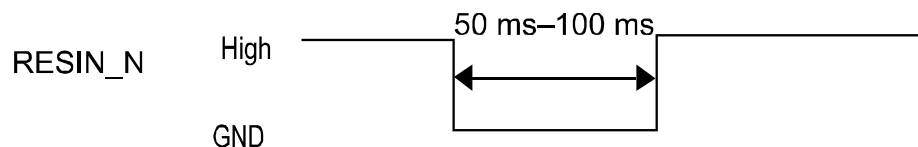



**NOTE**

- The RESIN\_N pin must not be pulled down for more than 1s.
- The RESIN\_N pin is optional, which can be not connected.
- The maximum forward voltage drop of the diode used in the module is 0.6 V.

### 3.4.4 W\_DISABLE# Signal

The W\_DISABLE# signal is provided to allow users to disable wireless communications of the module.

The software version is in plan.

### 3.4.5 LED\_WWAN# Signal

The software feature is under development and do not support this function now.

If you need the LED function, you need reserve circuit and refer to the following figure till the relative firmware is ready.

Figure 3-7 shows the recommended circuits of the LED\_WWAN# pin. According to LED feature, you can adjust the LED brightness by adjusting the resistance of resistor R.

**Figure 3-7** Driving circuit

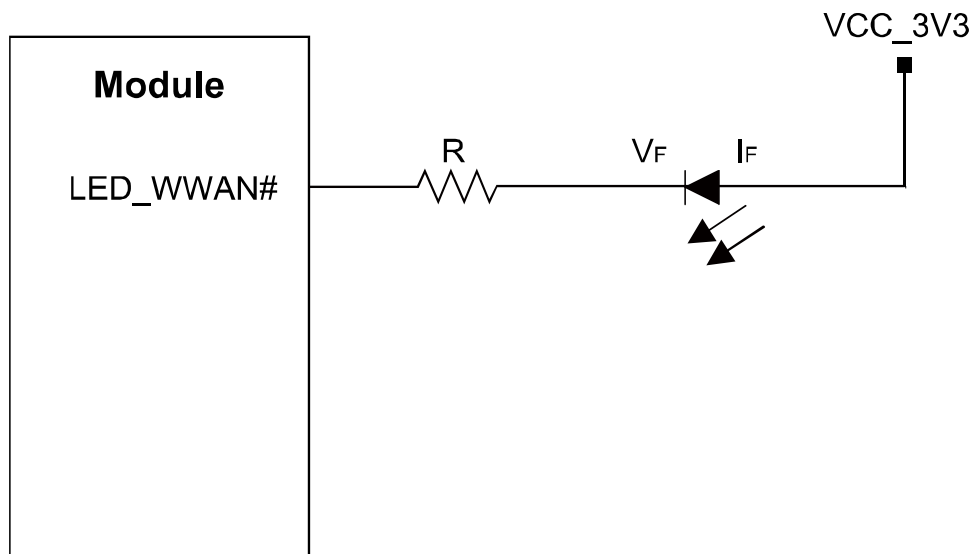

## 3.5 USB Interface

The ME909u-521 Mini PCIe module is compliant with USB 2.0 protocol. The USB interface is powered directly from the VBAT supply. The USB input/output lines are compatible with the USB 2.0 signal specifications. Figure 3-8 shows the circuit of the USB interface.

**Table 3-4** Definition of the USB interface

Pin No.	Pin Name	Pad Type	Description	Parameter	Min. (V)	Typ. (V)	Max. (V)
36	USB_DM	I/O	USB signal D-	-	-	-	-
38	USB_DP	I/O	USB signal D+	-	-	-	-

According to USB protocol, for bus timing or electrical characteristics of ME909u-521 USB signal, please refer to the chapter 7.3.2 of [Universal Serial Bus Specification 2.0](#).

**Figure 3-8** Recommended circuit of USB interface

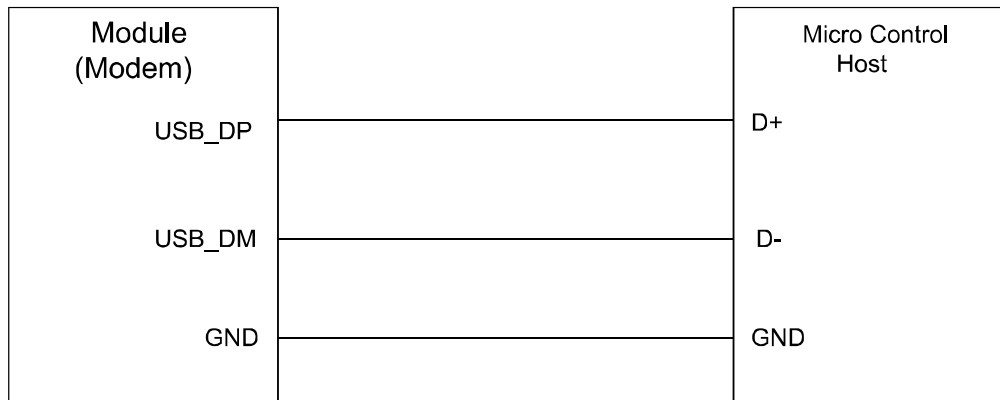

## 3.6 USIM Card Interface

### 3.6.1 Overview

The ME909u-521 Mini PCIe module provides a USIM card interface complying with the ISO 7816-3 standard and supports both Class B and Class C USIM cards.

**Table 3-5** USIM card interface signals

Pin No.	Pin Name	Pad Type	Description	Parameter	Min.(V)	Typ.(V)	Max.(V)
8	USIM_PWR	P	Power source for the external USIM card	-	-	1.8/2.85	-
10	USIM_DATA	I/O	External USIM data signal	-	-	1.8/2.85	-
12	USIM_CLK	O	External USIM clock signal	-	-	1.8/2.85	-

Pin No.	Pin Name	Pad Type	Description	Parameter	Min.(V)	Typ.(V)	Max.(V)
14	USIM_RESET	O	External USIM reset signal	-	-	1.8/2.85	-

### 3.6.2 Circuit Recommended for the USIM Card Interface

As the Mini PCIe Adapter is not equipped with a USIM socket, you need to place a USIM socket on the user interface board.

Figure 3-9 shows the circuit of the USIM card interface.

**Figure 3-9** Circuit of the USIM card interface

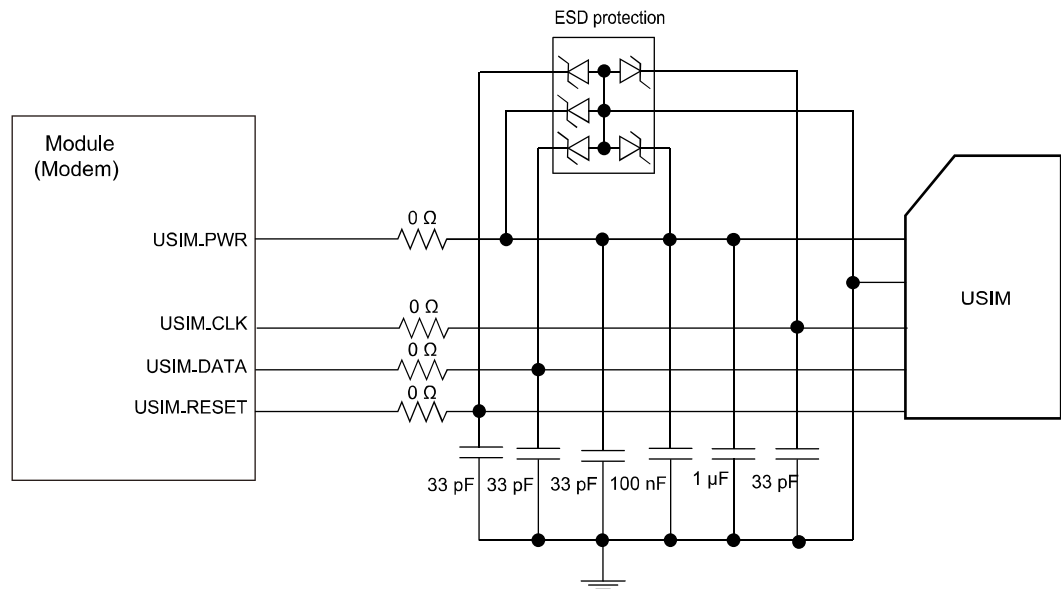



## CAUTION

- To meet the requirements of 3GPP TS 51.010-1 protocols and electromagnetic compatibility (EMC) authentication, the USIM socket should be placed near the PCIe interface (it is recommended that the PCB circuit connects the PCIe interface and the USIM socket does not exceed 100 mm), because a long circuit may lead to wave distortion, thus affecting signal quality.
- It is recommended that you wrap the area adjacent to the USIM\_CLK and USIM\_DATA signal wires with ground. The Ground pin of the USIM socket and the Ground pin of the USIM card must be well connected to the power Ground pin supplying power to the PCIe Adapter.
- A 100 nF capacitor and 1  $\mu$ F capacitor are placed between the USIM\_PWR and GND pins in a parallel manner (If USIM\_PWR circuit is too long, that the larger capacitance such as 4.7  $\mu$ F can be employed if necessary). Three 33 pF capacitors are placed between the USIM\_DATA and Ground pins, the USIM\_RESET and Ground pins, and the USIM\_CLK and Ground pins in parallel to filter interference from RF signals.
- It is recommended to take electrostatic discharge (ESD) protection measures near the USIM card socket. The TVS diode with  $V_{rwm}$  of 5 V and junction capacitance less than 10 pF must be placed as close as possible to the USIM socket, and the Ground pin of the ESD protection component is well connected to the power Ground pin that supplies power to the PCIe Adapter.
- It is not recommended that pull the USIM\_DATA pin up during design as a 10000-ohm resistor is used to connect the USIM\_DATA pin to the USIM\_PWR.

## 3.7 Audio Interface

The ME909u-521 Mini PCIe module provides one PCM digital audio interface. Table 3-6 lists the signals on the digital audio interface.

**Table 3-6** Signals on the digital audio interface

Pin No.	Pin Name	Pad Type	Description	Parameter	Min.(V)	Typ.(V)	Max.(V)
45	PCM_CLK	O	PCM interface clock	$V_{OH}$	1.35	1.8	1.8
				$V_{OL}$	0	-	0.45
47	PCM_DOUT	O	PCM I/F data out	$V_{OH}$	1.35	1.8	1.8
				$V_{OL}$	0	-	0.45
49	PCM_DIN	I	PCM I/F data in	$V_{IH}$	1.17	1.8	2.1
				$V_{IL}$	-0.3	-	0.63
51	PCM_SYNC	O	PCM interface sync	$V_{OH}$	1.35	1.8	1.8
				$V_{OL}$	0	-	0.45

The ME909u-521 Mini PCIe module interface enables communication with an external codec to support linear format.

**Figure 3-10** Circuit diagram of the interface of the PCM (ME909u-521 Mini PCIe module is used as PCM master)

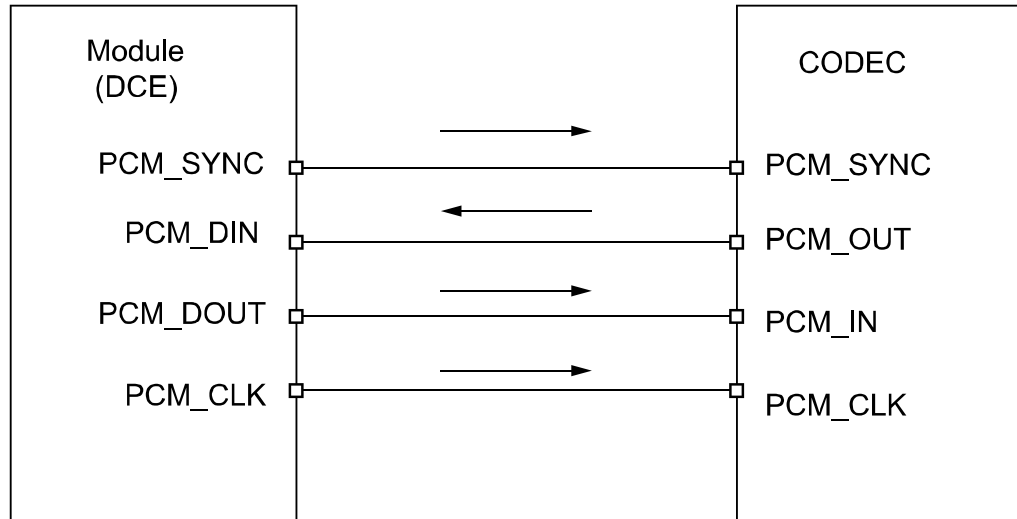

**NOTE**

- The ME909u-521 Mini PCIe module only supports master mode;
- PCM\_SYNC: Output when PCM is in master mode;
- PCM\_CLK: Output when PCM is in master mode;
- It is recommended that a TVS be used on the related interface, to prevent electrostatic discharge and protect integrated circuit (IC) components.

## 3.8 RF Antenna Connector

The ME909u-521 Mini PCIe module provides three antenna connectors (MAIN, GPS and AUX) for connecting the external antennas.

**Figure 3-11** RF antenna connectors

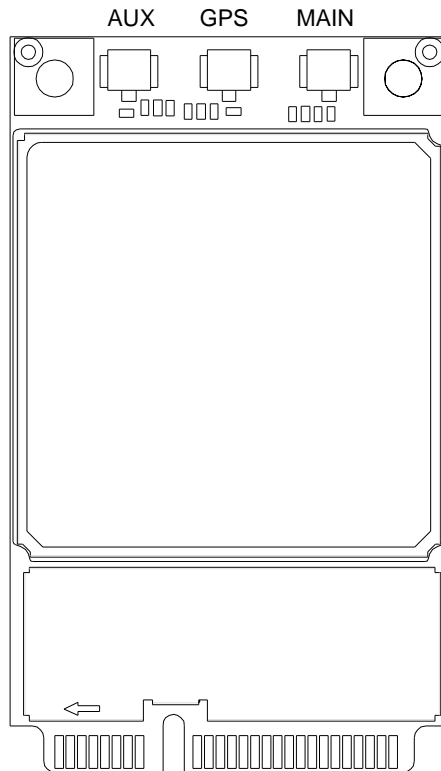

The antenna connectors must be used with coaxial cables with characteristic impedance of 50  $\Omega$ .

### 3.9 Reserved Pins

The ME909u-521 Mini PCIe module provides 2 reserved pins. All of reserved pins cannot be used by the customer.

**Table 3-7** Reserved pins

Pin No.	Pin Name	Pad Type	Description	Parameter	Min. (V)	Typ. (V)	Max. (V)
17 and 19	Reserved	-	Reserved	-	-	-	-

### 3.10 NC Pins

The ME909u-521 Mini PCIe module has some NC pins. All of NC pins should not be connected. Please keep these pins open.



**Table 3-8** NC pins

Pin No.	Pin Name	Pad Type	Description	Parameter	Min. (V)	Typ. (V)	Max. (V)
3, 5-7, 11, 13, 16, 23, 25, 28, 30-33, 44, 46 and 48	NC	-	Not connected, please keep open.	-	-	-	-

# 4 RF Specifications

## 4.1 About This Chapter

This chapter describes the RF specifications of the ME909u-521 Mini PCIe module, including:

- Operating Frequencies
- Conducted RF Measurement
- Conducted Rx Sensitivity and Tx Power
- Antenna Design Requirements
- Co-existence with 5 GHz WIFI Design Guide

## 4.2 Operating Frequencies

Table 4-1 shows the RF bands supported by the ME909u-521 Mini PCIe module.

**Table 4-1** RF bands

Operating Band	Tx	Rx
UMTS Band 1	1920 MHz–1980 MHz	2110 MHz–2170 MHz
UMTS Band 2	1850 MHz–1910 MHz	1930 MHz–1990 MHz
UMTS Band 5	824 MHz–849 MHz	869 MHz–894 MHz
UMTS Band 8	880 MHz–915 MHz	925 MHz–960 MHz
GSM 850	824 MHz–849 MHz	869 MHz–894 MHz
GSM 900	880 MHz–915 MHz	925 MHz–960 MHz
GSM 1800	1710 MHz–1785 MHz	1805 MHz–1880 MHz
GSM 1900	1850 MHz–1910 MHz	1930 MHz–1990 MHz
LTE Band 1	1920 MHz–1980 MHz	2110 MHz–2170 MHz
LTE Band 2	1850 MHz–1910 MHz	1930 MHz–1990 MHz

Operating Band	Tx	Rx
LTE Band 3	1710 MHz–1785 MHz	1805 MHz–1880 MHz
LTE Band 5	824 MHz–849 MHz	869 MHz–894 MHz
LTE Band 8	880 MHz–915 MHz	925 MHz–960 MHz
LTE Band 7	2500 MHz–2570 MHz	2620 MHz–2690 MHz
LTE Band 20	832 MHz–862 MHz	791 MHz–821 MHz
GPS L1	-	1574.42 MHz–1576.42 MHz
GLONASS L1	-	1597.55 MHz–1605.89 MHz

## 4.3 Conducted RF Measurement

### 4.3.1 Test Environment

<b>Test instrument</b>	R&S CMU200, R&S CMW500, Agilent E5515C
<b>Power supply</b>	Keithley 2303, Agilent 66319
<b>RF cable for testing</b>	L08-C014-350 of DRAKA COMTEQ or Rosenberger Cable length: 29 cm



#### NOTE

- The compensation for different frequency bands relates to the cable and the test environment.
- The instrument compensation needs to be set according to the actual cable conditions.

### 4.3.2 Test Standards

Huawei modules meet 3GPP test standards. Each module passes strict tests at the factory and thus the quality of the modules is guaranteed.

## 4.4 Conducted Rx Sensitivity and Tx Power

### 4.4.1 Conducted Receive Sensitivity

The conducted receive sensitivity is a key parameter that indicates the receiver performance of ME909u-521 Mini PCIe module.

Table 4-2 lists the typical Rx sensitivity values of the ME909u-521 Mini PCIe module.

**Table 4-2** Conducted Rx sensitivity

Band	Typical Value (dBm)	Note
GSM 850	-111	BER Class II < 2.44%
GSM 900	-109.5	BER Class II < 2.44%
GSM 1800	-109	BER Class II < 2.44%
GSM 1900	-109	BER Class II < 2.44%
WCDMA Band 1	-110.5	BER < 0.1%
WCDMA Band 2	-109	BER < 0.1%
WCDMA Band 5	-111	BER < 0.1%
WCDMA Band 8	-111	BER < 0.1%
LTE Band 1	-102	Throughput ≥ 95%, 10 MHz Bandwidth
LTE Band 2	-100	Throughput ≥ 95%, 10 MHz Bandwidth
LTE Band 3	-101	Throughput ≥ 95%, 10 MHz Bandwidth
LTE Band 5	-101	Throughput ≥ 95%, 10 MHz Bandwidth
LTE Band 7	-101	Throughput ≥ 95%, 10 MHz Bandwidth
LTE Band 8	-100	Throughput ≥ 95%, 10 MHz Bandwidth
LTE Band 20	-101	Throughput ≥ 95%, 10 MHz Bandwidth

**Table 4-3** ME909u-521 Mini PCIe module GPS main characteristics

Item	Typical Value
Receive Sensitivity (Cold start)	-147 dBm
Receive Sensitivity (Hot start)	-157 dBm
Receive Sensitivity (Tracking mode)	-157 dBm
TTF@-130 dBm (Cold start)	38s
TTF@-130 dBm (Hot start)	2s

 **NOTE**

- The test values are the average of some test samples.
- Sensitivity of WCDMA and GSM are tested in the main port.
- LTE sensitivity is tested in SIMO (Main+AUX).

## 4.4.2 Conducted Transmit Power

The conducted transmit power is another indicator that measures the performance of ME909u-521 Mini PCIe module. The conducted transmit power refers to the maximum power that the module tested at the antenna connector can transmit. According to the 3GPP protocol, the required transmit power varies with the power class.

Table 4-4 lists the typical tested values of the ME909u-521 Mini PCIe module.

**Table 4-4** Conducted Tx power

Band	Typical Value (Unit:dBm)	Note (Unit: dB)
GSM 850	32	+1.5/-1
GSM 900	32	+1.5/-1
DCS1800	29	+1.5/-1
PCS 1900	29	+1.5/-1
WCDMA Band 1	23	+1.5/-1
WCDMA Band 2	23	+1.5/-1
WCDMA Band 5	23	+1.5/-1
WCDMA Band 8	23	+1.5/-1
LTE Band 1	22.5	+1.5/-1
LTE Band 2	22.5	+1.5/-1
LTE Band 3	22.5	+1.5/-1
LTE Band 5	22.5	+1.5/-1
LTE Band 7	22.5	+1.5/-1
LTE Band 8	22.5	+1.5/-1
LTE Band 20	22.5	+1.5/-1

 **NOTE**

Maximum Power Reduction (MPR) of LTE is according to 3GPP TS 36.521-1 as below.

Modulation	RB Allocation	MPR(dB)
QPSK	$\geq 1$ RB; $\leq$ Partial RB	0
QPSK	$>$ Partial RB	$\leq 1$

Modulation	RB Allocation	MPR(dB)
16QAM	$\geq 1$ RB; $\leq$ Partial RB	$\leq 1$
16QAM	$>$ Partial RB	$\leq 2$

## 4.5 Antenna Design Requirements

### 4.5.1 Antenna Design Indicators

#### Antenna Efficiency

Antenna efficiency is the ratio of the input power to the radiated or received power of an antenna. The radiated power of an antenna is always lower than the input power due to the following antenna losses: return loss, material loss, and coupling loss. The efficiency of an antenna relates to its electrical dimensions. To be specific, the antenna efficiency increases with the electrical dimensions. In addition, the transmission cable from the antenna connector of PCIe Adapter to the antenna is also part of the antenna. The cable loss increases with the cable length and the frequency. It is recommended that the cable loss is as low as possible, for example, U.FL-LP-088 made by HRS.

The following antenna efficiency (free space) is recommended for ME909u-521 Mini PCIe module to ensure high radio performance of the module:

- Efficiency of the primary antenna:  $\geq 40\%$  (below 960 MHz);  $\geq 50\%$  (over 1710 MHz)
- Efficiency of the diversity antenna:  $\geq$  half of the efficiency of the primary antenna in receiving band
- Efficiency of the GPS antenna:  $\geq 50\%$

In addition, the efficiency should be tested with the transmission cable.

#### S11 or VSWR

S11 indicates the degree to which the input impedance of an antenna matches the reference impedance ( $50 \Omega$ ). S11 shows the resonance feature and impedance bandwidth of an antenna. Voltage standing wave ratio (VSWR) is another expression of S11. S11 relates to the antenna efficiency. S11 can be measured with a vector analyzer.

The following S11 value is recommended for the antenna of ME909u-521 Mini PCIe module:

- S11 of the primary antenna:  $\leq -6$  dB
- S11 of the diversity antenna:  $\leq -6$  dB
- S11 of the GPS antenna:  $\leq -10$  dB

In addition, S11 is less important than the efficiency, and S11 has weak correlation to wireless performance.

## Isolation

For a wireless device with multiple antennas, the power of different antennas is coupled with each other. Antenna isolation is used to measure the power coupling. The power radiated by an antenna might be received by an adjacent antenna, which decreases the antenna radiation efficiency and affects the running of other devices. To avoid this problem, evaluate the antenna isolation as sufficiently as possible at the early stage of antenna design.

Antenna isolation depends on the following factors:

- Distance between antennas
- Antenna type
- Antenna direction

The primary antenna must be placed as near as possible to the ME909u-521 Mini PCIe module to minimize the cable length. The diversity antenna needs to be installed perpendicularly to the primary antenna. The diversity antenna can be placed farther away from the ME909u-521 Mini PCIe module. Antenna isolation can be measured with a two-port vector network analyzer.

The following antenna isolation is recommended for the antennas on laptops:

- Isolation between the primary and diversity antennas:  $\leq -12$  dB
- Isolation between the primary (diversity) antenna and the GPS antenna:  $\leq -15$  dB
- Isolation between the primary antenna and the Wi-Fi antenna:  $\leq -15$  dB

## Polarization

The polarization of an antenna is the orientation of the electric field vector that rotates with time in the direction of maximum radiation.

The linear polarization is recommended for the antenna of ME909u-521 Mini PCIe module.

## Radiation Pattern

The radiation pattern of an antenna reflects the radiation features of the antenna in the remote field region. The radiation pattern of an antenna commonly describes the power or field strength of the radiated electromagnetic waves in various directions from the antenna. The power or field strength varies with the angular coordinates ( $\theta$  and  $\phi$ ), but is independent of the radial coordinates.

The radiation pattern of half wave dipole antennas is omnidirectional in the horizontal plane, and the incident waves of base stations are often in the horizontal plane. For this reason, the receiving performance is optimal.

The following radiation patterns are recommended for the antenna of ME909u-521 Mini PCIe module.

Primary/Diversity/GPS antenna: omnidirectional

In addition, the diversity antenna's pattern should be complementary with the primary's.

## Envelope Correlation Coefficient

The envelope correlation coefficient indicates the correlation between different antennas in a multi-antenna system (primary antenna, diversity antenna, and MIMO antenna). The correlation coefficient shows the similarity of radiation patterns, that is, amplitude and phase, of the antennas. The ideal correlation coefficient of a diversity antenna system or a MIMO antenna system is 0. A small value of the envelope correlation coefficient between the primary antenna and the diversity antenna indicates a high diversity gain. The envelope correlation coefficient depends on the following factors:

- Distance between antennas
- Antenna type
- Antenna direction

The antenna correlation coefficient differs from the antenna isolation. Sufficient antenna isolation does not represent a satisfactory correlation coefficient. For this reason, the two indicators need to be evaluated separately.

For the antennas on laptops, the recommended envelope correlation coefficient between the primary antenna and the diversity antenna is smaller than 0.5.

## Gain and Directivity

The radiation pattern of an antenna represents the field strength of the radiated electromagnetic waves in all directions, but not the power density that the antenna radiates in the specific direction. The directivity of an antenna, however, measures the power density that the antenna radiates.

Gain, as another important parameter of antennas, correlates closely to the directivity. The gain of an antenna takes both the directivity and the efficiency of the antenna into account. The appropriate antenna gain prolongs the service life of relevant batteries.

The following antenna gain is recommended for ME909u-521 Mini PCIe module.

- Gain of the primary/diversity antenna  $\leq 2.5$  dBi
- Gain of the GPS antenna  $\geq 3$  dBi

### NOTE

- The antenna consists of the antenna body and the relevant RF transmission cable. Take the RF transmission cable into account when measuring any of the preceding antenna indicators.
- Huawei cooperates with various famous antenna suppliers who are able to make suggestions on antenna design, for example, Amphenol, Skycross, etc.

## 4.5.2 Interference

Besides the antenna performance, the interference on the user board also affects the radio performance (especially the TIS) of the module. To guarantee high performance of the module, the interference sources on the user board must be properly controlled.

On the user board, there are various interference sources, such as the LCD, CPU, audio circuits, and power supply. All the interference sources emit interference signals that affect the normal operation of the module. For example, the module sensitivity can be decreased due to interference signals. Therefore, during the design, you need to consider how to reduce the effects of interference sources on the module. You can



take the following measures: Use an LCD with optimized performance; shield the LCD interference signals; shield the signal cable of the board; or design filter circuits.

Huawei is able to make technical suggestions on radio performance improvement of the module.

### 4.5.3 Antenna Requirements

The antenna for ME909u-521 Mini PCIe module must fulfill the following requirements:

Antenna Requirements	
Frequency range	Depending on frequency band(s) provided by the network operator, the customer must use the most suitable antenna for that/those band(s)
Bandwidth of main antenna	70 MHz in GSM 850 80 MHz in GSM 900 170 MHz in GSM 1800 140 MHz in GSM 1900 250 MHz in WCDMA/LTE Band 1 140 MHz in WCDMA/LTE Band 2 70 MHz in WCDMA/LTE Band 5 80 MHz in WCDMA/LTE Band 8 170 MHz in LTE Band 3 190 MHz in LTE Band 7 71 MHz in LTE Band 20
Bandwidth of diversity antenna	60 MHz in WCDMA/LTE Band 1 60 MHz in WCDMA/LTE Band 2 25 MHz in WCDMA/LTE Band 5 35 MHz in WCDMA/LTE Band 8 75 MHz in LTE Band 3 70 MHz in LTE Band 7 30 MHz in LTE Band 20
Bandwidth of GPS antenna	35 MHz in GNSS
Gain	$\leq 2.5$ dBi
Impedance	50 $\Omega$
VSWR absolute max	$\leq 3:1$ ( $\leq 2:1$ for GPS antenna)
VSWR recommended	$\leq 2:1$ ( $\leq 1.5:1$ for GPS antenna)

## 4.6 Co-existence with 5 GHz WIFI Design Guide

### 4.6.1 Purpose

ME909u-521 Mini PCIe module supports LTE Band 1/Band 2/Band 3, GSM 1800 and GSM 1900, and each of that band can generate the 2<sup>nd</sup> or 3<sup>rd</sup> harmonic with the frequency about 5 GHz, so that will deteriorate 5 GHz WIFI receiver performance. That is why Co-existence design needed.

Operating Band	Tx Frequency range (MHz)	2nd order harmonic Fre. Range (MHz)	3rd order harmonic Fre. Range (MHz)	5GHz WIFI Operating Range (MHz)
Band 1 (UMTS, LTE)	1920–1980	3840–3960	5760–5940	4910–5056; 5170–5835
Band 2 (UMTS, LTE), GSM1900	1850–1910	3700–3820	5550–5730	4910–5056; 5170–5835
Band 3 (LTE), GSM1800	1710–1785	3420–3570	5130–5355	4910–5056; 5170–5835

### 4.6.2 Co-existence Design Main Point

#### DC Power for ME909u-521 Mini PCIe module and WIFI Circuit

The suggest DC power tree is shown as below, use LC filter circuit for each branch.

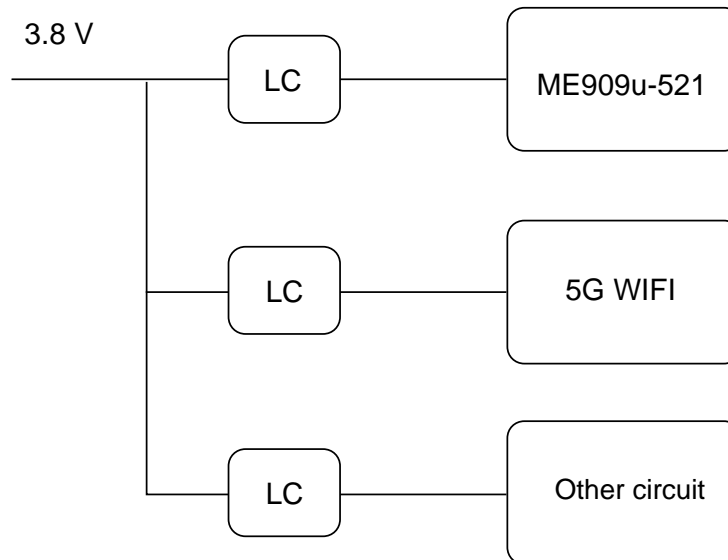

#### RF Front End Design Circuit for ME909u-521 Mini PCIe module

There are low pass filter between module MAIN\_ANT pad and main antenna connector for harmonic filtering. The recommend key electrical specification for LPF and RF front end circuit are respectively listed in Table 4-5 and Figure 4-1

**Table 4-5** The recommend key electrical specification for LPF

Parameter	Frequency (Unit: MHz)	Typical Value (Unit: dB)
Insert loss	300–2690	0.4
Attenuation	4900–5950	35

**Figure 4-1** The recommend RF front end circuit

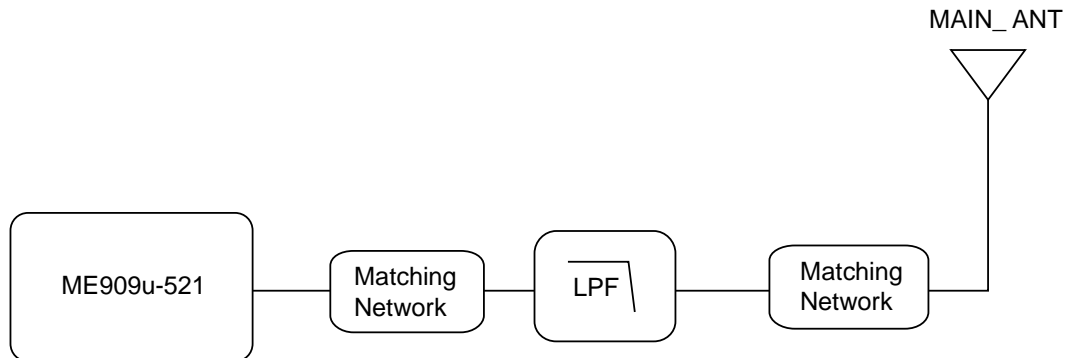

## PCB Placement Suggestion

For PCB placement, we recommend to keep 5 GHz WIFI antenna away from ME909u-521 Mini PCIe module and its main antenna as far as possible.

- The recommend isolation between ME909u-521 Mini PCIe module and WIFI antenna is above 30 dB.
- The recommend isolation between ME909u-521 Mini PCIe antenna and WIFI antenna is above 30 dB.

# 5 Electrical and Reliability Features

## 5.1 About This Chapter

This chapter describes the electrical and reliability features of the interfaces in the ME909u-521 Mini PCIe module, including:

- Absolute Ratings
- Operating and Storage Temperatures
- Power Supply Features
- Reliability Features
- EMC and ESD Features

## 5.2 Absolute Ratings



### WARNING

Table 5-1 lists the absolute ratings for the ME909u-521 Mini PCIe module. Using the module beyond these conditions may result in permanent damage to the module.

**Table 5-1** Absolute ratings for the ME909u-521 Mini PCIe module

Symbol	Specification	Min.	Max.	Unit
VCC_3V3	External power voltage	-0.3	4.0	V
VI	Digital input voltage	-0.3	2.16	V

## 5.3 Operating and Storage Temperatures

Table 5-2 lists the operating and storage temperatures for the ME909u-521 Mini PCIe module.

**Table 5-2** Operating and storage temperatures for the ME909u-521 Mini PCIe module

Specification	Min.	Max.	Unit
Normal working temperature <sup>[1]</sup>	-20	+60	°C
Ambient temperature for storage	-40	+85	°C



**NOTE**

[1]: When the ME909u-521 module works at this temperature, all its RF indexes comply with the 3GPP TS 45.005 and 3GPP TS 34.121-1 specifications.

## 5.4 Power Supply Features

### 5.4.1 Input Power Supply

Table 5-3 lists the requirements for input power of the ME909u-521 Mini PCIe module.

**Table 5-3** Requirements for input power for the ME909u-521 Mini PCIe module

Parameter	Min.	Typ.	Max.	Ripple	Unit
VCC_3V3	3.0	3.3	3.6	0.05	V

**Figure 5-1** Power Supply During Burst Emission

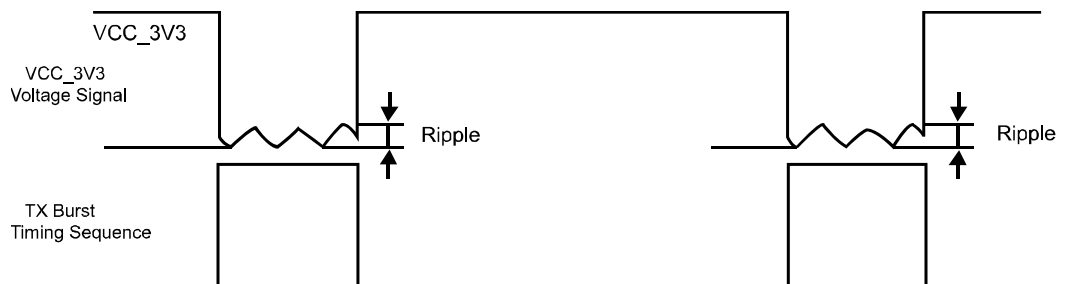

**NOTE**

The VCC\_3V3 minimum value must be guaranteed during the burst (with 3.75 A Peak in GSM 1 slot mode). So a low-dropout (LDO) regulator or switch power with current output of more than 4 A is strongly recommended for external power supply.

**Table 5-4** Requirements for input current of the ME909u-521 Mini PCIe module

Power	Peak (GSM 1 slot)	Normal (WCDMA)	Normal (LTE 23 dbm)
VCC_3V3	3.75 A	1000 mA	1250 mA

## 5.4.2 Power Consumption

The power consumption of ME909u-521 Mini PCIe module in different scenarios are respectively listed in Table 5-5 to Table 5-8 .

The power consumption listed in this section are tested when the power supply of ME909u-521 Mini PCIe module is normal voltage (3.3 V), and all of test values are measured at room temperature.

**Table 5-5** Averaged standby DC power consumption (WCDMA/HSDPA/LTE/GSM)

Description		Bands	Test Value (mA)	Notes/Configuration
			Typical	
Sleep	LTE	LTE bands	5.2	Module is powered up. DRX cycle=8 (2.56s) Module is registered on the network. USB is in suspend.
	HSPA+/WCDMA	UMTS bands	5.3	Module is powered up. DRX cycle=8 (2.56s) Module is registered on the network. USB is in suspend.
	GPRS/EDGE	GSM bands	5.5	Module is powered up. MFRMS=5 (1.175s) Module is registered on the network. USB is in suspend.
Idle	LTE	LTE bands	100	Module is powered up. DRX cycle=8 (2.56s) Module is registered on the network, and no data is transmitted. USB is in active.



Description		Bands	Test Value (mA)	Notes/Configuration
			Typical	
	HSPA+/WCDMA	UMTS bands	110	Module is powered up. DRX cycle=8 (2.56s) Module is registered on the network, and no data is transmitted. USB is in active.
	GPRS/EDGE	GSM bands	94	Module is powered up. MFRMS=5 (1.175s) Module is registered on the network, and no data is transmitted. USB is in active.

**Table 5-6** Averaged data transmission DC power consumption (WCDMA/HSDPA/LTE)

Description	Band	Test Value (mA)	Notes/Configuration
		Typical	
WCDMA	Band 1 (IMT2100)	185	0 dBm Tx Power
		257	10 dBm Tx Power
		975	23.5 dBm Tx Power
	Band 2 (PCS 1900)	188	0 dBm Tx Power
		260	10 dBm Tx Power
		915	23.5 dBm Tx Power
	Band 5 (850 MHz)	160	0 dBm Tx Power
		210	10 dBm Tx Power
		684	23.5 dBm Tx Power
	Band 8 (900 MHz)	155	0 dBm Tx Power
		210	10 dBm Tx Power
		658	23.5 dBm Tx Power
HSDPA	Band 1 (IMT2100)	310	0 dBm Tx Power
		385	10 dBm Tx Power
		985	23.5 dBm Tx Power
	Band 2	303	0 dBm Tx Power



Description	Band	Test Value (mA)	Notes/Configuration
		Typical	
	(PCS 1900)	405	10 dBm Tx Power
		868	23.5 dBm Tx Power
	Band 5 (850 MHz)	258	0 dBm Tx Power
		315	10 dBm Tx Power
		710	23.5 dBm Tx Power
	Band 8 (900 MHz)	365	0 dBm Tx Power
		320	10 dBm Tx Power
		705	23.5 dBm Tx Power
	LTE	Band 1	440
493			10 dBm Tx Power
1240			23 dBm Tx Power
Band 2		426	0 dBm Tx Power
		490	10 dBm Tx Power
		1105	23 dBm Tx Power
Band 3		423	0 dBm Tx Power
		483	10 dBm Tx Power
		1079	23 dBm Tx Power
Band 5		348	0 dBm Tx Power
		390	10 dBm Tx Power
		755	23 dBm Tx Power
Band 7		453	0 dBm Tx Power
		480	10 dBm Tx Power
		835	23 dBm Tx Power
Band 8		357	0 dBm Tx Power
		400	10 dBm Tx Power
		795	23 dBm Tx Power
Band 20		418	0 dBm Tx Power
		590	10 dBm Tx Power
		890	23 dBm Tx Power



**Table 5-7** Averaged DC power consumption (GPRS/EDGE)

Description	Test Value (mA)	PCL	Configuration
	Typical		
GPRS 850	385	5	1 Up/1 Down
	550		2 Up/1 Down
	716		4 Up/1 Down
	168	10	1 Up/1 Down
	275		2 Up/1 Down
	468		4 Up/1 Down
GPRS 900	446	5	1 Up/1 Down
	651		2 Up/1 Down
	860		4 Up/1 Down
	197	10	1 Up/1 Down
	325		2 Up/1 Down
	560		4 Up/1 Down
GPRS 1800	233	0	1 Up/1 Down
	338		2 Up/1 Down
	460		4 Up/1 Down
	85	10	1 Up/1 Down
	115		2 Up/1 Down
	165		4 Up/1 Down
GPRS 1900	247	0	1 Up/1 Down
	385		2 Up/1 Down
	510		4 Up/1 Down
	88	10	1 Up/1 Down
	120		2 Up/1 Down
	170		4 Up/1 Down
EDGE 850	235	8	1 Up/1 Down
	355		2 Up/1 Down
	470		4 Up/1 Down
	110	15	1 Up/1 Down
	170		2 Up/1 Down

Description	Test Value (mA)	PCL	Configuration
	Typical		
	260		4 Up/1 Down
EDGE 900	256	8	1 Up/1 Down
	375		2 Up/1 Down
	505		4 Up/1 Down
	118	15	1 Up/1 Down
	175		2 Up/1 Down
	275		4 Up/1 Down
EDGE 1800	172	2	1 Up/1 Down
	245		2 Up/1 Down
	340		4 Up/1 Down
	86	10	1 Up/1 Down
	115		2 Up/1 Down
	165		4 Up/1 Down
EDGE 1900	188	2	1 Up/1 Down
	270		2 Up/1 Down
	375		4 Up/1 Down
	90	10	1 Up/1 Down
	120		2 Up/1 Down
	175		4 Up/1 Down



**NOTE**

- All the power consumption test configuration can be referenced by GSM Association Official Document TS.09: Battery Life Measurement and Current Consumption Technique.
- LTE test condition: 10/20 MHz bandwidth; QPSK: 1 RB when testing Max. Tx power and full RB when testing 0 dBm or 10 dBm.
- Test condition: for Max. Tx power ,see 4.4.2 Conducted Transmit Power, which are listed in Table 4-4 . data throughput, see 2.2 Function Overview, which are listed in Table 2-1 .

**Table 5-8** Averaged GPS operation DC power consumption

Description	Test Value (mA)	Notes/Configuration
	Typical	
GPS fixing	100	RF is disabled;

Description	Test Value (mA)	Notes/Configuration
	Typical	
GPS tracking	100	USB is in active; The Rx power of GPS is -130 dBm.

## 5.5 Reliability Features

Table 5-9 lists the test conditions and results of the reliability of the ME909u-521 Mini PCIe module.

**Table 5-9** Test conditions and results of the reliability

Item		Test Condition	Standard	Sample size	Results
Stress	Low-temperature storage	<ul style="list-style-type: none"> <li>Temperature: -40°C</li> <li>Operation mode: no power, no package</li> <li>Test duration: 24 h</li> </ul>	JESD22-A119-C	3 pcs/group	Visual inspection: ok Function test: ok RF specification: ok
	High-temperature storage	<ul style="list-style-type: none"> <li>Temperature: 85°C</li> <li>Operation mode: no power, no package</li> <li>Test duration: 24 h</li> </ul>	JESD22-A103-C	3 pcs/group	Visual inspection: ok Function test: ok RF specification: ok
	Low-temperature operating	<ul style="list-style-type: none"> <li>Temperature: -20°C</li> <li>Operation mode: working with service connected</li> <li>Test duration: 24 h</li> </ul>	IEC6006 8-2-1	3 pcs/group	Visual inspection: ok Function test: ok RF specification: ok
	High-temperature operating	<ul style="list-style-type: none"> <li>Temperature: 60°C</li> <li>Operation mode: working with service connected</li> <li>Test duration: 24 h</li> </ul>	JESD22-A108-C	3 pcs/group	Visual inspection: ok Function test: ok RF specification: ok
	Temperature cycle operating	<ul style="list-style-type: none"> <li>High temperature: 60°C</li> <li>Low temperature: -20°C</li> <li>Operation mode: working with service connected</li> <li>Test duration: 30 cycles; 1 h+1 h/cycle</li> </ul>	JESD22-A105-B	3pcs/group	Visual inspection: ok Function test: ok RF specification: ok



Item		Test Condition	Standard	Sample size	Results
	Damp heat cycling	<ul style="list-style-type: none"><li>• High temperature: 55°C</li><li>• Low temperature: 25°C</li><li>• Humidity: 95%±3%</li><li>• Operation mode: working with service connected</li><li>• Test duration: 6 cycles; 12 h+12 h/cycle</li></ul>	JESD22-A101-B	3 pcs/group	Visual inspection: ok Function test: ok RF specification: ok
	Thermal shock	<ul style="list-style-type: none"><li>• Low temperature: -40°</li><li>• High temperature: 85°C</li><li>• Temperature change interval: &lt; 20s</li><li>• Operation mode: no power</li><li>• Test duration: 100 cycles; 15 min+15 min/cycle</li></ul>	JESD22-A106-B	3 pcs/group	Visual inspection: ok Function test: ok RF specification: ok
	Salty fog test	<ul style="list-style-type: none"><li>• Temperature: 35°C</li><li>• Density of the NaCl solution: 5%±1%</li><li>• Operation mode: no power, no package</li><li>• Test duration: Spraying interval: 8 h Exposing period after removing the salty fog environment: 16 h</li></ul>	JESD22-A107-B	3 pcs/group	Visual inspection: ok Function test: ok RF specification: ok
	Sine vibration	<ul style="list-style-type: none"><li>• Frequency range: 5 Hz to 200 Hz</li><li>• Acceleration: 1 Grms</li><li>• Frequency scan rate: 0.5 oct/min</li><li>• Operation mode: working with service connected</li><li>• Test duration: 3 axial directions. 2 h for each axial direction.</li></ul>	JESD22-B103-B	3 pcs/group	Visual inspection: ok Function test: ok RF specification: ok



Item		Test Condition	Standard	Sample size	Results
	Shock test	<ul style="list-style-type: none"><li>• Half-sine wave shock</li><li>• Peak acceleration: 30 Grms</li><li>• Shock duration: 11 ms</li><li>• Operation mode: working with service connected</li><li>• Test duration: 6 axial directions. 3 shocks for each axial direction.</li></ul>	JESD-B1 04-C	3 pcs/group	Visual inspection: ok Function test: ok RF specification: ok
	Drop test	<ul style="list-style-type: none"><li>• 0.8 m in height. Drop the module on the marble terrace with one surface facing downwards, six surfaces should be tested.</li><li>• Operation mode: no power, no package</li></ul>	IEC6006 8-2-32	3 pcs/group	Visual inspection: ok Function test: ok RF specification: ok
Life	High temperature operating life	<ul style="list-style-type: none"><li>• Temperature: 60°C</li><li>• Operation mode: working with service connected</li><li>• Test duration: 168 h, 336 h, 500 h, 1000 h for inspection point</li></ul>	JESD22-A108-B	50 pcs/group	Visual inspection: ok Function test: ok RF specification: ok
	High temperature & high humidity	<ul style="list-style-type: none"><li>• High temperature: 85°C</li><li>• Humidity: 85%</li><li>• Operation mode: powered on and no working</li><li>• Test duration: 168 h, 336 h, 500 h, 1000 h for inspection point</li></ul>	JESD22-A110-B	50 pcs/group	Visual inspection: ok Function test: ok RF specification: ok Cross section: ok
	Temperature cycle-Non operating	<ul style="list-style-type: none"><li>• High temperature: 85°C</li><li>• Low temperature: -40°C</li><li>• Temperature change slope: 6°C/min</li><li>• Operation mode: no power</li><li>• Test duration: 168 h, 336 h, 500 h, 1000 h for inspection point</li></ul>	JESD22-A104-C	50 pcs/group	Visual inspection: ok Function test: ok RF specification: ok Cross section: ok
ESD	HBM (Human Body Model)	<ul style="list-style-type: none"><li>• 1 kV (Class 1 B)</li><li>• Operation mode: no power</li></ul>	JESD22-A114-D	3 pcs/group	Visual inspection: ok Function test: ok RF specification: ok

Item		Test Condition	Standard	Sample size	Results
	ESD with DVK (or embedded in the host)	<ul style="list-style-type: none"> <li>• Contact Voltage: <math>\pm 2</math> kV, <math>\pm 4</math> kV</li> <li>• Air Voltage : <math>\pm 2</math> kV, <math>\pm 4</math> kV, <math>\pm 8</math> kV</li> <li>• Operation mode: working with service connected</li> </ul>	IEC6100 0-4-2	2 pcs	Visual inspection: ok Function test: ok RF specification: ok
 <b>NOTE</b> Groups $\geq 2$					

## 5.6 EMC and ESD Features

The following are the EMC design comments:

- Attention should be paid to static control in the manufacture, assembly, packaging, handling and storage process to reduce electrostatic damage to HUAWEI module.
- RSE (Radiated Spurious Emission) may exceed the limit defined by EN301489 if the antenna port is protected by TVS (Transient Voltage Suppressor), which is resolved by making some adjustment on RF match circuit.
- TVS should be added on the USB port for ESD protection, and the parasitic capacitance of TVS on D+/D- signal should be less than 2 pF. Common-mode inductor should be added in parallel on D+/D- signal.
- TVS should be added on the SIM interface for ESD protection. The parasitic capacitance of TVS on USIM signal should be less than 10 pF;
- Resistors in parallel and a 10nF capacitance should be added on RESIN\_N signal to avoid shaking, and the distance between the capacitor and the related pins should be less than 100 mil.
- PCB routing should be V-type rather than T-type for TVS.
- An integrated ground plane is necessary for EMC design.

The following are the requirements of ESD environment control:

- The electrostatic discharge protected area (EPA) must have an ESD floor whose surface resistance and system resistance are greater than  $1 \times 10^4 \Omega$  while less than  $1 \times 10^9 \Omega$ .
- The EPA must have a sound ground system without loose ground wires, and the ground resistance must be less than 4  $\Omega$ .
- The workbench for handling ESD sensitive components must be equipped with common ground points, the wrist strap jack, and ESD pad. The resistance between the jack and common ground point must be less than 4  $\Omega$ . The surface resistance and system resistance of the ESD pad must be less than  $1 \times 10^9 \Omega$ .
- The EPA must use the ESD two-circuit wrist strap, and the wrist strap must be connected to the dedicated jack. The crocodile clip must not be connected to the ground.

- The ESD sensitive components, the processing equipment, test equipment, tools, and devices must be connected to the ground properly. The indexes are as follows:
  - Hard ground resistance  $< 4 \Omega$
  - $1 \times 10^5 \Omega \leq$  Soft ground resistance  $< 1 \times 10^9 \Omega$
  - $1 \times 10^5 \Omega \leq$  ICT fixture soft ground resistance  $< 1 \times 10^{11} \Omega$
  - The electronic screwdriver and electronic soldering iron can be easily oxidized. Their ground resistance must be less than  $20 \Omega$ .
- The parts of the equipment, devices, and tools that touch the ESD sensitive components and moving parts that are close to the ESD sensitive components must be made of ESD materials and have sound ground connection. The parts that are not made of ESD materials must be handled with ESD treatment, such as painting the ESD coating or ionization treatment (check that the friction voltage is less than 100 V).
- Key parts in the production equipment (parts that touch the ESD sensitive components or parts that are within 30 cm away from the ESD sensitive components), including the conveyor belt, conveyor chain, guide wheel, and SMT nozzle, must all be made of ESD materials and be connected to the ground properly (check that the friction voltage is less than 100 V).
- Engineers that touch IC chips, boards, modules, and other ESD sensitive components and assemblies must wear ESD wrist straps, ESD gloves, or ESD finger cots properly. Engineers that sit when handling the components must all wear ESD wrist straps.
- Noticeable ESD warning signs must be attached to the packages and placement areas of ESD sensitive components and assemblies.
- Boards and IC chips must not be stacked randomly or be placed with other ESD components.
- Effective shielding measures must be taken on the ESD sensitive materials that are transported or stored outside the EPA.

**NOTE**

ME909u-521 Mini PCIe module does not include any protection against overvoltage.

# 6 Mechanical Specifications

---

## 6.1 About This Chapter

This chapter mainly describes mechanical specifications of ME909u-521 Mini PCIe module, including:

- Dimensions and Interfaces
- Dimensions of the Mini PCI Express Connector
- Packaging
- Label
- Specification Selection for Fasteners
- Antenna Plug
- Thermal Design Guide

## 6.2 Dimensions and Interfaces

The dimensions (L × W × H) of the ME909u-521 Mini PCIe module are 51 mm × 30.4 mm × 3.35 mm. Figure 6-1 shows the dimensions of ME909u-521 Mini PCIe module in detail.

**Figure 6-1** Dimensions of the ME909u-521 Mini PCIe module (Unit: mm)

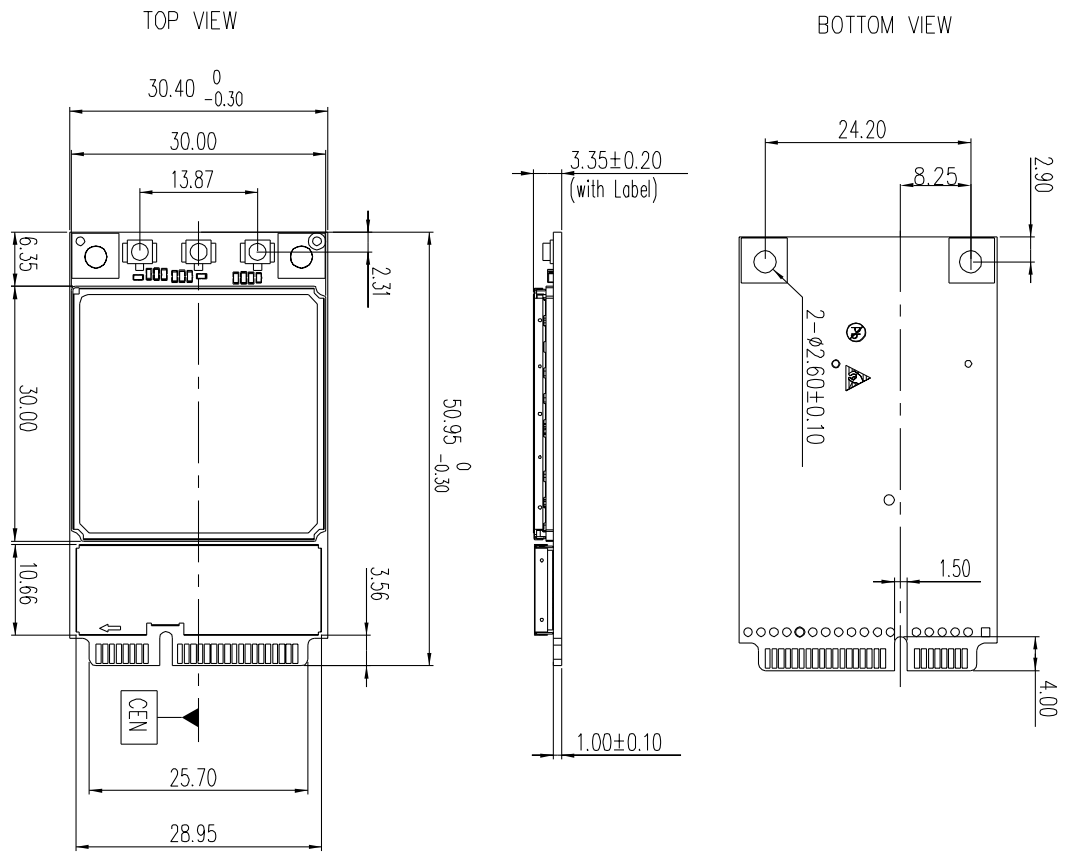

## 6.3 Dimensions of the Mini PCI Express Connector

The Mini PCIe Adapter adopts a standard Mini PCI Express connector that has 52 pins and complies with the [PCI Express Mini Card Electromechanical Specification Revision 1.2](#).

Figure 6-2 shows a 52-pin Mini PCI Express connector (take the Molex 67910002 as an example).

**Figure 6-2** Dimensions of the Mini PCI Express connector (Unit: mm)

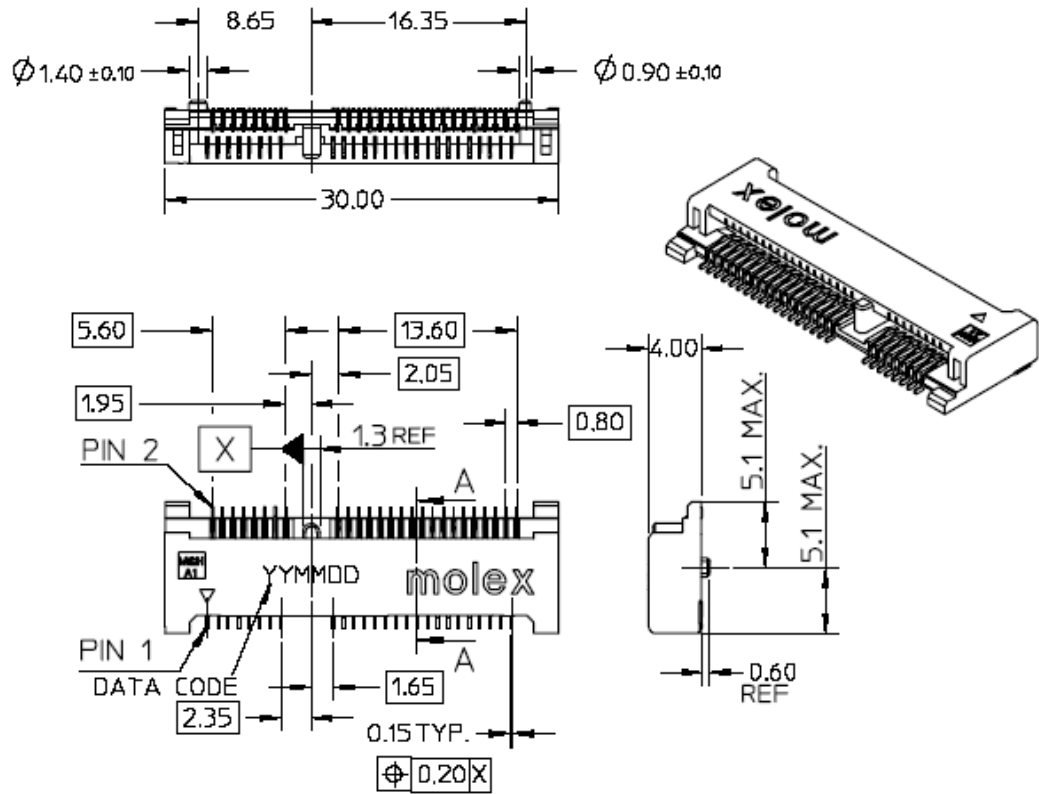

## 6.4 Packaging

HUAWEI Mini PCIe module uses anti-vibration foam and ESD bag into cartons.

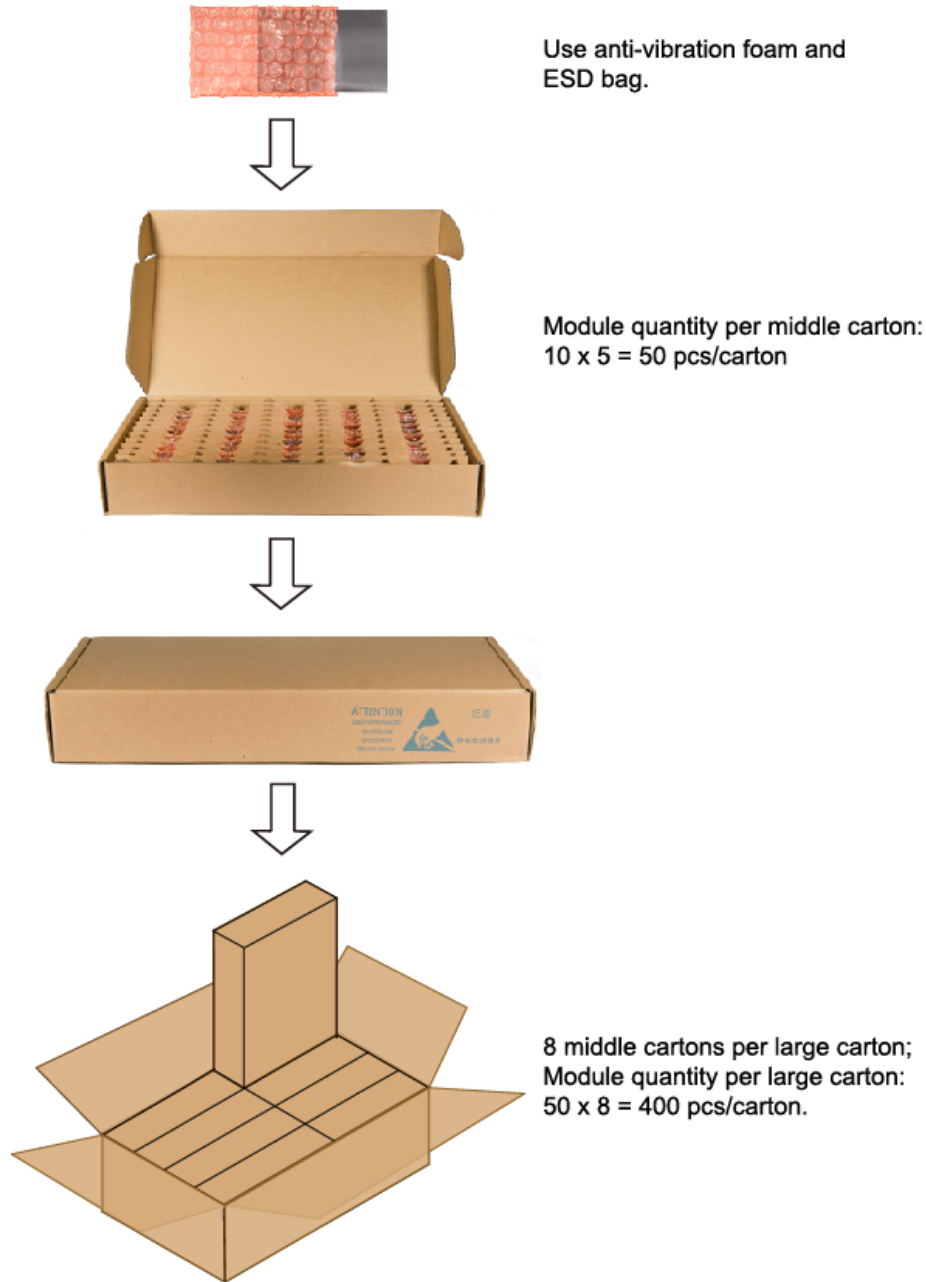

## 6.5 Label

The label is made from fade-resistant material.

Figure 6-3 ME909u-521 Mini PCIe module label

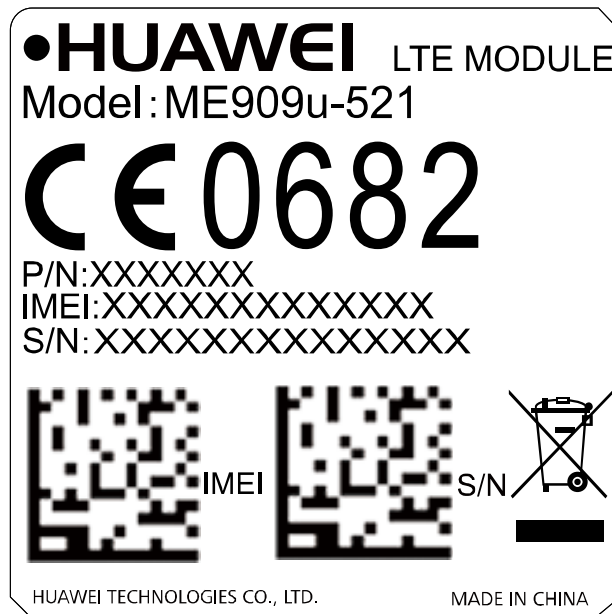

**NOTE**

The picture mentioned above is only for reference.

## 6.6 Specification Selection for Fasteners

### 6.6.1 Installing the Mini PCIe Adapter on the Main Board

To install the Mini PCIe Adapter on the main board, do the following:

- Step 1 Insert the Mini PCIe Adapter into the Mini PCI Express connector on the main board.

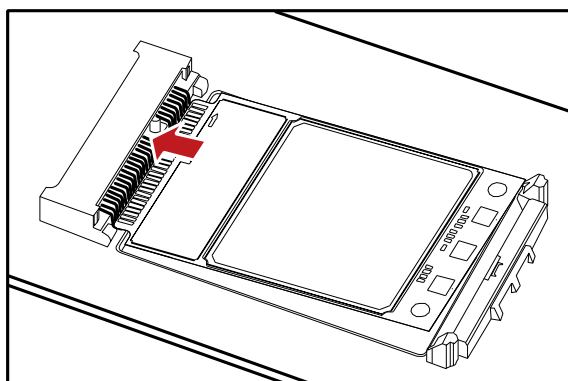

- Step 2 Press downwards to fix the Mini PCIe Adapter in the module slot.

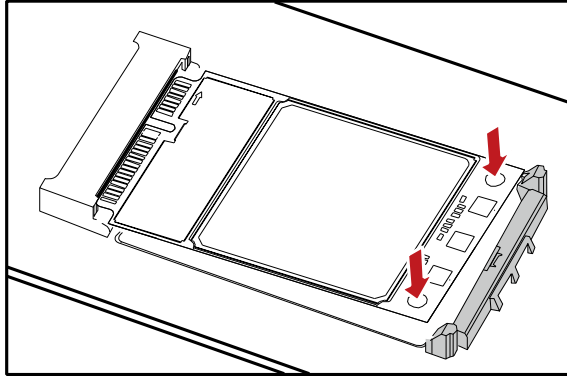

Step 3 Use a screwdriver to fix the Mini PCIe Adapter on the main board with two screws provided in the Mini PCIe Adapter packing box.

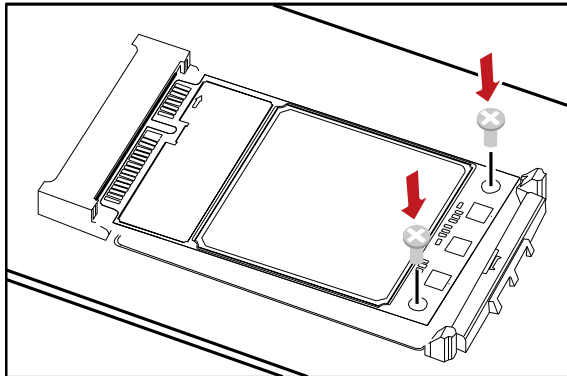

Step 4 Insert the connector of the main antenna into the MAIN antenna interface (M) of the Mini PCIe Adapter according to the indication on the label of the Mini PCIe Adapter. Insert the connector of the auxiliary antenna into the AUX antenna interface (A) of the Mini PCIe Adapter and the GPS antenna into the GPS antenna interface (G) of the Mini PCIe Adapter in the same way.

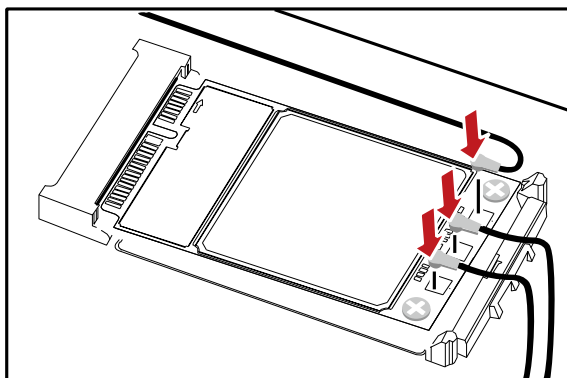

 **NOTE**

- Insert the antenna connectors vertically into the antenna interfaces of the Mini PCIe Adapter.
- Do not press or squeeze the antenna cable or damage the connectors. Otherwise, the wireless performance of the Mini PCIe Adapter may be reduced or the Mini PCIe Adapter cannot work normally.
- Ensure that the antenna cables are routed through the channel in the frame of the PC and do not lay the cables across the raised edges of the frame.
- The module could not be installed or removed when the host is powered on. Otherwise, it may result in permanent damage to the module.

## 6.6.2 Removing the Mini PCIe Adapter from the Main Board

Step 1 Disconnect the antenna cables from the Mini PCIe Adapter. You can lift the connectors using a small screwdriver.

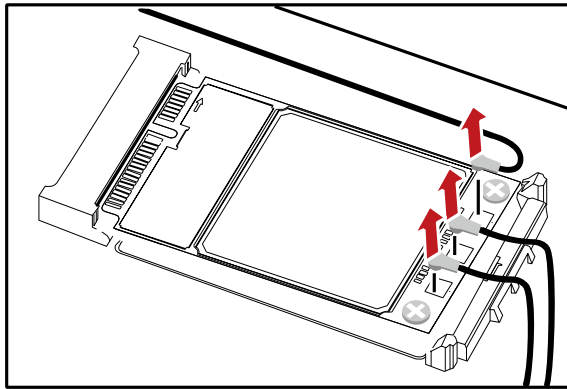

Step 2 Remove the two screws with the screwdriver.

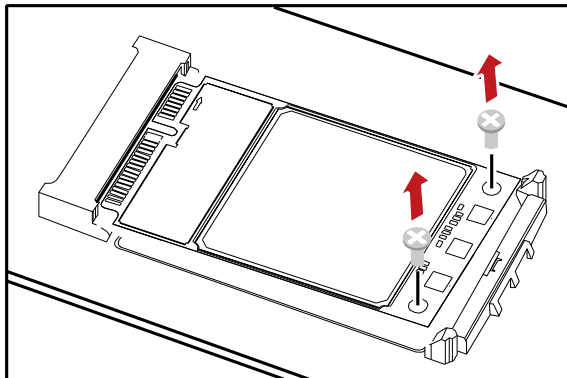

Step 3 Slide backwards the two clips to release the Mini PCIe Adapter from the slot. Then, lift up the Mini PCIe Adapter.

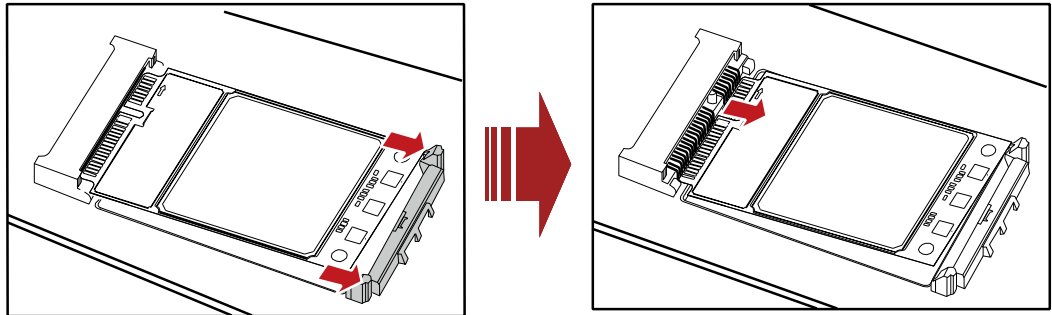

## 6.7 Antenna Plug

**Figure 6-4** Mating the plug

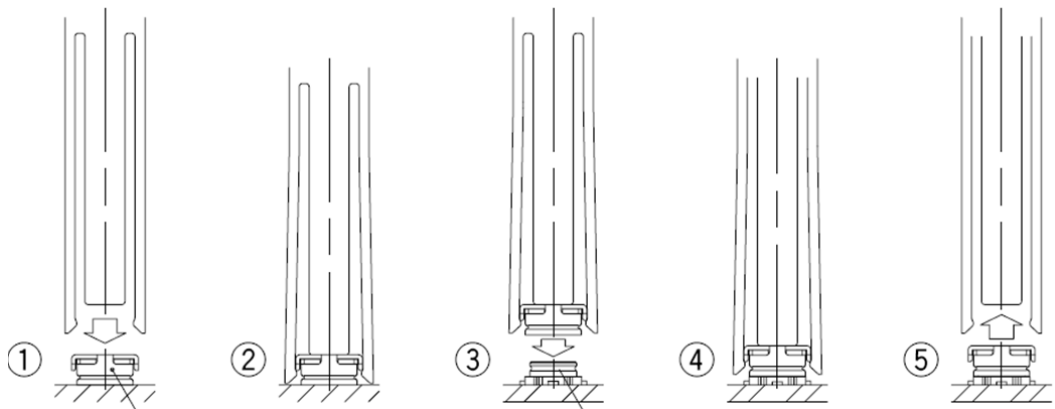

1. Align the mating tool or the mating end of the tool over the plug end of the cable assembly.
2. Firmly place the tool over the plug until it is secured in the tool.
3. Place the plug cable assembly (held in the tool) over the corresponding receptacle.
4. Assure that the plug and receptacle are aligned press-down perpendicular to the mounting surface until both connectors are fully mated.
5. Remove the mating tool by pulling it up carefully.

**Figure 6-5** Unmating the plug

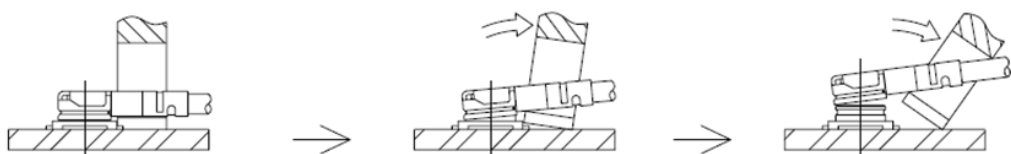

 **NOTE**

- The extraction tool is recommended.
- Any attempt of unmating by pulling on the cable may result in damage and influence the mechanical/electrical performance.

It is recommended not to apply any pull forces after the bending of the cable, as described in Figure 6-6 .

**Figure 6-6** Do not apply any pull forces after the bending of the cable

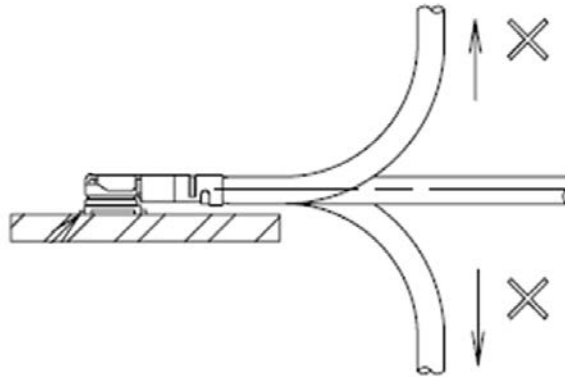

## 6.8 Thermal Design Guide

When using in the LTE network, the Mini PCIe has high power consumption (for details, see Table 5-6 ). To improve the module reliability and stability, focus on the thermal design of the device to speed up heat dissipation.

Take the following heat dissipation measures:

- Do not hollow out the customer PCB.
- Attach the thermal conductive material between the Mini PCIe and the customer PCB. The recommended thermal conductivity of the thermal conductive material is 1.0 W/m-k or higher (recommended manufacturers: Laird and Bergquist). The dimensions (W x D) of the thermal conductive material are 38 mm x 28 mm (1.50 in. x 1.10 in.), and its height depends on the height of the Mini PCIe connector you use and the method for installing the Mini PCIe. When deciding the height of the thermal conductive material, you are advised to obey the following rule: After the Mini PCIe is fastened to the customer PCB, the compression amount of the thermal conductive material accounts for 15% to 30% of the thermal conductive material size. For example, if you use a connector shown in the following figure and install the Mini PCIe like this, the recommended height of the thermal conductive material is 1.8 mm (0.07 in.).

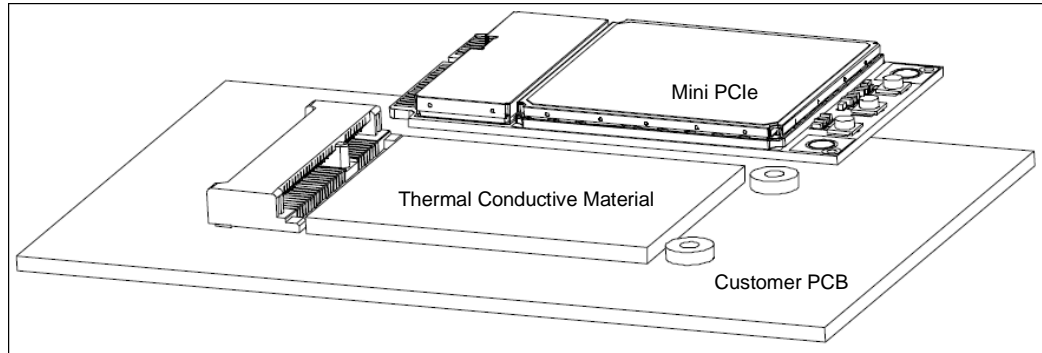

- On the customer PCB, reserve two metal screw holes, which are connected to the PCB ground plane. When installing the Mini PCIe, use two metal screws to fasten the Mini PCIe to the customer PCB. See the following figure.

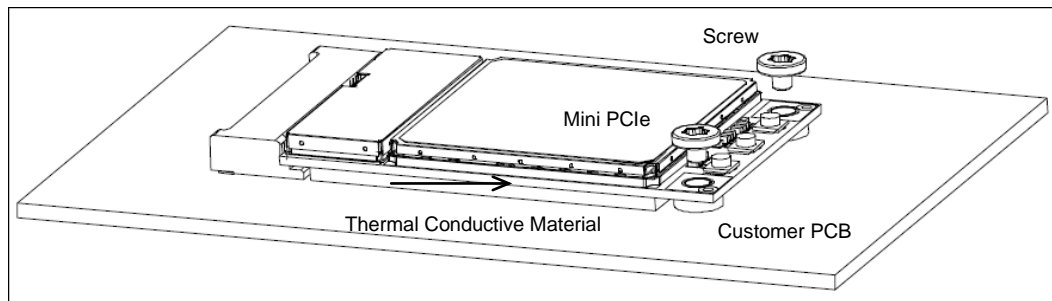

- Ensure that the air flow around the Mini PCIe is sufficient.
- Try not to place any component in the Mini PCIe's projection region on the customer PCB. Do not place components with 1.5 W or higher power consumption or heat sensitive components (such as crystals) near the Mini PCIe.
- Use a large customer PCB. The recommended size (W x D) is 80 mm x 80 mm (3.15 in. x 3.15 in.).
- Apply copper to the region for attaching the thermal conductive material to the customer PCB. Try to use the continuous ground plane design on the customer PCB, and each ground plane must be connected through holes. Therefore, reserve holes as many as possible.



**NOTE**

If you do not take the preceding heat dissipation measures, the overheat protection mechanism is triggered due to overheated Mini PCIe and the network connection is terminated when the Mini PCIe keeps working in enclosed space with a 60°C temperature and a current of more than 820 mA for a period of time. You can resume the network connection only after the temperature drops.

# 7 Certifications

## 7.1 About This Chapter

This chapter gives a general description of certifications of ME909u-521 Mini PCIe module.

## 7.2 Certifications

**NOTE**

Table 7-1 shows certifications the ME909u-521 Mini PCIe module has been implemented. For more demands, please contact us for more details about this information.

**Table 7-1** Product Certifications

Certification	Model name
	ME909u-521
CE	√
RoHS	√
WEEE	√

# 8 Safety Information

---

Read the safety information carefully to ensure the correct and safe use of your wireless device. Applicable safety information must be observed.

## 8.1 Interference

Power off your wireless device if using the device is prohibited. Do not use the wireless device when it causes danger or interference with electric devices.

## 8.2 Medical Device

- Power off your wireless device and follow the rules and regulations set forth by the hospitals and health care facilities.
- Some wireless devices may affect the performance of the hearing aids. For any such problems, consult your service provider.
- Pacemaker manufacturers recommend that a minimum distance of 15 cm be maintained between the wireless device and a pacemaker to prevent potential interference with the pacemaker. If you are using an electronic medical device, consult the doctor or device manufacturer to confirm whether the radio wave affects the operation of this device.

## 8.3 Area with Inflammables and Explosives

To prevent explosions and fires in areas that are stored with inflammable and explosive devices, power off your wireless device and observe the rules. Areas stored with inflammables and explosives include but are not limited to the following:

- Gas station
- Fuel depot (such as the bunk below the deck of a ship)
- Container/Vehicle for storing or transporting fuels or chemical products
- Area where the air contains chemical substances and particles (such as granule, dust, or metal powder)
- Area indicated with the "Explosives" sign



- Area indicated with the "Power off bi-direction wireless equipment" sign
- Area where you are generally suggested to stop the engine of a vehicle

## 8.4 Traffic Security

- Observe local laws and regulations while using the wireless device. To prevent accidents, do not use your wireless device while driving.
- RF signals may affect electronic systems of motor vehicles. For more information, consult the vehicle manufacturer.
- In a motor vehicle, do not place the wireless device over the air bag or in the air bag deployment area. Otherwise, the wireless device may hurt you owing to the strong force when the air bag inflates.

## 8.5 Airline Security

Observe the rules and regulations of airline companies. When boarding or approaching a plane, power off your wireless device. Otherwise, the radio signal of the wireless device may interfere with the plane control signals.

## 8.6 Safety of Children

Do not allow children to use the wireless device without guidance. Small and sharp components of the wireless device may cause danger to children or cause suffocation if children swallow the components.

## 8.7 Environment Protection

Observe the local regulations regarding the disposal of your packaging materials, used wireless device and accessories, and promote their recycling.

## 8.8 WEEE Approval

The wireless device is in compliance with the essential requirements and other relevant provisions of the Waste Electrical and Electronic Equipment Directive 2012/19/EU (WEEE Directive).

## 8.9 RoHS Approval

The wireless device is in compliance with the restriction of the use of certain hazardous substances in electrical and electronic equipment Directive 2011/65/EU (RoHS Directive).



## 8.10 Laws and Regulations Observance

Observe laws and regulations when using your wireless device. Respect the privacy and legal rights of the others.

## 8.11 Care and Maintenance

It is normal that your wireless device gets hot when you use or charge it. Before you clean or maintain the wireless device, stop all applications and power off the wireless device.

- Use your wireless device and accessories with care and in clean environment. Keep the wireless device from a fire or a lit cigarette.
- Protect your wireless device and accessories from water and vapour and keep them dry.
- Do not drop, throw or bend your wireless device.
- Clean your wireless device with a piece of damp and soft antistatic cloth. Do not use any chemical agents (such as alcohol and benzene), chemical detergent, or powder to clean it.
- Do not leave your wireless device and accessories in a place with a considerably low or high temperature.
- Use only accessories of the wireless device approved by the manufacture. Contact the authorized service center for any abnormality of the wireless device or accessories.
- Do not dismantle the wireless device or accessories. Otherwise, the wireless device and accessories are not covered by the warranty.
- The device should be installed and operated with a minimum distance of 20 cm between the radiator and your body.

## 8.12 Emergency Call

This wireless device functions through receiving and transmitting radio signals. Therefore, the connection cannot be guaranteed in all conditions. In an emergency, you should not rely solely on the wireless device for essential communications.

## 8.13 Regulatory Information

The following approvals and notices apply in specific regions as noted.

### 8.13.1 CE Approval (European Union)

The wireless device is approved to be used in the member states of the EU. The wireless device is in compliance with the essential requirements and other relevant provisions of the Radio and Telecommunications Terminal Equipment Directive 1999/5/EC (R&TTE Directive).

# 9 Appendix A Circuit of Typical Interface

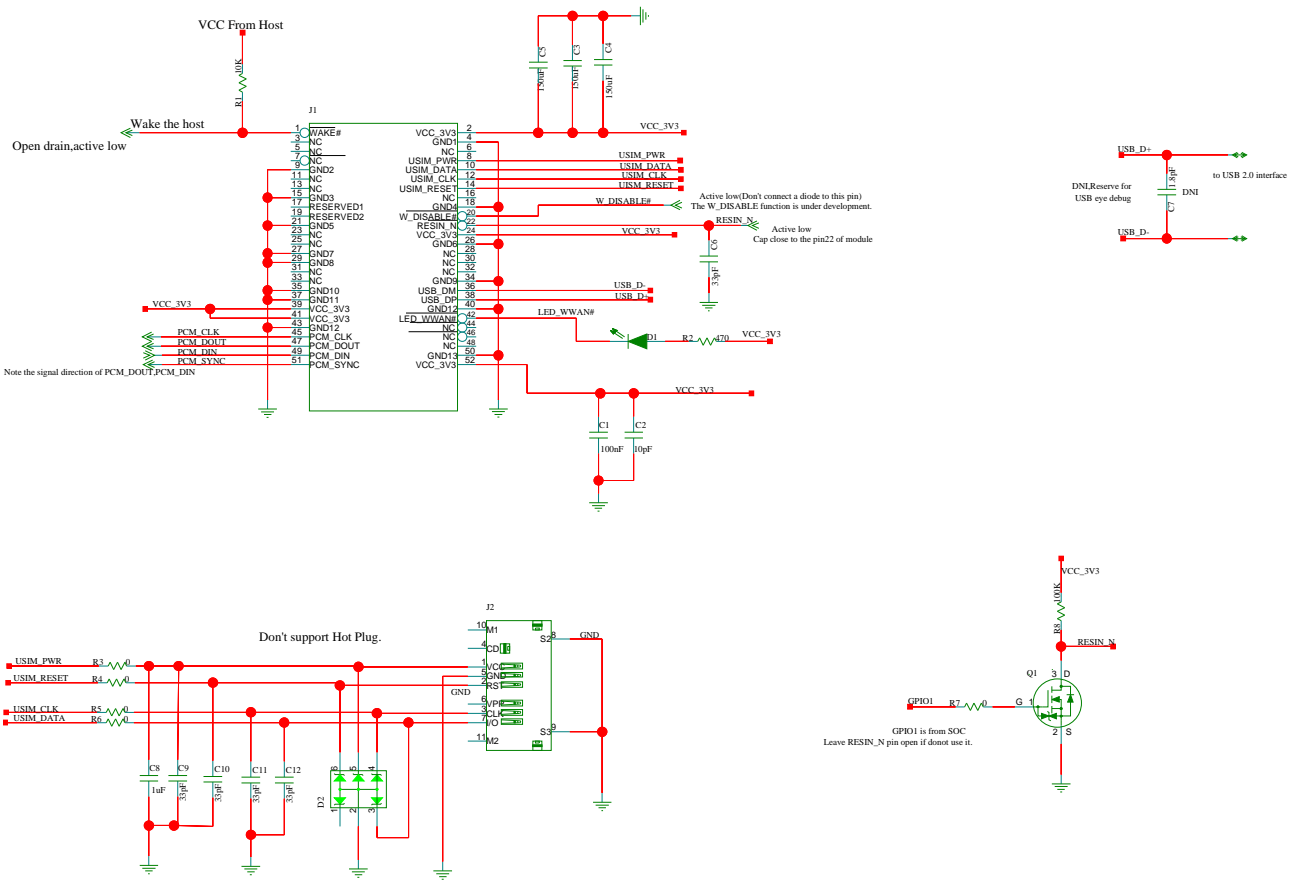

# 10

## Appendix B Acronyms and Abbreviations

Acronym or Abbreviation	Expansion
3GPP	Third Generation Partnership Project
8PSK	8 Phase Shift Keying
AUX	Auxiliary
BER	Bit Error Rate
BIOS	Basic Input Output System
BLER	Block Error Rate
CCC	China Compulsory Certification
CE	European Conformity
CS	Coding Scheme
CSD	Circuit Switched Data
DC	Direct Current
DCE	Data Communication Equipment
EMC	Electromagnetic Compatibility
ESD	Electrostatic Discharge
EU	European Union
FCC	Federal Communications Commission
GPIO	General-purpose I/O
GPRS	General Packet Radio Service
GSM	Global System for Mobile Communication
HBM	Human Body Model



Acronym or Abbreviation	Expansion
HSDPA	High-Speed Downlink Packet Access
HSPA+	Enhanced High Speed Packet Access
HSUPA	High Speed Up-link Packet Access
ISO	International Standards Organization
LCP	Liquid Crystal Polyester
LDO	Low-Dropout
LED	Light-Emitting Diode
LGA	Land Grid Array
LTE	Long Term Evolution
MCP	Multi-chip Package
PCB	Printed Circuit Board
RF	Radio Frequency
RoHS	Restriction of the Use of Certain Hazardous Substances
TBD	To Be Determined
TTF	Time to First Fix
TVS	Transient Voltage Suppressor
UMTS	Universal Mobile Telecommunications System
USB	Universal Serial Bus
USIM	Universal Subscriber Identity Module
VSWR	Voltage Standing Wave Ratio
WCDMA	Wideband Code Division Multiple Access
WEEE	Waste Electrical and Electronic Equipment