

Hubbell Industrial Controls, Inc.

A subsidiary of Hubbell Incorporated

50 Edwards St.

Madison, OH 44057



Telephone (440) 428-1161

FAX (440) 428-7635

Instruction Manual

Fire Pump Controller

Model LX-1500

Limited Service

Electric

Publication No. 197

April, 2000

Table of Contents

I Introduction.....3
II Specifications and Certifications3
 Specifications 3
 Certifications 4
III Receiving, Handling, and Storage.....4
IV Installation4
V Sequence of Operation5
VI Start Up Procedure.....7
VII Maintenance9
 Preventive Maintenance..... 9
 Troubleshooting..... 9
 Coil and Contact Replacement..... 10
VIII Limited Service Fire Pump Controller Parts..... 11

Attachments

- Typical Controller Schematic
- Typical Field Connection Diagram

Notes

Refer to job drawings for options.
For combination Automatic Transfer Switch/Fire Pump Controller applications, refer to Publication No. 186 for the LX-250 Transfer Switch or Publication No. 195 for the LX-350 Transfer Switch, for details.

I Introduction

The Hubbell Limited Service Fire Pump Controller provides automatic and manual control of small electric motor driven fire pumps and booster pumps of 30 horsepower or less.

All Controller components are inside the cabinet with indicating lights and switch handles located next to the door. A pressure switch initiates automatic starting of the pump motor. The Controller monitors the power phases and voltage. The **CIRCUIT BREAKER DISCONNECTING MEANS** handle has a door interlock feature to prevent opening the door when the switch is closed. The Controller also has an **EMERGENCY MANUAL CONTROL** handle to start the fire pump manually.

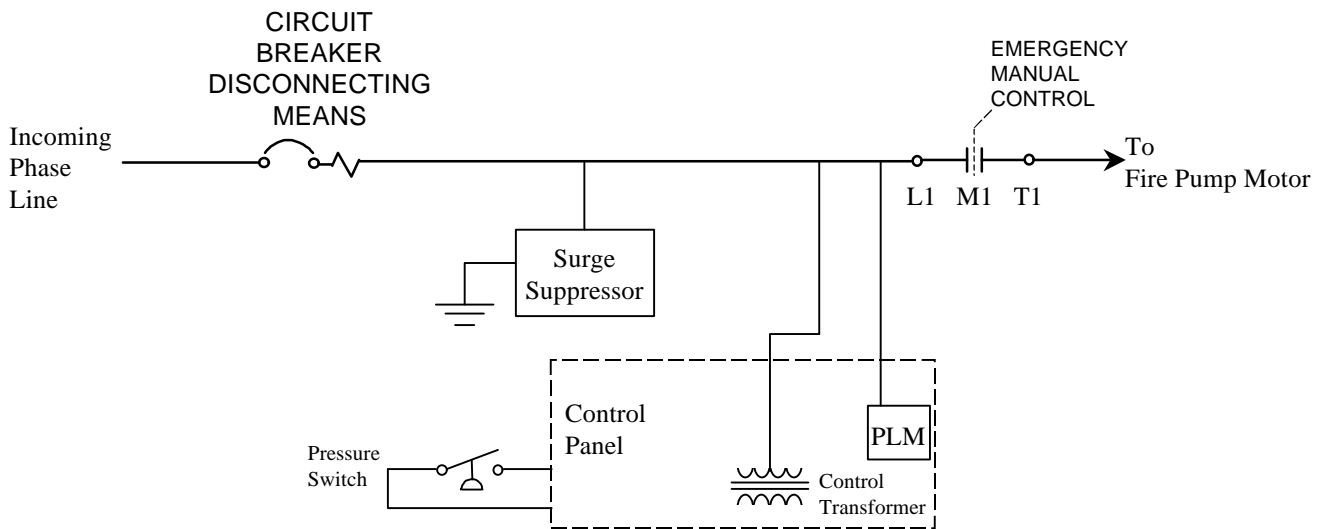

Figure I-1 Block diagram of LX-1500 showing one phase

II Specifications and Certifications

Specifications

Voltage	208, 240, 380, 480C
Phase Loss/Reversal Module	A-B-C phase rotation
200 Series	208–240 VAC, 60 Hz, 3 phase
300 Series	380–415 VAC, 50 Hz, 3 phase
400 Series	440–480 VAC, 60 Hz, 3 phase
Maximum Voltage	10% of highest nominal voltage
Maximum Frequency Shift	0.1 Hz
Phase Loss	18% of low voltage in one phase

Limited Service Fire Pump Controller

Undervoltage Trip	15% below set point
Time Delays	Pick-up, 1.5 s, fixed Drop-out, 1.5 s, fixed
Output Relays	10 A, 120 VAC 5 A, 240 VAC
Indication	green LED, on for A-B-C phase rotation
Surge Suppressor	650 V rating
Temperature	Operating: -4°F to 104°F (-20°C to 40°C) Storage: -4°F to 182°F (-20°C to 85°C)

Certifications

The Hubbell Limited Service Electric Fire Pump Controller is built to NFPA 20 requirements. The Controller is listed by:

Underwriters Laboratory	Factory Mutual
Underwriters Laboratory Canada	New York City
Canadian Standards Association	

III Receiving, Handling, and Storage

1. Immediately upon receipt, carefully unpack and inspect the Controller for damage that may have occurred in shipment. If damage or rough handling is evident, file a damage claim with the transportation carrier.
2. If the Controller must be stored, cover it and place in a clean, dry location. Avoid unheated locations where condensation can result in damage to the insulation or corrosion of metal parts.

IV Installation

1. Consult the motor nameplate to determine voltage, current, and horsepower rating and compare with the Controller nameplate for matching data.
2. Release the door interlock by moving the **CIRCUIT BREAKER DISCONNECTING MEANS** to the **OFF** position.
3. Inspect the control transformer's primary connections for agreement with the line voltage of the incoming power.
4. Exercise all switches and contactors, without power, to see that they operate freely.
5. Choose a location or base for the Controller that is non-combustible and within site of the motor. The base should not be subject to excessive vibration that may cause erratic operation of the PS (pressure switch). The Controller should be leveled so that the PS is level. Sight across the PS cover screws.

Limited Service Fire Pump Controller

Caution: Before drilling and punching holes in the cabinet for wiring connections, cover the components inside the cabinet with a protective covering. Debris may cause shorts or prevent operation of components.

6. Punch holes in the top or the bottom of the cabinet for conduit.
7. Connect the water pressure sensing line to the PS (1/4 NPT internal, 3/4-16 external, brass) fitting on the bottom of the cabinet. For further details, consult the latest edition of NFPA 20.
8. Connect the power supply conductors to the line side of the CIRCUIT BREAKER in the correct A-B-C phase sequence.
9. Connect the motor conductors to the load side of the motor contactor.

Note

Refer to the Controller field connection diagrams. Per the requirements of NFPA 20, conductors are sized for no less than 125% of the motor FLC (full load current) and not more than the lug sizes provided, as shown on the Controller field connection diagrams. Refer to the NFPA 70 (NEC) for cable ratings. Secure conductors inside the cabinet so they do not interfere with or come in contact with the components.

10. Connect the remote alarm contacts. Refer to the supplied Controller field connection diagram for terminal points.

V Sequence of Operation

The PLM (phase loss/reversal monitor) provides contact output for phase loss and undervoltage (PLM-2) in addition to a separate contact output for phase rotation (PLM-1). Both output relays energize if all three phases are present and the phases are in the proper rotation. If a phase loss or undervoltage condition occurs, only the phase loss relay de-energizes. If the phases are reversed relative to the sequence on the PLM, only the phase reversal relay de-energizes. If there is a total loss of the three-phase voltage, both output relays de-energize.

Closing the CIRCUIT BREAKER DISCONNECTING MEANS energizes the PLM and the control transformer. After a 3–5 second delay, contacts PLM-1 open and the PHASE REVERSAL light should go off. If there is a phase reversal, PLM-1 remains closed to turn on the PHASE REVERSAL light and energize the PRR (phase reversal relay) to provide remote indication of phase reversal. The PLM-2 contacts also close, after the 3–5 second delay, to turn on the POWER AVAILABLE light and energize the PFR (phase failure relay) to provide remote indication that power is available.

Automatic Start - When the PS (pressure switch) contacts close due to a decrease in pressure, the CR relay coil energizes. The CR contacts close to energize the TR1 timing relay, factory set at 10 minutes, to begin timing. The TR1 contacts close to latch the CR relay and bypass the PS. The CR contacts also energize contactor coil M1 to start the motor. If the pressure increases, the PS contacts open to de-energize the CR relay and stop the motor, if TR1 has timed out. If TR1 is

Limited Service Fire Pump Controller

still timing, the CR relay remains energized and the motor continues to run for the duration of the timer setting.

Pressing the **STOP** push button stops the motor even if TR1 is timing. If the Controller does not have a TR1 timing relay, the pump motor runs until the **STOP** push button is pressed.

Manual Local Start - Pressing the **START** push button energizes relay LRSR. The LRSR contacts close to latch the LRSR relay and energize the M1 contactor coil to start the motor. The motor runs until the **STOP** button is pressed to de-energize the LRSR coil.

Manual Stop – Connecting the jumper wire between TB2-4 and TB2-5 bypasses the TR1 timing relay contacts. When this jumper is installed, the motor runs until the **STOP** button is pressed.

Remote Start - The remote start circuit requires the closure of remote contacts to start the motor. Closing the remote contacts energizes the LRSR relay. The LRSR contacts close and latch the LRSR relay until the **STOP** button is pressed.

Deluge Valve Start – A normally closed remote switch energizes the optional deluge valve relay (DVR). Opening the remote switch de-energizes the DVR, closing the DVR contacts in parallel with the PS contacts, to energize the CR relay and the TR1 timing relay. When the remote switch closes, the DVR contacts open to de-energize the CR relay and stop the motor, if TR1 has timed out.

Lockout – (This feature is not allowed per NFPA 20 and is permitted only when acceptable to the authority having jurisdiction.) The lockout circuit requires the closure of remote contacts to stop the motor. Closure of the contacts energizes the LK relay. Contacts LK open to de-energize the CR relay and stop the motor. If the remote contacts open while the pressure is low, the motor restarts.

EMERGENCY MANUAL CONTROL - The emergency start handle should only be used if the Controller fails to start automatically or with the **START** push button. The motor runs until the handle is returned to the **OFF** position or the **CIRCUIT BREAKER** is opened. To start the motor when control power is not available, **push the T-handle in and rotate counterclockwise (45°) to lock in the full ON position in a fast and continuous motion.**

<p>Caution: Failure to engage the handle in a fast and continuous motion can result in damage to the contactor and failure to start the motor.</p>

Pump Run Contacts - The pump run contacts transfer any time the M1 contactor is closed by either electrical or mechanical means.

Phase Loss Contacts - The phase loss contacts transfer when line or control power is lost or the line voltage drops more than 15 percent.

Phase Reversal Contacts - The phase reversal contacts transfer when there is a phase reversal, rotation other than A-B-C.

VI Start Up Procedure

Danger: Shocks, burns, or death may result from high voltage.

Caution: Only personnel who are familiar with the power distribution system and this manual should be allowed to perform this procedure.

1. Verify that the motor nameplate horsepower and voltage match the Controller nameplate.
2. Verify that the CIRCUIT BREAKER DISCONNECTING MEANS is open. Check with the electrician to see if the Controller is connected directly to the main transformer. If so, apply the Service Disconnect label above the CIRCUIT BREAKER handle operator.
3. Verify that the PLM is set to the line voltage.
4. Verify that the customer connections to the CIRCUIT BREAKER and contactor are properly tightened.
5. Carefully remove the foam packing from the PS (pressure switch) between the mercury switch and the bourdon tube. Remove the installation instructions above the tube. Replace plastic cover.
6. Adjust the PS set points on the right side of the switch to meet water system requirements. Set the upper pointer to the required STOP (HIGH) pressure setting. Set the lower pointer to the required START (LOW) pressure setting.

The scale on the PS is only for initial positioning of the pointers. During testing of the Controller, verify the PS settings by referring to the system pressure gage. Readjust settings as necessary to obtain desired STOP and START settings. Refer to the instructions packed in the PS and NFPA 20 for more information on adjusting the settings.

7. Verify that the minimum run timer TR1 is set for 10 minutes, per NFPA 20. The timer can be field set as required by local jurisdiction.
8. Close the cabinet door and close the CIRCUIT BREAKER DISCONNECTING MEANS. After a five second delay, verify that the POWER AVAILABLE light is on. If equipped with a Transfer Switch, verify that the green LED on the PRM (phase reversal monitor) is on after a five-second delay. If the LED's are not on, open the CIRCUIT BREAKER and change any two leads (L1, L2, and L3) on the PLM. If equipped with a Transfer Switch, change the same two leads on the PRM.

Caution: Note that the pump should be primed and the water source available before running to avoid damage to the pump. To avoid flooding, ensure the sprinkler system is completely installed and ready to be pressurized.

9. *Bump* the motor by pressing the START button and then press the STOP button, to check for proper rotation. If not correct, open the CIRCUIT BREAKER and change any two leads on the load side of the M1 contactor.
10. Press the START push button. Verify that the motor starts properly and runs at full speed.

Limited Service Fire Pump Controller

11. Press the STOP push button to stop the motor.
12. Start and stop the motor with the EMERGENCY MANUAL CONTROL handle. Push and rotate the T-handle in a **quick motion** to lock the contactor in the ON position to start. Rotate the T-handle clockwise and release to stop the motor.

Caution: Failure to engage the handle in a fast and continuous motion can result in damage to the contactor and failure to start the motor.

If equipped with an LX-250 or LX-350 Automatic Transfer Switch, complete the following additional tests:

1. Verify connection of the engine generator set start wires to TB-1 and TB-2 at the top of the LX-250 Transfer Switch power panel or to TB8-1 and TB8-2 on the left side of the LX-350 Transfer Switch power panel.
2. Close the FIRE PUMP (emergency) ISOLATING SWITCH and open the CIRCUIT BREAKER. The Automatic Transfer Switch should transfer to the alternate source per system requirements. *Bump* the motor to check for proper rotation. If incorrect, move the FIRE PUMP ISOLATING SWITCH to the OFF position and switch the generator set off using the switch located on the generator. Switch any two leads on the line side of the FIRE PUMP ISOLATING SWITCH. Return the generator set control switch to the Auto position and close the FIRE PUMP ISOLATING SWITCH. The generator set may start.
3. Operate the pump on the alternate (emergency) source using the START and STOP push buttons.
4. Close the CIRCUIT BREAKER. The Control Module should now be sensing normal power and timing for retransfer. Press the BYPASS RETRANSFER TO NORMAL push button to return the Transfer Switch to the normal position.

VII Maintenance

Danger: Do not open the Controller cabinet until ALL power is disconnected. Shocks, burns, or death may result from high voltage.

Caution: Only personnel who are familiar with the power distribution system and this manual should be allowed to inspect or perform maintenance on the Controller.

Preventive Maintenance

- A. Protect the equipment against accumulation of dust and metal chips.
- B. Protect the equipment against conditions that result in excessive moisture.
- C. Exercise the equipment every week as part of routine maintenance to verify the integrity of the Controller, Transfer Switch, generator set, power conductors, pump, and motor.
- D. Field lubrication is not necessary or required for the Controller.

Troubleshooting

 **DANGER**

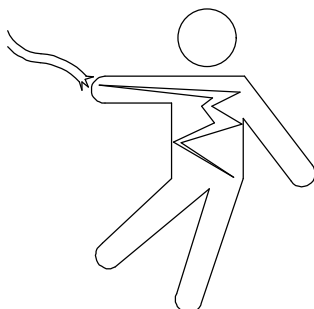

Hazardous voltage will shock, burn, or cause death. Do not touch until ALL power is disconnected.

Warning: Disconnect ALL power supply sources to the Controller before servicing to prevent shock or accident hazard.

Before attempting any troubleshooting on the Controller, verify that the cause of a problem is not due to the motor, pump, or power source. Then visually inspect the Controller for component damage and loose wiring. If the problem cannot readily be resolved, review the Sequence of Operation section for proper operation. Then refer to the supplied wiring diagram and schematic and use a volt/ohm meter to check the wiring to determine which component is faulty.

Coil and Contact Replacement

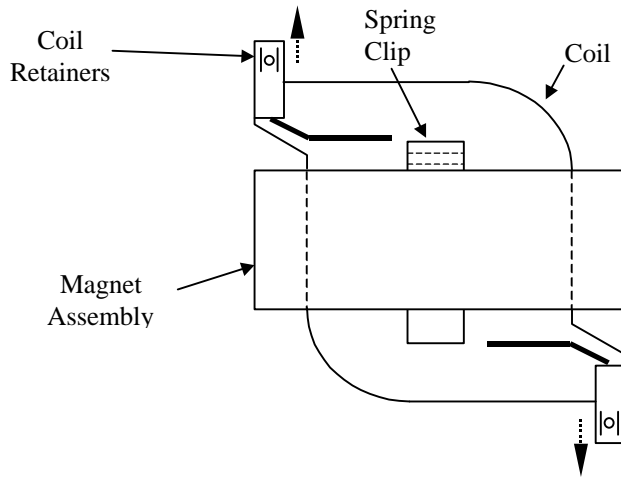

Figure VI-1 Magnet Assembly and Retainers

	Coil Replacement*	Contact Replacement*
1.	Isolate all power sources.	Complete steps 1 through 5 in left column.
2.	While pressing against the coil, pull up slightly on the coil retainers and swing away from coils.	Remove the magnet assembly from the molded cover and movable arm.
3.	Pull the magnet assembly, coil, molded cover, and movable arm from the contactor.	Remove the return spring from the center of movable arm.
4.	Remove the spring clip and remove the armature from movable arm.	Remove the molded cover from movable arm.
5.	Remove the coil from the magnet.	Press and slide the movable contact and spring from movable arm.
6.	Replace the coil and reassemble.	Remove the screws holding stationary contacts in place and remove stationary contacts.
7.		Replace contacts and reassemble.

Notes for re-assembly*:

- a. The molded cover only fits one way.
- b. The magnet and movable arm fit either way but operates more quietly if reassembled the same way before removal.
- c. Do not attempt to remove or replace arc traps in cover.

*Source: General Electric, GEH-5168

Limited Service Fire Pump Controller

VIII Limited Service Fire Pump Controller Parts

Spares	Symbol	Description	Function	Part No.
1 1	CR, LRSR LK, PFR, PRR	High Voltage Relay 2-Pole Relay	Starting Relay Control Relay	31658141 31658123
2	FU1, FU2	Fuse, 1 A, MDL-1	Control Power	57361726
1	TR1	Timing Relay, octal	Min. Run Time	31658111
		Octal socket 2-Pole Relay socket High Voltage Relay socket	TR1 LK, PRR, PFR CR, LRSR	48518012 48518018 48518022
1	PLM	Phase Monitor, 208–240 V Phase Monitor, 440–480 V	Phase Loss/Reversal	57418398 57418399
1	XFMR	Transformer, 208/230/380/460 V	Control Power, 120 V	57511355
1	PS	Pressure Switch, 10-300 PSI	1 NC contact	57501023
	EPR	Pressure Recorder, 300 PSI	Battery driven	57501013
		Operating handle	Circuit Breaker	57504087
		Emergency Manual T-handle Emergency Operator Push Rod Emergency Push Rod Pin	Emergency Operator	91158006 91158005 57401033
	PB1 PB2	Push button NO, green Push button NC, red	Start push button Stop push button	80320105 80320104
2	PL4, 5, 6, 7	Bulb	Indicating lights	80324905
	PL4, 5, 6, 7	Lamp Socket	Indicating lights	402066520
	PL5, 6, 7 PL4	Red lens Clear lens	Phase Reversal Power Available	402067520 402157520
	SS	Surge Suppressor	Surge suppression	402165820

Limited Service Fire Pump Controller

Spares	Symbol	Description	Function	Part No.
	CB (Note 3)	Breaker, 15 A Breaker, 20 A Breaker, 25 A Breaker, 30 A Breaker, 40 A Breaker, 50 A Breaker, 60 A Breaker, 70 A Breaker, 90 A Breaker, 110 A Breaker, 125 A Breaker, 150 A	Circuit Breaker Discounting Means	57504463 57504373 57504371 57504103 57504378 57504389 57504346 57504347 57504348 57504541 57504101 57504344
	M1	Contactor, 200/208 Contactor, 220/240 Contactor, 440/480	Main Contactor	57300333 57300330 57300331
		Contactor Coil, 200/208 Contactor Coil, 220/240 Contactor Coil, 440/480		57300570 57300571 57300573
	M1a1, M1b1	Auxiliary Contact, M1	Pump Run Contact 1 NO and 1 NC Contact	57300391

Notes

1. Specify Controller serial number, model number, horsepower, and voltage when ordering parts.
2. Refer to Bulletin 1000 for information on one-year parts and labor warranty.
3. Consult factory for Spectra Circuit Breakers with high interrupt ratings.