



# User's Manual of the DAG Key Gen. 6

Model: HS1





## Contents

- 1 General operation of the key ..... 3
- 2 Operating frequencies of HF transferral ..... 3
  - 2.1 3-channel ..... 3
  - 2.2 Operation of channel-frequencies and power-modes..... 4
- 3 Block diagram ..... 4
- 4 Technical data ..... 5
  - 4.1 Electrical characteristics ..... 5
  - 4.2 General HF specification..... 5
  - 4.3 Disposal ..... 5
- 5 Declaration of Conformity, product Label ..... 6
  - 5.1 Radio equipment authorization to FCC in USA ..... 6
  - 5.2 Radio equipment authorization to RSS-210 in Canada..... 6
  - 5.3 Location of product label..... 6



## 1 General operation of the key

The DAG Key Gen. 6 consists of a HF transceiver. It is used to transmit the information for locking or unlocking the vehicle by an uni-directional (Remote Keyless Entry→RKE) or bi-directional (Keyless Go/Start operation after a LF Wake Up→KG) HF transmission.

At KG the Vehicle Key reacts on a LF Wake Up-Signal from the vehicle (initiated after push of the Start/Stop-button of the vehicle or a sensor, which recognizes the wish to lock or unlock the vehicle or to open the trunk) from the vehicle and after that a bi-directional HF communication for authorization is initiated. When the authorization is successful the vehicle performs the desired action.

For RKE there are two separate buttons each one for locking and unlocking the vehicle. The keys for all vehicles with a boot lid are additionally equipped with a third button to open or close the trunk. The key is provided with an additional button to (de-)activate the "PANIC" function for the vehicles intended for the US market.



2 Buttons



3 Buttons



2 Buttons + Panic



3 Buttons + Panic

In general the following functions are provided:

- Lock the car (KG and RKE)
- Unlock the car (KG and RKE)
- Open/Close the trunk of the car (KG and RKE, only 3 button variants)
- (De-)Activate Panic Function (only RKE and USA variant)
- Engine Start of the vehicle (KG)

For emergency start, when the battery power is too low, the DAG Key Gen. 6 has a bi-directional very short range (< 10cm) LF-Transponder interface .

## 2 Operating frequencies of HF transferral

### 2.1 3-channel

Up to 3 channels are possible. The following table shows the carrier frequency of the individual channels for each frequency band.

Frequency Variant	Frequencies		
	Channel 1 (CH1)	Channel 2 (CH2)	Channel 3 (CH3)
433.92MHz	433.47MHz	434.37MHz	433.92MHz
315MHz	314.00MHz	314.90MHz	314.45MHz



## 2.2 Operation of channel-frequencies and power-modes

Normally each key operates in 3-channel mode at the respective frequencies listed above. Since some countries allow operation with higher HF-transmitter power, the key fob can be configured between two RF power modes.

When individual frequencies of the 3 HF-channels are not allowed to use this channel(s) will be switched off. This especially information depends on the countries and is available by the country code of the electronic ignition switch. The key changes its operation at the first time it is be authentically used. The change of used channel frequencies and power mode is durable locked and can not be changed after this.

## 3 Block diagram

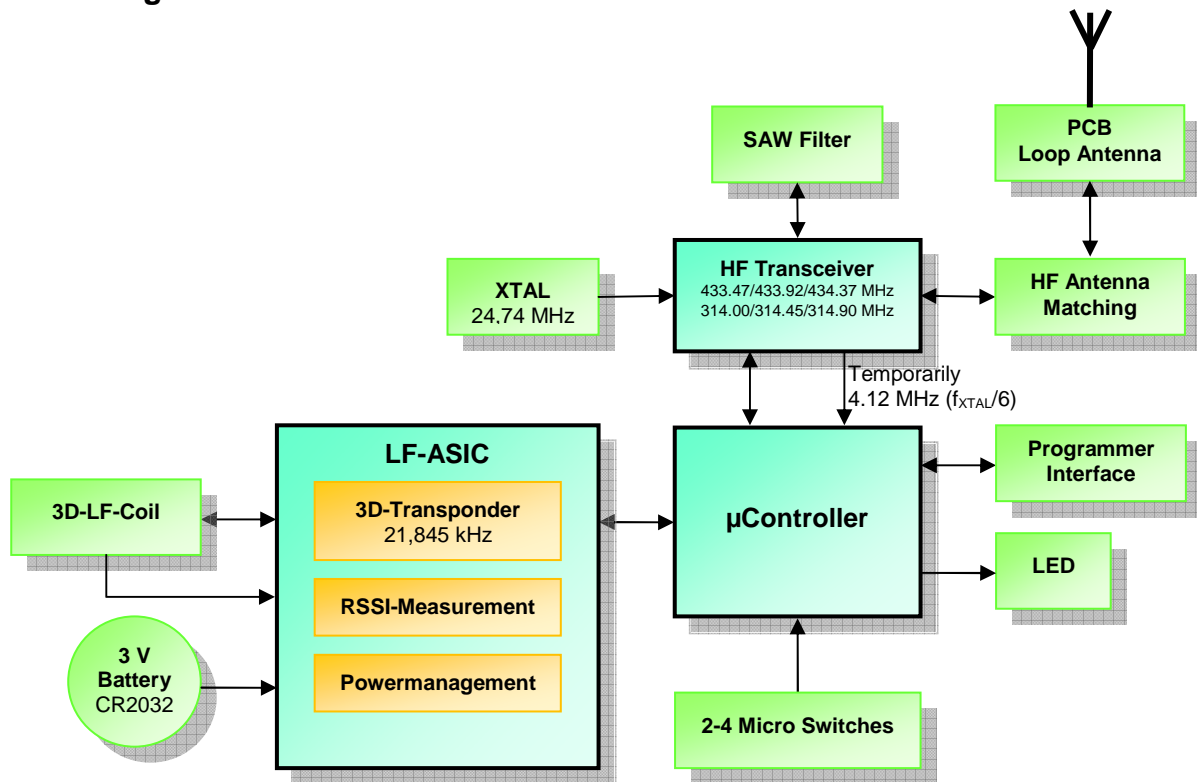



## 4 Technical data

### 4.1 Electrical characteristics

Power supply:	Battery (CR2032, coin cell)		
Type of Battery:	Lithium		
Voltage range:	2,1V ... 3,2V		
Temperature range:	RKE/KG:	-20°C ... +65°C	
	Emergency start:	-40°C ... +85°C	

### 4.2 General HF specification

3-channel operation:

$$f_{op1} = 433.47 \text{ MHz} / 433.92 \text{ MHz} / 434.37 \text{ MHz}$$
$$f_{op2} = 314.00 \text{ MHz} / 314.45 \text{ MHz} / 314.90 \text{ MHz}$$

Transmission power EIRP:

433.92 MHz variant:	< -14.4 dBm
315 MHz variant:	< -19.6 dBm

Type of modulation: FSK, deviation  $\pm 10$  kHz

Type of HF antenna: PCB Loop antenna

### 4.3 Disposal

An old battery must be lodged at a collection point or the service.



## 5 Declaration of Conformity, product Label

### 5.1 Radio equipment authorization to FCC in USA

**FCC ID: YGOHS1**

The transmitter will be supplied as an original equipment device to the car manufacturer.

According to 47 CFR 15.19 (labeling requirements) the car manufacturer will print the following text in the appropriate User's Manual of the car:

This device complies with Part 15 of the FCC Rules. Operation is subject to the following two conditions:

- (1) This device may not cause harmful interference, and
- (2) this device must accept any interference received, including interference that may cause undesired operation.

Usually this is followed by the following FCC caution:

Any changes or modification not expressly approved by the party responsible for compliance could void the user's authority to operate this equipment.

### 5.2 Radio equipment authorization to RSS-210 in Canada

**IC: 4008C-HS1**

The transmitter will be supplied as an original equipment device to the car manufacturer.

According to RSS-210 (labeling requirements) the car manufacturer will print the following text in the appropriate User's Manual of the car:

This device complies with Industry Canada licence-exempt RSS standard(s). Operation is subject to the following two conditions:

- (1) This device may not cause harmful interference, and
- (2) this device must accept any interference received, including interference that may cause undesired operation.

Le présent appareil est conforme aux CNR d'Industrie Canada applicables aux appareils radio exempts de licence. L'exploitation est autorisée aux deux conditions suivantes:

- (1) l'appareil ne doit pas produire de brouillage, et
- (2) l'utilisateur de l'appareil doit accepter tout brouillage radioélectrique subi, même si le brouillage est susceptible d'en compromettre le fonctionnement.

Usually this is followed by the following RSS caution:

Any changes or modification not expressly approved by the party responsible for compliance could void the user's authority to operate this equipment.

### 5.3 Location of product label

The product label with FCC ID and IC certification number can be found under the battery cover.