



**Technical Description
and
User's Manual
of the
Volvo Scaleable Platform Architecture
(SPA) Standard Key**

Model: HUF8423, HUF8424, HUF8425



Volvo SPA Standard Key
HUF8423, HUF8424, HUF8425



Contents

1 General operation of the key	3
2 Operating frequencies of HF transmission	3
2.1 2-channel	3
3 Block diagram	4
4 Technical data	4
4.1 Electrical characteristics Volvo SPA Standard Key	4
4.2 General HF specification.....	4
4.3 Disposal	4
5 Declaration of Conformity, product Label.....	5
5.1 Radio equipment authorization to FCC in USA	5
5.2 Radio equipment authorization to RSS-210 in Canada.....	5
5.3 Location of product label.....	5



1 General operation of the key

The Volvo SPA Key has implemented a HF transmitter. It can transmit the information when pressing a button for locking or unlocking the vehicle by an uni-directional command via Remote Keyless Entry (RKE) or there can be a bi-directional communication when Keyless Entry & Start functionality is requested via a LF Wake Up command issued by the vehicles antennas and the key responds in HF.

With Keyless Entry or Start the Volvo SPA Standard key reacts on a LF Wake Up-Signal from the vehicle (initiated after activating of the sensor of the vehicle, i.e. at sensor at the door handle or the Push Start Button, which recognizes the wish to lock/ unlock the vehicle or to open the trunk or to start the vehicle) from the vehicle and after that the key responds in HF on the RKE frequency for authorization purposes. When the authorization is successful the vehicle performs the desired action.

On the Volvo Standard Key there are four separate buttons, from which three of them are dedicated to locking&unlocking the vehicle and open/close the trunk. The fourth button on the Volvo Standard key has the functionality of activating or deactivating the "PANIC" feature.

In general the following functions are provided:

- Lock the car (Keyless Entry and RKE)
- Unlock the car (Keyless Entry and RKE)
- Open/Close the trunk of the car (Keyless Entry and RKE)
- Activate or Deactivate "Panic" feature (only RKE)
- Engine Start of the vehicle (Keyless Start)

When the battery power is too low, the key can start the vehicle with the emergency back up function via the LF-Transponder interface @134,2 kHz (by placing it near the transponder coil located near the steering column inside the vehicle) which operates at a very short range (< 10cm).

2 Operating frequencies of HF transmission

2.1 2-channel

Two channels are implemented on the 434MHz variant (excl. South Korean variant) and on the 315MHz variant. The following table shows the carrier frequency of the individual channels for each frequency band.

Frequency Variant	Frequencies	
	Channel 1 (CH1)	Channel 2 (CH2)
315MHz	314.37MHz	314.97MHz
434MHz (excl. S. Korea)	433.66MHz	434.18MHz
434MHz S. Korea	433.92MHz	---



3 Block diagram

3.1 Volvo SPA Standard Key:

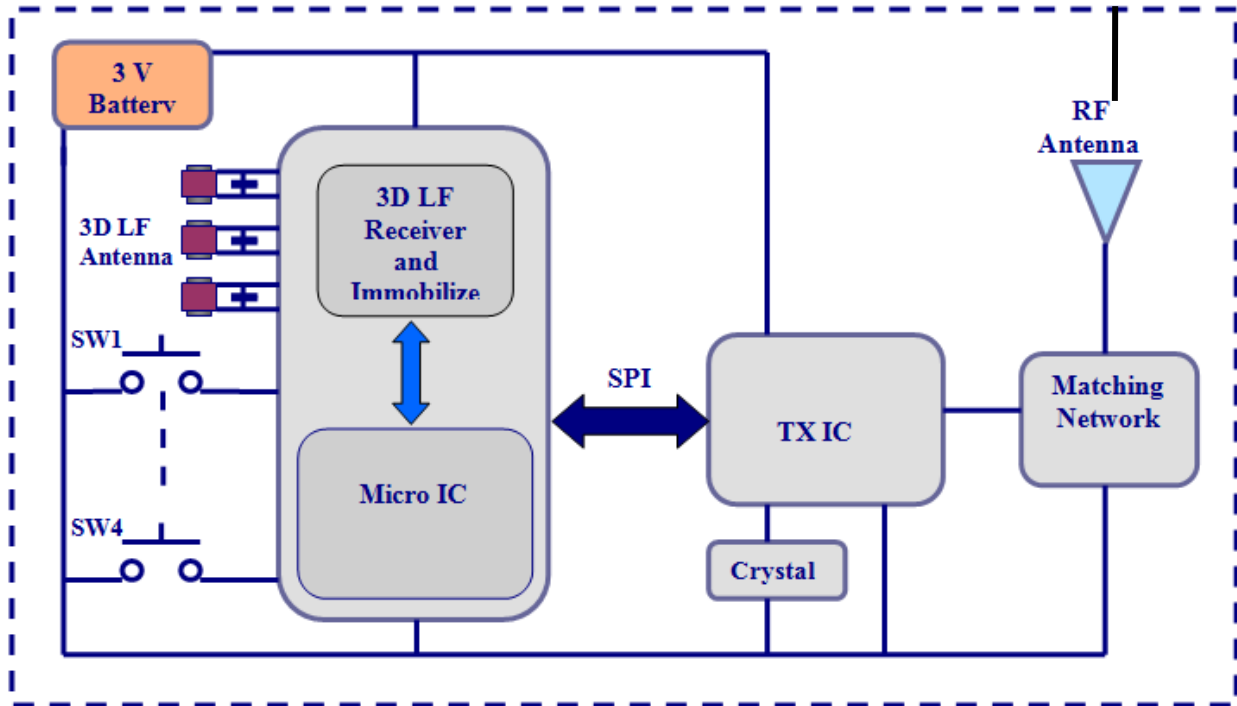

4 Technical data

4.1 Electrical characteristics Volvo SPA Standard Key

Power supply:	Battery (CR2032, coin cell)		
Type of Battery:	Lithium		
Voltage range:	2,3V ... 3,3V		
Temperature range:	RKE/ Keyless Entry/Start:	-20°C ... +65°C	
	Emergency start:	-40°C ... +85°C	

4.2 General HF specification

2-channel operation:

$$f_{op1} = 314.37 \text{ MHz} / 314.97 \text{ MHz}$$

$$f_{op2} = 433.66 \text{ MHz} / 434.18 \text{ MHz}$$

1-channel operation (narrow band)

$$f_{op} (\text{S. Korea}) = 433.92 \text{ MHz}$$

Type of modulation: FSK, deviation $\pm 15.625 \text{ kHz}$

Type of HF antenna: PCB Loop antenna

4.3 Disposal

An old battery must be lodged at a collection point or the service.



5 Declaration of Conformity, product Label

5.1 Radio equipment authorization to FCC in USA

Volvo Standard Key FCC ID: YGOHUF8423

The transmitter will be supplied as an original equipment device to the car manufacturer.

According to 47 CFR 15.19 (labeling requirements) the car manufacturer will print the following text in the appropriate User's Manual of the car:

This device complies with Part 15 of the FCC Rules. Operation is subject to the following two conditions:

- (1) This device may not cause harmful interference, and
- (2) this device must accept any interference received, including interference that may cause undesired operation.

Usually this is followed by the following FCC caution:

Any changes or modification not expressly approved by the party responsible for compliance could void the user's authority to operate this equipment.

5.2 Radio equipment authorization to RSS-210 in Canada

Volvo Standard Key IC: 4008C-HUF8423

The transmitter will be supplied as an original equipment device to the car manufacturer.

According to RSS-210 (labeling requirements) the car manufacturer will print the following text in the appropriate User's Manual of the car:

This device complies with Industry Canada licence-exempt RSS standard(s). Operation is subject to the following two conditions:

- (1) This device may not cause harmful interference, and
- (2) this device must accept any interference received, including interference that may cause undesired operation.

Le présent appareil est conforme aux CNR d'Industrie Canada applicables aux appareils radio exempts de licence. L'exploitation est autorisée aux deux conditions suivantes:

- (1) l'appareil ne doit pas produire de brouillage, et
- (2) l'utilisateur de l'appareil doit accepter tout brouillage radioélectrique subi, même si le brouillage est susceptible d'en compromettre le fonctionnement.

Usually this is followed by the following RSS caution:

Any changes or modification not expressly approved by the party responsible for compliance could void the user's authority to operate this equipment.

5.3 Location of product label

On the Volvo SPA Standard key the product label with FCC ID and IC certification number can be found inside the recess for the mechanical keyblade when removing the cover.