

## Technical Description

### BMW motorcycle Keyless Ride System

#### (BMW motorcycle Keyless Ride ECU & BMW Keyless Ride ID Device)



&



Project designation: Keyless Ride BMW Motorrad

Project numbers: 0905.001 to 0905.004

HUF-authors: L.Patzelt /PDE-H, B.Müller /PDS-CA, D.Steegmann /PDS-PE, u. a.

Date: 04.Nov. 2013

Revision: 02

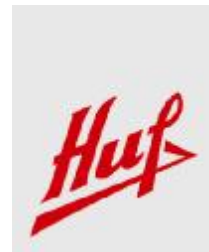

## Contents

<b>1 Abbreviations .....</b>	<b>4</b>
<b>2 General System Description .....</b>	<b>4</b>
<b>3 KR- System components and interaction .....</b>	<b>5</b>
<b>3.1 Main system components: .....</b>	<b>5</b>
<b>3.2 System Functionalities .....</b>	<b>6</b>
3.2.1 Keyless Ride in far field communication.....	6
3.2.2 Immobilizer deactivation option in near field communication .....	6
<b>4 Technical description and user's manual of the BMW Keyless Ride ECU .....</b>	<b>7</b>
<b>5 Additional Fuel Tank Cap opening sequence .....</b>	<b>8</b>
<b>6 Technical specifications ECU- RF-Receiver to ID device .....</b>	<b>8</b>
<b>6.1 ECU- RF-Receiver global parameter: .....</b>	<b>8</b>
<b>6.2 Crystal Oscillator clock for <math>\mu</math>C MC9S12XS256CAE .....</b>	<b>9</b>
<b>6.3 Crystal Oscillator clock at RF- Receiver TDA5235 .....</b>	<b>9</b>
<b>6.4 Ceramic-Resonator clock at LF-Transponder Base Station TMS3705A.....</b>	<b>10</b>
6.4.1 Communication Modes.....	10
<b>7 ECU CAN Communication .....</b>	<b>11</b>
<b>8 Location of product label.....</b>	<b>11</b>
<b>9 Declaration of Conformity, product label of the ECU .....</b>	<b>11</b>
<b>9.1 Radio equipment authorization to FCC in USA .....</b>	<b>11</b>

Project designation: Keyless Ride BMW Motorrad

Project numbers: 0905.001 to 0905.004

HUF-authors: L.Patzelt /PDE-H, B.Müller /PDS-CA, D.Steegmann /PDS-PE, u. a.

Date: 04.Nov. 2013

Revision: 02



9.2 Radio equipment authorization to RSS-210 in Canada .....	12
<b>10 Technical description and user's manual BMW KR ID device .....</b>	<b>15</b>
10.1 Usage of the BMW KR ID device .....	16
10.2 General description of the RF transmitter BMW KR ID device .....	16
10.3 Power supply .....	16
10.4 Buttons.....	17
10.5 Protocol overview .....	17
10.6 Block diagram.....	18
10.7 ID device- Models/ Variants .....	19
10.8 Technical Data .....	19
10.9 Disposal .....	20
10.10 Location of product label.....	20
10.11 Declaration of Conformity, product label of the ID device.....	20
10.11.1 Radio equipment authorization to FCC in USA .....	20
10.11.2 Radio equipment authorization to RSS-210 in Canada .....	21

Project designation: Keyless Ride BMW Motorrad

Project numbers: 0905.001 to 0905.004

HUF-authors: L.Patzelt /PDE-H, B.Müller /PDS-CA, D.Steegmann /PDS-PE, u. a.

Date: 04.Nov. 2013

Revision: 02

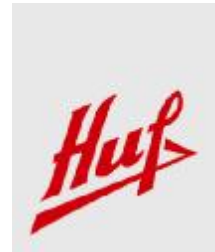

## 1 Abbreviations

KR	Keyless Ride
LF	Low Frequency
HF	High Frequency
ECU	Electronic Control Unit
CAN	Controller Area Network
ID-device	Identifier remote key
PCB	Printed Circuit Board
PLL	Phase Lock Loop
DWA /ZV	anti-theft alarm-, central latching system
RoW	Rest of World

## 2 General System Description

The motorbike's KR-system is part of the BMW motorcycle version K48. It allows the user to mobilize or immobilize the motorcycle by use of a valid remote key. It's available for three different RF- carrier frequencies: 315,0 MHz, 433,92 MHz and 434,42 MHz. However, this descriptive text is mainly oriented to the required facts concerning the wireless LF- and RF- interface homologation. The KR-system is specified for a temp.- range of  $T_{amb} = 20$  to  $85^{\circ}\text{C}$ .

The KR-system consists the two main components:

- BMW motorcycle Keyless Ride ECU
- BMW Keyless Ride ID Device

The motorcycle mobilization/ immobilization followed by ignition ON/OFF can be performed by pushing the button (S0) of the KR-ECU placed in the cockpit at the steering column. The KR-ECU is supplied in the voltage range 9,0 to 16,0 V derived from the motorbikes 12V-battery.

The functional condition the motorcycle's velocity must be less than 2 km/h. This information is delivered by CAN messages monitored and controlled by the ECU controller.

Project designation: Keyless Ride BMW Motorrad

Project numbers: 0905.001 to 0905.004

HUF-authors: L.Patzelt /PDE-H, B.Müller /PDS-CA, D.Steegmann /PDS-PE, u. a.

Date: 04.Nov. 2013

Revision: 02

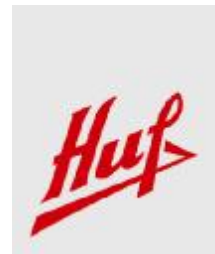

## 3 KR- System components and interaction

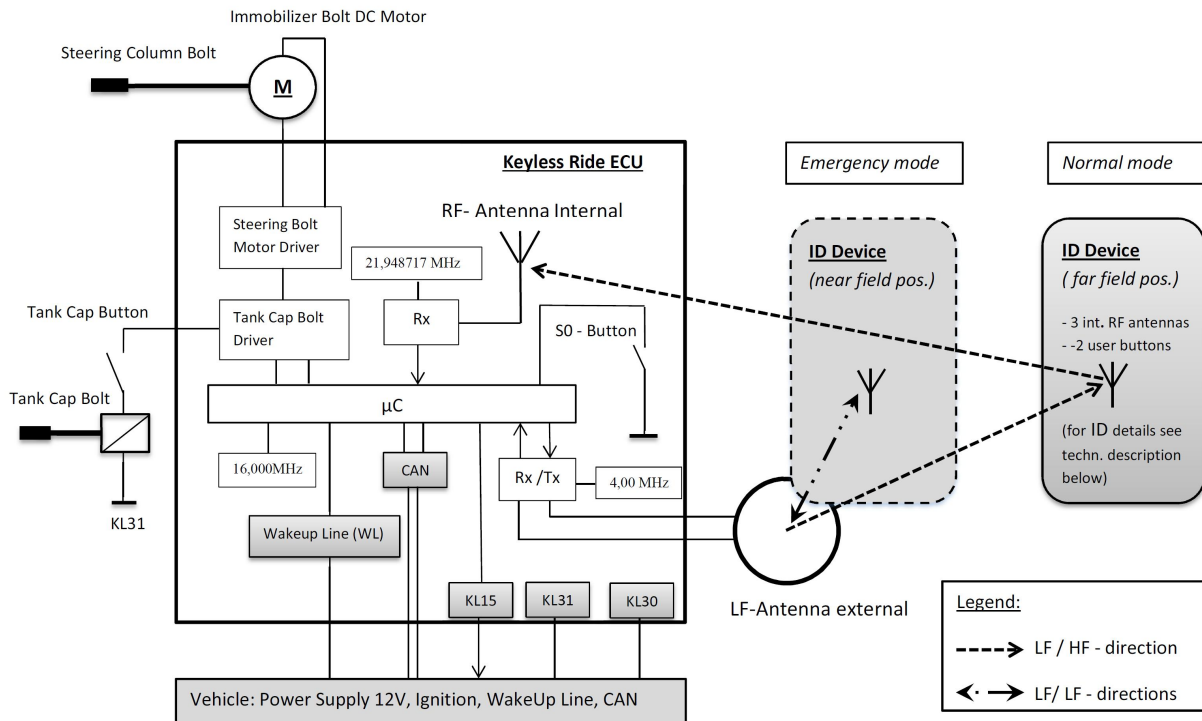

The interactions between the KR ECU and the ID device (remote key) is performed in the two different ways:

1. *Normal mode*: The unidirectional RF- communication uses the multi-band RF-Receiver IC **TDA 5235** / Infineon. It is the user standard mode.
2. *Emergency mode*: The bidirectional LF- communication based on Transponder LF-Base station IC **TMS3705A** / ti. Mode is used in cases when the ID device battery is discharged.

### 3.1 Main system components:

- S0 button controls different KR-ECU functions; see chapter 4

Project designation: Keyless Ride BMW Motorrad

Project numbers: 0905.001 to 0905.004

HUF-authors: L.Patzelt /PDE-H, B.Müller /PDS-CA, D.Steegmann /PDS-PE, u. a.

Date: 04.Nov. 2013

Revision: 02

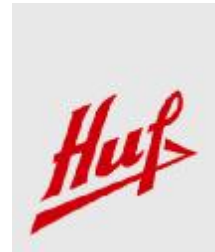

## **Technical System Description Keyless Ride BMW Motorrad**

- Keyless Ride ECU operates the ECU function sequences based received messages and signals
- Rx interface and RF-antenna for unidirectional HF- communication
- Rx /Tx interface and LF-antenna for bidirectional LF- communication
- External Tank Cap Button to wake up the ECU and steer the tank cap bolt coil
- WL / Wake Up Line used to wake up the ECU
- KL15 output steered by the Keyless Ride ECU
- CAN for communication via bus used as well as a continuous vehicle speed monitor
- Keyless Ride ID device. It defines and match a legal user and activates / deactivates central locking and anti-theft alarm.
- ECU internal RF antenna
- Steering column bolt
- CAN interface

## **3.2 System Functionalities**

### **3.2.1 Keyless Ride in far field communication**

A pressed button S0 placed on the KR-ECU causes switching on the external vehicle LF- antenna. A message is sent out via a LF-field up to an operating distance of 1m. When an ID device is matched in this range, it will be woken up. The ID device itself answers via the HF-field by a message back to the KLR-ECU and the steering column is locked or unlocked as well as the ignition is switched ON/OFF. The HF-field operates in a range up to 10 m.

### **3.2.2 Immobilizer deactivation option in near field communication**

In case that the wireless key's power supply is too low for HF-communication, it is possible to place the ID device directly on the LF- antenna ( distance ca. 3cm). After the button (S0) is pressed the ID device is supplied by the induction field of the LF- antenna directly, waked up and now able to answer backwards also via the adjacent LF- antenna.

Project designation: Keyless Ride BMW Motorrad

Project numbers: 0905.001 to 0905.004

HUF-authors: L.Patzelt /PDE-H, B.Müller /PDS-CA, D.Steegmann /PDS-PE, u. a.

Date: 04.Nov. 2013

Revision: 02

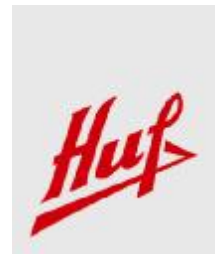

## 4 Technical description and user's manual of the BMW Keyless Ride ECU

Basic Condition	Control Element Activation	KR-ECU Function
<b>i) Execution ECU condition changes to mobilization with ignition "ON"</b>		
+ KL15 "OFF", KR ECU in steering lock position (bolt out)  + User authentication is matched ->"OK"  + <u>Test Set Up</u> : No external CAN interface is implemented	a) Pressing the push button (S0) twice in two short steps ( $t < 1s$ ).	<ul style="list-style-type: none"> <li>• <u>Step 1</u>: Unlocking unlock the steering lock, bolt moves in unlock position (bolt in).</li> <li>• <u>Step 2</u>: KL15 switches "ON"</li> </ul>
	b) <u>Optional</u> : Also by a permanent pressed push button (S0) for $t > 2s$ both of these functions are performed in sequence automatically.	<ul style="list-style-type: none"> <li>• Locking bolt moves in unlock position (bolt in). <i>(automatically followed by)</i></li> <li>• KL15 switches "ON"</li> </ul>
<b>ii) Execution ECU condition changes to immobilization with KL15 "OFF"</b>		
+ KL15 "ON", KLR ECU in steering unlock position (bolt in)  + User authentication is matched ->"OK"  + <u>Test Set Up</u> : No external CAN interface is implemented.	c) <i>Press the push button (S0) once <math>t &gt; 2s</math>.</i>	<ul style="list-style-type: none"> <li>• KL15 switches "OFF"</li> </ul>
	d) <i>Waiting for 30s in minimum is necessary because in the test set up no CAN bus exists.</i>	<ul style="list-style-type: none"> <li>• No condition change</li> </ul>

Project designation: Keyless Ride BMW Motorrad

Project numbers: 0905.001 to 0905.004

HUF-authors: L.Patzelt /PDE-H, B.Müller /PDS-CA, D.Steegmann /PDS-PE, u. a.

Date: 04.Nov. 2013

Revision: 02

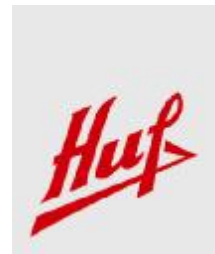

**Technical System Description Keyless Ride BMW Motorrad**

	<p>e) Press the push button (S0) for <math>t &gt; 2s</math> again.</p>	<ul style="list-style-type: none"> <li>• Locking bolt moves in lock position (bolt out)</li> </ul>
--	--	--

## 5 Additional Fuel Tank Cap opening sequence

Additional there is a feature to open the fuel tank latch by steering an electromagnetic bolt of the tank cap. The tank opening cycle starts by pulling the flap button on top of the tank cap manually to wake up the ECU controller followed by unlatch the fuel tank cap bolt steered by the KR-ECU. Opening the tank cap not able at KL15 is ON.

## 6 Technical specifications ECU- RF-Receiver to ID device

The ECU RF-Receiver based on reception of the delivered ID device data stream by three models with different RF- frequencies like follows:

### 6.1 ECU- RF-Receiver global parameter:

Consecutive-No..	Country	Carrier RF-Frequency	Huf Model	Huf PCB- No.
1	Japan	315 MHz	HUF8475	36.484.750
2	South Korea	433,92 MHz	HUF8485	36.484.850
3	Rest of world	434,42 MHz	HUF8465	36.484.650

Project designation: Keyless Ride BMW Motorrad

Project numbers: 0905.001 to 0905.004

HUF-authors: L.Patzelt /PDE-H, B.Müller /PDS-CA, D.Steegmann /PDS-PE, u. a.

Date: 04.Nov. 2013

Revision: 02



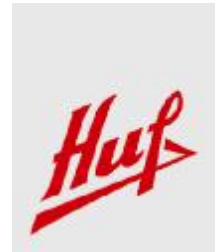

## Technical System Description Keyless Ride BMW Motorrad

### 6.2 Crystal Oscillator clock for $\mu\text{C}$ MC9S12XS256CAE

Crystal Oscillator: NDK: NX3235SA- 16 MHz

Crystal nominal frequency:	16,000 MHz
Initial frequency tolerance ( $T_{amb} = 25 \pm 3^\circ\text{C}$ )	$\pm 15$ ppm
Frequency tolerance vs. temp. ( $T_{amb} = -20\dots85^\circ\text{C}$ )	$\pm 50$ ppm
Aging ( estimated )	$< \pm 10$ ppm / 10 years
-----	
Crystal Internal load capacitance	2 x 8 pF
Crystal External load capacitance	2 x 10 pF

### 6.3 Crystal Oscillator clock at RF- Receiver TDA5235

Crystal Oscillator: NDK: NX3235SA- 21.948717 MHz

Type of Modulation: FSK ( Frequency Shift Keyed ) 434.42MHz and 315MHz

Type of RF antenna: Dipol antenna

Crystal nominal frequency:	21,948717MHz
Initial frequency tolerance ( $T_{amb} = 25 \pm 3^\circ\text{C}$ )	$\pm 15$ ppm
Frequency tolerance vs. temp. ( $T_{amb} = -20\dots85^\circ\text{C}$ )	$\pm 50$ ppm
Aging ( estimated )	$< \pm 10$ ppm / 10 years
-----	
Crystal Internal load capacitance	2 x 8 pF
Crystal External load capacitance	2 x 9 pF

Project designation: Keyless Ride BMW Motorrad

Project numbers: 0905.001 to 0905.004

HUF-authors: L.Patzelt /PDE-H, B.Müller /PDS-CA, D.Steegmann /PDS-PE, u. a.

Date: 04.Nov. 2013

Revision: 02

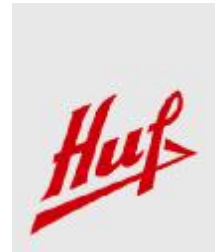

## 6.4 Ceramic-Resonator clock at LF-Transponder Base Station TMS3705A

Used is the Murata Ceramic- Resonator CERALOCK® : CSTCR4M00G55B-R0

Resonator nominal frequency:	4,00 MHz
Initial frequency tolerance ( $T_{amb} = 25 \pm 3^{\circ}C$ )	$\pm 0.5\%$ ; 6.Letter in Part Numbering “=5”
Frequency tolerance vs. temp. ( $T_{amb} = -40 \dots 85^{\circ}C$ )	$\pm 0,06\%$ ; see Test result in App. A.
Aging ( estimated )	$< \pm 0,10\%$ / 10 years
-----	
Resonator internal Load Capacitors	2 x 39 pF(typ.) ; Test result see App. B
-----	
used PLL clock frequency:	16 MHz (internal)

### 6.4.1 Communication Modes

a) Normal Mode “Passive Entry” (ECU LF sends to ID device ; distance range 0 to 1,5m) :

ECU LF generated frequency by IC TMS3705A. The LF (134.45 kHz) is sent from the KR ECU to the ID device. The ID device answers to KR ECU via HF (434,42MHz).

LF baud rate:	1,3kbps
Type of modulation:	FSK
FSK deviation:	$\pm 20$ kHz
Transponder nominal supply voltage:	5,0V $\pm$ 5%

b) Emergency Mode (ECU sends via LF to ID device - ID device sends via LF to ECU ( range 0 to 8 cm) :

LF 134.45 kHz to ID device, but FSK- response at 123,2 and 134.45 kHz via LF Antenna back to ECU.

LF receiver bandwidth:	10kHz
------------------------	-------

Project designation: Keyless Ride BMW Motorrad

Project numbers: 0905.001 to 0905.004

HUF-authors: L.Patzelt /PDE-H, B.Müller /PDS-CA, D.Steegmann /PDS-PE, u. a.

Date: 04.Nov. 2013

Revision: 02



## 7 ECU CAN Communication

The used ECU CAN bus is a High-Speed Power-Train-CAN. It includes a own wake up wire therefore a network management isn't required.

CAN baud rate: 500 kBaud

Diagnostic- protocol: UDS, conform ISO 14229.

## 8 Location of product label

The KR ECU product label position with FCC ID and IC certification number can be found on the housing cover.

## 9 Declaration of Conformity, product label of the ECU

### 9.1 Radio equipment authorization to FCC in USA

**FCC ID: YGOHUF8465**

The transmitter will be supplied as an original equipment device to the vehicle manufacturer.

According to 47 CFR 15.19 (labeling requirements) the vehicle manufacturer will print the following text in the appropriate user's manual of the vehicle:

This device complies with Part 15 of the FCC Rules. Operation is subject to the following two conditions:

- (1) This device may not cause harmful interference, and
- (2) this device must accept any interference received, including interference that may cause undesired operation.

Usually this is followed by the following FCC caution:

Any changes or modification not expressly approved by the party responsible for compliance could void the user's authority to operate this equipment.

Project designation: Keyless Ride BMW Motorrad

Project numbers: 0905.001 to 0905.004

HUF-authors: L.Patzelt /PDE-H, B.Müller /PDS-CA, D.Steegmann /PDS-PE, u. a.

Date: 04.Nov. 2013

Revision: 02

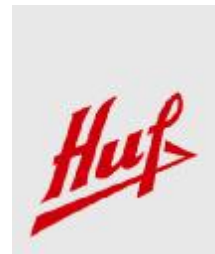

## 9.2 Radio equipment authorization to RSS-210 in Canada

**IC: 4008C-HUF8465**

The transmitter will be supplied as an original equipment device to the vehicle manufacturer.

According to RSS-210 (labeling requirements) the vehicle manufacturer will print the following text in the appropriate user's manual of the vehicle:

Operation is subject to the following two conditions:

- (1) This device may not cause harmful interference, and
- (2) this device must accept any interference received, including interference that may cause undesired operation.

Usually this is followed by the following RSS caution:

Any changes or modification not expressly approved by the party responsible for compliance could void the user's authority to operate this equipment.

- Le présent appareil est conforme aux CNR d'Industrie Canada applicables aux appareils radio exempts de licence.

L'exploitation est autorisée aux deux conditions suivantes:

(1) l'appareil ne doit pas produire de brouillage, et, and (2) l'utilisateur de l'appareil doit accepter

tout brouillage radioélectrique subi, même si le brouillage est susceptible d'en compromettre le fonctionnement. □ □

Project designation: Keyless Ride BMW Motorrad

Project numbers: 0905.001 to 0905.004

HUF-authors: L.Patzelt /PDE-H, B.Müller /PDS-CA, D.Steegmann /PDS-PE, u. a.

Date: 04.Nov. 2013

Revision: 02

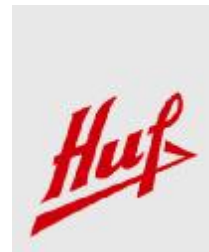

**Appendix A:**

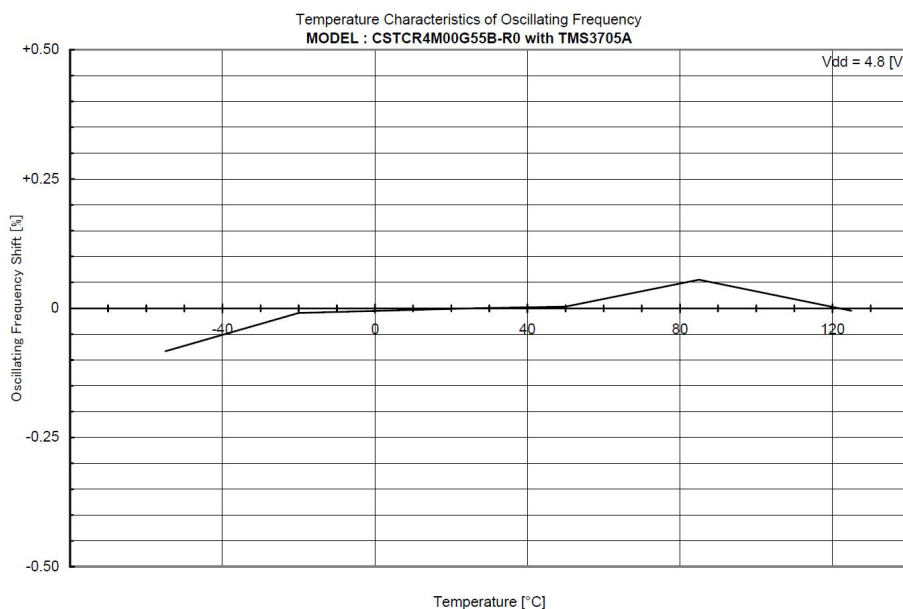

Source of App A: TOYAMA MURATA MANUFACTURING CO.,LTD Jan 6 2004

Project designation: Keyless Ride BMW Motorrad

Project numbers: 0905.001 to 0905.004

HUF-authors: L.Patzelt /PDE-H, B.Müller /PDS-CA, D.Steegmann /PDS-PE, u. a.

Date: 04.Nov. 2013

Revision: 02

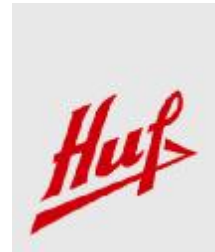

## Appendix B:

Test Circuit

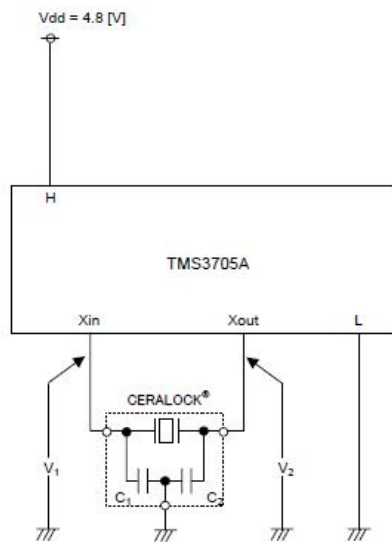

Xin : 11  
Xout: 10  
H : 8,9  
L : 6,12,13,18

Recommended Value

CERALOCK® : CSTCR4M00G55B-R0  
Vdd = 4.5 to 5.1 [V]  
C1 = 39 [pF] (Typ.)  
C2 = 39 [pF] (Typ.)  
Ta = -40 to 85 [°C]

Murata Manufacturing Co., Ltd.

Source of App. B: TOYAMA MURATA INTERNET DATASHEED 2013

Project designation: Keyless Ride BMW Motorrad

Project numbers: 0905.001 to 0905.004

HUF-authors: L.Patzelt /PDE-H, B.Müller /PDS-CA, D.Steegmann /PDS-PE, u. a.

Date: 04.Nov. 2013

Revision: 02

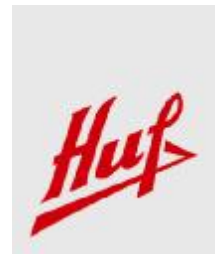

## 10 Technical description and user's manual BMW KR ID device



**Picture: BMW Keyless Ride Key (ID device)**

Project designation: Keyless Ride BMW Motorrad

Project numbers: 0905.001 to 0905.004

HUF-authors: L.Patzelt /PDE-H, B.Müller /PDS-CA, D.Steegmann /PDS-PE, u. a.

Date: 04.Nov. 2013

Revision: 02

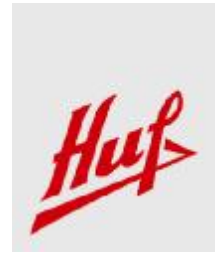

## 10.1 Usage of the BMW KR ID device

The BMW KR ID device will be used in several vehicle lines of BMW motorcycles.

## 10.2 General description of the RF transmitter BMW KR ID device

The RF remote control consists of a RF transmitter.

The BMW KR ID device is used for transmitting the information for locking/unlocking the vehicle's central locking system and arm/disarm the anti-theft alarm system, respectively, via RF transmission for normal remote keyless entry function by pushing a button.

The typical telegram length is approx. 52 ms.

It is repeated every 100 ms, until the button is released or the timeout is reached.

Additionally, the ID device can be woken up via specific LF wake up telegrams from the vehicle and transmit the corresponding RF information for passive start back to the vehicle.

The typical telegram length is approx. 18 ms

In general the following functions are provided:

- send command for locking the vehicle's central locking system
- send command for unlocking the vehicle's central locking system
- send command for arming the anti-theft alarm system
- send command for disarming the anti-theft alarm system
- send command for passive start of the engine (via LF wake up)

For emergency start, in case the battery power of the ID device is too low, the BMW KR ID device has a bi-directional LF transponder interface.

## 10.3 Power supply

The BMW KR ID device is provided with one lithium battery ("coin cell", CR2032), which has a nominal voltage of +3 V.

Project designation: Keyless Ride BMW Motorrad

Project numbers: 0905.001 to 0905.004

HUF-authors: L.Patzelt /PDE-H, B.Müller /PDS-CA, D.Steegmann /PDS-PE, u. a.

Date: 04.Nov. 2013

Revision: 02



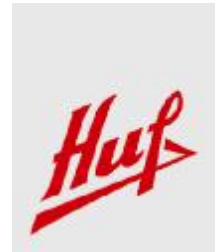

## 10.4 Buttons

There are two buttons which enable locking/unlocking of the vehicle's central locking system and arming/disarming of the anti-theft alarm system.

During activation, the button is forced to ground potential.



<sup>1</sup>CL: central locking  
<sup>2</sup>ATAS: anti-theft alarm system

## 10.5 Protocol overview

After a button push, the BMW KR ID device transmits a RF code telegram for ca. 52 ms.

The telegram is repeated every 100 ms until the button is released or the timeout is reached.

After specific LF wake up telegram, the corresponding RF telegram length is ca. 18 ms.

Project designation: Keyless Ride BMW Motorrad

Project numbers: 0905.001 to 0905.004

HUF-authors: L.Patzelt /PDE-H, B.Müller /PDS-CA, D.Steegmann /PDS-PE, u. a.

Date: 04.Nov. 2013

Revision: 02

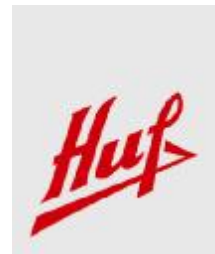

## 10.6 Block diagram

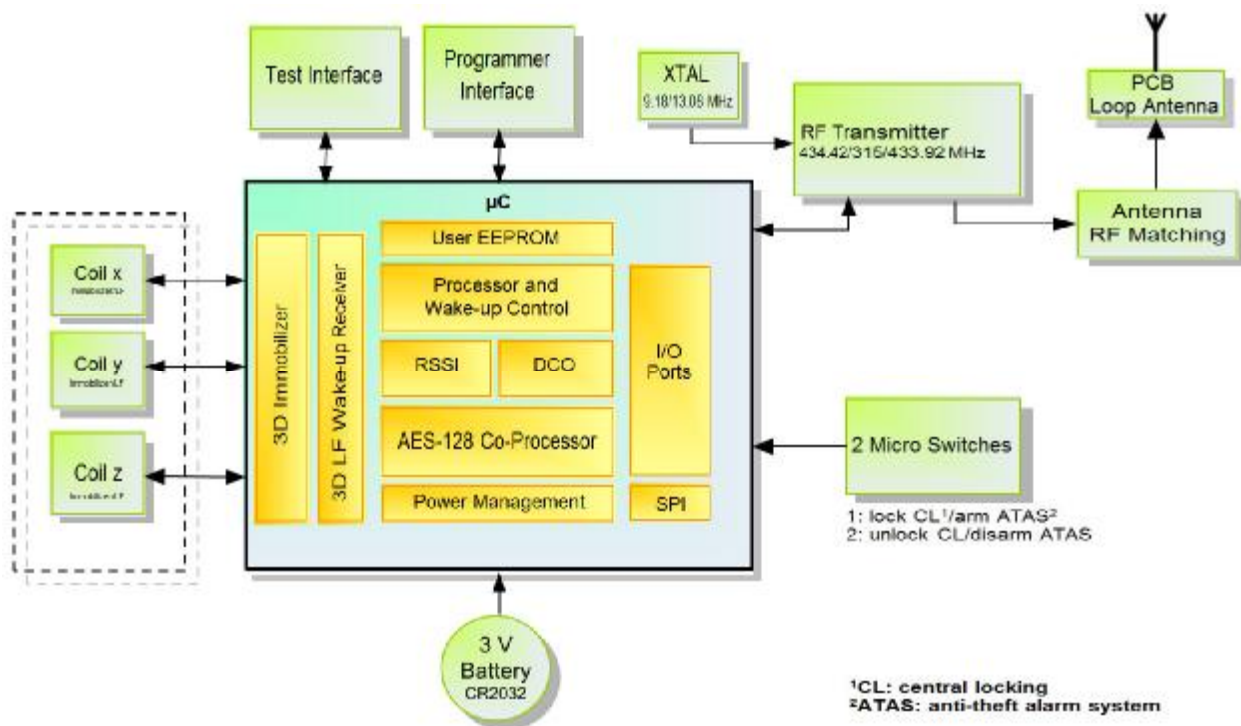

Project designation: Keyless Ride BMW Motorrad

Project numbers: 0905.001 to 0905.004

HUF-authors: L.Patzelt /PDE-H, B.Müller /PDS-CA, D.Steegmann /PDS-PE, u. a.

Date: 04.Nov. 2013

Revision: 02

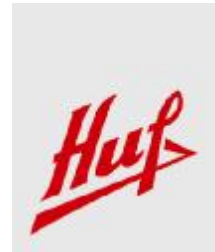

## 10.7 ID device- Models/ Variants

Model	Description
HUF5750	434.42 MHz variant (1 channel) RoW
HUF5752	315.00 MHz variant (1 channel) Japan
HUF5794	433.92 MHz variant (1 channel) South Korea

## 10.8 Technical Data

Carrier frequency model HUF5750:	434.42 MHz
Carrier frequency model HUF5752:	315.00 MHz
Carrier frequency model HUF5794:	433.92 MHz
Output power model HUF5750*:	< -19 dBm (RoW)
Output power model HUF5752**:	< -15 dBm (Japan, TELEC-T244, 315 MHz)
Output power model HUF5794***:	< 3 mW (South Korea)
Type of modulation:	FSK
FSK deviation:	±20 kHz
Method of frequency generation:	PLL
Number of channels:	1
RF baud rate:	7.5 kbps, tolerance ≤0.3 %
LF frequency:	134.2 kHz
LF baud rate:	1,3 kbps, tolerance ≤0.3 %
Immobilizer frequency (uplink):	123.2/134.2 kHz
Crystal unit HUF5750/HUF5794:	13.08148 MHz
Crystal unit HUF5752:	9.185183 MHz
Power supply:	battery (CR2032, coin cell)
Supply voltage:	3.2 V (maximum) 3.0 V (nominal) 2.2 V (minimum)
Type of battery:	Lithium
Type of RF antenna:	PCB Loop antenna
Dimensions:	approx. 64 mm x 34.5 mm x 18.3 mm
Weight:	approx. 42 g
Temperature ranges:	
RKE/PKE:	-20 °C ... +60 °C (due to battery limitations)
Immobilizer:	-20 °C ... +85 °C

Project designation: Keyless Ride BMW Motorrad

Project numbers: 0905.001 to 0905.004

HUF-authors: L.Patzelt /PDE-H, B.Müller /PDS-CA, D.Steegmann /PDS-PE, u. a.

Date: 04.Nov. 2013

Revision: 02

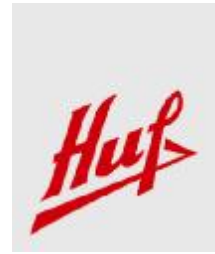

## Technical System Description Keyless Ride BMW Motorrad

### Transmission power EIRP:

- \* Maximum transmission power limit respective to EN300220:  $\leq +10$  dBm and according to FCC part 15 / Canada RSS-210: 3.75 mV/m...12.5 mV/m in the 260 - 470 MHz range at a distance of 3 m.
- \*\* Taken from the new TELEC-T244 Japanese standard  
Limit max. 250  $\mu$ W with transmission frequency of up to 315.00 MHz, this relates to -6 dBm.
- \*\*\* Maximum transmission power limit according to KCC notification 2013-01-03:  
Limit max. 3 mW in the 433.795 MHz - 434.045 MHz range at a distance of 3 m.

### 10.9 Disposal

Old batteries must be lodged at a collecting point or at a service center.

### 10.10 Location of product label

The product labelling with FCC ID and IC certification number can be found below the flipped-in key blade.

### 10.11 Declaration of Conformity, product label of the ID device

#### 10.11.1 Radio equipment authorization to FCC in USA

**FCC ID: YGOHUF5750**

The transmitter will be supplied as an original equipment device to the vehicle manufacturer.

According to 47 CFR 15.19 (labeling requirements) the vehicle manufacturer will print the following text in the appropriate user's manual of the vehicle:

This device complies with Part 15 of the FCC Rules. Operation is subject to the following two conditions:

- (1) This device may not cause harmful interference, and
- (2) this device must accept any interference received, including interference that may cause undesired operation.

Usually this is followed by the following FCC caution:

Any changes or modification not expressly approved by the party responsible for compliance could void the user's authority to operate this equipment.

Project designation: Keyless Ride BMW Motorrad

Project numbers: 0905.001 to 0905.004

HUF-authors: L.Patzelt /PDE-H, B.Müller /PDS-CA, D.Steegmann /PDS-PE, u. a.

Date: 04.Nov. 2013

Revision: 02

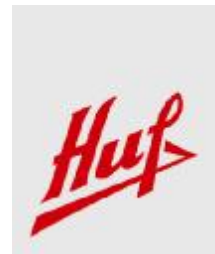

## **10.11.2 Radio equipment authorization to RSS-210 in Canada**

**IC: 4008C-HUF5750**

The transmitter will be supplied as an original equipment device to the vehicle manufacturer.

According to RSS-210 (labeling requirements) the vehicle manufacturer will print the following text in the appropriate user's manual of the vehicle:

Operation is subject to the following two conditions:

- (1) This device may not cause harmful interference, and
- (2) this device must accept any interference received, including interference that may cause undesired operation.

Usually this is followed by the following RSS caution:

Any changes or modification not expressly approved by the party responsible for compliance could void the user's authority to operate this equipment.

Project designation: Keyless Ride BMW Motorrad

Project numbers: 0905.001 to 0905.004

HUF-authors: L.Patzelt /PDE-H, B.Müller /PDS-CA, D.Steegmann /PDS-PE, u. a.

Date: 04.Nov. 2013

Revision: 02