



# Hub Installation and User Manual

1027145-0001

Revision E

March 7, 2000

***For important standards compliance information, see appendix B.***

**Copyright ©1999–2000 Hughes Network Systems, a Hughes Electronics Corporation company**

All rights reserved. This publication and its contents are proprietary to Hughes Network Systems, a Hughes Electronics Corporation company. No part of this publication may be reproduced in any form or by any means without the written permission of Hughes Network Systems, 11717 Exploration Lane, Germantown, Maryland 20876.

Hughes Network Systems has made every effort to ensure the correctness and completeness of the material in this document. Hughes Network Systems shall not be liable for errors contained herein. The information in this document is subject to change without notice. Hughes Network Systems makes no warranty of any kind with regard to this material, including, but not limited to, the implied warranties of merchantability and fitness for a particular purpose.

**Trademarks**

AIReach™ is a trademark of Hughes Network Systems. Other trademarks, marks, names, or product names referenced in this publication are the property of their respective owners, and Hughes Network Systems neither endorses nor otherwise sponsors any such products or services referred to herein.

# Contents

<i>About this manual</i> .....	<i>vii</i>
<i>Important safety information</i> .....	<i>ix</i>
<b>1 Installation summary</b> .....	<b>1-1</b>
1.1 Hub reference drawing .....	1-2
1.2 Installation summary and checklist .....	1-3
<b>2 Prerequisites</b> .....	<b>2-1</b>
2.1 Reviewing site data and plans .....	2-1
2.2 Planning ahead for building access .....	2-2
2.3 Tools needed for installation .....	2-3
2.4 Specialized materials .....	2-6
2.5 Prerequisites for commissioning .....	2-7
<b>3 Installing mast mounts</b> .....	<b>3-1</b>
3.1 Overview .....	3-2
3.2 Roof and ladder safety .....	3-3
3.3 Mount location .....	3-3
3.4 Handling materials .....	3-4
3.5 Roof types .....	3-5
3.6 Mast mount types .....	3-5
3.7 Standard nonpenetrating mount .....	3-6
3.8 Using existing structures as ODU mounts .....	3-13
<b>4 Installing ODUs</b> .....	<b>4-1</b>
4.1 Introduction .....	4-2
4.2 Transporting the ODU .....	4-5
4.3 Determining the HT alignment direction .....	4-6
4.4 Preparing to install the antenna mount .....	4-10
4.5 Installing the antenna mount .....	4-13
4.6 Attaching the antenna to the mount .....	4-15
4.7 Adjusting the antenna azimuth .....	4-18
4.8 Adjusting the antenna elevation .....	4-20
4.9 Making fine adjustments .....	4-22
4.10 Attaching the transceiver to the antenna .....	4-23
4.11 Grounding the ODU .....	4-25

<b>5</b>	<b>Installing IFL cables</b>	<b>5-1</b>
5.1	IFL cable specifications	5-2
5.2	Overview: IFL plan	5-3
5.3	Determining the IFL cable route	5-4
5.4	Penetrating the roof	5-5
5.5	Installing the penetration sleeve	5-6
5.6	Installing the IFL cable inside the building	5-7
5.7	Installing the hub lightning arrestor	5-8
5.8	Installing the IFL cable on the roof	5-13
<b>6</b>	<b>Installing indoor hub equipment</b>	<b>6-1</b>
6.1	Installing the hub rack (optional)	6-2
6.2	Installing IDUs	6-7
6.3	Power supplies	6-11
6.4	Installing the CCM	6-26
6.5	SSIs	6-28
6.6	Connecting the IFL to the CCM	6-33
6.7	Redundancy bus cable	6-34
6.8	Front panel LCD operation	6-35
6.9	CCM power-on test	6-37
6.10	Hub LAN router and LAN hub	6-39
<b>7</b>	<b>Commissioning HTs</b>	<b>7-1</b>
7.1	Prerequisites for commissioning	7-2
7.2	HT commissioning procedure	7-3
7.3	Checking component status	7-7
7.4	HT to RT connection tests	7-11
<b>8</b>	<b>Final steps</b>	<b>8-1</b>
8.1	Weatherproofing	8-2
8.2	Inspection, cleanup, and sign-off	8-3
8.3	Connecting customer equipment	8-3
<b>9</b>	<b>Troubleshooting</b>	<b>9-1</b>
9.1	Troubleshooting flow charts	9-1
9.2	Additional troubleshooting information	9-6
9.3	Repair or replacement service	9-6

<b>10</b>	<b>Maintenance</b> .....	<b>10-1</b>
10.1	Adding or moving SSIs .....	10-2
10.2	Replacing components .....	10-3
10.3	Replacing the ODU .....	10-3
10.4	Replacing the IDU chassis .....	10-8
10.5	Replacing the CCM .....	10-10
10.6	Replacing SSIs .....	10-11
10.7	Replacing the IFL .....	10-12
10.8	Dismantling an HT .....	10-14
<b>A</b>	<b>Acronyms and abbreviations</b> .....	<b>A- 1</b>
<b>B</b>	<b>Standards compliance</b> .....	<b>B-1</b>
B.1	Outdoor unit .....	B-2
B.2	Indoor unit (ac) .....	B-3
<b>C</b>	<b>Terminating IFL cables</b> .....	<b>C-1</b>
C.1	Cable parts and terminology .....	C-2
C.2	Preparing the cable end .....	C-3
C.3	Attaching the connector .....	C-6
C.4	Applying heat-shrink tubing .....	C-11
<b>Index</b>	.....	<i>follows appendix C</i>



# About this manual

---

This manual provides instructions for installing and using AIReach™ Broadband point-to-multipoint equipment at a hub site.

## User qualifications

This manual is intended for use by qualified equipment installers. Installers must understand:

- Electronics fundamentals
- Cabling and connection practices
- Electrical circuits and grounding practices
- The importance of safety precautions

Installers must also be familiar with:

- Radio frequency (RF) fundamentals
- Applicable electrical, building, fire, and safety codes and regulations

**Note:** HNS recommends a team of two installers to install the AIReach Broadband indoor and outdoor equipment.

## Organization

The instructions in this manual are organized according to tasks and are intended to be followed in sequential order.

## Related publications

For site preparation instructions, see:

- *Hub and Remote Terminal Site Preparation Guide*, document number 1027032-0001

For remote terminal installation instructions, see:

- *Remote Terminal Installation and User Manual*, document number 1027144-0001

## HNS- and customer-provided equipment

This manual primarily describes equipment manufactured and/or provided by Hughes Network Systems (HNS), but in some cases also refers to equipment that may be supplied by another vendor. **HNS equipment deliverables are defined in the customer contract.** Some equipment referred to in this manual may be provided by the customer, as stated in the customer's contract.

# Revision record

---

<b>Revision</b>	<b>Date of issue</b>	<b>Scope</b>
A	April 21, 1999	Released for UL approval.
B	June 8, 1999	Added new and updated information.
C	August 9, 1999	Added troubleshooting and maintenance information.
D	December 17, 1999	Updated illustrations; various revisions and additions.
E	March 7, 2000	Added overall installation checklist. Added information for new antenna mount design, and updated various other information.



# Important safety information

---

For your own safety and protection, read this safety section carefully. Keep this safety information where you can refer to it if necessary.

## Types of warnings used in this manual

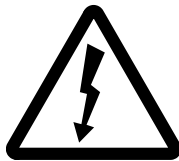
This section introduces the types of warnings used in this manual to alert you to possible safety hazards that could be encountered while installing AIReach Broadband equipment.



### DANGER

**Fall hazard:** Where you see this symbol and DANGER heading, strictly follow the warning instructions to avoid personal injury or death from falling.

---



### DANGER

**Electric shock hazard:** Where you see this symbol and DANGER heading, strictly follow the warning instructions to avoid electric shock injury or death.

---



### WARNING

**Potential radio frequency (RF) hazard:** Where you see this alert symbol and WARNING heading, strictly follow the warning instructions to avoid injury to eyes or other personal injury.

---



### WARNING

Where you see this symbol and WARNING heading, strictly follow the warning instructions to avoid personal injury.

---

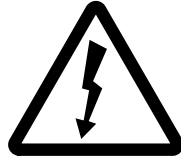
## Warnings appearing in this manual

This manual includes the following safety warnings:



### DANGER

If you have to walk on a roof or use a ladder to access an installation site or equipment, follow these precautions to prevent personal injury or death:



- Do not walk near the edge of the roof.
  - Watch out for overhead power lines. Stay at least 6 meters (20 feet) from power lines.
  - Walk only on sound roof structures.
  - Do not work on a roof or ladder in high wind, rain, lightning, or other adverse weather conditions.
  - Follow all safety precautions from the ladder or antenna manufacturer.
  - Do not walk on a roof if a storm is visible—even if the storm is distant. Lightning can travel and strike in advance of a storm.
- 



### WARNING

If you need to hoist materials to the installation location, observe these precautions to avoid personal injury:

- Use a rope strong enough to support all of the materials that need to be hoisted.
  - Never stand under the rope while materials are being hoisted.
  - Hoist one concrete block at a time.
  - Pass the rope through the *center* hole of each concrete block. If you use the hole on either end, the end can break off, allowing the concrete block to fall.
  - Be advised that the contents of the mount kit can fall through the end of the box if the box is tilted—especially if the box has been damaged.
  - Use a back brace.
-



**WARNING**

Potential radio frequency (RF) hazard:

- Keep away from the front of the outdoor unit (ODU) antenna while the ODU is operating. Note that you cannot tell from outward appearance whether the ODU is operating or not.
- Be careful with respect to the ODU you are installing and ODUs that may already be operating in the installation area.

Failure to observe these warnings could result in injury to eyes or other personal injury.

---



**WARNING**

To help avoid death, injury, or damage from a lightning strike, you *must* install a lightning arrestor where the IFL enters the building.

---



**WARNING**

The optional hub rack weighs approximately 115 pounds (52.2 kilograms) empty. Do not attempt to lift it by yourself. Two people should lift or move the rack, when necessary. Failure to observe this warning could result in personal injury.

---

*The warning immediately below applies only to IDUs with a dual ac or dc power supply:*

---



**WARNING**

Multiple power connectors. Disconnect both ac and dc power before servicing.

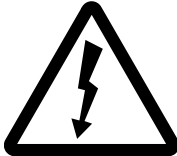
---



**WARNING**

To avoid the risk of electric shock, remove power from the power circuit before connecting power cables to the IDU power supply.

---



**WARNING**

The IDU chassis must be solidly bonded to a low-impedance ground (earth) source. To avoid the risk of electric shock and/or equipment damage, do not apply power to the IDU chassis without a ground reference.

---



**WARNING**

To avoid the risk of electric shock, make sure the dc power source breaker is off before installing a remote power-off circuit. Use a continuity tester to verify that power is off.

---

# Installation summary

---

This chapter includes:

- Hub reference drawing – page 1–2
- HT installation summary – page 1–3

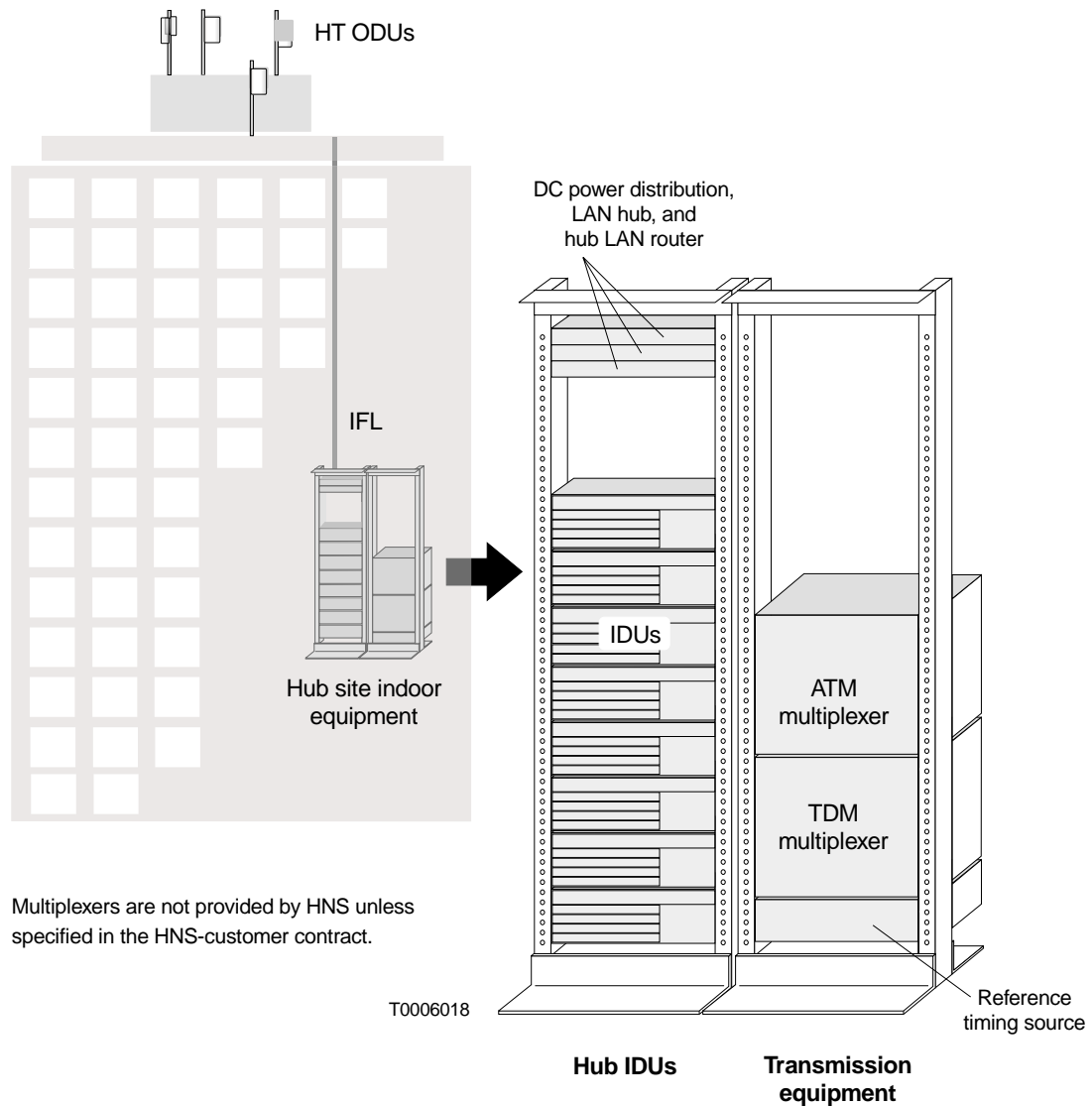
The installation summary previews the entire installation process and serves as a quick reference. For detailed information, see chapters 2 through 8.

**Hub reference drawing**

Figure 1-1 illustrates the main hub components:

- Outdoor units (ODUs)
- Intrafacility link (IFL)
- Indoor units (IDUs)
- Other indoor hub equipment

A hub terminal (HT) consists of an ODU and IDU connected by an IFL. A hub includes at least one HT, but typically includes multiple HTs.



**Figure 1-1 AIReach Broadband hub equipment**

## Installation summary and checklist

### ***Components to be installed***

The following AIReach Broadband components are installed at the hub site:

- ODU(s) – Integrated antenna and transceiver
- IFL
- Indoor unit(s) (IDU), including:
  - IDU channel and control module (CCM)
  - IDU service-specific interfaces (SSIs)
- Optional: hub rack

Transmission equipment such as ATM and TDM multiplexers is available from HNS as an option.

### ***Summary of installation steps***

Installation of HTs at a hub site consists of the following main tasks:

- Install the mast mount – page 3–6
- Determine the HT alignment direction – page 4–6
- Install antenna mount – page 4–13
- Attach the antenna to the mount – page 4–15
- Adjust the antenna azimuth – page 4–18
- Adjust the antenna elevation – page 4–20
- Attach the transceiver to the antenna – page 4–23
- Ground the ODU – page 4–25
- Determine the IFL cable route – page 5–4
- Install the IFL cable (inside the building) – page 5–7
- Install IFL lightning arrestor – page 5–8
- Ground the lightning arrestor – page 5–12
- Install the IFL cable (on the roof) – page 5–13
- Test the IFL cable – page 5–15

- Connect the IFL cable to the ODU – page 5–15
- Install the hub rack (optional) – page 6–2
- Ground the rack – page 6–6
- Install indoor unit (IDU) – page 6–7
- Connect power supply – page 6–11
- Ground the IDU chassis (if required) – page 6–14 (ac) or 6–17 (dc)
- Install CCM – page 6–26
- Install SSIs – page 6–28
- Connect IFL to the CCM – page 6–33
- For each IDU, repeat steps on pages 6–7 through 6–33.*
- Install CCM redundancy bus cable (if backup HT is present) – page 6–34
- Conduct CCM power–on test – page 6–37
- Check component status – page 7–7
- Verify prerequisites for commissioning – page 7–2
- Perform commissioning steps – page 7–3
- Test HT to RT connections (if possible) – page 7–11
- Weatherproof connections – page 8–2
- Obtain customer signoff – page 8–3

For detailed installation instructions, see chapters 2 through 8.



## Chapter 2

# Prerequisites

---

This chapter discusses steps that are required prior to installation of AIReach Broadband™ hub equipment. It includes the following sections:

- Reviewing site data and plans – page 2–1
- Planning ahead for building access – page 2–2
- Tools needed for installation – page 2–3
- Prerequisites for commissioning – page 2–7

### 2.1

---

#### Reviewing site data and plans

Before you begin installing the equipment, review all previously collected site data and site plans for information you will need to install the indoor and outdoor equipment, including the IFL (intrafacility link). For more information on the equipment to be installed, see section 1.2.

Review:

- The completed Site Data Record from the *Hub and Remote Terminal Site Preparation Guide* – The Site Data Record is completed during and after the pre-installation site survey. It includes the site address, hub terminal (HT) alignment for each sector, IFL information, and much other information.
- Site drawings and photographs, including hub network schematic and hub rooftop drawing – These should include information about the site environment; existing equipment and building features; equipment to be installed; location of ODUs, IDUs, hub rack (if used), and the hub LAN router; IFL routing; customer equipment to be connected to AIReach Broadband equipment; equipment ID numbers; and other information.
- *Planning the ODU location*, a section in the *Hub and Remote Terminal Site Preparation Guide* – The ODU location should already be selected; however, this section contains information that is useful for the installer to know.

---

## Planning ahead for building access

Before you go to the installation site, **make sure you have all necessary information (such as contact names and phone numbers) for accessing all parts of the building you will need to visit** (roof, equipment rooms—which may be in the basement, and other locations). This information should be available in the Site Data Record, which is completed as part of the site survey.

*Recommendations:*

- Know who to contact for assistance (name, phone number, working hours).
- Get good directions or a building map or floor plan, if possible.
- You may need a key or pass code to gain access to the roof.
- Make all necessary arrangements for facility support and building access *before you go to the installation site.*

## Tools needed for installation

To install and commission AIReach Broadband hub equipment, you need the tools listed in table 2-1 . You may need general-purpose tools in addition to the specific tools listed here.

**Table 2-1 Tools required for HT installation**  
(includes tools for IFL installation, antenna alignment, and initial testing)

√	Item	Purpose (or other comments)
<input type="checkbox"/>	Ladder	May or may not be required; depends on building
<input type="checkbox"/>	Rope	To hoist tools and equipment up ladders. Rope must be long enough for ladders at the site. Must be able to hold <i>at least</i> 35 pounds (16 kilograms). This is the ODU weight. IFL cable is likely to weigh more.
<input type="checkbox"/>	Snow shovel or heavy-duty push broom	To move roof gravel away from the ODU installation site
<input type="checkbox"/>	1/2-inch drill	Cordless drill preferred for work on roof. Drill with power cord required for heavy-duty work (such as mounting a rack to the floor).
<input type="checkbox"/>	Drill with bits for wood and masonry.	May be needed for IFL installation
<input type="checkbox"/>	Combination wrenches: 7/16 inch, 9/16 inch 10 millimeter, 13 millimeter	For installing the mast mount and antenna mount
<input type="checkbox"/>	Ratchet wrench with 9/16-inch socket	For installing the mast mount
<input type="checkbox"/>	3/8-inch torque wrench with 13-millimeter deep socket	Required for installing the antenna mount
<input type="checkbox"/>	5/32-inch (4-millimeter) hex key wrench	To loosen/tighten set screws in antenna bracket. (Required if you need to change the bracket orientation to left or right.)
<input type="checkbox"/>	No. 6 Phillips screwdriver	Needed to attach IDU chassis mounting ears if IDU chassis is rack mounted
<input type="checkbox"/>	1000° heat gun	For applying shrink wrap tubing to protect cable terminations
<input type="checkbox"/>	Cable cutters	

**Table 2-1 Tools required for HT installation – Cont’d.**  
(includes tools for IFL installation, antenna alignment, and initial testing)

√	Item	Purpose (or other comments)
<input type="checkbox"/>	Diagonal cutters (wire cutters)	
<input type="checkbox"/>	Flush mount cutters	
<input type="checkbox"/>	Excelta CX-1-78-1 cable stripping tool	Manufacturer: Excelta Corp., Buellton, CA
<input type="checkbox"/>	Crimp tool for #2 and #6 AWG ground lugs	Manufacturer: Thomas & Betts, Memphis, TN
<input type="checkbox"/>	HCT-231 crimp tool	For terminating N-type connectors
<input type="checkbox"/>	Channel locks	
<input type="checkbox"/>	Soft jaw pliers	Grip tool with soft surface, for gripping and turning N-type connectors
<input type="checkbox"/>	Band cutters	To remove shipping bands from mast mount pieces
<input type="checkbox"/>	Carpenter's knife	
<input type="checkbox"/>	Splicer's knife	To terminate cables
<input type="checkbox"/>	Flashlight	Primarily for IFL installation
<input type="checkbox"/>	100-foot tape measure (metric equivalent: 30.5 meters)	For measuring cable runs
<input type="checkbox"/>	Large backpack or padded bag	To haul ODU transceiver and antenna to the roof
<input type="checkbox"/>	Detailed local map	Used to align HT antennas. Must show true north, streets, buildings, and landmarks. Helpful if the map shows magnetic declination (or magnetic north versus true north). A U.S. Geological Survey map is recommended. A travel map will suffice if it shows sufficient detail.
<input type="checkbox"/>	Ruler or straight edge	For antenna alignment; used to mark directions on map
<input type="checkbox"/>	Pencil or broad-tip pen	For antenna alignment; used to add markings to local map

**Table 2-1 Tools required for HT installation – Cont’d.**  
 (includes tools for IFL installation, antenna alignment, and initial testing)

√	Item	Purpose (or other comments)
<input type="checkbox"/>	Protractor	Used to align antenna. Must show 0° increments from 0° to 180°.
<input type="checkbox"/>	Compass	Used as an aid in aligning the antenna. Must be accurate to within ±1°
<input type="checkbox"/>	Chalk or other marker	For antenna alignment; to mark lines on the roof
<input type="checkbox"/>	Optional: Chalked plumb line (the type you snap to leave a straight chalk line)	For antenna alignment; to mark lines on the roof
<input type="checkbox"/>	Inclinometer	Used to set antenna elevation
<input type="checkbox"/>	Personnel safety lines	For safety on roof
<input type="checkbox"/>	Back brace	To protect against back injury while hoisting or lifting equipment and installation materials
<input type="checkbox"/>	Test set(s) (DS1, DS3, or both)	For commissioning tests. Test set type(s) needed depends on services the hub supports (DS1, DS3, or both).

**Note:** Vendor names, model numbers, and part numbers identify equipment known to be suitable. Other comparable equipment may also be suitable.

## 2.4

### Specialized materials

To install AIReach Broadband HT equipment, you will need the materials listed in table 2-2 . This is a list of key, mostly specialized materials. *It is not a comprehensive list.* In addition to the listed materials, installers should carry materials that are commonly required to install outdoor telecommunications equipment.

**Table 2-2 Specialized materials required for RT installation**

√	Item	Purpose (or other comments)
<input type="checkbox"/>	IFL cable	For specifications, see page 5–2.
<input type="checkbox"/>	Ground cable	IDU, ac (if not grounded through the power cable): No. 16 AWG, green IDU, dc: No. 14 AWG, green ODU and lightning arrestor: No. 6 AWG or greater, green For rack installations (rack to ground bar): No. 2 AWG, green, stranded, and shielded
<input type="checkbox"/>	N type connectors	N connectors, for IFL cable, see page 5–3.
<input type="checkbox"/>	Concrete blocks	Used to anchor mast mount. For details, see section 3.7 on page 3–6.
<input type="checkbox"/>	Weatherproofing compound	Used to seal outdoor IFL connections. See section 8.1 on page 8–2.
<input type="checkbox"/>	Outdoor waterproof tape	Used to seal outdoor IFL connections. See section 8.1 on page 8–2.

---

## Prerequisites for commissioning

You will not be able to commission HTs (as detailed in chapter 7) unless the Element Management System (EMS) is operational. Specific requirements for commissioning are:

- The EMS hardware and software must be installed and operational.
- The EMS database must be loaded and operational.
- The EMS operator has to enter the hub MAC address into the EMS database.

*Additional prerequisites for commissioning are listed in chapter 7. The additional prerequisites are satisfied when the HT is properly installed. **The prerequisites listed above must be accomplished prior to HT installation—or commissioning will be delayed until they are accomplished.***

# Installing mast mounts

---

This chapter includes:

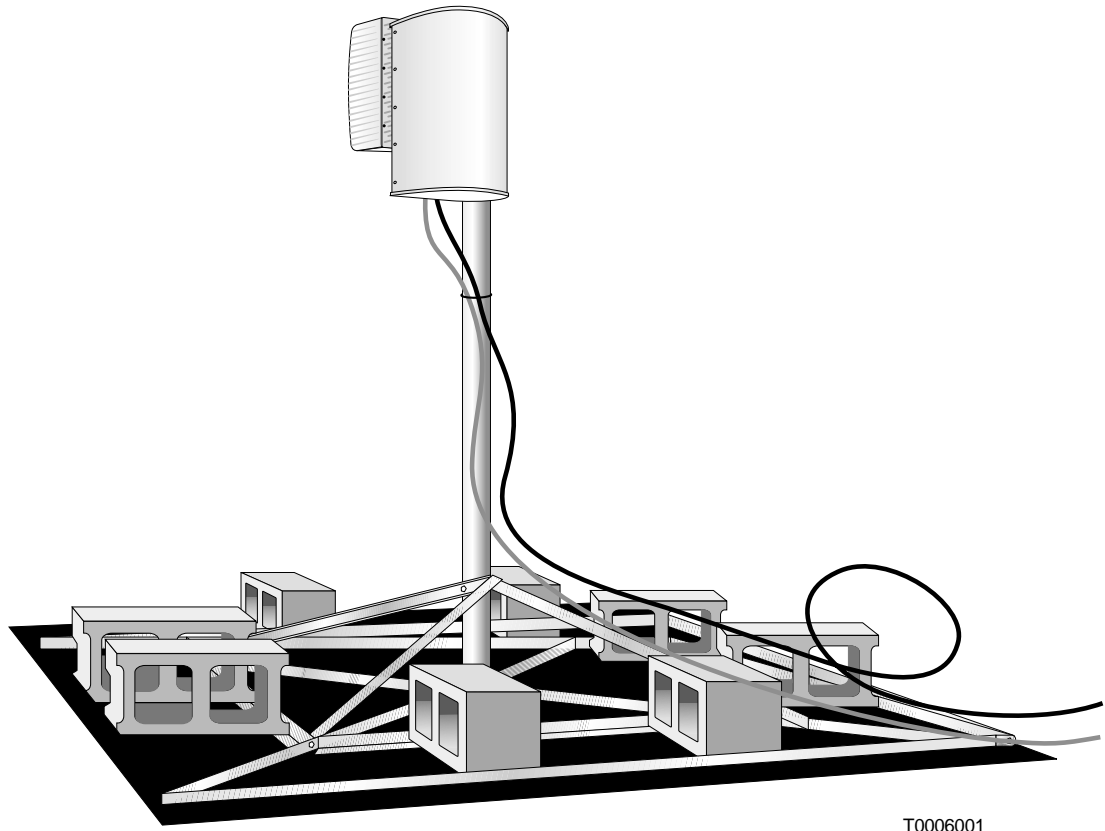
- Overview – page 3-2
- Roof and ladder safety – page 3-3
- Mount location – page 3-3
- Handling materials – page 3-4
- Roof types – page 3-5
- Mast mount types – page 3-5
- Standard nonpenetrating mount – page 3-6
- Existing structures – page 3-13



**Overview**

Typically, the installers assemble a nonpenetrating roof mount for each ODU to be installed. In some cases, a different type of mast mount may be used, or an existing structure may be used.

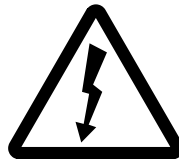
The mount supports the mast in a vertical position, and the ODU is mounted on the mast, as shown in figure 3-1.



T0006001

**Figure 3-1 Mast mount supporting mast and ODU**

## Roof and ladder safety



### DANGER

If you have to walk on a roof or use a ladder to access an installation site or equipment, follow these precautions to prevent personal injury or death:

- Do not walk near the edge of the roof.
- Watch out for overhead power lines. Stay at least 6 meters (20 feet) from power lines.
- Walk only on sound roof structures.
- Do not work on a roof or ladder in high wind, rain, lightning, or other adverse weather conditions.
- Follow all safety precautions from the ladder or antenna manufacturer.
- Do not walk on a roof if a storm is visible—even if the storm is distant. Lightning can travel and strike in advance of a storm.

## Mount location

Site preparation personnel specify the ODU location as part of preparing the hub rooftop drawing.

1. Use the hub rooftop drawing to determine where to install the mount (at the ODU location) and locate the IFL entry point.
2. Make sure the roof penetration or entry point for the IFL is suitable.

**Important:** The location(s) used for ODU installation must meet the requirements listed in the *Hub and Remote Terminal Site Preparation Guide*. Key considerations include:

- Line of sight
- IFL entry location
- Sources of interference
- Safety
- Ground point location
- Access
- Security

For details, see the *Site Preparation Guide*.

---

## Handling materials

Depending on the installation location, you may have to hoist the mount kit, ballast (concrete blocks), IFL cable, and tools to the rooftop as shown in figure 3-2. Using two or more people for this task will save considerable time.



T0006060

Figure 3-2 Hoisting materials to the installation location



### WARNING

If you need to hoist materials to the installation location, observe these precautions to avoid personal injury:

- Use a rope strong enough to support all of the materials that need to be hoisted.
- Never stand under the rope while materials are being hoisted.
- Hoist one concrete block at a time.
- Pass the rope through the *center* hole of each concrete block. If you use the hole on either end, the end can break off, allowing the concrete block to fall.
- Be advised that the contents of the mount kit can fall through the end of the box if the box is tilted—especially if the box has been damaged.
- Use a back brace.

---

If possible, avoid hoisting the ODU transceiver and antenna on a rope. If possible, carry these components in a backpack or padded bag.

## 3.5

---

### Roof types

Many roof types are suitable for AIReach Broadband ODU installations. Mount installation procedures for the following common roof types are described later in this chapter:

- Rubber cap sheet/glued rubber cap sheet
- Loose gravel on rubber cap sheet
- Corrugated metal

The roof type is a factor in the type of mast mount selected. Also, some mount installation steps may be different, depending on the roof type.

## 3.6

---

### Mast mount types

The following options are available for mounting a mast to support the ODU:

- **Nonpenetrating roof mount** – This mount, essentially a flat platform assembled from a kit, is suitable for most applications. It can be used on various flat roof types. For details, see section 3.7.
- **Existing structure** – An existing structure such as an antenna tower can be used as a mast, or a mast can be mounted to the structure, if the structure meets the requirements given in the *Hub and Remote Terminal Site Preparation Guide*.

## Standard nonpenetrating mount

The standard nonpenetrating roof mount, HNS 9200375-0001, is a flat, metal-frame mount assembled from a kit. It requires a 6.5-by-6.5-foot space (1.98 by 1.98 meters) and includes a 7-foot (2.1-meter) mast. You install the mount on a rubber pad; concrete blocks are added for ballast.

The standard mount can be used on a variety of flat roof types, as detailed below.

Instructions are given below for various types of roofs. See also the manufacturer's instructions, which are included in the mount shipping carton.

### Flat roof – rubber sheet (with or without gravel)

Most flat roofs are topped with:

- Glued rubber cap sheet *or*
- Rubber cap sheet with gravel

Follow these instructions for either type of roof:

1. If the cap sheet is covered with gravel, use a push broom or snow shovel to clear the gravel from the area where the mount will be installed, as shown in figure 3-3.

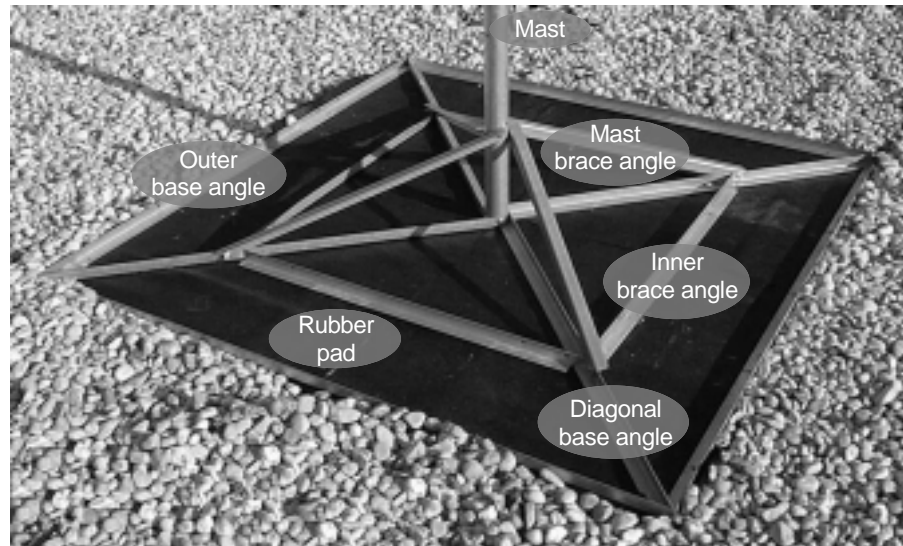


T0006061

**Figure 3-3** Clearing gravel from the installation location

2. Place the rubber pad on the roof surface where the mount will be assembled.

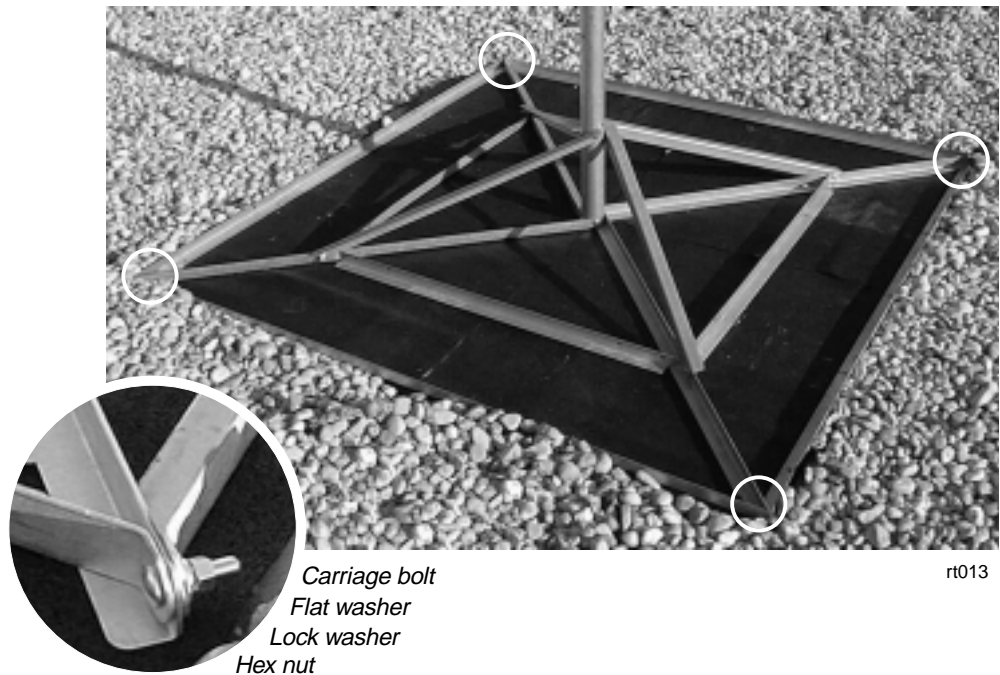
Figure 3-4 identifies the main mount components.



rt015

**Figure 3-4 Mount components**

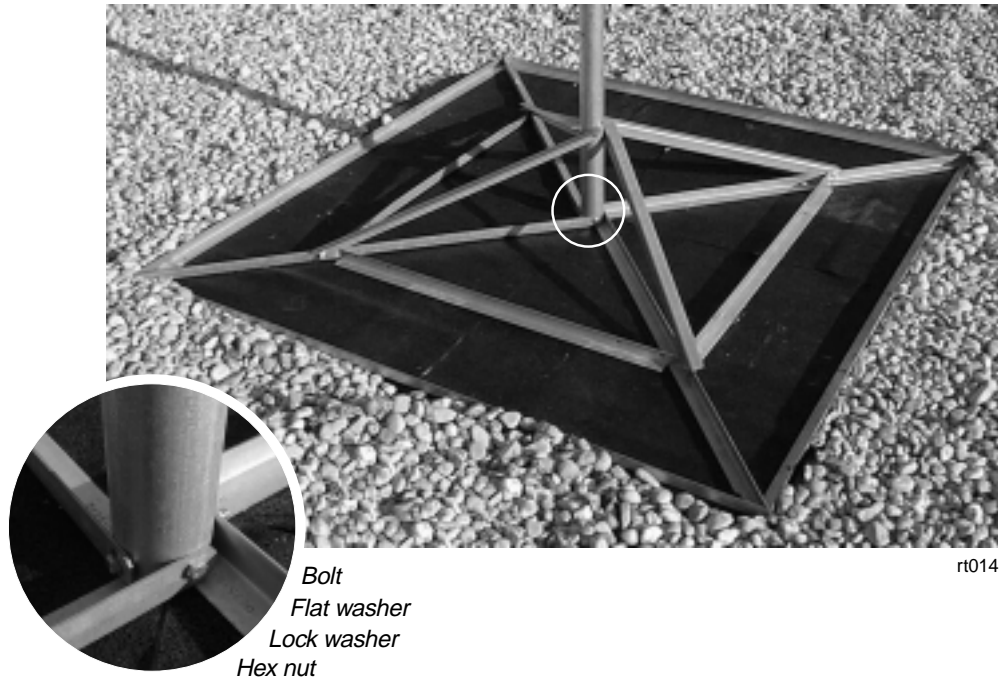
- *Follow steps 3 through 10 to assemble the mount.*
3. Place the mount's four outer base angles on the rubber pad.
  4. Place the mount's diagonal base angles on the rubber pad and connect them to the outer base angles at the locations circled in figure 3-5.



rt013

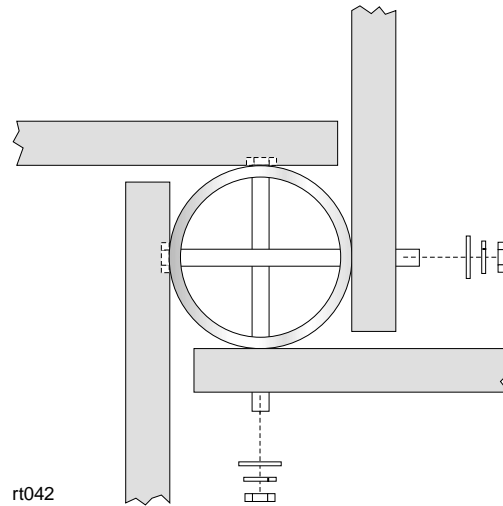
**Figure 3-5 Connecting diagonal base angles to outer base angles**

5. Place the mast between the diagonal base angles. Secure the diagonal base angles to the mast as shown in figure 3-6.

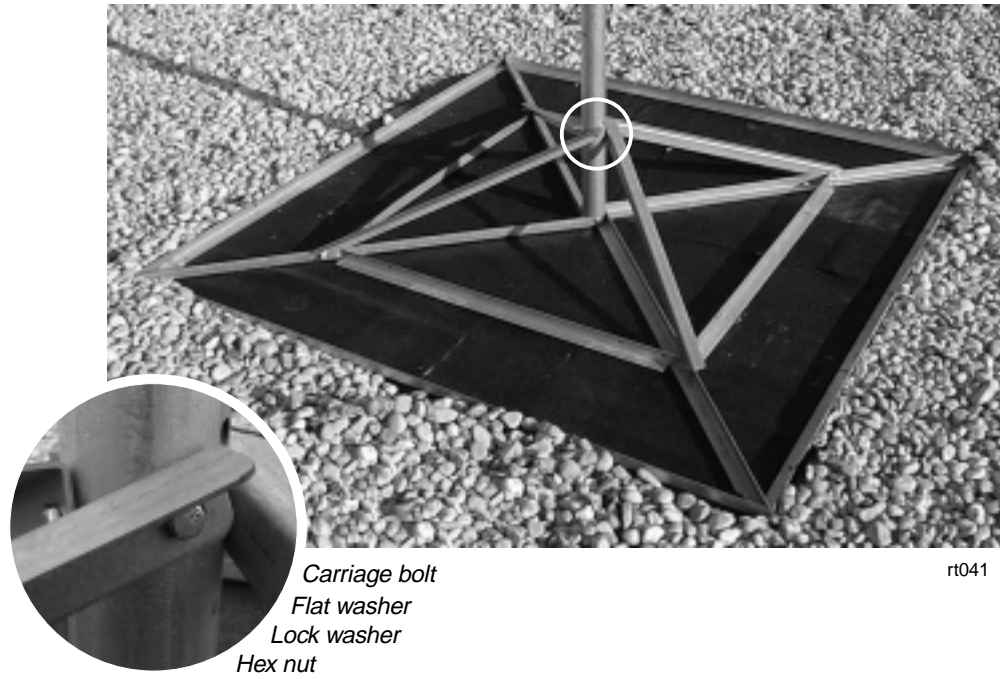


**Figure 3-6 Attaching the diagonal base angles to the mast**

Diagonal base angles opposite each other are secured to the mast with one set of hardware as shown below.

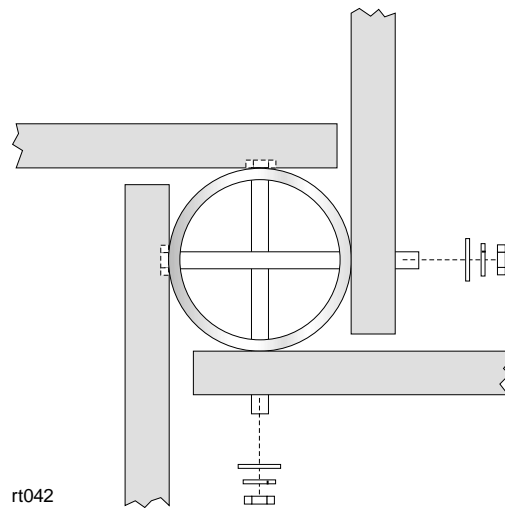


6. Attach the mast brace angles to the mast. See figure 3-7.



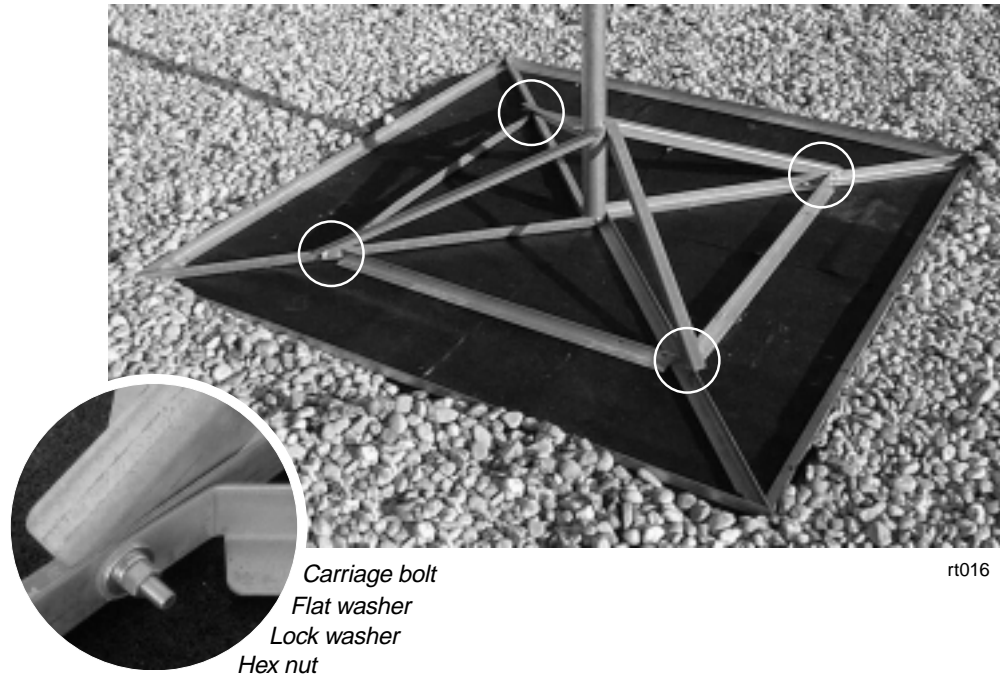
**Figure 3-7 Attaching the mast brace angles to the mast**

Mast brace angles opposite each other are secured to the mast with one set of hardware as shown below.





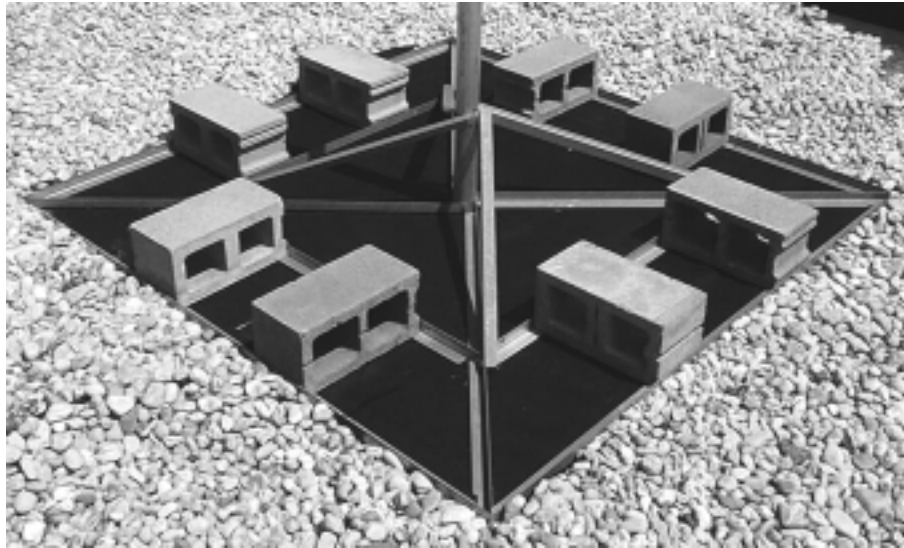
7. Place the inner brace angles on the rubber pad and connect them to the diagonal base angles and mast brace angles as shown in figure 3-8.



**Figure 3-8 Attaching inner brace angles to diagonal base angles and mast brace angles**

8. Refer to the Site Data Record (from the site survey) to determine how many concrete blocks are required to anchor the mount.

9. Place the concrete blocks on the mount so they are evenly spaced, with the ends of each block anchoring both the inner and outer base angles, as shown in figure 3-9.



T0009060

**Figure 3-9 Proper placement of concrete blocks on the mount**

10. When the mount installation is complete, if the roof is covered with gravel, replace gravel up to the outside edges of the mount. See figure 3-9.  
Do not replace gravel in the area inside the mount base.  
Leave the rubber pad exposed.

## **Corrugated metal**

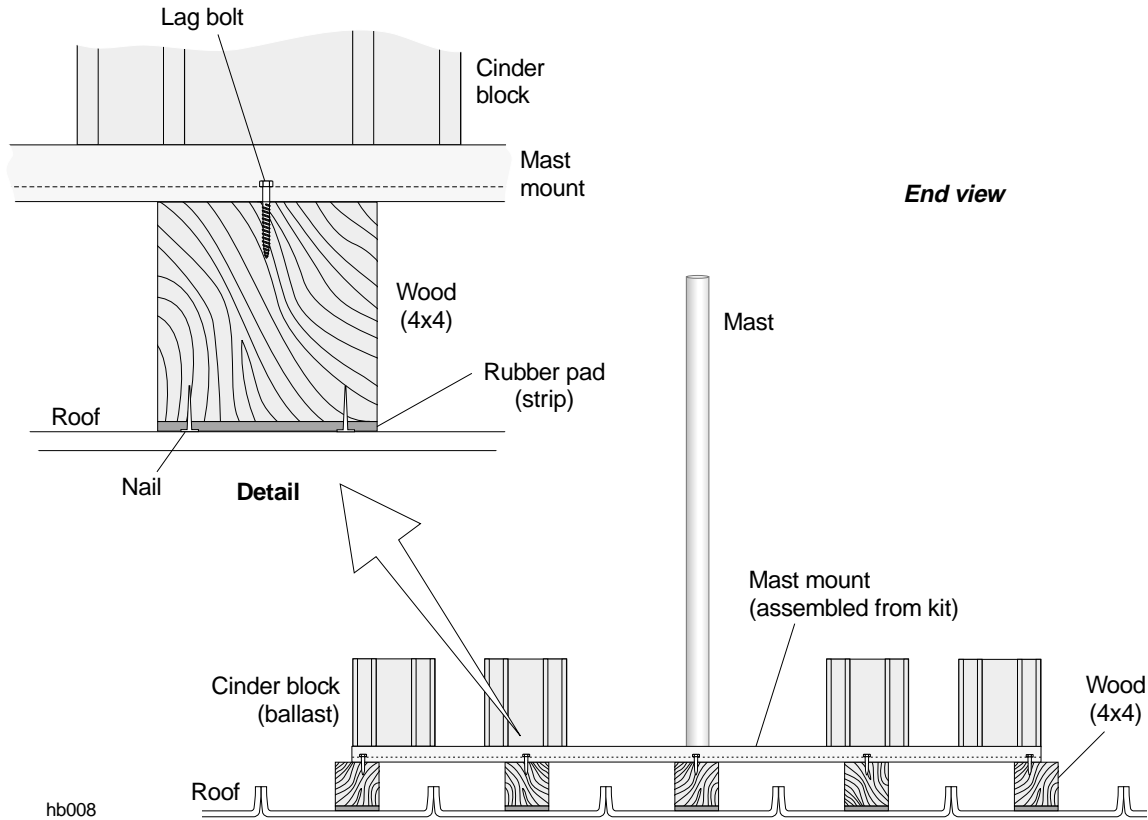
This section explains how to install the standard nonpenetrating roof mount on a corrugated metal roof.

### **Special requirements:**

- Pressure treated lumber, as specified in step 1 below, and
  - Twelve 1-inch-long (2.5-centimeter) lag bolts.
1. Obtain five pieces of pressure treated lumber, each 4 inches by 4 inches by 8 feet long (10 centimeters by 10 centimeters by 2.44 meters long).
  2. **Important:** Select an area of the roof that is supported by a metal I-beam to install the mount.
  3. Cut the rubber pad into strips 4 inches wide by 8 feet long (10 centimeters wide by 2.44 meters long).
  4. Use 5-penny shingle nails to nail one strip of rubber pad to one surface of each piece of lumber. See figure 3-10.

5. Lay out the 4 x 4s, as shown in figure 3-10, so that each piece is:
  - In the recessed portion of the roof
  - Parallel to the raised seams
  - Equally spaced to support the mast, mount braces and sides, and concrete blocks, as shown in figure 3-10.

Lay the lumber with the pad side down, so that the pad is between the roof and the lumber.



**Figure 3-10 Supporting the mount on a corrugated aluminum roof**

6. Follow steps 1 through 10 starting on page 3–6 to assemble the mount.
 

Assemble the mount on the 4 x 4s so that when completed, the mount is elevated above the aluminum roof.
7. Make sure the mount is evenly positioned on the 4 x 4s, then use lag bolts to bolt the mount to the 4 x 4s.
 

Install the bolts through the holes in the mount's outer frame and into the wood. Use one bolt at each end of each piece of lumber (as shown in figure 3-10). Use one bolt at the center of each remaining side of the mount.
8. Add the required number of concrete blocks for ballast. See steps 8 and 9 on page 3–10.

---

## Using existing structures as ODU mounts

In some cases, you may be able to mount an ODU to an existing structure, such as a tower built to support communications antennas.

The key factors for determining if an existing structure can be used as mast are that the structure must:

- Be securely attached to the building (and capable of sustaining specified wind loadings).
- Have an outside diameter of 2.0 to 4.5 inches.
- Meet line of sight (LOS) requirements.

**Important:** *In addition to these criteria, the structure must also meet other requirements listed in the *Hub and Remote Terminal Site Preparation Guide*.*

## Chapter 4

# Installing ODUs

---

This chapter explains how to install ODUs at the hub.  
It includes:

- Introduction – page 4-2
- Transporting the ODU – page 4-5
- Determining the HT alignment direction – page 4-6
- Installing the antenna mount – page 4-13
- Attaching the antenna to the mount – page 4-15
- Adjusting the antenna azimuth – page 4-18
- Adjusting the antenna elevation – page 4-20
- Making fine adjustments – page 4-22
- Attaching the transceiver to the antenna – page 4-23
- Grounding the ODU – page 4-25

*For ODU standards compliance information, see appendix B (page B-2).*

For ODU location requirements, see page 3-3.

## Introduction

For conceptual reference figure 4-1 illustrates how hub terminal (HT) ODUs communicate with remote terminals (RT) ODUs. Typically, multiple HTs are used to provide multiple sectors and achieve coverage up to 360°.

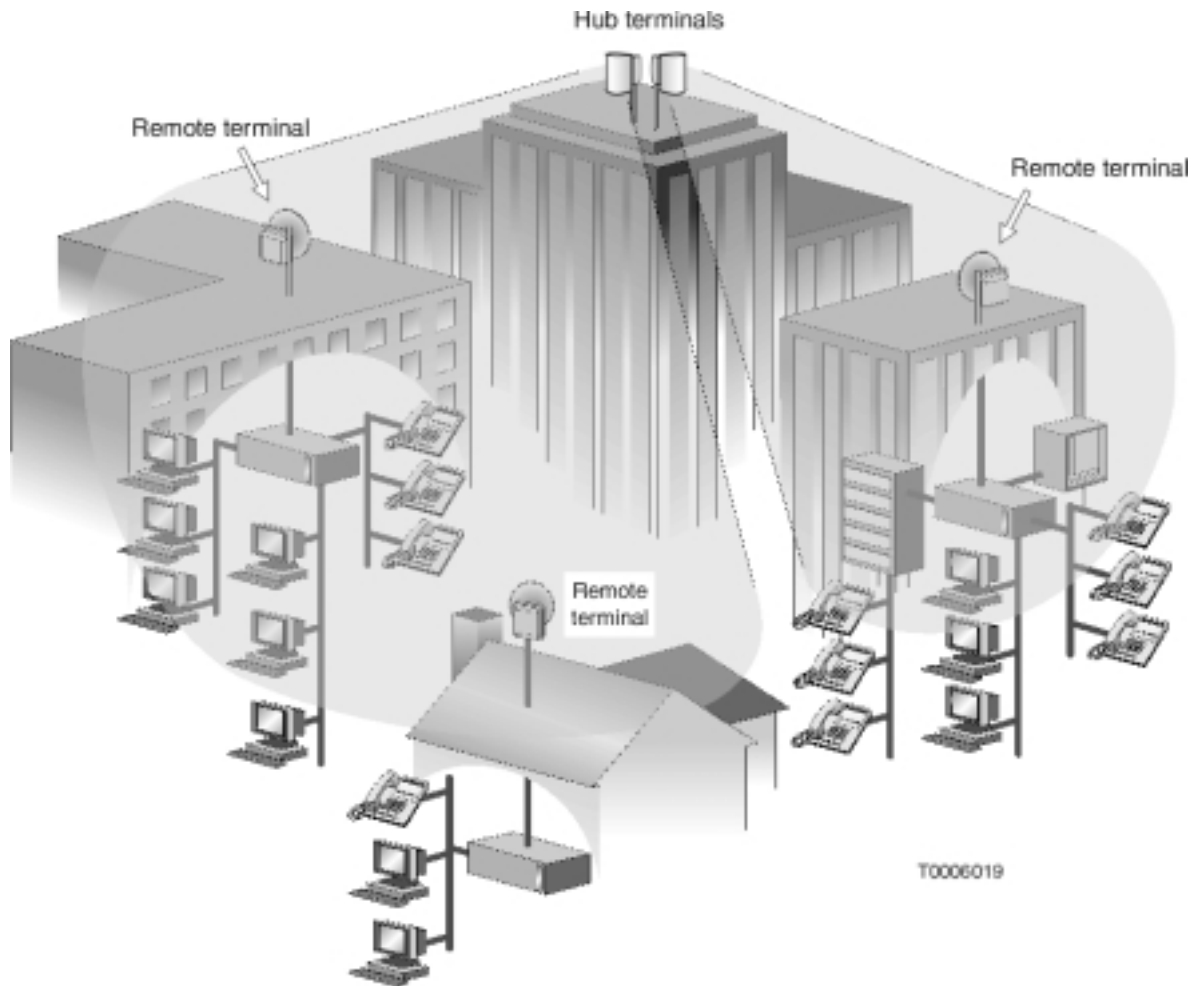
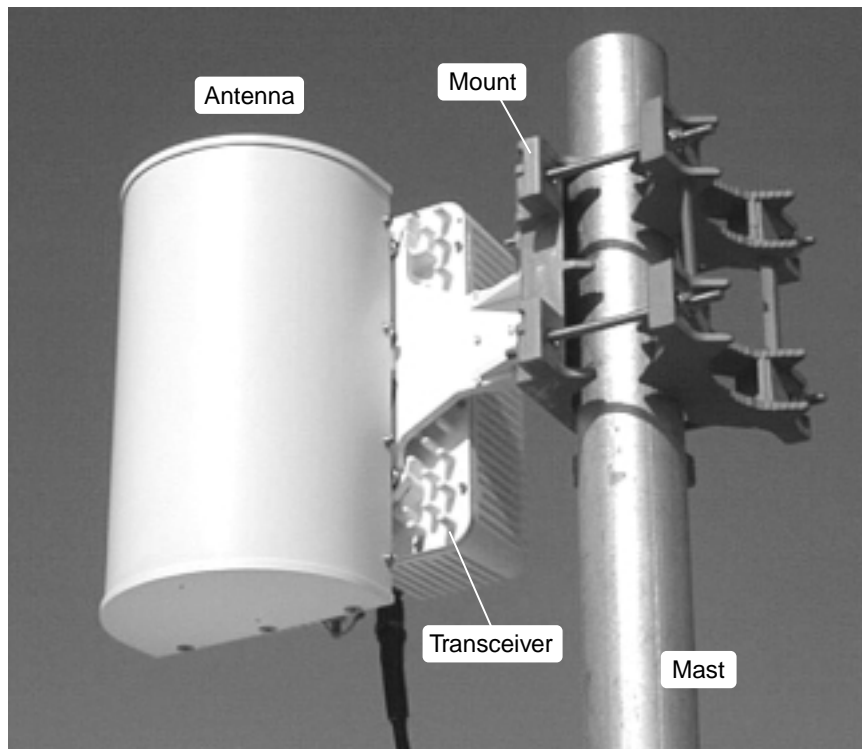


Figure 4-1 Hub ODUs communicating with RT ODUs

The HT outdoor unit (ODU) and integrated antenna attach to a mount installed on a vertical mast, as shown in figure 4-2.



*Some antenna models are larger than the antenna shown here.*

T0006063

**Figure 4-2 HT ODU**

## Safety warnings

When installing ODUs, observe the following safety warnings:



### DANGER

Do not work on a ladder or roof without first reading the safety warnings on page x of this manual. Failure to observe these warnings could result in personal injury or death.

---



### WARNING

Potential radio frequency (RF) hazard:

- Keep away from the front of the outdoor unit (ODU) antenna while the ODU is operating. Note that you cannot tell from outward appearance whether the ODU is operating or not.
- Be careful with respect to the ODU you are installing and ODUs that may already be operating in the installation area.

Failure to observe these warnings could result in injury to eyes or other personal injury.

---



## Prerequisites

Before you can install the outdoor equipment, the mast must be installed.

The mast must have an outside diameter of 2.0 to 4.5 inches (5.0 to 11.4 centimeters) and must be securely mounted in a vertical or horizontal position. **If the mast is not installed, you will need to install it before you proceed.** For additional details concerning the mast, see the *AIReach Broadband Hub and Remote Terminal Site Preparation Guide*.

Before starting, make sure you have:

- Antenna mount
- Antenna
- Transceiver
- 3/8-inch torque wrench with 13-millimeter deep socket
- 5/32-inch (4-millimeter) hex key wrench

You will also need the following tools to plot HT alignments:

- Detailed local map – Must show true north, streets, buildings, and landmarks. It is helpful if the map shows magnetic declination, or magnetic north versus true north. A U.S. Geological Survey map is recommended. A travel map will suffice if it shows sufficient detail.
- Ruler or straight edge
- Protractor with markings from 0° to 180°.
- Pencil or broad-tip pen
- Compass
- Chalk or other marker to mark lines on the roof
- Optional: chalked plumb line (the type you snap to leave a straight chalk line)

## 4.2

---

### Transporting the ODU

Unpack the ODU transceiver and antenna before going up to the roof. Carry the transceiver and antenna to the roof (in separate trips) in a backpack or padded bag. Make sure the transceiver or antenna is secured in the backpack or bag.

## Determining the HT alignment direction

To install and align the ODU, you must know the assigned HT alignment direction *and know where this direction is relative to the HT location*. Plot the planned sectors on a local map as explained in this section—then you will know the alignment direction for each HT to be installed.

1. Obtain the HT alignment direction for each HT to be installed (for example, 45°, 135°, and so on) from the Site Data Record (prepared by the site survey team).
2. Find true north on the map.
3. Find the hub site on the map, and clearly mark its location.
4. Carefully plot lines for true north (0°), south, east, and west, with the hub site at the intersection, as shown in figure 4-3 (page 4–7).
5. Plot the assigned alignment direction for each sector, and identify the sectors, using figure 4-3 as an example.

Figure 4-3 shows four sectors for 90° ODUs. Sectors for 45° or 22.5° ODUs are 45° and 22.5° wide, respectively. In some cases, a full 360° coverage range is not required.

6. On the roof, determine where true north is. You may be able to determine true north using only the map and landmarks.

**If you use a compass to determine magnetic north, you must adjust for magnetic declination (deviation from true north) to determine true north.** Some maps show magnetic declination; some show magnetic north versus true north.

If you are west of the north–to–south line where declination is 0°, the declination is east (or positive). If you are east of the 0° declination line, the declination is west (or negative).

To correct a magnetic compass reading to true north, subtract east (positive) declination values from the magnetic north reading. Add west (negative) declination values. For example:

- If the declination is east, 14°, subtract 14° from the magnetic reading.
- If the declination is west, –14°, add 14° to the magnetic reading.

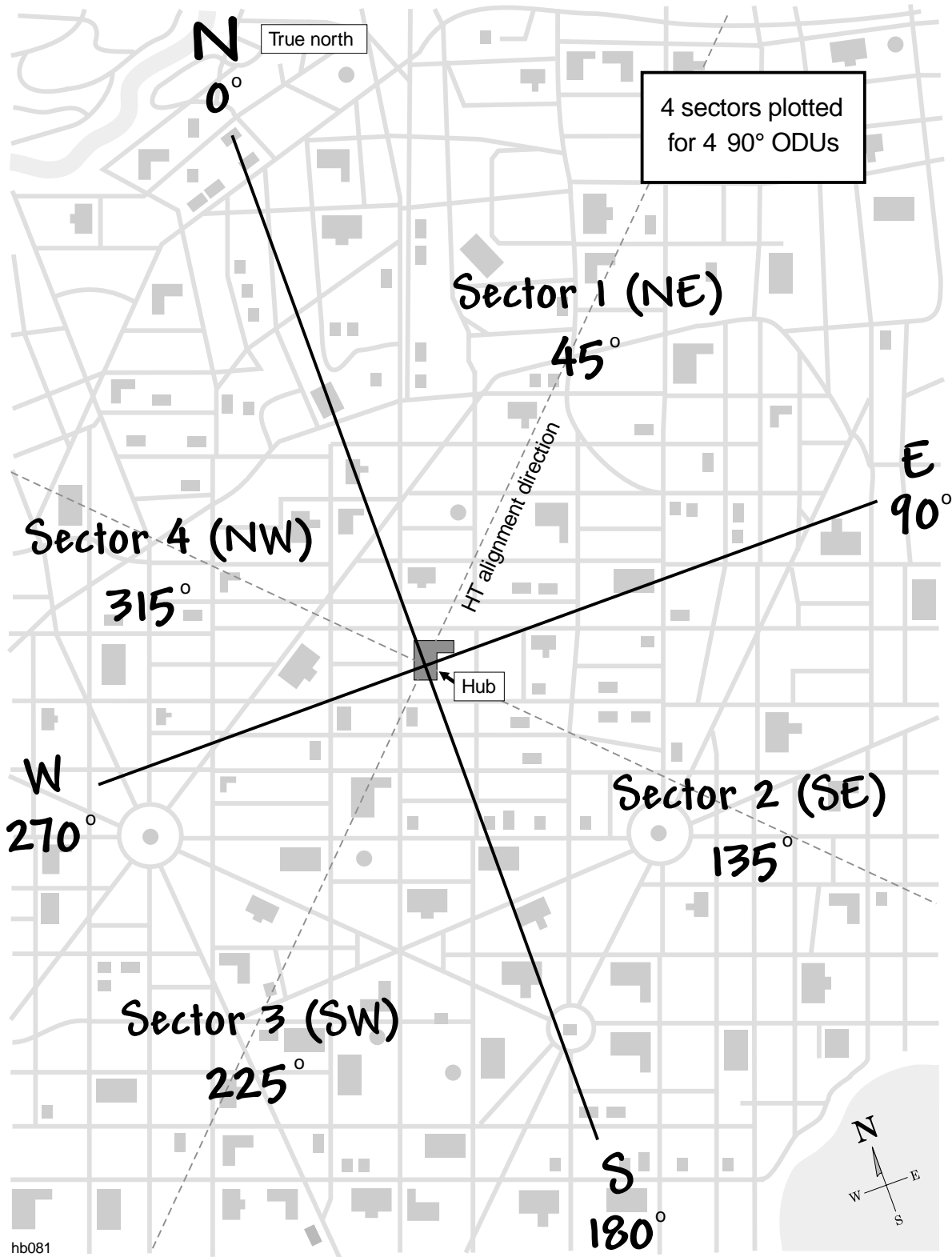


Figure 4-3 Example: Sectors and HT alignment directions plotted on a local map

Magnetic declination changes over time, so use only current declination values.

A compass on a roof may be unreliable, due to metal reinforcing rods in concrete and other metal. Stay away from metal if possible. Take several readings. If readings are not consistent, take readings on the street and mark true north (accounting for declination) on the street where you can see it from the roof. **Use a compass only for verification; do not rely on a compass alone to align the antenna.**

It may be helpful to mark true north, south, east, and west on the roof using a chalked plumb line or some other marking method.

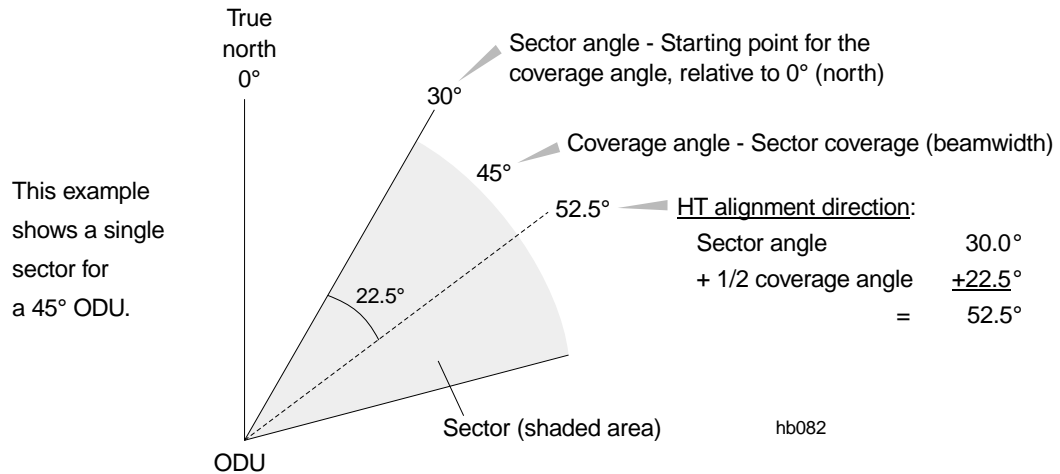
Once you know true north ( $0^\circ$ ) you can easily determine south, east, and west (at  $90^\circ$  intervals), as shown in figure 4-3. You can use the map, protractor, and landmarks to determine any other direction (angle) on the map or with respect to the actual site.

With true north, south, east, and west known, you can align all HTs at the hub site. You could align them on the basis of true north alone, but knowing the other three directions is useful for reference and verification.

7. Use the map and landmarks to verify the directions you have determined.
8. Place the protractor on the map, with its  $0^\circ$  (zero degree) mark on true north. Then determine and plot the angle(s) that corresponds to the HT alignment direction(s).

9. Using the map, directional markings you have made on the roof, the protractor, and landmarks, point the center of the antenna toward the HT alignment direction (i.e., toward the center of the sector, or coverage area) as you install the antenna. (See figure 4-4. Installation instructions for the antenna are covered in sections 4.4 through 4.8.)

Each sector is defined by a sector angle and coverage angle, as illustrated in figure 4-4. However, to align the antenna, you only need to know the assigned HT alignment direction.

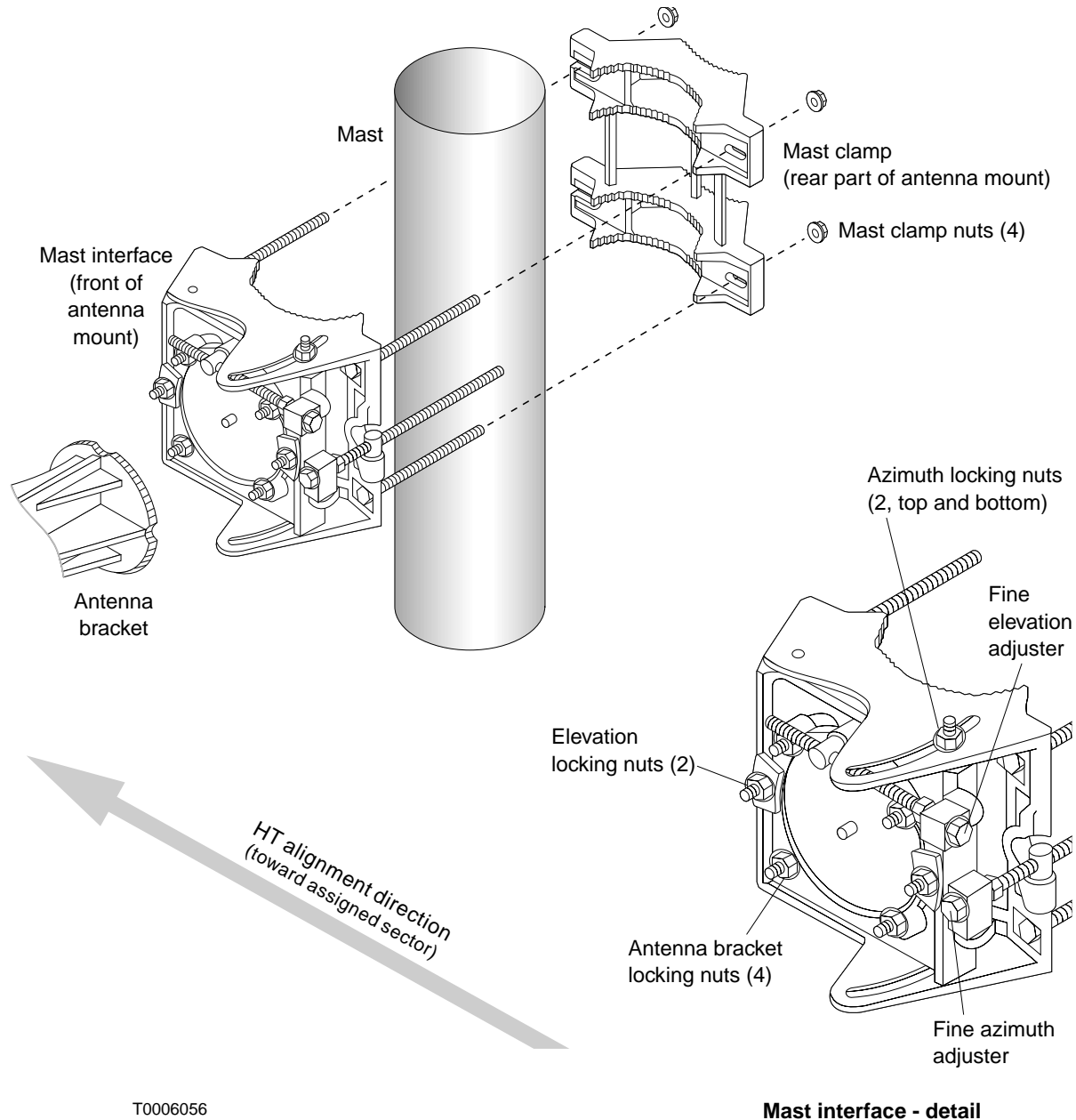


**Figure 4-4 HT sector definition and terminology**

*Keep the sector map and protractor handy. You will use them as you physically install and align the antenna, as explained in the following sections.*

### Preparing to install the antenna mount

The antenna mount (HNS 1029056-0005) is shipped fully assembled. Figure 4-5 shows an exploded view to show all the parts. However, you do not need to take the mount apart to install it, unless you need to reverse the mast clamp. (The mast clamp is reversible, as explained later.)



**Figure 4-5 Antenna mount**

The antenna mount design allows you to install and tighten the mount and antenna and then adjust the antenna azimuth and elevation without loosening the mount or antenna. Parts of the mast interface move to allow these adjustments.

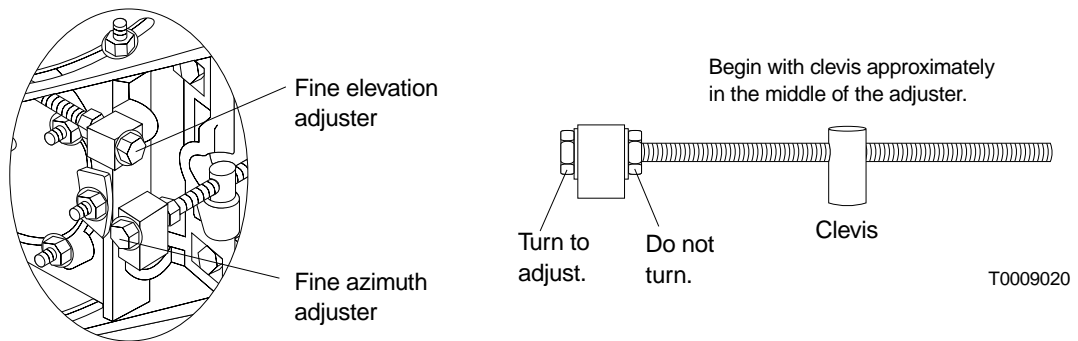
**Important:** To correctly install the antenna mount, read and carefully follow *all* instructions in this section (4.4) through section 4.8.

Prepare the mount for installation:

1. Turn the fine azimuth adjuster as necessary to position the clevis (barrel) approximately in the middle of the threaded part of the adjuster. See figure 4-6.

This step ensures that you will be able to adjust the adjuster as necessary in either direction.

**Do not turn the nut behind the block that holds the fine azimuth adjuster.**



**Figure 4-6 Fine azimuth and elevation adjusters**

2. Turn the fine elevation adjuster as necessary to position the clevis approximately in the middle of the threaded part of the adjuster. See figure 4-6.

**Do not turn the nut behind the block that holds the fine elevation adjuster.**

## ODU height

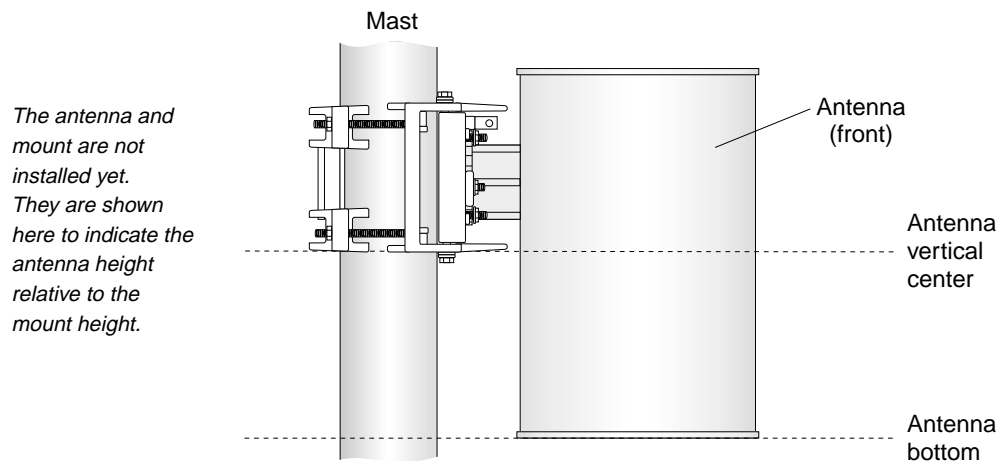
Determine (approximately) how high on the mast to install the mount:

1. Determine the approximate desired ODU/antenna installation height.

Generally, the ODU height is determined as part of the RF survey and is specified in the hub planning documents.

If the ODU height is not specified, install the HT ODU as high as possible. **The ODU/antenna must be high enough to clear any obstructions.**

2. Refer to figure 4-7 for the mount position relative to the position of the (not yet installed) antenna. As shown in figure 4-7, when the antenna is installed (later), the antenna vertical center is approximately at the same height as the bottom of the mount.



T0006032

*Some antenna models may be smaller than the antenna shown here.*

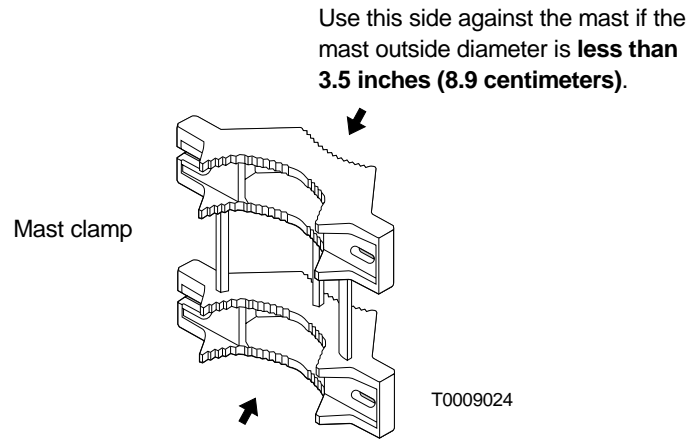
**Figure 4-7 Mount height relative to desired antenna height**



## Installing the antenna mount

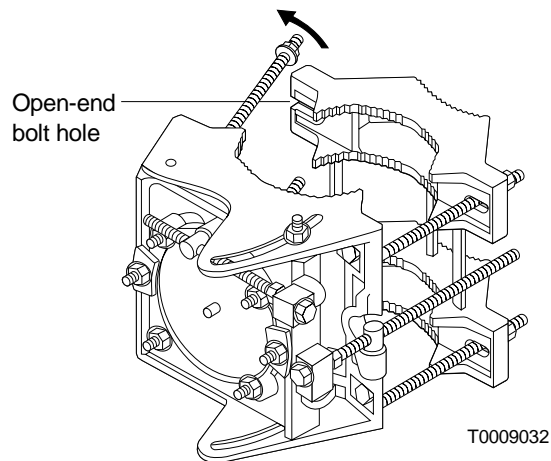
Follow the steps below to install the antenna mount.

1. Determine which side of the mast clamp to use:



Use this side against the mast if the mast outside diameter is **3.5 inches (8.9 centimeters) or larger**.

2. One side of the mast clamp has two open-end bolt holes that allow the long bolts that are attached to the mast interface to swing in or out. See figure 4-8. At the side of the mount where the two open-end bolt holes are, swing the two bolts outward so you can open the mount enough to place it around the mast.



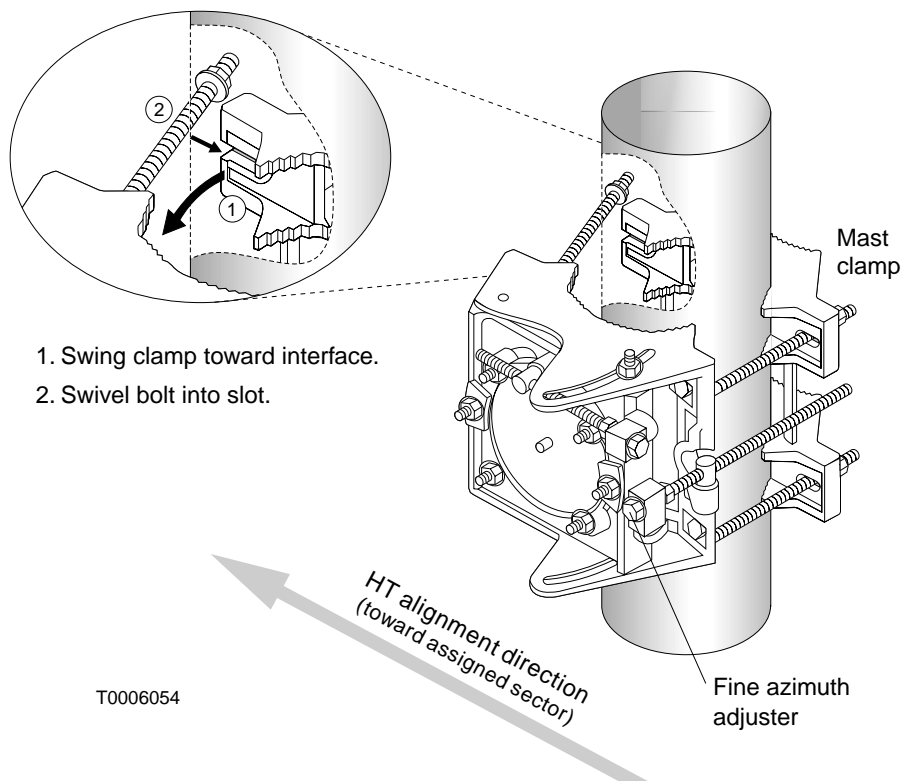
**Figure 4-8** Opening the mount

- Place the mount on the mast, as shown in figure 4-9.  
**The fine azimuth adjuster must be on the side of the mount opposite the HT alignment direction, as illustrated in figure 4-9.** This allows you to make azimuth and elevation adjustments from behind the antenna, so you can stay out of the beam area.

To get the azimuth adjuster on the side opposite the HT alignment direction, you may have to turn the entire mount 180°, depending on whether the ODU will be mounted to the left or right of the mast.

(If you are facing the mast interface—as a reference—it doesn't matter whether the mount swings open to the right or to the left, as long as the azimuth adjuster is opposite the HT alignment direction.)

- Swing the clamp toward the interface until you can “capture” the clamp by swiveling the free–swinging bolts into the two slots in the clamp, as shown in figure 4-9.



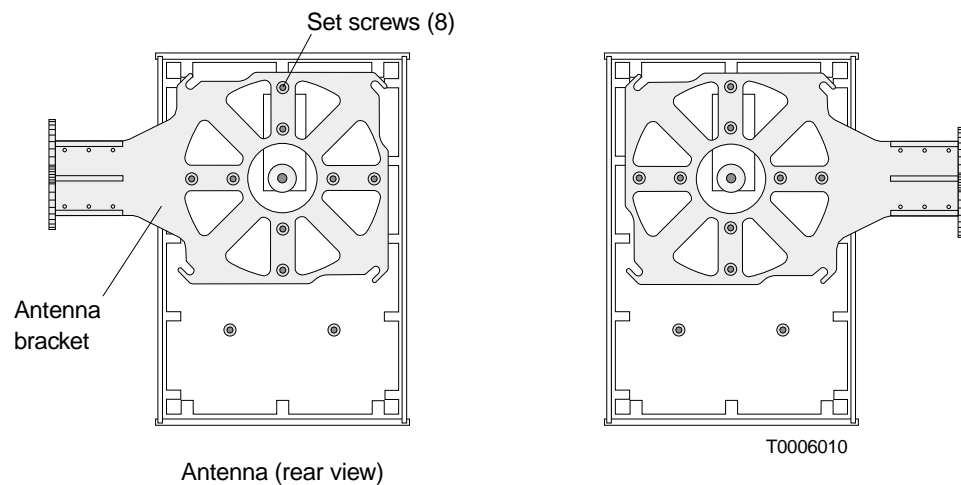
**Figure 4-9** Installing the antenna mount

- Finger tighten** the four mast clamp nuts.  
 Tighten the nuts enough to hold the mount to the mast, but leave them loose enough so you can smoothly pivot the mast interface and mast clamp around the mast to permit coarse azimuth adjustment.  
 (You fully tighten the mast clamp nuts later.)

## Attaching the antenna to the mount

Attach the antenna to the mount:

1. Make sure the antenna is right side up.  
On the back of the antenna is a label with an arrow that points to the top of the antenna. (The label reads “Install antenna this side up.”)
2. The antenna bracket can point to the left or right, as shown in figure 4-10. Before attaching the antenna to the antenna mount, make sure the bracket orientation (to the left or right) is suitable for your installation location. If necessary, you can use a 5/32-inch hex key wrench to remove the eight set screws and reinstall the bracket so it points in the opposite direction.



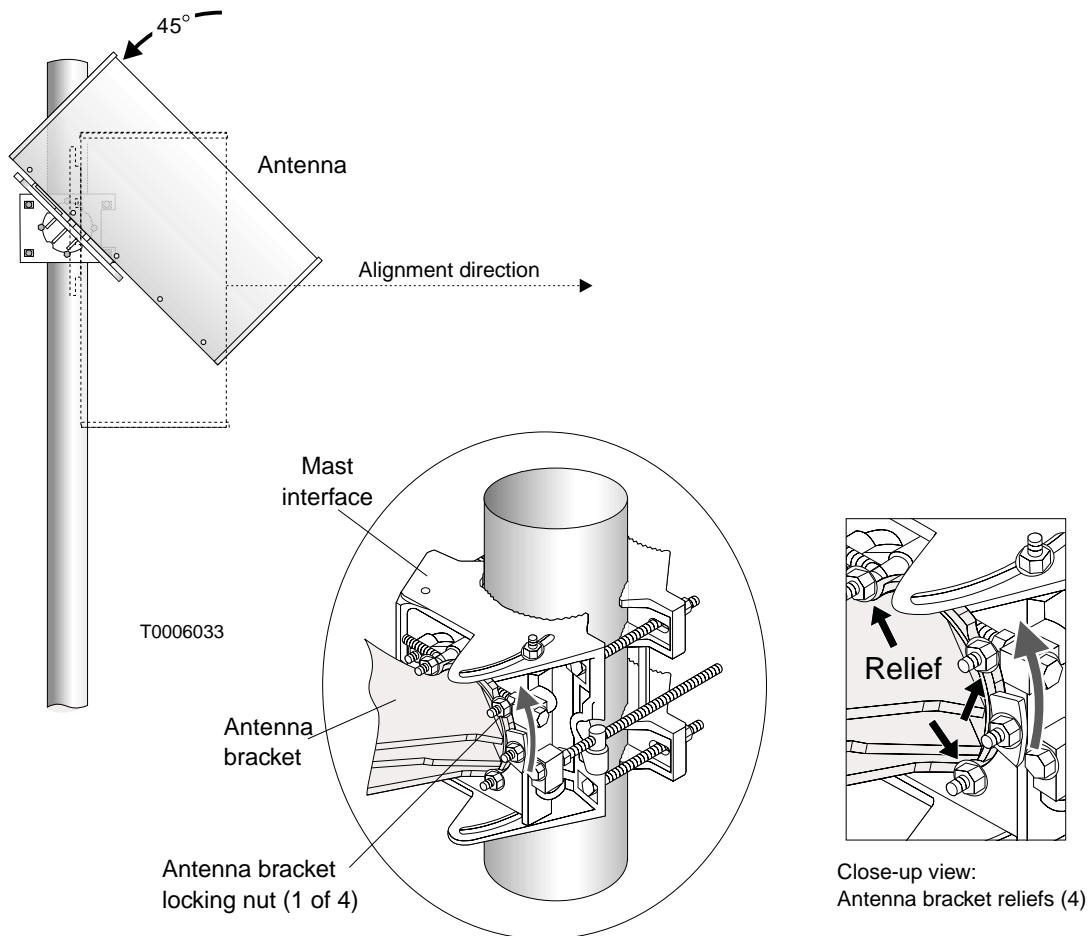
*Some antenna models may be smaller than the antenna shown here.*

**Figure 4-10** The antenna bracket can be oriented to mount to the antenna mount on the left or right.

## Attaching the antenna

Attach the antenna to the mount as follows:

1. With the antenna radome facing in the direction of the assigned HT sector, position the round, flat surface of the antenna bracket approximately 1 inch (2.5 centimeters) from the mast interface.
2. Rotate the antenna approximately  $45^\circ$  away from the HT alignment direction (assigned sector) until the antenna bracket reliefs (curved indentations) are aligned with the four nuts on the mast interface, as shown in figure 4-11.

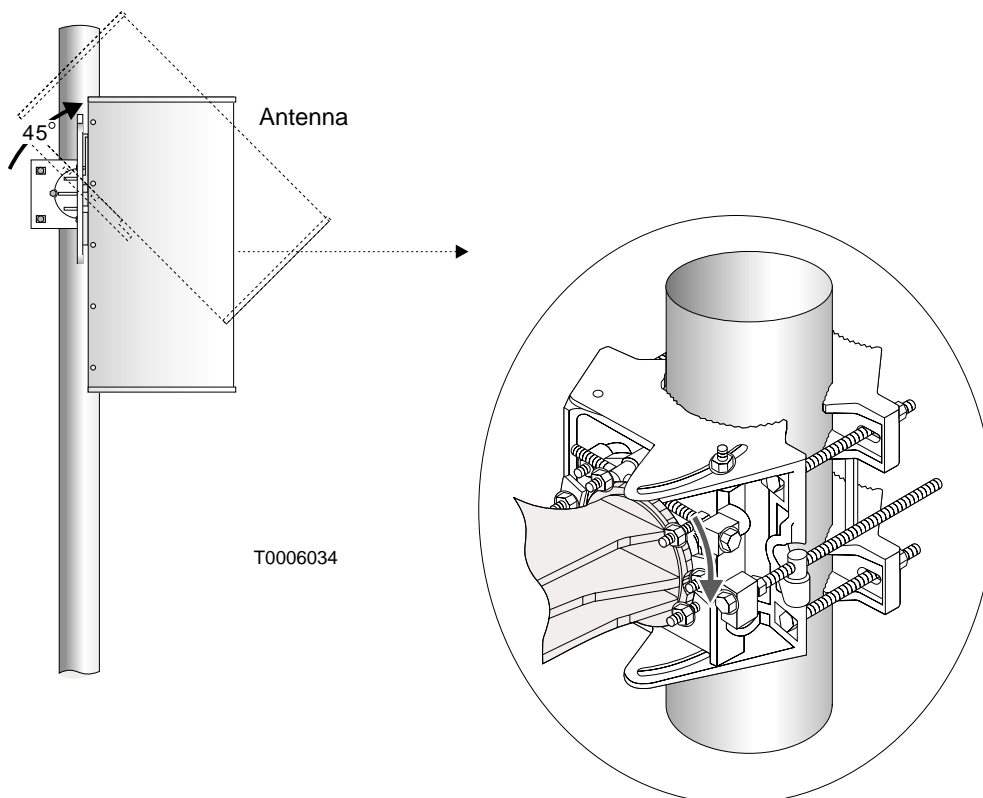


**Figure 4-11** Rotating the antenna so the antenna bracket can be placed against the mast interface

3. Press the antenna against the mast interface.

4. Rotate the antenna approximately  $45^\circ$  toward the HT alignment direction (sector), to the upright position, as shown in figure 4-12—then **finger tighten** the antenna bracket locking nuts so the antenna is snug and without excess movement.

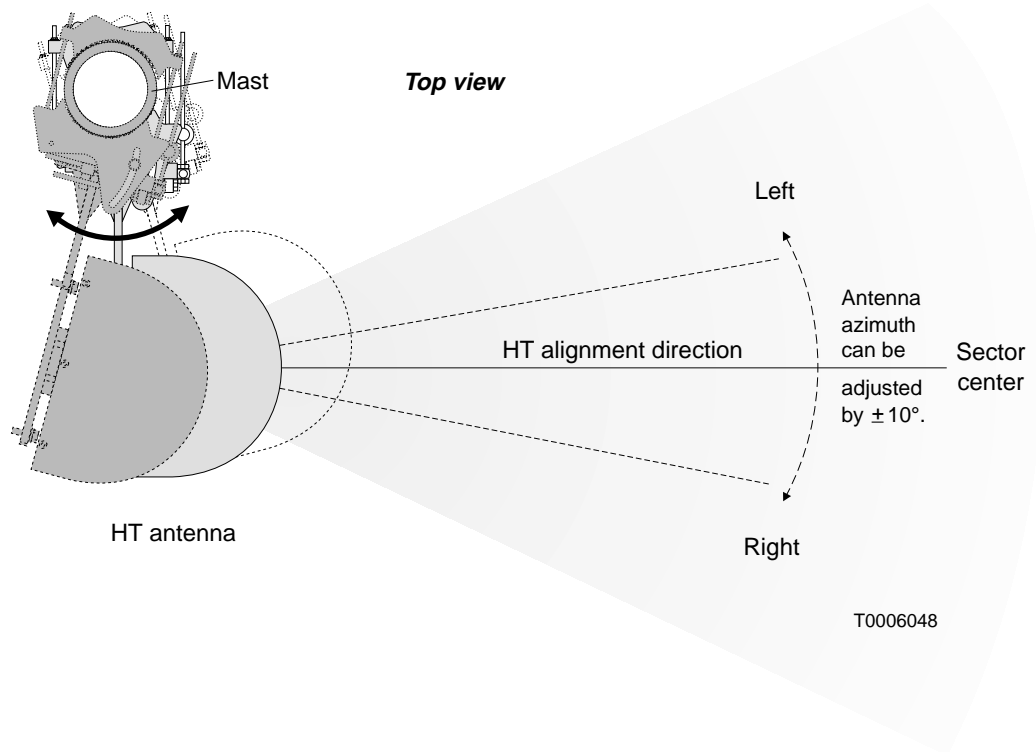
The antenna is now “captured” by the antenna mount. However, because the antenna bracket nuts are not fully tightened, you can rotate the antenna to adjust its elevation.



**Figure 4-12** Rotating the antenna to the upright installation position

## Adjusting the antenna azimuth

To adjust the antenna azimuth (horizontal pointing direction), you move the antenna to the left or right, as illustrated in figure 4-13, until it is pointed in the desired direction (HT alignment direction).



**Figure 4-13 Antenna azimuth adjustment (to right or left)**

Adjust the antenna azimuth as follows:

1. Rotate the antenna mount (and antenna) around the mast to the HT alignment direction.

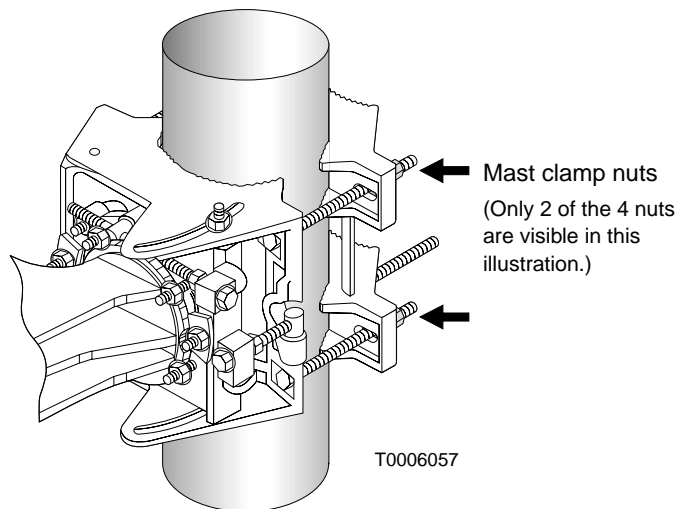
To determine the HT alignment direction with respect to your location on the roof, use the sector map you created (section 4.3) and a compass and/or protractor. Landmarks may also help.

2. When the azimuth is properly adjusted, use a torque wrench with a deep socket to tighten the four mast clamp nuts to 16 foot-pounds torque (21.7 Newton-meters). See figure 4-14. Tighten each bolt a little at a time, moving from bolt to bolt in an X pattern.



**CAUTION**

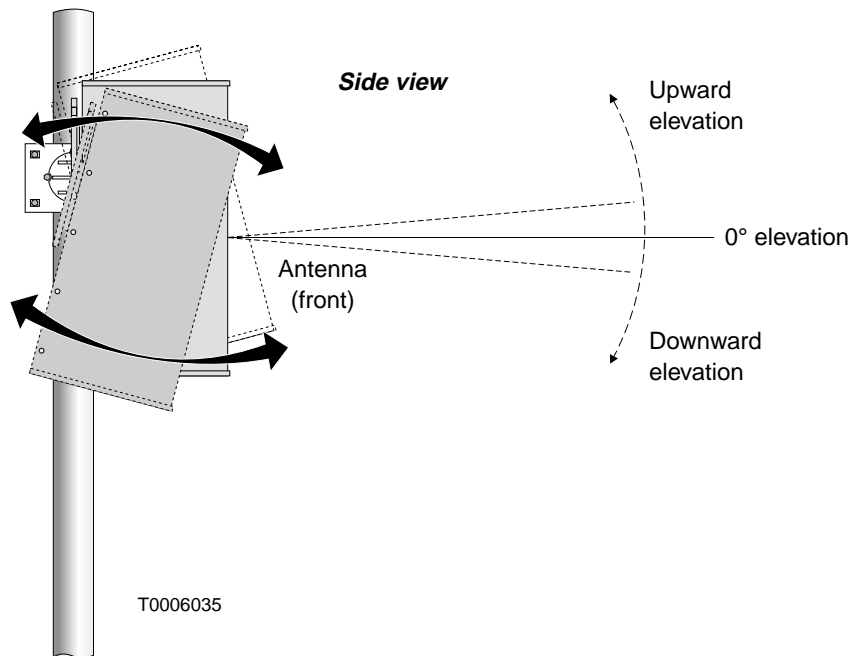
Correct torque is *essential* for successful installation and adjustment. Tighten nuts to the exact torque stated. Incorrect torque may result in damage to equipment.



**Figure 4-14 Mast clamp nuts**

## Adjusting the antenna elevation

To adjust the antenna elevation (upward or downward pointing direction), you rotate the antenna upward or downward, as illustrated in figure 4-15, until the elevation is set as desired.



**Figure 4-15 Antenna elevation adjustment (upward or downward adjustment)**

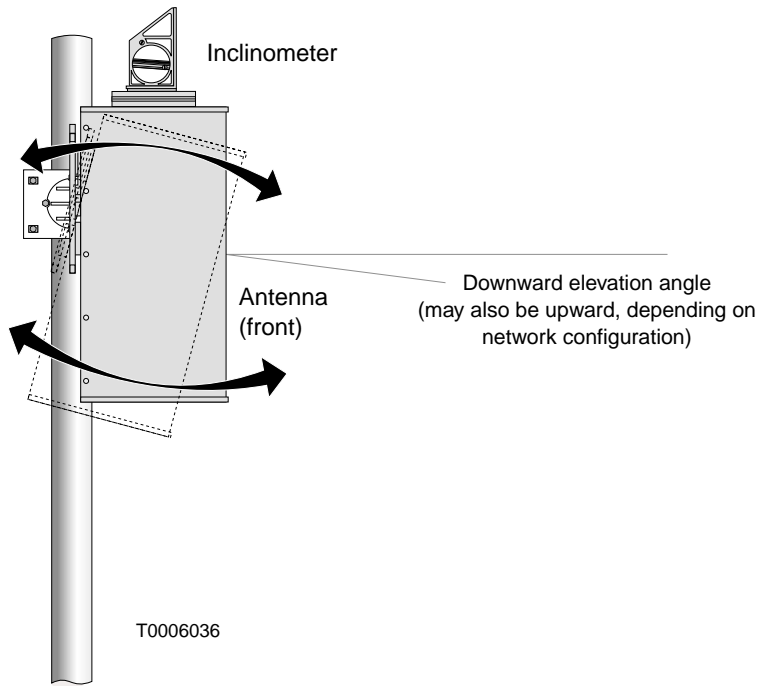
Adjust the antenna to the elevation angle specified in the configuration document as follows:

1. Rotate the antenna until its elevation angle (angle from horizontal) is approximately the same as the specified elevation angle (typically 0° or near 0°).

If the antenna does not rotate freely, loosen each of the antenna bracket nuts *slightly*.

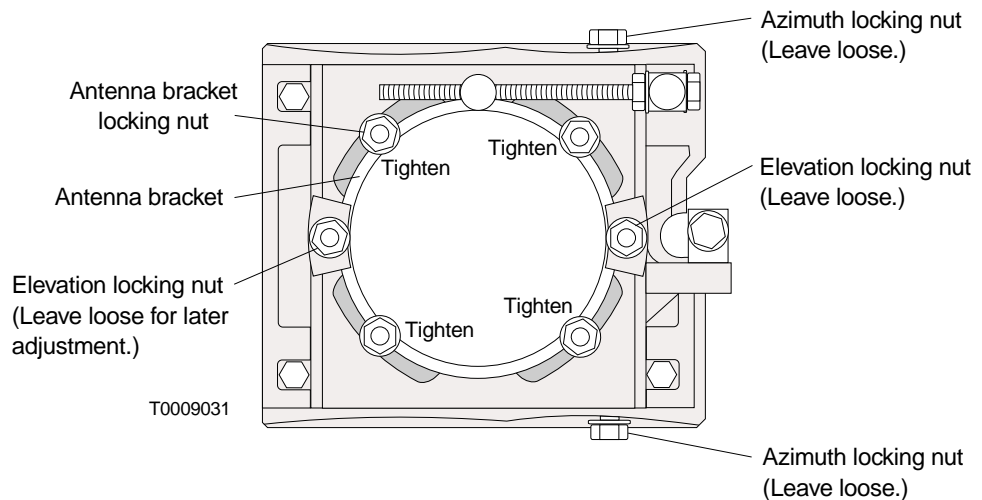


- Place an inclinometer on the top surface of the antenna, as shown in figure 4-16.



**Figure 4-16 Inclinometer on top of the antenna**

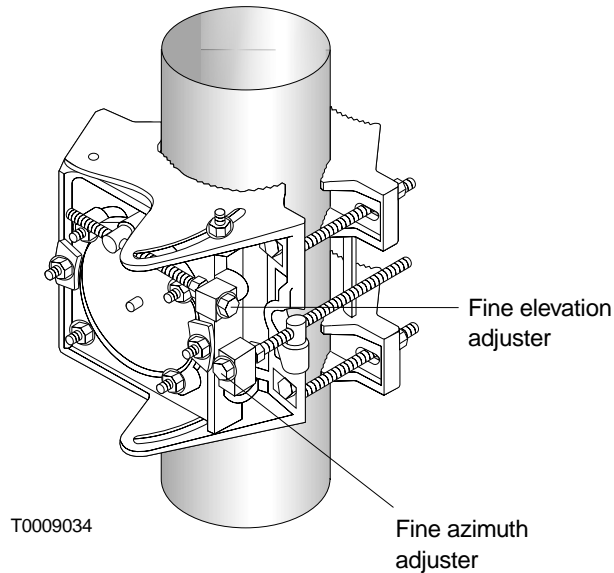
- Adjust the antenna as necessary to obtain the correct elevation angle, as indicated by the inclinometer.
- When the elevation is properly adjusted, tighten the four antenna bracket nuts to 16 foot-pounds torque (21.7 Newton-meters). See figure 4-17.**



**Figure 4-17 Antenna bracket locking nuts (and other nuts)**

## Making fine adjustments

At this point, the mount is tightened to the mast and the antenna is tightened to the mount. If necessary, you can fine-adjust the azimuth and elevation using the built-in adjusters shown in figure 4-18.



**Figure 4-18** Fine azimuth adjuster and fine elevation adjuster

### Azimuth

1. Use a compass or protractor to determine if the antenna azimuth needs to be fine-adjusted.  
**Note:** Accurate azimuth adjustment is especially important for the 22.5° HT antenna. (Sectors are smaller and must be set up precisely to achieve correct coverage.)
2. *If azimuth adjustment is necessary*, use a wrench to slowly rotate the fine azimuth adjuster (shown in figure 4-18) until the azimuth is set correctly.

### Elevation

1. Use the inclinometer to determine if the antenna elevation needs to be fine-adjusted.
2. *If elevation adjustment is necessary*, use a wrench to slowly rotate the fine elevation adjuster (shown in figure 4-18) until the elevation is set correctly.

### Final tightening

1. **When both azimuth and elevation are adjusted correctly, tighten the azimuth and elevation locking nuts (figure 4-17) to 16 foot-pounds (21.7 Newton-meters) torque.**

At this point, antenna installation is complete, and the antenna is aligned. Section 4.10 explains how to attach the transceiver to the antenna.

## Attaching the transceiver to the antenna

Follow these steps to attach the transceiver to the antenna:

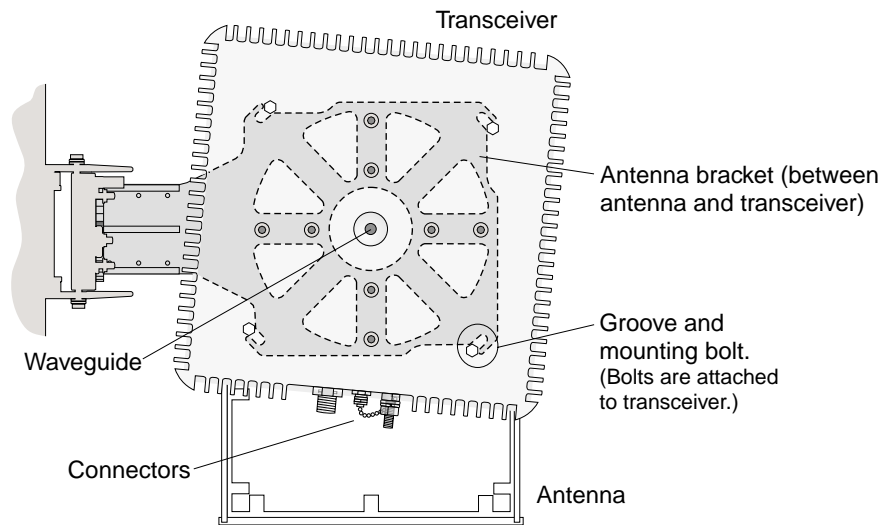
1. Remove the plastic plug from the antenna waveguide and the plastic cap from the transceiver coupling.



### CAUTION

Always keep the waveguide and coupling plugs in place when the transceiver is detached from the antenna, to prevent contamination.

2. Position the transceiver so the three connectors point downward and its four mounting bolts are aligned with the four grooves on the antenna bracket, as shown in figure 4-19.

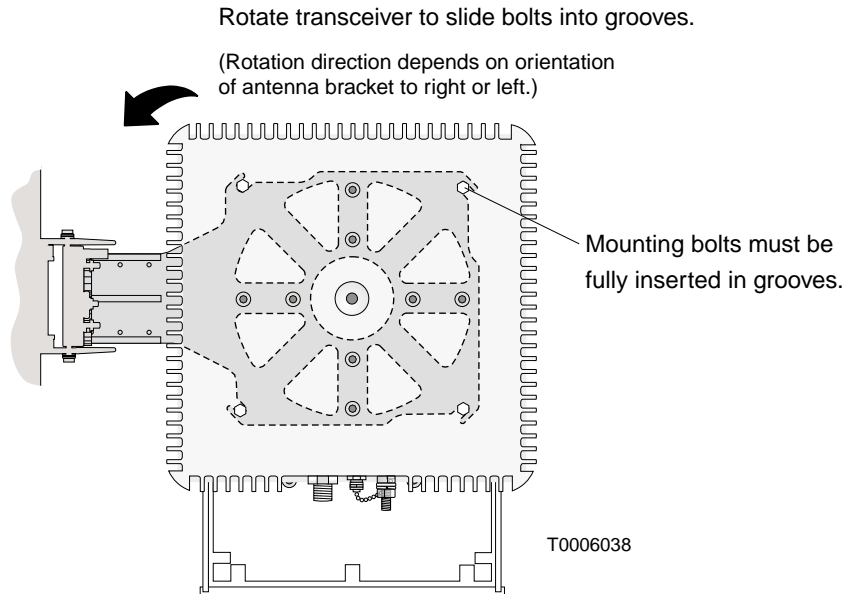


T0006037

*Some antenna models may be smaller than the antenna shown here.*

**Figure 4-19** Aligning the transceiver mounting bolts

3. Rotate the transceiver, making sure the transceiver's mounting bolts slide into the grooves in the antenna bracket. (The direction of rotation depends on the orientation of the antenna bracket—to the right or left.) If the mounting bolts will not slide into the grooves, loosen the bolts. See figure 4-20.



**Figure 4-20 Transceiver (installed)**

4. Tighten the mounting bolts.
5. After tightening the transceiver, use the sector map, protractor, and inclinometer to make sure the azimuth and elevation adjustments are correct.

## Grounding the ODU

Grounding the ODU requires several connections, as shown in figure 4-21. In making the ground connections, *follow these practices*:

- For all ODU ground connections, use compression connectors (such as compression lugs or compression clamps).
- For all threaded ground connections, use a flat washer and lock washer (with the lock washer next to the nut).

Ground the ODU as follows:

1. Connect one end of the ground cable (No. 6 AWG or greater, green) to the ODU ground connector, which is shown in figure 4-21.
2. Connect the ground cable to a bolted joint on the mast mount.

**Important:** For this connection, strip the cable but **do not cut it**. See figure 4-21. The cable continues from the bolted joint to the ground point.

3. Connect the ground cable to a suitable ground point on the rooftop.

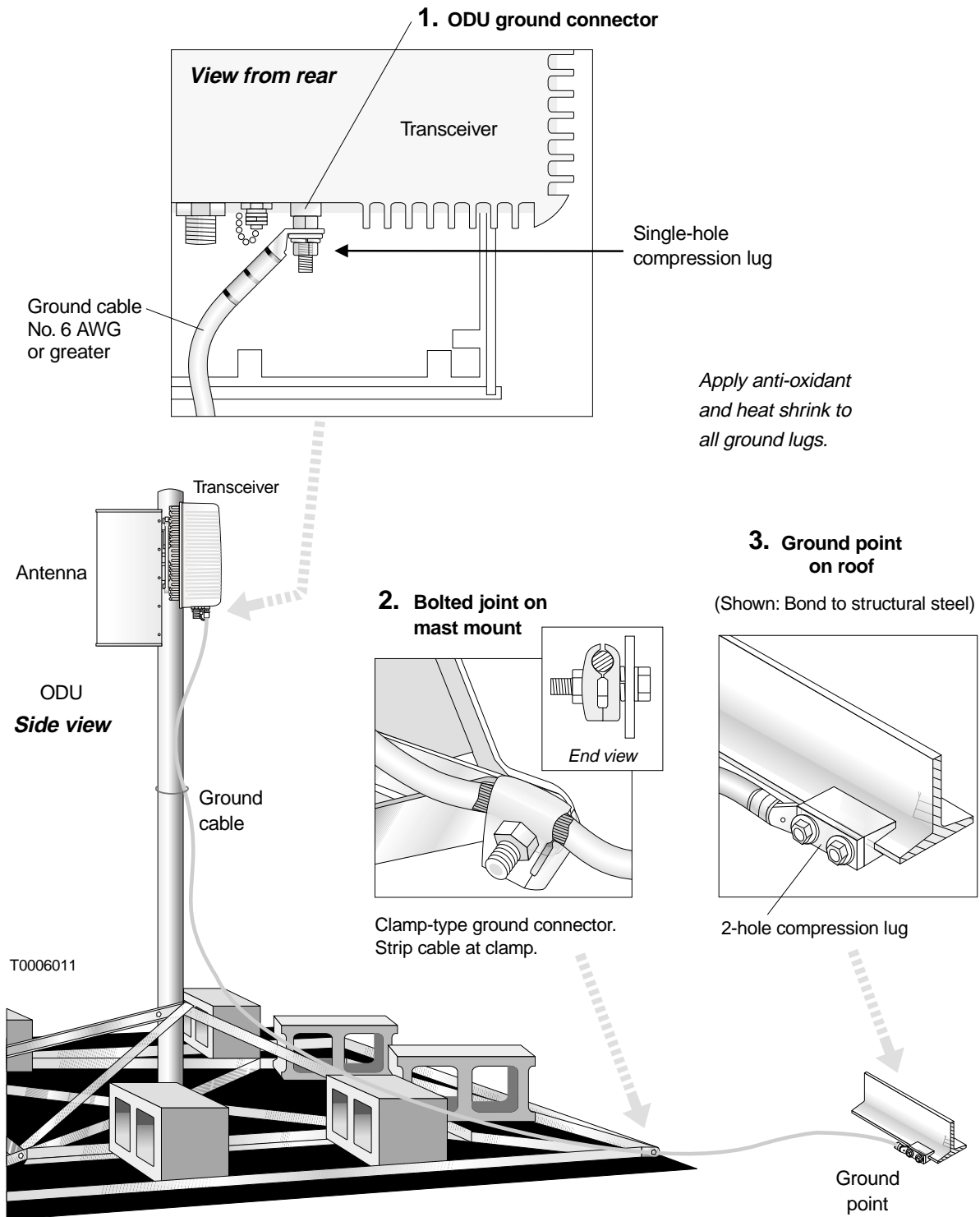
The best ground point for the ODU is an earth-referenced roof ring conductor that follows the perimeter of the building, constructed according to the requirements of NFPA 780 or a similar regulatory code. However, such a conductor is not always present. Other alternatives are acceptable, as long as they comply with the grounding requirements detailed in the *Hub and Remote Terminal Site Preparation Guide*.

Building steel can also be used as a ground point. **However, before using building steel, verify that the steel structure is electrically continuous throughout the entire building and that it is properly connected to earth ground.** For detailed grounding requirements, see the *Hub and Remote Terminal Site Preparation Guide*.

4. Apply anti-oxidant (HNS 9008224-0002) to each ground lug (points 1, 2, and 3 in figure 4-21).
5. Apply 1/2-inch (13-millimeter) heat shrink tubing (HNS 9007488-0005) to each ground lug after the connection is complete.

**Important:** You must slip the heat shrink onto the cable *before* you make the connections.

**Note:** A resistance of less than 5 ohms is desirable from the ODU to earth, including the earth field.



**Figure 4-21 ODU grounding connections**

### Lightning protection

Lightning protection is provided by grounding the ODU as stated above and installing a lightning arrester where the IFL cable enters the roof (as explained in section 5.7). **The ODU ground and IFL lightning arrester must both be bonded to the same ground (reference) point.**

## Chapter 5

# Installing IFL cables

---

This chapter includes:

- IFL cable specifications – page 5–2
- Overview: IFL plan – page 5–3
- Determining the IFL cable route – page 5–4
- Penetrating the roof – page 5–5
- Installing the penetration sleeve – page 5–6
- Installing the IFL cable inside the building – page 5–7
- Installing the hub lightning arrestor – page 5–8
- Installing the IFL cable on the roof – page 5–13
- Testing the IFL cable – page 5–15
- Connecting the IFL cable to the ODU – page 5–15

*Appendix C covers IFL cable termination in detail.*



### **DANGER**

**Do not work on a ladder or roof without first reading the safety warnings on page x of this manual. Failure to observe these warnings could result in personal injury or death.**

**Note:** The lightning arrestor and penetration sleeves referred to and illustrated in these instructions are not specific parts available from HNS. They are presented to illustrate a typical solution for providing grounded lightning arrestor protection for one or more IFL cables. Other solutions are acceptable as long as they comply with the IFL grounding requirements specified in the *Hub and Remote Terminal Site Preparation Guide*.

---

## IFL cable specifications

The intrafacility (IFL) cable specified for AIReach Broadband installations is a Type 3 coaxial cable, HNS 1010812–0001 (1,000–foot / 305–meter spool). This cable is non plenum, CMG UL/C (UL) approved. An acceptable alternative is LMR–400 plenum cable (available from Times Microwave Systems, Wallingford, CT). For additional specifications, see the *Hub and Remote Terminal Site Preparation Guide*.

The following Underwriters Laboratories (UL) requirement applies to the IFL cable:

**The IFL cable must be installed in a metal conduit and grounded according to NEC article 800–40. If the IFL cable will *not* be installed in a metal conduit, the cable must be a plenum cable, UL/C(UL) approved, with a CMR rating (or higher).**

For specific grounding instructions, see *Grounding the lightning arrester* in section 5.7. Refer also to the grounding guidelines included in the *Hub and Remote Terminal Site Preparation Guide*.

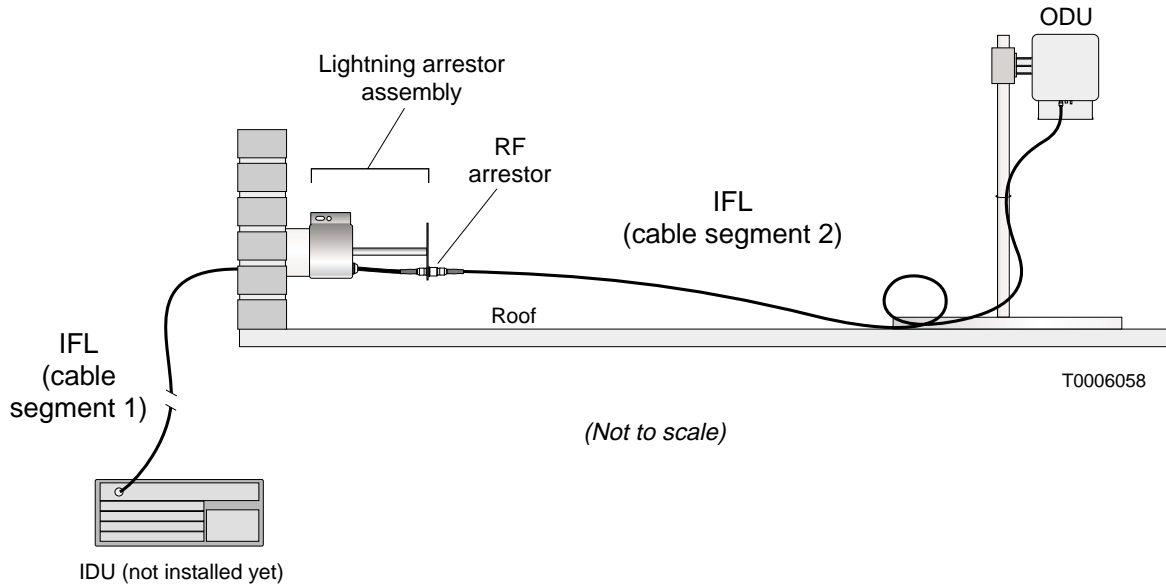


**Overview: IFL plan**

Figure 5-1 shows the IFL and lightning arrester. **A lightning arrester is required on the roof at the IFL building penetration point.**

Figure 5-1 shows how the IFL cable is installed in two segments to accommodate the lightning arrester:

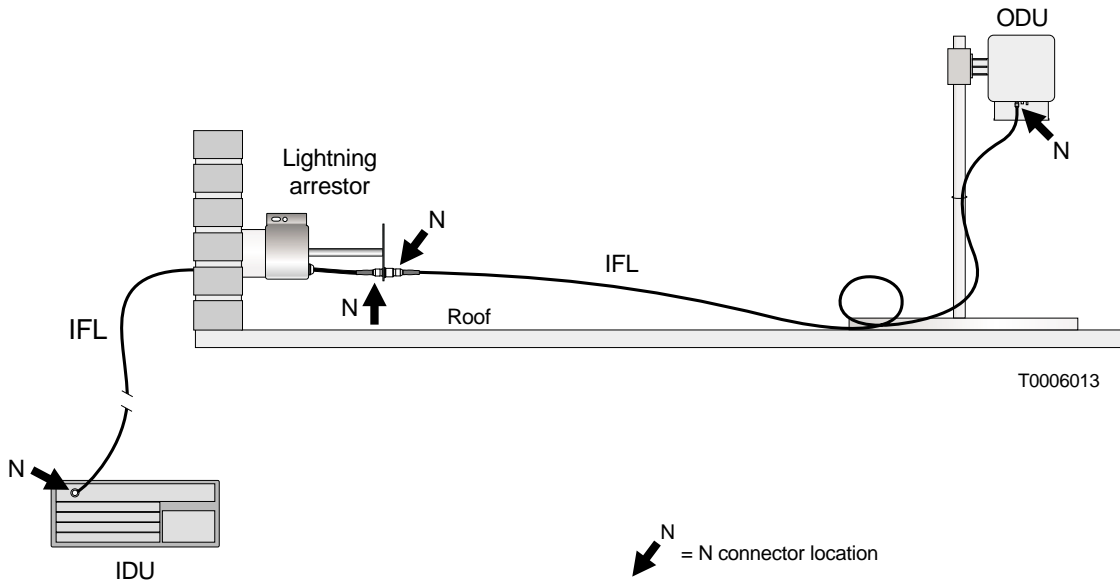
- One segment from the IDU to the rooftop lightning arrester
- One segment from the lightning arrester to the ODU



**Figure 5-1 IFL plan**

**IFL connections**

Because the IFL cable is installed in two segments, it is cut and terminated (with an N-type connector) in four locations, as shown in figure 5-2.



**Figure 5-2 Four locations where N connectors are installed**

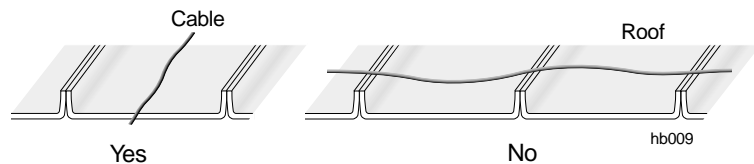
Detailed instructions for installing the IFL and lightning arrestor are included in the following sections.

## 5.3

### Determining the IFL cable route

Determine the IFL cable route, from IDU to ODU. Consider the guidelines below. Every building and rooftop is unique; for this reason, some of these guidelines may not apply to your installation:

- The most important considerations are the ODU and IDU locations and the building entry point. The entry point should be as close as possible to the ODU. Refer to the HT rooftop drawings. See also page 3–3.
- The maximum IFL cable length is 1000 feet (305 meters).
- Where possible, use existing conduit.
- You must use a pull box to facilitate pulling cables through conduits if routing cable through bends totaling more than 360°.
- If existing conduits can not be used and the cable will be exposed, refer to building codes to determine proper cable insulation type. For example, plenum rated cable must be used if cable will be run above suspended ceilings.
- **If you are installing the IFL cable(s) inside a conduit that contains power cables, you must use plenum-rated cable.**
- Look for cable routes that will be easily accessible, such as stacked telco closets etc.
- Older buildings may not have stacked telco closets. You may have to route the cable back and forth, from one side of the building to the other.
- Never run the IFL cable across corrugated roofing. Run the cable in the corrugation trough:



## 5.4

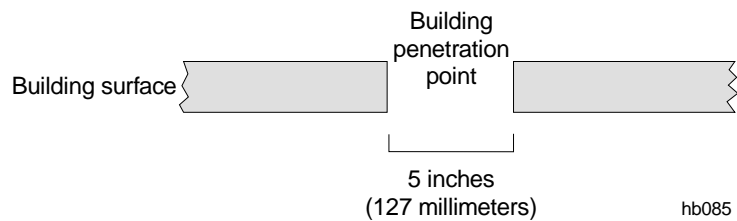
### Penetrating the roof

Follow the steps below to drill a hole for the IFL cable *only when there is not an existing entry you can use.*

1. Go to the roof.
2. Determine where the IFL cable will penetrate the roof.  
Refer to the HT rooftop drawings.

Before you drill, consider these guidelines:

- **Important: Do not penetrate any part of the building structure without first making sure you have the explicit permission of the customer and building owner.**
  - Horizontal penetration is preferable to vertical penetration. (A horizontal hole is less likely to leak.)
  - Take care not to destroy cabling or wiring under the roof or inside the wall.
  - Round penetration holes are preferred over square holes. (They are easier to make and seal.)
3. Drill a 5-inch (127-millimeter) diameter hole at the building penetration point.



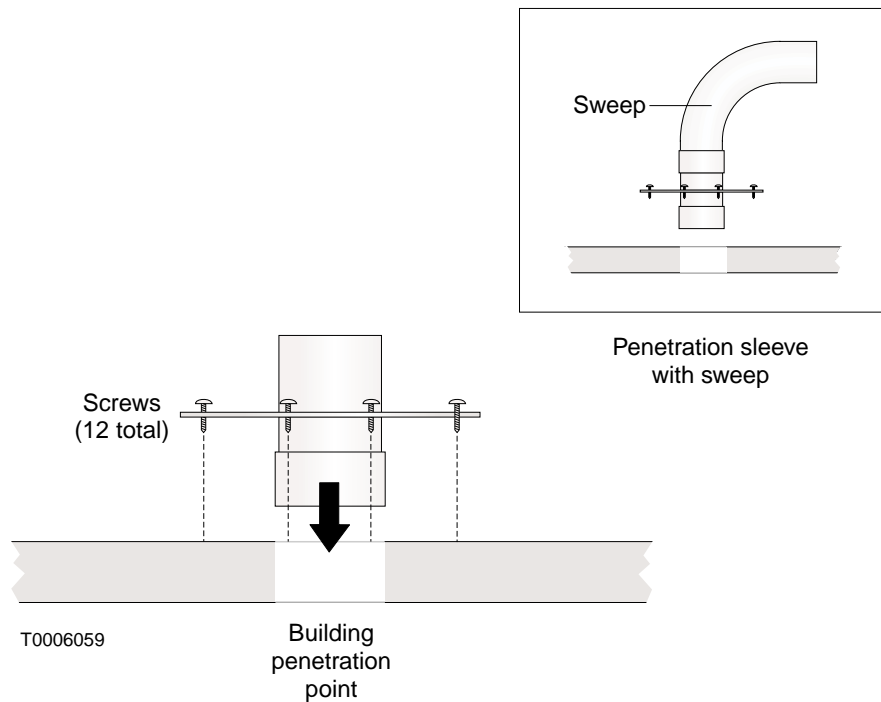
## Installing the penetration sleeve

The IFL cable must be routed through a penetration sleeve before it is connected to the lightning arrester. The lightning arrester is attached to the penetration sleeve after cable installation.

1. Use twelve screws to attach the hub penetration sleeve (sleeve and coupling) to the building surface at the building penetration point. See figure 5-3.

The type of screw used depends on the roof thickness and surface composition. The screws *must* hold the sleeve securely.

**Note:** If space is limited, use a 90° sweep, as illustrated in in figure 5-3.



**Figure 5-3** Installing the hub penetration sleeve

2. Weatherproof the penetration sleeve by applying silicone caulk or other weatherproofing material to the bolt hole areas and the surface of the sleeve plate.

**Note:** Silicone caulk may not be suitable for certain types of roofs.

## Installing the IFL cable inside the building

You install the IFL cable in two segments, as shown in figure 5-1 (on page 5-3). To install the first cable segment—from the IDU chassis location to the lightning arrester—follow the instructions and guidelines below. Because every building has unique features, it is not possible to give exact instructions.

1. Measure the cable run length from the IDU chassis location to the lightning arrester location (IFL building entry point). Allow for routing around obstacles and a service loop (excess cable, in case there is any reason to later cut and re-terminate the cable).
2. Run the cable from the IDU chassis location, through an existing conduit if possible, through the hub penetration sleeve (figure 5-3), to the lightning arrester location. Use a stand so the cable spool spins freely as it is pulled. Leave a service loop.



### CAUTION

Avoid making sharp bends in the IFL cable. The minimum bend radius for IFL cable is 2 inches (51 millimeters). Sharper bends may cause permanent damage to the cable.

3. Cut the cable at the IDU chassis location and at the lightning arrester.

**Important:** Cut the cable 2 feet (0.6 meters) beyond the lightning arrester location (building penetration point).

4. Terminate the cable end at the IDU chassis location with an N-type connector. For detailed instructions for connecting an N connector, see appendix C.

**Important:** Sound IFL cable connections are critical for proper operation of the AIReach Broadband system.

Therefore, be very careful in terminating the cable. Refer to the detailed instructions in appendix C if necessary.

**Attach N connectors *after* you route and install the cable, not before.**

**Note:** The IFL cable installation is completed in section 5.8.

## Installing the hub lightning arrester

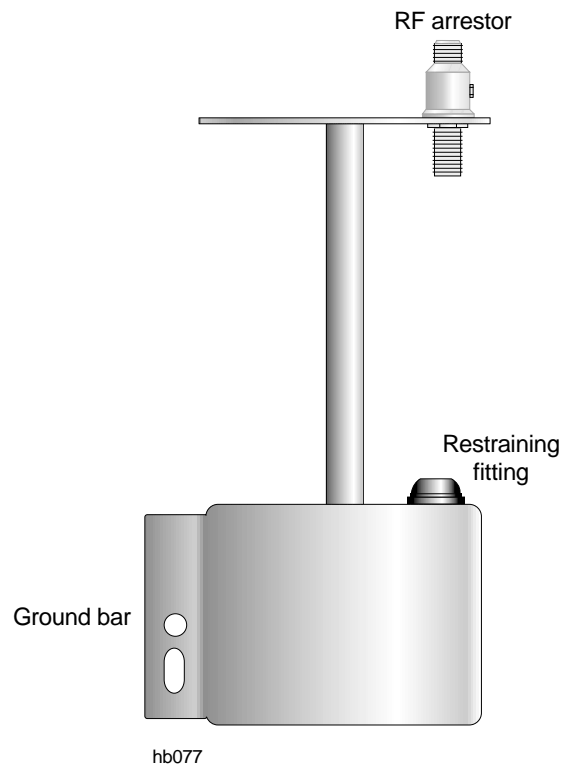
All AIReach Broadband IFL cables must connect to a grounded lightning arrester at the building penetration point, as shown in figure 5-1 (page 5-3) and explained in this section.



### WARNING

To help avoid death, injury, or damage from a lightning strike, you *must* install a lightning arrester where the IFL enters the building.

Figure 5-4 identifies the components of a typical hub lightning arrester. The design illustrated here (see also figure 5-5) can accommodate up to eight IFL cables for up to eight HTs.



**Figure 5-4** Typical hub lightning arrester

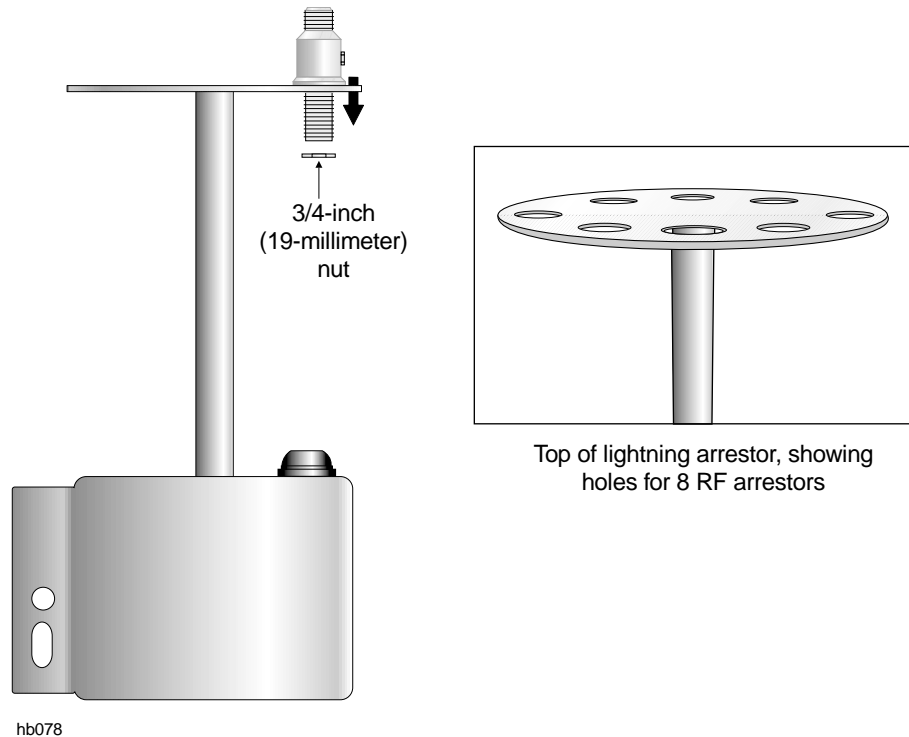
Go to the roof to install the lightning arrester.

## Connecting the IFL cable to the RF arrester

Follow these steps to route the IFL cable through the lightning arrester and connect the cable to the RF arrester:

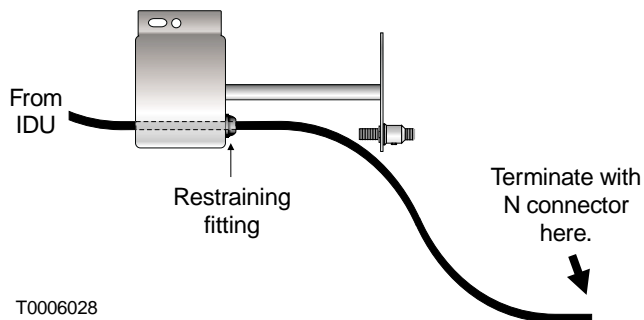
1. Attach an RF arrester to the arrester body with a 3/4-inch (19-millimeter) nut. See figure 5-5.

The illustrated hub lightning arrester design can accommodate up to eight RF arresters, to provide protection for up to eight IFL cables.



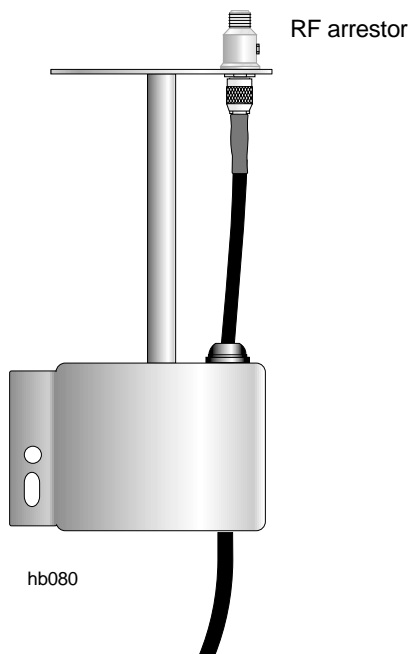
**Figure 5-5** Attaching the RF arrester to the arrester body

2. Route the cable from the IDU chassis location through the base of the lightning arrestor and the restraining fitting, as shown in figure 5-6.



**Figure 5-6 Routing IFL cable**

3. Terminate the end of the IFL cable with an N connector. For detailed instructions for connecting an N connector, see appendix C.
4. Connect the cable to the RF arrester, as shown in figure 5-7.
5. Working from inside the arrester body, use a wrench to tighten the restraining fitting.
6. If you are installing additional IFL cables, repeat steps 1 through 5



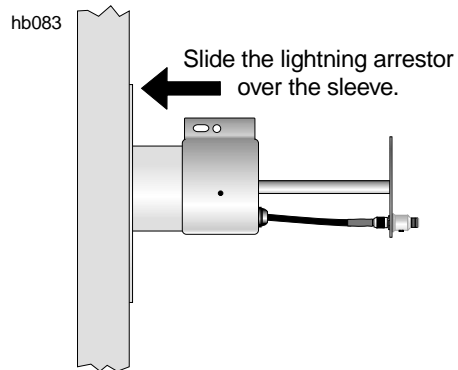
**Figure 5-7 Connecting the IFL cable to the RF arrester**



## Attaching the arrester to the penetration sleeve

Attach the lightning arrester to the penetration sleeve:

1. Slide the lightning arrester over the sleeve, as shown in figure 5-8.
2. Fasten the lightning arrester to the sleeve with a screw.

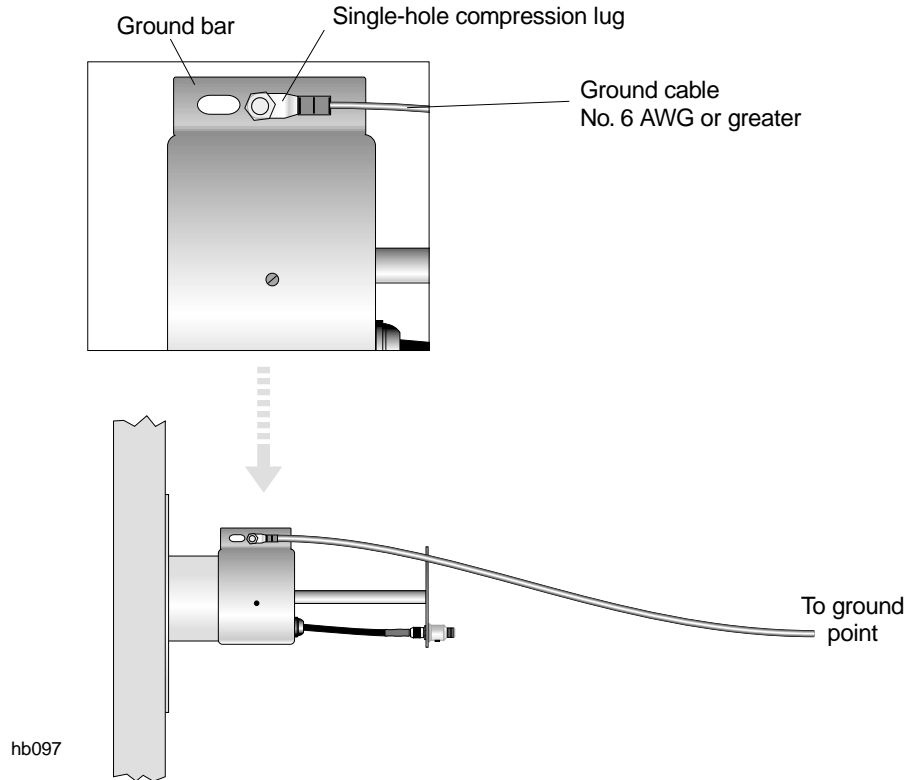


**Figure 5-8 Attaching the lightning arrester to the sleeve**

## Grounding the lightning arrester

Follow these steps to ground the lightning arrester:

1. Connect one end of the ground cable (No. 6 AWG or greater, green) to the lightning arrester ground bar, as shown in figure 5-9.



**Figure 5-9** Hub lightning arrester grounding connections

2. Route the ground cable to the ground point.

When routing the ground cable, you must:

- **Secure the ground cable at 5-foot (1.5-meter) intervals.**
- **Keep the ground cable at least 3 feet (0.9 meters) away from non-grounded metal objects.**
- **Make sure all bends in the cable have a sweeping radius of more than 8 inches (20.3 centimeters).**

3. Connect the hub lightning arrester to the same ground (reference) point as the ODU ground. See section 4.11.
4. Apply anti-oxidant (HNS 9008224-0002) to each ground lug.
5. Apply 1/2-inch (13-millimeter) heat shrink tubing (HNS 9007488-0005) to each ground lug after the connection is complete.

**Important:** You must slip the heat shrink onto the cable *before* you make the connections.

---

## Installing the IFL cable on the roof

To install the second IFL cable segment—from the lightning arrester to the ODU—follow the instructions and guidelines below. Because every rooftop has unique features, it is not possible to give exact instructions.

### Connecting to the lightning arrester

Connect the IFL to the lightning arrester as follows:

1. Measure the cable run length from the lightning arrester to the ODU. Allow for routing around obstacles and a service loop (excess cable, in case there is any reason to later cut and re-terminate the cable).
2. Run the cable from the lightning arrester to the ODU. Leave a service loop.



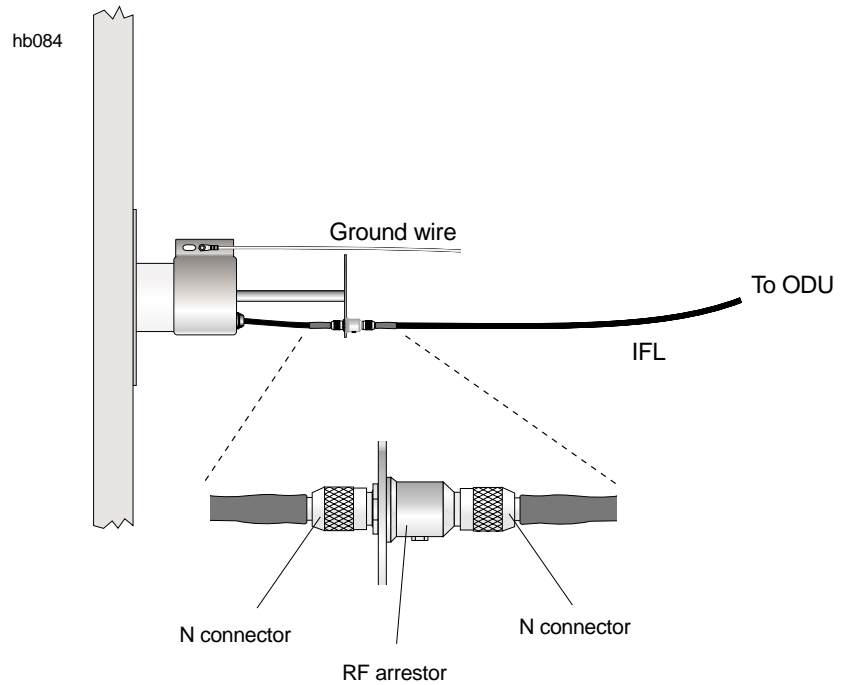
#### CAUTION

**Avoid making sharp bends in the IFL cable. The minimum bend radius for IFL cable is 2 inches (51 millimeters). Sharper bends may cause permanent damage to the cable.**

---

3. Cut the cable at the lightning arrester and at the ODU.
4. Terminate both ends of the cable segment with N connectors. For detailed instructions for connecting N connectors, see appendix C.

5. Connect the cable to the RF arrester, as shown in figure 5-10.



**Figure 5-10** Connecting the IFL to the RF arrester

**Note:** The IFL cable is connected to the IDU after the CCM and SSIs are installed (chapter 6).

**Do not apply permanent weatherproofing until the HT has been tested and commissioned. If the weather is wet or windy, a temporary tape seal is recommended. Weatherproofing is covered in section 8.1.**

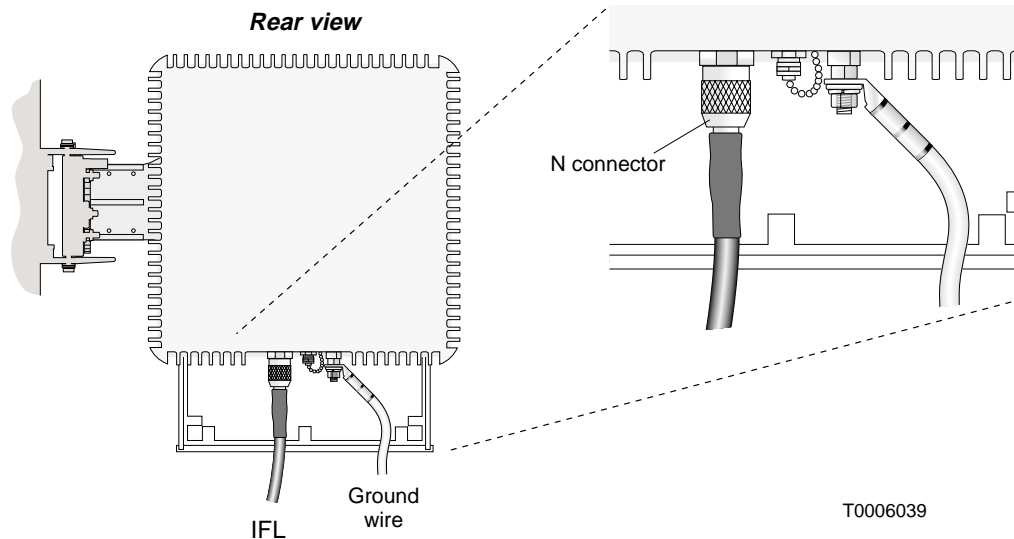
## Testing the IFL cable

Test the IFL cable and connectors as follows:

1. Check each connector: Use a multimeter or continuity tester to check for continuity (a short circuit) *between the center conductor and the connector body (outer shell)*.  
If the meter or tester does not indicate an open (no connection), the connector or cable is defective and must be replaced.
2. Check the connectors and cable:
  - a. Using a small jumper cable, attach a jumper clip to the center conductor of the connector on one end of the cable.
  - b. Attach the other end of the jumper to the connector body, so the center conductor and connector body make electrical contact.
  - c. *At the other end of the cable (at the IDU location)*, use a multimeter to measure the resistance between the center conductor and connector.  
Resistance should be less than 10 ohms. If it is greater than that find and correct the problem.

## Connecting to the ODU

1. Connect the IFL to the ODU as shown in figure 5-11.



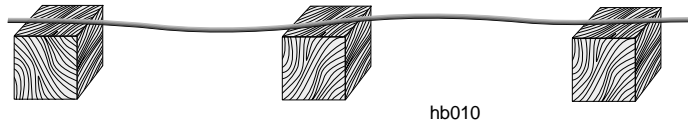
**Figure 5-11 Connecting the IFL to the ODU**

2. Apply electrical tape to the N connector for temporary protection against moisture contamination.  
**Do not apply permanent weatherproofing until the HT has been tested and commissioned. If the weather is wet or windy, a temporary tape seal is recommended. Weatherproofing is covered in section 8.1.**

## Finishing the cable installation

After running the cable, finish the cable installation as follows:

1. Support the cable above the roof surface with a cable trough or wood blocks approximately 4 inches by 4 inches by 4 inches (10 centimeters by 10 centimeters by 10 centimeters):



2. Tie down cable runs on the roof and at the IDU location with tie-wraps.
3. Seal the IFL rooftop entry point with weatherproofing caulk.
4. Label both ends of the IFL cable to identify the cable in an appropriate manner. This is especially important if you are installing multiple IFL cables. (To order IFL labels, request HNS part number 9005328-0055.)

# Installing indoor hub equipment

---

This chapter includes:

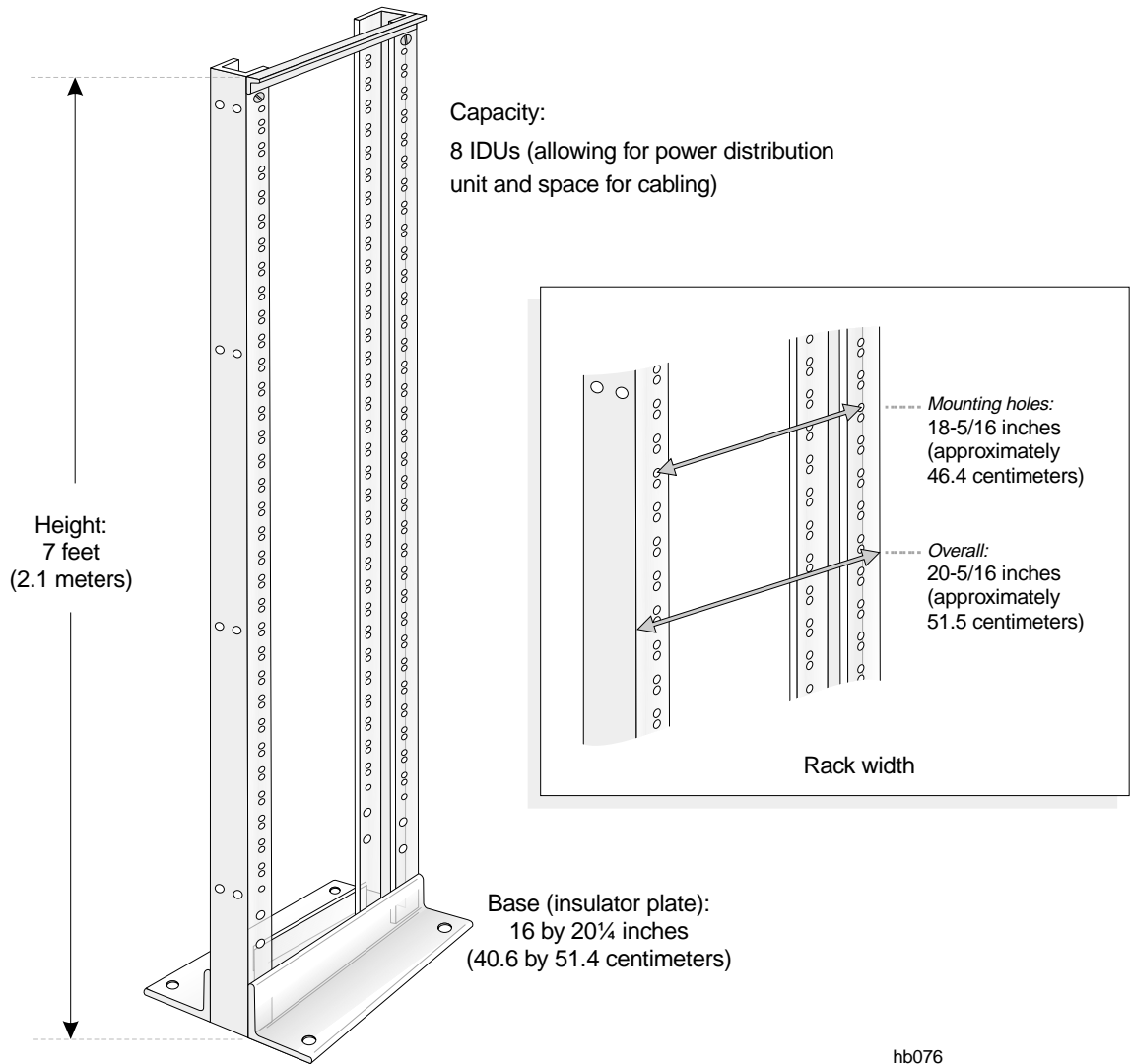
- Installing the hub rack – page 6–2
- Installing indoor units (IDUs) – page 6–7
- Power supplies – page 6–11
- Installing the CCM – page 6–26
- SSIs – page 6–28
- Connecting the IFL to the CCM – page 6–33
- CCM redundancy bus cable – page 6–34
- Front panel LCD operation – page 6–35
- CCM power-on test – page 6–37
- Hub LAN router and LAN hub – page 6–39

*For IDU standards compliance information, see appendix B (page B–3).*

## Installing the hub rack (optional)

The optional hub rack (figure 6-1) provides a location for mounting:

- IDUs (8 maximum)
- A dc power distribution unit
- The hub LAN router



**Figure 6-1** Optional hub rack

Follow these instructions to install the hub rack—if the hub plans call for a rack or racks:

1. Refer to the hub plans and drawings to determine where the rack should be installed.



2. Remove the hub rack assembly from its shipping container.



### WARNING

The optional hub rack weighs approximately 115 pounds (52.2 kilograms) empty. Do not attempt to lift it by yourself. Two people should lift or move the rack, when necessary. Failure to observe this warning could result in personal injury.

3. Place the isolation pad (HNS 1018302-0001) where the rack will be installed, and mark the anchor hole locations on the floor with a pencil.
4. Using a hammer and center punch, mark the center of each mounting hole location.

• *Follow steps 5 through 11 if the floor is concrete:*

*(If the floor is wood, skip to step 12.)*

5. Using a 1-inch carbide-tipped drill bit, drill a hole 5 1/2 inches (14 centimeters) deep in each of the locations you marked in step 4. See figure 6-2.

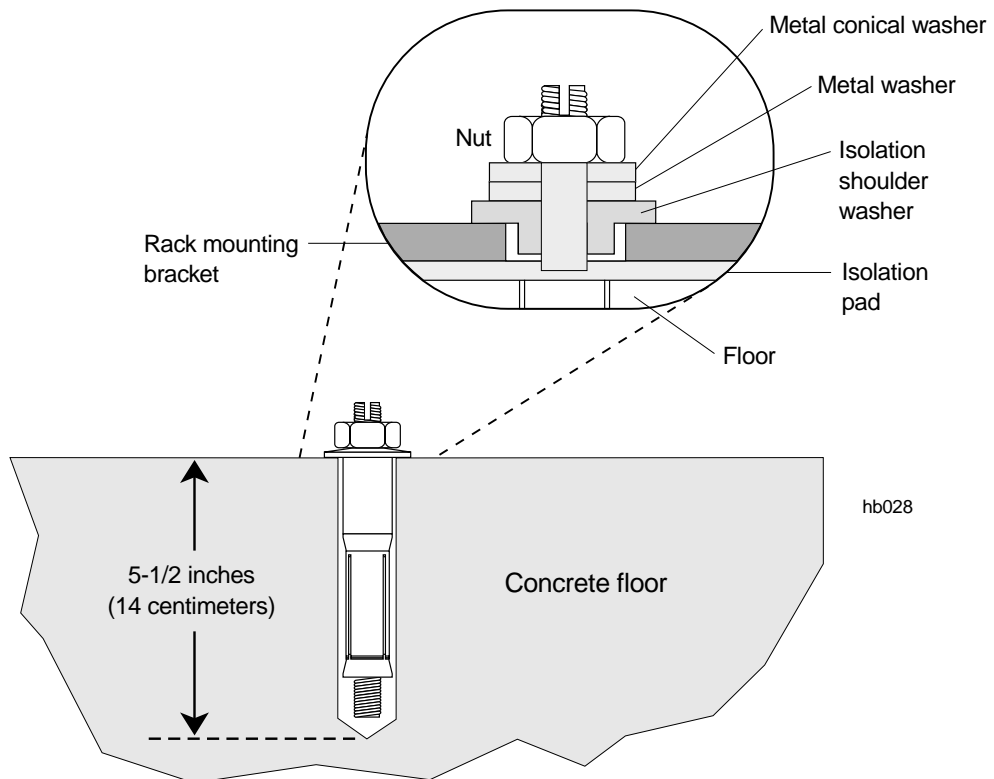


Figure 6-2 Installing safety bolts into a concrete floor

6. Clean out the holes and position the isolation pad and rack mounting bracket over the holes as shown in figure 6-2.
7. Remove the nut and washers from each safety bolt, if used, and place the appropriate washers on the shaft, as shown in figure 6-2. Then drop a safety bolt into the hole.

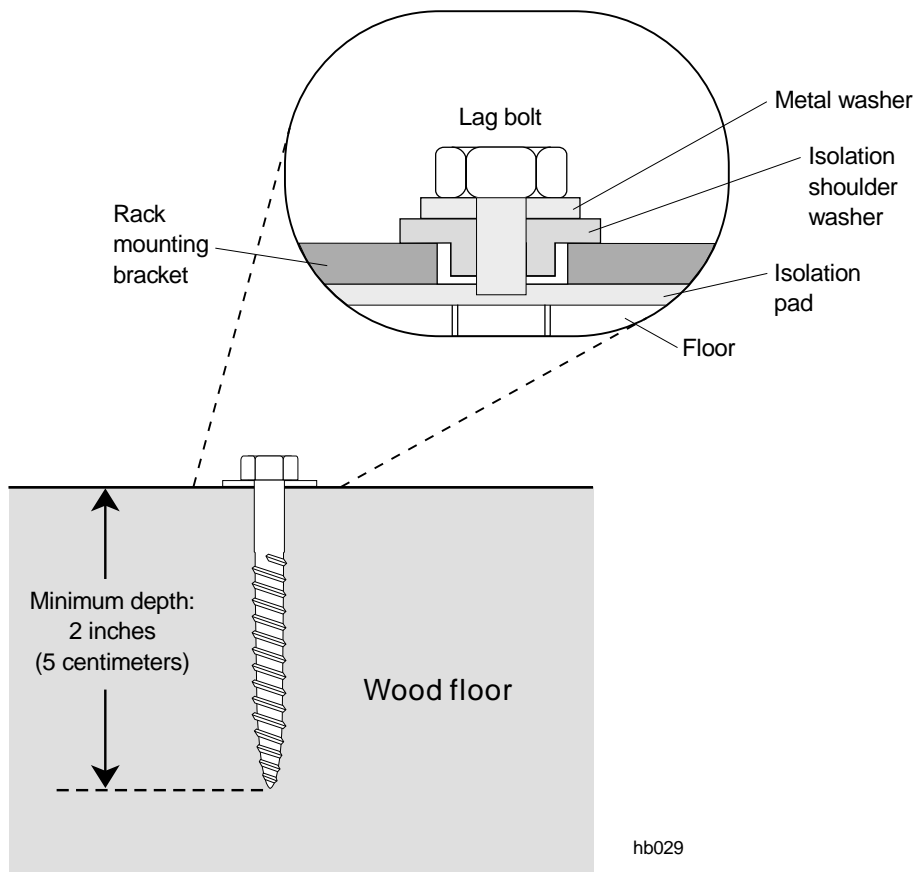


### CAUTION

When installing the isolation shoulder washer, make sure the shoulder seats completely into the metal floor mounting bracket. Isolation may be compromised if this washer is damaged or improperly installed.

---

8. Use a torque wrench to tighten each safety bolt to 15 foot-pounds (20.3 Newton-meters) of torque.  
The slotted sleeve on the safety bolt will be forced against the walls of the hole, anchoring the safety bolt securely.  
**Note:** If you do not have a torque wrench, use a ratchet wrench to tighten the safety bolt until the conical washer (shown in figure 6-2) flattens completely.
  9. Once the anchor is set, loosen the nut and insert a flat-blade screwdriver into the threaded rod slot.
  10. Hold the nut with a 1-1/16-inch open-end wrench while turning the screwdriver clockwise until the top of the rod is even with the top of the nut.
  11. While holding the screwdriver in this position, tighten the nut.  
The threaded rod and the top of the nut will be flush.
- *Follow steps 12 through 15 if the floor is made of wood:*
12. Using a 5/16-inch drill bit, drill a hole at least 2 inches (5 centimeters) deep in each of the locations you marked in step 4.
  13. Clean out the holes and position the isolation pad and rack mounting bracket over the holes, as shown in figure 6-3.



**Figure 6-3** Installing lag bolts into a wood floor

14. Place the washers shown in figure 6-3 onto the lag bolt.



**CAUTION**

When installing the isolation shoulder washer, make sure the shoulder seats completely into the metal floor mounting bracket. Isolation may be compromised if this washer is damaged or improperly installed.

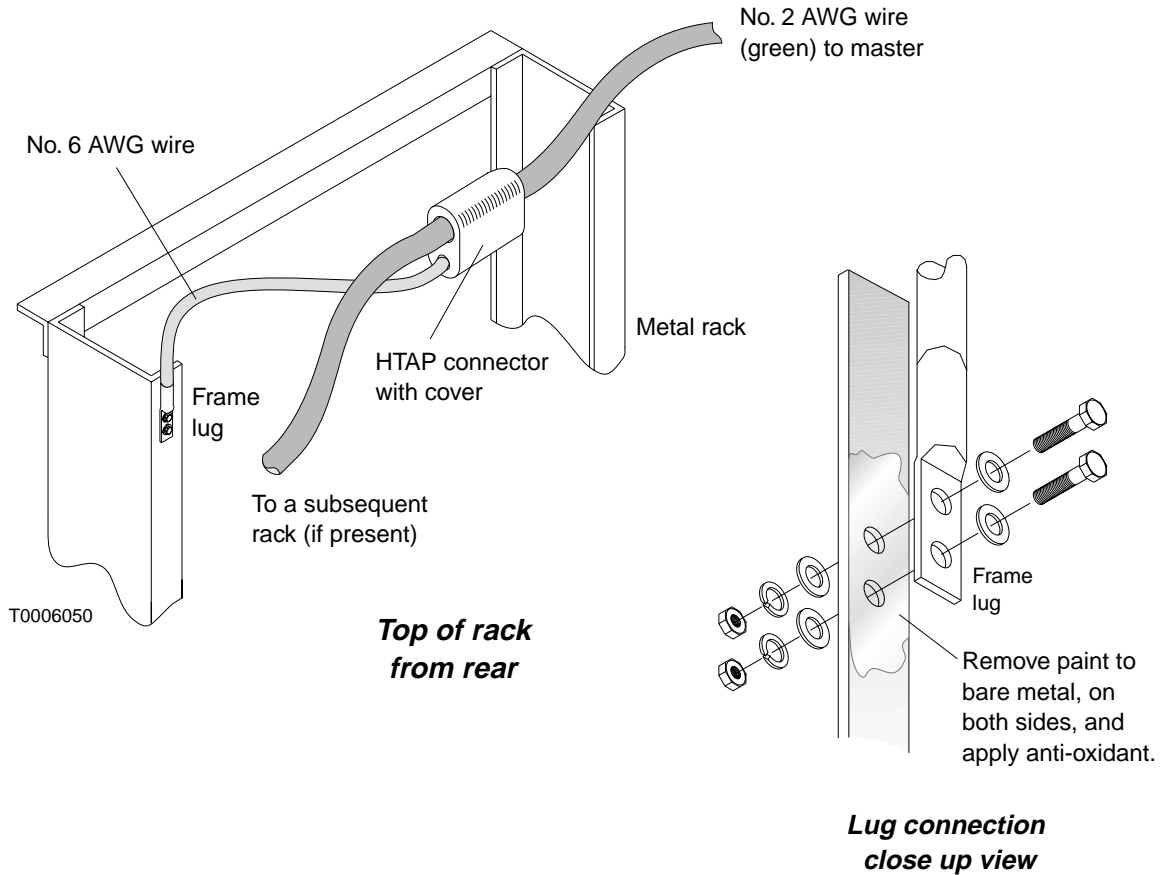
15. Use a ratchet wrench and 3/4-inch socket to tighten the lag bolt.

## Grounding the rack

Ground the rack as shown in figure 6-4:

1. Run a ground wire from the rack location to the master ground bar in the equipment room. This wire must be No. 2 AWG, green, stranded, and shielded.
2. Ground the rack by connecting a No. 6 AWG wire from the rack to the No. 2 AWG ground wire.

Use a 2-hole lug to connect the No. 6 AWG wire to the rack. Remove paint and apply anti-oxidant as shown in the illustration.



**Figure 6-4 Grounding the hub rack**

This completes mounting and grounding of the hub rack. The rack is now ready for loading with IDU chassis, power distribution, LAN hub, and hub LAN router. Configurations vary, according to the requirements of the customer's network.

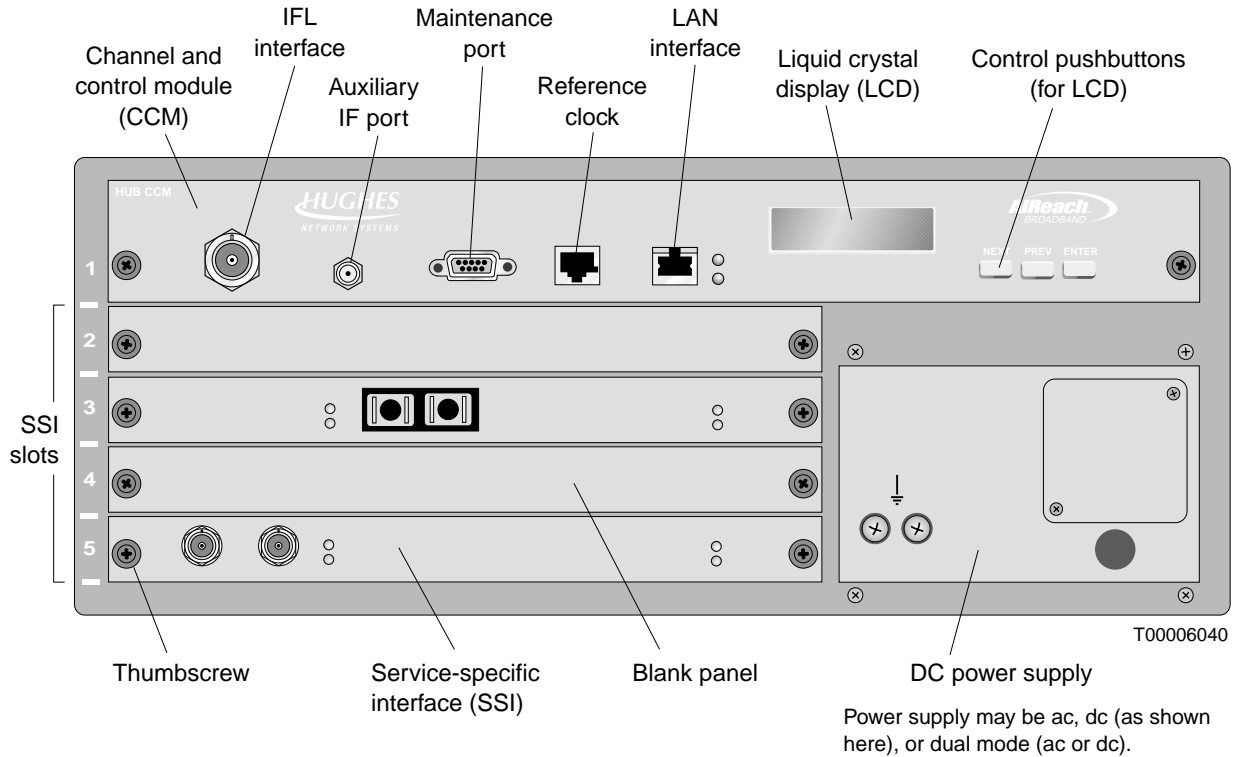
## Installing IDUs

Figure 6-5 shows the HT IDU, which consists of the IDU chassis, the channel and control module (CCM), and service-specific interfaces (SSIs). The IDU chassis is shipped with the power supply installed, but the CCM and SSIs are not installed.

*For IDU standards compliance information, see appendix B (page B-3).*

### IDU components

The main components of the IDU are identified in figure 6-5.



**Figure 6-5 HT IDU main components**

## IDU chassis types

Three IDU chassis types are available, each with a different power supply option:

**Table 6-1 IDU types**

IDU type	HNS part number
IDU chassis with ac power supply	1026356-0001
IDU chassis with dc power supply (-48 Vdc)	1026356-0002
IDU chassis with dual mode (ac or dc) power supply	1026356-0003

The power supply is not user replaceable.

### Prerequisites

Before you install the IDU chassis, make sure a power source is available. If it is not, you may have to select a different location for the IDU or install an electrical receptacle.

**Note:** The IDU is an industrial product. For safety and security reasons, it must be installed in an area that is accessible only to authorized servicing personnel.

### Mounting options

The IDU can be used on a tabletop or installed in a 19-inch (48.3-centimeter) rack. With optional adapter brackets, the IDU can also be installed in a 23-inch (58.4-centimeter) rack.

### Rack mounting

#### **Safety guidelines**

Observe these guidelines from Underwriters Laboratories Inc. (UL) when you install IDU chassis in a rack (any rack):

- Make sure the power requirements of the IDU chassis plus the cumulative power draw of other equipment in the rack do not overload the supply circuit and/or wiring of the rack.
- The IDU weighs about 20 pounds (about 9 kilograms). Have someone help you when you lift the IDU chassis to install it in the rack.
- Always load the rack from bottom to top to ensure a stable and safe rack.
- Installation of the IDU chassis within the rack system should not reduce air-flow within the rack.
- The maximum recommended ambient temperature for the IDU chassis is 50 °C (122°F).
- While installing the IDU chassis into the rack, make sure you maintain a proper earth grounding for the equipment.

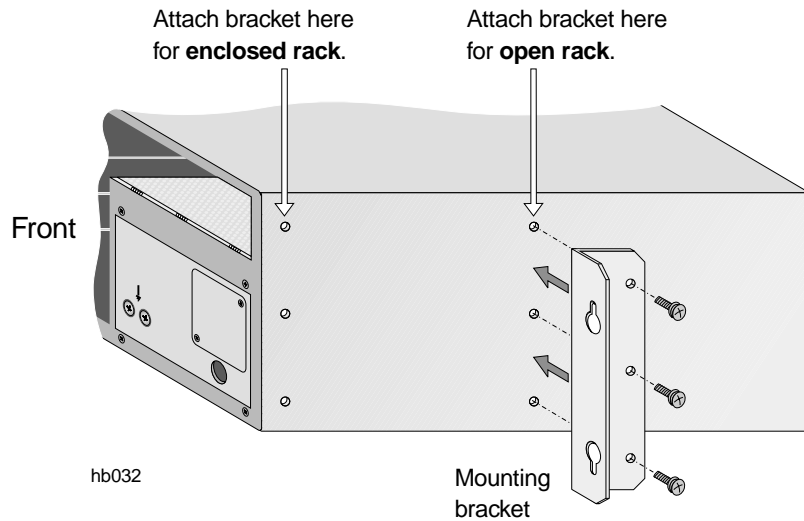
### ***Rack mounting instructions***

Mount IDU chassis as close to each other as possible to facilitate cabling.

To mount the IDU chassis in a rack, you need the rack mounting brackets included in HNS kit 1027191-0001. This kit includes two brackets and six Phillips SEMS screws for attaching the bracket to the IDU.

To mount the IDU chassis in a rack, follow these steps:

1. Attach the rack mounting brackets as shown in figure 6-6. Be sure to use the correct sets of holes (front or midpoint) for each bracket, as indicated in figure 6-6.

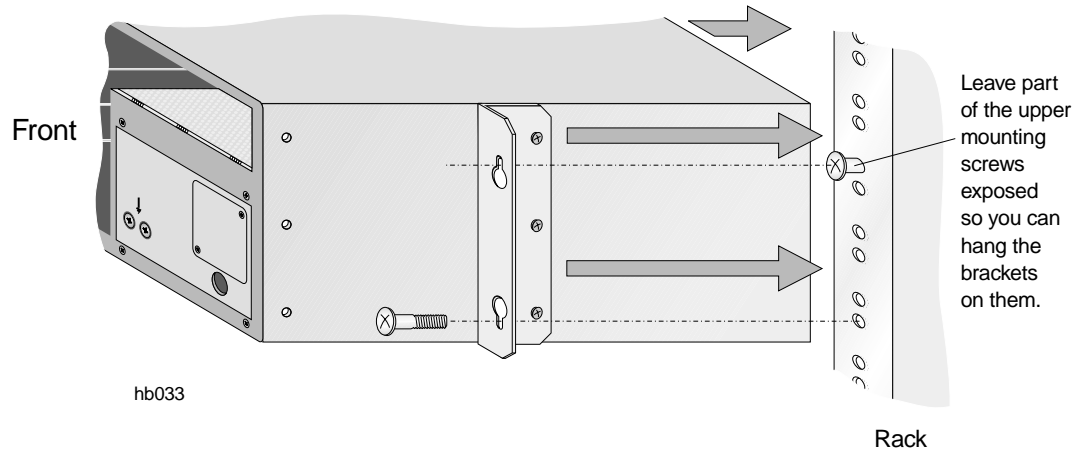


**Figure 6-6 Attaching rack mounting brackets to the IDU chassis**

2. Screw the two upper mounting screws into the rack (one on each side), at the desired installation height. Refer to figure 6-7.

Do not tighten the screws all the way—this allows you to hang the chassis by the top “teardrop” holes on the brackets (in step 3).

(The four mounting screws that screw into the rack should be provided with the rack.)



**Figure 6-7** Installing the IDU chassis in a rack

3. Place the chassis into the rack, and slip the top hole of each bracket over the heads of the upper mounting screws in the rack.
4. Support the chassis with one hand while you install and tighten the two lower screws.
5. Tighten the two upper screws.



## Power supplies

The IDU power supply is installed in the chassis at the factory. However, you need to make sure the power supply is grounded and connect power to the power supply. Detailed instructions for these steps follow.

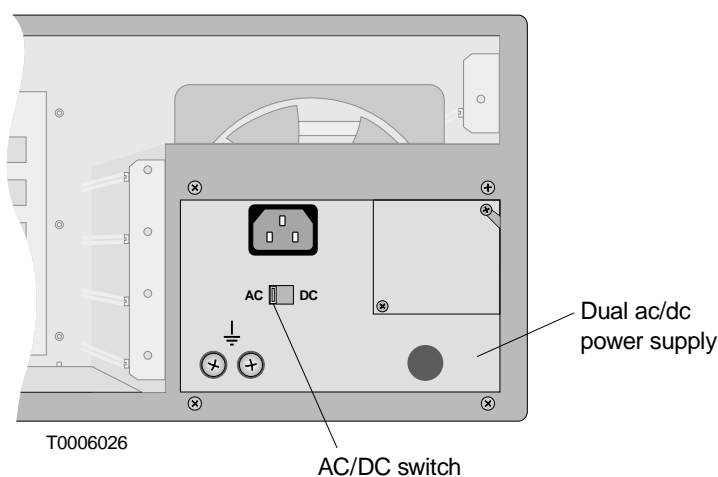
### Power supply options

The IDU chassis may be equipped with an ac, dc, or dual (ac or dc) power supply, depending on the local power environment. In the following sections, make sure you follow all instructions for the type of power supply your IDU chassis has.

**Do not attempt to replace or substitute power supplies.** If there is a problem with a power supply, return the chassis to HNS for repair or replacement.

### Dual (ac or dc) power supply

The dual ac or dc power supply (figure 6-8) can be used with an ac or dc power source. A recessed switch on the front of the power supply is used to select ac or dc operation.



**Figure 6-8** Dual ac or dc power supply

#### **Selecting ac or dc power**

Follow these instructions to set the power supply for ac or dc operation:

*To use the dual power supply with ac power:*

**Make sure the switch is in the AC position;** then follow the instructions below for ac power supplies.

**Note:** The AC–DC switch is recessed to prevent accidental switching. Use a flathead screwdriver to change the switch position.

*To use the dual power supply with dc power:*

**Make sure the switch is in the DC position;** then follow the instructions below for dc power supplies.

***Labels on dual power supply***

A label on the dual ac or dc power supply warns:

**WARNING**  
**MULTIPLE POWER**  
**CONNECTORS.**  
**DISCONNECT BOTH**  
**AC & DC POWER**  
**BEFORE SERVICING.**

**Servicing personnel must heed this warning. Note that the IDU and power supply should be serviced *only* by HNS.**

A second label on the dual ac or dc power supply advises:

**CAUTION**  
**THIS EQUIPMENT HAS A**  
**CONNECTION BETWEEN**  
**THE EARTHED CONDUCTOR**  
**OF THE D.C. SUPPLY CIRCUIT**  
**AND THE EARTHING CONDUCTOR.**  
**SEE EARTHING INSTRUCTIONS**

To disconnect dc power, unplug the terminal block (shown on page 6–19). Do not remove the wires from the terminal block while it is plugged in. If you do, the IDU chassis will not be grounded.

***Additional instructions***

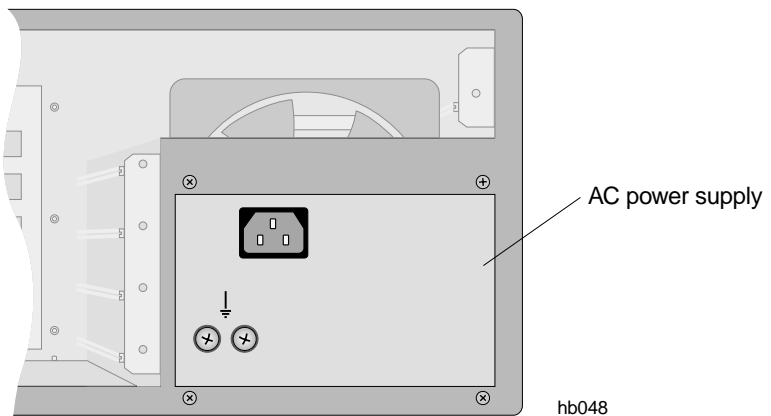
*If the power supply is a dual ac or dc unit, follow the instructions in the following sections for both ac and dc power supplies.*

## AC power supply

IDU chassis with an ac power supply (figure 6-9) or dual ac or dc power supply are equipped with a recessed IEC-320-C13 connector and a 7.5-foot (2.3-meter) power cable (HNS 9003024-0013). The power cable includes a NEMA 5-15-P plug to connect to the power source (receptacle). The cable is rated at 125 Vac, 10 amperes, and is equipped with an internal ground (earth) conductor.

The primary input requirements for the ac power supply are:

<b>Voltage:</b>	100 – 240 Vac
<b>Current:</b>	6.4 amperes maximum
<b>Frequency:</b>	50 – 60 Hz



**Figure 6-9 AC power supply**

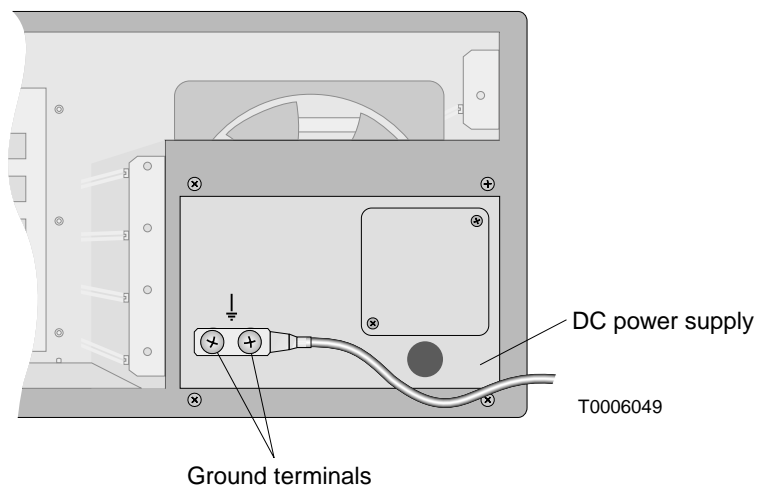
## Grounding the ac IDU chassis

**Important:** In the United States and some international markets, the required ground bond is provided by the grounding conductor in the cable and ac service conductors. If grounding is provided through the grounding conductor and service conductors, *no additional grounding is required.*

**In environments where ac grounding conductors are not available, a separate bonding conductor is required.**

If a separate bonding conductor is required, ground the ac power supply as follows:

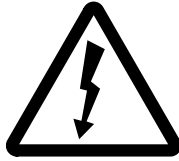
1. Use a 2-hole lug to connect a No. 16 AWG ground wire to the ground terminals on the front of the power supply. See figure 6-10.



**Figure 6-10 Ground terminals on ac power supply**

2. Connect the other end of the ground wire to the rack ground bar. If the IDU chassis is not rack mounted, connect the ground wire to a ground point such as a water pipe or building steel.

## Connecting ac power



### WARNING

The IDU chassis must be solidly bonded to a low-impedance ground (earth) source. To avoid the risk of electric shock and/or equipment damage, do not apply power to the IDU chassis without a ground reference.

---



### CAUTION

If the ODU and lightning arrestor are not connected to the IFL, do not power on the IDU chassis without first making sure the IFL is not connected to the IDU chassis. Failure to observe this instruction could result in damage to the equipment.

---

To connect ac power:

1. **Measure the voltage level of the power source to make sure it can accommodate the total IDU and ODU power requirements.**  
(The IDU supplies power to the ODU through the IFL.)  
If the voltage level cannot accommodate the IDU and ODU, the power source must be upgraded before you can proceed.
2. Connect the power cable to the IEC-320-C13 connector on the power supply.
3. Route and secure the cable to avoid physical damage.
4. Connect the plug end of the cable to a dedicated ac power source.

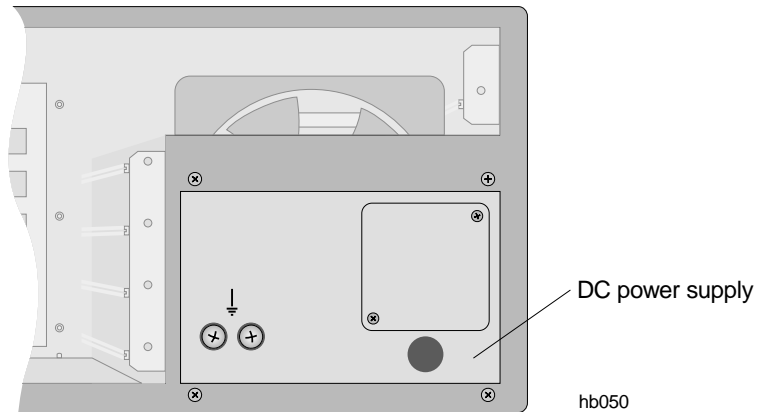
**Important: In the United States, ac-power IDU chassis must be connected to a dedicated power circuit with a 15-ampere single-pole breaker. The circuit must not include unrelated equipment.**

## DC power supply

Figure 6-11 shows an IDU chassis with a dc power supply.

A power cable is not supplied with the dc IDU chassis because cable requirements vary, depending on where the chassis will be used.

The power input requirement for the dc power supply (and dc portion of the dual ac or dc power supply) is  $-42$  to  $-56$  Vdc.



**Figure 6-11 DC power supply**

### ***Label on dc power supply***

A label on the dc power supply advises:

#### **CAUTION**

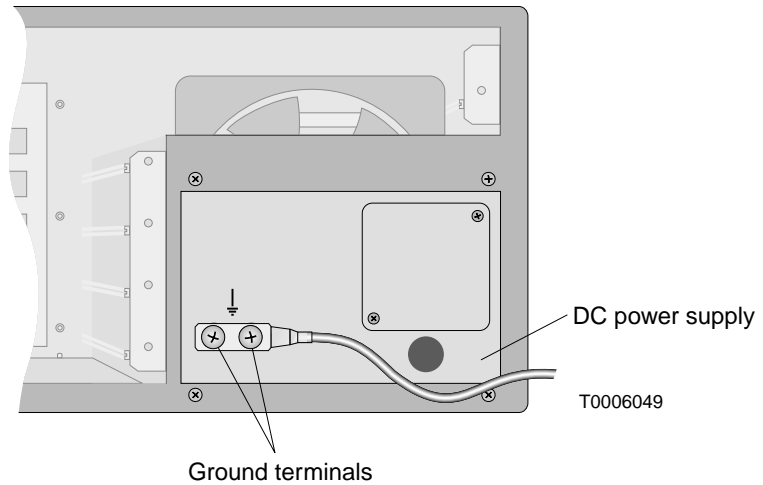
**THIS EQUIPMENT HAS A  
CONNECTION BETWEEN  
THE EARTHED CONDUCTOR  
OF THE D.C. SUPPLY CIRCUIT  
AND THE EARTHING CONDUCTOR.  
SEE EARTHING INSTRUCTIONS**

To disconnect dc power, unplug the terminal block (shown on page 6-19). Do not remove the wires from the terminal block while it is plugged in. If you do, the IDU chassis will not be grounded.

## Grounding the dc IDU chassis

Ground IDU chassis with a dc power supply as follows:

1. Use a 2-hole lug to connect a No. 14 AWG ground wire to the ground terminals on the front of the power supply (figure 6-12).



**Figure 6-12 Ground terminals on dc power supply**

2. Connect the other end of the ground wire to the rack ground bar. If the IDU chassis is not rack mounted, connect the ground wire to a ground point such as a water pipe or building steel.

## Connecting dc power



### WARNING

To avoid the risk of electric shock, remove power from the power circuit before connecting power cables to the IDU chassis power supply.



### WARNING

The IDU chassis must be solidly bonded to a low-impedance ground (earth) source. To avoid the risk of electric shock and/or equipment damage, do not apply power to the IDU chassis without a ground reference.



## CAUTION

If the ODU and lightning arrestor are not connected to the IFL, do not power on the IDU chassis without first making sure the IFL is not connected to the IDU chassis. Failure to observe this instruction could result in damage to the equipment.

---

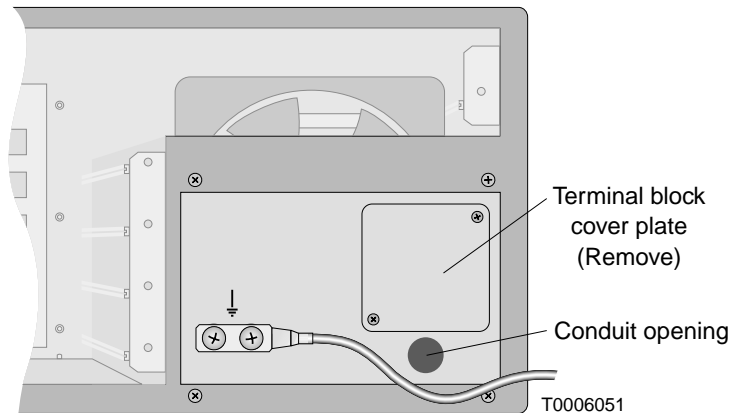
To connect power cables from the dc power source (usually a rectifier) to the dc power supply, follow the steps below.

1. **Measure the voltage level of the power source to verify it can accommodate the total IDU and ODU power requirements.**

(The IDU supplies power to the ODU through the IFL.)

If the voltage level cannot accommodate the IDU and ODU, the power source must be upgraded before you can proceed.

2. Remove power from the power circuit.
3. Loosen the two Phillips screws from the square terminal block cover plate on the front of the power supply.

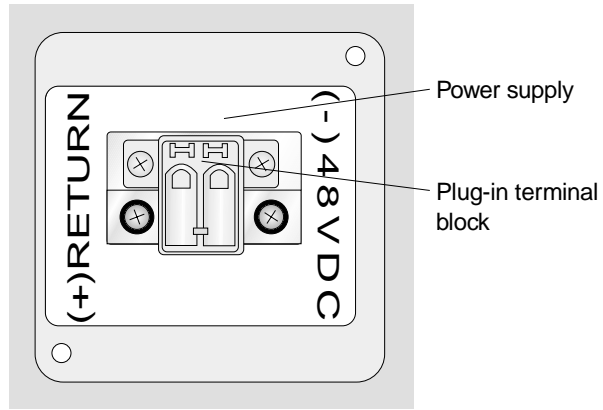


4. Rotate the protective plate to expose the terminal block.



• Follow steps 5 through 14 to insert the power cable wires into the power supply terminal block:

5. Unplug the terminal block from the power supply socket.



hb108

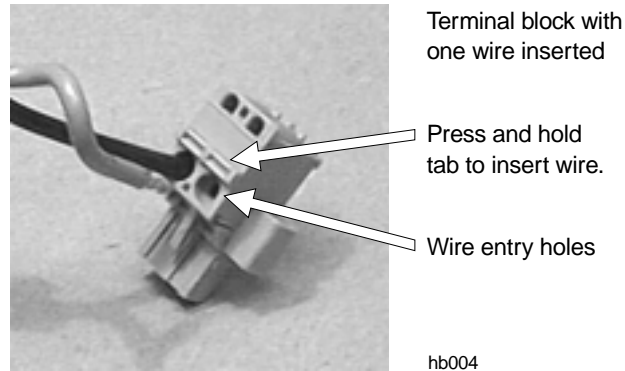
6. Strip both wires from the power source to about ¼ inch (6 centimeters) from the end.

<b>Note:</b> Wires used with the terminal block must meet these specifications:	
Composition	Solid or stranded
Wire cross-sectional area	0.2 to 2.5 square millimeters
Rated gauge	12 to 24 AWG

7. Twist the wires as shown in the photo below.
8. Insert both wires through the plastic strain relief bushing (HNS 9005614-0001).



9. Lay the terminal block on a flat surface, with the wire entry holes facing up.
10. Use a small, flat-blade screwdriver (or similar tool) to press in the tab above the wire entry hole on the terminal block. Hold the tab in.

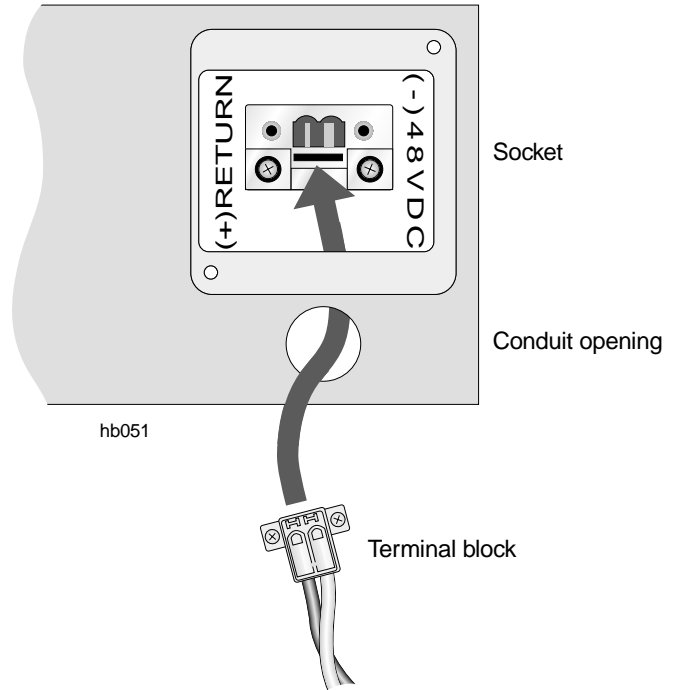


11. While holding the tab in, insert the stripped wire end.

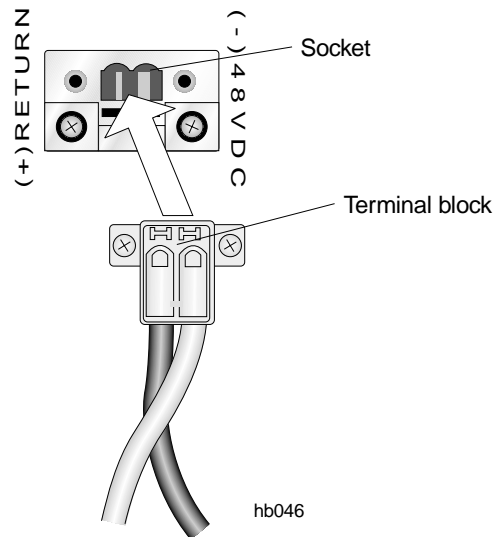
**Important:** Insert the return (+) wire from the dc power source into the terminal block so it will connect to the power supply terminal marked **(+) Return** when the terminal block is plugged in. Likewise, insert the -48 Vdc (-) wire so it will connect to the **-48 VDC (-)** power supply terminal.

12. When the wire is fully inserted, release the tab.
  13. Gently tug the wire to make sure it is securely inserted.
  14. Repeat steps 10 through 13 for the second wire.
- *At this point, both wires are inserted into the terminal block.*

15. Insert the terminal block through the conduit opening and guide it up to the socket.



16. Plug the terminal block into the power supply terminal socket.



17. Snap the strain relief bushing into the conduit opening.
18. Tighten the screw on the strain relief bushing just enough to hold the wires in place. Do not overtighten.
19. Replace the protective plate and tighten the screws.

- *This completes the power connections.*

## **Powering off the dc IDU**

The chassis does not have a power off/on switch. In normal operation, power is always on. If you need to power off the IDU:

- Break the power circuit at the rack fuse panel,
- Break the power circuit at the external fuse or circuit breaker panel, *or*
- Use an optional remote power-off circuit.

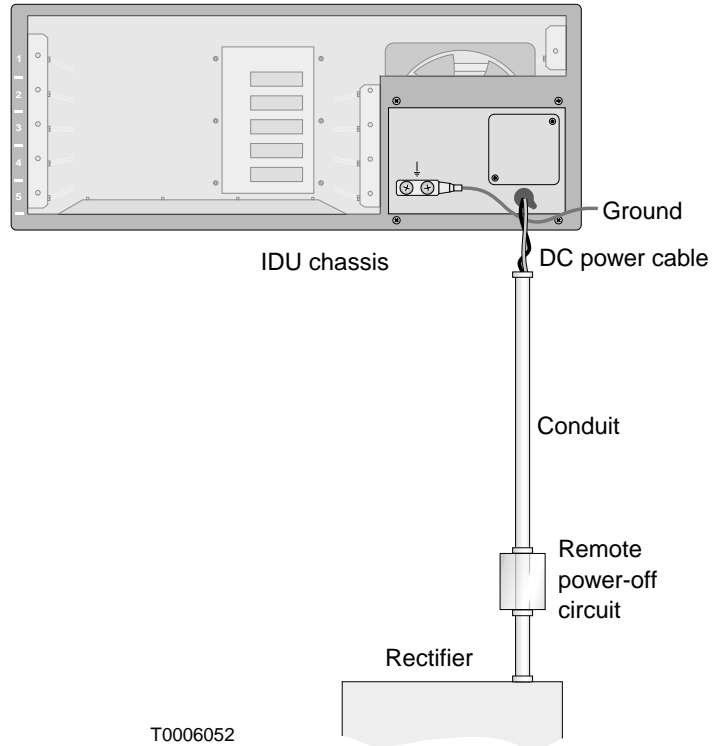
## **Remote dc power-off circuit**

**This section applies only to dc power circuits.**

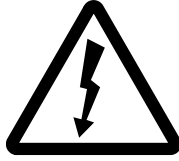
The circuit from the dc power source (usually rectifiers) to the IDU chassis must include a circuit breaker or other disconnect device that meets the following Underwriters Laboratories (UL) requirements:

**To install dc power for the IDU chassis, a readily accessible disconnect device shall be installed or should be readily available at the site where the IDU chassis is installed. The disconnect device must be a UL-listed circuit breaker rated at 60 Vdc, 6.3 amperes minimum, 15 amperes maximum.**

If the rectifier-to-chassis power circuit does not include a suitable circuit breaker, you can satisfy the disconnect requirement by including a remote power-off switch as shown in figures 6-13 and 6-14. If the power circuit already includes a suitable circuit breaker, skip this section.



**Figure 6-13** The remote power-off circuit (if needed) is installed between the IDU chassis and dc power source.

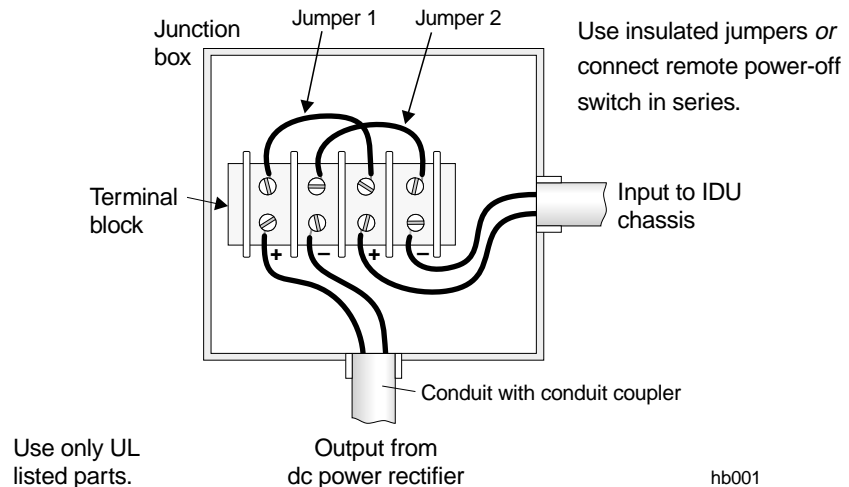


## WARNING

To avoid the risk of electric shock, make sure the dc power source breaker is off before installing a remote power-off circuit. Use a continuity tester to verify that power is off.

To install a power-off circuit (if needed), follow these steps:

1. Make sure the rectifier breaker switch is off.
2. Install a UL-approved terminal block inside a UL-approved electrical junction box as shown in figure 6-14.



**Figure 6-14 Remote power-off circuit**

3. Choose *one* of the following three options:

*If you plan to add a power-off switch later,* install jumpers 1 and 2, and replace the junction box cover. This completes the circuit installation.

*If you are installing a double-pole remote power-off switch,* use a double-pole, single-throw switch rated at 60 Vdc, 15 amperes (minimum):

In place of jumper 1, wire the switch between the (+) terminal from the rectifier and the (+) terminal from the IDU.

In place of jumper 2, wire the switch between the (-) terminal from the rectifier and the (-) terminal from the IDU.

*If you are installing a single-pole remote power-off switch, use a single-pole, single-throw switch rated at 60 Vdc, 15 amperes (minimum):*

Install jumper 1.

In place of jumper 2, wire the switch between the (-) terminal from the rectifier and the (-) terminal from the IDU chassis.

• *If you installed a switch, follow steps 4 through 9 to test the switch:*

4. Place the remote power-off switch in the open position.
5. Replace the junction box cover.
6. Turn on the dc breaker.
7. Close the power-off switch. Confirm that the chassis is receiving power.
8. Open the switch again. Confirm that the chassis is no longer powered. If the switch does not operate correctly, turn the rectifier breaker off and make sure the circuit is connected as shown in figure 6-14.
9. If the switch operates correctly, leave it in the open position with the breaker off.

*Do not install the channel and control module (CCM) or service-specific interfaces (SSIs) yet.*

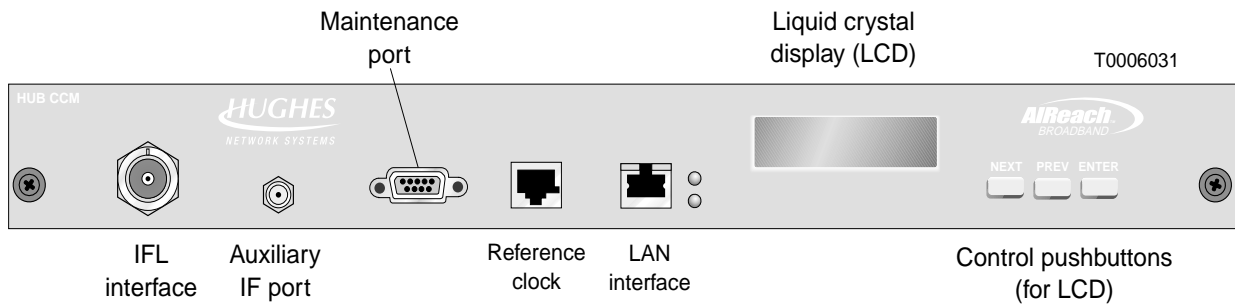
## **Power-on inspection and test**

To test the IDU chassis and power supply, perform these steps *without* a CCM or SSIs:

1. If the IDU chassis is dc powered, inspect the power supply wiring to verify that the polarity is correct.
2. Power on the IDU—*with no modules installed*; then check to make sure no breakers have tripped or fuses have blown.  
**If a breaker trips or fuse blows, be sure to troubleshoot and correct the problem before proceeding.**

## Installing the CCM


A channel and control module (CCM) must be installed in the top slot (slot 1) of the IDU chassis. For an HT IDU, the CCM must be a CCM HT (HNS 1027181-0001), as shown in figure 6-15.



**Figure 6-15 CCM HT**

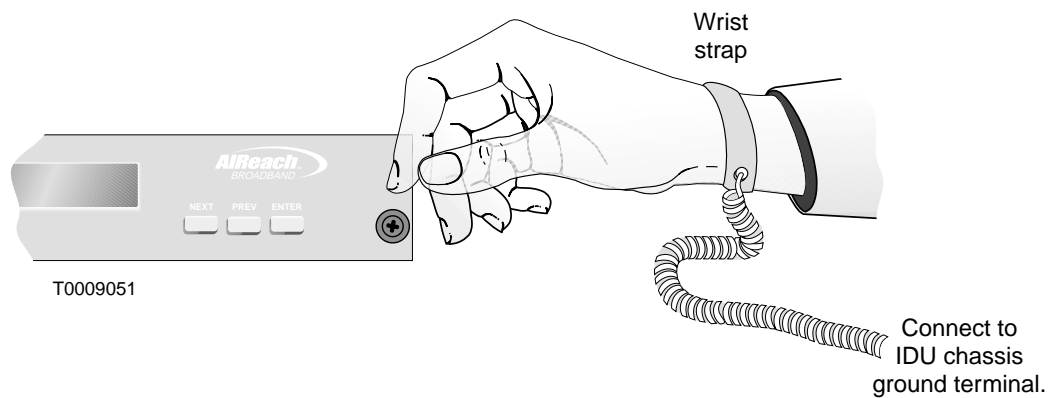
The CCM supports the interface modules installed in the IDU chassis by performing control, bus, upconversion, and downconversion functions. These modules—SSIs—are described in section 6.5.

To install the CCM HT, follow the steps below:



**CAUTION**

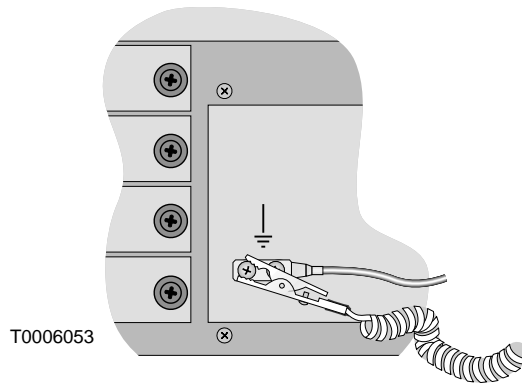
Always wear a new or recently tested electrostatic discharge (ESD) wrist strap (figure 6-16) when handling circuit modules. Failure to use a wrist strap may result in damage to components.



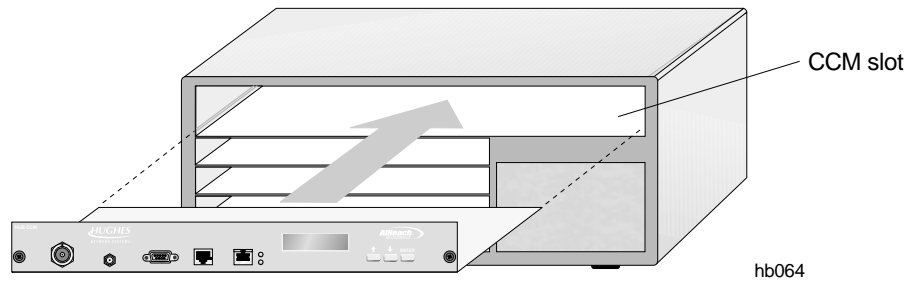
**Figure 6-16 ESD wrist strap**



1. Wrap the ESD strap snugly around your wrist and connect the alligator clip to one of the ground terminals on the IDU chassis power supply.



2. Remove the CCM from its ESD protective packaging. **Retain the packaging in case it is necessary to return the CCM for repair.**
3. Slide the module into the guides on each side of the top chassis module slot (slot 1) and push it firmly into place until the CCM front panel is flush with the front of the chassis.



4. Tighten the thumbscrews at each end of the CCM. To tighten the thumbscrews, push them toward the IDU chassis and turn them clockwise. To fully tighten the thumbscrews, use a Phillips screwdriver.

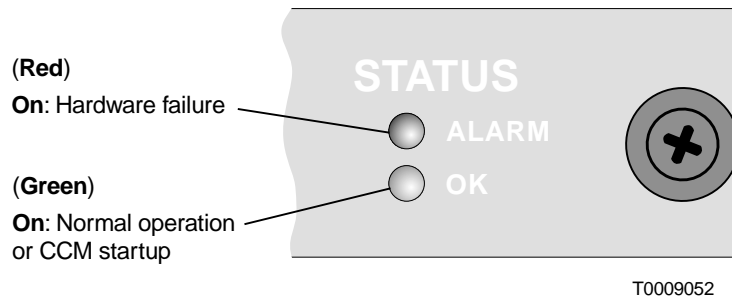
### CCM LAN and clock interfaces

The CCM HT LAN interface (shown in figure 6-15) is an RJ-48 connector that connects the IDU to the hub LAN router, which provides connectivity to the Element Management System (EMS). The LAN interface supports 10BaseT, up to 10 Mbps.

The reference clock interface (shown in figure 6-15) is also a RJ-48 connector. It connects the customer's clock distribution network to the IDU. (The EMS operator has to configure the IDU to accept an external clock.)

### LED indications

The CCM LED indications are explained in the following illustration:



## 6.5

### SSIs

Service-specific interface modules (SSIs) provide interfaces to support specific network services. SSI types used depend on the needs of the customer network.

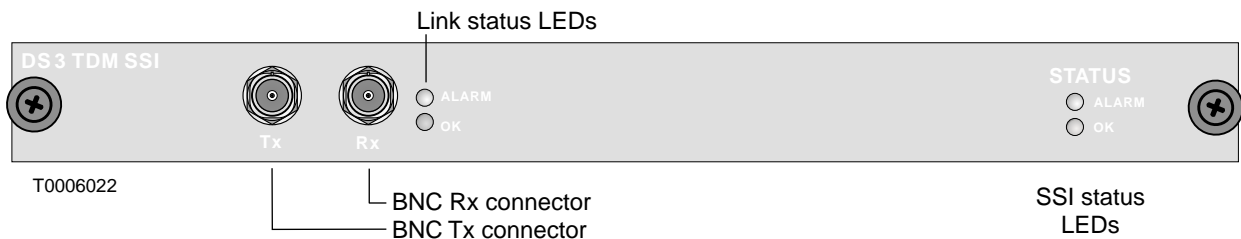
The following SSIs can be installed in the HT IDU chassis:

- DS3-TDM SSI (HNS 1027094-0001)
- OC3c-ATM (HNS 3003136-0003)
- DS3-transparent (HNS 1027094-0002)

**The OC3c-ATM SSI is installed in chassis slot 3 only, and the DS3-TDM SSI is installed in slot 5 only.**

### DS3-TDM

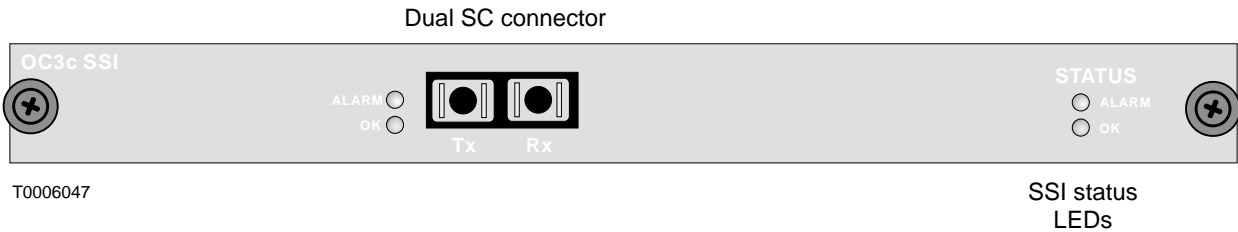
The DS3-TDM SSI, shown in figure 6-17, provides a structured or transparent D3 service link between the HT and RT.



**Figure 6-17 DS3-TDM SSI**

The maximum cable length for a DS3-TDM SSI is 450 feet (137.2 meters).

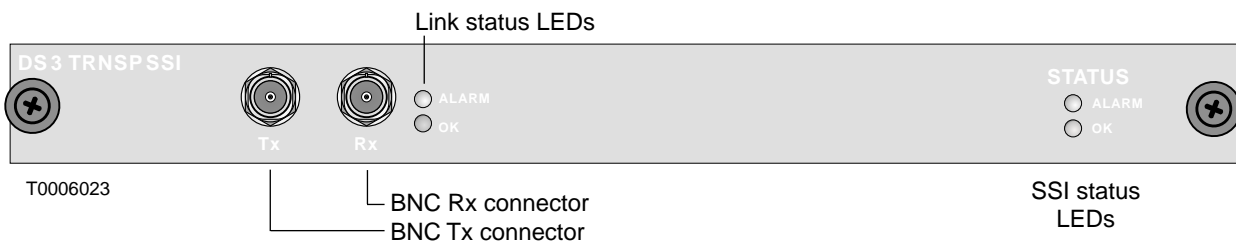
**OC3c-ATM** The OC3c-ATM SSI, shown in figure 6-18, provides an OC3c physical interface and provides ATM cell queuing and multiplexing for over-the-air transmission.



**Figure 6-18 OC3c-ATM SSI**

The maximum cable length for an OC3c-ATM SSI is 1,000 feet (305 meters).

**DS3-transparent** The DS3-transparent SSI, shown in figure 6-19, provides a direct point-to-point link between the HT and RT.



**Figure 6-19 DS3-transparent SSI**

The maximum cable length for a DS3-transparent SSI is 450 feet (137.2 meters).

### SSI physical configuration

Look at the hub network schematic or other configuration document to determine:

- How many SSIs to install
- What type(s) of SSIs to install
- Which SSI to install in each IDU chassis slot

#### Important:

- **Install the OC3c-ATM SSI in chassis slot 3 only.**
- **Install the DS3-TDM SSI in slot 5 only.**

## Installing SSIs

Follow these steps to install SSIs:

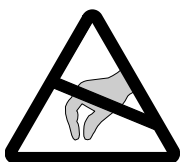


### CAUTION

To maintain proper airflow and protect against RF interference, keep any empty chassis slots covered with blank panels.

---

1. If a blank panel is installed in the slot where you will install the SSI, loosen the thumbscrews on the blank panel and remove it.  
Keep the blank panel for future use.



### CAUTION

Always wear a new or recently tested electrostatic discharge (ESD) wrist strap (figure 6-20) when handling circuit modules. Failure to use a wrist strap may result in damage to components.

---

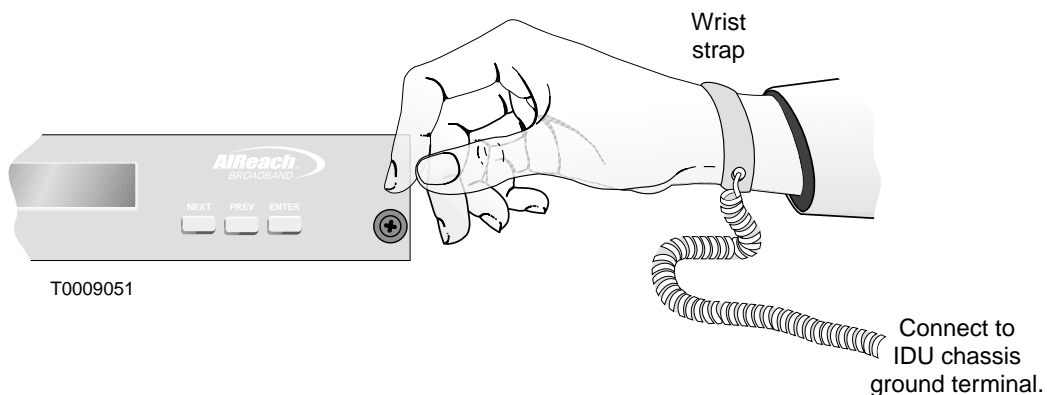
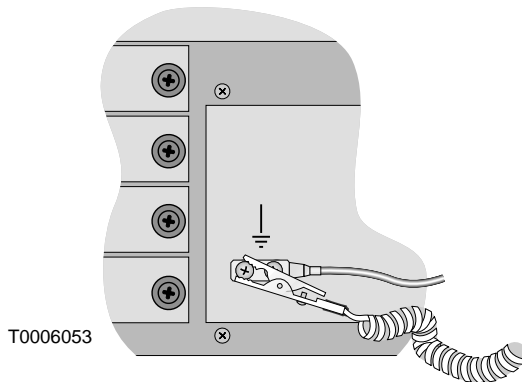
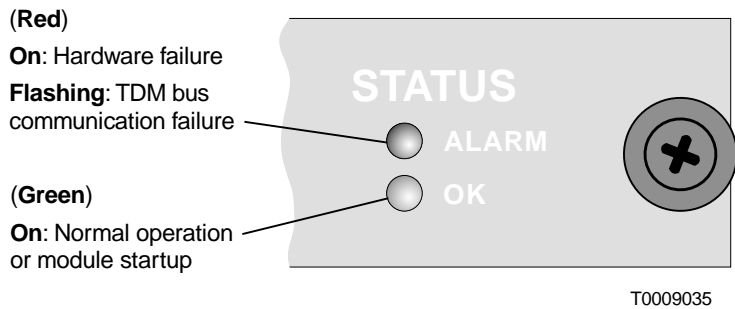


Figure 6-20 ESD wrist strap

2. Wrap the ESD strap snugly around your wrist and connect the alligator clip to one of the ground terminals on the front of the IDU chassis power supply.



3. Remove the SSI from its ESD protective packaging.  
**Retain the packaging in case it is necessary to return the SSI for repair.**
4. Slide the SSI into the guides on each side of the chassis SSI slot and push it firmly into place until the front of the SSI is flush with the front of the IDU chassis.
5. When the SSI receives power through contact with the IDU backplane, it automatically initiates startup diagnostics. Watch the LEDs to see the diagnostic results:



6. Tighten the thumbscrews at each end of the SSI.  
To tighten the thumbscrews, push them toward the IDU chassis and turn them clockwise. To fully tighten the thumbscrews, use a Phillips screwdriver.
7. Repeat steps 1 through 6 for each SSI.
8. If any SSI slots are empty, cover the slot with a blank panel.  
(If you need additional blank panels, order HNS part 1026730-0001.)

*This completes the IDU installation.*

## SSI LEDs

LEDs on SSIs show:

- Module status (all SSIs)
- Link status (if applicable)

The subsections below show which LEDs are included on each SSI and explain the meaning of the various LED on-off conditions.

### **Module status LEDs**

Included on: All SSIs

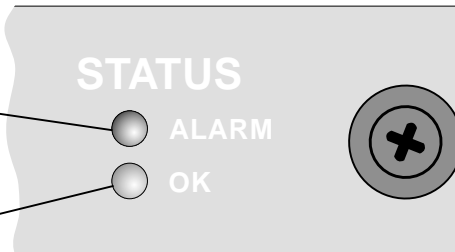
(Red)

**On:** Hardware failure

**Flashing:** TDM bus communication failure

(Green)

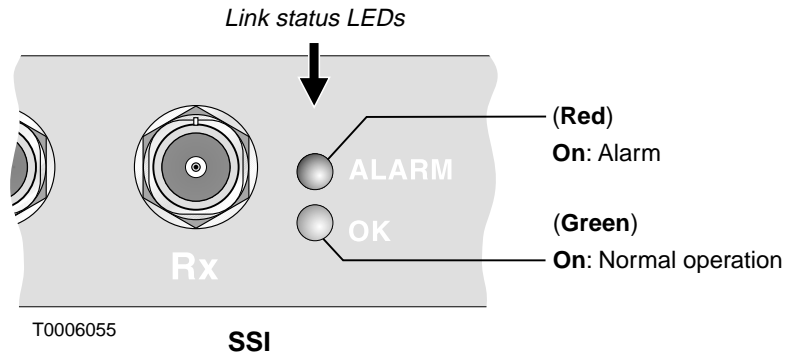
**On:** Normal operation or module startup



T0009035

### **Link status LEDs**

Included on: DS3-TDM, OC3c-ATM, and DS-3 transparent SSIs



T0006055

SSI

## Connecting the IFL to the CCM

Connect the IFL cable to the CCM:

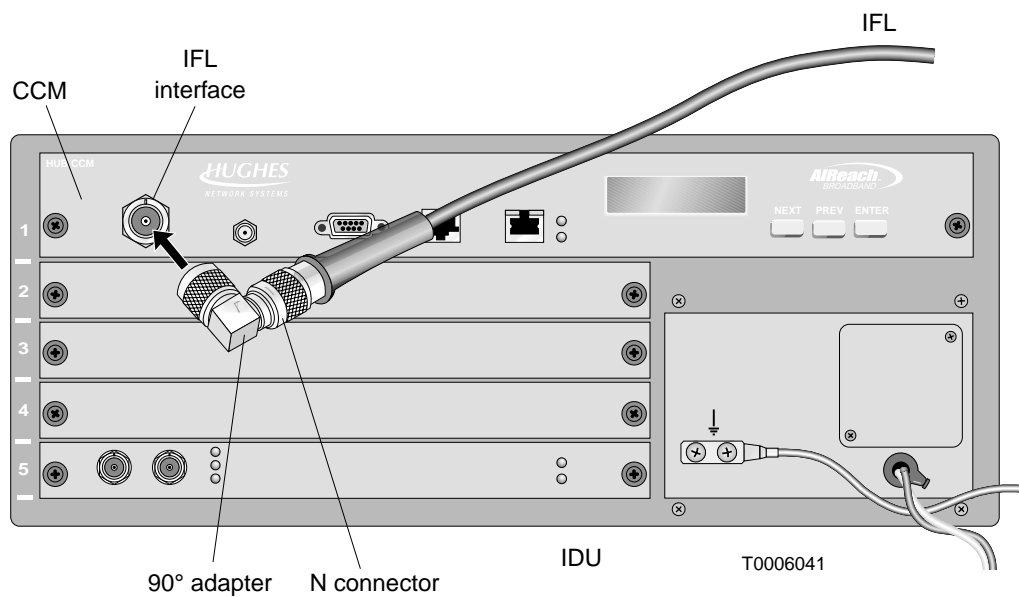
1. **Make sure power to the IDU is off (or disconnected).**

A label on the CCM front panel advises:

CAUTION: POWER DOWN  
ODU BEFORE CONNECTING  
OR DISCONNECTING IF

Removing power from the IDU powers down the ODU. Make sure the IDU is powered off before you connect or disconnect the IFL cable.

2. Using a 90° adapter, connect the IFL to the CCM IFL interface, as shown in figure 6-21.



**Figure 6-21 Connecting the IFL cable**

**For each IDU to be installed, repeat all applicable steps in sections 6.2 through 6.6 (pages 6-7 through 6-33).**

## Redundancy bus cable

If a backup HT has been installed, a CCM redundancy bus cable (HNS 1028130-0001) must be installed, as shown in figure 6-22. This cable connects up to five IDUs. It is used for HT IDUs only.

Connect the cable from (DB-9) maintenance port to maintenance port, as shown in figure 6-22. If the IDUs cannot be installed close enough to each other to connect the cable, an extender cable is available.

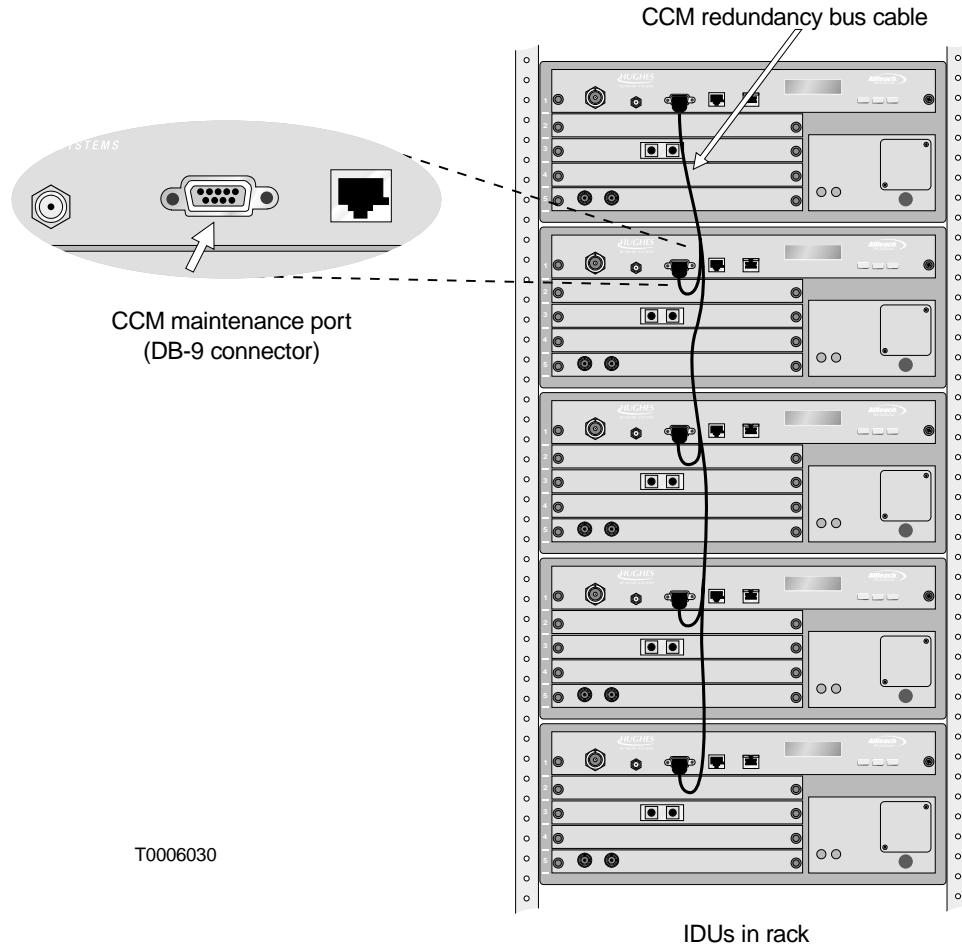


Figure 6-22 HT IDUs connected by CCM redundancy bus cable

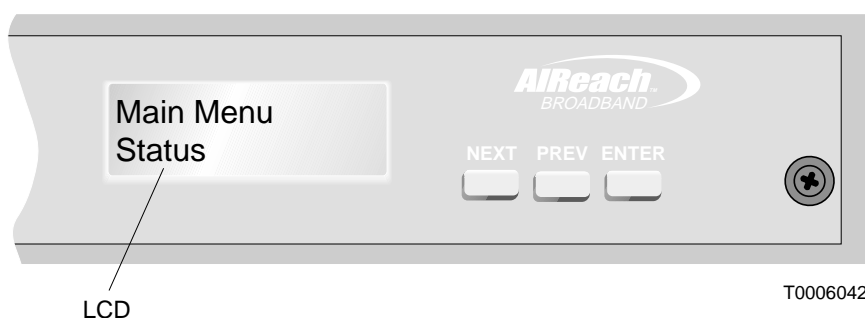


## Front panel LCD operation

The text display (LCD) on the CCM front panel (figure 6-23):

- Shows CCM startup diagnostics (SUDS) tests as they occur
- Shows the system boot up sequence
- Shows the software loading sequence
- Indicates the status and operational state of system components
- Provides functions necessary for commissioning the HT

You will use the LCD (liquid crystal display) and buttons on the CCM front panel to conduct the test and checks described in sections 6.9 and 7.3.



**Figure 6-23 CCM front panel LCD**

### Accessing the LCD Main Menu

When the CCM/ IDU is powered up or reset:

- SUDS run automatically.
- When SUDS are completed, the CCM LCD displays a SUDS Completed message.
- The LCD then displays:

Initializing  
Press Enter for Menu

To access the CCM LCD Main Menu, press the ENTER button on the CCM front panel while the Initializing screen is displayed.

This puts the IDU into diagnostic mode. The LCD shows the Main Menu:

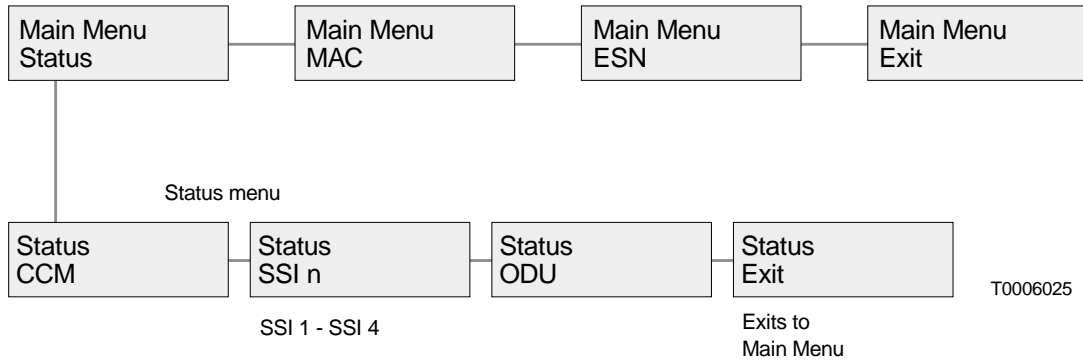
Main Menu  
Status

**Note:** After the CCM downloads its software and is operational, you can access the Main Menu by pressing Enter.

## LCD menu map

The menu map below (figure 6-24) shows the available menu options for HTs.

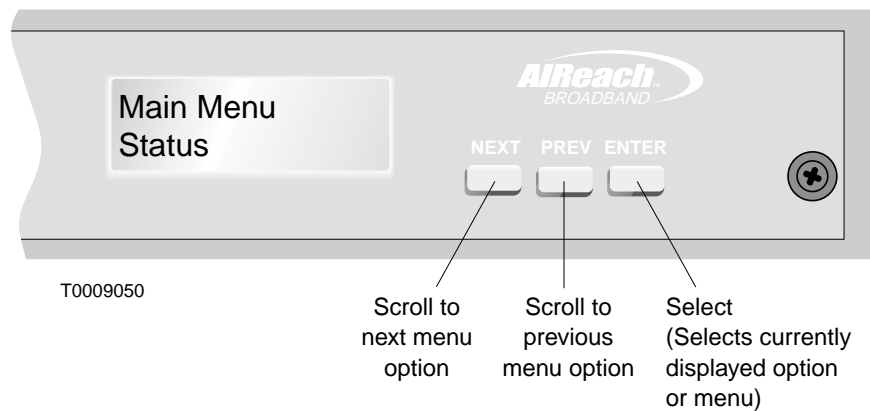
**Note:** Menu options are not the same for RTs and HTs.



**Figure 6-24** LCD menu map for CCM HT

## CCM button functions

The CCM button functions are explained in figure 6-25:



**Figure 6-25** CCM front panel button functions

### Exit options

If you select Exit from the Main Menu . . .

. . . *while the system is operating*, it remains in operational mode.

. . . *when the system is not in operational mode*, the CCM reboots.

If you select Exit from the Status menu, the display returns to the Main Menu.

## CCM power-on test

To prepare to commission the HT (chapter 7), you:

- Perform a CCM power-on test (this section)
- Check the status of each main component (section 7.3)

The objective is to verify that the equipment is operational *before* commissioning. If you find a problem, you can correct it prior to commissioning so it will not delay the commissioning process.

### Check connections

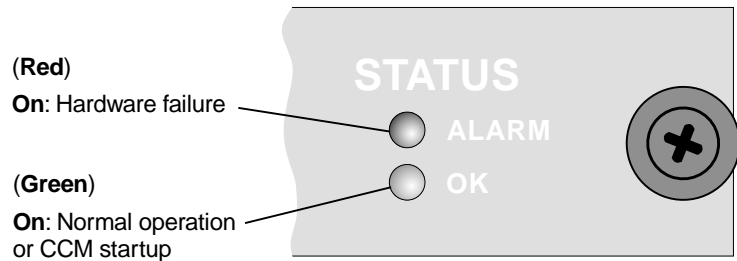
Before you conduct the power-on test, make sure all AIReach Broadband equipment is properly connected.

1. Check these connections, **with power to the IDU off**:
  - IDU to ODU (IFL from IDU to lightning arrester and from lightning arrester to ODU)
  - ODU ground connections
  - IDU ground connections (if required)

### CCM power-on test (SUDS)

Test the CCM for proper operation, as follows:

1. Apply power to the IDU chassis.
2. Observe the LEDs on the CCM front panel:



T0009052

3. Also observe the CCM startup diagnostics (SUDS) on the CCM's front panel LCD:

(For the tests and status checks described in this chapter, the HT does not have to be connected to the EMS.)

SUDS start on powerup. While they run, the CCM front panel shows the following messages, in the sequence shown.

**Equipment function is normal when you see the messages shown below and no failure messages.**

***Initial powerup***

SUDS CPU Reg OK
SUDS DRAM OK

CPU registers and dynamic RAM are tested.

***Timer test***

SUDS Timer Test
-----------------

Timers are tested.

***Watchdog timer test***

SUDS WDT Test
---------------

The watch dog timer is tested.

***PCI test***

SUDS PCI Test
---------------

The PCI controller is tested.

***Static dual port RAM test***

SUDS SDPRAM Test
------------------

Static dual port RAM is tested.

***Serial port 1 test***

SUDS Ser 1 Test
-----------------

Serial port 1 is tested.

### **Serial port 2 test**

SUDS Ser 2 Test

Serial port 2 is tested.

### **LAN ID test**

SUDS LAN ID Test

LAN PCI registers are configured and the LAN ID is read from the LAN controller.

### **Successful test completion**

This message indicates that startup diagnostics have successfully completed:

SUDS Completed

### **Failure indication**

If a failure occurs during any of the tests listed above, the LCD message sequence stops. The LCD shows the test that failed on the first line and **FAILED** (flashing) on the second line, as in the example below.

SUDS Ser 2 Test  
FAILED

This screen indicates that serial port 2 failed diagnostics.

The LCD remains inactive unless you power the CCM off, then on. This restarts SUDS.

**If any CCM component fails, replace the CCM.**

After SUDS are complete, the LCD displays the CCM boot up sequence. At this point, you only need to verify that SUDS have completed.

## 6.10

---

### **Hub LAN router and LAN hub**

The AIReach Broadband hub LAN uses a Cisco 2611 (DC) modular router and a Cisco 1924 (DC) Ethernet hub switch, which connects to the router.

For installation and configuration information, refer to the Cisco documentation. (The router must be configured for EMS–hub communication.)

For detailed specifications, see the *Hub and Remote Terminal Site Preparation Guide* or the Cisco documentation.

## Chapter 7

# Commissioning HTs

---

This chapter includes:

- Prerequisites for commissioning – page 7-2
- HT commissioning procedure – page 7-3
- Checking component status – page 7-7
- HT to RT connection tests – page 7-11

Commissioning refers to verification procedures to ensure that the newly installed hub terminal (HT) is operational.

**Note:** Most references in this chapter are to an HT. A hub may consist of one HT but usually consists of multiple HTs. Each HT—an ODU, IFL, and IDU—must be commissioned separately.

## Prerequisites for commissioning

To ensure successful commissioning, you must verify that the prerequisites listed below have been accomplished. These tasks must all be completed *prior to* commissioning. If any of them has not been done, make sure they are completed before you proceed with commissioning.

- The HT ODU, IFL, and IDU must be installed and connected.
- The Element Management System (EMS) hardware and software must be installed and operational.
- All physical LAN connections between the HT and EMS must be completed and operational.

If the EMS is remote from the HT, the entire end-to-end link must be verified as operational. The EMS must be able to ping the hub LAN router and the specific port to be connected to the HT.

- The EMS database must be loaded and operational.
- The EMS operator has to enter the HT MAC address and configure the HT in the EMS database.  
(The HT MAC address is printed on a tag attached to the CCM and can also be read from the CCM LCD—from the Main Menu MAC display.)
- The CCM must be installed in the IDU. (SSIs are not required for commissioning.)
- Configure EMS and hub routers for EMS-hub communication.
- The hub router boot relay agent must be configured to forward boot requests from the HT to the EMS.
- If a backup HT has been installed, a CCM redundancy bus cable must be connected.

## HT commissioning procedure

To commission the HT, you apply power and observe the CCM LCD while the HT downloads software and configuration data from the EMS. This verifies that the HT equipment is operational. (However, the HT is not ready for service until SSIs have been configured by the EMS operator.)

### Summary

To observe software and configuration downloading, you power up the IDU and observe the LCD on the CCM front panel. The CCM displays the following sequences:

- Startup diagnostics (SUDS)
- Boot up
- Software loading
- Configuration loading

After configuration loading, the LCD shows this message:

HT    Freq 1A1 Disabled	————— (Frequency is specific to HT)
----------------------------	-------------------------------------

This display signals that downloading has completed, which demonstrates that the equipment is operational. The HT is disabled until SSIs are installed and configured (through the EMS). When SSIs are installed and configured, the operational status is HT Enabled.



## Startup diagnostics (SUDS) sequence

Startup diagnostics (SUDS) begin when the CCM is first powered up. SUDS test the CCM's components individually

1. Apply power to the IDU/CCM, and observe the SUDS sequence on the LCD:

For test identification details, see chapter 6, section 6.9.

SUDS CPU Reg OK  
SUDS DRAM OK

SUDS Timer Test

SUDS WDT Test

SUDS PCI Test

SUDS SDPRAM Test

SUDS Ser 1 Test

SUDS Ser 2 Test

SUDS LAN ID Test

**If all diagnostics complete successfully, the SUDS sequence ends with a SUDS Completed message, as shown below.** If a test fails, the specific test that fails is shown with a FAILED message, as shown below.

SUDS Completed

or

SUDS Ser 2 Test  
FAILED

The LCD remains inactive unless you power the CCM off, then on. This restarts SUDS.

**If any CCM component fails, replace the CCM.**

## Boot up sequence

After successful completion of startup diagnostics, the CCM begins the boot up sequence. A CCM restart (or soft reboot—without loss of power) also initiates boot up.

2. Observe the boot up sequence:

### **Hardware Initialization**

Initializing

The CCM hardware components are initialized.

Several devices are initialized. If the baseband signal processor (BSP) is unable to initialize the device, the hardware is reset and another attempt to initialize occurs. If a device fails to initialize, it is reported on the second line of the LCD—for example:

Initializing  
PLX Failed

The devices that are checked for initialization are listed below. In the event of failure, any of these devices could appear on the second line of the LCD (with “Failed”).

Device name on LCD	Device
Host Cfg	Vrc4375 PCI controller
PLX	PLX9050
PLX IO	PLX IO devices
LAN	LAN controller
RCC FPGA	RCC FPGA
BSB FPGA	Baseband FPGA
QPIG FPGA	QPIG FPGA
Tim Syn	Timing synthesizer

**If any CCM component fails, replace the CCM.**

### **Sending Boot Request**

Boot

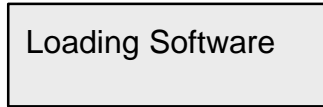
Boot request is being sent to BOOTP server.

If the CCM does not receive a Boot Reply message, the boot up sequence restarts (with hardware initialization). If, for example, the EMS is not operational (and therefore no Boot Reply message can be sent), the CCM will not progress beyond the Boot display shown above.

## Software loading

When the CCM receives a boot reply message from the EMS boot server, it begins to load its operational software.

3. Observe the Loading Software message on the LCD:



If the CCM is unable to load its software, the LCD returns to the boot up sequence.

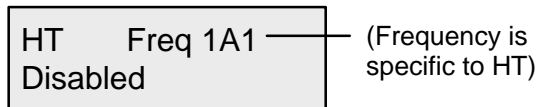
## Configuration loading

After loading its software, the CCM loads its configuration data.

## Operational state

After loading its configuration information, the CCM becomes operational. This is indicated by HT Disabled on the LCD.

4. Watch for HT Disabled on the LCD:



**This display signals that downloading has completed, which demonstrates that the equipment is operational.**

The HT is disabled, but operational, until SSIs are installed and configured (through the EMS). When SSIs are installed and configured, the HT is ready for service, and the operational status is HT Enabled.

The possible operational states are:

Enabled	HT is ready for service.
Disabled	Equipment is operational, but HT is not ready for service.
Degraded	One or more components is not fully operational.
Enabled Degraded	HT is ready for service, but one or more components is not fully operational.
Enabled In Test	All of the HT's SSI are in test mode.

## Checking component status

Use the LCD Status option to check the status of the CCM, SSIs, and ODU, as explained in the following sections.

### Check CCM status

Check the CCM status as follows:

1. Press Enter on the CCM front panel.

The LCD shows:

Main Menu  
Status

2. Press Enter, to go to (select) the Status menu:

Status  
CCM

3. Press Enter to show the CCM status:

CCM  
OK

The possible status conditions for CCMs, SSIs, and the ODU are:

OK	The component is operational.
Degraded	The component is not fully operational.
Failed	The component has failed.
Unknown	The CCM cannot communicate with the component.

### **Action for “Failed” or “Degraded” status**

**If the LCD shows Failed for any component, replace the component.**

If you see **Degraded** during installation, replace the component. However, if you see **Degraded** while the system is operation, under some circumstances you may not need to replace the component (for example, if a failed port is not needed).

## Check SSI status

Check the status of the installed SSIs as follows:

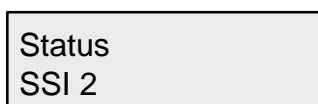
(Note that SSIs are not required for commissioning. They can be installed after HT commissioning.)

1. From the **Status / CCM** display, shown below,



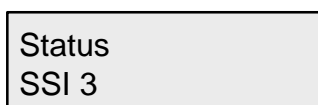
A rectangular display box with a light gray background and a black border. The text inside is "Status" on the top line and "CCM" on the bottom line.

press the NEXT button to scroll to the SSI status menu:



A rectangular display box with a light gray background and a black border. The text inside is "Status" on the top line and "SSI 2" on the bottom line.

2. Press NEXT or PREV to scroll to the SSI you want to check:



A rectangular display box with a light gray background and a black border. The text inside is "Status" on the top line and "SSI 3" on the bottom line.

**Note:** SSIs are numbered SSI 1 through SSI 4, according to their positions in the IDU chassis:

Chassis slot	SSI number
2	1
3	2
4	3
5	4
Slot 1 is occupied by the CCM.	

3. Press Enter to show the status of the selected SSI:



A rectangular display box with a light gray background and a black border. The text inside is "SSI 3" on the top line and "OK" on the bottom line.

The possible status conditions for SSIs are:

OK  
Degraded  
Failed  
Unknown

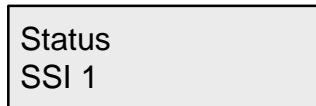
(as explained on page 7-7)

**Check the status of each installed SSI.**

## Check ODU status


Check the status of the ODU as follows:

1. From the **Status / SSI 1** display, shown below,



A rectangular box representing a screen display with the text "Status" on the top line and "SSI 1" on the bottom line.

press the NEXT button to scroll to the ODU status menu:



A rectangular box representing a screen display with the text "Status" on the top line and "ODU" on the bottom line.

2. Press Enter to show the ODU status:



A rectangular box representing a screen display with the text "ODU" on the top line and "OK" on the bottom line.

The possible status conditions for the ODU are:

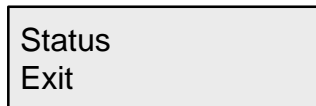
OK  
Degraded  
Failed  
Unknown

(as explained on page 7–7)

**Note:** You will not see ODU status information if the ODU is not connected (via the IFL) to the IDU. The status will be Unknown.

**If a failure is indicated for any component, replace the failed component.** Run SUDS, and check the status of the new component.

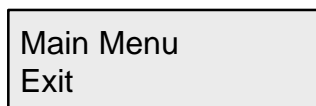
3. Exit the Status menu: Scroll to:



A rectangular box representing a screen display with the text "Status" on the top line and "Exit" on the bottom line.

and then press ENTER.

4. Exit the Main Menu: Scroll to:



A rectangular box representing a screen display with the text "Main Menu" on the top line and "Exit" on the bottom line.

and then press ENTER.

*At this point, HT commissioning is complete, except for the HT to RT tests described in section 7.4. You may or may not be able to complete these tests, depending on whether or not other network components are installed and operational. (See the test requirements listed in section 7.4.)*

**Leave the HT powered on for testing and operation.**

## HT to RT connection tests

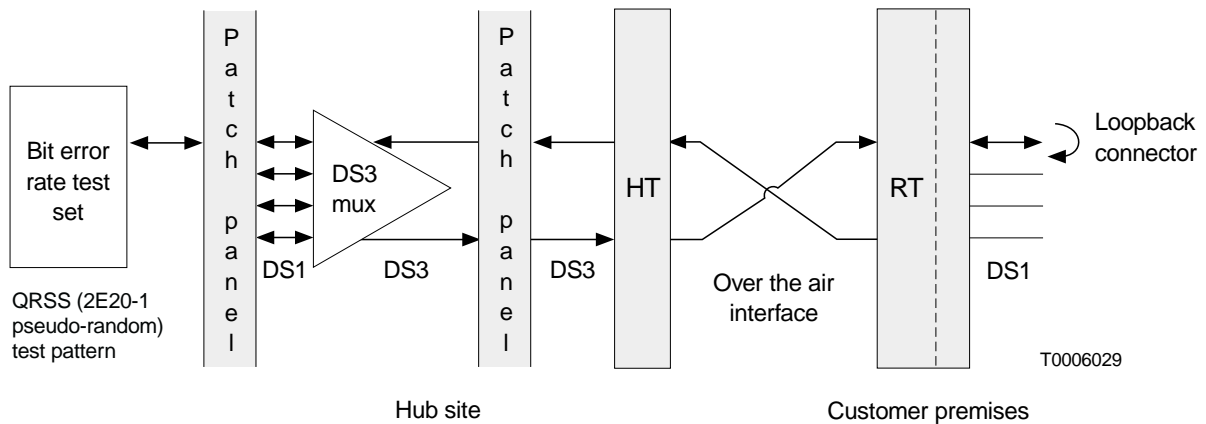
Perform the applicable tests described below if the newly installed HT meets the listed requirements. If the HT does not yet meet these requirements, perform the tests at a later time.

**DS1 test** This test verifies the DS1 connection from the HT to the RT.

### Requirements

The DS1 test described below requires the following:

- The HT must be operational and in contact with the EMS.
- The RT must be fully installed, commissioned, and in contact with the EMS through the hub.
- DS1 services must be configured and provisioned.
- There must be no alarms present at the RT location.
- A loopback connector must be connected to the input/output port connector of the RT SSI used for the test, as illustrated in figure 7-1.



**Figure 7-1 HT to RT connection test setup**

### Test procedure

1. Connect a DS1 test set to the out/input points at the patch panel.
2. Select:
  - QRSS (quasi random signal source) test pattern
  - Recovered clock
  - DS1 interface
3. Run the test for 1 hour.

### Results

The HT passes if there are no errors and no clock or frame slips during the test.

Record the results on the form on the following page (or make a photocopy).



**HT to RT DS1 test results**

HT location: \_\_\_\_\_

Test successful?  Yes  No RSSI \_\_\_\_\_

If not successful, complete:

Bit error rate \_\_\_\_\_ Frame slips \_\_\_\_\_

Frame errors \_\_\_\_\_ Clock slips \_\_\_\_\_

Trouble report generated?  Yes  No

If yes, report number: \_\_\_\_\_

If applicable: Faulty module part number \_\_\_\_\_

Serial number \_\_\_\_\_

If applicable: Replacement board part number \_\_\_\_\_

Serial number \_\_\_\_\_

BER test printout attached?  Yes  No

Comments:

\_\_\_\_\_  
\_\_\_\_\_

Tested by (print name and sign): \_\_\_\_\_

Customer (print name and sign): \_\_\_\_\_

Date \_\_\_\_\_

**DS3 test** This test verifies the DS3 connection from the HT to the RT.

**Requirements**

The DS3 test described below requires the following:

- The HT must be operational and in contact with the EMS.
- The RT must be fully installed, commissioned, and in contact with the EMS through the hub.
- DS3 services must be configured and provisioned.
- There must be no alarms present at the RT location.
- A loopback connector must be connected to the input/output port connector of the RT Universal DS1 SSI used for the test. (See figure 7-1.)

**Test procedure**

1. Connect a DS3 test set to the out/input points at the patch panel.
2. Select:
  - C bit framing
  - Recovered clock
  - DS3 interface

DS1 services may be dropped from the DS3 data stream and tested using QRSS test patten.

The DS3 test set and HT may be timed from the same source.

3. Run the test for 1 hour.

**Results**

The HT passes if there are no errors and no clock or frame slips during the test.

Record the results on the form on the following page (or make a photocopy).

**HT to RT DS3 test results**

HT location: \_\_\_\_\_

Test successful?  Yes  No RSSI \_\_\_\_\_

If not successful, complete:

Bit error rate \_\_\_\_\_ Frame slips \_\_\_\_\_

Frame errors \_\_\_\_\_ Clock slips \_\_\_\_\_

Trouble report generated?  Yes  No

If yes, report number: \_\_\_\_\_

If applicable: Faulty module part number \_\_\_\_\_

Serial number \_\_\_\_\_

If applicable: Replacement board part number \_\_\_\_\_

Serial number \_\_\_\_\_

BER test printout attached?  Yes  No

Comments:

\_\_\_\_\_  
\_\_\_\_\_

Tested by (print name and sign): \_\_\_\_\_

Customer (print name and sign): \_\_\_\_\_

Date \_\_\_\_\_

## **Fractional DS1 test**

This test verifies the fractional DS1 connection from the HT to the RT.

### **Requirements**

The fractional DS1 test described below requires the following:

- The HT must be operational and in contact with the EMS.
- The RT must be fully installed, commissioned, and in contact with the EMS through the hub.
- DS3/DS1, fractional DS0 services must be configured and provisioned.
- There must be no alarms present at the RT location.
- A loopback connector must be connected to the input/output port connector on the RT DS1 SSI used for the test. (See figure 7-1.)

### **Test procedure**

1. Connect a DS3 test set to the out/input points at the patch panel.
2. Select:
  - C bit framing
  - Recovered clock
  - DS3 interface
  - QRSS test patten

The fractional DS1 services may be dropped and tested after connecting a DS1/DS0 test set to the input/output ports of the DS3 test set.

The DS3 test set and HT may be timed from the same source.

3. Run the test for 1 hour.

### **Results**

The HT passes if there are no errors and no clock or frame slips during the test.

Record the results on the form on the following page (or make a photocopy).

**HT to RT fractional DS1 test results**

HT location: \_\_\_\_\_

Number of DS0s tested \_\_\_\_\_

Test successful?  Yes  No RSSI \_\_\_\_\_

If not successful, complete:

Bit error rate \_\_\_\_\_ Frame slips \_\_\_\_\_

Frame errors \_\_\_\_\_ Clock slips \_\_\_\_\_

Trouble report generated?  Yes  No

If yes, report number: \_\_\_\_\_

If applicable: Faulty module part number \_\_\_\_\_

Serial number \_\_\_\_\_

If applicable: Replacement board part number \_\_\_\_\_

Serial number \_\_\_\_\_

BER test printout attached?  Yes  No

Comments:

\_\_\_\_\_  
\_\_\_\_\_

Tested by (print name and sign): \_\_\_\_\_

Customer (print name and sign): \_\_\_\_\_

Date \_\_\_\_\_

## **Fractional DS3 test**

This test verifies the fractional DS3 connection from the HT to the RT.

### **Requirements**

The fractional DS3 test described below requires the following:

- The HT must be operational and in contact with the EMS.
- The RT must be fully installed, commissioned, and in contact with the EMS through the hub.
- Fractional DS3 services must be configured and provisioned.
- There must be no alarms present at the RT location.
- A loopback connector must be connected to the input/output port of the RT DS3 SSI used for the test. (See figure 7-1.)

### **Test procedure**

1. Connect a DS3 test set to the out/input points at the patch panel.
2. Select:
  - C bit framing
  - Recovered clock
  - DS3 interface

Fractional DS1 services may be dropped from the DS3 data stream and tested using QRSS test pattern.

The DS3 test set and HT may be timed from the same source.

3. Run the test for 1 hour.

### **Results**

The HT passes if there are no errors and no clock or frame slips during the test.

Record the results on the form on the following page (or make a photocopy).

**HT to RT fractional DS3 test results**

HT location: \_\_\_\_\_

Number of DS1s tested \_\_\_\_\_

Test successful?  Yes  No RSSI \_\_\_\_\_

If not successful, complete:

Bit error rate \_\_\_\_\_ Frame slips \_\_\_\_\_

Frame errors \_\_\_\_\_ Clock slips \_\_\_\_\_

Trouble report generated?  Yes  No

If yes, report number: \_\_\_\_\_

If applicable: Faulty module part number \_\_\_\_\_

Serial number \_\_\_\_\_

If applicable: Replacement board part number \_\_\_\_\_

Serial number \_\_\_\_\_

BER test printout attached?  Yes  No

Comments:

\_\_\_\_\_  
\_\_\_\_\_

Tested by (print name and sign): \_\_\_\_\_

Customer (print name and sign): \_\_\_\_\_

Date \_\_\_\_\_

## Chapter 8

# Final steps

---

This chapter describes the final steps you take before leaving the customer site after completing the installation:

- Weatherproofing – page 8–2
- Inspection, cleanup, and customer sign-off – page 8–3
- Connecting customer equipment – page 8–3

### Safety warnings

Observe these safety warnings while performing final inspections and related tasks:



#### DANGER

Do not work on a ladder or roof without first reading the safety warnings on page x of this manual. Failure to observe these warnings could result in personal injury or death.

---



#### WARNING

Potential radio frequency (RF) hazard:

- Keep away from the front of the outdoor unit (ODU) antenna while the ODU is operating. Note that you cannot tell from outward appearance whether the ODU is operating or not.
- Be careful with respect to the ODU you are installing and ODUs that may already be operating in the installation area.

Failure to observe these warnings could result in injury to eyes or other personal injury.

---



## Weatherproofing

After the HT has been successfully commissioned, seal all outdoor IFL connections (including connections to the lightning arrester assembly) with electrical tape and weatherproofing compound to protect against moisture penetration:

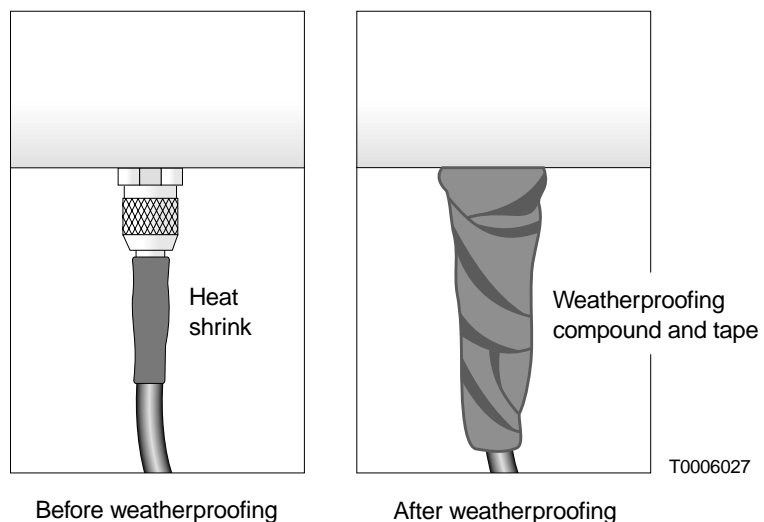
See figure 8-1.

1. Starting at the connector end, wrap electrical tape around the connector and part of the cable.
  2. Cover the electrical tape with weatherproofing compound, and work the compound into all joints and cracks where water could enter.
  3. Smooth the weatherproofing compound, giving the connection a tapered appearance, as shown in figure 8-1.
  4. Again starting at the connector end, wrap a second layer of electrical tape around (on top of) the weatherproofing compound.
  5. Press the tape into the weatherproofing compound.
- The resulting seal should be tight and compact, with no loose tape ends.



### CAUTION

Outdoor connectors are subject to moisture contamination. Even minute amounts of water vapor can condense and cause a short circuit. Thoroughly seal all outdoor IFL connections with weatherproofing compound.



**Figure 8-1** Applying weatherproofing compound and tape

## 8.2

---

### **Inspection, cleanup, and sign-off**

After all equipment is installed and commissioned, visit each installation area to inspect the equipment and make sure the area is left clean and orderly.

#### **Inspection**

Inspect all equipment to make sure:

- All cables are dressed (as necessary) and not bent excessively.
- All connections are secure.
- IFL connections and entry panels are properly waterproofed.
- IDUs, racks, and ODUs are properly grounded.
- Antenna mount bolts are tightened.
- ODU adjusters and the temporary installation collar have been removed for future use.

#### **Cleanup**

Clean up all installation areas:

- Make sure no tools or other objects are left on or near the equipment.
- Remove or neatly store any excess materials.
- Remove all debris.

#### **Customer sign-off**

Before leaving the site, notify the appropriate customer representative that the work has been completed. Ask the representative to sign the work order, indicating that the equipment has been installed and has passed the initial loopback verification test(s).

## 8.3

---

### **Connecting customer equipment**

The customer is responsible for connecting customer equipment to the AIReach Broadband equipment through connections to service-specific interface (SSI) modules. Refer to section 6.5 for information on the services and specific interfaces provided by each SSI type.

This chapter includes:

- Troubleshooting flow charts – page 9–1
- Service information – page 9–6

### 9.1

---

#### Troubleshooting flow charts

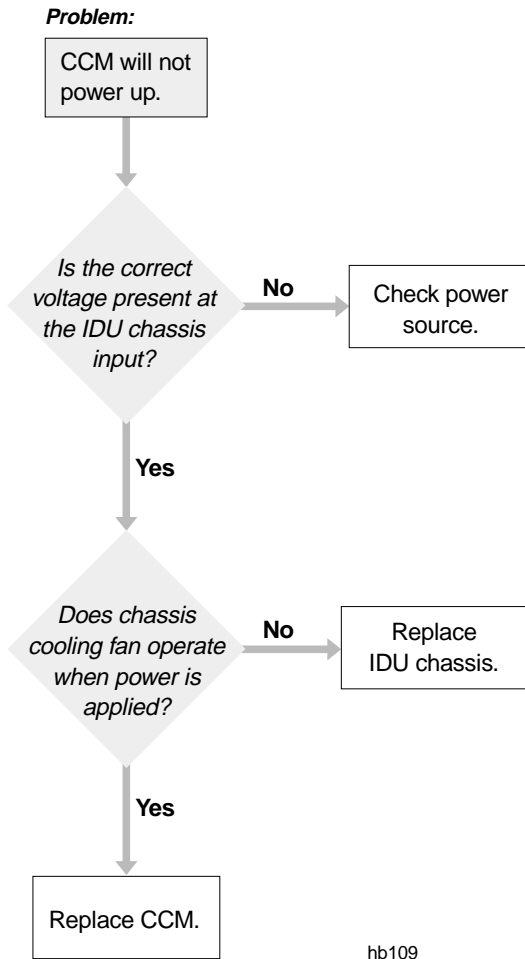
The troubleshooting flow charts in this chapter will help isolate most problems you might encounter during installation and operation of the AIReach Broadband system.

Each flow chart begins with a specific problem, then leads you to specific corrective actions you should take. **Where actions are numbered in these charts, you may not need to perform all of the actions.** Perform the actions in order, and check after each action to see if the problem has been resolved. **Proceed to the next action only if the previous action did not correct the problem.**

The information in this chapter is intended for use by technicians experienced in electronics troubleshooting. Therefore, it suggests corrective actions but does not include detailed instructions for each action.

## Troubleshooting the CCM

---



## Troubleshooting the CCM - *Continued*

---

**Problem:**

CCM failed startup diagnostics (SUDS).



Replace CCM.

**Problem:**

During CCM bootup / hardware initialization, LCD displays any of the following messages, indicating a device failure:

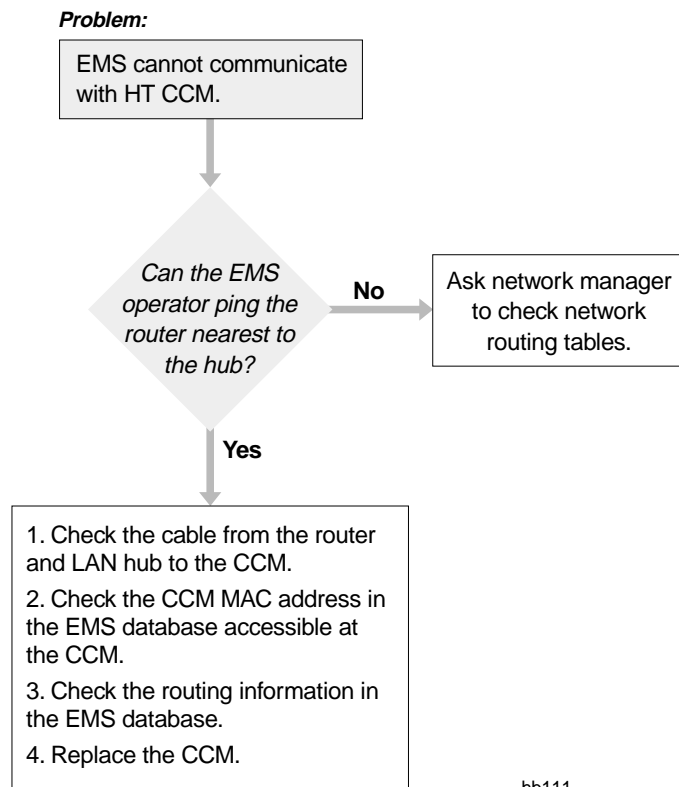
- Host Cfg Failed
- PLX Failed
- PLX IO Failed
- LAN Failed
- RCC FPGA Failed
- BSB FPGA Failed
- QPIG FPGA Failed
- Tim syn Failed



Replace CCM.

hb110

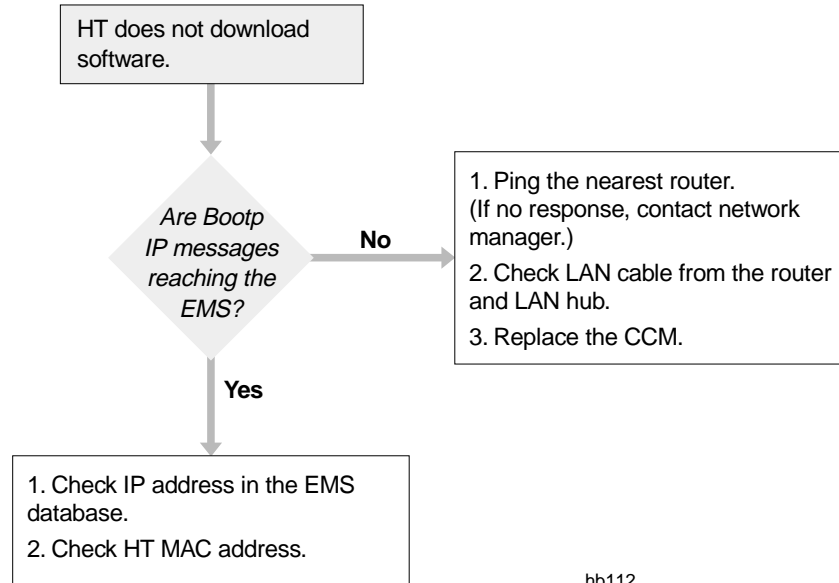
## Troubleshooting the hub site LAN connection



## Hub site LAN connection - *Continued*

---

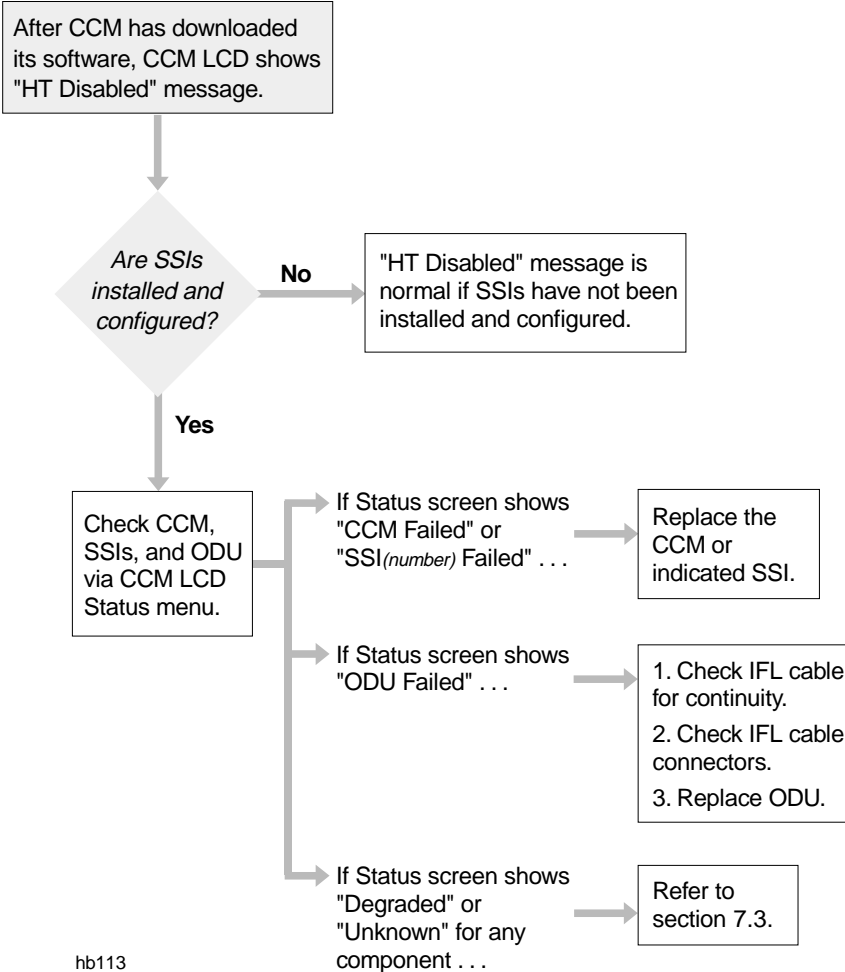
**Problem:**



hb112

## Troubleshooting: "HT Disabled"

**Problem:**



hb113

## 9.2

### Additional troubleshooting information

**IDU chassis fan doesn't work.** If the chassis is a dc powered unit, make sure the polarity of the wires to the power supply is not reversed.

## 9.3

### Repair or replacement service

If you find a faulty component, contact your contract administrator to arrange for repair or replacement.



The AIReach Broadband physical system requires no routine maintenance. However, to facilitate expansion, reconfiguration, or repairs, you may need to add, move, or replace components. This chapter includes instructions for:

- Adding or moving SSIs – page 10–2
- Replacing components – page 10–3
- Replacing the ODU – page 10–3
- Replacing the IDU chassis – page 10–8
- Replacing the CCM – page 10–10
- Replacing SSIs – page 10–11
- Replacing the IFL – page 10–12
- Dismantling an HT – page 10–14

---

## Adding or moving SSIs

**Notify the EMS operator before you add or move SSIs.** Make sure the EMS operator has performed any prerequisite steps that may be necessary before you add or move an SSI.

*For instructions on replacing SSIs, see section 10.6.*



### CAUTION

**Always wear a new or recently tested electrostatic discharge (ESD) wrist strap (figure 6-16) when handling circuit modules. Failure to use a wrist strap may result in damage to components.**

---

### Adding SSIs

You can install additional SSIs while the system is powered on. To add an SSI, follow the instructions in section 6.5 (page 6–28).

After installing an SSI, use the CCM LCD Status function to check its operational status. The LCD should display OK. (For an explanation of the CCM LCD Status function, see section 7.3.)

### Moving SSIs

SSIs are hot-swappable, meaning you can move them from one slot to another or to another chassis while the chassis are powered on.

**Important: Install the OC3c–ATM SSI in chassis slot 3 only, and install the DS3–TDM SSI in slot 5 only.**

To move an SSI:

1. Loosen the thumbscrews at each end of the SSI.
2. Using an ESD wrist strap connected to a chassis ground terminal, slide the SSI out of its slot.
3. Move the SSI to its new location and insert it into the slot.
4. Tighten the thumbscrews at each end of the SSI.
5. Use the CCM LCD to check the SSI status. (For details, see section 7.3).

## 10.2

---

### Replacing components

The following HT components can be replaced at the installation site if a problem is attributed to the component:

- ODU
- IDU chassis
- CCM
- SSIs
- IFL

Specific instructions for replacing each component follow, in sections 10.3 through 10.7.

## 10.3

---

### Replacing the ODU

If the ODU is faulty, you normally replace the transceiver only (which contains the ODU electronics). Replace the antenna only if it is physically damaged (for example, wind or water damage) or has some other known problem.



#### **DANGER**

**Do not work on a ladder or roof without first reading the safety warnings on page x of this manual. Failure to observe these warnings could result in personal injury or death.**

---



#### **WARNING**

**Potential radio frequency (RF) hazard:**

- **Keep away from the front of the outdoor unit (ODU) antenna while the ODU is operating. Note that you cannot tell from outward appearance whether the ODU is operating or not.**
- **Be careful with respect to the ODU you are installing and ODUs that may already be operating in the installation area.**

**Failure to observe these warnings could result in injury to eyes or other personal injury.**

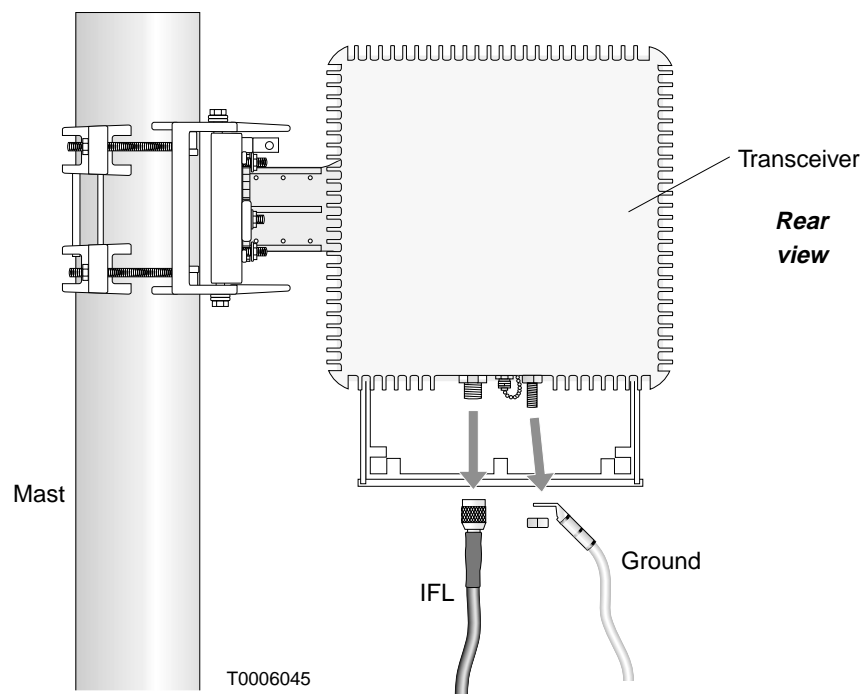
---

## Replacing the transceiver

To replace the transceiver, follow these steps:

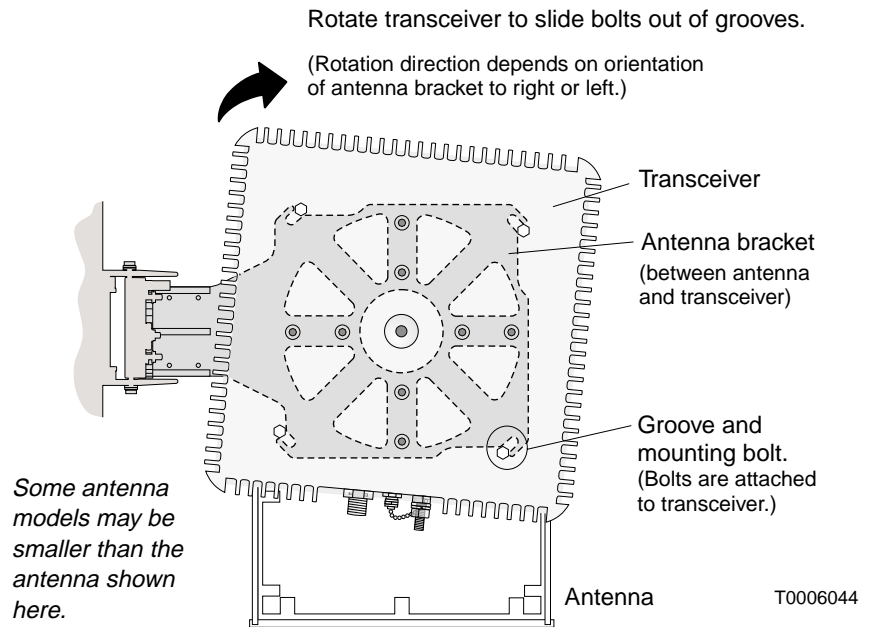
### **Removing the existing transceiver**

1. **Make sure the EMS operator has taken the HT out of service.**
2. **At the IDU location: Remove power from the IDU chassis power supply.**
3. **On the roof: Disconnect the ground cable and IFL from the ODU transceiver, as shown in figure 10-1.**



**Figure 10-1** Disconnecting the ODU ground and IFL cables

4. Loosen the four transceiver mounting bolts (shown in figure 10-2).



**Figure 10-2 Removing the transceiver**

5. Rotate the transceiver until the bolts slide out of the four grooves in the antenna bracket. (The direction of rotation depends on the orientation of the antenna bracket—to the right or left.) If the mounting bolts will not slide into the grooves, loosen the bolts. See figure 10-2.



**CAUTION**

**Do not allow dirt, dirt, moisture, or other contaminants to enter the waveguide.**

6. Cover the transceiver coupling (center hole) with a plastic coupling plug (if available) or tape to prevent contamination.

***Installing the replacement transceiver***

7. To install the replacement transceiver, follow the steps in section 4.10 (page 4–23).
8. Connect the IFL cable to the IFL connector on the transceiver.
9. Ground the ODU, as explained in section 4.11 (page 4–25).

10. After you replace the transceiver:
  - Go to the next subsection (*Replacing the antenna*) only if you need to replace the antenna.
  - Apply power to the IDU chassis power supply.
  - Use the CCM LCD to check the ODU status. (For details, see section 7.3).
  - Notify the EMS operator that the HT is ready to resume service.

If you are replacing the transceiver only, you should not need to realign the antenna.

## Replacing the antenna

If you need to replace the antenna, follow these steps:

### **Removing the existing antenna**

1. Remove the transceiver (steps 1 through 6 above, beginning on page 10–4). **Be sure to remove power from the IDU chassis power supply.**

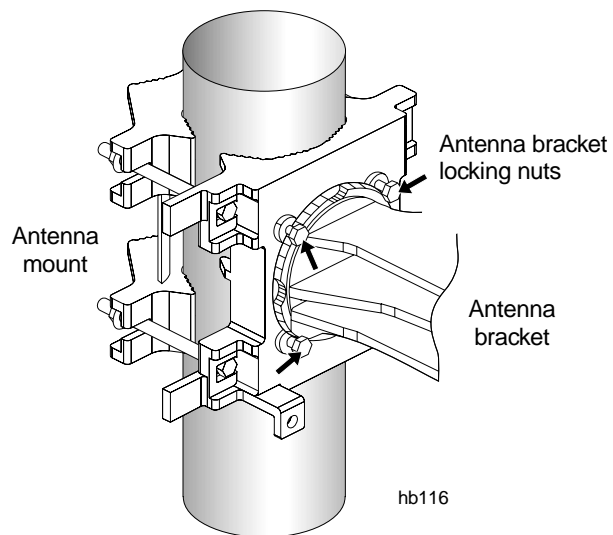


### **CAUTION**

**Do not allow dirt, dirt, moisture, or other contaminants to enter the waveguide.**

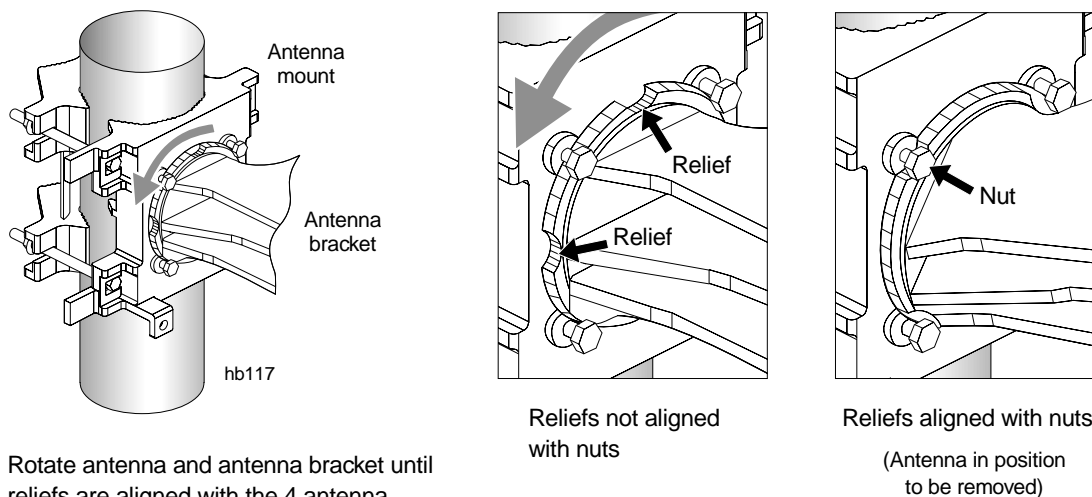
---

2. Loosen the four antenna bracket locking nuts.



**Figure 10-3 Antenna bracket locking nuts**

3. Rotate the antenna (clockwise or counterclockwise) until the antenna bracket reliefs (curved indentations) are aligned with the four nuts on the mast interface, as shown in figure 10-4.



**Figure 10-4 Removing the antenna**

4. Move the antenna away from the mast interface.
5. Cover the antenna waveguide (center hole) with a plastic plug or tape to protect against contamination.

#### ***Installing the replacement antenna***

6. Attach the replacement antenna to the mount, as explained in section 4.6 (page 4–15).
7. Align the replacement antenna by adjusting the azimuth and elevation as detailed in sections 4.7 and 4.8 (beginning on page 4–18).
8. Attach the transceiver to the antenna, as explained in section 4.10 (page 4–23).
9. Connect the IFL cable to the IFL connector on the transceiver.
10. Ground the ODU, as explained in section 4.11 (page 4–25).
11. Apply power to the IDU chassis power supply (section 6.3, page 6–11).
12. Use the CCM LCD to check the ODU status. (For details, see section 7.3).
13. Notify the EMS operator that the HT is ready to resume service.

## Replacing the IDU chassis

Do not attempt to service or replace the IDU chassis power supply. **If there is a problem with the power supply, replace the entire IDU chassis.**

To replace the IDU chassis, follow these steps:

*If you need additional details concerning the instructions below, see chapter 6.*

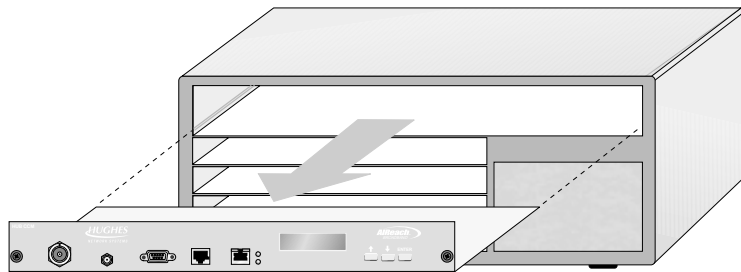
### Removing the existing IDU chassis

1. **Make sure the EMS operator has taken the HT out of service.**
2. **Remove power from the IDU chassis power supply.**
3. Mark each cable or otherwise note where each cable is connected.
4. Remove all cables from all modules.
5. Remove the CCM:
  - a. Loosen the thumbscrews at each end.
  - b. Using an ESD wrist strap connected to a chassis ground terminal, slide the CCM out of its slot, as shown in figure 10-5.



### CAUTION

Always wear a new or recently tested electrostatic discharge (ESD) wrist strap (figure 6-16) when handling circuit modules. Failure to use a wrist strap may result in damage to components.



hb118

Figure 10-5 Removing the CCM



6. Place the CCM in its ESD protective packaging.
7. Remove all SSIs:
  - a. Using a piece of tape on the SSI front panel, mark the slot number where each SSI was installed.
  - b. Loosen the thumbscrews at each end.
  - c. Using an ESD wrist strap connected to a chassis ground terminal, slide the SSI out of its slot.
8. Place each SSI in ESD protective packaging.
9. If the IDU chassis is rack mounted, remove the four mounting screws and remove the chassis from the rack.
10. Remove the rack mounting brackets from the chassis.

### ***Installing the replacement IDU chassis***

Refer to the instructions in chapter 6 to:

11. Install the replacement chassis in a rack, if the original chassis was installed in a rack (section 6.2).
12. Re-connect power to the IDU chassis power supply (section 6.3).
13. Conduct a power-on test (section 6.3).
14. Re-install the CCM (section 6.4).
15. Re-install the SSIs (section 6.5).  
Install each SSI in the slot it was in before. Refer to the slot numbers you marked on the tape on each SSI.
16. Re-connect the IFL cable and all other cables to the CCM and SSIs.

## Replacing the CCM

If you need to replace the CCM, follow these steps:

*If you need additional details concerning the instructions below, see section 6.4 (page 6–26).*

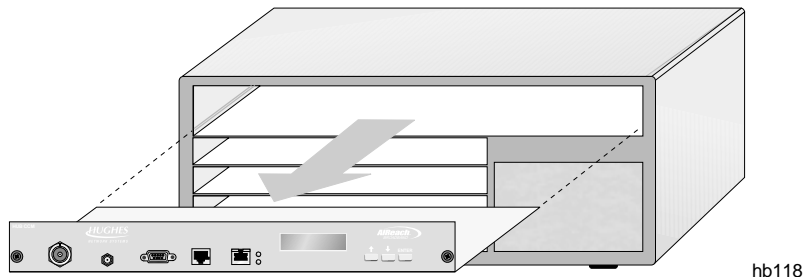
### Removing the existing CCM

1. **Make sure the EMS operator has taken the HT out of service.**
2. **Remove power from the IDU chassis power supply.**
3. Loosen the thumbscrews at each end of the (existing) CCM.
4. Using an ESD wrist strap connected to a chassis ground terminal, slide the CCM out of its slot, as shown in figure 10-6.



### CAUTION

Always wear a new or recently tested electrostatic discharge (ESD) wrist strap (figure 6-16) when handling circuit modules. Failure to use a wrist strap may result in damage to components.



hb118

**Figure 10-6 Removing the CCM**

5. Place the CCM in ESD protective packaging.

### Installing the replacement CCM

6. Slide the replacement CCM into the CCM slot (slot 1).
7. Tighten the thumbscrews at each end of the CCM.
8. Apply power to the IDU chassis power supply.
9. Use the CCM LCD to check the CCM status. (For details, see section 7.3).
10. Notify the EMS operator that the HT is ready to resume service.

---

## Replacing SSIs

To replace an SSI, follow the steps below.

SSIs are hot swappable, so you do not need to power off the IDU to replace an SSI. *If you need additional details concerning the instructions below, see section 6.5 (page 6–28).*

### **Removing the SSI**

1. Note which slot the SSI to be replaced is in.
2. Loosen the thumbscrews at each end of the SSI.
3. Using an ESD wrist strap connected to a chassis ground terminal, slide the SSI out of its slot.



### **CAUTION**

Always wear a new or recently tested electrostatic discharge (ESD) wrist strap (figure 6-16) when handling circuit modules. Failure to use a wrist strap may result in damage to components.

---

4. Place the SSI in ESD protective packaging.

### **Installing the replacement SSI**

5. Slide the replacement SSI into the slot from which you removed the previously installed SSI.
6. Tighten the thumbscrews at each end of the SSI.
7. Use the CCM LCD to check the SSI status. (For details, see section 7.3).
8. Notify the EMS operator that the replacement SSI is ready for service.

---

## Replacing the IFL

If you suspect problems with the IFL, check all IFL connections and then test the IFL. Replace the IFL only if there is a known problem that cannot be corrected any other way.



### DANGER

Do not work on a ladder or roof without first reading the safety warnings on page x of this manual. Failure to observe these warnings could result in personal injury or death.

---



### WARNING

Potential radio frequency (RF) hazard:

- Keep away from the front of the outdoor unit (ODU) antenna while the ODU is operating. Note that you cannot tell from outward appearance whether the ODU is operating or not.
- Be careful with respect to the ODU you are installing and ODUs that may already be operating in the installation area.

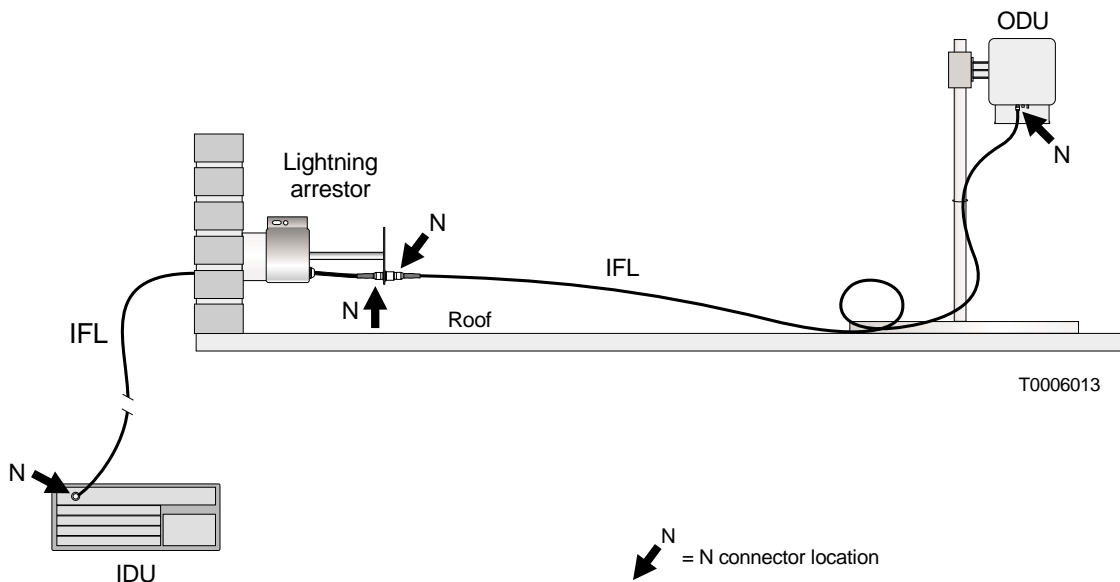
Failure to observe these warnings could result in injury to eyes or other personal injury.

---

Environments where IFLs are installed vary widely. Therefore, use the general instructions below as guidelines.

If you need to replace the IFL:

1. **Make sure the EMS operator has taken the HT out of service.**
2. **Remove power from the IDU chassis power supply.**
3. Disconnect all four IFL N connectors, as shown in figure 10-7:
  - 1 connector at the IDU
  - 1 connector at the ODU
  - 2 connectors at the lightning arrester



**Figure 10-7 Disconnect N connectors at the four locations shown here**

4. Remove the two IFL cable segments:
  - From IDU to the lightning arrester
  - From the lightning arrester to the ODU
5. Install the replacement IFL cable according to the instructions in chapter 5.

---

## Dismantling an HT

If you need to dismantle an entire HT, follow the steps below.

---



### DANGER

Do not work on a ladder or roof without first reading the safety warnings on page x of this manual. Failure to observe these warnings could result in personal injury or death.

---



### WARNING

Potential radio frequency (RF) hazard:

- Keep away from the front of the outdoor unit (ODU) antenna while the ODU is operating. Note that you cannot tell from outward appearance whether the ODU is operating or not.
- Be careful with respect to the ODU you are installing and ODUs that may already be operating in the installation area.

Failure to observe these warnings could result in injury to eyes or other personal injury.

---

Follow these steps:

1. **Make sure the EMS operator has taken the HT out of service.**
2. **Remove power from the IDU chassis power supply.**
3. *On the roof:* Disconnect the IFL and ground cable from the ODU. See section 10.3.
4. Remove the transceiver. See section 10.3.
5. Remove the antenna. See section 10.3.
6. Disassemble the mast and mast mount.
7. *At the IDU location:* Remove all cables from all modules. If the cables will be reused, mark them to identify them.
8. *Optional:* Remove the CCM and SSIs from the chassis. (Depending on what you will do with the equipment, you might want to leave the CCM and SSIs installed.) See sections 10.5 and 10.6.
9. Remove the IDU chassis.
10. Remove the IFL cable and lightning arrester (unless the lightning arrester is being used for other HTs or will be reused).

# Acronyms and abbreviations

---

**ac** – alternating current

**ATM** – asynchronous transfer mode

**AWG** – American wire gauge

**BER** – bit error rate

**BSP** – baseband signal processor

**C** – Celsius

**CCM** – channel and control module

**cm** – centimeter

**CMR** – communication riser

**CPU** – central processing unit

**dc** – direct current

**DRAM** – dynamic RAM

**EIDU** – expansion indoor unit

**EMS** – Element Management System

**ESD** – electrostatic discharge

**ESN** – electronic serial number

**F** – Fahrenheit

**FCC** – Federal Communications Commission

**FRAD** – frame relay access device

**ft** – foot

**HNS** – Hughes Network Systems

**HT** – hub terminal

**Hz** – hertz

**ID** – identification

**IDU** – indoor unit

**IEC** – International Electrotechnical Commission

**IF** – intermediate frequency

**IFL** – intrafacility link

**in.** – inch

**IP** – Internet protocol

**LAN** – local area network

**lb** – pound(s)

**LCD** – liquid crystal display

**LED** – light emitting diode

**LOS** – line of sight

**m** – meter

**MAC** – media access control

**mm** – millimeter

**NEBS** – Network Equipment Building Standards

**NEC** – National Electric Code

**NEMA** – National Electrical Manufacturing Association

**NFPA** – National Fire Protection Association

**ODU** – outdoor unit

**OSPF** – open shortest path first

**PC** – personal computer

**PCI** – PC interface

**PMP** – point-to-multipoint

**QRSS** – quasi random signal source

**RAM** – random-access memory

**RF** – radio frequency

**ROM** – read-only memory

**RT** – remote terminal

**SDRAM** – static dual port RAM

**SSI** – service-specific interface

**SUDS** – startup diagnostics

**TAC** – Technical Assistance Center

**TDM** – time division multiplexing

**UL** – Underwriters Laboratories

**V** – volt

**Vac** – volt, alternating current

**Vdc** – volt, direct current

**VSAT** – very small aperture terminal

**WND** – Wireless Networks Division

**WDT** – watch dog timer



# **Standards compliance**

---

This appendix includes standards compliance information for the AIReach Broadband outdoor unit (ODU) and ac power indoor unit (IDU). Information is included for:

- Interference standards compliance
- Underwriters Laboratories, Inc., safety compliance
- RF, electrical fast transient, and ESD immunity

**Outdoor unit**

This section provides information on the AIReach Broadband **outdoor unit (ODU)**.

**FCC compliance**

This equipment complies with Part 15 of United States Federal Communication Commission (FCC) Rules. Operation is subject to the following two conditions: (1) This device may not cause harmful interference, and (2) this device must accept any interference received, including interference that may cause undesired operation.

This equipment has been tested and found to comply with the limits for a **Class A digital device**, pursuant to Part 15 of FCC Rules. These limits are designed to provide reasonable protection against harmful interference when the equipment is operated in a commercial environment.

This equipment generates, uses, and can radiate radio frequency energy and, if not installed and used in accordance with this instruction manual, may cause harmful interference to radio communications. Operation of this equipment in a residential area is likely to cause interference, in which case the user will be required to correct the interference at the user's own expense.

Type acceptance: FCC Part 101

**Canadian interference compliance**

This class A digital apparatus meets all requirements of the Canadian Interference–Causing Equipment Regulations.

Cet appareil numérique de la Classe A respecte toutes les exigences du Règlement sur le matériel brouilleur du Canada.

**Underwriters Laboratories (UL)**

This equipment has been evaluated by Underwriters Laboratories Inc. (UL) and determined to be in compliance with the Standard for Safety of Information Technology Equipment Including Electrical Business Equipment, **UL 1950**, third edition; and Canadian Standards Association **CAN/CSA C22.2 No. 950–95**, third edition. This equipment is UL listed and UL certified for Canada as Information Technology Equipment.

**National Electric Code (NEC)**

The ODU complies with requirements of the National Electric Code (NEC), article 800.

**Emissions**

The ODU complies with EN 55022.

---

**Indoor unit (ac)**

This section provides information on the AIReach Broadband **ac power indoor unit (IDU)**.

**FCC compliance**

This equipment complies with Part 15 of United States Federal Communication Commission (FCC) Rules. Operation is subject to the following two conditions: (1) This device may not cause harmful interference, and (2) this device must accept any interference received, including interference that may cause undesired operation.

This equipment has been tested and found to comply with the limits for a **Class A digital device**, pursuant to Part 15 of FCC Rules. These limits are designed to provide reasonable protection against harmful interference when the equipment is operated in a commercial environment.

This equipment generates, uses, and can radiate radio frequency energy and, if not installed and used in accordance with this instruction manual, may cause harmful interference to radio communications. Operation of this equipment in a residential area is likely to cause interference, in which case the user will be required to correct the interference at the user's own expense.

**Canadian interference compliance**

This class A digital apparatus meets all requirements of the Canadian Interference-Causing Equipment Regulations.

Cet appareil numérique de la Classe A respecte toutes les exigences du Règlement sur le matériel brouilleur du Canada.

**Underwriters Laboratories (UL)**

This equipment has been evaluated by Underwriters Laboratories Inc. (UL) and determined to be in compliance with the Standard for Safety of Information Technology Equipment Including Electrical Business Equipment, **UL 1950**, third edition; and Canadian Standards Association **CAN/CSA C22.2 No. 950-95**, third edition. This equipment is UL listed and UL certified for Canada as Information Technology Equipment.

**Immunity**

The ODU complies with the following immunity standards of the International Electrotechnical Commission (IEC):

- Radio frequency immunity – IEC 801-3 (3 V/m)
- Electrical fast transient immunity – IEC 801-4
- Electrostatic discharge immunity – 25 KV level tested using method in IEC 801-2

**Emissions**

The ODU complies with EN 55022.

## Appendix C

# Terminating IFL cables

---

This appendix explains in detail how to terminate the IFL cable ends by attaching an N-type connector. It includes:

- Cable parts and terminology – page C-2
- Preparing the cable end – page C-3
- Attaching the connector – page C-6
- Applying heat-shrink tubing – page C-11

As part of the RT installation, you attach N connectors in four locations, as shown in figure 5-1 (on page 5-3):

- One N connector at the IDU location
- Two N connectors to connect to the lightning arrester assembly
- One N connector at the ODU location

**Important:** Sound IFL cable connections are critical for proper operation of the AIReach Broadband system.

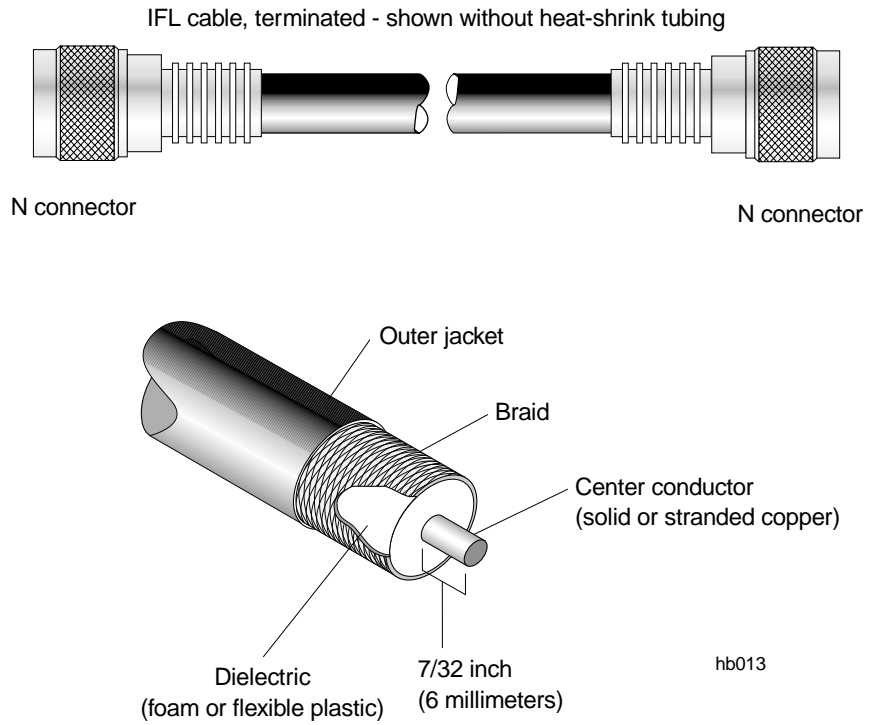
Therefore, be very careful in terminating the cable. If you are unsure about the success of any of the following steps, repeat them.

**Attach N connectors *after* you route and install the cable, not before.**

**Note:** The instructions below are for the connectors in HNS kit 9006284-0002. If you use a different N-type connector, follow the manufacturer's instructions.

## Cable parts and terminology

Figure C-1 shows the main cable components.



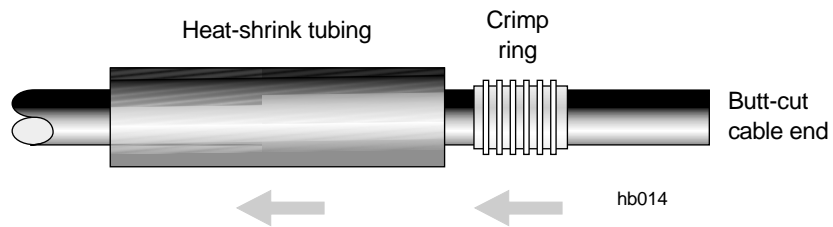
**Figure C-1 IFL cable components**

HNS kit 9006284-0002 contains two N connectors.

## Preparing the cable end

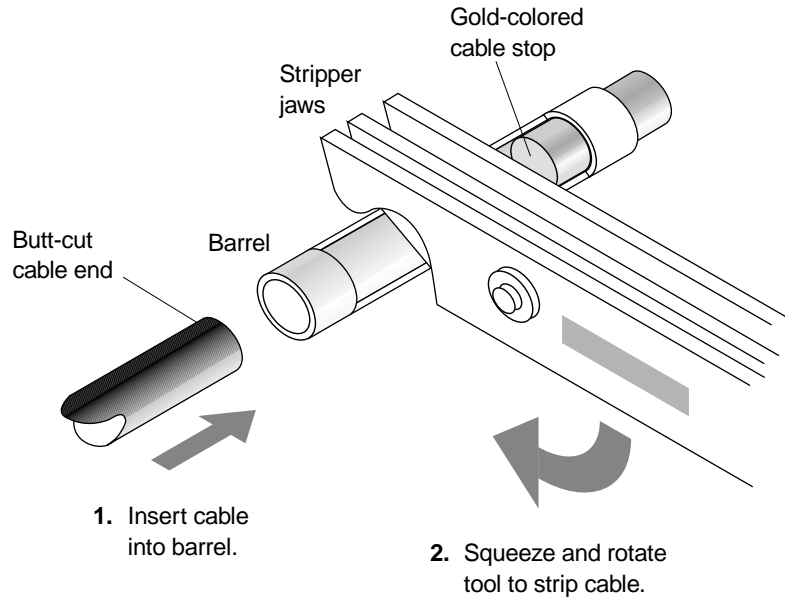
Prepare the cable end as follows:

1. Inspect the cable end for damage from handling and trim off any damaged portions.
2. Cut the cable as cleanly and squarely as possible.
3. Slip the crimp ring and a piece of heat-shrink tubing (HNS9007488-0005) onto the cable, as shown in figure C-2.



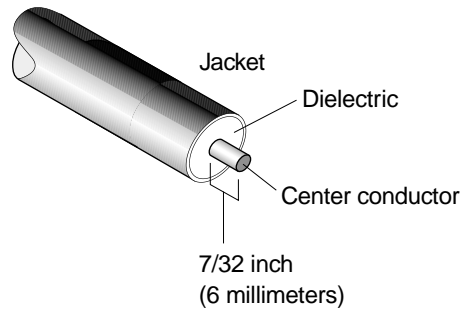
**Figure C-2 Slipping the crimp ring and heat-shrink tubing onto the cable**

4. Use the spin-stripping tool (Excelta CX 1-78-1, gold color-coded) to remove the cable jacket and dielectric, leaving about 7/32 inch (6 millimeters) of the center conductor exposed, as shown in figure C-3.
  - a. Open the stripping jaws of the spin-stripping tool enough to allow the cable end to enter the cable barrel fully. (See figure C-3.)
  - b. While holding the cable firmly in the tool and tightly against the cable stop, squeeze the stripper jaws.
  - c. Rotate the tool around the cable two or three times until the outer cable jacket and dielectric are completely cut through, but *do not score the center conductor*. Rotate the tool in the direction indicated in figure C-3.
  - d. Remove the cut-off end of the cable jacket and dielectric.



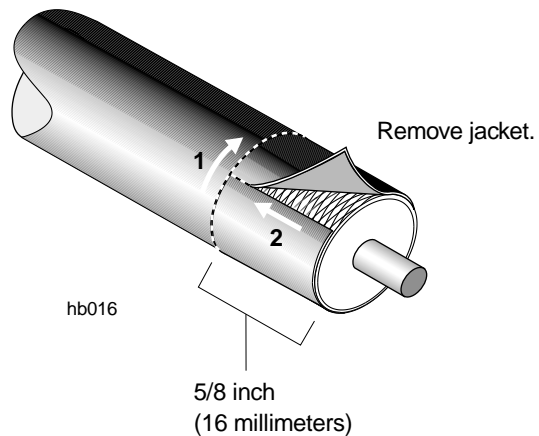
3. Remove jacket and dielectric to expose center conductor.

hb012



**Figure C-3 Using the spin-stripping tool to expose the center conductor**

5. Using a razor knife, *carefully* slit the outer jacket as shown in figure C-4.  
Cut around the cable; then cut from the cable end to the first cut. Cut completely through the jacket, *but do not cut into the braid*.
6. Using the razor knife or a pair of diagonal cutters, lift the jacket and peel it away as shown in figure C-4.



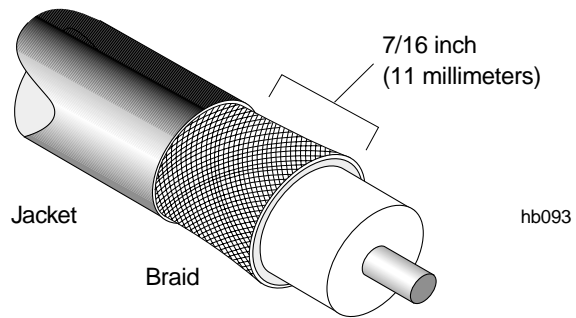
**Figure C-4 Cutting and removing the jacket**

7. Check:
  - Braid for nicked or broken strands
  - Dielectric end for a straight cut
  - Center conductor for nicks and a straight cut

**If you see significant damage to the braid, dielectric, or conductor, you must cut the cable and start over. (Start with step 1.)**



8. Flare the braid *slightly* and trim to 7/16 inch (11 millimeters), as shown in figure C-5.



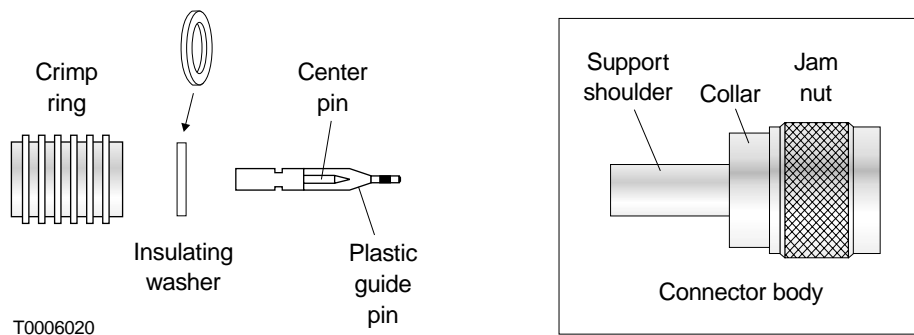
**Figure C-5 Braid, flared and trimmed**

9. Cut approximately 1/4 inch (6 millimeters) of the excess braid so that all braids will be under the crimp ring when the connector is completed.

### C.3

## Attaching the connector

The following steps explain how to attach the IFL (N) connector. The same type of connector is used at both ends. The connector includes a plastic guide pin to protect the dielectric during installation, as shown in figure C-6.



**Figure C-6 IFL (N) connector (HNS 9006284-0002)**

**Do not remove the plastic guide pin until instructed to do so** (step 4 on page C-8).

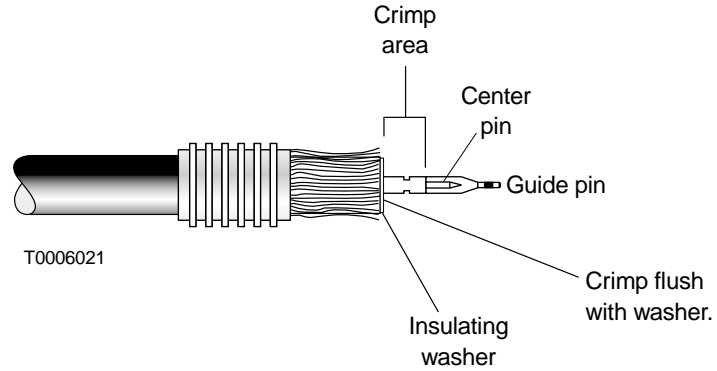


### CAUTION

**Do not install the center pin without the plastic guide pin—doing so will damage the dielectric material inside the connector body.**

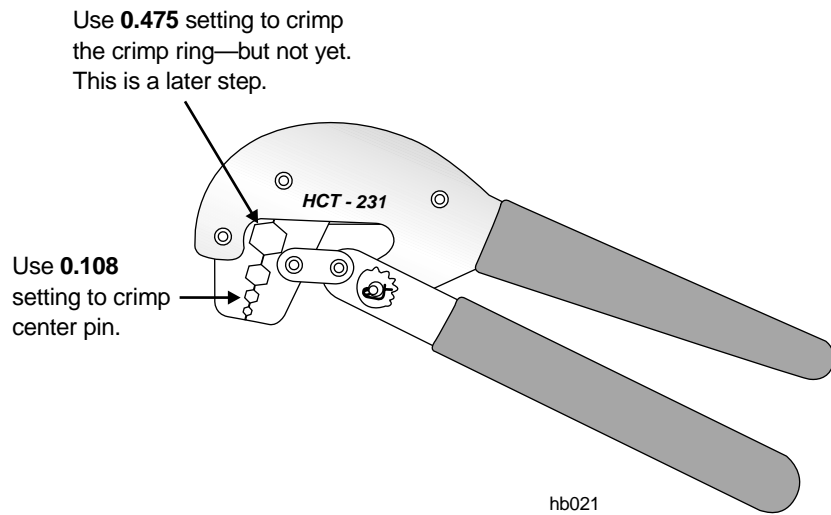
To install the cable connector, follow these steps.

1. Place the insulating washer against the dielectric.
2. Push the center pin (with guide pin attached) over the cable center conductor, as shown in figure C-7.



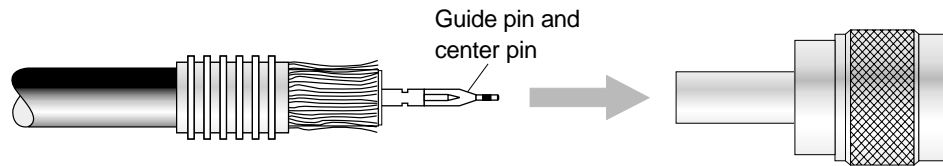
**Figure C-7 Installing the insulator and center pin**

3. Use the HCT-231 crimp tool (figure C-8) to crimp the center pin flush with the washer, as shown in figure C-7. If the center pin is bent after crimping, cut the cable, re-strip it, and attach a new center pin.

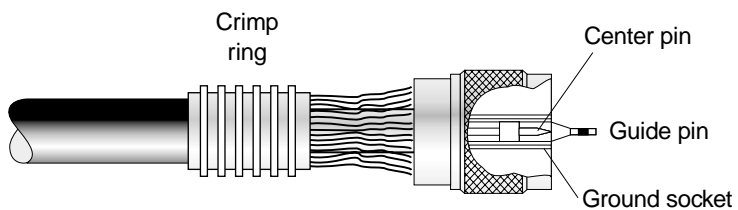


**Figure C-8 Crimping tool**

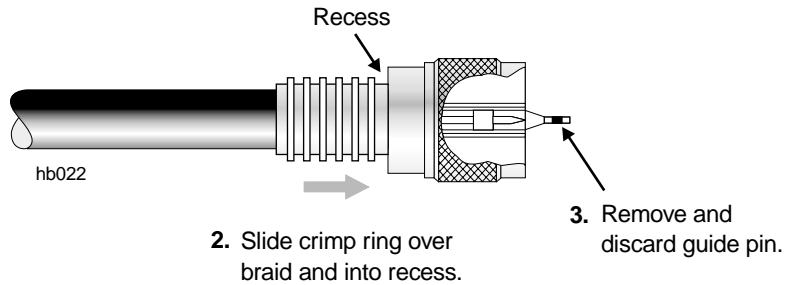
4. Follow the instructions in figure C-9 to install the connector body and crimp ring, and remove the guide pin.



1. Insert guide pin through back of connector body until the cable stops.



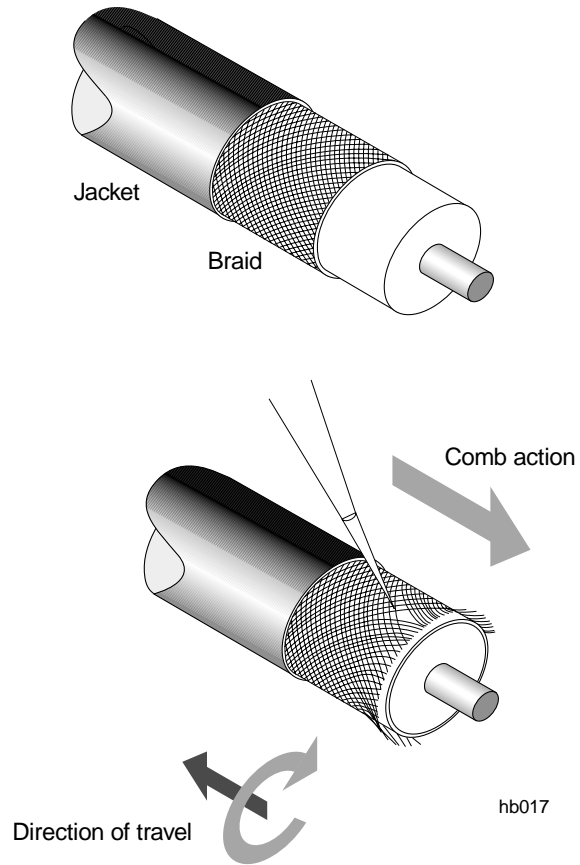
Center pin inside connector body



**Figure C-9 Installing the connector body and crimp ring**

5. **Important: Verify that the center pin aligns flush or within 1/64-inch from the ground socket edge.**  
If the pin is not flush or within this range, the connection will probably be faulty.

6. *Comb the braid only if the crimp ring will not fit over the shoulder and braid. If the crimp ring fits over the shoulder and braid, skip to step 7).*
  - a. Insert a pick or scribe into the braid and carefully comb the strands as shown in figure C-10. Start combing at the cut end. Comb the strands around the entire perimeter. Work backward, from the cut end toward the jacket—but always combing away from the jacket, as shown in figure C-10.



**Figure C-10 Combing the braid**

**Note:** Comb the braid all the way back to the jacket. If part of the braid is uncombed at the jacket end, stretching will cause the jacket and center pin to become loose, resulting in poor conductivity.

- b. Re-trim the braid to 7/16 inches (6 millimeters), as shown in figure C-5.

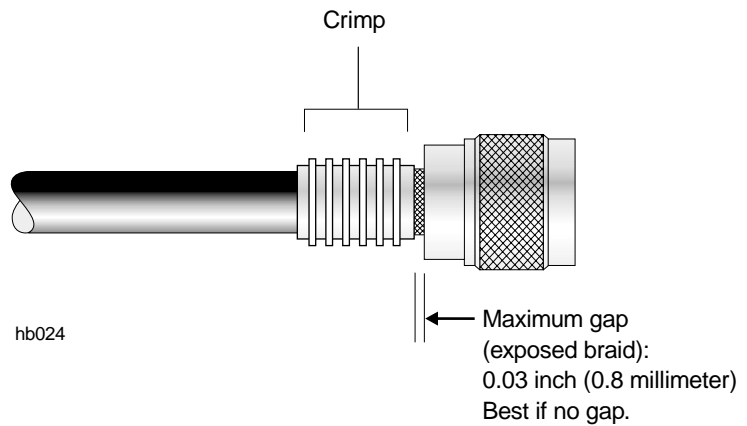
7. While holding the connector assembly together snugly, position the HCT-231 crimping tool, at setting 0.475, onto the area shown in figure C-11 and securely crimp the crimp ring into place.



### CAUTION

To avoid damaging the connector body, make sure the crimping tool does not touch the connector jam nut.

---



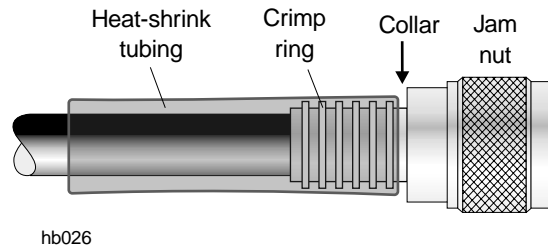
**Figure C-11 Crimp location**

**Note:** If the crimp ring slips and results in a gap greater than 0.03 inch (0.8 millimeter) between the crimp ring and the connector collar, reject the connection. Cut off the connector and start over.

## Applying heat-shrink tubing

Apply the heat-shrink tubing as follows:

1. Position the heat-shrink tubing near (but not touching) the jam nut, so it covers the crimp ring and a portion of the connector collar, as shown in figure C-12.



**Figure C-12 Heat-shrink tubing, properly placed for shrinking**

2. Using a heat gun, heat-shrink the tubing until it snugly fits around the cable, crimp ring, and part of the connector collar.

Point the connector upward. Begin heating at the connector end, and work toward the cable. The adhesive should flow away from the jam nut.



### CAUTION

Do not allow the cable jacket and dielectric to overheat. This can damage the cable and cause cable failure.

During heating, the tubing may shift and the adhesive lining may bleed. Make sure the adhesive does not bleed onto the jam nut and damage the connector.

*To install an additional N connector, repeat all steps above, beginning with the section Preparing the cable ends (page C-3).*

## A

- Abbreviations (identified), A- 1
- Access, buildings and equipment locations, 2–2
- Acronyms (identified), A- 1
- Adding SSIs, 10–2
- Adjusters for antenna azimuth and elevation, 4–11, 4–22
- Aligning the HT antenna, 4–6
- Antenna
  - adjusting azimuth, 4–18
    - fine adjustment, 4–22
  - adjusting elevation, 4–20
    - fine adjustment, 4–22
  - attaching to the antenna mount, 4–15
  - replacing, 10–6
- Antenna bracket, changing left–right orientation, 4–15
- Antenna mount
  - installing, 4–10, 4–13
  - parts (illustrated), 4–10
  - torque, 4–19, 4–21
  - torque wrench, 4–5
- ATM. *See* OC3c–ATM SSI
- Azimuth
  - adjusting, 4–18
    - fine adjustment, 4–22
  - explained and illustrated, 4–18
- Azimuth/elevation adjusters. *See* Adjusters (to adjust azimuth or elevation)

## B

- Ballast. *See* Concrete blocks
- Bend radius (IFL cable), 5–7, 5–13
- Blocks. *See* Concrete blocks (ballast)
- Boot message, 7–5
- Boot up sequence, 7–5
- Buttons on CCM, 6–35
  - functions, 6–36

## C

- Cable length
  - DS3–TDM SSI, 6–28
  - DS3–transparent SSI, 6–29
  - IFL, 5–4
  - OC3c–ATM SSI, 6–29
- Canadian Interference–Causing Equipment Regulations, B–2, B–3
- Canadian Standards Association, B–2, B–3
- CCM
  - See also* LCD
  - Boot message, 7–5
  - boot up sequence, 7–5
  - button functions, 6–36
  - buttons on front panel, 6–35
  - configuration downloading, 7–6
  - devices, 7–5
  - functions, 6–26
  - illustrated (front panel), 6–26
  - installing, 6–26
  - interfaces (clock and LAN), 6–28
  - LEDs, 6–37
    - indications, explained, 6–28
  - operational state, 7–6
  - power–on test, 6–37
  - replacing, 10–10
  - software downloading, 7–6
  - status, 7–7
  - SUDS, 6–38
  - troubleshooting, 9–2
- CCM redundancy bus cable, 6–34, 7–2
- Channel and control module. *See* CCM
- Chassis. *See* IDU chassis
- Checklist
  - installation tasks, 1–3
  - materials, 2–6
  - tools, 2–3
- Commissioning
  - prerequisites, 2–7, 7–2
  - procedure, 7–3
- Compass, 4–6
- Components to be installed, 1–3
- Concrete blocks (ballast), 3–10
  - arrangement on mount, 3–11

Configuration downloading (CCM), 7–6

#### Connections

- checking, 6–37, 8–3
- weatherproofing, 8–2

Corrugated metal roof, 3–11

Crimp tool, C–7

Customer equipment, connecting, 8–3

Customer sign-off, 8–3

## D

Devices, CCM, 7–5

Diagnostic mode, 6–35

Diameter of ODU mast, 4–5

Dismantling an HT, 10–14

Documents, related, vii

#### Drawings

- hub network schematic, 2–1
- hub reference drawing, 1–2
- hub rooftop drawing, 2–1

DS1 test, 7–11

DS1 test (fractional DS1), 7–15

DS3 test, 7–13

DS3 test (fractional DS3), 7–17

DS3–TDM SSI, 6–28

DS3–transparent SSI, 6–29

## E

Element Management System. *See* EMS

#### Elevation

- adjusting, 4–20
- fine adjustment, 4–22
- explained and illustrated, 4–20

Emissions, B–2, B–3

EMS, 2–7, 7–2

- database, 7–2

Equipment from other vendors, vii

equipment to be installed, 2–1

Ethernet switch (for hub LAN), description, 6–39

Existing structures as ODU mounts, 3–13

Exit (LCD), 6–36

## F

FAILED message, 7–4

Failure indication on CCM LCD, 6–39

FCC, B–2, B–3

Fractional DS1 test, 7–15

Fractional DS3 test, 7–17

Front panel display. *See* LCD

## G

#### Grounding

- lightning arrestor, 5–12
- ODU, 4–25
- power supply
  - ac, 6–14
  - dc, 6–16, 6–17
  - dual ac or dc, 6–12
- rack, 6–6

## H

Handling materials, 3–4

Heat-shrink tubing (for IFL cable), C–3, C–11

#### HT

- defined, 1–2
- dismantling, 10–14

HT alignment direction, 4–6

HT Disabled message, 7–3, 7–6

HT Enabled message, 7–3, 7–6

HT to RT connections tests, 7–11

Hub LAN router, description, 6–39

Hub LAN switch, description, 6–39

Hub rack, 6–2

- grounding, 6–6
- installing, 6–2
  - concrete floor, 6–3
  - wood floor, 6–4
- lifting, 6–3
- location, 6–2

Hub terminal. *See* HT



## I

- IDU, 6–7
  - See also* IDU chassis
  - components, 6–7
  - illustrated, 6–7
  - standards compliance, B–3
- IDU chassis
  - See also* IDU
  - connecting the IFL, 6–33
  - dc
    - circuit breaker, 6–22
    - disconnect device, 6–22
    - power–off circuit, 6–22
    - powering off, 6–22
  - LCD. *See* LCD
  - power supply, 6–8, 6–11
    - ac, 6–13
      - connecting power, 6–15
      - grounding, 6–14
    - dc, 6–16
      - connecting power, 6–18
      - grounding, 6–17
    - dual ac or dc, 6–11
  - power–on test, 6–25
  - rack mounting, 6–8
    - options, 6–8
  - replacing, 10–8
  - slots, numbering of, 6–7
  - specifications. *See* Hub and Remote Terminal Site Preparation Guide
  - temperature, 6–8
  - types, 6–8
- IEC, B–3
- IFL, replacing, 10–12
- IFL cable
  - bend radius, 5–7, 5–13
  - connecting to CCM (IDU), 6–33
  - connecting to ODU, 5–15
  - connections, 5–3
  - finishing the installation, 5–16
  - installing inside the building, 5–7
  - installing on the roof, 5–13
  - length, 5–7, 5–13
    - maximum, 5–4
  - moisture contamination, 8–2
  - penetration sleeve, 5–6
  - plan, 5–3
  - plenum (in conduit with power cables), 5–4
  - routing guidelines, 5–4
  - specifications, 5–2
  - terminating, C–1
  - testing, 5–15

- UL requirements, 5–2
- weatherproofing connections, 8–2

- Immunity, B–3
- Inclinometer, using, 4–21
- Indoor unit. *See* IDU and IDU chassis
- Inspecting the installed equipment, 8–3
- Installation checklist, 1–3
- Installation summary, 1–3
- Installers
  - number needed, vii, 3–4, 6–3
  - qualifications, vii
- Intrafacility link. *See* IFL cable

## L

- LAN connection, troubleshooting, 9–4
- LCD, 6–35, 6–38
  - See also* CCM
  - Boot message, 7–5
  - boot up sequence, 7–5
  - button functions, 6–36
  - buttons (for scrolling, selecting), 6–35
  - configuration downloading (CCM), 7–6
  - diagnostic mode, 6–35
  - exit, 6–36
  - FAILED message, 7–4
  - HT Disabled message, 7–3, 7–6
  - HT Enabled message, 7–3, 7–6
  - menu map, 6–36
  - operational state, 7–6
  - software downloading (CCM), 7–6
  - status conditions (explained), 7–7
  - status of CCM, SSIs, or ODU, 7–7
  - SUDS (diagnostics) sequence, 6–35, 6–38, 7–4
  - SUDS Completed message, 7–4
- LEDs
  - CCM, 6–37
  - indications, explained, CCM, 6–28
  - SSIs, 6–31
- Lightning arrester (for IFL), 5–3, 5–8
  - grounding, 5–12
- Lightning protection, 4–26
- Liquid crystal display. *See* LCD
- Location
  - hub rack, 6–2
  - IDU, 6–8
  - ODU, 3–3

## M

- MAC address, 7–2
- Magnetic declination, 4–6
- Main Menu (CCM LCD), 6–35
- Maintenance, 10–1
- Maps
  - local, requirements, 2–4, 4–5
  - magnetic declination, 4–6
  - plotting HT alignment directions, 4–6
  - true north, 4–6
- Mast, diameter, 4–5
- Mast mount, 3–2
  - location, 3–3
  - standard type, 3–6
    - assembly instructions, 3–6
  - types, 3–5
  - using existing structures, 3–13
- Materials
  - handling, 3–4
  - required for installation, 2–6
- Menu map for CCM LCD, 6–36
- Moisture contamination, 8–2
- Mounts. *See* Mast mount and Antenna mount
- Moving SSIs, 10–2
- Multiple IFL cables, 5–10

## N

- N connectors
  - attaching to IFL cable, C–6
  - location (IFL cable), 5–3
- National Electric Code (NEC), B–2

## O

- OC3c–ATM SSI, 6–29
- ODU, 4–1
  - connecting the IFL cable, 5–15
  - grounding, 4–25
  - illustration, 4–3
  - location, 2–1
  - replacing, 10–3
  - standards compliance, B–2
  - status, 7–9
  - transporting to the roof, 4–5
- ODU location, 3–3

- Operational state, 7–6
  - possible states, 7–6
- Outdoor unit. *See* ODU

## P

- Penetrating the roof, 5–5
- Penetration sleeve, 5–6
- Personnel
  - number of installers, vii
  - qualifications, installers, vii
- Power input requirement
  - ac power supply, 6–13
  - dc power supply, 6–16
- Power supply (IDU), 6–8, 6–11
  - ac, 6–13
    - connecting power, 6–15
    - grounding, 6–14
    - power input requirement, 6–13
  - dc, 6–16
    - connecting power, 6–18
    - grounding, 6–16, 6–17
    - power input requirement, 6–16
    - powering off, 6–22
  - dual ac or dc, 6–11
    - See also* Power supply (IDU), dc
  - grounding, 6–12
- Power-on test
  - CCM, 6–37
  - IDU chassis, 6–25
- Prerequisites
  - commissioning, 2–7, 7–2
  - installation, 2–1
- Publications, related, vii

## Q

- Qualifications for installers, vii

## R

- Rack
  - See also* hub rack
  - mounting, 6–8
  - options, 6–8
  - safety guidelines, 6–8
- Redundancy bus cable, 6–34, 7–2
- Related publications, vii
- Remote terminal (RT) installation, vii
- Repairs, 9–6

Replacing  
  antenna, 10–6  
  CCM, 10–10  
  faulty components, 9–6  
  IDU chassis, 10–8  
  IFL, 10–12  
  ODU, 10–3  
  SSIs, 10–11  
  transceiver, 10–4

RF arrester, 5–9, 5–14

Roof types, 3–5  
  corrugated metal, 3–11

Router (for hub LAN), 1–2, 6–2, 6–6  
  configuration, 7–2  
  description, 6–39

## S

Safety information, ix  
  rack mounting, 6–8

Sectors, definition and terminology, 4–9

Service loops, 5–7

Service-specific interface. *See* SSI

Site Data Record, 2–1

Site preparation, vii

Slots, IDU chassis  
  numbering of, 6–7  
  where CCM and SSIs are installed, 6–26,  
  6–28, 6–29, 7–8

Software downloading (CCM), 7–6

Spin-stripping tool (for IFL cable), C–3

SSIs, 7–2  
  adding, 10–2  
  DS3–TDM, 6–28  
  DS3–transparent, 6–29  
  function, 6–28  
  hot swapping, 10–2  
  installing, 6–30  
    chassis slots, 6–29, 10–2  
  LEDs, 6–31  
  moving, 10–2  
  numbering, 7–8  
  OC3c–ATM, 6–29  
  replacing, 10–11  
  status, 7–8  
  types, 6–28

Standards compliance, B–1

Startup diagnostics. *See* SUDS

State, 7–6

Status of CCM, SSIs, or ODU, 7–7

SUDS, 6–35, 6–38, 7–4  
  failure indication, 6–39  
  test and display sequence, 6–35, 6–38

SUDS Completed message, 7–4

Summary of installation, 1–3

Switch (for hub LAN), description, 6–39

## T

Task checklist, 1–3

Temperature, IDU chassis, 6–8

Terminating the IFL cable, C–1

Test set, 2–5

Testing

  DS1 test, 7–11

  DS3 test, 7–13

  fractional DS1 test, 7–15

  fractional DS3 test, 7–17

  HT to RT connections, 7–11

  IFL cable and connectors, 5–15

Tools required for installation, 2–3

Torque

  antenna mount, 4–19, 4–21

  rack safety bolts, 6–4

Torque wrench for antenna mount, 4–5

Transceiver

  attaching to the antenna, 4–23

  replacing, 10–4

Transmission equipment, 1–3

Troubleshooting, 9–1

  CCM, 9–2

  HT Disabled message, 9–6

  LAN connection, 9–4

True north, 4–6

## U

Underwriters Laboratories (UL), B–2, B–3

## W

Warnings (safety), explained, ix

Weatherproofing, 5–14, 8–2

Wrist strap (ESD), 6–26, 6–30