

HunterDouglas

Installation • Operation • Care

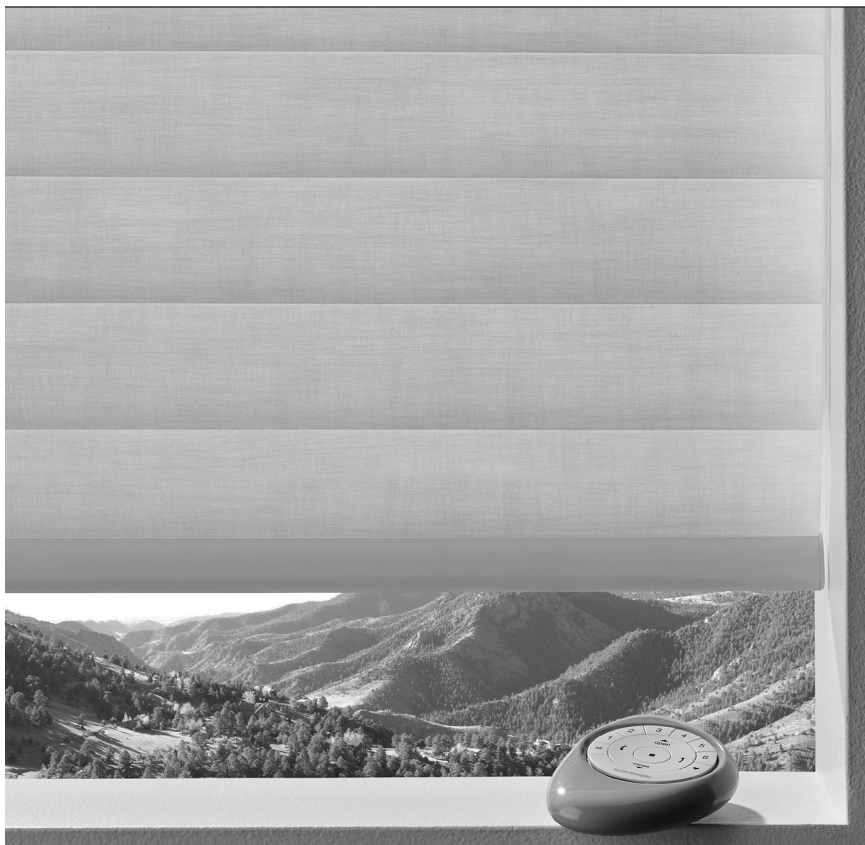

Sonnette™
Cellular Roller Shades
PowerView™ Motorization

CONTENTS

Getting Started:

Product View	1
Tools and Fasteners Needed	2

Installation:

Installation Overview	3
STEP 1 — Mount the Installation Brackets	3
Inside Mount	4
Outside Mount	6
STEP 2 — Install the Shade	8
STEP 3 — Connect the Power Source.....	9
Attach the Magnetic Hold-Down Brackets (Optional)	14

Operation:

Testing the Shade	15
Using the PowerView™ Remote	15
Resetting the Shade (If Necessary)	17
Troubleshooting	18

Care:

Removing the Shade	26
Cleaning Procedures	26

Declarations	27
---------------------------	----

Warranty	Back Cover
-----------------------	------------

Questions?

Call Hunter Douglas Consumer Support at **1-888-501-8364**.

Product View

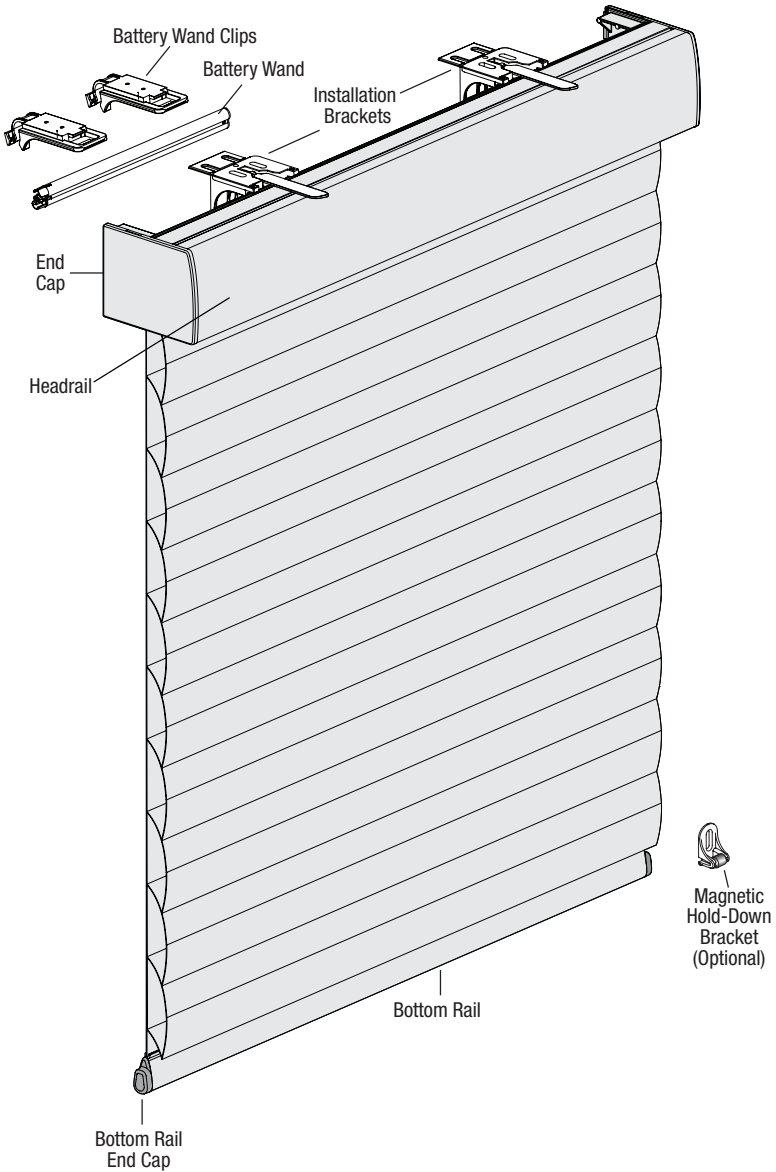

GETTING STARTED

Thank you for purchasing Hunter Douglas Sonnette™ Cellular Roller Shades. With proper installation, operation, and care, your new shades will provide years of beauty and performance. Please thoroughly review this instruction booklet and packing list before beginning the installation.

Tools and Fasteners Needed

- Flat blade and Phillips screwdrivers
- Level (laser level is recommended)
- Measuring tape and pencil
- Pliers
- Power drill, $\frac{3}{32}$ " drill bit, and $\frac{1}{4}$ " hex driver
- Scissors (heavy-duty)

In addition, you will need fasteners designed to work with your specific mounting surface(s).

- **#6 Hex Head Screws (Provided).** Two $1\frac{1}{2}$ " screws are provided per installation bracket.
- **Longer #6 Hex Head Screws (Not Provided).** If using spacer blocks, use #6 screws long enough for a secure attachment.
- **Speed Nuts and Screws (Provided).** Extension brackets come with screws and speed nuts.
- **Drywall Anchors (Not Provided).** Use drywall anchors when mounting into drywall.



**#6 x $1\frac{1}{2}$ "
Hex Head Screw**
(Provided)



**Longer #6 Hex Head Screw
for Use with Spacer Blocks**
(Not Provided)



**Speed Nut
and Screw**
(Provided with Each
Extension Bracket)

Installation Overview

To install your shade, you will need to perform the following three steps:

STEP 1: Mount the Installation Brackets

STEP 2: Install the Shade

STEP 3: Connect the Power Source

STEP 1 — Mount the Installation Brackets

- Your order will include the correct number of installation brackets for your shade width, as shown in the table below.
- Shade orders may also include spacer blocks or extension brackets, if they were specified for added clearance.

Installation Bracket

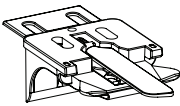

Shading Width	Brackets
14" – 36"	2
36 ¹ / ₈ " – 79"	3
79 ¹ / ₈ " – 96"	4
96 ¹ / ₈ " – 120"	5

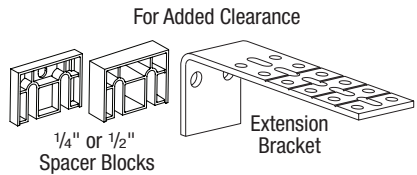

Mounting Types and Window Terminology

If the installation brackets are mounted correctly, the rest of the installation process follows easily. To prepare for this important first step, review the mounting types and basic window terminology illustrated below.

Molding

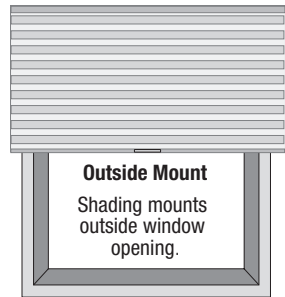
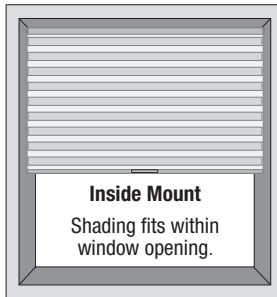
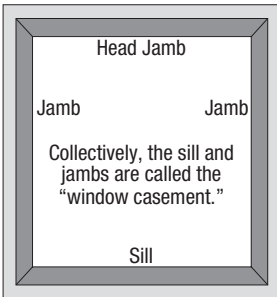

- Refer to the appropriate page below based on your order:
 - **Inside Mount — Page 4**
 - **Outside Mount — Page 6**

INSTALLATION

Mount the Installation Brackets — Inside Mount

Prepare the Installation Brackets

- **If using the optional back cover:** Use pliers or heavy duty scissors to remove the top tabs on the installation brackets.
 - Then remove the top tab on the back cover brackets.
 - Snap the prongs on the back cover brackets into the holes on the back of the installation brackets.
- **If not using the optional back cover:** Remove the top tab only on the installation brackets.

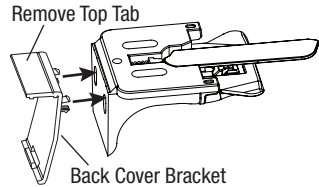
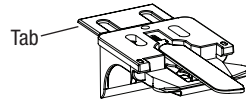

NOTE: Save these tabs once removed. They may be used as shims, if necessary.

Mount the Installation Brackets

- Mark 2" to 3" from each jamb for bracket location.
 - If more than two installation brackets came with your order, space additional bracket(s) evenly between the two end brackets and mark their location. Mount into wood whenever possible.

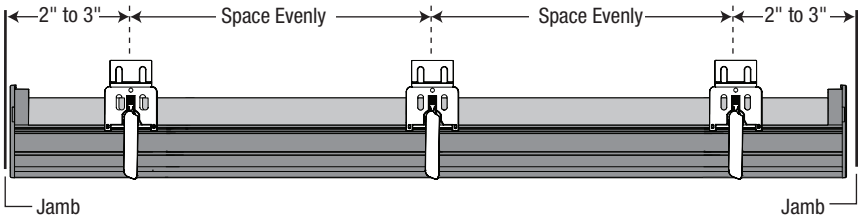

- Center the brackets on your marks and mark the location of the screw holes.

- The minimum casement depth required for installation brackets is 1".
- The minimum casement depth required for a fully recessed mount is $3\frac{3}{16}$ ".

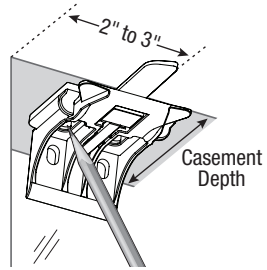

- Use a level to check that the mounting surface is level. Shim the brackets, if necessary (use the top tab that was removed from the brackets).
- Drill the screw holes using a $\frac{3}{32}$ " drill bit.

CAUTION: Use drywall anchors when mounting into drywall.

- Attach the installation brackets using the screws provided.

IMPORTANT: Do not overtighten the screws. Check to ensure the lever can be moved easily side to side. If not, loosen the screws in one-eighth turn increments until the lever can be moved easily.

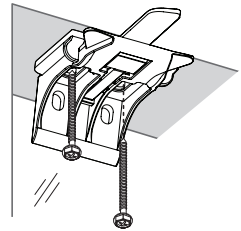

IMPORTANT: The front edges of the installation brackets must be level and aligned to each other.

- **If using the optional back cover:** Install the cover into the back cover brackets. If necessary, trim the back cover to the desired width.

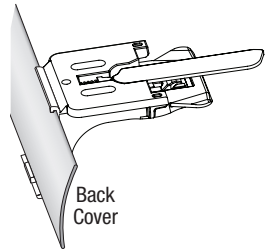

Proceed to "Install the Shade" on page 8.

INSTALLATION

Mount the Installation Brackets — Outside Mount

Prepare the Installation Brackets

- Use pliers or heavy duty scissors to remove the top tabs on the installation brackets.

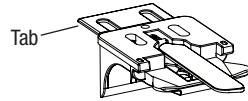

NOTE: Save these tabs once removed. They may be used as shims, if necessary.

Mount the Installation Brackets

- Center the headrail over the window opening at the desired height. Use a pencil to lightly mark each end of the headrail.
 - Alternatively, measure the width of the headrail and use that width to mark the headrail end points over the window opening.
- Mark 2" to 3" from each end of the headrail.
 - If more than two installation brackets came with your order, space additional bracket(s) evenly between the two end brackets and mark their location. Mount into wood whenever possible.

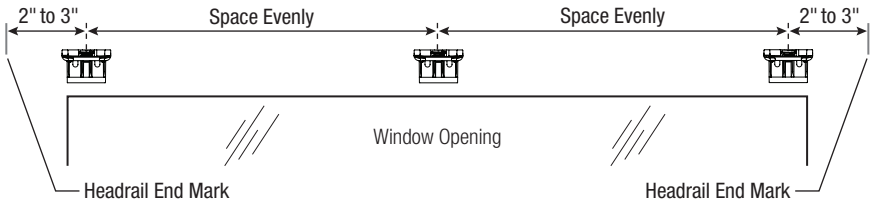

- Center the installation brackets or extension brackets on your marks and mark where to drill the screw holes.
 - A minimum 1 1/8" flat vertical surface is required for the installation brackets. Extension brackets require 1 1/4".
 - The tops of the installation brackets or extension brackets should be at the desired height. The brackets should be level and aligned.

CAUTION: The rear of the brackets must be flush against a flat mounting surface. Do not mount brackets on curved molding.

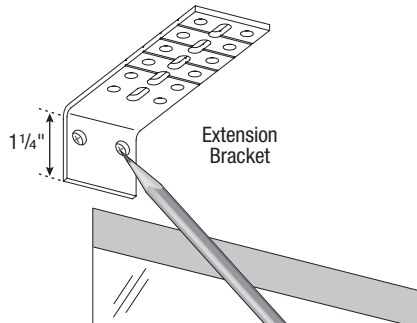
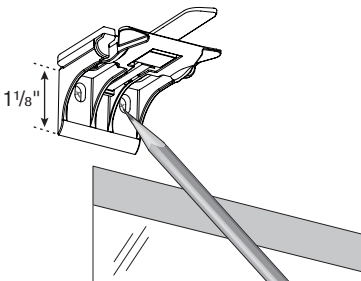

- Drill the screw holes using a $\frac{3}{32}$ " drill bit.

CAUTION: Use drywall anchors when mounting into drywall.

- Attach the installation or extension brackets using the screws provided.

IMPORTANT: The tops of the installation brackets or extension brackets must be level with their front edges aligned.

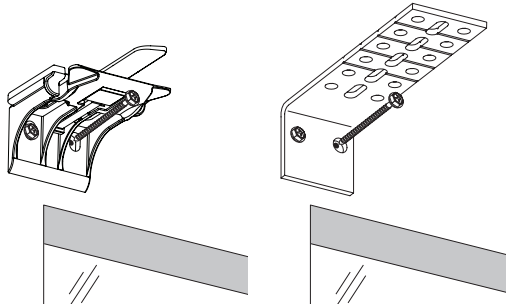

- If using spacer blocks, attach the spacer block(s) and installation bracket to a flat vertical mounting surface with #6 screws long enough for a secure installation.

IMPORTANT: Do not add more than $1\frac{1}{2}$ " of clearance using spacer blocks.

IMPORTANT: The tops of the installation brackets must be level with the front edges aligned.

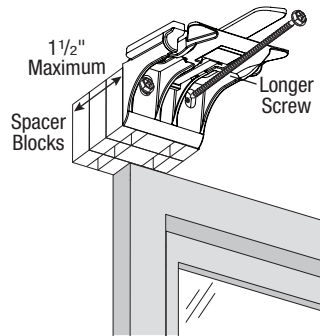

- If using extension brackets, attach an installation bracket to the underside of each extension bracket using the speed nuts and screws provided.

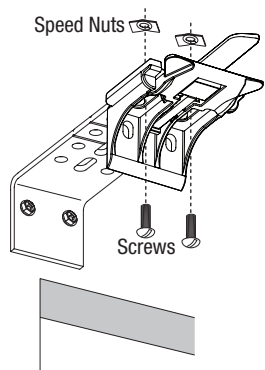

Proceed to "Install the Shade" on page 8.

INSTALLATION

STEP 2 — Install the Shade

- Peel back the protective covering from the top of the headrail. Leave the rest of the protective covering on the front of the headrail.

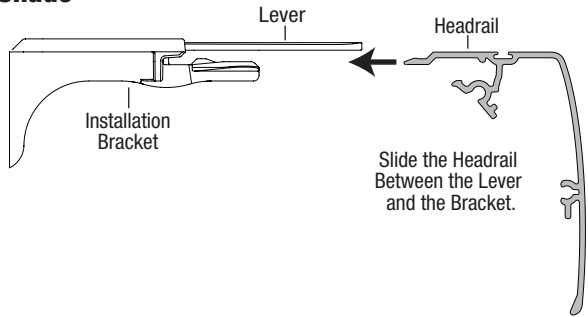

- Position the shade so that the front faces you.
- Slide the headrail into the installation brackets so the edge of the headrail is between the lever and the bracket, as shown.
- Firmly push the headrail into each bracket until it clicks and the lever snaps to the right side of the bracket.

IMPORTANT: Carefully pull on the headrail at each bracket to ensure it is installed securely.

- Completely remove the protective covering from the headrail.

Attach the Dust Cover (Optional for Outside Mounts)

The dust cover is used to protect the top of the headrail from exposure on outside mounted shades.

- Cut the dust cover to desired width.
- Remove the paper backing on one side of the hook and loop fastener dots.
- Apply the dots to the installation brackets on each end of the shades.

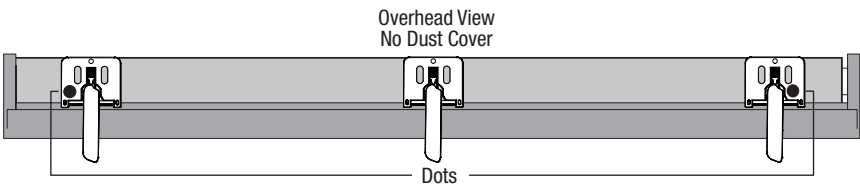
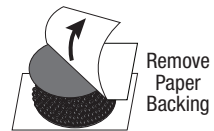

- Remove the remaining paper backing from the dots.
- Center the dust cover over the top of the shade, above the dots.
- Press the dust cover down onto the dots.

Dust Cover Installed

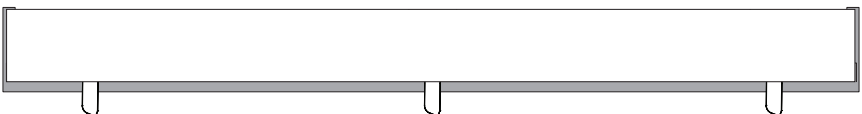

STEP 3 — Connect the Power Source

NOTE: When power is connected to the motor, a green LED inside the manual control button housing will flash to indicate the shade is ready for operation.

- Refer to the appropriate page based on your order.
 - For a battery wand, see below.
 - For a satellite battery pack, see page 10.
 - For an 18V DC power supply, see page 12.
 - For an 18V DC power supply with daisy-chain connections, see page 13.
 - For a C-size satellite battery wand or large DC power supply, see the instructions that came with the unit.

If You Have a Battery Wand...

Install the Batteries into the Battery Wand

- Squeeze the cap latch to release the cap.
- Remove the cap from the battery wand.
- Install the batteries according to the instructions on the battery wand label.
 - Hunter Douglas recommends AA alkaline batteries for use with our battery-powered shades. These will provide more than one year of operation, depending on usage. Lithium and rechargeable batteries are not recommended.
- Replace the cap.
 - Align the tab with the end of the wand.
 - Press the cap on until it latches.

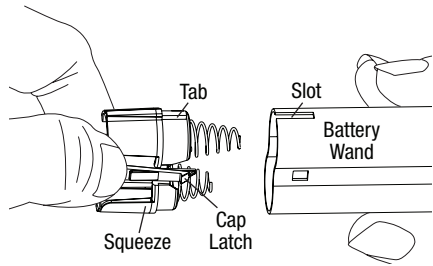

Mount the Battery Wand into the Battery Wand Clips

- Place the battery wand with its socket toward the motor end of the shade.
- Push the battery wand straight up into the battery wand clips until it snaps into place. Check to make sure the battery wand is secure.

CAUTION: Be sure the cables do not become pinched by the battery wand clips during installation. Damage or overheating of components could result.

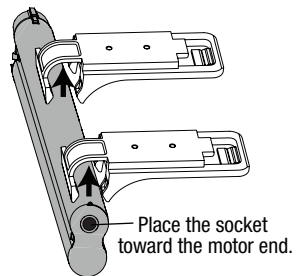

INSTALLATION

Plug the Power Cable into the Battery Wand

- From the back of the shade headrail, connect the power cable (from the motor side) into the socket on the battery wand.
- **Two-On-One Headrail Shades.** Plug in both cables to the battery wands.

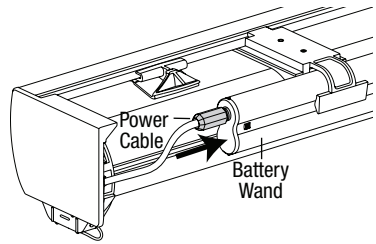

Install the Back Cover

- If using a back cover, install it into the back cover brackets, as shown.

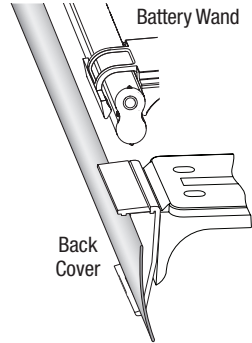

Proceed to “Attach Magnetic Hold-Down Brackets (Optional)” on page 14
or “Testing the Shade” on page 15.

If You Have a Satellite Battery Pack...

Install the Batteries into the Battery Wand

- See the instructions on the previous page.

Mount the Satellite Battery Pack

- Decide where you want to mount the satellite battery pack. A satellite battery pack may be mounted in any orientation.
- Mark the screw holes for the wall mount bracket.
- Drill the screw holes using a $\frac{3}{32}$ " drill bit.
- Remove the backing from the double-sided tape. Press the bracket into place.
- Attach the bracket using the screws provided.

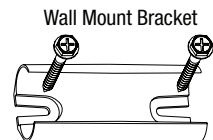

- Position the battery wand so the power cable is easily connected to the socket.
- Snap the battery wand into the wall mount bracket.

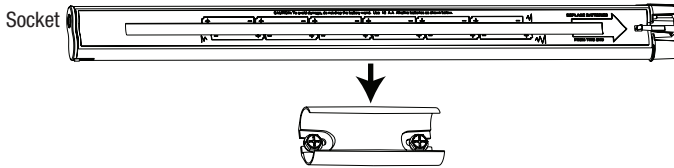

- Replace the cover with the slot aligned to the socket in the battery wand.

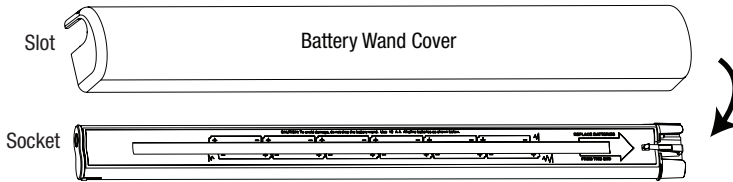

- Plug the power cable from the shade into the extension cable.
- Plug the other end of the extension cable into the socket in the battery wand.
- **Two-On-One Headrail Shades.** Plug in both power cables into the extension cables and then plug both extension cables into the sockets in the battery wands.

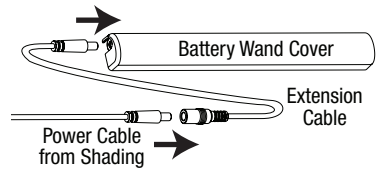

Proceed to “Attach Magnetic Hold-Down Brackets (Optional)” on page 14
or “Testing the Shade” on page 15.

INSTALLATION

If You Have a DC Power Supply...

Connect the Power Supply

- Plug the power cable from the shade into the extension cable.
- Plug the other end of the extension cable into the DC power supply.
- Plug the DC power supply into a standard outlet.
- Secure the extension cable using wire retainers (not supplied). If hiding the cable behind the shade, make sure it does not impede the operation of the shade.
- Space the wire retainers approximately 15" apart along the power supply cable, as shown.



WARNING: Keep cords and small parts out of the reach of children. They can wrap cords around their necks and **STRANGLE**. They can also put small parts in their mouths and **CHOK**.



WARNING: Electric shock and/or a fire hazard may occur, if not properly installed.

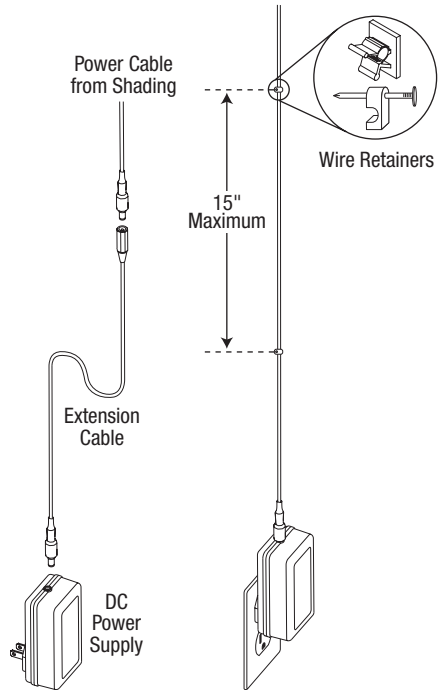

Proceed to “Attach Magnetic Hold-Down Brackets (Optional)” on page 14
or “Testing the Shade” on page 15.

If You Have a DC Power Supply with Daisy-Chain Connections...

The daisy-chain feature allows up to three PowerView™ shades to be powered by a single DC power supply. However, each shade can operate independently. The daisy-chain feature is only available with the DC power supply option.

- Route the power cables from each shade to the connector, using an extension cable, if necessary.
- Plug an extension cable into the connector and plug the cable into the DC power supply. Two extension cables and two connectors are used for three shades.

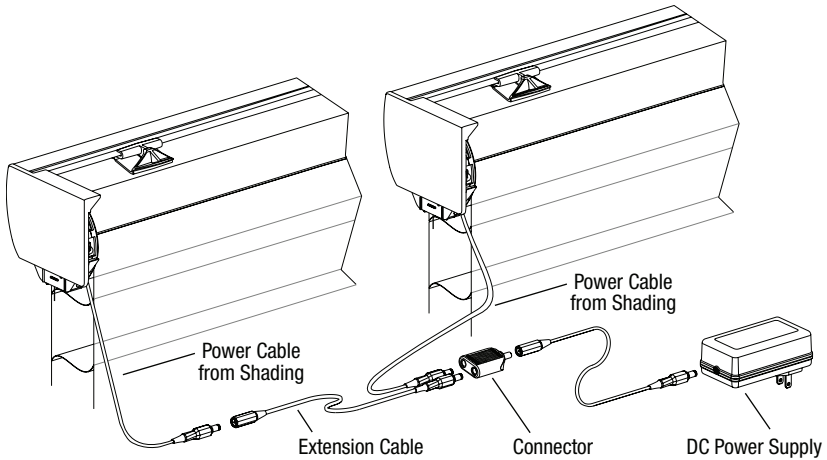

- Plug the DC power supply into a standard outlet.

Two-On-One Headrail Shades

- Route the power cables from each side of the shade to the connector. Use extension cables, if necessary.
- Plug the extension cables or power cables into the connector and plug the cable into the DC power supply.

Proceed to “Attach Magnetic Hold-Down Brackets (Optional)” on page 14
or “Testing the Shade” on page 15.

INSTALLATION

Attach the Magnetic Hold-Down Brackets (Optional)

- Lower the shade.
- Place the magnetic hold-down bracket onto the bottom rail just inside the end cap, oriented as shown.
- Mark the screw location using the mounting options shown below.
 - The screw should be placed in the middle of the channel. This will allow for adjustment.

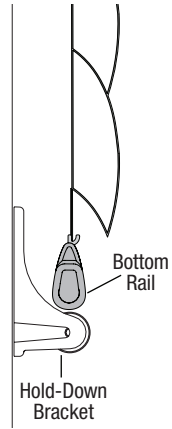

Outside Mount

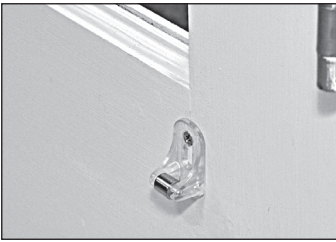

Preferred



Alternate

Inside Mount



Preferred



Alternate

- Drill the screw holes using a $\frac{3}{32}$ " drill bit.
- Attach the hold-down brackets to the mounting surface using the screws provided.

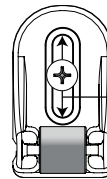

Adjust bracket height by loosening the screw and sliding the bracket up or down.

Testing the Shade

Use the manual control button to test the shade and ensure that the motor and power source are working correctly.

- Press the manual control button to lower the shade. If the shade does not operate, see “Troubleshooting” on page 20.
- Test vane operation by pressing the manual control button to open the vanes and then pressing it again to close the vanes.
- After the vanes are fully closed, press the manual control button to raise the shade.

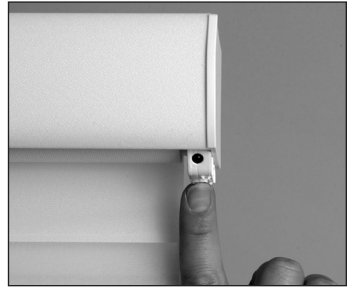

CAUTION: When raising the shade for the first time, observe how the fabric rolls up into the headrail. It should roll up evenly. If the bottom rail is not level or the shade starts to rub against either window jamb, immediately press the manual control button to stop the shade. See “Adjust the Bottom Rail Weight” on page 23.

- **Two-On-One Headrail Shades** have two motors and two battery packs. The right motor operates the right shade and the left motor operates the left shade. Use the manual control buttons on each side to test the two shades individually.

Using the PowerView™ Remote

First, activate the remote by pulling both plastic tabs from the back battery compartment.

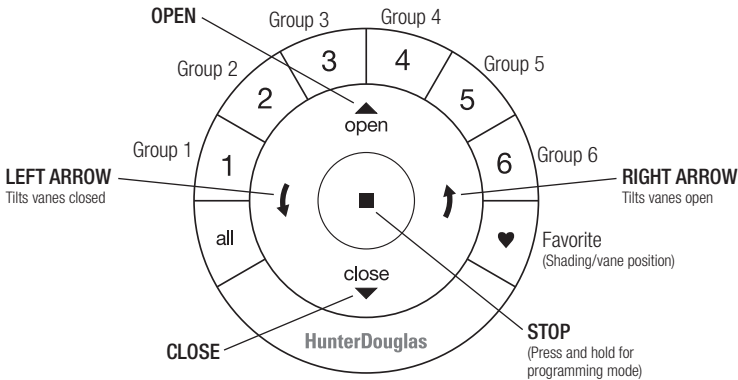

IMPORTANT: If you have more than one remote, see “Adding Additional Remote(s) to the PowerView™ Shade Network” in the *PowerView Motorization Remote Control Guide*.

OPERATION

Joining a Shade to a Group

IMPORTANT: The shade will not operate using the remote until it has been joined to a group.

1. Press and hold ■ STOP for 4 seconds to put the remote in program mode. The lights on the remote will flash to indicate it is in program mode.
2. Press the desired group number (1 – 6) on the remote. The backlight for the group number will flash to show it is selected.
3. Press and hold the manual control button on the shade.
4. While continuing to press the manual button, press ▲ OPEN on the remote. The shade will move slightly to indicate it has joined the group. Release the manual control button.
5. Press and hold ■ STOP for 4 seconds to exit program mode. The lights will stop flashing.

Basic Operation

1. To wake up the remote, simply pick it up or press ■ STOP. The last group(s) selected will be highlighted and active.
2. Press “all” or groups 1 – 6 to select specific shade(s) to move. Selected group button(s) will light to show they are selected.
 - a. Multiple group buttons may be selected at a time.
 - b. To deselect a group, press the group button again. The backlight for that group button will go out.
3. Press ▼ CLOSE to lower the selected shade(s).
4. Press the right arrow to open the vanes.
5. Press the left arrow to close the vanes.
6. Press ▲ OPEN to raise the selected shade(s).
7. Press ■ STOP to stop shade or vane movement anywhere along its travel.
8. While a shade is in motion, press the opposite of shade motion (▲ OPEN or ▼ CLOSE) to reverse direction.
9. Press ♥ FAVORITE to send selected shade(s) to your preset “favorite” position. Refer to the *PowerView™ Motorization Remote Control Guide* on how to set a favorite position.

Operating Tips

1. When the shade is raised, pressing the right arrow will first lower the shade and then open the vanes.
2. When the shade is lowered with the vanes open, pressing ▲ OPEN will first close the vanes and then raise the shade all the way.

Further Operation and Programming Information

PowerView™ Pebble™ Remote and/or PowerView Surface Remote Operation

For information regarding operation and programming of the PowerView remote, refer to your *PowerView Motorization Remote Control Guide*.

PowerView Scene Controller

For information regarding operation and programming of the PowerView Scene Controller, refer to your *PowerView Motorization Scene Controller Guide*.

PowerView App Operation

The PowerView Hub is required for PowerView App operation. For information regarding setup and operation using the PowerView App, refer to the online *PowerView App Software Guide* at hunterdouglas.com/powerview/support.

Resetting the Shade (If Necessary)

Basic Reset

The basic reset is used to reset the shade's travel limits.

1. Press and hold the manual control button for 6 seconds. The shade will move slightly.
2. Release the manual control button. The shade will raise to its fully open position to set the upper travel limit, then lower to the fully closed position with vanes open to set the lower travel limit. The shade will move slightly one more time to indicate that the travel limits have been reset.

Resetting Shade Programming

This reset erases all shade programming from memory, including group assignments, preventing any input device from operating the shade. Its primary use is during installation to correct group and network assignments. This reset does not affect travel limits.

1. Press and hold the manual control button for 12 seconds. The shade will move slightly after 6 seconds, then again after 12 seconds. Release the button.
2. Refer to "Joining a Shade to a Group" on page 18 to program the shade to a group.

Troubleshooting

If your shade is not operating correctly:

- First review the guide that came with your control device.
- Refer to the following troubleshooting procedures for specific solutions for your shade.

If questions remain, please contact the Hunter Douglas Customer Information Center at **1-888-501-8364**.

Problem	The shade will not snap into the installation brackets.
Solution	Check that the installation brackets are aligned and level. Check that the locking tab on the installation bracket slides over the headrail.
Problem	The shade will not raise.
Solution	If the hold-down brackets have been used, make sure they have been released.
Problem	The shade does not roll up, or it rolls up too slowly.
Solution	<p>If the hold down brackets have been used, make sure they have been released.</p> <p>Check that the shade is being raised straight up and is not skewing the fabric against the headrail. If this is not the case, you can adjust by:</p> <p><u>Adding Spring Tension</u></p> <ul style="list-style-type: none"> ■ Locate the adjustment behind the LEFT end cap cover. <ul style="list-style-type: none"> ➤ The cover is removed by placing your thumb in the center and releasing the snap on the top back corner. ■ Raise the shade completely and hold into place. ■ Push a 3/16" Allen wrench into the access hole in the end cap of the shade (about a 1/2"). <p>CAUTION: When pressing the Allen wrench into the end, you are compressing a spring and freeing the lock from engagement.</p> <p>To re-engage the lock, simply pull the Allen wrench straight out of the end cap access hole.</p> <ul style="list-style-type: none"> ➤ Using 1/2 turn increments, rotate Allen wrench counter-clockwise to add tension. Test and repeat, if necessary.

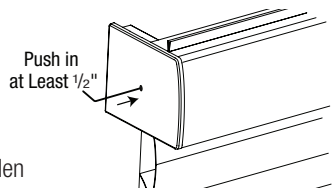

Problem	The shade will drift up once stopped.
Solution	<p>Removing Spring Tension</p> <ul style="list-style-type: none"> ■ Locate the adjustment behind the LEFT end cap cover. <ul style="list-style-type: none"> ➤ The cover is removed by placing your thumb in the center and releasing the snap on the top back corner. ■ Raise the shade completely and hold into place. ■ Push a $\frac{3}{16}$" Allen wrench into the access hole in the end cap of the shade (about a $\frac{1}{2}$"). <p>CAUTION: When pressing the Allen wrench into the end, you are compressing a spring and freeing the lock from engagement.</p> <p>To re-engage the lock, simply pull the Allen wrench straight out of the end cap access hole.</p> <ul style="list-style-type: none"> ➤ Using $\frac{1}{2}$ turn increments, rotate Allen wrench counter-clockwise to add tension. Test and repeat, if necessary.
Problem	The shade is hard to raise or lower, or will not raise or lower.
Solution	<p>Shades cannot be forced into tight inside mount window openings. If an inside mount, make sure there is clearance between the ends of the shade and the window casement.</p> <p>Check that the installation brackets are level. Shim to level, if necessary.</p>
Problem	Vanes do not align on side-by-side shades.
Solution	<p>Vane alignment is only guaranteed within $\frac{1}{4}$" when shades are ordered at the same time, at the same height, with the same color and fabric, and when specified on the order form.</p> <p>Check that the windows are square and the same height.</p>

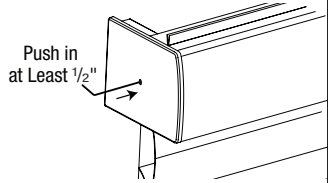

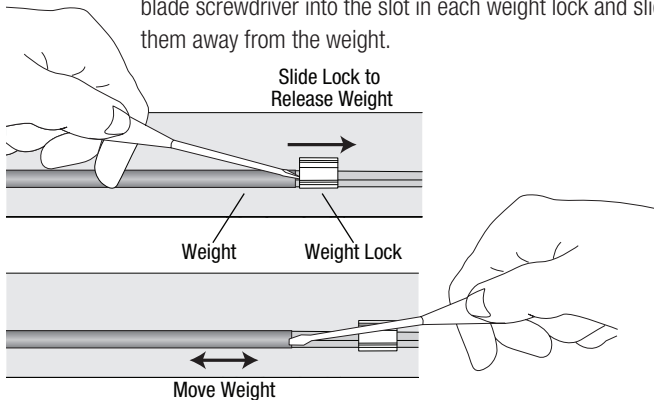
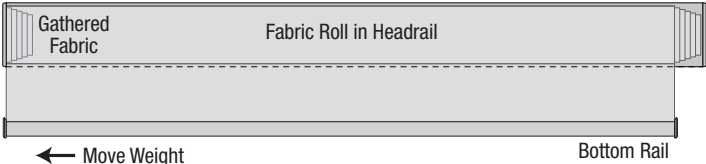
<p>Problem</p>	<p>The shade raises or lowers unevenly, the bottom rail is not level when fully raised, or the fabric winds unevenly or starts to rub against one end of the headrail.</p>
<p>Solution</p>	<p>Keep the bottom rail level while raising the shade. Side-to-side movement while raising the shade may cause fabric to skew.</p> <p>Check that the window is square by measuring the diagonals.</p> <p>Check that the installation brackets are level. Shim to level, if necessary.</p> <p>If the headrail is level and the window is square, adjust the bottom rail weight.</p> <p>Adjusting the Bottom Rail Weight</p> <p>IMPORTANT: Only adjust the bottom rail weight if the fabric does not roll up straight into the headrail.</p> <p>First, release both weight locks. On the back of the bottom rail, insert a flat-blade screwdriver into the slot in each weight lock and slide them away from the weight.</p>  <p>Slide the weight, in 1" increments, in the direction the fabric is gathering.</p>  <p>Secure the weight by sliding each lock back in position next to the weight.</p> <p>Test and, if necessary, adjust again.</p>

Problem	The shade will not fit into the installation brackets.
Solution	<p>If the shade has a battery wand, check that the wand is not interfering with the installation brackets.</p> <p>Check that the installation brackets are level and aligned. Adjust and/or shim to level, if necessary.</p> <p>Be sure the heads of the mounting screws are flush against the installation bracket.</p> <p>Check that the headrail is completely inserted into the installation brackets. See “STEP 2 — Install the Shade” on page 10.</p>
Problem	The shade does not operate using the manual control button.
Solution	<p>Unplug the power cable from the motor, then plug it back in. A green LED inside the manual control button housing should flash to indicate the motor has power.</p> <p>Check that the batteries in the battery wand, satellite battery pack, or C-size satellite battery wand are correctly inserted and fresh.</p> <p>Check that the battery wand, satellite battery pack, C-size satellite battery wand, or DC power supply is securely connected to the power cable and the cables are not pinched or caught in the headrail or installation brackets.</p>
Problem	The shade is not responding to the PowerView™ remote.
Solution	<p>IMPORTANT: A shade will not operate using the remote until it has been joined to a group</p> <p>Check that the correct group number is selected.</p> <p>Check that the batteries in the remote are correctly inserted and are fresh. The LEDs that backlight the remote should come on full bright when ■ STOP is pressed.</p>
Problem	The vanes do not open when the shade is first operated.
Solution	<p>Make sure the shade is completely lowered.</p> <p>Open and close the shade several times to help open the vanes. If necessary, gently pull down on the bottom rail.</p>

OPERATION

Problem	The shade is hard to raise or lower, or the bottom rail does not stop at the top limit.	
Solution	<p>Check the adjustment position of both limit stops. The top illustration shows the correct adjustment. The limit stop catches the bottom rail, and the bottom of the limit stop is slightly above or barely touching the fabric roll.</p> <p>In the second illustration, the limit stop adjustment is too tight. The fabric may not drop freely and could even be damaged when the shade is raised. To correct this, the limit stop should be adjusted one step up. Simply pull back on the rear of the limit stop to adjust its position.</p> <p>In the bottom illustration, the adjustment is too loose. The bottom rail can slip under the limit stop. If the bottom rail rotates through the headrail, it must be backed out before adjusting the limit stop.</p> <p>IMPORTANT: Both limit stops must be adjusted to the same position or else skewing may occur.</p>	<p>The diagrams illustrate three scenarios of limit stop adjustment on a shade headrail:</p> <ul style="list-style-type: none">Top Diagram: Shows the correct adjustment. The limit stop catches the bottom rail, and the bottom of the limit stop is slightly above or barely touching the fabric roll. Labels: Headrail, Limit Stop, Bottom Rail, Fabric Roll.Middle Diagram: Shows the limit stop adjustment is too tight. The fabric may not drop freely and could even be damaged when the shade is raised. To correct this, the limit stop should be adjusted one step up. Simply pull back on the rear of the limit stop to adjust its position. Label: Pull Back to Adjust.Bottom Diagram: Shows the adjustment is too loose. The bottom rail can slip under the limit stop. If the bottom rail rotates through the headrail, it must be backed out before adjusting the limit stop. Label: Pull Back to Adjust.

Problem	The bottom rail does not raise or lower completely, or its location when fully lowered has changed over time.
Solution	<p>The batteries may be low in the battery wand, satellite battery pack, or C-size satellite battery wand. Replace the batteries.</p> <p>Check that the battery wand, satellite battery pack, C-size satellite battery wand, or DC power supply is securely connected to the power cable and the cables are not pinched or caught in the headrail or installation brackets.</p> <p>Check that there is clearance between the ends of the shade and the window casement on inside mounts.</p> <p>Check if the fabric rolls up evenly into the headrail. If not, see “Adjust the Bottom Rail Weight” on page 23.</p> <p>Reset the travel limits. See “Resetting the Shade” on page 19.</p> <p>See the <i>PowerView™ Motorization Remote Control Guide</i> for operation or programming troubleshooting solutions.</p>
Problem	Adjacent shades do not roll up evenly.
Solution	<p>It is considered normal if the roll-up on both shades is within $\frac{5}{16}$" of each other. If one shade rolls up tighter than another, lower and raise both shades several times.</p> <p>Reset the shade. See “Resetting the Shade” on page 19.</p> <p>Check that the shade fabric is not catching on any brackets or components.</p> <p>Check that the fabric winds evenly and does not rub against the headrail. If uneven, see “Adjust the Bottom Rail Weight” on page 23.</p>
Problem	Two-On-One Headrail Shades Only: The center gap is not even from the top to the bottom of the shade, interfering with the function of the shade.
Solution	Ensure the entire length of the headrail is straight and level. If the center portion of the headrail is higher than the ends, the center gap will close together. If the center portion of the headrail is lower than the ends, the center gap increases. If necessary, adjust the height of each bracket by moving it within the screw slots or by using shims.

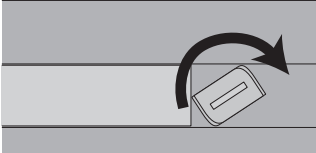
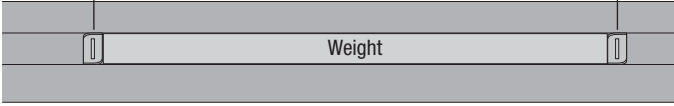
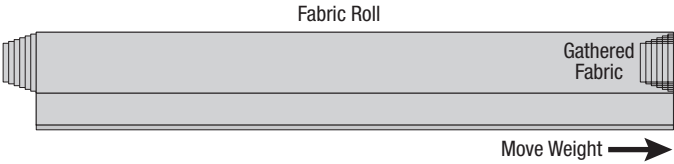
<p>Problem</p>	<p>The shade raises or lowers unevenly, the fabric rubs against one end of the headrail, or the bottom rail is uneven when fully raised.</p>
<p>Solution</p>	<p>Check that the window is square by measuring the diagonals. Check that the installation brackets are level. Shim to level, if necessary.</p> <p>Adjust the Bottom Rail Weight:</p> <ul style="list-style-type: none">■ Release the weight clips by inserting a flat blade screwdriver into the weight clip and turning clockwise.  <p>Weight Clip Bottom Rail Weight Clip</p>  <p>Weight</p> <ul style="list-style-type: none">■ Move the weight in 1" increments toward the side where the fabric is gathering.  <p>Fabric Roll Gathered Fabric</p> <p>Move Weight →</p> <ul style="list-style-type: none">■ Secure the weight clips in position by turning them counterclockwise after making the adjustment.■ Test and, if necessary, adjust again.

Problem	The vanes do not close fully when the shade stops in the lowest position.
Solution	<p>The shade should be programmed to stop in its lowest position with the vanes closed. A small distance between the front and back fabric facings in the fully closed position is normal.</p> <ul style="list-style-type: none"> ■ If this distance is excessive or moves over time, open the shade to its full “vane open” position and try again. If this does not correct the problem, reset the bottom limit. See “Resetting the Shade” on page 19. ■ See the <i>PowerView™ Motorization Remote Control Guide</i> for operation or programming troubleshooting solutions.
Problem	The shade raises from the sill when the vanes are closed.
Solution	<p>A small gap between the sill and the bottom of the shade is normal in the fully lowered “vane closed” position. The gap is necessary to allow for the unimpeded movement of the bottom rail.</p> <ul style="list-style-type: none"> ■ If this distance is excessive or moves over time, open the shade to its full “vane open” position and try again. If this does not correct the problem, reset the bottom limit. See “Resetting the Shade” on page 19. ■ See the <i>PowerView Motorization Remote Control Guide</i> for operation or programming troubleshooting solutions.
Problem	The front fabric appears to cling to the back fabric.
Solution	Lightly apply a static spray for home furnishings. Follow the manufacturer’s directions. Allow the shade to dry in the fully lowered position. If necessary, reapply the static spray each time the shade is professionally cleaned.

Removing the Shade

- Move each lever of the installation brackets to the left to release the shade.

- A flat blade screwdriver can be used to move the lever.

CAUTION: Be very careful not to tear or damage the fabric.

- If the lever is inaccessible or inoperable, lower the shade until you can see the underside of the bracket. Carefully reach a small flat blade screwdriver behind the shade to the tab on bottom of the bracket between the screw holes.
- Push the tab away from the shade and pull the headrail to release it from the bracket.

- Carefully pull the shade to remove it from the brackets.

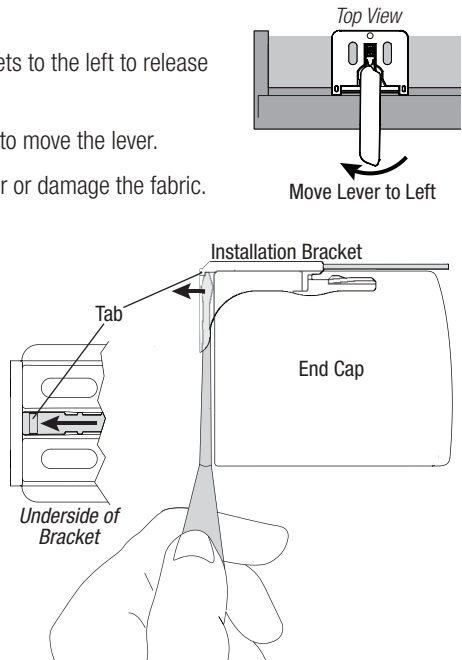

Cleaning Procedures

Sonnette™ Cellular Shades are made from anti-static, dust-resistant materials which repel dirt and dust. The following options are available if your shade needs cleaning.

CAUTION: Do not steam the shades.

Dusting

- Regular light dusting with a feather duster is all the cleaning that needed in most circumstances.

Vacuuming

- Use a hand-held vacuum with low suction for more thorough dust removal.

Spot-Cleaning

CAUTION: Do not use spot clean treatment on Highline™, Textura™ and Elan™ Metallic fabrics.

- Prepare a solution of warm water and a mild detergent.
- Dampen a clean cloth in the solution and wring it out.
- Dab the spot with the dampened cloth until it is gone. Do not rub the fabric.
- Allow the shade to dry in the completely lowered position.

U.S. Radio Frequency FCC Compliance

FCC ID information is located behind the motor-side end cap. The end cap may be removed to view this information.

This device complies with Part 15 of the FCC Rules. Operation is subject to the following two conditions:

- (1) This device may not cause harmful interference, and
- (2) This device must accept any interference received, including interference that may cause undesired operation.

This equipment has been tested and found to comply with the limits for a Class B digital device, pursuant to Part 15 of the FCC Rules. These limits are designed to provide reasonable protection against harmful interference in a residential installation. This equipment generates, uses and can radiate radio frequency energy and, if not installed and used in accordance with the instructions, may cause harmful interference to radio communications. However, there is no guarantee that interference will not occur in a particular installation. If this equipment does cause harmful interference to radio or television reception, which can be determined by turning the equipment off and on, the user is encouraged to try to correct the interference by one or more of the following measures:

- Reorient or relocate the receiving antenna.
- Increase the separation between the equipment and receiver.
- Connect the equipment into an outlet on a circuit different from that to which the receiver is connected.
- Consult the dealer or an experienced radio/TV technician for help.

Any changes or modifications not expressly approved by the party responsible for compliance could void the user's authority to operate the equipment.

Industry Canada

Under Industry Canada regulations, this radio transmitter may only operate using an antenna of a type and maximum (or lesser) gain approved for the transmitter by Industry Canada. To reduce potential radio interference to other users, the antenna type and its gain should be so chosen that the equivalent isotropically radiated power (e.i.r.p.) is not more than that necessary for successful communication.

This device complies with Industry Canada licence-exempt RSS standard(s). Operation is subject to the following two conditions: (1) this device may not cause interference, and (2) this device must accept any interference, including interference that may cause undesired operation of the device.

Class B Digital Device Notice

This Class B digital apparatus complies with Canadian ICES-003, RSS-Gen and RSS-210.
CAN ICES-3 (B)/NMB-3(B)

European Conformity

We, the undersigned,

Hunter Douglas Window Fashions
One Duette Way, Broomfield, CO 80020, USA

Hunter Douglas Europe B.V.
Piekstraat 2, 3071 EL Rotterdam, The Netherlands

certify and declare under our sole responsibility that assembly PV4 conforms with the essential requirements of the EMC directive 2004/108/EC and R&TTE directive 1999/5/EC.

A copy of the original declaration of conformity may be found at:

www.hunterdouglas.com/RFcertifications.



LIFETIME GUARANTEE

The Hunter Douglas® Lifetime Guarantee is an expression of our desire to provide a thoroughly satisfying experience when selecting, purchasing and living with your window fashion products. If you are not thoroughly satisfied, simply contact Hunter Douglas at (888) 501-8364 or visit hunterdouglas.com. In support of this policy of consumer satisfaction, we offer our Lifetime Limited Warranty as described below.

COVERED

BY A LIFETIME LIMITED WARRANTY

- Hunter Douglas window fashion products are covered for defects in materials, workmanship or failure to operate for as long as the original retail purchaser owns the product (unless shorter periods are provided below).
- All internal mechanisms.
- Components and brackets.
- Fabric delamination.
- Operational cords for a full 7 years from the date of purchase.
- Repairs and/or replacements will be made with like or similar parts or products.
- Hunter Douglas motorization components are covered for 5 years from the date of purchase.

NOT COVERED

BY A LIFETIME LIMITED WARRANTY

- Any conditions caused by normal wear and tear.
- Abuse, accidents, misuse or alterations to the product.
- Exposure to the elements (sun damage, wind, water/moisture) and discoloration or fading over time.
- Failure to follow our instructions with respect to measurement, proper installation, cleaning or maintenance.
- Shipping charges, cost of removal and reinstallation.

Hunter Douglas (or its licensed fabricator/distributor) will repair or replace the window fashion product or components found to be defective.

TO OBTAIN WARRANTY SERVICE

1. Contact your original dealer (place of purchase) for warranty assistance.
2. Visit hunterdouglas.com for additional warranty information, frequently asked questions and access to service locations.
3. Contact Hunter Douglas at (888) 501-8364 for technical support, certain parts free of charge, for assistance in obtaining warranty service or for further explanation of our warranty.

NOTE: In no event shall Hunter Douglas or its licensed fabricators/distributors be liable or responsible for incidental or consequential damages or for any other indirect damage, loss, cost or expense. Some states do not allow the exclusion or limitation of incidental or consequential damages, so the above exclusion or limitation may not apply to you. This warranty gives you specific legal rights, and you may also have other rights which vary from state to state.

Different warranty periods and terms apply for commercial products and applications.

HunterDouglas 
hunterdouglas.com

XXXXXXXXXX



9/16