

# HunterDouglas

Installation • Operation • Care

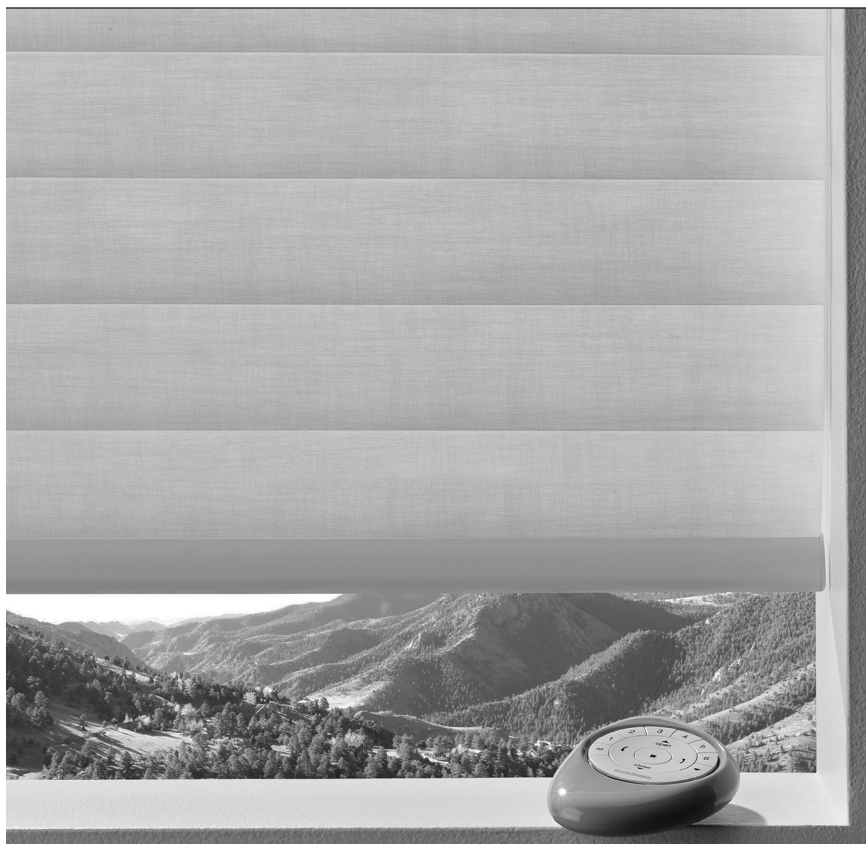

## Sonnette™ Cellular Roller Shades PowerView® Motorization

5118000018F



5/18

# CONTENTS

---

## GETTING STARTED:

Product View.....	1
Tools and Fasteners Needed .....	2

## INSTALLATION:

Installation Overview .....	3
STEP 1 — Mount the Installation Brackets .....	3
Inside Mount.....	4
Outside Mount.....	6
STEP 2 — Install the Shade.....	8
STEP 3 — Connect the Power Source .....	9

## OPERATION:

Testing the Shade .....	14
Basic Operation .....	14
Troubleshooting .....	17

## CARE:

Removing the Shade .....	23
Cleaning Procedures .....	23

## DECLARATIONS .....

25

## WARRANTY .....

Back Cover

---

### Questions?

Call Hunter Douglas Consumer Support at **1-800-265-8000**.

Product View

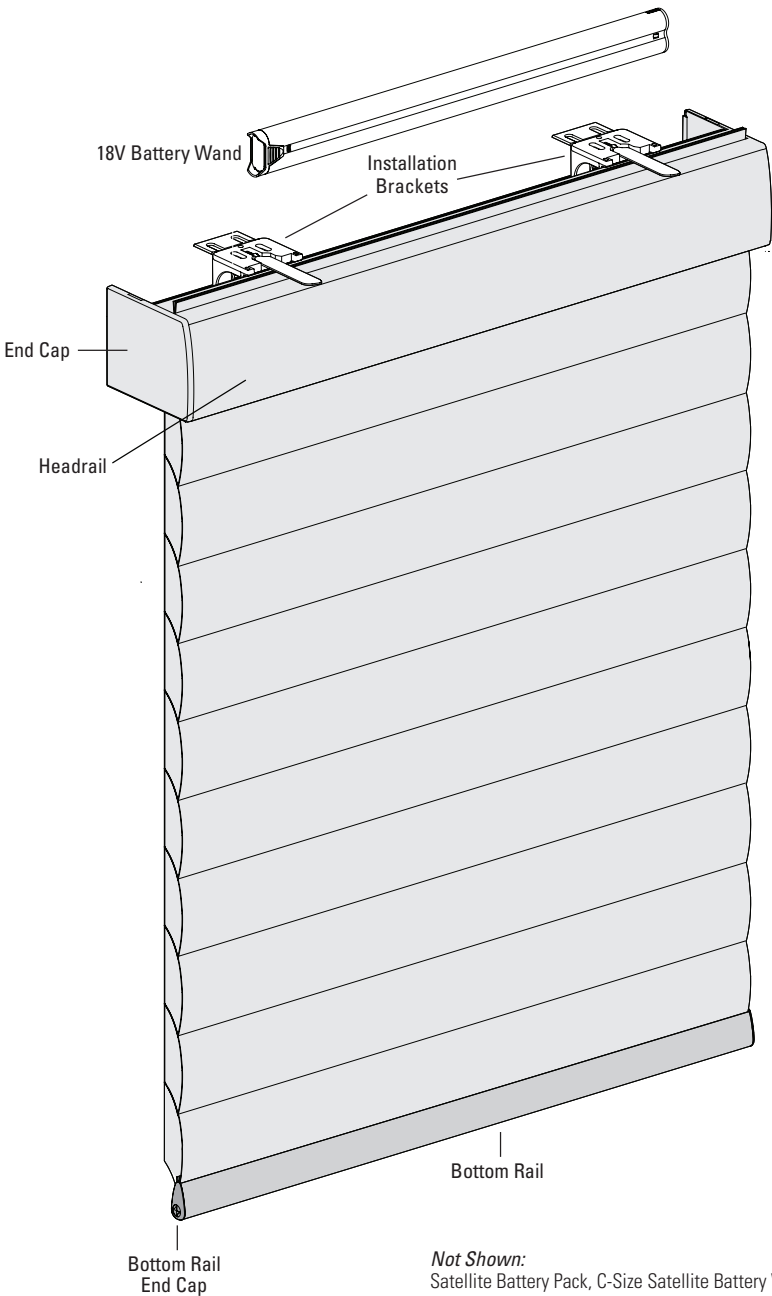

## GETTING STARTED

---

Thank you for purchasing Hunter Douglas Sonnette™ cellular roller shades with PowerView® Motorization. With proper installation, operation, and care, your new shades will provide years of beauty and performance.

Please thoroughly review this instruction booklet and the enclosed packing list before beginning the installation.

### Tools and Fasteners Needed

- Flat blade and Phillips screwdrivers
- Level (laser level is recommended)
- Measuring tape and pencil
- Pliers
- Power drill,  $\frac{3}{32}$ " drill bit, and  $\frac{1}{4}$ " hex driver
- Scissors (heavy-duty)

In addition, you will need fasteners designed to work with your specific mounting surface(s).

- **#6 Hex Head Screws (Provided).** Two  $1\frac{1}{2}$ " screws are provided per installation bracket.
- **Longer #6 Hex Head Screws (Not Provided).** If using spacer blocks, use #6 screws long enough for a secure attachment.
- **Speed Nuts and Screws (Provided).** Extension brackets come with screws and speed nuts.
- **Drywall Anchors (Not Provided).** Use drywall anchors when mounting into drywall.



#6 x 1 1/2"  
Hex Head Screw  
(Provided)



Longer #6 Hex Head Screw  
for Use with Spacer Blocks  
(Not Provided)



Speed Nut  
and Screw  
(Two Provided with  
Each Extension Bracket)

## Installation Overview

To install your shade, you will need to perform the following three steps:

**STEP 1:** Install the Brackets

**STEP 2:** Install the Shade

**STEP 3:** Connect the Power Source

### STEP 1 — Install the Brackets

- Your order will include the correct number of installation brackets for your shade width, as shown in the table below.
- Shade orders may also include spacer blocks or extension brackets, if they were specified for added clearance.

Installation Bracket

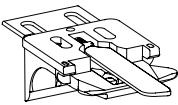

Shade Width	Brackets
15" – 36"	2
36 $\frac{1}{8}$ " – 79"	3
79 $\frac{1}{8}$ " – 84"	4

For Added Clearance

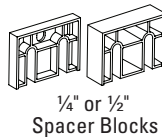

1/4" or 1/2"  
Spacer Blocks

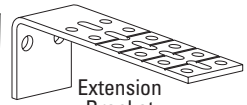

Extension  
Bracket

### Mounting Types and Window Terminology

If the installation brackets are mounted correctly, the rest of the installation process follows easily. To prepare for this important first step, review the mounting types and basic window terminology illustrated below.

Molding

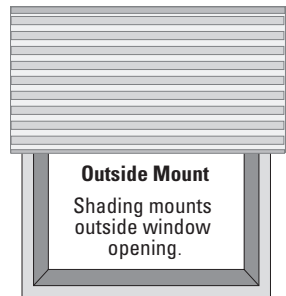
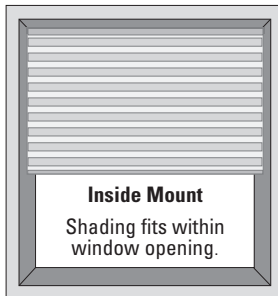
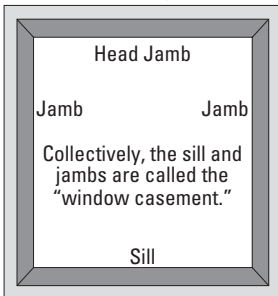

- Refer to the appropriate page below based on your order:

➤ **Inside Mount — Page 4**

➤ **Outside Mount — Page 6**

# INSTALLATION

## Mount the Installation Brackets — Inside Mount

### Prepare the Installation Brackets

- Use pliers or heavy duty scissors to remove the top tabs on the installation brackets.

**NOTE:** Save these tabs once removed. They may be used as shims, if necessary.

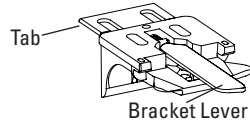

### Mount the Installation Brackets

- Mark 2" to 3" from each jamb for bracket location.
  - If more than two installation brackets came with your order, space additional bracket(s) evenly between the two end brackets and mark their location. Mount into wood whenever possible.

**NOTE:** Before the headrail is installed, the bracket levers need to be fully to the left and once the headrail is properly in place, levers click to the right.

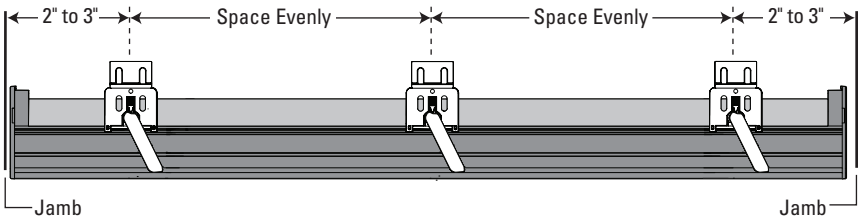

- Centre the brackets on your marks and mark the location of the screw holes.

- The minimum casement depth required for installation brackets is 1".
- The minimum casement depth required for a fully recessed mount is  $3\frac{3}{16}$ ".

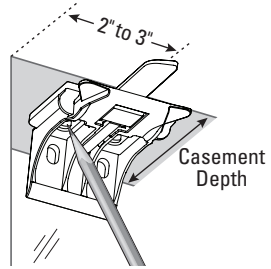

- Use a level to check that the mounting surface is level. Shim the brackets, if necessary (use the top tab that was removed from the brackets).

- Drill the screw holes using a  $\frac{3}{32}$ " drill bit.

**CAUTION:** Use drywall anchors when mounting into drywall.

- Attach the installation brackets using the screws provided.

**IMPORTANT:** Do not overtighten the screws. Check to ensure the bracket lever can be moved easily side to side. If not, loosen the screws in one-eighth turn increments until the lever can be moved easily.

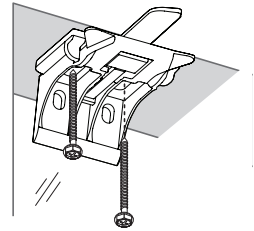

**IMPORTANT:** The front edges of the installation brackets must be level and aligned to each other.

Proceed to "Install the Shade" on page 8.

# INSTALLATION

## Mount the Installation Brackets – Outside Mount

### Prepare the Installation Brackets

- Use pliers or heavy duty scissors to remove the top tabs on the installation brackets.

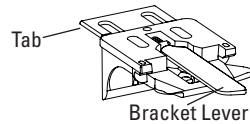

**NOTE:** Save these tabs once removed. They may be used as shims, if necessary.

### Mount the Installation Brackets

- Centre the headrail over the window opening at the desired height. Use a pencil to lightly mark the mounting surface at each end of the headrail.
  - Alternatively, measure the width of the headrail and use that width to mark the headrail end points over the window opening.
- Mark 2" to 3" from each end of the headrail.
  - If more than two installation brackets came with your order, space additional bracket(s) evenly between the two end brackets and mark their location. Mount into wood whenever possible.

**NOTE:** Before the headrail is installed, the bracket levers need to be fully to the left and once the headrail is properly in place, levers click to the right.

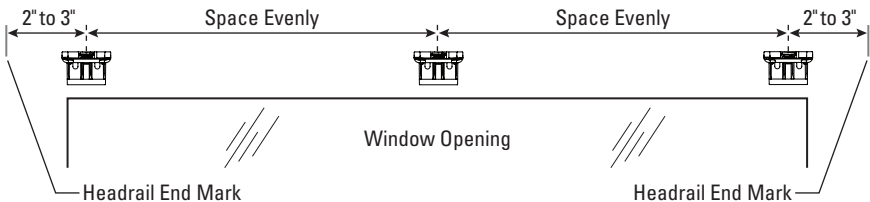

- Centre the installation brackets or extension brackets on your marks and mark where to drill the screw holes.
  - A minimum 1 1/8" flat vertical surface is required for the installation brackets. Extension brackets require 1 1/4".
  - The top of the installation brackets or extension brackets should be at the desired height. The brackets should be level and aligned to each other.

**CAUTION:** The rear of the brackets must be flush against a flat mounting surface. Do not mount brackets on curved molding.

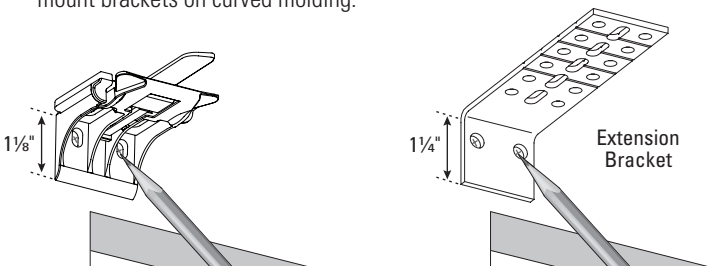



- Drill the screw holes using a  $\frac{3}{32}$ " drill bit.

**CAUTION:** Use drywall anchors when mounting into drywall.

- Attach the installation or extension brackets using the screws provided.

**IMPORTANT:** The top of the installation brackets or extension brackets must be level with their front edges aligned.

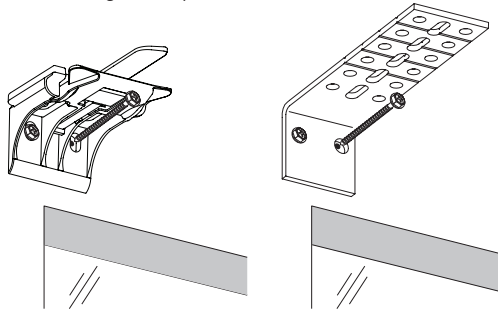

- If using spacer blocks, attach the spacer block(s) and installation bracket to a flat vertical mounting surface with #6 screws long enough for a secure installation.

➤ The top of the spacer blocks should be at the desired shade height.

**IMPORTANT:** Do not add more than  $1\frac{1}{2}$ " of clearance using spacer blocks.

**IMPORTANT:** The tops of the installation brackets must be level with the front edges aligned.

**CAUTION:** Use drywall anchors when mounting into drywall.

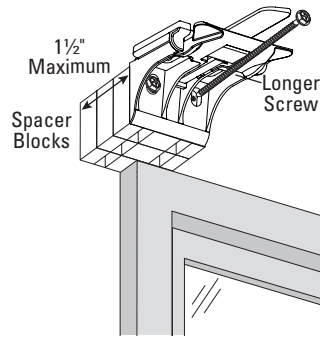

- If using extension brackets, attach an installation bracket to the underside of each extension bracket using the speed nuts and screws provided.

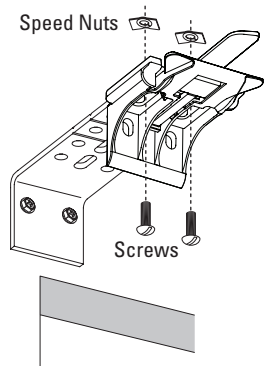

Proceed to "Install the Shade" on page 8.

# INSTALLATION

## STEP 2 – Install the Shade

- Position the shade so that the front faces you.
- Ensure that each lever is pushed to the left side of the bracket before installing the shade.
- Slide the headrail into the installation brackets so that the headrail is between the lever and the bracket, as shown.
- Firmly push the headrail into each bracket until it clicks and the levers snap to the right side of the bracket.

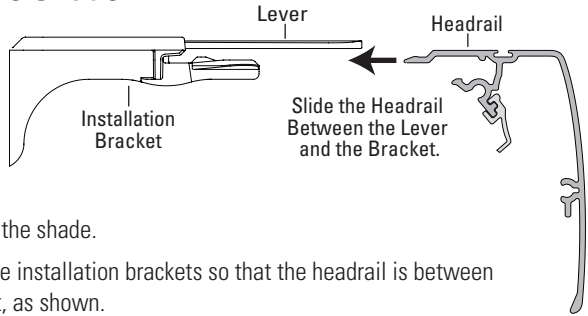

**IMPORTANT:** Carefully pull on the headrail at each bracket to ensure it is installed securely.

## Attach the Dust Cover (Optional for Outside Mounts)

The dust cover is used to protect the top of the headrail from exposure on outside mounted shades.

- Cut the dust cover to desired width.
- Remove the paper backing on one side of the hook and loop fastener dots.
- Apply the dots to the installation brackets on each end of the shades.

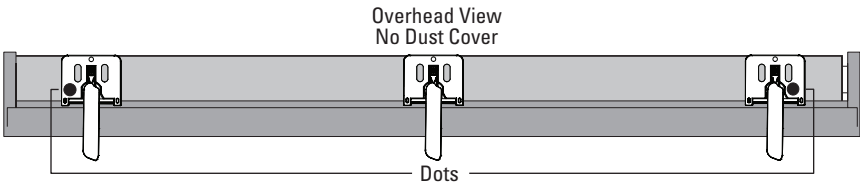

- Remove the remaining paper backing from the dots.
- Centre the dust cover over the top of the shade, above the dots.
- Press the dust cover down onto the dots.

Dust Cover Installed

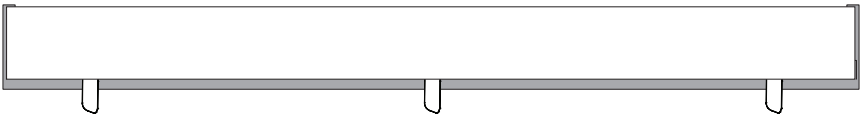

## STEP 3 — Connect the Power Source

**NOTE:** When power is connected to the motor, a green LED inside the manual control button housing will flash to indicate the shade is ready for operation.

- Refer to the appropriate page based on your order.
  - For a battery wand, see below.
  - For an optional satellite battery pack, see page 11.
  - For an optional 18V DC power supply, see page 12.
  - For an optional 18V DC power supply with daisy-chain connections, see page 13.
  - For an optional C-size satellite battery wand or large DC power supply, see the instructions that came with the unit.

### If You Have a Battery Wand...

#### Install the Batteries into the Battery Wand

**NOTE:** Hunter Douglas recommends AA alkaline batteries for use with our battery-powered shades. These will provide approximately one year of operation, depending on usage. Lithium and rechargeable batteries are not recommended.

- Squeeze the cap latch to release the cap.
- Remove the cap from the battery wand.
- Install the batteries according to the instructions on the battery wand label.
- Replace the cap.
  - Align the tab with the slot on the end of the wand.
  - Press the cap on until it latches.

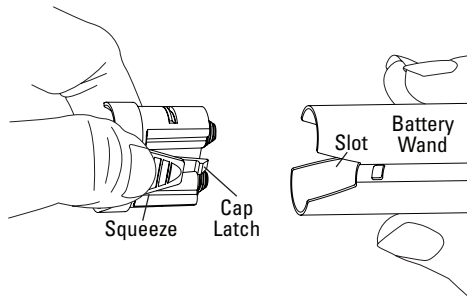

# INSTALLATION

---

## Install the Battery Wand

**NOTE:** Battery wand is stored in the front of the headrail. Reference the label on the front of the headrail for location.

- Plug the power cable into the battery wand.
- Lower the shade at least 12" in order to create space to install the battery wand.
- Locate the clips inside the headrail in front of the fabric roll, as shown.
- To install, place the wand against the inside of the front of the headrail then push up until the battery wand locks into place and clicks.

**NOTE:** Listen for a "click" when installing the battery wand to make sure it is inserted all the way into the clips.

**NOTE:** To remove the battery wand, reach your fingers inside the front of the headrail where the battery wand is located. Find the lip on the end of the wand and pull down.

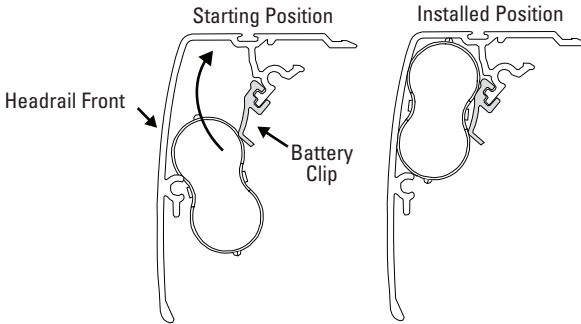

---

Proceed to "Testing the Shade" on page 14.

---

## If You Have a Satellite Battery Pack...

### Install Batteries into the Battery Wand

- See the instructions on page 9.

### Mount the Satellite Battery Pack

- Decide where you want to mount the satellite battery pack. A satellite battery pack may be mounted in any orientation.
- Mark the screw holes for the wall mount bracket.
- Drill the screw holes using a  $\frac{3}{32}$ " drill bit.
- Remove the backing from the double-sided tape. Press the bracket into place.
- Attach the bracket using the screws provided.
- Position the battery wand so the power cable is easily connected to the socket.
- Snap the battery wand into the wall mount bracket.

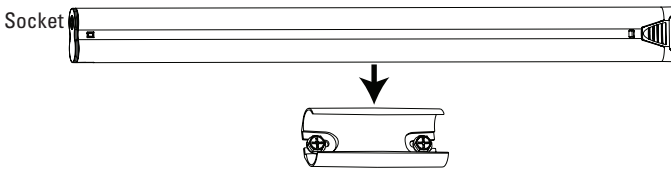
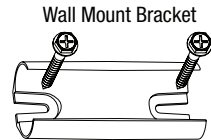

- Install the battery wand cover with the slot aligned to the socket in the battery wand.

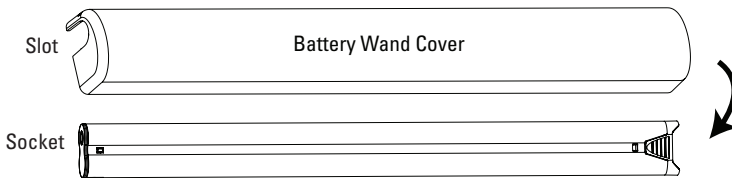

- Plug the power cable from the shade into the extension cable.
- Plug the other end of the extension cable into the socket in the battery wand.
- Secure the power supply using wire retainers (not supplied).

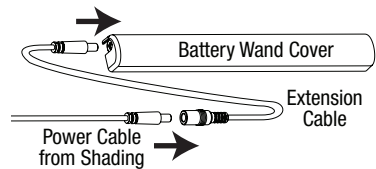

Proceed to "Testing the Shade" on page 14.

# INSTALLATION

## If You Have an 18V DC Power Supply...

### Connect the Power Supply

- Plug the power cable from the shade into the extension cable.
- Plug the other end of the extension cable into the 18V DC power supply.
- Plug the 18V DC power supply into a standard outlet.
- Secure the extension cable using wire retainers (not supplied). If hiding the cable behind the shade, make sure it does not impede the operation of the shade.
- Space the wire retainers approximately 15" apart along the power supply cable, as shown.



**WARNING:** Keep cables and small parts out of the reach of children. They can wrap cables around their necks and

**STRANGLE.** They can also put small parts in their mouths and **CHOKE.**



**WARNING:** Electric shock and/or a fire hazard may occur, if not properly installed.

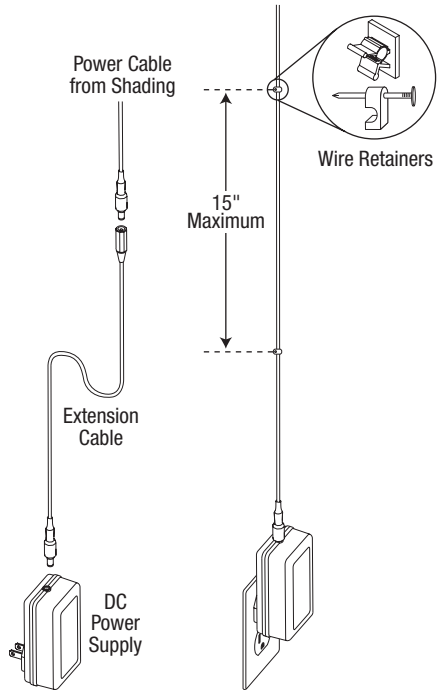

Proceed to "Testing the Shade" on page 14.

## If You Have an 18V DC Power Supply with Daisy-Chain Connections...

The daisy-chain feature allows up to three PowerView® shades to be powered by a single 18V DC power supply. However, each shade can operate independently. The daisy-chain feature is only available with the 18V DC power supply option.

- Route the power cable from each shade to the connector, using an extension cable, if necessary.
- Plug an extension cable into the connector and plug the cable into the 18V DC power supply. Two extension cables and two connectors are used for three shades.

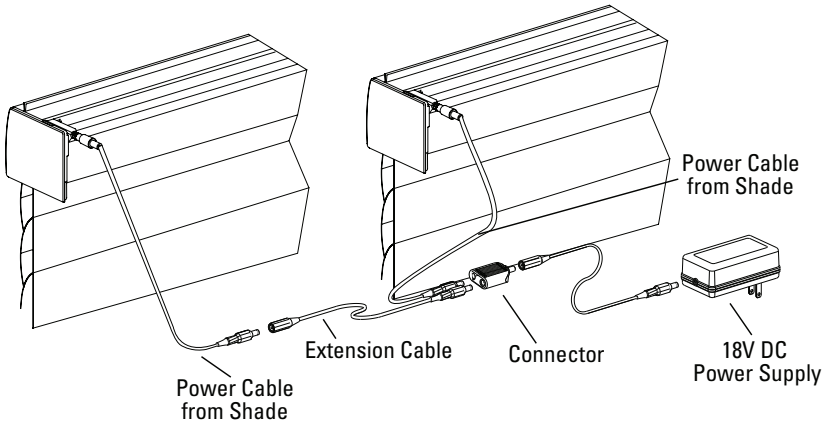

- Plug the 18V DC power supply into a standard outlet.

Proceed to “Testing the Shade” on page 14.

## OPERATION

### Testing the Shade

Use the manual control button to test the shade and ensure that the motor and power source are working correctly.

- Press the manual control button to lower the shade. If the shade does not operate, see “Troubleshooting” on page 17.
- Press the manual control button to raise the shade.

**CAUTION:** When raising the shade for the first time, observe how the fabric rolls up into the headrail. It should roll up evenly. If the bottom rail is not level or the shade starts to rub against either window jamb, immediately press the manual control button to stop the shade. See “Adjusting the Bottom Rail Weight” on page 22.

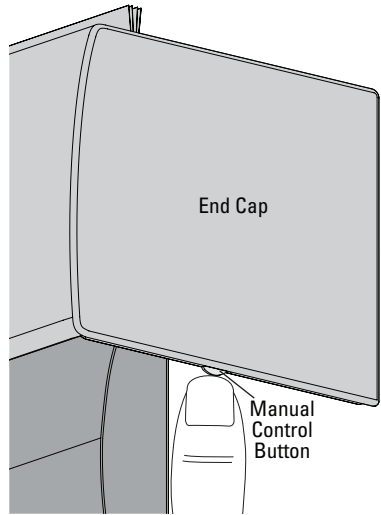

### Using the PowerView® Remote

First, activate the remote by pulling both plastic tabs from the back battery compartment.

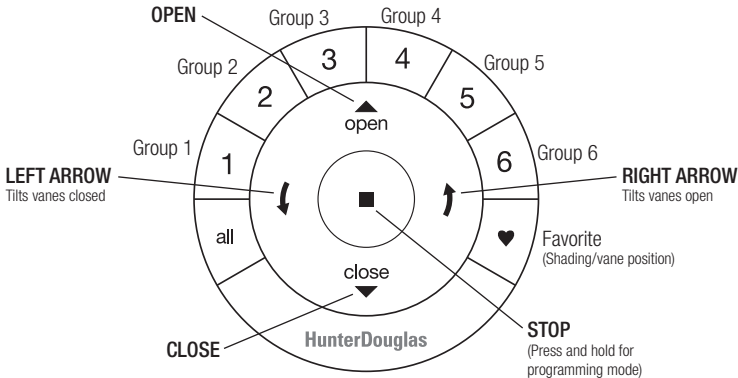

**IMPORTANT:** If you have more than one remote, see “Adding Additional Remote(s) to the PowerView® Shade Network” in the *PowerView Motorization Remote Control Guide*.



## **Joining a Shade to a Group**

**IMPORTANT:** The shade will not operate using the remote until it has been joined to a group.

1. Press and hold ■ STOP for 4 seconds to put the remote in program mode. The lights on the remote will flash to indicate it is in program mode.
2. Press the desired group number (1 – 6) on the remote. The backlight for the group number will flash to show it is selected.
3. Press and hold the manual control button on the shade.
4. While continuing to press the manual button, press ▲ OPEN on the remote. The shade will move slightly to indicate it has joined the group. Release the manual control button.
5. Press and hold ■ STOP for 4 seconds to exit program mode. The lights will stop flashing.

## **Basic Operation**

1. To wake up the remote, simply pick it up or press ■ STOP. The last group(s) selected will be highlighted and active.
2. Press “all” or groups 1 – 6 to select specific shade(s) to move. Selected group button(s) will light to show they are selected.
  - a. Multiple group buttons may be selected at a time.
  - b. To deselect a group, press the group button again. The backlight for that group button will go out.
3. Press ▼ CLOSE to lower the selected shade(s).
4. Press ▲ OPEN to raise the selected shade(s).
5. Press ■ STOP to stop shade or vane movement anywhere along its travel.
6. While a shade is in motion, press the opposite of shade motion (▲ OPEN or ▼ CLOSE) to reverse direction.
7. Press ♥ FAVORITE to send selected shade(s) to your preset “favorite” position. Refer to the *PowerView® Motorization Remote Control Guide* on how to set a favorite position.

## **Operating Tips**

1. When the shade is raised, pressing the ▼ CLOSED arrow will first lower the shade.
2. When the shade is lowered, pressing the ▲ OPEN will the raise the shade all the way.

# OPERATION

---

## **Further Operation and Programming Information**

---

### **PowerView® Pebble® Remote and/or PowerView Surface Remote Operation**

For information regarding operation and programming of the PowerView remote, refer to your *PowerView Motorization Remote Control Guide*.

### **PowerView Scene Controller**

For information regarding operation and programming of the PowerView Scene Controller, refer to your *PowerView Motorization Scene Controller Guide*.

### **PowerView App Operation**

The PowerView Hub is required for PowerView App operation. For information regarding setup and operation using the PowerView App, refer to the online *PowerView App Software Guide* at [hunterdouglas.com/powerview/support](http://hunterdouglas.com/powerview/support).

## **Resetting the Shade (If Necessary)**

### **Basic Reset**

The basic reset is used to reset the shade's travel limits.

1. Press and hold the manual control button for 6 seconds. The shade will move slightly.
2. Release the manual control button. The shade will raise to its fully open position to set the upper travel limit, then lower to the fully closed position to set the lower travel limit. The shade will move slightly one more time to indicate that the travel limits have been reset.

### **Resetting Shade Programming**

This reset erases all shade programming from memory, including group assignments, preventing any input device from operating the shade. Its primary use is during installation to correct group and network assignments. This reset does not affect travel limits.

1. Press and hold the manual control button for 12 seconds. The shade will move slightly after 6 seconds, then again after 12 seconds. Release the button.
2. Refer to "Joining a Shade to a Group" on page 15 to program the shade to a group.

## Troubleshooting

If your shade is not operating correctly:

- First review the guide that came with your control device.
- Refer to the following troubleshooting procedures for specific solutions for your shade.

If questions remain, please contact Hunter Douglas Consumer Support at **1-800-265-8000**.

<b>Problem</b>	The shade will not fit into the installation brackets.
<b>Solution</b>	<p>Check that the installation brackets are level and aligned. Adjust and/or shim to level, if necessary.</p> <p>Check that the headrail is completely inserted into the installation brackets. See "STEP 2 — Install the Shade" on page 8.</p>
<b>Problem</b>	The shade is hard to raise or lower, or will not raise or lower.
<b>Solution</b>	<p>Shades cannot be forced into tight inside mount window openings. If an inside mount, make sure there is clearance between the ends of the shade and the window casement.</p> <p>Check that the installation brackets are level. Shim to level, if necessary.</p>
<b>Problem</b>	The shade does not operate using the manual control button.
<b>Solution</b>	<p>Unplug the power cable from the motor, then plug it back in. An LED inside the manual control button housing should flash GREEN 4 times to indicate the motor has power.</p> <p>Check that the batteries in the battery wand, satellite battery pack, or C-size satellite battery wand are correctly inserted and fresh.</p> <p>Check that the battery wand, satellite battery pack, C-size satellite battery wand, or 18V DC power supply is securely connected to the power cable and the cables are not pinched or caught in the headrail or installation brackets.</p>
<b>Problem</b>	The shade is not responding to the PowerView® remote.
<b>Solution</b>	<p><b>IMPORTANT:</b> A shade will not operate using the remote until it has been joined to a group</p> <p>Check that the correct group number is selected.</p> <p>Check that the batteries in the remote are correctly inserted and are fresh. The LEDs that backlight the remote should come on full bright when ■ STOP is pressed.</p>

# OPERATION

<b>Problem</b>	The power cord is positioned for a battery wand instead of a satellite battery pack or 18V DC power supply.
<b>Solution</b>	<p><b>Reroute the Power Cord</b></p> <p><b>NOTE:</b> The power cord is located in the front of the shade for an 18V battery wand. The Satellite Battery Pack and the 18V DC Power Supply require the power cord to be rerouted to the back of the shade.</p> <ul style="list-style-type: none"><li>■ If the shade is installed, remove the shade from the installation brackets. See "Removing the Shade" on page 23.</li><li>■ Remove the end cap cover on the control side (the side where the manual control button is located).</li><li>■ Lift the power cord up through the hole in the end cap, as shown.</li><li>■ Pull the cord toward the top of the end cap and place it in the notch at the top of the end cap, as shown.</li><li>■ Replace the end cap cover and reinstall the shade.</li></ul>

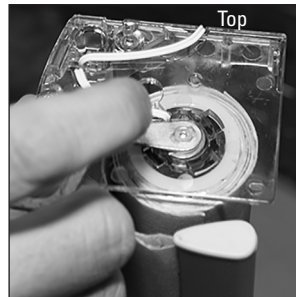
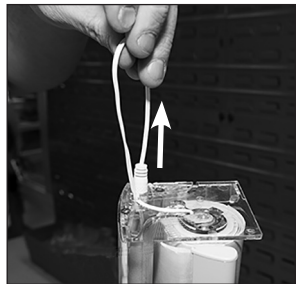

<b>Problem</b>	The bottom rail does not raise or lower completely, or its location when fully lowered has changed over time.
<b>Solution</b>	<p>The batteries may be low in the battery wand, satellite battery pack, or C-size satellite battery wand. Replace the batteries.</p> <p>Check that the battery wand, satellite battery pack, C-size satellite battery wand, or 18V DC power supply is securely connected to the power cable and the cables are not pinched or caught in the headrail or installation brackets.</p> <p>Check that there is clearance between the ends of the shade and the window casement on inside mounts.</p> <p>Check if the fabric rolls up evenly into the headrail. If not, see "Adjusting the Bottom Rail Weight" on page 22.</p> <p>Reset the travel limits. See "Adjusting the Limits" on page 20.</p> <p>See the <i>PowerView® Motorization Remote Control Guide</i> for operation or programming troubleshooting solutions.</p>
<b>Problem</b>	Cells do not align on side-by-side shades.
<b>Solution</b>	<p>Cell alignment is only guaranteed within 1/8" when shades are ordered at the same time, at the same height, with the same color and fabric, and when specified on the order form.</p> <p>Check that the windows are square and the same height.</p>
<b>Problem</b>	Adjacent shades do not roll up evenly.
<b>Solution</b>	<p>It is considered normal if the roll-up on both shades is within 5/16" of each other. If one shade rolls up tighter than another, lower and raise both shades several times.</p> <p>Reset the shade. See "Resetting the Shade (If necessary)" on page 16.</p> <p>Check that the shade fabric is not catching on any brackets or components.</p> <p>Check that the fabric winds evenly and does not rub against the headrail. If uneven, see "Adjusting the Bottom Rail Weight" on page 22.</p>

<b>Problem</b>	The shade limits need to be adjusted — upper limit.
<b>Solution</b>	<p><b>Adjusting the Limits</b></p> <p><b>Adjusting the Upper Limit</b></p> <ul style="list-style-type: none"><li>■ Move the shade to the fully open position. See “Basic Operation” on page 15.</li><li>■ De-select all group numbers on the remote by pressing all group buttons that show a backlight.</li><li>■ While the shade is at the fully open limit position press and hold the manual control button. See “Testing the Shade” on page 14.</li><li>■ While holding the manual control button press and release the ▲ OPEN button on the remote.</li><li>■ Release the manual control button. The shade's light will blink red once and the shade will move slightly to indicate the shade's upper limit is ready to be adjusted.</li><li>■ Push ▲ OPEN or ▼ CLOSE on the remote and the shade should move slowly.</li></ul> <p><b>NOTE:</b> If the shade does not move slowly, repeat the previous steps.</p> <ul style="list-style-type: none"><li>■ Push the ■ STOP button on the remote once the shade is in the desired location.</li><li>■ Press ■ STOP for 4 seconds to enter programming mode.</li><li>■ While the remote is in programming mode, press and hold the manual control button.</li><li>■ Without selecting a number, push the ▲ OPEN button. The shade should move slightly, indicating the new top limit.</li><li>■ To exit programming mode, press and hold the ■ STOP for 4 seconds.</li><li>■ Verify the new limit by moving the shade down and then up.</li></ul>

<b>Problem</b>	The shade limits need to be adjusted — lower limit.
<b>Solution</b>	<p><b><u>Adjusting the Limits (Continued)</u></b></p> <p><b>Adjusting the Lower Limit</b></p> <ul style="list-style-type: none"> <li>■ Move the shade to the fully closed position. See “Basic Operation” on page 15.</li> <li>■ De-select all group numbers on the remote by pressing all group buttons that show a backlight.</li> <li>■ While the shade is at the fully closed limit position press and hold the manual control button. See “Testing the Shade” on page 14.</li> <li>■ While holding the manual control button press and release the ▼ CLOSE button on the remote.</li> <li>■ Release the manual control button. The shade's light will blink red once and the shade will move to indicate the shade's lower limit is ready to be adjusted.</li> <li>■ Push ▲ OPEN or ▼ CLOSE on the remote and the shade should move slowly.</li> </ul> <p><b>NOTE:</b> If the shade does not move slowly, repeat the previous steps.</p> <ul style="list-style-type: none"> <li>■ Press ■ STOP for 4 seconds to enter programming mode.</li> <li>■ While the remote is in programming mode, press and hold the manual control button.</li> <li>■ Without selecting a number, push the ▼ CLOSE button. The shade should move slightly, indicating the new bottom limit.</li> <li>■ To exit programming mode, press and hold the ■ STOP for 4 seconds.</li> <li>■ Verify the new limit by moving the shade up and then down.</li> </ul>

## OPERATION

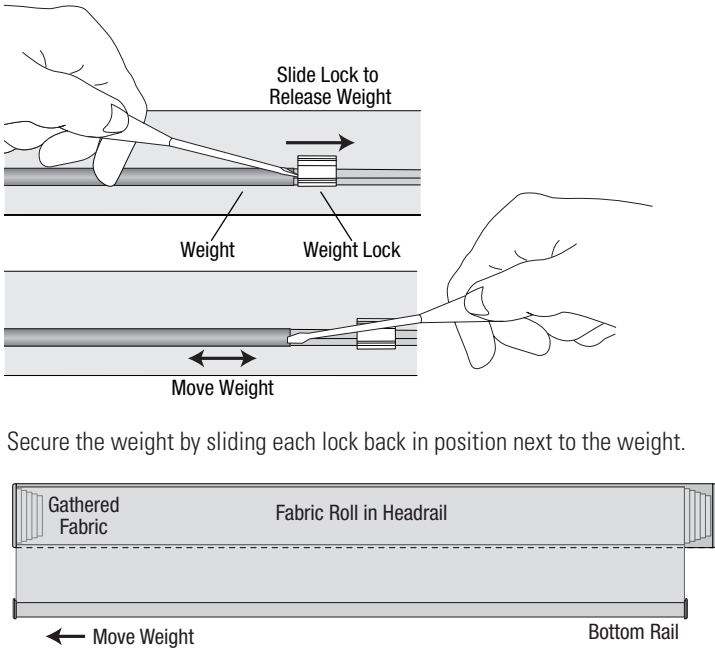
<b>Problem</b>	The shade raises or lowers unevenly, the bottom rail is not level when fully raised, or the fabric winds unevenly, or starts to rub against one end of the headrail.
<b>Solution</b>	<p>Keep the bottom rail level while raising the shade. Side-to-side movement while raising the shade may cause fabric to skew.</p> <p>Check that the window is square by measuring the diagonals.</p> <p>Check that the installation brackets are level. Shim to level, if necessary.</p> <p>If the headrail is level and the window is square, adjust the bottom rail weight.</p> <h3>Adjusting the Bottom Rail Weight</h3> <p><b>IMPORTANT:</b> Only adjust the bottom rail weight if the fabric does not roll up straight into the headrail.</p> <p>First, release both weight locks. On the back of the bottom rail, insert a flat-blade screwdriver into the slot in each weight lock and slide them away from the weight.</p> <p>Slide the weight, in 1" increments, in the direction the fabric is gathering.</p>  <p>Secure the weight by sliding each lock back in position next to the weight.</p> <p>Test and adjust again, if necessary.</p>



## Removing the Shade

- Fully raise the shade.
- Disconnect the power source from the power cable at the back of the shade.
- Move each lever of the installation brackets to the left to release the shade.

➤ A flat blade screwdriver can be used to move the lever.

**CAUTION:** Be very careful not to tear or damage the fabric.

- If the lever is inaccessible or inoperable, lower the shade until you can see the underside of the bracket. Carefully reach a small flat blade screwdriver behind the shade to the tab on bottom of the bracket between the screw holes.
- Push the tab away from the shade and pull the headrail to release it from the bracket.

- Carefully pull the shade to remove it from the brackets.

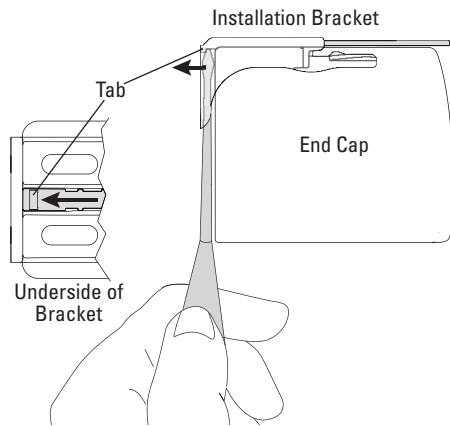
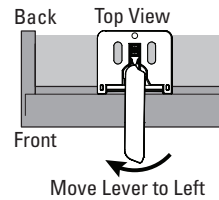

## Cleaning Procedures

Sonnette™ Cellular roller shades are made from anti-static, dust-resistant materials which repel dirt and dust. The following options are available if your shade needs cleaning.

**CAUTION:** Do not steam the shades.

### Dusting

- Regular light dusting with a feather duster is all the cleaning needed in most circumstances.

### Vacuuming

- Use a hand-held vacuum with low suction for more thorough dust removal.

### Compressed Air

- Use compressed air to blow dust and dirt off shades.

## CARE

---

### **Spot-Cleaning**

**CAUTION:** Do not use spot clean treatment on Highline™, Textura™, and Elan® Metallic fabrics.

- Prepare a solution of warm water and a mild detergent.
- Dampen a clean cloth in the solution and wring it out.
- Dab the spot with the dampened cloth until it is removed. Do not rub the fabric.
- Allow the shade to dry in the completely lowered position.

### **Bathtub Cleaning/Water Immersion**

**CAUTION:** Do not immerse the hardware, Elan Metallic, or room-darkening fabrics.

- Immerse the shade in a basin or bathtub filled with warm water and a mild detergent.  
**IMPORTANT:** Never immerse the headrail into the solution.
- Rinse with clean water.
- Before removing from the rinse water, fully raise the shade and tilt it to allow excess water to drain off.
- Dry the shade completely in the lowered position.

### **Injection/Extraction Cleaning**

**CAUTION:** Do not use injection/extraction cleaning on Elan Metallic fabric.

This type of professional cleaning injects a cleaning solution into the fabric and extracts the dirty solution in the same motion.

### **A Note About Sonnette™ Fabrics**

As with all textiles, Sonnette™ fabric is subject to some variation. Slight wrinkling, puckering, or bowing is inherent to this textile product and should be considered normal, acceptable quality. These characteristics are not usually visible from the front or rear but may be visible from a side angle.

## **U.S. Radio Frequency FCC Compliance**

*FCC ID information is located underneath the right side end cap.*

This device complies with Part 15 of the FCC Rules. Operation is subject to the following two conditions:

- (1) This device may not cause harmful interference, and
- (2) This device must accept any interference received, including interference that may cause undesired operation.

This equipment has been tested and found to comply with the limits for a Class B digital device, pursuant to Part 15 of the FCC Rules. These limits are designed to provide reasonable protection against harmful interference in a residential installation. This equipment generates, uses and can radiate radio frequency energy and, if not installed and used in accordance with the instructions, may cause harmful interference to radio communications. However, there is no guarantee that interference will not occur in a particular installation. If this equipment does cause harmful interference to radio or television reception, which can be determined by turning the equipment off and on, the user is encouraged to try to correct the interference by one or more of the following measures:

- Reorient or relocate the receiving antenna.
- Increase the separation between the equipment and receiver.
- Connect the equipment into an outlet on a circuit different from that to which the receiver is connected.
- Consult the dealer or an experienced radio/TV technician for help.

*Any changes or modifications not expressly approved by the party responsible for compliance could void the user's authority to operate the equipment.*

This equipment complies with FCC radiation exposure limits set forth for an uncontrolled environment and meets the FCC radio frequency (RF) Exposure Guidelines. This equipment should be installed and operated keeping the radiator at least 20 cm or more away from person's body. RF Exposure requirements are met when installed in mobile equipment. This module cannot be installed in portable equipment without further testing and a change to FCC's grant of authorization.

---

## **Industry Canada**

Under Industry Canada regulations, this radio transmitter may only operate using an antenna of a type and maximum (or lesser) gain approved for the transmitter by Industry Canada. To reduce potential radio interference to other users, the antenna type and its gain should be so chosen that the equivalent isotropically radiated power (e.i.r.p.) is not more than that necessary for successful communication.

This device complies with Industry Canada licence-exempt RSS standard(s). Operation is subject to the following two conditions: (1) this device may not cause interference, and (2) this device must accept any interference, including interference that may cause undesired operation of the device.

### **Class B Digital Device Notice**

This Class B digital apparatus complies with Canadian ICES-003, RSS-Gen and RSS-210.

CAN ICES-3 (B)/NMB-3(B)

This equipment complies with IC radiation exposure limits set forth for an uncontrolled environment and meets RSS-102 of the IC radio frequency (RF) Exposure rules. This equipment should be installed and operated keeping the radiator at least 20 cm or more away from person's body.

---

## **European Conformity**

We, the undersigned,

Hunter Douglas Window Fashions

One Duette Way, Broomfield, CO 80020, USA

Hunter Douglas Europe B.V.

Piekstraat 2, 3071 EL Rotterdam, The Netherlands

certify and declare under our sole responsibility that assembly PV9 conforms with the essential requirements of the EMC directive 2004/108/EC and R&TTE directive 1999/5/EC.

A copy of the original declaration of conformity may be found at:

**[www.hunterdouglas.com/RFcertifications](http://www.hunterdouglas.com/RFcertifications)**.



## Lifetime Limited Warranty

### GUARANTEE

The Hunter Douglas® Guarantee is designed to ensure a thoroughly satisfying experience when selecting, purchasing and living with your window fashion products. If you are not thoroughly satisfied with our product, simply contact Hunter Douglas Canada LP at 1-800-265-8000 in Brampton or visit [hunterdouglas.ca](http://hunterdouglas.ca). In support of this policy of consumer satisfaction, Hunter Douglas Canada LP offers the following Lifetime Limited Warranty.\*

#### COVERED

BY A LIFETIME LIMITED WARRANTY\*

- Hunter Douglas window fashion products are covered for defects in materials, workmanship or failure to operate for as long as the original retail purchaser owns the product (unless shorter periods are provided below)
- All internal mechanisms
- Components and brackets
- Fabric delamination
- Operational cords are covered for 7 years from the date of purchase
- Hunter Douglas motorization components are covered for 5 years from the date of purchase
- Repairs and/or replacements will be made with like or similar parts or products

Hunter Douglas Canada LP will repair or replace the window fashion product or components found to be defective.

#### NOT COVERED

BY A LIFETIME LIMITED WARRANTY\*

- Any conditions caused by normal wear and tear
- Abuse, accidents, misuse or alterations to the product
- Exposure to the elements (sun damage, wind, water/moisture) or discolouration or fading over time
- Failure to follow our instructions with respect to measurement, proper installation, cleaning or maintenance
- Shipping charges, cost of removal and reinstallation

#### TO OBTAIN WARRANTY SERVICE

1. Contact your original dealer (place of purchase) for warranty assistance.
2. Visit [hunterdouglas.ca](http://hunterdouglas.ca) for frequently asked questions and access to service locations.
3. Contact Hunter Douglas Canada LP at 1-800-265-8000 in Brampton for technical support, certain parts free of charge, for assistance in obtaining warranty service or for further explanation of our warranty.

**\*Note: You may have different or additional rights under provincial or territorial law.**

Except where provincial or territorial law requires otherwise, Hunter Douglas Canada LP and its affiliates:

- will not be able to refund any amount paid by the purchaser to the Hunter Douglas dealer; and
- will not be liable or responsible for any economic loss, expense or fee, damage to property, personal injury, or any other damage or injury of any kind, including punitive damages, (whether or not suffered by the purchaser or other persons) arising out of or related to the design, manufacture, fabrication, distribution, purchase, installation, use, repair or replacement of the Hunter Douglas window fashion product

The limitations of liability in this Lifetime Limited Warranty shall apply regardless of whether Hunter Douglas Canada LP or its affiliates have breached a warranty or condition of sale, have been negligent in any way, or have committed any other wrong, whatsoever, except as a result of gross negligence or gross recklessness.

Different warranty periods and terms apply for commercial products and applications.

© 2010 Hunter Douglas ® Registered trademark of Hunter Douglas

Go to the online Reference Guide at [hunterdouglas.ca/traderesources](http://hunterdouglas.ca/traderesources) for the most up-to-date information. Effective 5/4/10

# HunterDouglas

[hunterdouglas.ca](http://hunterdouglas.ca)