

TCX51 Professional Tire Changer

Conventional Tire Changer with Bead Press Arm

NEW!



HUNTER
Engineering Company

Key features of the TCX51 Tire Changer

Heavyweight

- ✓ Heaviest model in its class
- ✓ Long service life

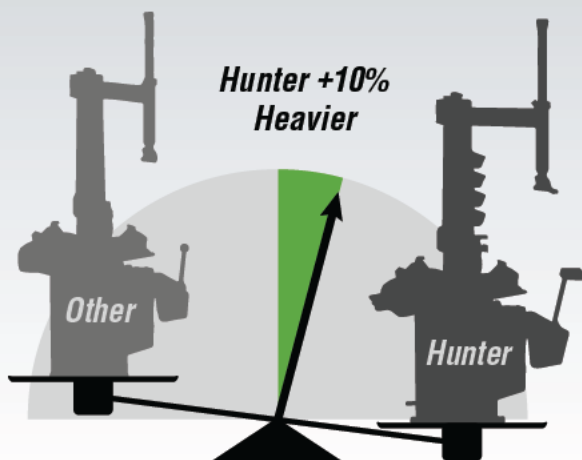

Class-Leading Rigidity

- ✓ Rigid chassis reduces damage risk and operator effort

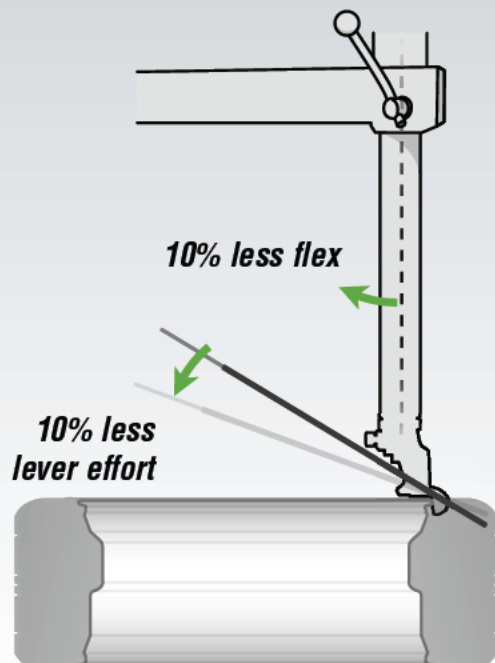

Easy-to-Use Adjustable Tabletop

NEW!

- ✓ Built-in adjustment system provides 10- to 26-in. clamping range
- ✓ All jaws adjust simultaneously for mistake-free clamping
- ✓ Polished tabletop for easy cleanup
- ✓ Hi-grip jaw covers add mounting torque and protect wheels
- ✓ Diameter marks aid external clamping

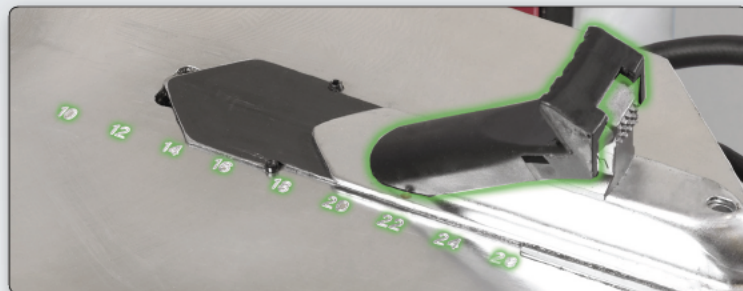

*TCX51 Professional
model features a helpful
bead press arm*



TCX51E shown

Conventional Configuration

- ✓ Polymer head for mounting and demounting
- ✓ Steel head with polymer insert for wheel protection



or

Leverless Configuration

- ✓ Locks diameter at any position, hand-screw adjustments optional
- ✓ Tapered design works with raised-spoke rims
- ✓ Lifts bead without use of levers



Coming Soon!

More Torque, More Speed

More Torque

- ✓ Unique 110V or 220V* motor generates more torque than popular air or electric models.

*110V  or 220V  configured at installation.

Faster

- ✓ Faster than popular alternatives — increases productivity
- ✓ Electric tabletop doesn't slow down under load like air motors

**Hunter +20%
More Torque**

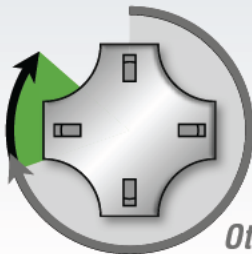

Others

**Hunter
+15%
Faster**



Others

PowerOut™ Bead Loosener

**Hunter +5%
More Force**

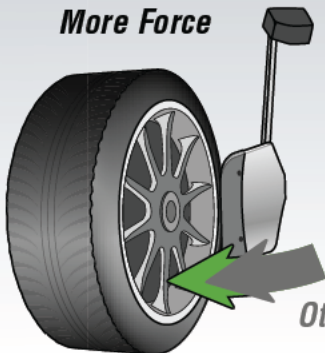

- ✓ Most powerful bead breaker in its class
- ✓ Fingertip control eases service of large assemblies
- ✓ Three-way adjustable for best rim fit
- ✓ Shovel protectors standard

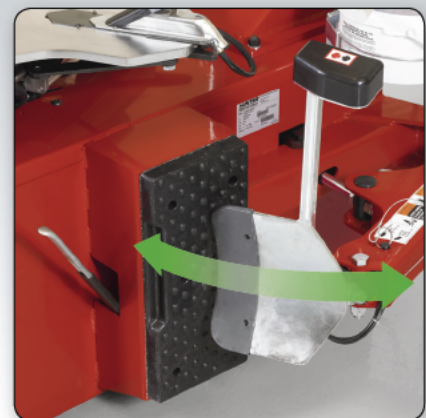

Bead press arm

- ✓ Eases clamping, demounting and mounting difficult combinations.
- ✓ Large diameter cylinder is most powerful in its class



- ✓ Press arm pushes tire into drop center for mounting and demounting operations



- ✓ Lifting hook aids the demounting of heavy tires.



- ✓ Press cone aids clamping on stiff tires.

Popular accessories

Wheel Lift

- ✓ Wheel lift eases servicing of large assemblies. Allows for more careful handling of expensive wheels. (20-2045-1)



Storage Shelf

- ✓ Convenient storage for your most used tools and accessories. (20-2885-1)



Specifications

Electrical Requirements: (110 mode) 110V, 1 ph, NEMA 5-15P

(220 mode) 220V, 1 ph, NEMA L6-20P

Air pressure operating range: 110–145 psi

Air volume of inflation tank: 4.75 gallons

Wheel Clamping (nominal)

External clamping (min-max): 10 in. – 26 in.

Internal clamping (min-max): 12 in. – 28 in.

Table rotation speed

Electronic motor: 10 CW / 10 CCW

Air motor: 10 CW / 5 CCW

Maximum tire diameter: 46 in.

Maximum tire width: 14 in.

Bead loosener width: 16 in.

Noise level: 74 dB

Machine weight: 760 lbs.

Some dimensions, capacities and specifications may vary depending on tire and wheel configurations.

TCX51 Professional Tire Changer includes:

- ✓ Bead press arm and cone
- ✓ Steel mount head with polymer inserts
- ✓ Polymer mount head
- ✓ Standard bead lever
- ✓ Bead lever protectors (polymer)
- ✓ Shovel protectors (polymer)
- ✓ Hi-grip jaw protectors (polymer)
- ✓ Inflation system
- ✓ Four storage pockets

Ordering information:

TCX51E	Electric motor
TCX51EL	Electric with leverless mount head*
TCX51A	Air motor*
20-2045-1	Add wheel lift
20-2885-1	Storage shelf

* coming soon

Because of continuing technological advancements, specifications, models and options are subject to change without notice.



0114CAP4M.52



Be sure to check out other Hunter literature for more quality products from Hunter Engineering.

HUNTER
Engineering Company

www.hunter.com