



ENG **Operator's Manual**

Read these instructions carefully and make sure you understand them before using the PP 418.

ES **Manual del operador**

Lea cuidadosamente estas instrucciones y asegúrese de que las comprende bien antes de usar el PP 418.

FR **Manuel d'utilisation**

Veillez lire attentivement ces instructions et assurez-vous de bien les comprendre avant d'utiliser la machine modèle PP 418.

PP 418

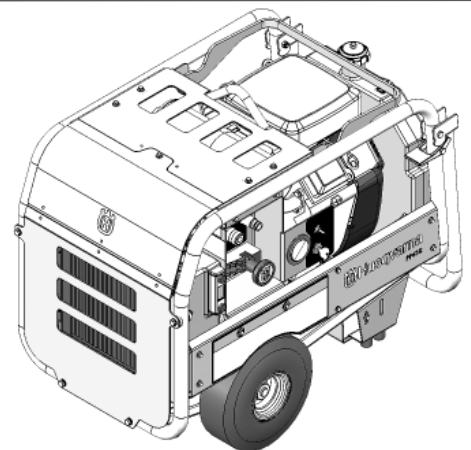

INTRODUCTION

Careless or improper use of this Power Pack can cause serious or even fatal injury.

Carefully read and understand and follow ALL instructions in this manual as well as the instructions in the included BRIGGS & STRATTON Operator's Manual before using the PP 418 Hydraulic Power Pack.

Allow only competent adults to operate this power pack. It is the owner's responsibility to ensure that all operators of this power pack have read and understand the content of this manual.

Common sense:

The focus of this manual is HOW to operate and service the equipment safely.

It is not possible to cover every conceivable situation you can face when using this equipment. Therefore use this product only in a manner described in this manual. Operation or handling the machine in any other manner can lead to serious injury or death.

If a situation is not described in this manual it should be considered dangerous - and not be done.

If you are unfamiliar with this product make sure that you carefully understand how it functions and practice all operations and handling before putting the machine to use. Familiarize yourself in the presence of an experienced operator. Avoid all situations that are beyond your capability.

If you still feel uncertain about the operating procedures after reading these instructions DO NOT operate the machine until you have consulted an experienced operator.

If you have further questions you can contact the closest Husqvarna Construction Products location by writing or calling, see information below. You can also find the closest location by searching the internet at; **www.husqvarnacp.com** . Husqvarna Construction Products will willingly be of service and provide you with advice as well as help you to use your product both efficiently and safely.

Additional manuals are available at NO CHARGE and can also be obtained on the internet site.

Husqvarna Construction Products
17400 West 119th Street
Olathe, Kansas 66061
USA

Toll Free no: 800 288 5040 (USA & Canada)
Phone no: 913 928 1000
Telefax no: 913 438 7951

Internet Site: **www.husqvarnacp.com**

PERSONAL SAFETY EQUIPMENT

When working and operating the hydraulic power pack the following approved personal safety items should be used:



Head
Protection



Hearing
Protection



Eye
Protection



Safety
Shoes



Protective
Gloves

REGISTER THE PRODUCT

Please register your new Power Pack with Husqvarna Construction Products by mailing in the registration card that came with the machine or you can register on the internet site www.husqvarnawarranty.com

Registration will allow us to contact in case of any critical updates or recalls on this machine. Warranty registration has also been found to be helpful in tracing stolen equipment.

Record the following information for your records:

PURCHASE DATE: _____

MODEL No: _____

SERIAL No: _____

ENGINE MODEL: _____ ENGINE TYPE: _____ ENGINE CODE: _____

The power pack model and serial number as well as the engine model number, engine type and code are critical in order to obtain the correct service parts. Husqvarna Construction Products does not supply any engine service parts. Engine parts are distributed through the engine manufacturer's dealer network. Please refer to the BRIGGS & STRATTON Operator's Manual that was included with the machine.

SAFETY DEFINITIONS

In this manual a Safety Alert Symbol  followed by the signal words WARNING and CAUTION are used to identify safety information about hazards which can result in death, serious injury and/or property damage.

These signal words mean:

 **WARNING** indicates a hazard which, if not avoided, **could result in death or serious injury.**

 **CAUTION** indicates a hazard which, if not avoided, **might result in minor or moderate injury.**



NOTICE indicates a message not related to personal injury.

SAFETY HAZARDS

WARNING

DO NOT MODIFY THE PRODUCT

Under no circumstances may the design of the machine be modified without the permission of the manufacturer. Always use genuine accessories. Unauthorized modifications and/or accessories can result in serious personal injury or the death of the operator or others. Your warranty may not cover damage or liability caused by the use of unauthorized accessories or replacement parts.

 WARNING	 WARNING	 CAUTION
ASPHYXIATION HAZARD Running an engine in a confined or badly ventilated area can result in injury or death due to asphyxiation or carbon monoxide poisoning.	CALIFORNIA PROP 65 Use of this product can expose you to materials known to the State of California to cause cancer and/or birth defects or other reproductive harm.	HEARING HAZARD During the normal use of this machine, operator may be exposed to a noise level equal to or higher than 85 dB(A). Use hearing protection.

CONTENTS

Content	Page
Introduction, personal safety	2
Registration of the product	3
General safety message.....	3
Table of contents	4
What is what?	5
Decals	6
What tools can be powered?.....	7
About hoses longer than 25ft (7.5m).....	7
About hydraulic couplers.....	7
Fuel and fuel safety warnings.....	8
Recommended fuels.....	8
Recommended oils	8
Assembly.....	9
How to fill the hydraulic system	9
Connecting the battery	10
Install and remove battery.....	10
Controls and operation	11
Starting.....	11
Pre-operation checklist.....	12
Starting the engine the first time.....	12
Adjusting the automatic throttle control.....	13
Engine maintenance.....	14
Hydraulic maintenance.....	15
Technical specifications.....	15
Warranty	17
Conformity certificates.....	18

LIFTING AND LOADING

Lifting and Loading the PP 418

The **Power Pack 418** weighs approx 135kg/298lb.

The safest way to move the power pack from a trailer to the work area is to hoist it using the lifting eyelet. Never attach a lifting device to any other part of the machine. Other parts are not designed to handle the weight of the power pack.

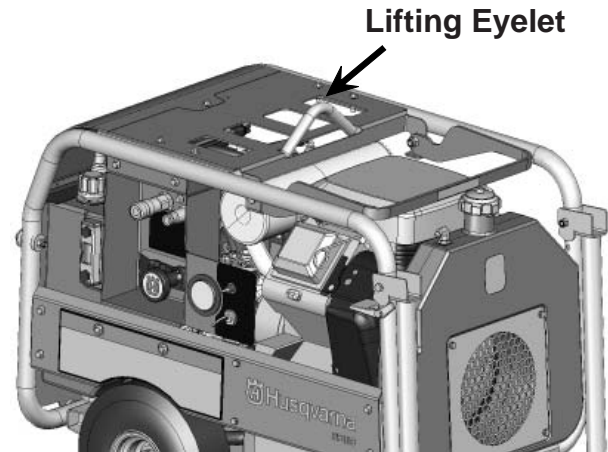

CAUTION

Only use the lifting eyelet when lifting the power pack.

If the Power Pack is to be manhandled up or down a trailer or a slope, never have anyone on the "down side" of the unit. Should the unit come loose, it could roll over anyone standing below the unit and cause injuries.

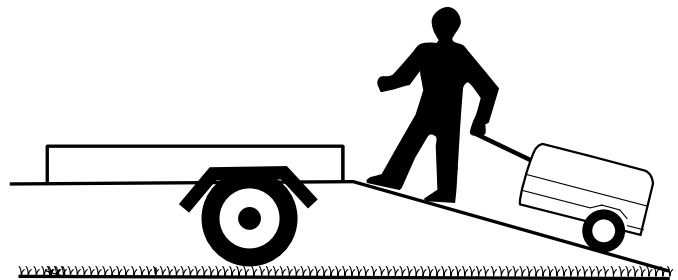

WHAT IS WHAT

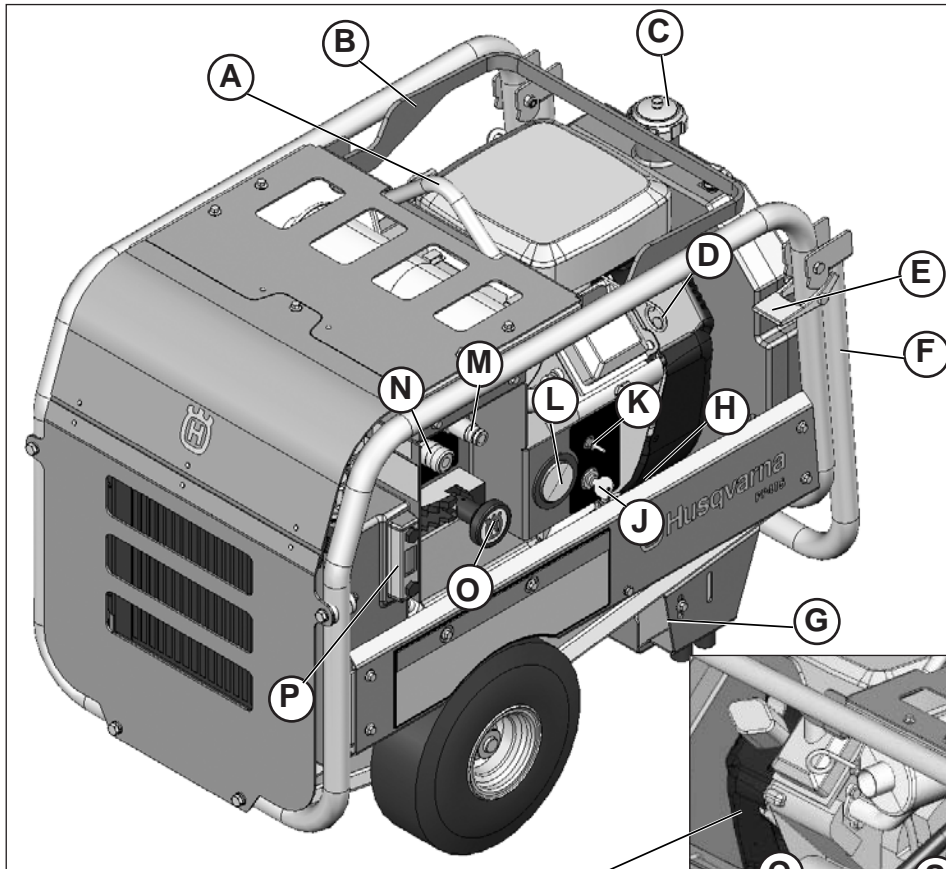

Engine model, type and code.

Power Pack model number and serial number

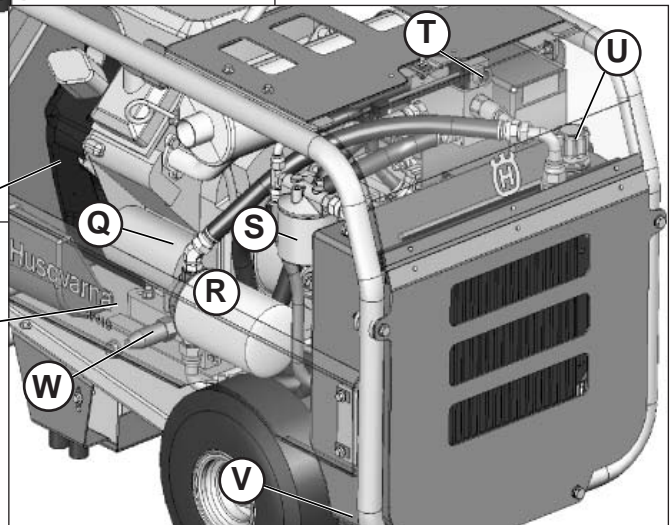

What is what?

More information on page

A. Lifting eyelet.....	4
B. Rack for hydraulic hoses	
C. Fuel gauge/fuel cap.....	8
D. Choke lever	
E. Lock for handle	
F. Transport handle	
G. Battery.....	10
H. Engine oil filter.....	14
J. Ignition switch.....	11
K. Throttle control switch	11
L. Hour meter	11
M. Pressure port.....	7
N. Return port	7
O. Flow selector	11
P. Oil temperature and oil level gauge.....	9
Q. Electric fuse, 10 Amp	
R. Large hydraulic filter.....	15
S. Small hydraulic filter	15
T. Automatic throttle adjustment.....	13
U. Hydraulic oil filler cap	
V. Hydraulic oil tank drain.....	15
W. Engine oil drain	14

DECALS AND LOCATIONS



Part number:
541 20 76-21



Part number:
542 16 90-65



Part number:
541 20 76-22

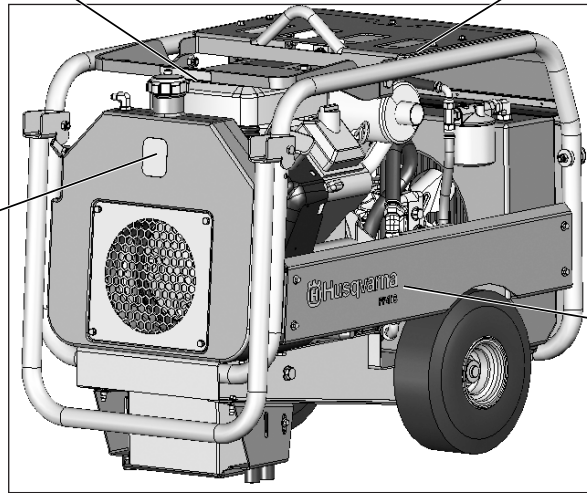

Part number:
510 04 40-01



Part number:
501 98 70-01

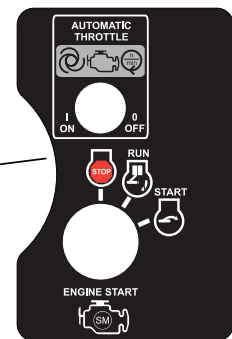
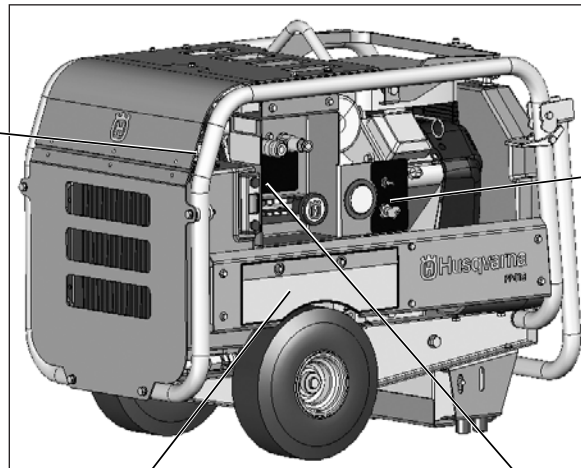

Part number:
510 19 10-01



Part number:
510 19 08-01

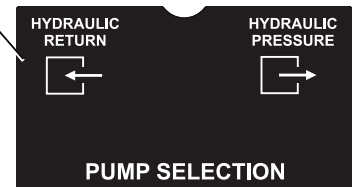

Part number:
510 19 09-01

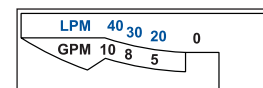

Part number:
510 19 09-02

WHAT TOOLS CAN BE POWERED

The PP 418 power pack is equipped with an adjustable flow hydraulic pump which produces hydraulic power more efficiently than a more commonly used fixed displacement gear pump.

The PP 418 power pack is suited to power any hydraulic tool with the following specifications;

Hydraulic valve: **“Open Center”**
 Flow Requirement: **20, 30 or 40 l/min**
 (5, 8 or 10 gal/min)
 Maximum Pressure: **140 bar (2000 psi) or higher**

Examples of Husqvarna hydraulic tools that can be used with the PP 418 without any modifications:

Hand Saw	K2500
Ring Saws	K3500, K3600
Core Drill	DM406H
Wall Saw	WS325

Other popular tools are:
 Hydraulic Chain Saw
 Hydraulic Water Pump
 Hydraulic Breaker

If you are unsure of the compatibility of any tool - please consult the tool manufacturer or Husqvarna Construction Products.



CAUTION

If a tool requires 20 lpm/5 gpm of flow - it **SHALL NOT** be operated with a higher setting – such as 8 or 10 gal/min. This can cause severe damage to the tool or even personal injury.

Always consult the manufacturer of a tool before hooking it up to the power pack.

HYDRAULIC HOSES AND COUPLERS

The PP 418 includes a 7.5 m (25 ft) long hose set in a 1/2” (12.7 mm) inside diameter. You can attach ONE additional 1/2” hose of up to 10 m (33 ft) (total of 18-20 meters / 60-65 ft). If you require a longer hose for your application we recommend the following:

Maximum hose extension - up to 40 m (130 feet) total distance:
 - Use the 7.5 m (25 feet) of hose included with the power pack.
 - Make two 16 m (53 ft) extension hoses in a minimum of 5/8” (16 mm) hose diameter.

One 32 m (100 ft) length can also be used - however it is more bulky to handle.

We strongly recommend using HTMA “Flat Face” compatible quick couplers.

NOTICE:

The direction of flow through the system is always; male fitting into the female fitting. This means that any extension hoses should be made up the same way. If you have a male fitting in one end of a hose you should always have a female fitting in the opposite end. Never use two fittings of the same gender on the same hose.



CAUTION

The hydraulic oil and therefore the hoses and hydraulic couplers can get scalding hot during normal operation.

A hydraulic coupler at a temperature of 50°C (120°F) will be perceived as HOT to the touch. It is normal that the power pack oil might become as hot as 60°C (145°F) if operated on a very hot day with ambient temperatures exceeding 40°C (104°F).

For reference - a car engine typically operates at 90°C (195°F)



CAUTION

The hydraulic hoses and fittings shall have a minimum pressure rating of 140 bar (2000 psi) with a safety factor of 4 to 1.

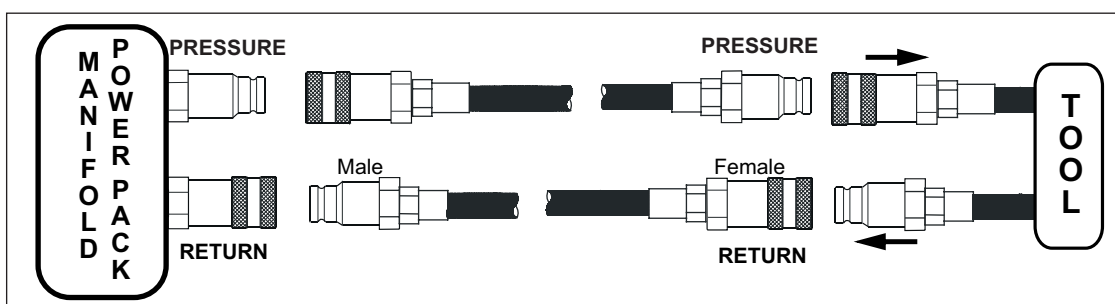

FUEL HANDLING



WARNING

Taking the following precautions will lessen the risk of injury and property damage:

- Use extreme care in handling gasoline. It is extremely flammable and the vapors are explosive.
- Extinguish all cigarettes, cigars, pipes, and other sources of ignition.
- Use only approved gasoline containers.
- Never remove gas cap or add fuel with the engine running. Allow engine to cool a minimum of 3 minutes before refueling.
- Never fuel the machine indoors.
- Never store the machine or fuel container where there is an open flame, spark, or pilot light such as on a water heater or other appliances.
- Never fill containers inside a vehicle or on a truck or trailer bed with a plastic liner. Always place containers on the ground away from your vehicle when filling.
- Remove the power pack from the truck or trailer and refuel it on the ground. If this is not possible, then refuel the equipment with a portable container, rather than from a gasoline dispenser nozzle.
- Keep the nozzle in contact with the rim of the fuel tank or container opening at all times until fueling is complete. Do not use a nozzle lock-open device.
- If fuel is spilled on clothing, change clothing immediately.
- Never overfill fuel tank. Always wipe off any spilled fuel or oil. Replace fuel cap and tighten

PROPER FUEL

The BRIGGS & STRATTON engine is certified to operate on unleaded gasoline with a pump octane rating (M+R) of **86** or higher, or a research octane rating (R) of **91** or higher.

Refuel in a well-ventilated area with the engine **stopped**.

You may use regular unleaded gasoline containing no more than 10% ethanol (E10). Do not use gasoline containing methanol.

Use of fuels with an ethanol content of more than 10% (E10) may cause starting and/or performance problems. It may also damage metal, rubber, and plastic parts of the fuel system, as well as posing a fire hazard.

Do not use fuel that is older than 30 days. Old fuel can cause running problems as well as fuel system damage.

The engine will not operate on gasoline marketed as E-85 (85% ethanol)

OIL HANDLING

NOTICE

Used oil is a hazardous waste product. Dispose of used oil properly. Do not discard with household waste. Check with your local authorities, service center, or dealer for safe disposal/recycling facility.

ENGINE OIL

Oil Recommendation

The engine holds approximately 1.4 liters (1-1/2 qts - 48 ounces) when changing oil and oil filter.

- Use a high quality detergent oil classified "For Service SF, SG, SH, SJ" or higher.
- BRIGGS & STRATTON strongly recommends the use of Synthetic oil.
- Do not use special additives.
- Choose a viscosity according to the table below.

Use of synthetic oil does not alter required oil change intervals.

Please read the enclosed BRIGGS & STRATTON Operator's Manual for complete oil information.

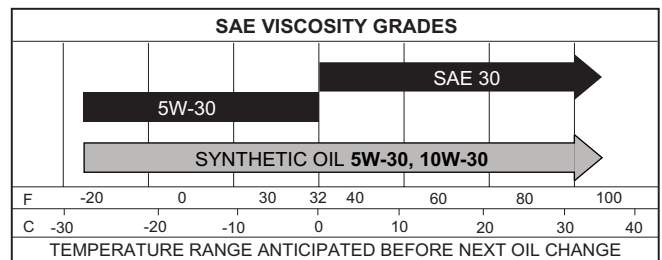

HYDRAULIC OIL

Any high quality hydraulic oil with a viscosity rating of **ISO 46 (46 cSt)** can be used.

High quality hydraulic oils that are marketed as "**Biodegradable**" can be used with a viscosity rating equivalent of ISO 46.

NOTE:

Biodegradable hydraulic fluids may require different service intervals compared to the traditional mineral based oils. Consult and follow the oil manufacturers recommendations regarding the service life of the oil.

The Hydraulic system is also compatible with some "Food Grade" oils that can be used for specific applications. Please contact Husqvarna Construction Products for advice.

ASSEMBLY

NOTICE

The PP 418 power pack must be serviced before use. In some markets the power pack will be delivered filled with both engine oil and hydraulic oil.

Remove the power pack from its shipping material and place it on a level surface.



CAUTION

Only use the lifting eyelet when lifting the power pack.

Step 1

Check the engine oil level. If no oil is present on the dipstick add oil in accordance to the recommendations on page 8 or consult the BRIGGS & STRATTON Operator's Manual.

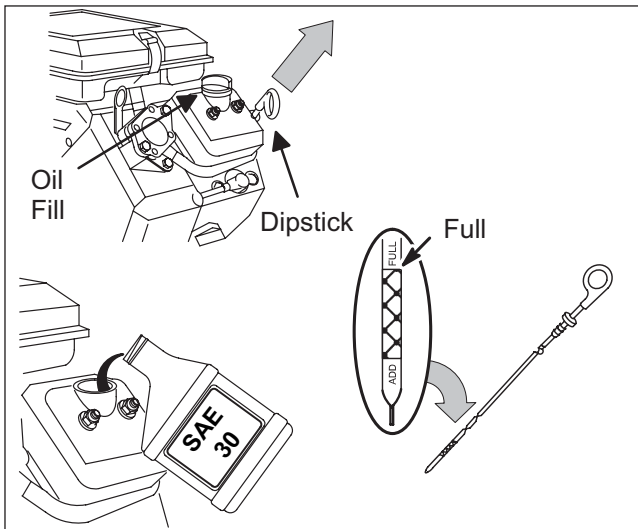

Step 2

Fill the hydraulic oil tank. Use only a high quality hydraulic oil – ISO 46. See page 8 for other alternatives. The total first time oil amount needed is 10 liters (2.6 gal) to fill the tank. The oil should be filled to the middle of the sight glass.

The oil level must be rechecked and refilled after the initial test running has been done - see page 12.

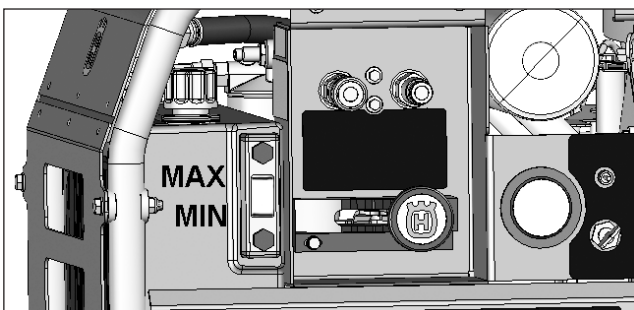

Step 3

Hook up the hydraulic hoses to the power pack. Connect the two couplers in the free end of the hose. The hoses are now ready to be charged with oil from the oil tank.

NOTE:

The hoses can be installed with either end to the power pack. Any set of hoses assembled with the couplers as in this illustration will always have full compatibility between power pack, hoses and tool.

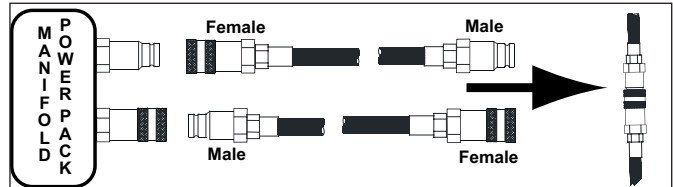

If the hydraulic hoses (7.5 m/25 ft) are empty they will require approximately 1.8 liters (2 quarts) of additional oil to be added to the oil tank after running the power pack for the first time.

If an additional 30 m (100 ft) of 5/8" hose set is used they will require approximately 12 liters (3.2 gal) to be added. The oil level in the oil tank must be rechecked several times when filling a new hose set.

Step 4

Check the tire pressure. The wheels are tubeless. If the tire pressure becomes too low the wheel will deflate completely. Inflate to 2 bar (30 psi)

Step 5

The power pack is delivered without the battery cables installed to the battery. Please read; **SERVICING THE BATTERY** on page 10.

The original equipment battery is maintenance free. Do not attempt to open or remove caps or covers. Adding or checking the level of electrolyte is not necessary.



WARNING

Lead-acid batteries generate explosive gases. Keep sparks, flame and smoking materials away from batteries. Always wear eye protection when around batteries.

Step 6

Fill the fuel tank with fresh clean gasoline. See warnings and recommendations on page 8. Add only fuel in a quantity that will be used within 30 days to assure fuel freshness. If the power pack is stored with fuel in the tank for longer periods we recommend to use a commercially available "Fuel Stabilizer".

SERVICING THE BATTERY

Use the following procedure when removing, installing and attaching the battery cables.

The battery is located in the support foot of the power pack. To access the battery you will need another person helping you.

Step 1

Remove the two M8 bolts using a 10 mm wrench. Keep the two bolts nearby for Step 3

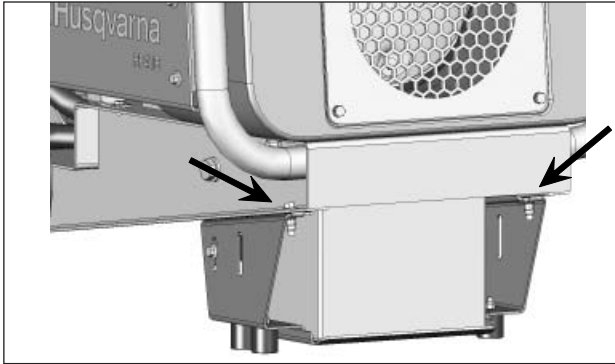

Step 2

Have one person lift the power pack with the handle. With the "battery box" no longer supporting the power pack it can be pivoted downward. This will give you full access to the battery and cables.

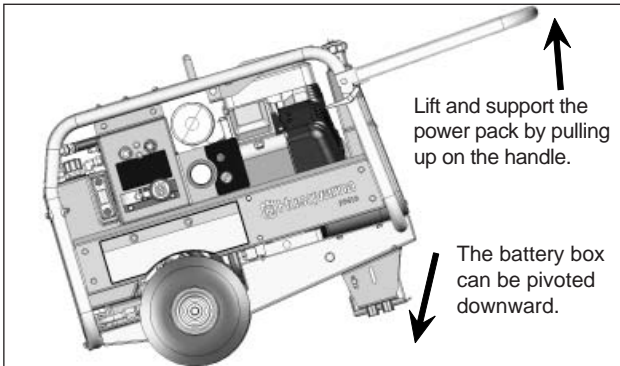

Step 3

Secure the battery box in the "open" position by inserting the two M8 screws removed in Step 1 into the exposed holes in the battery box (see illustration). Use one bolt on each side.

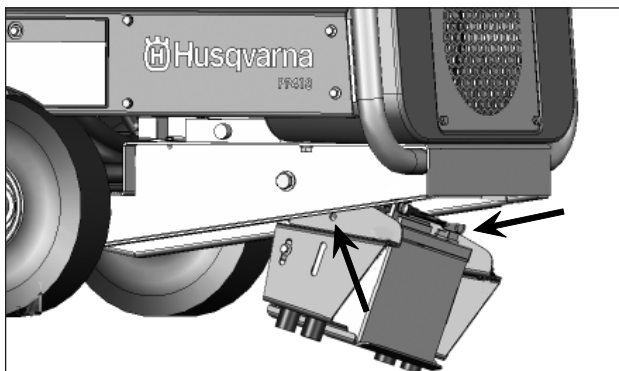

The battery supplied as original equipment is maintenance free. Do not attempt to open or remove caps or covers. Adding or checking the electrolyte level is not necessary. Replace only with an equivalent maintenance free battery with the following specifications;

Case size: **U1**
Min. CCA: **230**

WARNING

- Connecting and disconnecting a battery can cause sparks and short circuits. Do not short battery terminals by allowing a wrench or any other object to contact both terminals at the same time.
- A spark or flame can cause a lead acid battery to explode.
- Before connecting a battery, remove metal bracelets, wristwatch bands, rings, etc. Use gloves and protective glasses or face shield when working with a battery.
- Install and remove the battery cables **ONLY** in the sequence described in this section.



Eye Protection



Protective Gloves



Explosion Danger

CONNECTING A BATTERY

First - always install the RED (+) cable to the positive (+) terminal on the battery. Secure the cable to the terminal with the 5/16" screw and nut. (13 mm or 1/2" wrench).

Second - install the BLACK (-) ground cable to the negative (-) terminal on the battery. Secure the cable to the terminal with the 5/16" screw and nut.

DISCONNECTING A BATTERY

First - always disconnect the BLACK (-) ground cable from the battery. (13 mm or 1/2" wrench).

Second - disconnect the RED (+) cable.

CHARGING A BATTERY

The only safe way to charge a battery is to completely remove the battery from the power pack. A standard battery charger can be used with a charging power of 12 volt and 2 to 10 amp. Follow all instructions for your battery charger before hooking it up to the battery.

JUMPER CABLES

DO NOT use jumper cables between the power pack and a secondary battery source such as a car.

If the battery is weak and can not start the engine either remove and recharge or replace the battery. Do not attempt to use jumper cables. There is no safe way to attach jumper cables.

CONTROLS - OPERATION

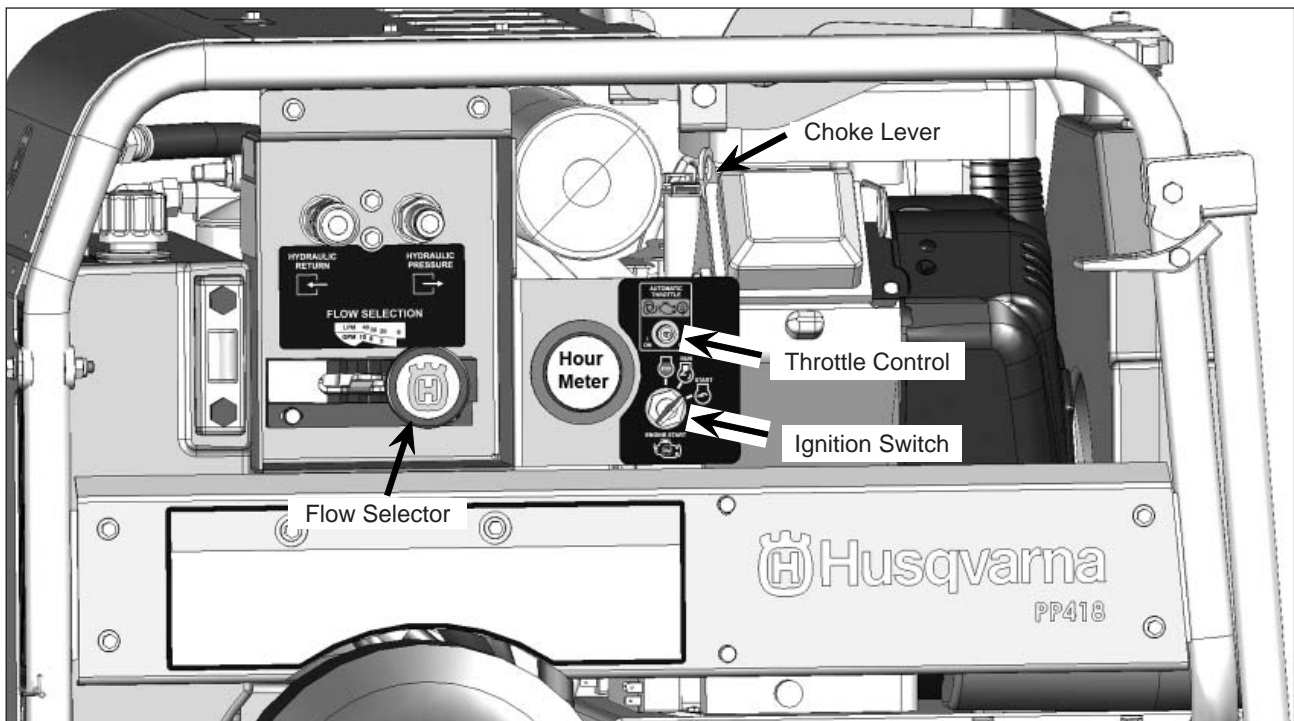

IGNITION SWITCH

STOP – Kills the engine – no power to any of the electrical devices.

RUN – Run position for the engine. Please note that the hour meter will collect time whether or not the engine is running. If the key is left in the RUN position the battery will also loose power more quickly.

START – Turns the engine starter motor.

THROTTLE CONTROL

The engine has a very accurate electronic throttle and governing system. The engine speed is strictly controlled electronically and you cannot make any simple mechanical adjustments to the governing system. The electronic control will accurately hold the speeds as indicated below.

The throttle control switch allows you to select one of two different operating throttle control modes:

1. Automatic throttle control switch in the **OFF** position.
 - During the starting procedure the engine will run at 2100 RPM for 5 seconds.
 - After 5 seconds the engine speed will increase to 3100 RPM and hold that speed.
2. Automatic throttle control switch in the **ON** position.
 - During the starting procedure the engine will run at 2100 RPM for 5 seconds.
 - After 5 seconds the idle speed will drop to 1900 RPM.
 - When the trigger on a tool is activated a pressure sensor switch on the power pack will increase the engine speed to 3100 RPM.
 - When the tool is no longer used the engine speed will drop back to 1900 RPM after 5 seconds.

cont..

There is a slight delay for the engine to go from idle speed to full throttle operation. To help prevent this inconvenience, the full throttle position is maintained for 5 seconds. This is particularly helpful when a tool is operated intermittently (Hydraulic Breaker for example) and full power is required instantly.

If desired, full throttle operation can be maintained by moving the Automatic throttle control switch to the **OFF** position.

The sensitivity of the automatic throttle control system can be adjusted to compensate for conditions such as increased back pressure from adding hose extensions, operation at lower temperatures, oil viscosity differences, etc.

Please see “**ADJUSTING THE AUTOMATIC THROTTLE**” on page 13.

FLOW SELECTOR

To adjust the oil flow **PULL** out on the flow selector knob and move it to the left for the desired oil flow. Please consult the operator’s manual for flow requirements of a specific tool. Do not use a higher than recommend setting since that can damage the tool.

After the work is finished **ALWAYS** return the flow selector to “**0**” before stopping the engine.

Always start the engine with the flow selector in the “0” position. This ensures that the electric starter can turn over the engine.

This power pack is capable of producing up to 40 liter/ 10 gal of oil flow per min. The factory pressure relief valve setting is 148bar (2150psi) “cracking” pressure.

STARTING CHECKLIST

BEFORE YOU OPERATE THE POWER PACK, PLEASE REVIEW THE FOLLOWING CHECKLIST:

- Have you read and do you understand ALL instructions and warnings in this manual?
- Is the battery properly charged and installed? (page 10)
- Are the tires properly inflated? (page 9)
- Is the engine oil at the proper level? (page 9)
- Is the fuel tank filled with fresh, clean, regular unleaded gasoline? (page 8)
- Has the hydraulic tank been filled to the proper level? (pages 8 and 9)
- Are you familiar with the controls, their location and function? Operate them before you start the engine.
- Have you attached the hydraulic hoses to the power pack? Connect the other end of the hoses to a hydraulic tool or to each other. (page 9)



WARNING

Before each use, carefully inspect the power pack for any damage to any of its parts and components. Pay careful attention to any leakage of gasoline or oil. Under no circumstance should the power pack or any of its attachments be operated if you find damage or are suspicious that something appears to be damaged.

STARTING PROCEDURE:



WARNING

ASPHYXIATION HAZARD

Running an engine in a confined or badly ventilated area can result in injury or death due to asphyxiation or carbon monoxide poisoning.

NOTICE:

STARTING THE FIRST TIME

If the power pack was received without hydraulic oil in the tank and hoses, the oil levels must be checked carefully before using it for the first time.

A new empty hydraulic hose set will require approx. 1.8 liters (2 quarts) of oil.

After starting the power pack and turning the flow selector to the desired setting, the oil will fill the hydraulic hoses. Before putting the machine to work the hydraulic oil tank level should be checked.

Stop the engine and add hydraulic oil as needed.

Before starting;

Always set the flow controller to "0" before starting. Connect the hoses to the tool and to the power pack. The AUTOMATIC THROTTLE switch can be turned to either ON or OFF.

After starting;

Let the engine warm up for 1 to 2 minutes. Turn the FLOW SELECTOR to the desired setting. This makes the hydraulic oil flow from the pump through the hoses to the tool.

In cold weather we recommend letting the power pack pump the oil through the hoses and the tool until the temperature of the oil has reached a minimum of 10°C (50°F) before using the tool. This ensures the proper function of the automatic throttle.

See page 13 for a full explanation on how to adjust the sensitivity of the AUTOMATIC THROTTLE function.

ADJUSTING THE AUTOMATIC THROTTLE

GENERAL DESCRIPTION

The AUTOMATIC THROTTLE function is triggered by an adjustable pressure switch located on the hydraulic manifold.

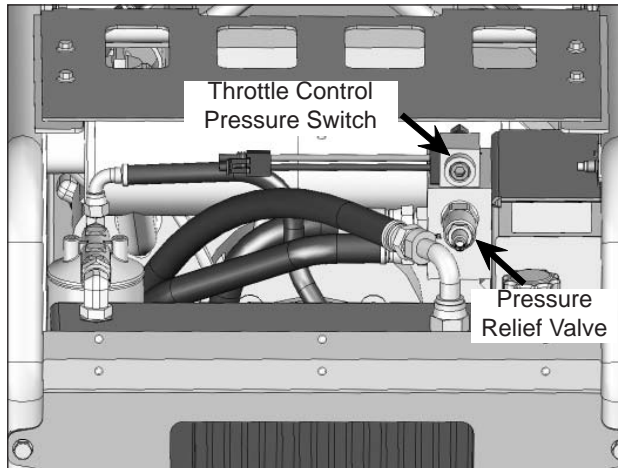

When the flow selector is set to (for example) 40 liters (10 gal), that amount of oil will circulate through the hoses and through the tool and back to the tank.

The circulation of the oil through the hoses creates a small pressure (known as “back pressure”) at the pressure switch.

The back pressure in the system can vary for many reasons such as;

- Cold hydraulic oil
- The length of the hoses – a longer hose creates more back pressure.
- The valve in the hydraulic tool can have a high restriction.

In some applications the hydraulic system restriction may be too low. This will cause the engine to remain at idle speed even after the tool is engaged and full power is required.

When a trigger is activated at the tool, the oil pressure quickly rises to in excess 50 bar (700 psi). This normally triggers the AUTOMATIC THROTTLE control to increase the throttle to “FULL”. It is desirable that the engine engages to full throttle immediately when the tool is activated.

ADJUSTMENT

On the PP 418 the threshold pressure at which the throttle reacts can be adjusted to reach a desired function for a specific tool and condition.

Step 1

Hook up the hoses and tool to be used.

Step 2

Turn the AUTOMATIC THROTTLE switch to the **ON** position. Start the engine and let it idle for 1 minute. The engine will now idle at 1900 RPM.

Step 3

Turn the FLOW SELECTOR to the proper setting for the tool. **Note:** If the oil is cold the back pressure in the system can trigger the full throttle function.

Step 4

Let the hydraulic oil warm up for one or two minutes. It is now OK to start the work. The hydraulic oil will reach a stabilized operational temperature in approximately 5 to 10 minutes.

Step 5

If the machine has been operated for 10 minutes and the AUTOMATIC THROTTLE function is not working correctly the pressure threshold value between the idle and full throttle function can be adjusted.

NOTICE:

The Throttle Control Pressure Switch setting has NO impact on the relief valve setting (= maximum system pressure). It is strictly sensing the system pressure to signal the controller to operate the engine at Idle or Full Throttle. **DO NOT** adjust the pressure relief valve.

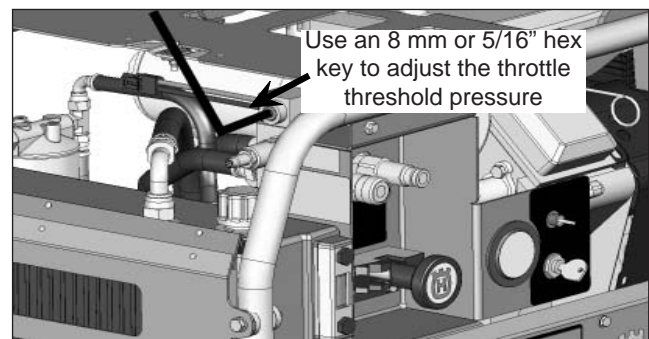

Scenario 1.

With the Automatic throttle switch in the **ON** position, the engine will stay at FULL THROTTLE even when the hydraulic oil is hot.

Adjustment

Turn the Adjustment Screw - **Clockwise** in 1/8 turn increments until proper function is achieved.

Scenario 2.

The engine will remain at IDLE SPEED when the tool is engaged. It might work OK when the oil is cold.

Adjustment

Turn the Adjustment Screw - **Counter Clockwise** in 1/8 turn increments until proper function is achieved.

ENGINE MAINTENANCE

Engine Oil

Checking, Adding and Changing Oil

Always check the oil level before starting the engine. Keep oil level at FULL. Do not overfill. Check level daily, or after every eight (8) hours of use.

Note: Engine holds approximately 1.4 liters (1.5 quart) when changing oil and oil filter.

Always place the Power Pack on a level surface when checking and changing the oil

Changing the Oil and Filter

Change oil after the first 5 to 8 hours of use. Thereafter every 50 hours .

Follow the recommendations on page 8 as well as in the BRIGGS & STRATTON Operator's Manual.

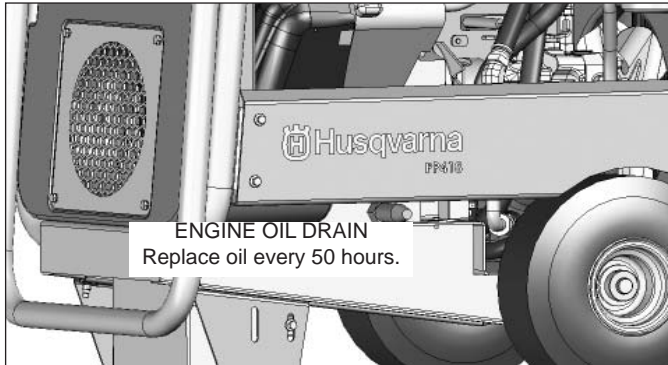

Change Oil Filter after every 100 hours

We strongly recommend to only use the BRIGGS & STRATTON original replacement parts

OIL FILTER ACCESS

Remove the 6 screws as indicated below. This will enable full access to the engine oil filter.

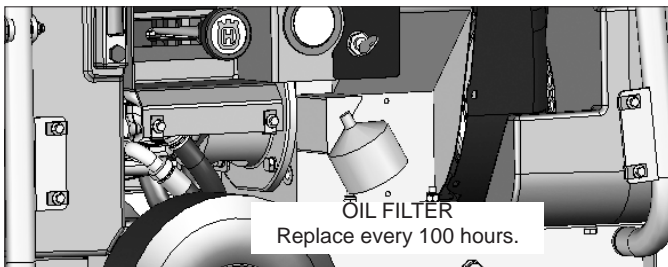
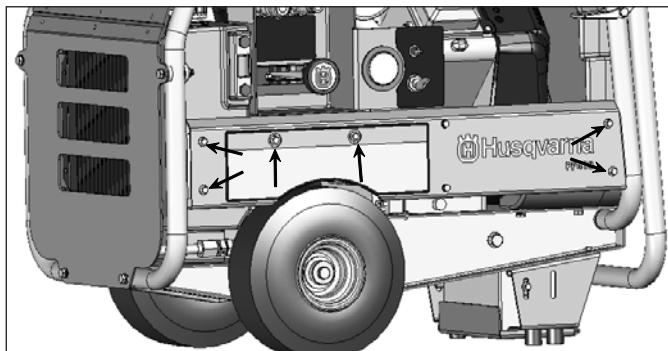

NOTICE

Used oil is a hazardous waste product. Dispose of used oil properly. Do not discard with household waste. Check with your local authorities, service center, or dealer for safe disposal/recycling facility.

1. With engine OFF but still warm, remove oil drain plug and drain oil into appropriate receptacle and remove the oil filter.
2. Before installing new filter, lightly oil filter gasket with fresh, clean oil.
3. Screw filter on by hand until gasket contacts oil filter adapter. Tighten 1/2 to 3/4 turn more.
4. First add 1 liter (1 quart) of any of the specified oil qualities.
5. Start and run engine for 30 seconds.
6. Stop engine. Re-check oil level – Top off as necessary – typically 0.3 - 0.5 liter (12 - 16 oz).

Oil Pressure

- If the oil pressure drops below 0.1-0.2 kg/cm (1-4 psi), an oil pressure switch will stop the engine.

- If oil level is below the ADD mark on dipstick, add oil to bring level to FULL mark. Try to start the engine.

- If this does not correct the problem contact an authorized BRIGGS & STRATTON service dealer.

AIR FILTER

Your engine will not run properly using a dirty air filter. Inspect and service the air cleaner at each oil change - every 50 hours.

MUFFLER

Inspect and replace corroded muffler and spark arrester (if equipped) as it could create a fire hazard and/or damage. Also - inspect the spark arrester screen for carbon deposits. A partially plugged screen will cause loss of power. It is recommended to inspect the screen at each oil change.

IN-LINE FUEL FILTER

The fuel filter should be replaced once each season. If fuel filter becomes clogged, obstructing fuel flow to carburetor, replacement is required. We recommend to replace the fuel filter every 250 hours

ADDITIONAL ENGINE INFORMATION

Please see the BRIGGS & STRATTON Operator's Manual for additional information about servicing the engine.

The manual also has specific information about specifications, tune-up parts, engine warranty, emission compliance, etc.

HYDRAULIC MAINTENANCE

HYDRAULIC SYSTEM SPECIFICATIONS

Oil Tank volume: 10 liter (2.6 gal)

Oil Type: ISO 46 (see page 8)

Hydraulic Filter (large):

510 02 33-01 25 Micron filter

Hydraulic Filter (small):

542 16 64-49 25 Micron filter

NOTICE: *Never use automotive type oil filters.*

They do not have the required flow capacity and can burst during operation.

Replacement Frequency:

Both Filters - After 1st 50 hours,
then every 100 hours

Hydraulic Oil - Every 100 hours
or once a year

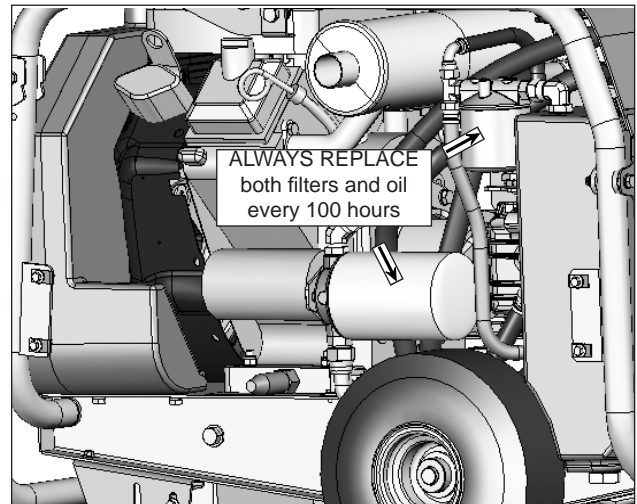

SYSTEM MAINTENANCE

Daily

1. Check hydraulic oil level. Make sure that the oil level on the sight glass is above the lower limit indicated. Add oil as needed.

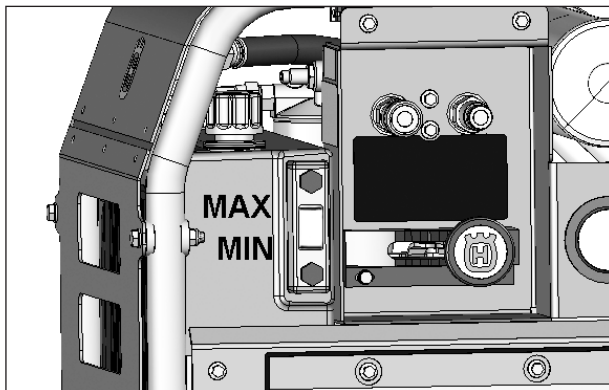

2. Check for any leaks or kinks on the hydraulic hoses or any other leaks at couplers and fittings.

3. Check oil cooler for any debris and dirt buildup. Remove debris with air pressure or spraying with a garden hose. Do not use a high pressure washer directly on the cooler.

REPLACING OIL AND FILTER

Remove the 4 screws as indicated below. This will enable full access to the large oil filter.

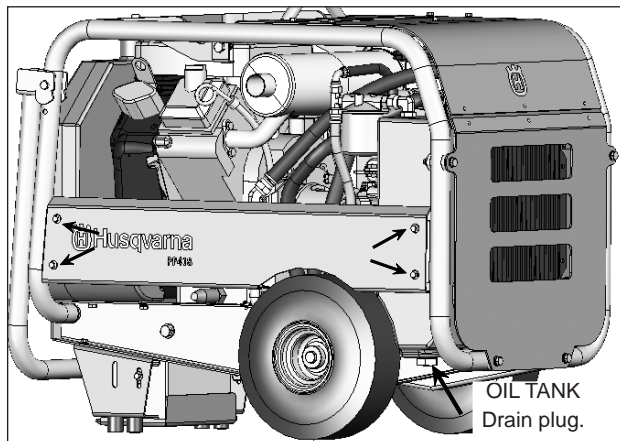

WATER CONTAMINATION

In humid climates the hydraulic system can collect large amounts of water condensation in the oil tank. This happens due to the humid air in the tank changing from getting hot and cold. Small amounts of water condensation will not be noticeable. If large amounts of water are present, the oil will "foam" or turn "white". The power pack and other hydraulic tools should not be operated with water contaminated oil.

If water contamination occurs you should replace the oil and filters. In some cases it is feasible to remove the water contamination out of the oil. The hydraulic hoses should also be emptied.

Procedure for removing the water:

1. Install the hoses and connect the ends together.
2. Start the engine and turn on the flow selector to the 40 liters (10 gal)
3. Let the engine operate for 5 minutes at this flow setting.
4. Turn off the engine and drain the oil tank in an appropriate container. Preferably – remove the quick couplers on the hoses and drain oil into a container.
5. The water in the contaminated oil will settle at the bottom of the container in approximately 24 hours. The oil will now appear "normal".
6. Carefully pour the clean oil back into the tank – leaving the water in the container.
7. REPLACE the oil filters.

TROUBLESHOOTING THE HYDRAULIC SYSTEM

To adequately diagnose and troubleshoot any problems related to the hydraulic system it is necessary to have a hydraulic tester consisting of a flow meter and pressure gauge. Never readjust the pressure relief valve without the proper hydraulic diagnostic tool.

CONTACT a local Husqvarna dealer or Husqvarna Construction Products for diagnostic help.

TECHNICAL SPECIFICATIONS

Weight and Dimensions PP 418

Weight – dry without hoses	127 kg	280 lbs
Weight with oil but without gasoline	135 kg	298 lbs
Weight - hose set ½" x 7.5 m (25 feet) – dry	8.5 kg	19 lbs
Weight - hose set – with oil	10 kg	22 lbs
Length (handle folded in)	895 mm	35 inch
Length (handle folded out)	1300 mm	51 inch
Width	530 mm	21 inch
Height	740 mm	29 inch
Height (with the hose/tool rack folded out)	895 mm	35 inch

Engine:

Engine oil volume	1.4 liters	1.5 quarts
Gasoline tank volume	11.4 liters	3 gal

Hydraulics:

Hydraulic system - Tool	Open center valve
Hydraulic system - Power Pack	Closed loop
Pump type	Variable displacement piston pump
Flow output	20, 30, 40 liters/min 5, 8, 10 gpm
Pressure relief valve setting ("cracking")	148 bar 2150 psi
Main filter (large)	25 micron,
Pump filter (small)	25 micron
Oil tank volume	10 liters 2.6 gal
Oil type	ISO 46
Oil cooling	Air cooled, forced air. Meets HTMA cooling requirement.

Electrical System:

Battery type	U1 size, 12V – 230 CCA
Fuse	10 Amp – Automotive type (Located by electric starter)

WARRANTY

HUSQVARNA EQUIPMENT WARRANTY

New Hydraulic Power Packs sold by Husqvarna Construction Products are warranted to be free from manufacturing defects in normal service for a period of one (1) year from date of purchase by the original consumer purchaser. Please see the enclosed warranty registration card for the complete warranty statement.

The BRIGGS & STRATTON engine warranty is two (2) years from the date of purchase by the original consumer purchaser. Please see the complete warranty statement included in the engine Operator's Manual.

Our obligation under this warranty is expressly limited to the replacement or repair at Husqvarna Construction Products, or at a service facility designated by us, of such part or parts if inspection shall disclose it to have been defective.

This warranty does not apply to defects caused by damage, unreasonable use, faulty repairs made by others (or defects caused by failure to provide reasonable maintenance, while in the possession of the consumer). Further, the warranty is void if the product, or any of its components, are altered or modified by the consumer purchaser, or if the product is used in an inappropriate manner not recommended by the manufacturer.

CONFORMITY CERTIFICATES

CALIFORNIA AIR RESOURCES BOARD (CARB): This machine is considered a preempt Off-Road Application as relating to CARB standards. Under construction equipment, and in particular, as a Hydraulic Power Pack (Power pack: hydraulic), with engine power less than 19KW (25hp), CARB standards do not apply to this machine.

For more information see the website <http://www.arb.ca.gov/msprog/offroad/preempt.htm>



www.husqvarnacp.com

510 02 98-01