



Hydro-Smart 115

“Micro Boiler” for Radiant Heating Installation Manual and Owner’s Guide



ANSI Z21.10.3 and CSA 4.3

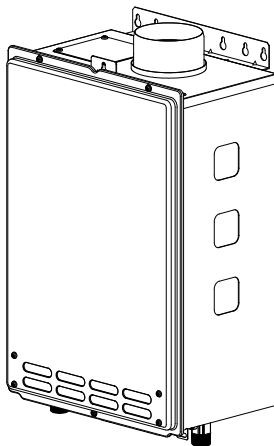

Hydro-Smart 115



WARNING

If the information in these instructions is not followed exactly, a fire or explosion may result causing property damage, personal injury or death.

-Do not store or use gasoline or other flammable vapors and liquids in the vicinity of this or any other appliance.

-WHAT TO DO IF YOU SMELL GAS

- Do not try to light any appliance.
- Do not touch any electric switch, do not use any phone in your building.
- Immediately call your gas supplier from a neighbor's phone. Follow the gas supplier's instructions.
- If you cannot reach your gas supplier, call the fire department.

-Installation and service must be performed by a qualified installer, service agency or the gas supplier.

If you have any questions, please call or write to:

Hydro-Smart Inc.

10725 165th Ave NW,

Elk River, MN 55330

Please make sure the proper gas pressure guidelines and recommendation from Hydro-Smart failure to do so can cause a fire or explosion and may result, causing property damage, personal injury, or death.

CONTENTS

Installation Manual

SPECIFICATIONS.....	3
INTRODUCTION.....	4
SAFETY GUIDELINES.....	5
INSTALLATION.....	6
General.....	6
Clearances.....	8
Included Accessories.....	8
Optional Items.....	9
Warning for Installations.....	10
High-Altitude Installations.....	11
Venting Instructions.....	12
Gas Supply and Gas Pipe Sizing.....	17
Water Connections.....	20
Electrical Connections.....	21
Remote Controller Connections.....	22
APPLICATIONS.....	23
INITIAL OPERATION.....	25

Owner's Guide

OPERATING SAFETY.....	26
NORMAL OPERATION.....	28
General.....	28
Operation.....	28
Temperature Settings.....	29
Flow.....	30
Freeze Protection System.....	30
Maintenance and Service.....	31
Unit Draining.....	31
TROUBLESHOOTING.....	32
General.....	32
Error Codes.....	34
COMPONENTS DIAGRAM.....	37
PARTS LIST.....	39
OUTPUT TEMPERATURE CHART.....	41
LIMITED WARRANTY.....	42

Installation Manual

SPECIFICATIONS

Model		Hydro-Smart 115	
Natural Gas Input (Operating Range)		Min: 19,500 Btu/h Max: 140,000 Btu/h	
Propane Input (Operating Range)		Min: 19,500 Btu/h Max: 140,000 Btu/h	
Gas Connection		¾" NPT	
Water Connections		¾" NPT	
Water Pressure		15 - 150 psi*	
Natural Gas Inlet Pressure		Min. 5.0" WC Max. 10.5" WC	
Propane Inlet Pressure		Min. 8.0" WC Max. 14.0" WC	
Manifold Pressure**	Natural	2.0" WC	
	Propane	2.5" WC	
Weight		33 lbs.	
Dimensions		H20.5" x W13.8" x D6.7"	
Ignition		Electric Ignition	
Electric	Supply	120 VAC / 60 Hz	
	Consumption	Operation	73.1 W / 0.61 A
		Standby	6.2 W / 0.05 A
		Freeze- Protection	111 W / 0.93 A

*40 psi or above is recommended for maximum flow.

The Manifold Pressure is the factory setting and generally **should not need adjustment.

NOTE:

- Check the rating plate to ensure this product matches your specifications.
- In accordance with ANSI Z21.10.3, CO emission does not exceed 400 PPM for normal input.
- **Hydro-Smart reserves the right to discontinue, or change at any time, specifications or designs without notice and without incurring obligations.**

INTRODUCTION

- This manual provides information necessary for the installation, operation, and maintenance of the water heater.
- The model description is listed on the rating plate which is attached to the front panel of the water heater.
- Please read all installation instructions completely before installing this product.
- If you have any problems or questions regarding this equipment, consult with Hydro-Smart.
- Hydro-Smart 115 is a water heater designed to be used with radiant heating in a combination Hydro Panel.
- Please read all installation instructions completely before installing this product.
- **This product is only to be used with Hydro-Smart Heating Panels, "Integrator".**
- The principle behind tankless water heaters is simple:

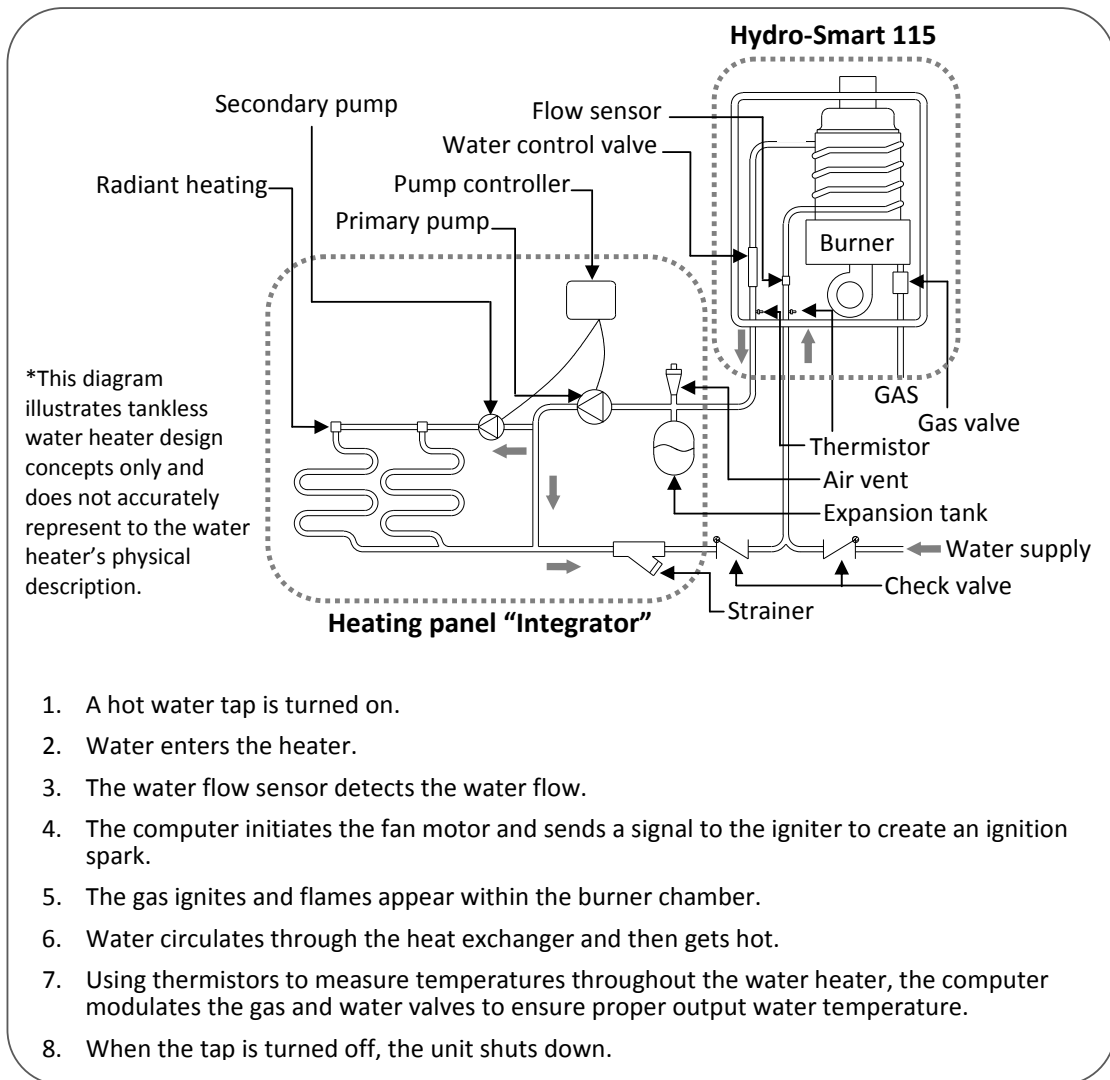

SAFETY GUIDELINES

SAFETY DEFINITIONS



Indicates an imminently hazardous situation which, if not avoided, will result in death or serious injury.



Indicates an imminently hazardous situation which, if not avoided, could result in death or serious injury.



Indicates an imminently hazardous situation which, if not avoided, could result in minor or moderate injury.

GENERAL

1. Follow all local codes, or in the absence of local codes, follow the most recent edition of the National Fuel Gas Code: ANSI Z223.1/NFPA 54 in the USA or CAN/CSA B149.1 Natural Gas, Propane Installation Code in Canada.
2. Properly ground the unit in accordance with all local codes or in the absence of local codes, with the National Electrical Codes: ANSI/NFPA 70 in the USA or CSA standard C22.1 Canada Electrical Code Part 1 in Canada.
3. Carefully plan where you intend to install the water heater. Please ensure:
 - Your water heater will have enough combustible air and proper ventilation.
 - Locate your heater where water leakage will not damage surrounding areas (please refer to p. 7).
4. Check the rating plate for the correct **GAS TYPE, GAS PRESSURE, WATER PRESSURE and ELECTRIC RATING**.
*If this unit does not match your requirements, **do not install and consult with Hydro-Smart**.
5. If any problem should occur, turn off all hot water taps and turn off the gas. Then call a trained technician or the Gas Company or Hydro-Smart.



- Water temperatures over 125°F (52°C) can cause severe burns instantly or death from scalding. The water temperature is set at 122°F (50°C) from the factory to minimize any scalding risk. Before bathing or showering always check the water temperature.
- Do not store or use gasoline or other flammables, vapors, or liquids in the vicinity of this appliance.
- Do not reverse the water and/or gas connections as this will damage the gas valves and can cause severe injury or death. Follow the diagram on p. 20 when installing your water heater.
- Do not use this appliance if any part has been in contact with or been immersed in water. Immediately call a licensed plumber, a licensed gas fitter, or a professional service technician to inspect and/or service the unit if necessary.
- Do not disconnect the electrical supply if the ambient temperature will drop below freezing. The Freeze Prevention System only works if the unit has electrical power. The warranty will not be covered if the heat exchanger is damaged due to freezing. Refer to the section on the Freeze Prevention System on p. 30 for more information.

INSTALLATION

GENERAL

1. Follow all local codes, or in the absence of local codes, follow the most recent edition of the National Fuel Gas Code: ANSI Z223.1/NFPA 54 in the USA or CAN/CSA B149.1 Natural Gas, Propane Installation Code in Canada.
2. All gas water heaters require careful and correct installation to ensure safe and efficient operation. This manual must be followed exactly. Read the “Safety Guidelines” section.
3. The manifold gas pressure is preset at the factory. It is computer controlled and should not need adjustment.
4. Maintain proper space for servicing. Install the unit so that it can be connected or removed easily. Refer to the Clearances Section on p. 8 for proper clearances.
5. The water heater must be installed in a location where the proper amount of combustible air will be available to it at all times without obstructions.
6. The electrical connection requires a means of disconnection, to terminate power to the water heater for servicing and safety purposes.
7. Do not install the unit where the exhaust vent is pointing into any opening in a building or where the noise may disturb your neighbors. Make sure the vent termination meets the required distance by local code from any doorway or opening to prevent exhaust from entering a building (refer to p. 15).
8. Particles from flour, aerosols, and other contaminants may clog the air vent or reduce the functions of the rotating fan and cause improper burning of the gas. Regularly ensure that the area around the unit is dust- or debris-free; regular maintenance is recommended for these types of environment.
9. If you will be installing the water heater in a contaminated area with a high level of dust, sand, flour, aerosols or other contaminants/chemicals, they can become airborne and enter and build up within the fan and burner causing damage to the water heater.
10. For the Hydro-Smart 115:
 - These units may be converted to a direct-vent (sealed combustion) appliance by installing a direct-vent conversion kit Part No. 9007667005 (TK-TV10) which will bring in all required combustible air from outside the building. When installing the direct-vent conversion kit, please follow all instructions included with the kit.
 - If the water heater is used as a direct-vent appliance, the unit requires a 3” combustible air supply pipe. The intake pipe must be sealed airtight. Air supply pipe can be made of ABS, PVC, galvanized steel, corrugated aluminum, corrugated stainless steel or Category III stainless steel.
 - Terminating the venting through a sidewall is recommended for the direct-vent system.
 - Running the exhaust vent and the intake pipe parallel is recommended.
 - Terminating the exhaust and intake on the same wall / surface is recommended. Terminating in the same pressure zone allows for pressure balancing, which prevents nuisance shutdowns.

**WARNING**

- **Installation and service must be performed by a qualified installer (for example, a licensed plumber or gas fitter), otherwise the warranty by Hydro-Smart will be void.**
- **The installer (licensed professional) is responsible for the correct installation of the water heater and for compliance with all national, state/provincial, and local codes.**
- **Hydro-Smart does not recommend installing the water heater** in a pit or location where gas and water can accumulate.
- Do not have the vent terminal pointing toward any operating window, door, or opening into a building.
- Do not install next to any source of airborne debris, such as a clothes dryer, that can cause debris to be trapped inside the combustion chamber, unless the system is direct-vented.
- **Hydro-Smart does not recommend installing the water heater in an attic due to safety issues.** If you install the water heater in an attic:
 - Make sure the unit will have enough combustion air and proper ventilation.
 - Keep the area around the water heater clean. When dust collects on the flame sensor, the water heater will shut down on an error code.
 - If the above conditions cannot be met, use the direct vent conversion kit Part No. 9007667005 (TK-TV10).
 - Place the unit for easy access for service and maintenance.
 - A drain pan, or other means of protection against water damage, is required to be installed under the water heater in case of leaks.

**CAUTION**

- **The warranty will not cover damage caused by water quality.**
 - Only potable water or potable water / glycol mixtures can be used with this water heater. Do not introduce pool or spa water, or any chemically treated water into the water heater.
 - Water hardness levels must not exceed 7 grains per gallon (120 ppm) for single family domestic applications or more than 4 grains per gallon (70 ppm) for all other types of applications. Water hardness leads to scale formation and may affect/damage the water heater. Hard water scaling must be avoided or controlled by proper water treatment.
 - Water pH levels must be between 6.5 and 8.5
 - Well water must be treated.
- Do not install the unit where water, debris, or flammable vapors may get into the flue terminal.
- **Hydro-Smart recommends using the direct vent kit when the water heater is installed in a beauty salon.** Some chemicals used in a beauty salon may affect the flame sensor. Water heater may not work properly.
- Although the water heater is designed to operate with minimal sound, **Hydro-Smart does not recommend installing the unit on a wall adjacent to a bedroom, or a room that is intended for quiet study or meditation, etc.**
- Locate your heater close to a drain where water leakage will not do damage to surrounding areas. As with any water heating appliance, the potential for leakage at some time in the life of the product does exist. Hydro-Smart will not be responsible for any water damage that may occur. If you install a drain pan under the unit, ensure that it will not restrict the combustion air flow.

CLEARANCES



Maintain all clearances around the water heater.

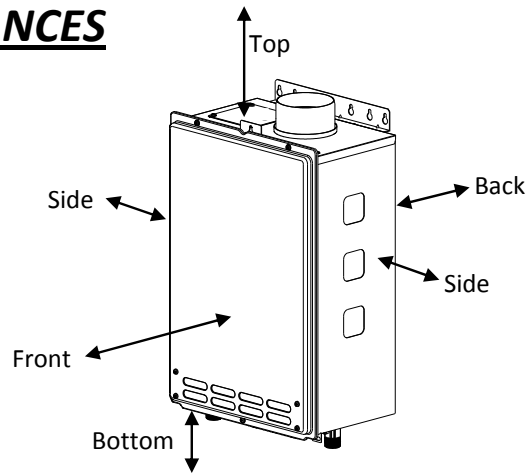



Model	Top	Bottom	Front	Back	Sides
Hydro-Smart 115*	12"	12"	24"	1"	2"

*Standard indoor installations and direct-vent indoor installations have the same clearances.

INCLUDED ACCESSORIES

Check that these items below are included with the water heater.

<p>1. Installation Manual and Owner's Guide</p>  <p>Qty: 1</p>	<p>2. Product Registration Card</p>  <p>Qty: 1</p>	<p>3. Remote controller 900766605 (TK-RE02)</p>  <p>Qty: 1</p>
----------------------------------------------------------------------------------------------------------------------------------------------------------	----------------------------------------------------------------------------------------------------------------------------------------------	------------------------------------------------------------------------------------------------------------------------------------------------------------

OPTIONAL ITEMS

Model	Hydro-Smart 115
9007678005 (TK-BF01)	✓
9007667005 (TK-TV10)	✓
9007671005 (TK-PCJr2)	✓
9007608005 (TK-KPWL4)	✓
9007609005 (TK-KPWH4)	✓
9007680005 (TK-KPCT43)	✓

1. Backflow Preventer: 9007678005 (TK-BF01)



The Backflow preventer prevents the backflow of air through the exhaust vent. This helps prevent harmful exhaust gases from entering the home, as well as helping to prevent the unit from freezing in areas where cold air can be blown or drawn into the exhaust system. Install this vent damper in accordance with the installation instructions and any applicable codes.

2. Direct-Vent Conversion Kit: 9007667005 (TK-TV10)



This kit can be used to convert the water heater from a standard vent system to a direct-vent (or sealed combustion) system.

Install this conversion kit in accordance with the installation instructions and any applicable codes.

3. Pipe Covers: 9007671005 (TK-PCjr2)



The pipe cover protects the plumbing pipes to the water heater from unexpected adjustments. This pipe cover is fixed to the bottom of the water heater, which hides the plumbing and improves the visual aspects of the whole installation for the water heater.

4. T-Vent Wall Thimble with Termination: 9007608005 (TK-KPWL4) and 9007609005 (TK-KPWH4)



Louver Termination
9007608005
(TK-KPWL4)



Hood Termination
9007609005
(TK-KPWH4)

These terminations are used when venting out through the wall and are compatible with the T-Vent pipe system.

These terminations are special stainless steel vents for gas appliances and are UL listed as Category II, III and IV. There are two types of terminations: the Louver termination and the Hood termination. For different wall thicknesses, there are two ranges of lengths available (refer to the venting brochure for details).

Install these vent terminations in accordance with their installation instructions and any applicable local codes.

5. Direct-Vent Concentric Termination: 9007680005 (TK-KPCT43)



Used when terminating direct-vent (sealed-combustion) systems, with direct-vent models that require a 3" intake and a 4" exhaust. This concentric termination provides the convenience of only having to make one penetration through a sidewall instead of two separate penetrations for the intake and exhaust piping. The termination includes a bird screen, restricting small animals, pests, and foreign objects from entering into the vent system. This sidewall termination is available in three different sizes, to cover all ranges of wall thicknesses.

Direct-vent Concentric Termination	
Part#	Covering wall thickness
9007680005 (TK-KPCT43-1)	3.9" – 7.1"
9007772005 (TK-KPCT43-2)	6.9" – 10.1"
9007773005 (TK-KPCT43-3)	9.8" – 13.0"

WARNING FOR INSTALLATIONS

FOR YOUR SAFETY, READ BEFORE INSTALLATION:

Do not install the Hydro-Smart 115 where water, debris or flammable vapors may get into the flue terminal. This may cause damage to the Hydro-Smart 115 and void the warranty.



Prohibited

Do not install next to a dryer or any source of airborne debris that can be trapped inside the combustion chamber, unless the system is direct vented.

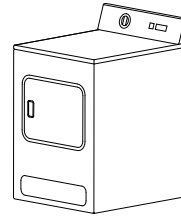



Hydro-Smart 115 is prohibited and not recommends to be installed in an attic due to safety issues.



Prohibited

HIGH-ALTITUDE INSTALLATIONS

Check the elevation where your water heater is installed. Set dipswitches shown in the table below depending on the altitude.

Altitude	0 to 2,000 ft (DEFAULT)	2,000 to 4,000 ft	4,000 to 6,000 ft	Over 6,000 ft
Switch No.3	OFF	ON	OFF	Consult Hydro-Smart at 763- 331-3066
Switch No.4	OFF	OFF	ON	
				



The dark squares indicate the direction the dipswitches should be set to.

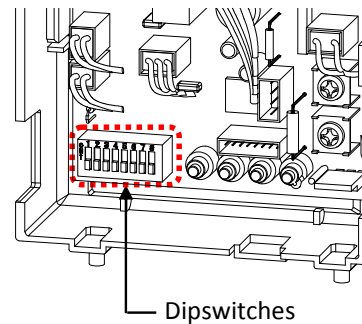

VENTING INSTRUCTIONS

-General-



Improper venting of this appliance can result in excessive levels of carbon monoxide which can result in severe personal injury or death.

Improper installation can cause nausea or asphyxiation, severe injury or death from carbon monoxide and flue gases poisoning. Improper installation will void product warranty.



When installing the vent system, all applicable national and local codes must be followed. If you install thimbles, fire stops or other protective devices and they penetrate any combustible or noncombustible construction, be sure to follow all applicable national and local codes.

The water heater must be vented in accordance with the section "Venting of Equipment" of the latest edition of the National Fuel Gas Code: ANSI Z223.1/NFPA 54 in the United States and/or Section 7 of the CAN/CSA B149.1 Natural Gas and Propane Installation Code in Canada, as well as applicable local building codes.

Hydro-Smart recommends the "T-Vent" line manufactured by TAKAGI (Refer to "T-Vent" brochure for details). However, the following are also UL listed manufacturers: ProTech Systems Inc. (FasNSeal), Flex-L Inc., Z-Flex Inc. (Z-Vent III), Metal-Fab Inc., and Heat-Fab Inc. (Saf-T Vent).

General rules for venting water heaters are:

- Place the water heater as close as possible to the vent terminator.
- The vent collar of the water heater must be fastened directly to an unobstructed vent pipe.
- Do not weld the vent pipe to the water heater's vent collar.
- Do not cut the vent collar of the unit.
- The vent must be easily removable from the top of the water heater for normal service and inspection of the unit.
- The water heater vent must not be connected to any other gas appliance or vent stack.
- Avoid using an oversized vent pipe or using extremely long runs of the pipe.
- For rooftop venting, a rain cap or other form of termination that prevents rain water from entering into the water heater must be installed.
- Do not common vent or connect any vent from other appliances to the water heater vent.

General rules for vent terminations:

- Avoid locating the water heater vent terminator near **any air intake devices**. These fans can pick up the exhaust flue products from the water heater and return them to the building. This can create a health hazard.
- Locate the vent terminator so that it cannot be blocked by any debris, at any time. Most codes require that the terminator be at least 12 inches above grade, but the installer may determine if it should be higher depending on the job site condition and applicable codes.
- A proper sidewall terminator is recommended when the water heater is vented through a sidewall.
- Regarding the clearances from the exhaust terminator to the air inlet or opening, refer to the next few pages.

-Exhaust venting-

This is a Category III appliance and must be vented accordingly. The vent system must be sealed air tight. All seams and joints **without gaskets** must be sealed with high heat resistant silicone sealant or UL listed aluminum adhesive tape having a minimum temperature rating of 350°F. For best results, a vent system should be as short and straight as possible.

- This water heater is a Category III appliance and must be vented accordingly with any 4" vent approved for use with Category III or Special BH type gas vent.
- **Follow the vent pipe manufacturer's instructions when installing the vent pipe.**
- **Do not common vent this appliance with any other vented appliance** (Do not terminate vent into a chimney. If the vent must go through the chimney, the vent must run all the way through the chimney with Category III approved or Special BH vent pipe).
- When the horizontal vent run exceeds 5 ft., support the vent run at 3 ft. intervals with overhead hangers.
- The maximum length of exhaust vent piping must not exceed 50 ft. (deducting 5 ft. for each elbow used in the venting system). Do not use more than 5 elbows.

Diameter	Max. No. of Elbow	Max. Vertical and Horizontal (Total) Vent Length
4"	5	50 ft.

*For each elbow added, deduct 5 ft. from max. Vent length.

No. of Elbows	Max. Vertical or Horizontal Length
0	50 ft.
1	45 ft.
2	40 ft.
5	25 ft.

-Venting Illustrations-

For details of the optional items, refer to the Installation manual for each Optional item.

Horizontal Installation Diagram

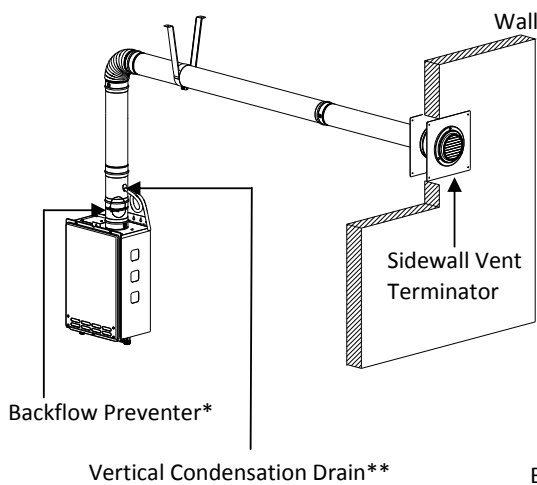

Vertical Installation Diagram

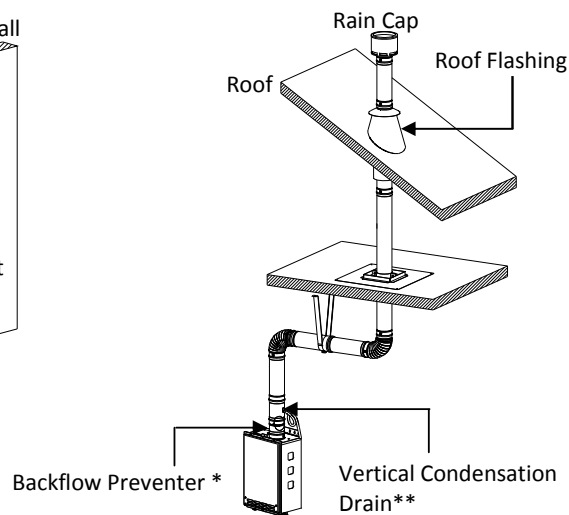

**Horizontal Installation Diagram
(With direct-venting)**

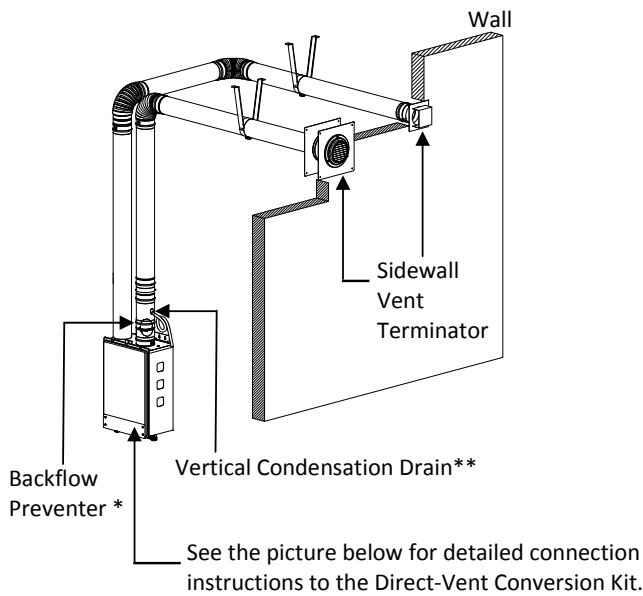

**Vertical Installation Diagram
(With direct-venting)**

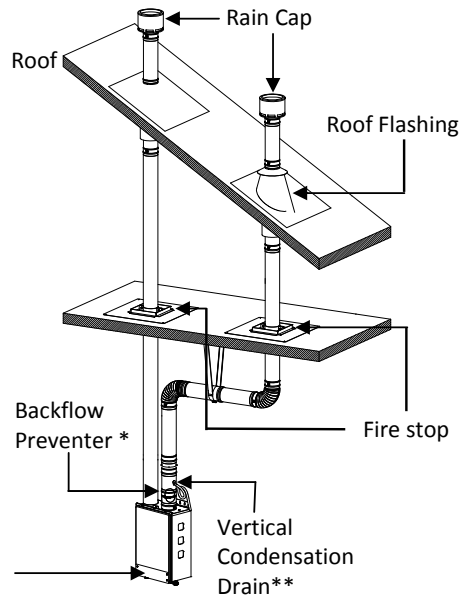

*Backflow Preventer (Recommended for freezing weather conditions: 36°F and below)

**Vertical Condensation Drain must be installed accordance with local codes.

**Horizontal Installation Diagram
With Direct-Vent Concentric
Termination**

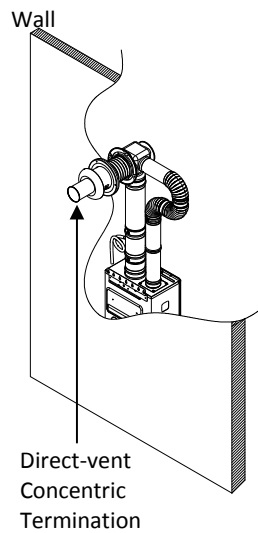

**Installation Diagram of Direct-Vent
Conversion Kit with water heater**

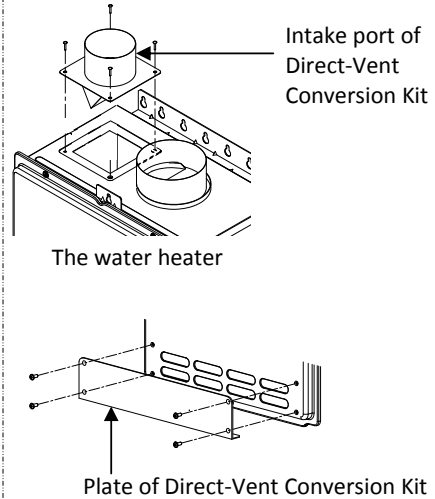

-Vent termination clearances-

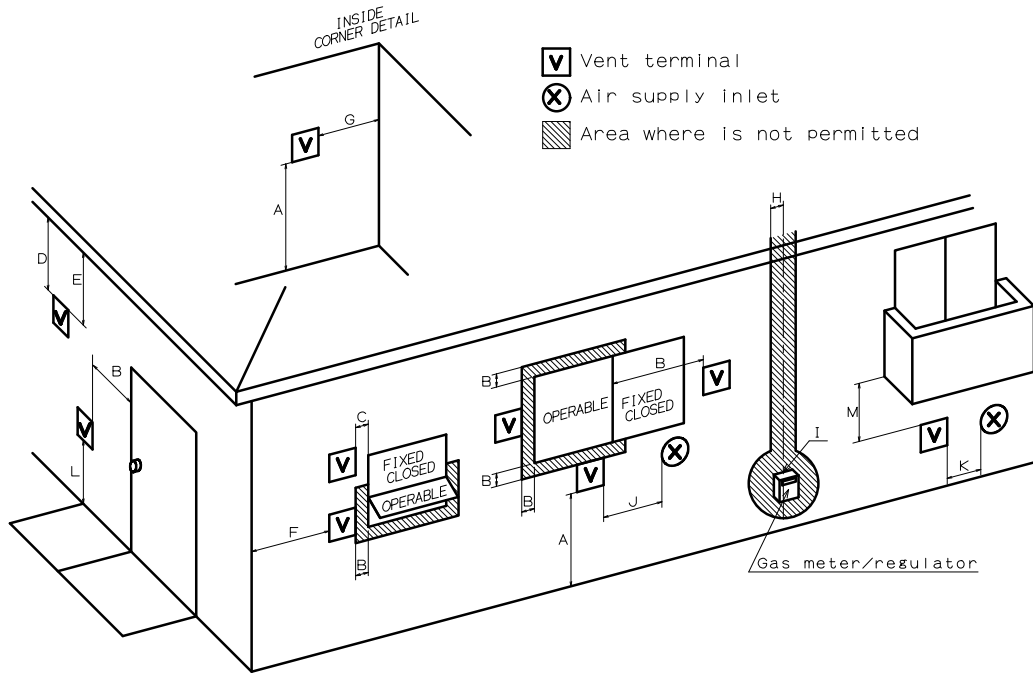

		Canada	U.S.A	
		Direct vent and other than Direct Vent	Direct vent	Other than Direct Vent
A	Clearance above grade, veranda, porch, deck, or balcony.	1 foot	1 foot	1 foot
B	Clearance to window or door that may be opened.	3 feet	1 foot	4 feet from below or side opening. 1 foot from above opening.
C	Clearance to permanently closed window	*	*	*
D	Vertical clearance to ventilated soffit located above the vent terminator within a horizontal distance of 2 feet (61cm) from the center line of the terminator.	*	*	*
E	Clearance to unventilated soffit	*	*	*
F	Clearance to outside corner	*	*	*
G	Clearance to inside corner	*	*	*
H	Clearance to each side of center line extended above meter/regulator assembly	3 feet	*	*
I	Clearance to service regulator vent outlet.	3 feet	*	*
J	Clearance to non-mechanical air supply inlet to building or the combustion air inlet to any other application.	3 feet	1 foot	4 feet from below or side opening. 1 foot from above opening.
K	Clearance to mechanical air supply inlet.	6 feet	3 feet	3 feet
L	Clearance above paved sidewalk or paved driveway located on public property.	7 feet	*	7 feet
M	Clearance under veranda, porch deck, or balcony.	1 foot	*	*

*For clearances not specified in ANSI Z223.1 / NFPA 54 or CAN/CSA-B149.1, please use clearances in accordance with local installation codes and the requirements of the gas supplier.



Please follow all local and national codes in regards to proper termination clearances. In the absence of such codes, the following clearances can be used as guidelines. Local codes supersede these guidelines.

For sidewall terminations

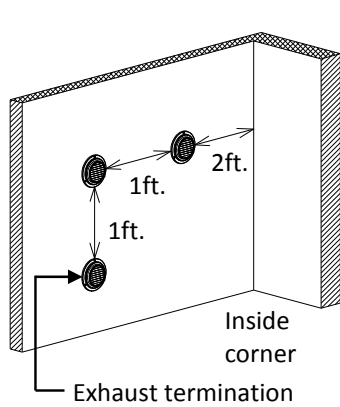

For multiple sidewall exhaust terminations (e.g. multi-unit systems), an exhaust termination must be at least 1 ft. away from another exhaust termination. An exhaust termination must also be at least 2 ft. away from an inside corner (if the adjacent wall is less than 2 ft. of length, the minimum required distance away from the inside corner will be equal to the length of that adjacent wall).

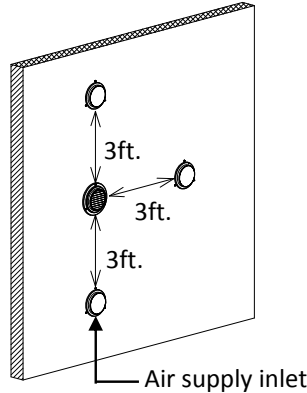

For direct-vent sidewall terminations that use two separate penetrations for the intake and exhaust, distance the intake and exhaust terminations at least 3 ft. away from each other, no matter the orientation.

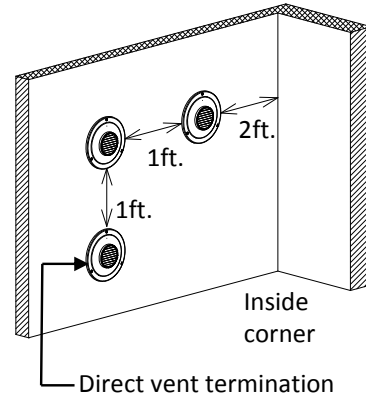

For multiple-unit, direct-vent sidewall terminations that combine the intake and exhaust into a single penetration, space each direct-vent termination at least 1 ft. away from each other, no matter the orientation. A direct-vent termination must also be at least 2 ft. away from an inside corner (if the adjacent wall is less than 2 ft. of length, the minimum required distance away from the inside corner will be equal to the length of that adjacent wall).

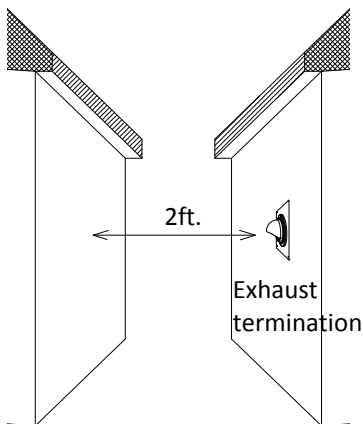

Exhaust and/or direct-vent sidewall terminations should be at least 2 ft. away from an opposite surface/wall. Do not place the termination directly in front of an opening into a building.

For rooftop terminations

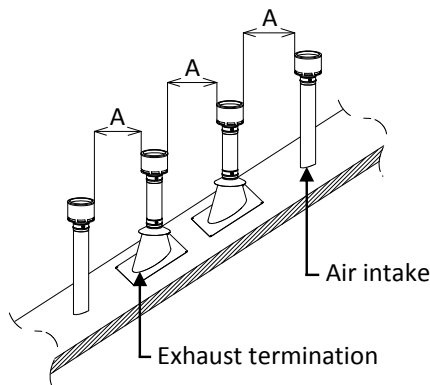

A: In accordance with local codes

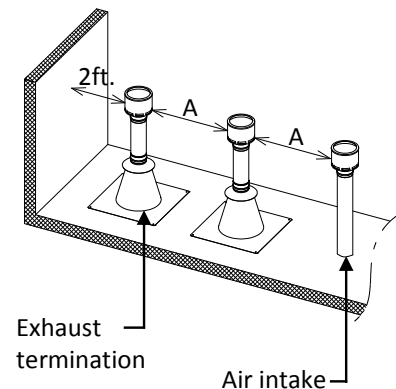

For multiple-unit rooftop terminations (whether for standard indoor or direct-vent installations) space all exhaust and intake terminations in accordance with local codes. An exhaust termination must be spaced from a wall or surface in accordance with local codes as well. In the absence of such a code, an exhaust termination must be a horizontal distance of at least 2 ft. away from a wall or surface.

GAS SUPPLY AND GAS PIPE SIZING

-General-



- Check that the type of gas matches the rating plate first.
- Ensure that any and all gas regulators used are operating properly and providing gas pressures within the specified range shown below. Excess gas inlet pressure may cause serious accidents.
- Conversion of this unit from natural gas to propane or vice versa will void all warranty. Contact your local distributor to get the correct unit for your gas type. **The manufacturer is not liable for any property and/or personal damage resulting from gas conversions.**

- The minimum and maximum inlet gas pressures are:

Gas type	Inlet gas pressure
Natural Gas	Min. 5.0" WC – Max. 10.5" WC
Propane	Min. 8.0" WC – Max. 14.0" WC

- Gas pressure above this specified range for the water heater and/or insufficient gas volume will adversely affect performance. These pressures are measured when the water heater is in full operation.
- Inlet gas pressure must not exceed the above maximum values; gas pressure above the specified range will cause dangerous operating conditions and damage to the unit.
- Until testing of the main gas line supply pressure is completed, ensure the gas line to the water heater is disconnected to avoid any damage to the water heater.

-Gas connections-

1. Install a manual gas shut-off valve between the water heater and the gas supply line.
2. When the gas connections are completed, it is necessary to perform a gas leak test (see below) either by applying soapy water to all gas fittings and observing for bubbles or by using a gas leak detection device.
 - The water heater and its individual shutoff valve must be disconnected from the gas supply piping system during any pressure testing of that system at test pressures in excess of 1/2 psi (3.5 kPa).
 - The water heater must be isolated from the gas supply piping system by closing its individual manual shutoff valve during any pressure testing of the gas supply piping system at test pressures equal to or less than 1/2 psi (3.5kPa).
3. Always purge the gas line of any debris and/or water before connecting to the gas inlet.

NOTICE

Size the gas pipe appropriately to supply the necessary volume of gas required for the water heater using ANSI233.1/NFPA 54 in the USA or CAN/CSA B149.1 in Canada or local codes. Otherwise, flow capabilities and output temperatures will be limited.

-Natural Gas Supply Piping-

Maximum Delivery Capacity of Cubic Feet of Gas per Hour of IPS Pipe Carrying Natural Gas of 0.60 Specific Gravity Based on Pressure Drop of 0.5" WC

Based on Energy Content of 1,000 BTU/Cubic Ft.: The water heater requires 140 Cubic Ft./hr.

Unit: Cubic Feet per Hour

Pipe Size	Length												
Diameter	10'	20'	30'	40'	50'	60'	70'	80'	90'	100'	125'	150'	200'
¾"	363	249	200	171	152	138	127	118	111	104	93	84	72
1"	684	470	377	323	286	259	239	222	208	197	174	158	135
1 ¼"	1,404	965	775	663	588	532	490	456	428	404	358	324	278
1 ½"	2,103	1,445	1,161	993	880	798	734	683	641	605	536	486	416
2"	4,050	2,784	2,235	1,913	1,696	1,536	1,413	1,315	1,234	1,165	1,033	936	801

-Propane (LP) Supply Piping-

Maximum Capacity of Propane (LP) Based on 11" WC supply pressure at a 0.5" WC pressure drop

Unit: kBTU per Hour

Pipe Size	Length												
Diameter	10'	20'	30'	40'	50'	60'	70'	80'	90'	100'	125'	150'	200'
¾"	567	393	315	267	237	217	196	185	173	162	146	132	112
1"	1,071	732	590	504	448	409	378	346	322	307	275	252	213
1 ¼"	2,205	1,496	1,212	1,039	913	834	771	724	677	630	567	511	440
1 ½"	3,307	2,299	1,858	1,559	1,417	1,275	1,181	1,086	1,023	976	866	787	675
2"	6,221	4,331	3,465	2,992	2,646	2,394	2,205	2,047	1,921	1,811	1,606	1,496	1,260

For more information, please see the below.

Gas Sizing Example (Natural Gas)

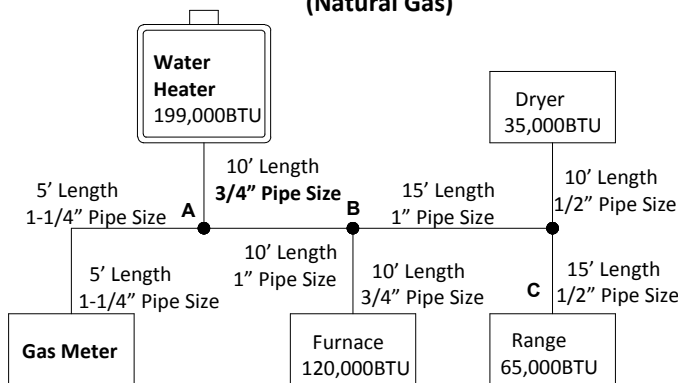

Based on Energy Content of 1,000BTU/Cubic Ft:

Divide each appliance's BTU requirement by 1,000BTU to get the appliances Cubic Ft. requirement.

Take into account the distance the appliance is from the gas meter, look in the above gas chart to properly size the line.

For sections of the gas line supplying gas to more than one appliance (Ex: Point A to Point B), add up the cubic ft. requirements of the appliances that are being supplied by that section, and size to the farthest appliance.

For Example: The section from A to B supplies gas to the furnace, range, and dryer. Adding up the BTU requirements and dividing by 1,000 yields a cubic ft. requirement of 220 cubic ft. of gas. The farthest appliance is the range, which is 50 ft. away from the meter. Looking at the above chart, and under the column of 50ft., Section A to B needs to be 1" in order to supply 220 cubic ft.

-Measuring inlet gas pressure-



1. Turn off all electric power to the water heater if service is to be performed.
2. Turn the manual gas valve located on the outside of the unit clockwise \cup to the off position.

The water heater cannot perform properly without sufficient inlet gas pressure. Below are instructions on how to check the inlet gas pressure. **THIS IS ONLY TO BE DONE BY A LICENSED PROFESSIONAL.**

1. Shut off the manual gas valve on the supply gas line.
2. Remove the screw for the pressure port located on the gas inlet of the water heater shown in the diagram to the right.
3. Connect the manometer to the pressure port.
4. Re-open the manual gas valve. Check to see that there are no gas leaks. Open some of the fixtures that use the highest flow rate to turn on the water heater.
5. Check the inlet gas pressure. When the water heater is on maximum burn, the manometer should read from 5.0" to 10.5" WC for Natural gas, from 8.0" to 14.0" WC for Propane.

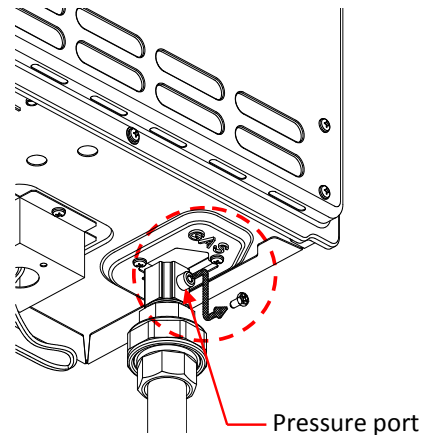

WATER CONNECTIONS



- Do not use this water heater if any part has been submerged under water. Immediately call a licensed professional to inspect the water heater to replace any damaged parts.
- Do not reverse the hot outlet and cold inlet connections to the water heater. This will not properly activate the water heater.

All pipes, pipe fittings, valves and other components, including soldering materials, must be suitable for potable water systems.

1. A manual shut off valve must be installed on the cold water inlet to the water heater between the main water supply line and the water heater.
2. In addition, a manual shut off valve is also recommended on the hot water outlet of the unit. If the water heater is installed within, or subjected to, a closed loop water system, a thermal expansion tank must be installed.
3. Before installing the water heater, flush the water line to remove all debris, and after installation is complete, purge the air from the line. Failure to do so may cause damage to the heater.
4. There is a wire within the cold inlet to trap debris from entering your heater. This will need to be cleaned periodically to maintain optimum flow.

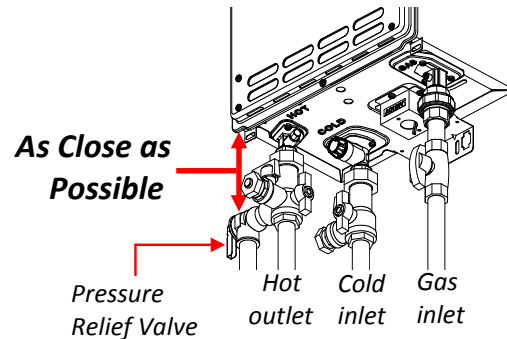

-Pressure relief valve-

The water heater has a high-temperature shut off switch built in as a standard safety feature (called a Hi-Limit switch) therefore a **“pressure only”** relief valve is required.

- This unit does not come with an approved pressure relief valve.
- An approved pressure relief valve must be installed on the hot water outlet.
- The pressure relief valve must conform to ANSI Z21.22 or CAN 1-4.4 and installation must follow local code.
- The discharge capacity must be at least 140,000 BTU/h.
- The pressure relief valve needs to be rated for a maximum of 150 psi.
- The discharge piping for the pressure relief valve must be directed so that the hot water cannot splash on anyone or on nearby equipment.
- Attach the discharge tube to the pressure relief valve and run the end of the tube to within 6" from the floor. This discharge tube must allow free and complete drainage without any restrictions.
- If the pressure relief valve installed on the water heater discharges periodically, this may be due to a defective thermal expansion tank or defective pressure relief valve.
- The pressure relief valve must be manually operated periodically to check for correct operation.
- No valve must be placed between the relief valve and the water heater.

ELECTRICAL CONNECTIONS



Follow the electrical code requirements of the local authority having jurisdiction. In the absence of such requirements, follow the latest edition of the National Electrical Code ANSI/NFPA 70 in the U.S. or the latest edition of CSA C22.1 Canadian Electrical Code, Part 1, in Canada.



When servicing or replacing parts within the water heater, label all wires prior to disconnection to facilitate an easy and error-free reconnection. Wiring errors can cause improper and dangerous operation. Verify proper operation after servicing.

The indoor model comes with a power plug instead of a junction box. The following procedure is for outdoor models only.

1. The water heater must be electrically grounded. Do not attach the ground wire to either the gas or the water piping.
2. The water heater requires **120 VAC / 60 Hz electrical power supply that is properly grounded.**
 - A proper disconnect (i.e. on/off switch, power plug, etc.) controlling the main power to the water heater must be provided for service reasons. (Must comply with local codes).
 - Connect the power supply to the water heater exactly as shown in the wiring diagram;
3. A green screw is provided in the junction box to ground the connection.
4. Can be hardwired or wired to a plug-in.
5. The use of a surge protector is recommended in order to protect the unit from power surges.

Outdoor model only

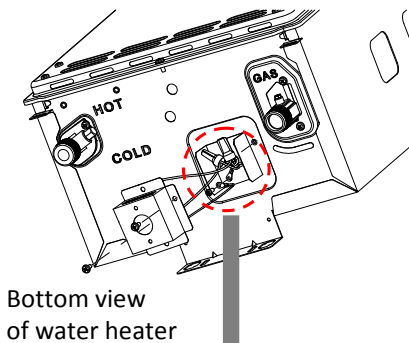

Bottom view of water heater

Indoor model only

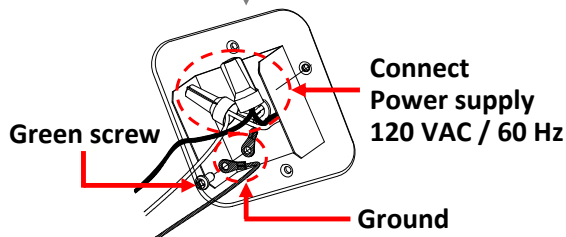
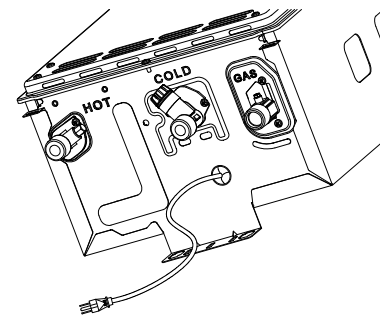

View of electrical connections of water heater

REMOTE CONTROLLER CONNECTIONS

<How to connect the remote controller to the water heater>

1. Disconnect power supply from the water heater.
2. Take off the water heater's front cover.
3. Locate the remote controller terminal, pictured below (located around the lower right-hand side of the computer board).
4. Open the plastic cover of the remote controller, and then attach the two fork terminals to connector base of the backside the remote controller with two screws. Make sure the terminals are firmly fixed.
5. Pull the remote's wires through the hole at the bottom of the water heater's casing.
6. Properly attach the remote's wires to the remote controller terminal on the computer board.
(No polarity)

***Do NOT jump or short-circuit the wires or computer will be damaged.**

7. Replace Front Cover securely.
8. Wires used for the remote controller connection must be:
 - Minimum 18AWG wire (No polarity)
 - Maximum 400 feet long

*For detailed connection instructions to the remote controller, refer to the instructions that are packaged with the remote controller.

Remote controller terminal inside water

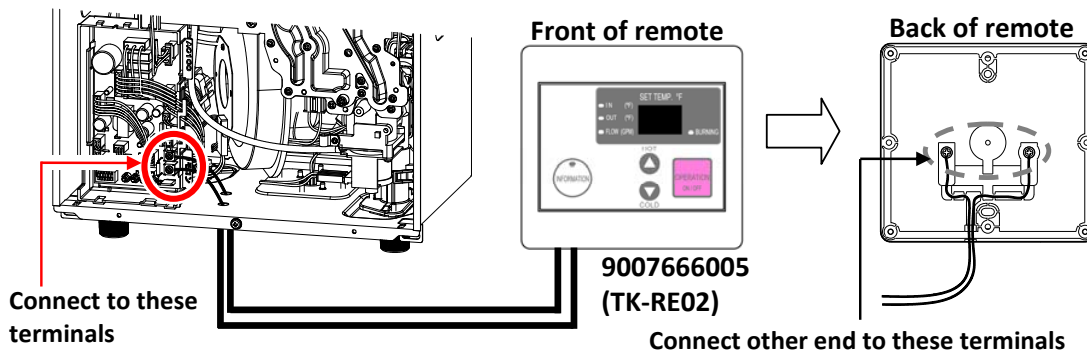

APPLICATIONS

-Space-Heating Applications-



- In order to purge air in water pipes within a closed-loop system, an air vent and air separator should be installed in to the system. Required circulation flow rates are labeled next to each application diagram. These flow rate requirements must be followed.
- Toxic chemicals used in boiler treatments such as alcohol, glycerol and glycol groups must not be introduced into the system if the system incorporates an open-loop potable water system.
- The water heater can be used to supply potable water and space heating and shall not be connected to any heating system or component(s) previously used with non-potable water where any chemicals were added to the water heating appliances.
- When the system requires water for space heating at temperatures higher than required for other uses, a means such as a mixing valve shall be installed to temper the water for those other uses in order to reduce scald hazard potential.
- Water temperature over 125 °F (52°C) can cause severe burns instantly or death from scalds.
- Chemicals such as diluted Glycol can be used for radiant floor, Hydro/fan coil air or Baseboard heating only. The diluted solution of glycol must contain between 25 and 55 % of Glycol. Be aware that in closed-loop glycol systems, low pressure in the heat exchanger can cause low-temperature boiling, resulting in excessive noise and damage to the water heater. Consult with the glycol maker for specifications prior to use.

-Dual-purpose hot water heating- (Domestic and Space Heating):

Diagrammatic Layout of Radiant Heating and
Domestic Water Heater Per Mass. Code

All water piping should be insulated
in accordance with 780 CMR
(Massachusetts energy code)

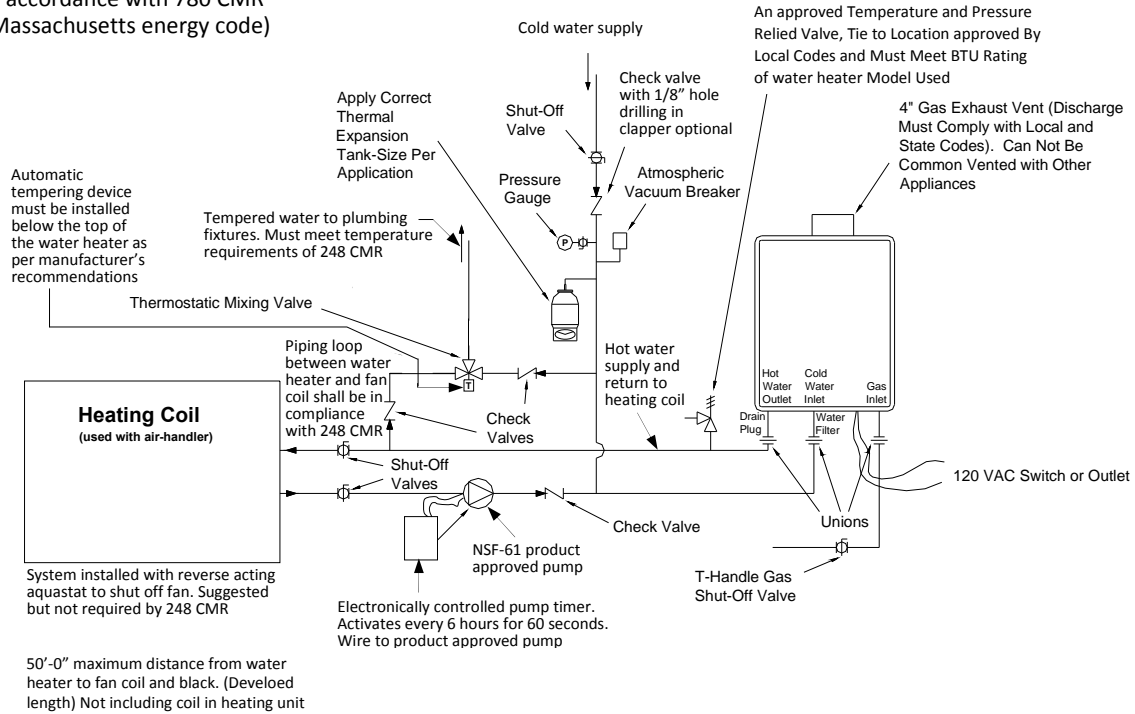

The circulation pump is to provide no less than 2 GPM and no more than 4 GPM through each activated unit in the system.

NOTICE

- **Priority Control Devices** such as a flow switch, an Aquastat or other electronic controller can be used to prioritize the domestic water system over the heating system.
- Follow all local codes, or in the absence of local codes, follow the most recent edition of the National Standard Code, ANSI Z21.10.3.
- This illustration is a concept design only. The reference to the 1/8th hole in check is only for the State of Massachusetts. There are a wide variety of variations to the application of controls and equipment presented. Designers must add all necessary safety and auxiliary equipment to conform to code requirements and design practice. For more details, contact the manufacturer.

INITIAL OPERATION





FOR YOUR SAFETY, READ BEFORE OPERATING

- Check the **GAS and WATER CONNECTIONS** for leaks before firing unit for the first time.
- Open the main gas supply valve to the unit using only your hand to avoid any spark. Never use tools. If the knob will not turn by hand, do not try to force it; call a qualified service technician. Forced repair may result in a fire or explosion due to gas leaks.
- Be sure to check for the presence of leaking gas toward the bottom of the unit because some gases are heavier than air and may settle towards the floor.
- Check the **GAS PRESSURE**. Refer to p. 19.
- Do not try to light the burner manually. It is equipped with an electronic ignition device which automatically lights the burner.
- Check for **PROPER VENTING and COMBUSTIBLE AIR** to the water heater.
- Purge the **GAS and WATER LINES** to remove any air pockets.
- Do not use this water heater if any part has been submersed under water. Immediately call a qualified service technician to inspect the water heater and to replace any damaged parts.

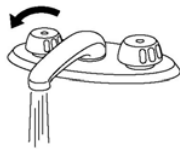

IF YOU SMELL GAS:

- Do not try to start the water heater.
- Do not touch any electric switches; do not use any phone in your building.
- Immediately call your gas supplier from a neighbor's phone. Follow the gas supplier's instructions.
- If you cannot reach your gas supplier, call the fire department.

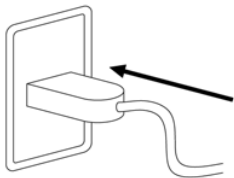
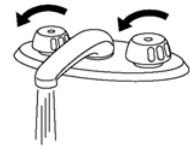
<p>1. Refer to p. 31 for instructions.</p> 	<p>2. Fully open the manual water control valve on the water supply line.</p> 	<p>3. Open a hot water tap to verify that water is flowing to that tap.</p>  <p>Then close the hot water tap.</p>
<p>4. Fully open the manual gas control valve installed.</p> 	<p>5. Turn on the 120 volt 60 Hz power supply to the water heater.</p> 	<p>6. Now you are ready to enjoy hours of endless hot water.</p> 

Owner's Guide

OPERATING SAFETY

FOR YOUR SAFETY READ BEFORE OPERATING

WARNING: If you do not follow these instructions exactly, a fire or explosion may result causing property damage, personal injury or loss of life.

- A. This water heater does not have a pilot. It is equipped with an ignition device that automatically lights the burner. Do not try to light the burner by hand.
- B. BEFORE OPERATING smell all around the water heater area for evidence of leaking gas. Be sure to smell next to the floor because some gas is heavier than air and will settle on the floor.

WHAT TO DO IF YOU SMELL GAS.

- Do not try to light any appliance.
 - Do not touch any electric switch; do not use any phone in your building.
 - Immediately call your gas supplier from a neighbor's phone. Follow the gas supplier's instructions.
 - If you cannot reach your gas supplier, call the fire department.
- C. Use only your hand to turn the gas valve knob. Never use tools. If the knob will not turn by hand, don't try to repair it, call a qualified service technician. Force or attempted repair may result in a fire or explosion.
 - D. Do not use this water heater if any part has been under water. Immediately call a qualified service technician to inspect the water heater and to replace any damaged parts.

OPERATING INSTRUCTIONS

1. **STOP!** Read the safety information above or in the Owners Manual.
2. Turn off all electric power to the water heater.
3. Do not attempt to light the burner by hand.
4. Turn the manual gas valve located on the outside of the unit clockwise ⤵ to the off position.
5. Wait five (5) minutes to clear out any gas. If you then smell gas. STOP! Follow "B" in the safety information above on this label. If you don't smell gas, go to next step.
6. Turn the manual gas valve located on the outside of the unit counter clockwise ⤴ to the ON position.
7. Turn on all electrical power to the water heater.
8. If the water heater will not operate, follow the instructions "to Turn Off Gas to water heater" and Call your service technician or gas supplier.

TO TURN OFF GAS TO APPLIANCE

1. Turn off all electric power to the water heater if service is to be performed.
2. Turn the manual gas valve located on the outside of the unit clockwise ⤵ to the off position.

DANGER



Vapors from flammable liquids will explode and catch fire causing death or severe burns.

Do not use or store flammable products such as gasoline, solvents or adhesives in the same room or area near the water heater.

Keep flammable products:

1. Far away from heater
2. In approved containers
3. Tightly closed
4. Out of children's reach

Vapors:

1. Cannot be seen
2. Vapors are heavier than air
3. Go a long way on the floor
4. Can be carried from other rooms to the main burner by air currents

WARNING: Do not install water heater where flammable products will be stored.

Read and follow water heater warnings and instructions. If owner's manual is missing, contact Hydro-Smart.

WARNING

The outlet hot water temperature of the water heater is factory set at 122°F (50°C). Use this heater at your own risk. The set outlet water temperature can cause severe burns instantly or death from scalds. Test the water before bathing or showering. Do not leave children or an infirm person in the bath unsupervised.

DANGER



Hot Water temperature over 125°F (52°C) can cause severe burns instantly or death from scalding. Children, disabled and elderly are at the highest risk of being scalded. Feel water temperature before bathing or showering. Temperature limiting valves are available. Ask a professional person.

WARNING: California Proposition 65 lists chemical substances known to the state to cause cancer, birth defects, death, serious illness or other reproductive harm. This product may contain such substances, be their origin from fuel combustion (gas, oil) or components of the product itself.

NORMAL OPERATION

GENERAL



WARNING

- Hot Water temperatures over 125°F (52°C) can cause severe burns instantly or death from scalding.
- The outlet hot water temperature of the water heater is factory set at 122°F (50°C).

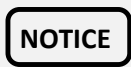
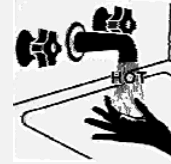

NOTICE

- Flow rate to activate the water heater : 0.5 gallons per minute at the default set temperature
- Flow rate to keep the water heater running : 0.4 gallon per minute

OPERATION

<Set temperature>

1. Turn on the 120 VAC power supply to the water heater.
2. Press the "**OPERATION**" button on the remote in order to turn the remote controller on. It shows the set temperature on its display as shown the picture to the below.
3. Press the "**HOT**" button or the "**COLD**" button to set the temperature setting of the unit.
4. You can set the temperature from 99°F (38°C) to 167°F (75°C).

<Exterior view of the remote controller>

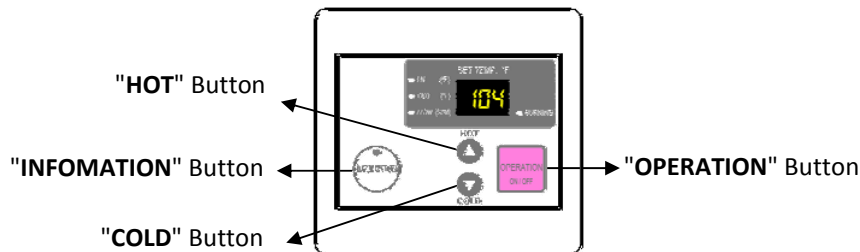

<The temperature options>

99	100	102	104	106	108	110	111	113	115	117	122	131	140	158	167
----	-----	-----	-----	-----	-----	-----	-----	-----	-----	-----	-----	-----	-----	-----	-----



CAUTION

Temperature above 122°F (50°C) can cause severe burns or death from scalding. Children, disabled and the elderly are at high risk of being injured.

TEMPERATURE SETTINGS

-Without remote controller-

There are 4 temperatures that you can select from by changing the dipswitch settings on the computer board without the remote controller. See the table below.

Temperatures available			
113°F	122°F	131°F	140°F

For detailed dipswitch settings for each temperature, refer to the next page.

- The temperature has been preset at the factory to 122°F (50°C).
- If temperatures other than the ones listed above are required, the remote controller can provide several more temperature options. Refer to p. 9 for a list of available temperatures on the remote controller.
- This water heater is an on-demand, tankless water heater designed to efficiently supply endless hot water without reference to temperature settings.

-Dipswitch settings for each temperature on the computer board-

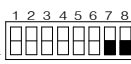
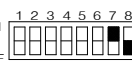
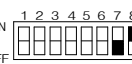
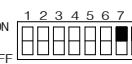
Temperature Settings			
113°F ON (45°C) OFF 	122°F ON (50°C) DEFAULT OFF 	131°F ON (55°C) OFF 	140°F ON (60°C) OFF 



WARNING

- Turn off the power supply to the water heater before changing the dipswitch settings.
- Only change the switches with the dark squares. The dark squares indicate which direction the dipswitch should be set to.

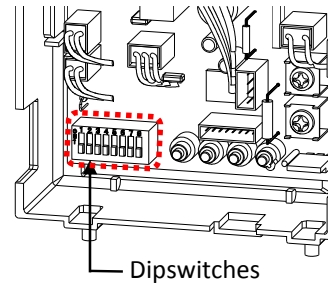

FLOW

- The flow rate through the water heater is limited to a maximum of 6.6 GPM.
- The temperature setting, along with the supply temperature of the water will determine the flow rate output of the unit.
- Please refer to the temperature vs. gallons per minute chart on p. 41 to determine the likely flow rates based on your local ground water temperature and your desired outlet water temperature.
- Based on the United States Department of Energy method of testing water heater output, the water heater is rated for 172 gallons per hour (GPH) or 2.9 gallons per minute (GPM) for Natural Gas, and 184 GPH or 3.1 GPM for Propane, when raising the water temperature by 77°F (from 58°F to 135°F).
- Refer to the table to the top right for typical household plumbing fixture flow rates to determine what the water heater can do in a household application.

Household Flow Rates	
Appliance / Use	Flow Rate (GPM)
Lavatory Faucet	1.0
Bath Tub	4.0 – 10.0
Shower	2.0
Kitchen Sink	1.5
Dishwasher	1.5
Washing machine	4.0

FREEZE PROTECTION SYSTEM

- This unit comes equipped with heating blocks to protect it against damages associated with freezing.
- For this freeze protection system to operate there has to be electrical power to the unit. Damage to the heat exchanger caused by freezing temperatures due to power loss is not covered under the warranty. In cases where power losses can occur, consider the use of a backup power supply.
- The freeze protection system will activate when the surrounding and/or outside temperatures drop below 36.5°F (2.5°C).
- For the Hydro-Smart 115 models:
 - In any areas subject to freezing temperatures, Hydro-Smart highly recommends an indoor installation with an indoor model. In such an installation, freezing issues can only occur if cold air enters through the venting into the heat exchanger, whether by negative pressures within the installation location or by strong outside winds.
 - Hydro-Smart also highly recommends the use of a back flow vent damper to minimize the amount of cold air entering through the exhaust venting when the water heater is off.
- It is the installer's responsibility to be aware of freezing issues and take all preventative measures. Hydro-Smart will not be responsible for any damage to the heat exchanger as a result of freezing.
- If you will not be using your heater for a long period of time:
 1. Completely drain the unit of water. Refer to p. 31.
 2. Disconnect power to your heater.

This will keep your unit from freezing and being damaged.



CAUTION

Only pipes within the water heater are protected by the freeze protection system. Any water pipes (hot or cold) located outside the unit will not be protected. Properly protect and insulate these pipes from freezing.

MAINTENANCE AND SERVICE



Turn off the electrical power supply and close the manual gas shutoff valve and the manual water control valve before servicing.

- Be sure that all openings for combustion and ventilation air are not blocked.
- The venting system should be checked annually for any leaks, corrosion, blockages or damage.
- The burner should be checked annually for dust, lint, grease or dirt.
- Keep the area around the water heater clear. Remove any combustible materials, gasoline or any flammable vapors and liquids.
- In accordance with all local codes and common safety practices, Water discharged from the pressure relief valve can cause severe burns instantly from scalding. **DO NOT** touch the pressure relief valve.
- If the relief valve discharges periodically, it may be due to thermal expansion in a closed water supply system. Contact the water supplier or local plumbing inspector on how to correct this situation.
- Visual check of burner flames (see below) through the burner window in the burner assembly located at the middle of the water heater.

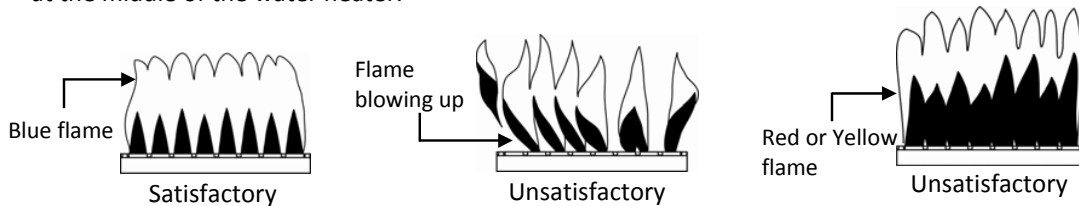

Hydro-Smart recommends having the unit checked once a year or as necessary by a licensed technician. If repairs are needed, any repairs should be done by a licensed technician.

UNIT DRAINING

1. Close the manual gas shut off valve.
2. Turn off power to the unit and wait a couple of seconds. Turn on again.
3. Wait 30 seconds, and then turn off power to the unit, yet again.
4. Close the water shut off valve.
5. Open all hot water taps in the house. When the residual water flow has ceased, close all hot water taps.
6. Have a bucket or pan to catch the water from the unit's drain plugs. **Unscrew** the two drain plugs (Large and small) to drain all the water out of the unit.
7. Wait a few minutes to ensure all water has completely drained from unit.
8. Securely screw the drain plugs back into place. **Hand-tighten only.**

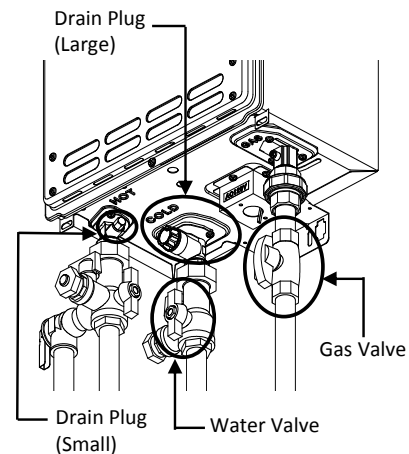

TROUBLESHOOTING

GENERAL

	PROBLEM	SOLUTIONS
-TEMPERATURE and AMOUNT OF HOT WATER-	It takes long time to get hot water at the fixtures.	<ul style="list-style-type: none"> • The time it takes to deliver hot water from the water heater to your fixtures depends on the length of piping between the two. The longer the distance or the bigger the pipes, the longer it will take to get hot water.
	The water is not hot enough.	<ul style="list-style-type: none"> • Compare the flow and temperature. See the charts on p. 41. • Check cross plumbing between cold water lines and hot water lines. • Is the gas supply valve fully open? (p. 25) • Is the gas line sized properly? (p. 18) • Is the gas supply pressure enough? (p. 19) • Is the set temperature set too low? (p. 28-29)
	The water is too hot.	<ul style="list-style-type: none"> • Is the set temperature set too high? (p. 28-29)
	The hot water is not available when a fixture is opened.	<ul style="list-style-type: none"> • Make sure the unit has 120 VAC / 60 Hz power supply. • If you are using the remote controller, is the power button turned on? • Is the gas supply valve fully open? (p. 25) • Is the water supply valve fully open? (p. 25) • Is the hot water fixture sufficiently open to draw at least 0.5 GPM through the water heater? (p. 28) • Is the unit frozen? (p. 30) • Is there enough gas in the tank / cylinder? (For Propane models)
	The hot water turns cold and stays cold.	<ul style="list-style-type: none"> • Is the flow rate enough to keep the water heater running? (p. 28) • Does the recirculation line have enough check valves? (p. 4) • Is the gas supply valve fully open? (p. 25) • Are the fixtures clean of debris and obstructions? • Check if the flow rate is too low. (p. 28-29)
	Fluctuation in hot water temperature.	<ul style="list-style-type: none"> • Is the gas line sized properly? (p. 18) • Is the supply gas pressure sufficient? (p. 19) • Check for cross connection between cold water lines and hot water lines.

	PROBLEM	SOLUTIONS
- WATER HEATER -	Unit does not ignite when water goes through the unit.	<ul style="list-style-type: none"> • Is the flow rate over 0.5 GPM? (p. 28) • Check for reverse connection and cross connection. • If you use the remote controller, is the power button turned on? • Check if the inlet temperature is too high.
	The fan motor is still spinning after operation has stopped.	<ul style="list-style-type: none"> • This is normal. After operation has stopped, the fan motor keeps running from 15 to 70 seconds in order to re-ignite quickly, as well as purge all the exhaust gas out of the flue.
	Unit sounds abnormal while in operation	<ul style="list-style-type: none"> • Contact Hydro-Smart.
-Remote controller- (OPTIONAL)-	Remote controller does not display anything when the power button is turned on.	<ul style="list-style-type: none"> • Make sure the unit is supplied with power. • Make sure the connection to the unit is correct. (p. 22)
	An ERROR code is displayed.	<ul style="list-style-type: none"> • Please see p. 34-36.

ERROR CODES

- The units are self diagnostic for safety and convenience when trouble shooting.
- If there is a problem with the installation or the unit, depending on the model or if there is a remote controller installed, it will either display a blinking red LED, or the error code will display on the remote controller if it is installed.
- Consult with the table on the following page for the cause of each error code.

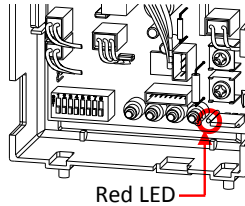

Error code on the computer board



Error code on the remote controller 9007666005 (TK-RE02)

-Single unit installations-

Example: If your unit displays the “321” error code (which signifies an inlet thermistor failure)

- **Hydro-Smart 115:** The red LED on the computer board will be blinking two times.
- **If the remote controller 9007666005 (TK-RE02) is installed:** “32” will display on the screen in its entirety.

-FAULT ANALYSIS OF ERROR CODES-

If the error code displayed on the computer board of the Water heater or remote controller, please check the following. After checking, **Consult with the manufacturer.**

Red LED	Remote	Malfunction description	Diagnosis
One Time	03	Incorrect dipswitch setting	<ul style="list-style-type: none"> • Check the dipswitch settings on the PCB. (Part #701)
Five Times	10	Warning for the "991" error code	<ul style="list-style-type: none"> • Check the gas type of the water heater. • Check if there is any blockage in the intake air and/or exhaust. • If the water heater is installed as a direct-vent system, check whether there is enough distance between the intake air terminal and the exhaust terminal. • Check the altitude/elevation of area of where the water heater installed. • Check if there is grease and/or dirt in the burner (Part #101) and the fan motor (Part #103), especially if the water heater has been installed in a contaminated area.
Three Times	11	Ignition failure	<ul style="list-style-type: none"> • Check if the Hi-limit switch (Part #412) is properly functioning. • Check for connection/breakage of wires (Part #413, 708, 709, 710, 712), burn marks on the computer board (Part #701), and/or soot on the flame rod (Part #108). • Check if there is a buzzing spark ignition sound coming from the burner (Part #101) when water heater prepares for combustion. • Listen for the double "clunk" sound coming from gas valve assembly (Part #102) when water heater goes into combustion. • Check if there is leaking from heat exchanger. (Part #401)
Three Times	12	Loss of flame	<ul style="list-style-type: none"> • Check if the Hi-limit switch (Part #412) is properly functioning. • Check for connection/breakage of wires (Part #413, 708, 709, 710, 712), burn marks on the computer board (Part #701), and/or soot on the flame rod (Part #108). • Check if there is leaking from heat exchanger. (Part #401)
Two Times	31	Outlet thermistor failure	<ul style="list-style-type: none"> • Check for connection/breakage of wires and/or debris on thermistor. (Part #407, 408)
	32	Inlet thermistor failure	
Two Times	39	Air –fuel Ratio Rod failure	<ul style="list-style-type: none"> • Check for connection/breakage of wires (Part #709) and/or soot on the AFR rod. (Part #108)

Red LED	Remote	Malfunction description	Diagnosis
Six Times	51	Abnormal Gas Solenoid Valve	<ul style="list-style-type: none"> • Check for connection/breakage of wires (Part #708) and/or burn marks on the computer board (Part #701).
Six Times	55	Abnormal Main Gas Valve	<ul style="list-style-type: none"> • Check for connection/breakage of wires (Part #708) and/or burn marks on the computer board (Part #701).
Four Times	61	Fan Motor Fault	<ul style="list-style-type: none"> • Check for connection/breakage of wires, dust buildup in the fan motor (Part #103) and/or burn marks on the computer board (Part #701). • Check for frozen/corrosion of connectors (Part #103).
One Time	70	Computer board Fault	<ul style="list-style-type: none"> • Check for connection/breakage of wires (Part #714) and/or burn marks on the computer board (Part #701). • Check the power supply of the water heater.
Six Times	72	False Flame Detection	<ul style="list-style-type: none"> • For indoor models, check if condensate drain is installed on the vent collar of the water heater. • Check if there is leaking from heat exchanger (Part #401).
N/A	74	Miscommunication between Water heater and remote controller	<ul style="list-style-type: none"> • Check the model type of the remote controller. • Inspect the connections between the water heater and remote controller. • Check the power supply of the water heater.
Five Times	99	Imperfect combustion	<ul style="list-style-type: none"> • Check the gas type of the water heater. • Inspect the environment around the water heater. Determine how long the unit has been installed. • Check the altitude/elevation of the area of where the water heater installed. • Check if there is any blockage in the intake air and/or exhaust. • If the water heater is installed as a direct-vent system, check whether there is enough distance between the intake air terminal and the exhaust terminal. • Check if there is grease and/or dirt in the burner (Part # 101) and the fan motor (Part # 104), especially if the water heater has been installed in a contaminated area.

COMPONENTS DIAGRAM

Case assembly

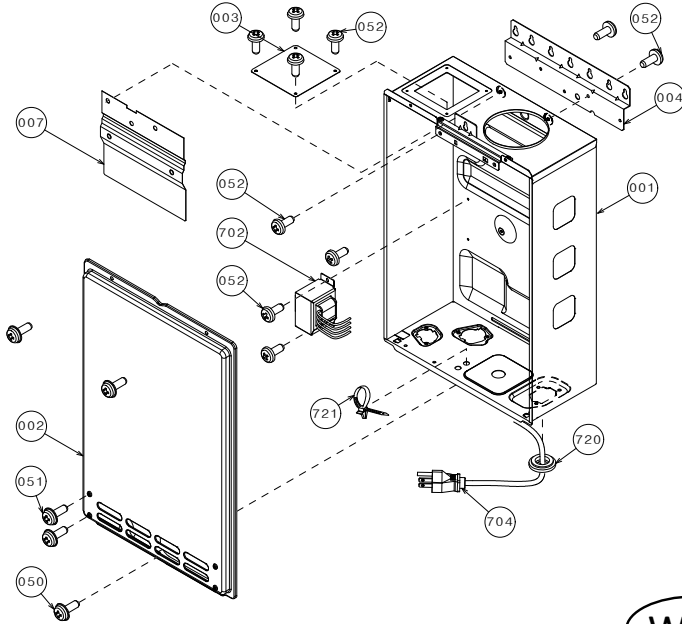

Temperature remote controller

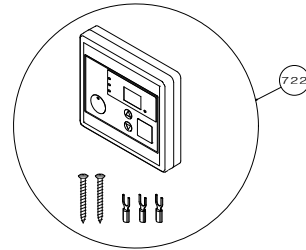

Water way assembly

Computer board Assembly

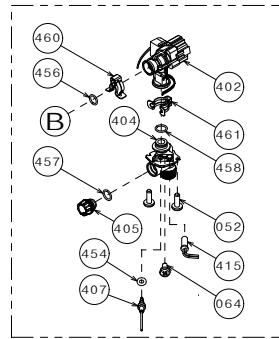
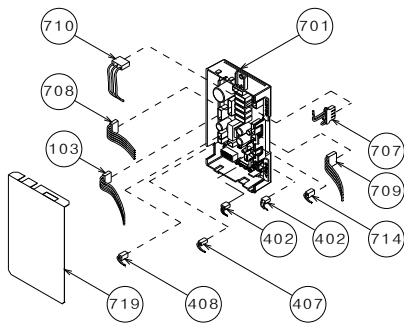

Water inlet section

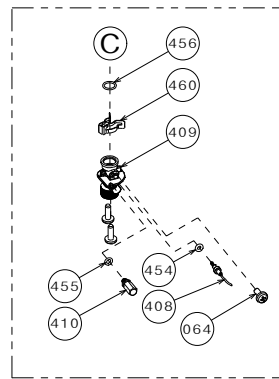
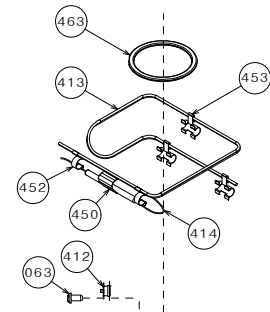

Water outlet section

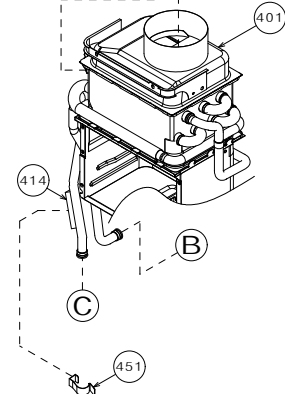

Burner assembly

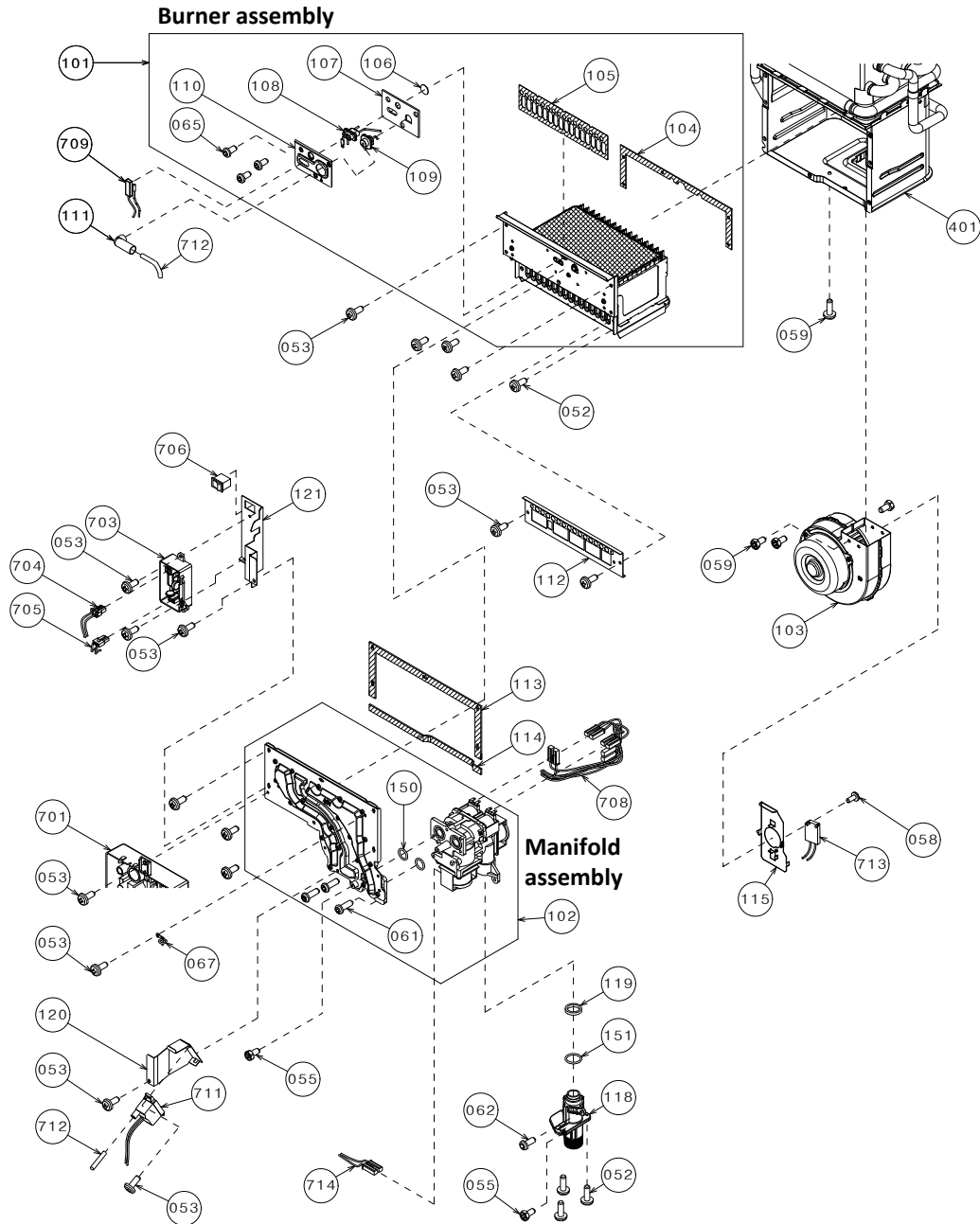

PARTS LIST

Item#	Description	Part#
001	Case assembly	319143-159
002	Front cover	319143-163
003	Air blockage plate	319143-150
004	Bracket	319143-184
005	Junction box	319143-014
006	Junction box inner plate	319143-128
007	Back guard panel	319143-338
050	Screw M4x12 (W/Washer)	319143-025
051	Screw M4x10 (W/Washer)	319143-325
052	Screw M4x10 (Coated)	319143-026
053	Screw M4x10	319143-060
055	Hex head screw M4x8	319143-063
056	Screw M4x10	319143-372
058	Screw M3x10	319143-327
059	Pan screw M4x12 (W/Washer)	319143-061
061	Tap tight screw M4x12 FEZN	319143-201
062	Pan screw M4x10	319143-062
063	Screw M3x6	319143-087
064	Screw M4x6	319143-328
065	Pan screw M4x8	319143-059
066	Nylon clamp	319143-143
067	Wire clamp 60	319143-048
101	Burner assembly	319143-161
102	Manifold with gas valve assembly LP	319143-169
	Manifold with gas valve assembly NA	319143-165
103	Fan motor	319143-347
104	Burner holder gasket	319143-341
105	Burner gasket	319143-031
106	Burner window	319143-033
107	Rod holder gasket	319143-034
108	Flame rod	319143-339
109	Igniter rod	319143-373
110	Rod holder	319143-340
111	Rod cap	319143-038
112	Burner damper	319143-170
113	Manifold gasket A	319143-044
114	Manifold gasket B	319143-045
115	Fan damper	319143-160
118	Gas inlet	319143-050
119	Gas inlet ring	319143-049
120	Igniter plate	319143-051
121	Surge box plate	319143-213
150	O-ring P18 NBR (Black)	319143-350
151	O-ring P20 NBR (Black)	319143-057

Item#	Description	Part#
401	Heat exchanger assembly	319143-162
402	Flow adjustment valve/Flow sensor	319143-167
404	Water inlet	319143-193
405	Inlet drain plug	319143-197
407	Inlet thermistor	319143-214
408	Outlet thermistor	319143-218
409	Water outlet	319143-194
410	Outlet drain plug	319143-199
412	Hi-Limit switch	319143-228
413	Overheat-cut-off fuse	319143-149
414	Heater	319143-200
415	Inlet heater	319143-078
450	Pipe heater fixing plate	319143-088
451	Heater fixing plate 16	319143-125
452	Fuse fixing plate 18	319143-066
453	Fuse fixing plate 14	319143-146
454	O-ring P4 FKM	319143-082
455	O-ring P6 FKM	319143-080
456	O-ring P14 FKM	319143-100
457	O-ring P15 FKM	319143-091
458	O-ring P16 FKM	319143-083
460	Fastener "14-22"	319143-105
461	Fastener "16A"	319143-226
463	Silicon ring	319143-065
701	Computer board	319143-164
702	Transformer	319143-182
703	Surge box	319143-168
704	AC120V wire	319143-427
705	Transformer wire	319143-155
706	AC120V Power ON-OFF switch	319143-141
707	Switch wire	319143-154
708	Gas valve wire	319143-207
709	Flame rod wire	319143-171
710	EH-IG wire	319143-209
711	Igniter	319143-052
712	High voltage igniter cable	319143-039
713	Freeze protection thermostat	319143-185
714	Proportional gas valve wire	319143-220
719	Computer board cover	319143-212
720	Rubber grommet	319143-426
721	Cable strap	319143-425
722	Temperature remote controller	319143-352

OUTPUT TEMPERATURE CHART

Chart is based on properly sizes gas line

Output Temperature vs. GPM (Max. 6.6 GPM) with Various Inlet Water Temperature

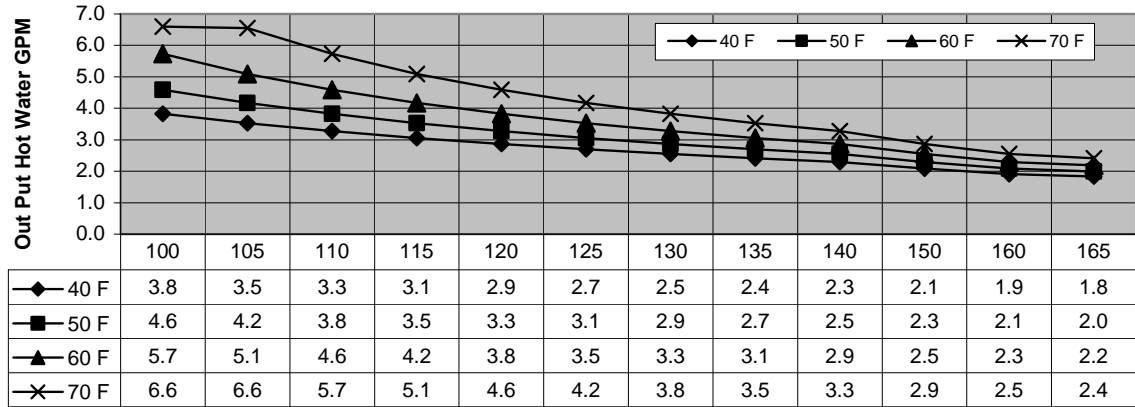

LIMITED WARRANTY

1. General terms of limited warranty:

This limited warranty gives you specific legal rights, and you may also have other rights which vary from State to State. The manufacturer, Hydro-Smart Inc. will honor the warranty to the original retail buyer at the original location only, and it is not transferable. **THIS WARRANTY COVERS ONLY FAILED MECHANICAL AND ELECTRICAL PARTS DUE TO FACTORY DEFECTS UNDER NORMAL USAGE FOR THE PRODUCT'S INTENDED PURPOSES. ONLY DIRECT DAMAGES SHALL BE RECOVERABLE BY A CLAIMANT UNDER THIS LIMITED WARRANTY AND, IN NO EVENT, WHETHER AS A RESULT OF BREACH OF CONTRACT, BREACH OF WARRANTY, TORT LIABILITY (INCLUDING NEGLIGENCE), STRICT LIABILITY, INDEMNITY OR OTHERWISE WILL Hydro-Smart BE LIABLE FOR ANY SPECIAL, INCIDENTAL, OR INDIRECT CONSEQUENTIAL DAMAGES INCLUDING PROPERTY DAMAGE, PERSONAL DAMAGES, LOSS OF USE, OR INCONVENIENCE. SOME STATES DO NOT ALLOW THE EXCLUSION OR LIMITATION OF INCIDENTAL OR CONSEQUENTIAL DAMAGES, SO THE ABOVE LIMITATION MAY NOT APPLY TO YOU.**

2. Parts Warranty

If all of mechanical and/or electrical part fails within two (2) years in normal operation with "Integrator Panel" and proper installation (see instruction from installation manual) from the purchasing date, Hydro-Smart Inc. will furnish a replacement part(s) excluding field labor and shipping.

3. Repair, Replacement or Refund:

The manufacturer, Hydro-Smart Inc. or its authorized Service Representative will, at its sole discretion, repair or replace any failed or defective mechanical or electrical parts, or components thereof, or, if Hydro-Smart or its authorized Service Representative cannot replace said parts, and repair is not commercially practicable, Hydro-Smart or its authorized Service Representative will refund the purchase price. Hydro-Smart or its authorized Service Representative may, at its sole discretion, use new, refurbished or reconditioned parts.

4. Limitation on Duration of Implied Warranties:

ANY IMPLIED WARRANTIES ARISING UNDER STATE LAW, INCLUDING THE IMPLIED WARRANTIES OF FITNESS FOR A PARTICULAR PURPOSE AND MERCHANTABILITY, SHALL IN NO EVENT EXTEND PAST THE EXPIRATION OF ANY WARRANTY PERIOD HEREUNDER. SOME STATES DO NOT ALLOW LIMITATIONS ON HOW LONG AN IMPLIED WARRANTY LASTS, SO THE ABOVE LIMITATION MAY NOT APPLY TO YOU.

5. **THIS WARRANTY WILL NOT COVER THE FOLLOWING:**

- Any Hydro-Smart unit that is not installed by a licensed plumber, gas installer, or contractor.
- Damages due to accidents, abuse, misuse, improper installation, misapplication, or incorrect sizing.
- Damages due to fires, flooding, freezing, electrical surges, or any Acts of God.
- Damages due to unauthorized alterations, attachments, and/or repairs.
- Damages due to a lack of maintenance. (e.g. water treatment system, vent blockage, etc.)
- Any Hydro-Smart unit installed in an improper environment (e.g. corrosive, dusty, chemically contaminated, excessive lint, etc.).
- Freeze damage that occurs without taking proper preventive measures as described in the installation manual.
- Condensate damage due to improperly installed or lack of a condensate trap (drain).
- Any Hydro-Smart unit not installed in compliance with all applicable local & state codes, ordinances, and good trade practices.
- Any Hydro-Smart unit sold to or installed in areas outside of the fifty states (and the District of Columbia) of the United States of America and Canada.
- Any Hydro-Smart unit installed in applications that cause the water heater to activate more than 300 times per day (this averages to an activation every 5 minutes in a 24-hour period).
- Any failures that are not due to defects in materials or workmanship (mechanical and/or electrical parts).
- Damages due to improper installation:
 - Gas: incorrect gas pipe sizing, incorrect gas meter sizing, incorrect gas type, and/or gas pressures that fall outside the product's specified range.
 - Water: incorrect water pipe sizing, water pressures that fall outside the product's specified range, recirculation flow rates that fall outside the product's specified range (air removal), and/or lack of proper methods of air removal in a closed-loop, circulation system (see installation manual for details).
 - Electric: supply power voltages that fall outside the product's specified range.

- Damages due to water quality:
 - Introduction of liquids other than potable water or potable water / glycol mixtures into the product.
 - Introduction of pool water, spa water, or any chemically treated water into the product.
 - Introduction of hard water measuring more than 7 grains per gallon (120 ppm) for single family domestic applications or more than 4 grains per gallon (70 ppm) for all other types of applications into the product.
 - Introduction of untreated or poorly treated well water into the product.
 - Introduction of water with pH levels less than 6.5 and greater than 8.5 into the product.
- Failure of Hydro-Smart due to use other than micro boiler with “Integrator Panel” or if not use with “Integrator Panel”.

