

**NOAH II^(TM) Total Precipitation Gauge
12-inch Capacity
Manually Serviced**



Technical Manual



INSTRUMENT

SYSTEMS INC.

**1317 Webster Avenue
Fort Collins, Colorado 80524
970 484-9393**

Technical Manual

Table of Contents

Chapter	Title	Page
1	System Description and Specifications	1-1
	1.1 Description	1-1
	1.2 Specifications	1-3
2	Installation	2-1
	2.1 Parts List	2-1
	2.2 Installation	2-1
3	Startup Procedure	3-1
	3.1 Startup	3-1
4	Theory of Operation	4-1
	4.1 Overview	4-1
	4.2 Measurement	4-1
	4.3 Temperature and Noise Filters	4-1
	4.4 Emulated Tipping Bucket Output	4-2
5	Operation and Service	5-1
	5.1 Normal Operation	5-1
	5.2 Routine Servicing	5-1
	5.3 Retrieving Data From the Optional Memory Data Logger	5-1
	5.4 Draining Accumulated Precipitation	5-2
	5.5 Removing Debris From Collection Chamber	5-2
	5.6 Replenishing Antifreeze and Evaporation-suppressant Oil	5-3
	5.7 Battery	5-3
6	Operational Testing, Maintenance, and Troubleshooting	6-1
	6.1 Operational Testing	6-1
	6.2 Maintenance	6-3
	6.3 Troubleshooting	6-4
7	Calibration	7-1
	7.1 Maintenance Characteristics of the Gauge	7-1
	7.2 Equipment and Materials Needed	7-1
	7.3 The Calibration Procedure	7-2
	7.4 The Validation Testing Procedure	7-7
8	Accessories	8-1
	8.1 Windscreens	8-1
	8.2 Antifreeze Solution	8-1
	8.3 Solar Power System	8-1
Appendix A	P7GACOMM Functions	A-1
	Windscreen Assembly	A-9

SECTION 1

DESCRIPTION AND SPECIFICATIONS

1.1 Description - (NOAH II^(TM) Manually Serviced 12-inch Capacity)

The ETI NOAH II^(TM) Total Precipitation Gauge provides accurate measurement of precipitation in the form of either rain or snow over the full range of temperatures and environmental conditions. The NOAH II features:

- *Capacity* - Can collect up to 12 inches of precipitation before it requires manual draining and resetting.
- *Low Maintenance* - Can operate unattended for long periods of time, depending on the amount of precipitation collected. Optional solar power system includes solar panels, regulator and battery to provide a continuous source of power.
- *Weighing-type transducer* - Precise measuring components deliver accuracies to + or - 0.01 inches.

The major components of the NOAH II include:

- (1) A chamber to collect precipitation,
- (2) A Weight Measurement Assembly (WMA) electronics module which measure and outputs digital pulses of the amount of precipitation collected,

Optional:

- (3) A solar panel, battery and regulator supplying 12 VDC power.
- (4) Windscreen

1.1.1 The Collection Chamber. This cylindrical assembly is 34 inches tall with a false bottom located 20 inches below the 12-inch diameter inlet orifice.

Precipitation in the form of either rain or snow is collected in the chamber and mixed with a charge of antifreeze to keep the contents from freezing. A thin film of evaporation-suppressant oil manually placed in the gauge during regular servicing retards evaporation of the solution.

The collection chamber has 12 inches capacity. The total amount of precipitation catch is dependent on the amount of antifreeze required for expected temperatures. A manual drain valve allows for draining the mixture of antifreeze and precipitation.

1.1.2 The Weight Measurement Assembly. The WMA is mounted below the false bottom of the collection chamber and is housed in an integral aluminum enclosure with a lockable door. Its major components include a highly sensitive load transducer, a Mylar diaphragm, and precision 16-bit digital electronics.

A protected inlet hole located in the center of the collection chamber's false bottom allows the weight of the solution in the chamber to be transferred to the Mylar diaphragm. The diaphragm is supported by the load plate such that the load transducer is weighing only the column of liquid directly above the load plate. Precision electronics calculate the amount of precipitation collected.

The gauge electronics measure the load transducer output and converts this measurement to hundredths of inches of precipitation. As the accumulated precipitation increases, the gauge electronics produce a single pulse for each 0.01 inches of increase.

1.1.3 Mounting. The bottom of the standpipe has three bolt holes for mounting to a customer-provided pad (or platform if the gauge requires elevating above the expected snow depth).

1.1.4 Windscreen. The ETI gauge can be fitted with an optional windscreen assembly designed for the gauge to improve collection efficiencies during light to moderately windy conditions.

1.1.5 Antifreeze. The use of ETI's ethanol/glycerine antifreeze and evaporation-suppressant oil (both environmentally friendly), together with temperature-compensation electronics, eliminate the need to employ heating.

1.1.6 Power. The gauge requires a supply of 12 volts DC and will drain an average of 18 milliamperes. The battery is supplied by the customer and should be sized to accommodate the power required between projected service intervals.

ETI recommends a charging mechanism to ensure continuous operation and to avoid frequent replacement of the battery. If the charging mechanism is powered by utility a/c, it should be protected by a high quality surge protector.

ETI can supply an optional solar power system, which includes a solar panel, regulator, and an 18 amp-hour battery. This system will provide continuous unattended operation with very little required maintenance.

1.2 Specifications:

Sensor type:	Electronic weighing-type gauge
Capacity:	Up to 12 inches of precipitation
Accuracy:	+ or - 0.01 inches (in calm or light wind conditions)
Sensitivity:	0.01 inches
Resolution:	0.01 inches
Orifice:	12 inches
Operating temperature range:	-30° to +50° C (-40° C optional)
Power Requirements:	12 VDC, 18 ma average current
Weight:	27 pounds
Size:	12 inches diameter x 34 inches height

SECTION 2

INSTALLATION

2.1 Parts List

- 1) Collection chamber with key-lock door providing access to a built-in enclosure housing the electronics, drain valve, and battery.
- 2) Manual drain valve and extension hose

2.2 Installation

The NOAH II is a highly sensitive instrument, and its measurement accuracies are readily affected by vibrations. Therefore, it is critical that the structural assembly be mounted on a substantial, rigid pad or platform. The gauge incorporates a base flange with three bolt holes to facilitate the mounting.

The gauge requires a 12 volt DC battery with sufficient amp-hour capacity to provide the power required between expected service intervals. A 24 amp-hour battery should provide power for approximately 50 days, depending on the temperature.

The gauge has an integral enclosure to house the WMA, battery and manual drain valve .

The manual gauge cable has four wires with bare ends extending from it. The four wires are to be connected as follows:

RED wire	Connector Pin 1	Battery positive (+)
BLACK wire	Connector Pin 3	Battery negative (-)
GREEN wire	Connector Pin 6	Datalogger common
BROWN wire	Connector Pin 2	Datalogger pulse input channel

If the cable has to be run more than 30 feet from the WMA, use shielded cable and ground to prevent interference noises.

Note: To avoid damage to load transducer and electronics... It is *very important* that the gauge housing be connected to the same ground as the data logger. Keep cable runs as short as possible and keep the gauge housing at the same potential as the data system ground. If the gauge is to be located in an open area where lightning is likely to occur, it would be advisable to install a lightning rod and ground to provide a measure of protection for the system.

An internal grounding lug has been provided with the gauge.

When installation of the gauge has been completed, proceed to the next Section of this manual, *Startup*.

SECTION 3

STARTUP PROCEDURE

3.1 Startup

The start up procedure occurs after installation is complete and all cables are correctly connected. **The battery must be disconnected at this point.** If power were to be applied, the gauge would go into a fault mode because of lack of antifreeze or water in the chamber.

Initial setup requires the following equipment and supplies:

- Antifreeze sufficient for charging the gauge to withstand expected lowest temperatures
- A graduated cylinder that will hold 180 milliliters

A successful startup depends on carefully following the step-by-step instructions described below.

1. Open the key-lock door that provides access to the WMA and collection chamber drain valve.
2. Close the manual drain valve.

Note: To avoid damage to the sensitive load transducer, do not pour antifreeze directly onto the WMA sensor inlet.

3. Add antifreeze to the collection chamber according to the following expected lowest temperatures:

The Table below shows the amount of antifreeze necessary to keep the solution from turning to slush at the temperatures on the left. (Assuming a 12-inch solution of antifreeze and water.)

<u>Lowest Expected Temperature</u>	<u>Antifreeze Necessary</u>
-45C	7.5 inches
-35C	6.0 inches
-25C	4.8 inches
-15C	3.6 inches
- 5C	2.4 inches

- Even if expected temperatures are above freezing, you should place one inch of antifreeze in the chamber to protect the WMA.

4. Pour in a thin layer of evaporation-suppressant oil completely covering the liquid surface to retard evaporation of antifreeze and collected precipitation. **Without this evaporation oil, the antifreeze will completely evaporate out of the catch chamber within a short time.**

5. Apply power to the gauge by connecting battery leads—red lead to positive, black lead to negative.

SECTION 4

THEORY OF OPERATION

4.1 Overview

A block diagram of the NOAH II (™) Total Precipitation Gauge weight measurement assembly (WMA) electronics is shown in Figure 4.1. All functions are controlled by a single chip microcomputer (MCU) under the direction of a gauge management program, which is resident within the MCU on-chip EPROM. A second on-board EPROM stores all calibration constants, temperature coefficients, and timing sequence.

There are three basic functions performed by the gauge electronics, which are described in detail in the following subsections. These are:

- Measurement of the weight of liquid in the gauge
- Temperature and noise compensation digital filters
- Providing output pulses that emulate a tipping bucket gauge

4.2 Measurement

A precision full bridge load transducer provides an electrical output directly proportional to the weight of the liquid in the gauge. The low-level output of the load transducer is converted to a high-level signal by a narrow bandwidth, chopper stabilized, precision signal conditioning module with a low temperature coefficient. The signal conditioning module output is converted to a digital value using a 16-bit analog-to-digital (A/D) converter that provides a resolution capability of one part in 65,536. Approximately 20 raw counts are equal to 0.01 inch.

The load transducer excitation voltage is provided by the signal conditioning module. To minimize power consumption, the MCU turns on the load transducer excitation for 2.5 seconds every ten seconds (a .5 second warmup and a two second sample period). During the sample interval, the A/D converter is sampled nearly 3,000 times by the MCU. The 3,000 samples are digitally averaged to eliminate electronic noise.

4.3 Temperature and Noise Filters

A software digital filter algorithm processes the raw counts over a 90 second, nine sample interval to eliminate or reduce wind-induced errors. The first precipitation event is delayed by 90 seconds to allow the digital filter to process the raw data.

A temperature sensor installed on the gauge electronics circuit board provides an analog output proportional to the temperature of the electronics and the adjacent load transducer. This output is converted to a binary value by an 8-bit A/D converter. The MCU uses the temperature value to correct the load transducer raw data measurements for temperature

effects. A temperature tracking software algorithm is utilized to eliminate errors due to temperature changes. The raw data is temperature compensated and corrected every degrees.

To maintain a .01 inch threshold that will eliminate or minimize false precipitation events, the first .01 to .02 inches are delayed by fifteen minutes (programmable). The precipitation event has to remain valid for the delay period—then the WMA will output the pulse. If the precipitation event does not remain valid for the programmed period, the delay timer is reset to zero. Precipitation events greater than .02 inches will be output at the end of the 90 second digital filter process.

4.4 Emulated Tipping Bucket Output

Nearly all data loggers are configured to accept switch closures associated with tipping bucket-type gauges. The NOAH II WMA has an MOSFET open collector output which utilizing the customer furnished data loggers +5 VDC pull-up on the input to pulse counting channel.

Load transducer measurements are made every ten seconds and processed by the various algorithms to reduce errors caused by fluctuations due to wind, vibrations, etc. The temperature is measured once per minute, and temperature corrections are calculated every degrees and applied to the transducer measurement. The corrected load value is calculated and compared with the corrected reference value stored when the last tipping bucket output pulse was generated. If the difference exceeds a threshold corresponding to .01 inch in accumulated precipitation, a flag is set and the reference value is changed to the current corrected load transducer value.

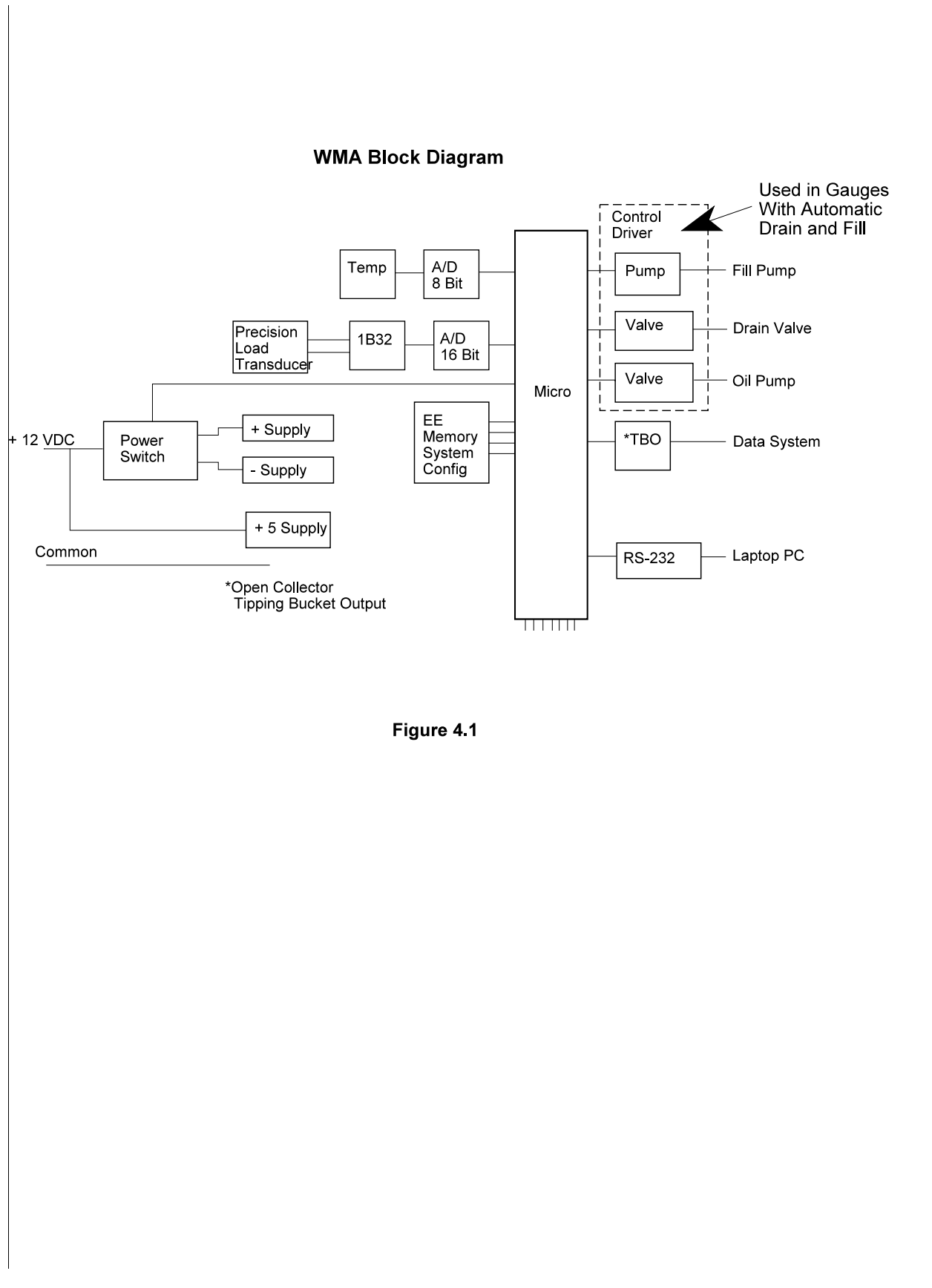

Figure 4.1

The drawing below depicts the electrical output of the WMA to the customer's datalogger.

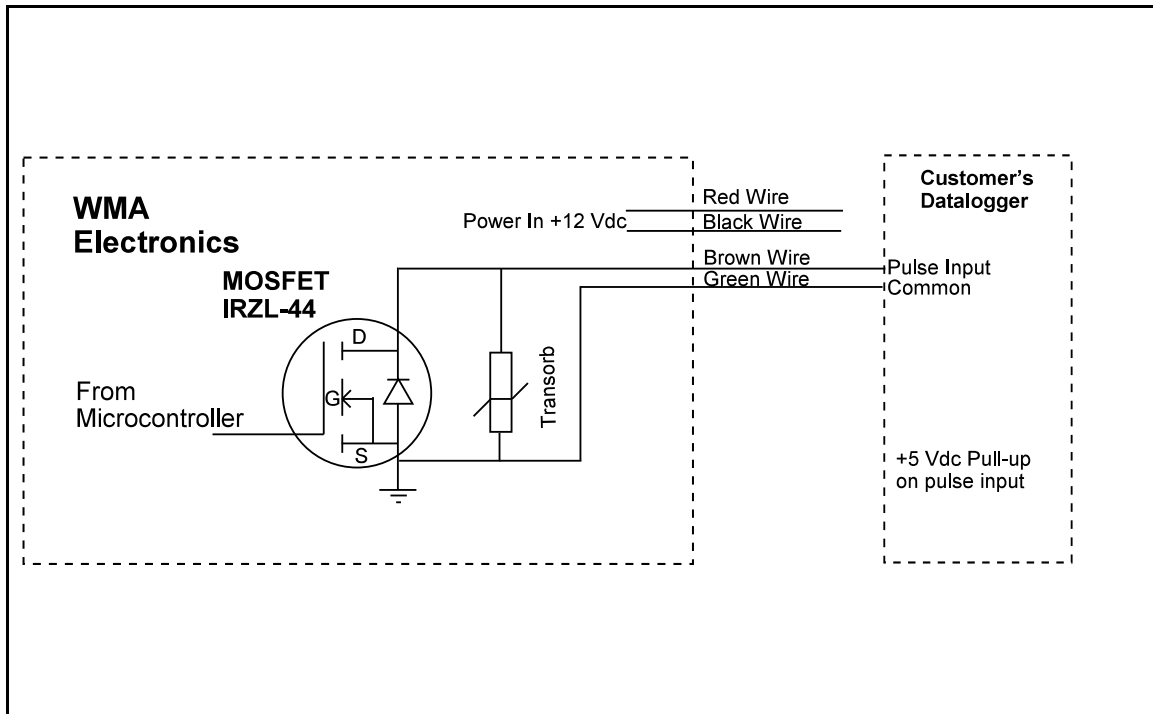

Figure 4.2

SECTION 5

OPERATION AND SERVICE

5.1 Normal Operation

As precipitation accumulates, the added weight of water is measured by the Weight Measurement Assembly (WMA). The WMA produces a simulated Tipping Bucket Output (TBO) signal. The pulses are sent to the customer's data collection data logger each time 0.01 inches of precipitation is accumulated.

The measurement process includes automatic compensation, through software, for the effect of temperature of the gauge on the output of the load sensor. Temperature-induced errors are further minimized because the gauge measures differential incremental increases in precipitation and is not simply recording the total weight of the entire gauge contents.

5.2 Routine Servicing

Routine servicing of the NOAH II manual gauge normally entails:

- Draining the accumulated precipitation
- Removing debris
- Replenishing the antifreeze and evaporation-suppressant oil
- Inspecting the power supply system and battery and replacing it if necessary

5.4 Draining Accumulated Precipitation

Open the door that provides access to the drain valve (and battery and WMA). Open the drain valve and drain the gauge contents into a suitable container. Close the drain valve.

The NOAH II ethanol antifreeze is not classified as a hazardous material (as is ethylene glycol and methanol). However, it should be carried away from the site and diluted substantially with water before disposal.

5.5 Removing Debris from Collection Chamber

The gauge will tend to collect debris, including leaves, pine needles, dirt, and insects. During routine servicing, look into the chamber after draining and use a cloth to remove debris and wipe the insides clean. If it is extremely dirty, it should be thoroughly cleaned as described in Section 6.2.

5.6 Replenishing Antifreeze and Evaporation-suppressant Oil

Refill with the proper level of antifreeze for expected lowest temperatures according to the following:

- Refer to table in Section 3.2
- Even if expected temperatures are above freezing, you should place one inch of antifreeze in the chamber to protect the WMA.

Add a thin film of evaporation-suppressant oil to retard evaporation.

5.7 Battery

Check the battery voltage. If there is no external charging capability, exchange the battery if necessary.

SECTION 6

MAINTENANCE AND TROUBLESHOOTING

6.1 Operational Testing

An operational test of the NOAH II^(TM) Total Precipitation Gauge may be performed to validate that the measuring and recording components are operating satisfactorily.

This test involves the manual addition of measured amounts of water and observing the amount recorded by the gauge. This requires that the gauge be connected to a personal computer (PC) that has the ETI program P7GACOMM installed.

Equipment and Materials Needed:

- Laptop portable computer (PC) with ETI program P7GACOMM
- Nine-pin RS-232 connector cable to connect the PC's serial port to the WMA electronics
- Graduated cylinder that holds at least 100 milliliters
- Antifreeze sufficient to recharge the gauge to accommodate expected lowest temperatures

This test procedure is applicable to both new and existing installations.

1. Open the key-lock door that provides access to the WMA and collection chamber drain valve.
2. This test involves adding measured quantities of water to the gauge and observing the amount reported by the gauge's measuring components. Notice where the current level of antifreeze/precipitation solution presently is. If it is near the ten inch level of collection chamber, you may want to drain the chamber and recharge with the proper amount of antifreeze and add evaporation-suppressant oil before proceeding.
3. Connect the RS-232 cable from the PC's serial port to the 9-pin connector on the WMA.
4. Run the program P7GACOMM. A menu screen will appear on the PC that lists a number of procedures for analyzing and reprogramming the WMA. To determine how the gauge's output relates to the actual amount of water placed in the collection chamber, run the procedure **"Multiple Unit Data Logging and Testing"** by pressing function key **F7**.

5. The program then asks for your response to several questions that are necessary for the initial setup. The illustration below shows the program's questions and your suggested entries (underlined).

(computer prompt)

(your response)

ENTER NUMBER OF UNIT ACTIVATED : 1

ENTER NUMBER OF UNIT ACTIVATED : 0

FILE TO WRITE TO : WMATEST

(You may use whatever name you please. If the file does not exist, it will create it. If it does exist, it will ask if you want to overwrite it.)

SECONDS FOR TAKING MEASUREMENT : 3

SECONDS BETWEEN MEASUREMENTS : 10

The PC will then display a screen similar to the following:

MULTIPLE UNIT DATA LOGGING AND TESTING

9:12:50

11:32

9/12/00

Cnt 5423	(Raw level counts from transducer)
T1d 290.00	(Temperature in degrees Kelvin of load cell)
T1b 286.00	(Temperature in degrees Kelvin of electronics)
In. 2.034	(Inches of solution as calculated from raw counts)

6. Note and record the amount of water in inches reported by the program. This is the base reference level from which additional increments of water will be measured.
7. Pour in 90 milliliters of water; wait until the readings have stabilized (two-plus minutes) and record the inches measured. The gauge is an incremental measuring device; therefore the present reading should be exactly 0.05 inch more than the previous reading.
8. If you want, repeat the process a few more times to ascertain how the gauge is functioning over a wider range. When you have completed the test, press function key F10 to exit the procedure.
9. If the gauge is performing within acceptable accuracies, disconnect the PC and close and lock the access door.
10. Make sure the gauge has the proper level of antifreeze and evaporation-suppressant oil.

The NOAH II is now ready to resume unattended measurement of rain and snow precipitation.

6.2 Maintenance

6.2.1 Cleaning Collection Chamber: The gauge will tend to collect all manner of debris, including leaves, pine needles, dirt, and insects. Dense accumulation in the gauge may eventually interfere with proper operation. The catch chamber should, therefore, be cleaned periodically to remove the accumulation of sediment from the bottom of the collection chamber.

To clean the collection chamber, disconnect the gauge from the customer's pad or platform. Disconnect and remove the battery and gauge hose. Then invert the collection chamber to remove any debris, including that which may have entered the WMA. The gauge may be cleaned with a mild soap and then flushed carefully and completely with water.

*** * * CAUTION * * ***

Do not allow high pressure hose water to enter the weighing mechanism orifice and do not attempt to poke into the orifice. You will damage the sensitive load transducer in the weighing mechanism.

After servicing, be careful to remove all the water from the weight measurement assembly to prevent freezing. After cleaning the collection chamber, reinstall it on its mounting pad or platform. Restart the system by connecting the battery and listening for audible "beeps" indicating that the WMA has been reset. Then reinitialize the system according to the procedures in Section 3, Startup.

6.2.2 Battery: The battery voltage can be maintained by a solar power system or other charging unit. The quiescent current consumed by the system is approximately 18 ma, which supports monitoring and interpreting the load sensor. Check condition of the battery and clean its terminals; clean the solar panel and its terminals.

6.2.3 Test: After servicing, the gauge may be tested by adding a small amount of water to the collection chamber (refer to the Operational Test at the beginning of this section).

6.3 Troubleshooting

If the gauge is not collecting or reporting data, perform the following:

1. Inspect the battery and its connections. The most common failure is a fault in the power source. Disconnect, clean and reconnect battery leads (and other connections if the gauge has a solar panel or other charging device). Listen for the audible beeps indicating that the WMA electronics are resetting. If the beeps are heard, the WMA is working.
2. Make sure the gauge has the proper level of antifreeze. Otherwise, when power is applied the WMA will go into a fault mode (indicating a level below the evaporation lower limit) and have to be reset.
3. Look into the collection chamber.

Is there enough evaporation suppression oil to cover the liquid surface to prevent evaporation of the antifreeze?

Is the chamber full of slush (at cold temperatures)?

Has antifreeze evaporated due to lack of evaporation-suppressant oil?

SECTION 7

CALIBRATION PROCEDURES

7.1 Measurement Characteristics of the Gauge

The NOAH II collection chamber will collect and measure 12 inches of precipitation before a manual drain is necessary. Over the 12-inch measurement span, the output produced by the transducer has a slight non-linearity that is characteristic of this technology. Even though this departure from an absolutely straight-line correspondence of the weight of the water to transducer output is very slight, the electronics in the gauge will compensate for it.

To account for the non-linearity, the gauge employs three straight-line approximations. The first line applies for those measurements from 1 to 4 inches, the second from 4 to 7 inches, and the third from 7 to 11 inches. Periodic validation tests (described in the NOAH II Setup and Checkout Manual) ensure that the gauge is reporting properly over each of the measurement ranges.

If the validation test shows that the gauge does not report precipitation within the required accuracy, then the calibration process should be done. The calibration will calculate new parameters for the three straight lines. That will bring the gauge's reporting back to proper operation.

7.2 Equipment and Materials Needed

- Laptop portable computer (PC) with ETI program P7GACOMM and MicroSoft EXCEL spreadsheet (or a spreadsheet that can import EXCEL spreadsheets)
- Nine-pin RS-232 connector cable to connect the PC's serial port to the WMA electronics
- Graduated cylinder that holds at least 1800 milliliters
- A syringe, squeeze bulb, or eyedropper for transferring small quantities of water
- A 12-volt battery

7.3 The Calibration Procedure

The calibration process involves placing known quantities of water in the collection chamber and measuring the WMA's electrical output signals. The proper relationship of the WMA output to the quantity of water is calculated using the steps below. You will then enter the revised parameters which will be reprogrammed into the WMA's electronics.

The following describes the procedure for calibrating the WMA in the laboratory:

1. Place the collection chamber assembly, which includes the WMA and associated electronics, on a stable bench. A container that can hold the full eleven inches of solution should be placed under the assembly so that the drain tube can drain the contents directly into it. The battery also should be on the bench to be in reach of the WMA power leads.
2. Open the key-lock door that provides access to the WMA and collection chamber drain valve.
3. Fill the collection chamber with water, about 11 inches. Remove any air that may be trapped in the WMA by tapping on the outside or gently moving the collection chamber until there is no evidence of air bubbles. Wait five minutes to let the components reach an equilibrium. Do **not** hurry this process. Any air in the WMA opening **will adversely affect** the calibration.
4. Connect the RS-232 cable from the PC's serial port to the 9-pin connector on the WMA. Connect the WMA power leads to the battery—red lead to positive and black lead to negative.
5. Open the drain valve and allow the water in the chamber to drain until the the chamber is empty. About one-quarter inch of water will remain. Close the drain valve.
6. Add water until the level is TWO INCHES above the WMA inlet opening. This will establish a base level from which to begin the calibration.
7. Run the program P7GACOMM. A menu screen will appear on the PC that lists a number of procedures for analyzing and reprogramming the WMA. To determine how the gauge's output relates to the actual amount of water placed in the collection chamber, run the procedure "**Multiple Unit Data Logging and Testing**" by pressing function key **F7**.

8. The program then asks for your response to several questions that are necessary for the initial setup. The illustration below shows the program's questions and your suggested entries (underlined).

(computer prompt)

(your response)

ENTER NUMBER OF UNIT ACTIVATED : 1
ENTER NUMBER OF UNIT ACTIVATED : 0
FILE TO WRITE TO : WMATEST

(You may use whatever name you please. If the file does not exist, it will create it. If it does exist, it will ask if you want to overwrite it.)

SECONDS FOR TAKING MEASUREMENT : 3
SECONDS BETWEEN MEASUREMENTS : 10

The PC will then display a screen similar to the following:

MULTIPLE UNIT DATA LOGGING AND TESTING
9:12:50 11:32 9/12/00

Cnt 5423	(Raw level counts from transducer)
T1d 290.00	(Temperature in degrees Kelvin of load cell)
T1b 286.00	(Temperature in degrees Kelvin of electronics)
In. 2.034	(Inches of solution as calculated from raw counts)

9. Record the raw level counts of the transducer. This will be the base level from which the calibration begins.
10. Pour in precisely 1800 milliliters of water, which equals one inch. Wait until the counts have stabilized and then record the raw counts. Try to be as exact as possible when measuring the water. Even a small variation can affect the calibration. Stabilization will take three to four minutes.
11. Repeat the process until eight 1800 milliliter units of water (above the two-inch base level) have been poured into the collection chamber and the counts measured for each increment. This will have brought the level of water up 10 inches—just below the orifice in the overflow pipe.
12. Press function key **F10** to return to the main menu. Press **F10** again to exit P7GACOMM.
13. The data collected from the above procedure is entered now into a spreadsheet program (MicroSoft EXCEL). The spreadsheet is used to calculate parameters for the three straight-line equations that translate WMA output raw counts into inches. First, run EXCEL and open the worksheet snxxx.XLS (where xxx is the WMA's serial number, on the diskette provided by ETI).

14. Near the top of the worksheet (sample shown below) there is a column headed "Raw Counts" (shaded). Enter the nine values starting at the two inch level (base level plus the eight additional measurements) directly under the heading and to the right of "x inch Reading."

As you enter the raw counts, the worksheet examines the values and checks to see if they are reasonable. If any appear out of acceptable range, the diagnostic "ERROR" appears to the right of your entry warning you that the reading may be in error. (The "ERROR" message may appear as you enter your readings if there is data left in the worksheet from a previous calculation. If so, go ahead and continue entering data. When you have completed, all the "ERROR" messages should have cleared. If some still appear, you do have a questionable entry and the values should be rechecked.)

EXCEL Worksheet (Sample)

NOAH II Calibration Worksheet

S/N = 099

11/3/00

Customer Name

READINGS	RAW COUNTS	CALCULATED VALUES		
(Calculated Value)	7107		a =	7112
(Calculated Value)	10507	3400	b =	369
Base - 2 inches	13788	3281	c =	29998
3 inch reading	16950	3162	d =	5647
4 inch reading	19993	3043	e =	347
5 inch reading	22974	2981	f =	20022
6 inch reading	25892	2918	g =	4187
7 inch reading	25624	2843	h =	315
8 inch reading	31522	2787		
9 inch reading	34269	2747		
10 inch reading	36951	2682		

15. After entering the nine values, the spreadsheet will calculate the values needed to complete the calibration. The results are then displayed in cells to the right of the raw counts column (another shaded area). These are the values that are required in the P7GACOMM program for recalibrating the WMA. Write down these values for a, b, c, d, f, g, and h. Exit the EXCEL program.

16. Run the program P7GACOMM. At the main menu, press function key F6 to access the procedure "Set All Values in EEPROM." A screen, shown below, will display that lists a number of parameters that must be reprogrammed into the WMA's EEPROM.

The bold face **a, b, c, d, e, f, g** and **h** in the shaded portion below are where you will enter the values from the spreadsheet.

The cursor is initially at the "a" entry. Type in the new value obtained from the spreadsheet and press ENTER. Then continue to the "b" entry, and on through "h". In the shaded area, the "1000" to the right of "b" can also be changed. Make sure it remains as "1000." (The next entry requires a "P" for positive temperature tracking. After entering "P", the cursor will jump to the next entry without pressing "ENTER.")

```

Set All Current Data in Detector
      14:14:23                10/24/01

Calibration Parameters
(CNTS - a ) * ( b / 1000) = inches / .001 FOR CNTS > c
(CNTS - d ) * ( e / 1000) = inches / .001 FOR CNTS > f
(CNTS - g ) * ( h / 1000) = inches / .001
Positive OR Negative Temperature Tracking (P/N) P
DRAIN When Depth In Inches Shown Is Reached

      Above K      Half Charge   Full Charge
      275.00      11.00         11.00
      265.00      8.00          11.00
      255.00      5.00          9.00
      3.75        6.75
Antifreeze Depth  1.750         3.250
0.500 Absolute Minimum Depth
0.010 Inches per Bucket Tip
0.00 Counts/Degree Temperature Coefficient (use value supplied with WMA)
15 Minutes Delay Before Initial Precip Reported
45 Minutes No Precip To Reset timer
0.5 Sec Power UP  2.0 Sec Sample Time For A/D
1 Counts Step If More Than 5 Counts Change For 9 Loops
1.00 Degrees C change Resets Reference Level 1 Bucket
Reset Reference If Depth 0.03 inches Low for 254 Minutes
    
```

17. When you have completed entering the new values for "a" through "h" and the entry requiring "P," continue pressing ENTER (and checking to make sure the values are the same as those shown above).

(Standard Unit)

```

STORE LEVELS TO RAM?      N
IS RAM PRESENT IN UNIT?  N
SERIAL OUTPUT EACH READ? N
    
```

18. The new parameters will then be loaded into the WMA's internal programming. This completes the calibration procedure. The PC then displays "**Press any key .**"
19. Press the space bar (or any other key) and the main menu of P7GACOMM will appear. Now press function key F5 and the new parameters you have programmed into the WMA will be displayed. If you made a data entry error, press function key F6 again, and step through each of the variables by pressing "ENTER," (except for the "P"—it still requires a "P" entry rather than an "ENTER"), and change any entries that might be in error.
20. The calibration and preliminary verification is now complete. If you desire, you can run a full validation test as described in Section 7.4.

7.4 The Validation Testing Procedure

Validation testing involves placing an accurately measured quantity of water into the gauge's collection chamber and observing the amount recorded by the gauge. If an unacceptable discrepancy exists, the gauge must be recalibrated as described previously. The steps below assume you are continuing from Step 19 in the Calibration Procedure.

1. Add water until the level is about two inches above the WMA inlet opening. With the P7GACOMM program running under F7, "Multiple Unit Data Logging and Testing," note and record the amount of water in inches reported by the program. This is the base reference level from which additional increments of water will be measured.
2. Pour in an additional 1800 milliliters of water; wait until the readings have stabilized and record the inches measured. The gauge is an incremental measuring device; therefore the present reading should be exactly one inch more than the previous reading.
3. Repeat the process until eight additional one-inch quantities (above base level) have been poured in and recorded. You will have measured the gauge over most of its range. Press function key F10 to exit the procedure.
4. If the gauge is not operating satisfactorily, perform a new calibration as described previously. If the gauge is performing within acceptable accuracies, disconnect the PC and battery, open the drain valve, and allow the water to drain (about one-quarter of an inch remains in the collection chamber). Close the drain valve; then close and lock the WMA access door. Turn the unit upside down and allow any remaining water to drain out.
5. The NOAH II is now ready to return to the field for setup and to continue unattended measurement of rain and snow precipitation.

SECTION 8

ACCESSORIES

8.1 Wind Screen

GE Lexan^(TM)

Diameter: 48 inches

Height: 16 inches

Mounting: Mounted as above. Consisting of three curved aluminum rods each with 14 baffles made of GE Lexan^(TM). GE Lexan^(TM) is used for skylights, covered walkways, canopies, sound barriers and other applications which are exposed to severe weather conditions such as wind, hail and heavy snow.

8.2 Antifreeze Solution

ETI blends a NOAH II^(TM) solution containing denatured ethanol and glycerol. Unlike glycol/methanol antifreeze solutions (glycometh), none of the ingredients are on the EPA list of hazardous materials. Gauge waste can be safely handled and readily disposed of through conventional disposal techniques.

We recommend use of ETI's NOAH II^(TM) antifreeze solution with the NOAH II^(TM) Total Precipitation Gauge. An evaporation suppressant oil is supplied with each case of antifreeze solution.

8.3 Solar Power System

ETI can provide a solar power system that consists of a solar panel, regulator, and 12-volt, 12 amp-hour battery to provide continuous unattended operation.

Appendix A

P7GACOMM Functions

1. Description:

P7GACOMM is ETI's DOS-based program for programming, monitoring, and extracting data from the Weight Measurement Assembly (WMA). The normal operational setup includes a 9-pin RS-232 cable connecting a laptop computer's serial I/O port to the serial receptacle on the WMA.

Two files (available from ETI and supplied on the diskette shipped with the WMA) must be loaded onto the laptop computer to provide the necessary interface to the NOAH II's data system. These are:

P7GAMENU.TXT
P7GACOMM.EXE

To execute the program, connect the cable from the laptop to the WMA and type:

P7GACOMM

The PC will then display the following main menu:

```
ETI Precipitation Gauge Interface
 14:15:13  10/15/00

F1  Get ROM checksum, Version, Etc.
F2  Test External RAM
F3  Setup External RAM for Logging Data
F4  Download External RAM to PC File
F5  Read EEPROM Contents
F6  Set All Values in EEPROM
F7  Multiple Unit Logging and Testing
F8  Read RAM Card in Solid State Drive
F10 Exit to DOS
```

To execute the various functions of P7GACOMM, press the appropriate function key as described above.

The sections that follow describe the P7GACOMM functions in detail.

2. P7GACOMM Functions:

2.1 Press Function Key F1 - Get ROM Checksum, Version, Etc.

Computer Response:

```
Software Version 6  
ROM Checksum = 03 HEX  
(c) Sage Engineering, 1999  
PG2GAGE 6.40 Last Update 09/05/99
```

Press Any Key

2.2 **NOTE: DO NOT ATTEMPT TO USE FUNCTIONS F2, F3, F4, AND F8. THEY ARE NO LONGER VALID ON THE NOAH II WMA**

2.3 Press Function Key F5 - Read EEPROM Contents

This function provides a display of all values currently programmed into the WMA. Executing this function will display the calibration information programmed into the unit prior to being shipped. A sample display of EEPROM contents is shown below.

Read Of All Current Data In Detector

```
Calibration Parameters
(CNTS - 7112 ) * ( 369 / 1000) = inches / .001 FOR CNTS>29998
(CNTS - 5647 ) * ( 347 / 1000) = inches / .001 FOR CNTS>20022
(CNTS - 4187 ) * ( 315 / 1000) = inches / .001
Positive OR Negative Temperature Tracking (P/N) N
DRAIN When Depth In Inches Shown Is Reached
  Above K      Half Charge      Full Charge
  275.00      11.00             11.00
  265.00      9.00             11.00
  255.00      5.75             9.00
                   3.75             6.75
Antifreeze Depth  1.750             3.250
  0.500 Absolute Minimum Depth
  0.010 Inches per Bucket Tip
-4.90 Counts/Degree Temperature Coefficient
  15 Minutes Delay Before Initial Precip Reported
  45 Minutes No Precip To Reset timer
  0.5 Sec Power UP  2.0 Sec Sample Time For A/D
  1 Counts Step If More Than 5 Counts Change For 9 Loops
  1.00 Degrees C change Resets Reference Level 1 Bucket
Reset Reference If Depth 0.03 inches Low for 254 Minutes
Press Any Key (this will return you to the main menu)
```

2.4 Press Function Key F6 - Set All Values in EEPROM

This function allows changing any of the calibration information. If you do not want to make any changes, you can step through each entry by pressing "ENTER," which will leave the same information as displayed. (A "P" entry at Step (i) is required for temperature tracking.)

Sample of screen display:

```

Set All Current Data in Detector
14:14:23                10/24/00
Calibration Parameters
(CNTS - (a) ) * ( (b) / 1000) = inches / .001 FOR CNTS >(c)
(CNTS - (d) ) * ( (e) / 1000) = inches / .001 FOR CNTS >(f)
(CNTS - (g) ) * ( (h) / 1000) = inches / .001
Positive OR Negative Temperature Tracking (P/N) P (i)
DRAIN When Depth In Inches Shown Is Reached
Above K          Half Charge          Full Charge
275.00 (j) _____ 11.00 (k) _____ 11.00 (l)
265.00 (m) _____ 9.00 (n) _____ 11.00 (o)
255.00 (p) _____ 5.00 (q) _____ 9.00 (r)
_____          3.75 (s) _____ 6.75 (t)
Antifreeze Depth 1.750 (u)          3.250 (v)
0.500 (w) Absolute Minimum Depth
0.010 (x) Inches per Bucket Tip
-4.90 (y) Counts/Degree Temperature Coefficient
15 (z) Minutes Delay Before Initial Precip Reported
45 (1) Minutes No Precip To Reset timer
0.5 (2) Sec Power UP 2.0 (3) Sec Sample Time For A/D
1 (4) Counts Step If More Than 5 (5) Counts Change For 9 (6) Loops
1.00 (7) Degrees C change Resets Reference Level 1 (8) Bucket
Reset Reference If Depth 0.03 (9) inches Low for 254 (10) Minutes
Store Levels To RAM? N (11)
Is RAM Present In Unit? N (12)
Serial Output Each Read? N (13)

```

2.4.1 NOTE: Small letters and numbers in parentheses following the values indicate steps where numeric values are to be entered.

Values need to be entered for steps **j - v** only when the gauge is configured to operate in the automatic mode with drain and fill. It may be advantageous to enter values to become accustomed to setting values later on should the gauge be automated.

Temperatures are in degrees Kelvin (where 273°K = 0°C).
 Example: 283° K = 10° C.

2.4.2 The following describes the fields identified by **a - z** and **1 - 13**:

- a** = correction factor (spreadsheet calculation)
offset counts = to -1.0 inches for 7 to 10 inches
- b** = correction factor (spreadsheet calculation)
1/counts per .001 inches for 7 to 10 inches
- c** = Raw counts where third range starts
- d** = correction factor (spreadsheet calculation)
offset counts to -1.0 inches for 4 to 7 inches
- e** = correction factor (spreadsheet calculation)
1/counts per .001 inches for 4 to 7 inches
- f** = Raw counts where second range starts
- g** = correction factor (spreadsheet calculation)
offset counts = to -1.0 inches for 0 to 4 inches
- h** = correction factor (spreadsheet calculation)
1/counts per .001 inches for 0 to 4 inches)
- i** = "P" demonstrates positive temperature tracking. Do not change.

NOTE: STEPS K THROUGH W ARE ONLY FOR GAUGES THAT AUTOMATICALLY DRAIN AND RECHARGE WITH ANTIFREEZE (NOT FOR MANUAL GAUGES)

The following apply to adjustable drain levels when a half charge of antifreeze has been placed in the gauge. (Note Step 4 below, the level for antifreeze half charge):

- k** = max drain level at temperature above that set by Step - **j**
- n** = drain level above temperature set by Step - **m**
- q** = drain level above temperature set by Step - **p**
- s** = min drain level at temperature below that set by Step - **p**

The following apply to adjustable drain levels when a full charge of antifreeze has been placed in the gauge. (Note Step 3 below, the level for antifreeze full charge):

- l** = max drain level at temperature above that set by Step - **j**
- o** = drain level above temperature set by Step - **m**
- r** = drain level above temperature set by Step - **p**
- t** = min drain level at temperature below that set by Step - **p**
- u** =value for **half charge**= 1.75 inches
at temperatures above that set in **j**
- v** = value for **full charge** = 3.25 inches

at temperatures below that set in **j**

w = value for minimum evaporation level = 0.50 inches

x = value per tip output = .01

y = temperature coefficient for your particular gauge. DO NOT CHANGE.

z = time in minutes that first .01 to .02 inches is delayed (**see note following**)

1 = time in minutes before resetting the timer that delays the first .01 to .02 inches as described in **1** above(**see note following**)

2 = time power is applied before sampling the load cell

3 = amount of time load cell is sampled (about 3000 samples)

4, 5, and 6 = parameters for decreasing wind and vibration effects

7 = Number of degrees change to reset Reference Depth to Actual Depth. This reduces false counts caused by temperature effects.

8 = Amount that Reference Depth is reset by a change in temperature described in **7**.

9 = Reference Depth is reset downward by this amount if the Actual Depth remains below the Reference Depth by this amount for the time specified in **10**.

10 = Amount of time Actual Depth is allowed to be below Reference Depth by the amount specified in **9**

11, 12, and 13 = Answer "N" to all three (no need to press "ENTER" after the "N")

2.4.3 Note: To minimize false counts due to wind or rapid temperature changes, the first .01 to .02 inches are delayed. If the counts remain true after the time delay, the pulses are then output.

2.5 Press Function Key F7 - Multiple Unit Logging and Testing

This function allows viewing the raw data values. It also stores the data in a computer file for further analysis and for computing values for calibration correction factors. When in the F-7 mode the computer is controlling the timing and data storage of data from the WMA. The following is a sample of the computer display and appropriate responses (underlined).

Multiple Unit Logging and Testing

(computer prompt)

(your response)

ENTER NUMBER OF UNIT ACTIVATED: 1
ENTER NUMBER OF UNIT ACTIVATED: 0
FILE TO WRITE TO: WMATEST

(You may use whatever name you please. If the file does not exist, it will create it. If it does exist, it will ask if you want to overwrite it.)

SECONDS FOR TAKING MEASUREMENT: 3
SECONDS BETWEEN MEASUREMENTS: 10

(Caution! Do not set less than 10 seconds.)

The PC will then display a screen similar to the one shown below.

```

      MULTIPLE UNIT DATA LOGGING AND TESTING
      9:12:50      11:32      9/12/00

Cnt 5423      (Raw level counts from transducer)
T1d 290.00    (Temperature in degrees Kelvin of load cell)
T1b 286.00    (Temperature in degrees Kelvin of electronics)
In. 2.034     (Inches of solution, calculated from raw counts)
```

2.6 Press Function Key F10 - Exit to DOS

This function key exits all other functions. If you are in the main menu, it will exit P7GACOMM and return to DOS.

Appendix B

Windscreen Assembly

1. Introduction

The NOAH II wind screen is designed to be easily assembled and installed on both the automatic and manual gauges.

2. Parts List

<u>Quantity</u>	<u>Description</u>
2	Bolts, $\frac{3}{8}$ inch x 1 inch
2	Nuts, $\frac{3}{8}$ inch
2	Washers
3	Windscreen support arms
6	Set screws
1	Windscreen, Lexan, three sections
1	Windscreen bracket

3. Assembly

- a. Place the windscreen bracket on the precipitation gauge, with the bottom of the bracket being just above the door.
- b. Place the windscreen support arms into windscreen mounting bracket.
- c. Place the set screws in the windscreen support arm. Insert the curved rod with baffles into the windscreen support arm. The rod should be inserted past the set screw opening.
- e. Tighten the set screws that hold the windscreen rods as each windscreen panel is installed.

- f. Adjust the bracket so the top of the windscreen is 1-1/2 inches above the top of the precipitation gauge.