

DS-6211 Base Station

User Guide

Document Version: V00

Release Date: 03-2013

Copyright Information

Hytera is the trademark or registered trademark of Hytera Communications Co., Ltd. (the Company) in PRC and/or other countries or areas. The Company retains the ownership of its trademarks and product names. All other trademarks and/or product names that may be used in this manual are properties of their respective owners.

The product described in this manual may include the Company's computer programs stored in memory or other media. Laws in PRC and/or other countries or areas protect the exclusive rights of the Company with respect to its computer programs. The purchase of this product shall not be deemed to grant, either directly or by implication, any rights to the purchaser regarding the Company's computer programs. Any of the Company's computer programs may not be copied, modified, distributed, decompiled, or reverse-engineered in any manner without the prior written consent of the Company.

Disclaimer

The Company endeavors to achieve the accuracy and completeness of this manual, but no warranty of accuracy or reliability is given. All the specifications and designs are subject to change without notice due to continuous technology development. No part of this manual may be copied, modified, translated, or distributed in any manner without the express written permission of us.

We do not guarantee, for any particular purpose, the accuracy, validity, timeliness, legitimacy or completeness of the Third Party products and contents involved in this manual.

If you have any suggestions or would like to learn more details, please visit our website at:

<http://www.hytera.com>.

Contents

Documentation Information.....	1
1. Checking Items in the Package.....	2
2. Hardware Description	3
2.1 PDU	3
2.1.1 Specifications.....	3
2.1.2 Rear Panel.....	4
2.2 CHU	4
2.2.1 Introduction.....	4
2.2.2 Specifications.....	5
2.2.3 Front Panel	9
2.2.4 LED Indicator.....	9
2.2.5 Rear Panel.....	10
2.3 CHU Power Supply	11
2.3.1 Introduction.....	11
2.3.2 Specifications.....	11
2.3.3 Front Panel	12
2.3.4 Rear Panel.....	13
2.4 Switch	14
2.4.1 Introduction.....	14
2.4.2 Specifications.....	14
2.4.3 Front Panel	14
2.4.4 LED Indicator.....	15
2.4.5 Rear Panel.....	15
2.5 Router	16
2.5.1 Introduction.....	16
2.5.2 Specifications.....	16
2.5.3 Front Panel	16
2.5.4 LED Indicator.....	17
2.5.5 Rear Panel.....	17
2.6 Server	18
2.6.1 Introduction.....	18
2.6.2 Specifications.....	18
2.6.3 Front Panel	19
2.6.4 Rear Panel.....	19
2.7 PSU	20
2.7.1 Introduction.....	20
2.7.2 Specifications.....	20

2.7.3 Front Panel	21
2.7.4 Rear Panel.....	22
2.8 DIU.....	22
2.8.1 Introduction	22
2.8.2 Specifications.....	22
2.8.3 Front Panel	23
2.8.4 Rear Panel.....	23
2.9 DPU	24
2.9.1 Introduction	24
2.9.2 Specifications.....	24
2.9.3 Front Panel	25
2.9.4 Rear Panel.....	25
2.10 COM	26
2.10.1 Introduction	26
2.10.2 Specifications.....	26
2.10.3 Rear Panel.....	27
3. Hardware Installation	29
3.1 Safety Information.....	29
3.1.1 Electrical Safety	29
3.1.2 Working Aloft.....	29
3.2 Installation Preparation	30
3.2.1 Technical Files	30
3.2.2 Personnel	30
3.2.3 Instruments and Tools.....	30
3.2.4 Unpacking the Base Station.....	31
3.3 Installation Location for the Internal Unit.....	34
3.4 Installation Flow	34
3.5 Wiring Diagram	35
3.6 Installing the Cabinet	39
3.6.1 Determining a Location for the Cabinet	39
3.6.2 Fixing the Cabinet.....	39
3.6.3 Testing the Insulation Performance.....	39
3.7 Installing the Internal Units.....	40
3.7.1 Opening the Front Door and Back Door	40
3.7.2 Removing the Side Door.....	40
3.7.3 Installing the Internal Units.....	41
3.7.4 Connecting the Internal Cables.....	43
3.7.5 Installing the Decorative Unit	44
3.7.6 Installing the Side Door.....	44

3.8 Connecting the External Cables	45
3.8.1 Requirements	45
3.8.2 Cables to Be Connected.....	45
3.9 Performing Post-installation Check.....	45
3.9.1 Requirements	45
3.9.2 Checking the Cabinet	45
3.9.3 Checking the Cable	46
3.9.4 Checking the Power Supply Condition.....	47
3.9.5 Checking the Environment.....	47
4. Basic Operations	49
4.1 Powering up the Base Station.....	49
4.2 Powering off the Base Station.....	49
5. Routine Maintenance	50
5.1 Purpose	50
5.2 Tasks	50
A Abbreviations	51

Figures

Figure 2-1 Rear Panel of PDU.....4

Figure 2-2 Logical Architecture of CHU4

Figure 2-3 Front Panel of CHU9

Figure 2-4 Rear Panel of CHU 11

Figure 2-5 Front Panel of CHU Power Supply 13

Figure 2-6 Rear Panel of CHU Power Supply 13

Figure 2-7 Front Panel of Switch 14

Figure 2-8 Rear Panel of Switch..... 15

Figure 2-9 Front Panel of Router 16

Figure 2-10 Rear Panel of Router 18

Figure 2-11 Front Panel of Server 19

Figure 2-12 Rear Panel of Server..... 20

Figure 2-13 Front Panel of PSU 22

Figure 2-14 Rear Panel of PSU 22

Figure 2-15 Front Panel of DIU 23

Figure 2-16 Rear Panel of DIU 24

Figure 2-17 Front Panel of DPU 25

Figure 2-18 Rear Panel of DPU..... 26

Figure 2-19 Rear Panel of COM..... 28

Figure 3-1 Laying the Wooden Case 32

Figure 3-2 Pulling the Tongue Piece Straight..... 32

Figure 3-3 Removing the Wooden Cover and Side Wooden Plate..... 32

Figure 3-4 Unpacking the Carton 33

Figure 3-5 Installation Locations for Internal Units of 4-Carrier Base Station 34

Figure 3-6 Installation Flow 35

Figure 3-7 Wiring Diagram for 4-carrier Base Station 38

Figure 3-8 Installation Location for Base Station 39

Figure 3-9 Fixing the Bolt 39

Figure 3-10 Opening the Front Door and Back Door 40

Figure 3-11 Removing the Side Door 41

Figure 3-12 Installing the Tray 42

Figure 3-13 Installing the CHU 42

Figure 3-14 Installing the Router 43

Figure 3-15 Installing the COM..... 43

Figure 3-16 Outline of Cable 44

Figure 3-17 Installing the Decorative Unit..... 44

Tables





Table 1-1 Configuration of 4-carrier Base Station	2
Table 2-1 PDU Specifications	4
Table 2-2 Descriptions on Rear Panel of PDU.....	4
Table 2-3 CHU Specifications	9
Table 2-4 Descriptions on Front Panel of CHU.....	9
Table 2-5 Descriptions on CHU Indicators.....	10
Table 2-6 Descriptions on Rear Panel of CHU	11
Table 2-7 CHU Power Supply Specifications	12
Table 2-8 Descriptions on Front Panel of CHU Power Supply.....	13
Table 2-9 Descriptions on Rear Panel of CHU Power Supply	13
Table 2-10 Switch Specifications	14
Table 2-11 Descriptions on Front Panel of Switch	15
Table 2-12 Descriptions on Switch Indicators	15
Table 2-13 Descriptions on Rear Panel of Switch.....	15
Table 2-14 Router Specifications	16
Table 2-15 Descriptions on Front Panel of Router.....	17
Table 2-16 Descriptions on Router Indicators.....	17
Table 2-17 Descriptions on Rear Panel of Router	18
Table 2-18 Server Specifications	19
Table 2-19 Descriptions on Front Panel of Server	19
Table 2-20 Descriptions on Rear Panel of Server.....	20
Table 2-21 PSU Specifications	21
Table 2-22 Descriptions on Rear Panel of PSU.....	22
Table 2-23 DIU Specifications.....	23
Table 2-24 Descriptions on Rear Panel of DIU	24
Table 2-25 DPU Specifications	25
Table 2-26 Descriptions on Rear Panel of DPU.....	26
Table 2-27 COM Specifications	27
Table 2-28 Descriptions on Rear Panel of COM.....	28
Table 3-1 Technical Files	30
Table 3-2 Instruments and Tools.....	31
Table 3-3 Cables to Be Connected.....	45
Table 3-4 Checklist for the Cabinet.....	46
Table 3-5 Checklist for the Cable.....	46
Table 3-6 Checklist for Power Supply Condition.....	47
Table 3-7 Checklist for Environment.....	48

Documentation Information

This section describes the conventions and revision history of this document.

Documentation Conventions

Instructional Icons

Icon	Description
 Tip	Indicates information that can help you make better use of your product.
 Note	Indicates references that can further describe the related topics.
 Caution	Indicates situations that could cause data loss or equipment damage.
 Warning	Indicates situations that could cause minor personal injury.
 Danger	Indicates situations that could cause major personal injury or even death.

Notational Conventions

Convention	Description
“ ”	The quotation marks enclose the name of a software interface element. For example, click “OK”.
Bold	The text in boldface denotes the name of a hardware button. For example, press the PTT key.
->	The symbol directs you to access a multi-level menu. For example, to select “New” from the “File” menu, we will describe it as follows: File -> New.

Revision History

Version	Release Date	Description
V00	03-2013	Initial release

1. Checking Items in the Package

No.	Item	Qty.
1	PDU	1
2	CHU	4
3	CHU Power Supply	2
4	Switch	1
5	Router	1
6	Server	1
7	PSU	1
8	DIU	1
9	DPU	1
10	COM	1
11	Cabinet Kit (including the 37U cabinet, decorative unit, tray and cable)	1

Table 1-1 Configuration of 4-carrier Base Station

2. Hardware Description

The DS-6211 base station realizes the following functions:

- Processing signaling and service
 - On the downlink, the server in the base station receives the data packets from the MSO via the EIB, and sends them to the CHUs via the switch. Then the CHUs generate the downlink RF signals, which are combined via the COM. Finally, the combined signals are sent to the antenna via the duplexer for transmission.
 - On the uplink, the antenna receives the uplink RF signals from the mobile station, and sends them to the DIU via the duplexer. Then the DIU makes several copies of the signals, and sends them to the CHUs for generating data packets. Finally, the generated data packets are sent to the server via the switch, and further sent to the MSO via the EIB.
- Supplying power

The AC power from the mains electricity is divided by the PDU to provide power for the CHU power supply, PSU and other appropriate units in the base station. The CHU power supply converts the AC voltage to DC voltage to power up the CHU, while the PSU converts the AC voltage to DC voltage to power up the DIU and other appropriate units such as router.

2.1 PDU

2.1.1 Specifications

Item		Specification
Power	Input voltage range	120–240V
	Maximum current draw	<ul style="list-style-type: none"> ● 208V@12.8A (UL, CUL) ● 120V@16A (UL, CUL) ● 240V@16A (VDE)
Physical	Dimensions (LXWXD)	447X44.5X57.2mm
	Weight	0.98kg
	Shipping weight	2.36kg
Environmental	Elevation (above MSL)	<ul style="list-style-type: none"> ● Operating: 0–3000m ● Storage: 0–15000m
	Temperature	<ul style="list-style-type: none"> ● Operating: 0–45°C

Item		Specification
		<ul style="list-style-type: none"> Storage: -25°C to 65°C
	Relative humidity	0–95%, non-condensing
Approvals/Standards	UL, CUL, VDE	

Table 2-1 PDU Specifications

2.1.2 Rear Panel

The rear panel of the PDU is shown in Figure 2-1 and described in Table 2-2.

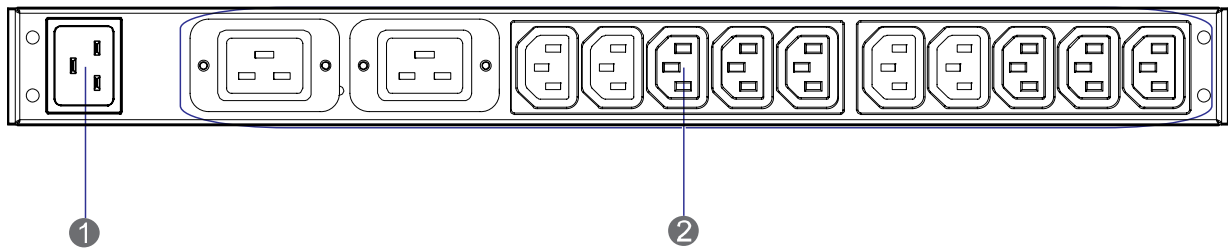

Figure 2-1 Rear Panel of PDU

No.	Name	Description
1	Power Inlet	1 inlet
2	Power Outlet	12 outlets

Table 2-2 Descriptions on Rear Panel of PDU

2.2 CHU

The CHU includes the power amplifier module, exciter module, RX module, channel control board and other mechanical parts. Its logical architecture is shown in Figure 2-2.

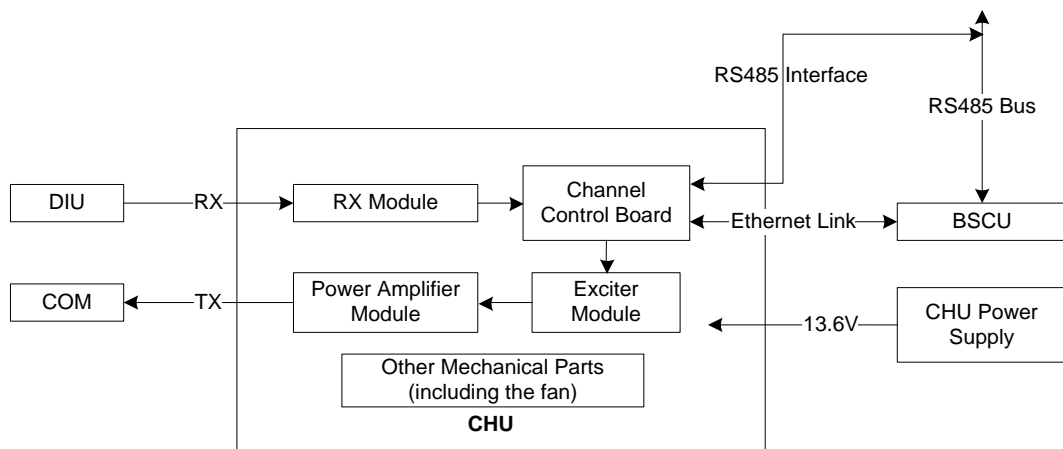

Figure 2-2 Logical Architecture of CHU

2.2.1 Introduction

It is responsible for transmitting and receiving the RF signals and for processing the baseband

information. The base station has multiple CHUs, each of which is responsible for processing the information on one carrier.

2.2.2 Specifications

Item		Specification	
General	Frequency range	400–470MHz	
	Channel capacity	16	
	Normal operating voltage	13.6V	
	Extreme operating voltage	<ul style="list-style-type: none"> ● Low: 11.0V ● High: 15.6V 	
	Current drain	<ul style="list-style-type: none"> ● Standby: $\leq 1.0A$ ● Transmit: $\leq 11A$ 	
	Channel spacing	12.5k	
	Antenna impedance	50 Ω	
	Duty cycle	100%	
	Operating temperature	–30 $^{\circ}C$ to +60 $^{\circ}C$	
	Storage temperature	–40 $^{\circ}C$ to +85 $^{\circ}C$	
	Dimensions (WXHXL)	88x483x366mm	
	Weight	8.5kg	
	ESD	IEC-801-2KV	
	LCD Display	220*176pixels, 262000 color, 2.0inch, 4rows	
Receiver	Receiver maximum usable sensitivity (BER)	Normal	<ul style="list-style-type: none"> ● –110dBm/BER1% ● –118 dBm/BER5%
		Extreme	–115 dBm/BER5%
	Receiver Ultimate (BER) sensitivity	–85dBm/BER0%	
	Receiver BER at high RF input	10dBm/ BER0%	
Receiver Dynamic Faded (BER)	–108dBm/BER5%		

Item		Specification
sensitivity (8KM/H and 100KM/H)		
Receiver maximum sensitivity	analog usable Spec	<ul style="list-style-type: none"> ● $\leq -118\text{dBm}$ (12 dB SINAD) ● $\leq -112\text{dBm}$ (20 dB SINAD)
	Typical	-119dBm
Co-channel rejection		12.5kHz -12dB to 0dB
Adjacent selectivity	channel 12.5K	$\geq 65\text{dB}$
	12.5K/digital	$\geq 60\text{dB}$
Spurious response rejection		$\geq 80\text{dB}$
Intermodulation		<ul style="list-style-type: none"> ● ETSI: $\geq 70\text{dB}$ ● TIA603: $\geq 75\text{dB}$
Blocking		$\geq 90\text{dB}$
Conducted Spurious Emission		$\leq -57\text{dBm}$
Radiated Spurious Emission		<ul style="list-style-type: none"> ● $-57\text{dBm} < 1\text{GHz}$ ● $-47\text{dBm} > 1\text{GHz}$
Rated audio Power	Rated Power (8 Ω)	0.5W
	Maximum Power	$1.0\text{W} \pm 20\%$
Rated audio distortion	Analog	$\leq 3\%$
	Digital	$\leq 5\%$
Receiver SNR	Analog	<ul style="list-style-type: none"> ● $\geq 40\text{dB}$ @ 12.5kHz ● $\geq 43\text{dB}$ @ 20kHz ● $\geq 45\text{dB}$ @ 2kHz
	Digital	$\geq 40\text{dB}$

Item			Specification
	Receiver audio response		-3dB to +1dB
	Receiver synthesizer lock time	1st Lo	7ms
		2nd Lo	5ms
Transmitter	Frequency stability		$\leq \pm 0.5\text{ppm}$
	Transmitter output power		5-50W
	Occupied bandwidth	12.5kHz	8.5kHz@3dB
	Adjacent channel power	12.5kHz	$\geq 60\text{dB}$
	Conducted Spur and harmonic	$\leq 1\text{GHz}$	<ul style="list-style-type: none"> ● $\leq -6\text{dBm}$ (operating) ● $\leq -57\text{dBm}$ (standby)
		$> 1\text{GHz}$	<ul style="list-style-type: none"> ● $\leq -30\text{dBm}$ (operating) ● $\leq -47\text{dBm}$ (standby)
	Radiated Spur and harmonic	$\leq 1\text{GHz}$	<ul style="list-style-type: none"> ● $\leq -36\text{dBm}$ (operating) ● $\leq -57\text{dBm}$ (standby)
		$> 1\text{GHz}$	<ul style="list-style-type: none"> ● $\leq -30\text{dBm}$ (operating) ● $\leq -47\text{dBm}$ (standby)
	Transmit modulation accuracy	4FSK room temp	$\leq 5\%$
		extreme temp	$\leq 10\%$
	Transmit maximum deviation	4FSK room temp	3.7kHz
		extreme temp	3.85kHz
	4FSK Transmit BER		0%
Transmit FSK and Magnitude Error		5%/1%	
4FSK Transmit Modulation Emission Spectrum		Compliant with the interior standard	

Item			Specification
	Tx Audio distortion	analog	≤3%
		Digital	≤5%
	Tx Audio S/N	analog	<ul style="list-style-type: none"> ● ≥40dB@12.5kHz ● ≥43dB@20kHz ● ≥45dB@25kHz
		Digital	≥40dB
	Transmit audio distortion		-3dB to +1dB
	Transmit transient response		Compliant with the ETSI and TIA/EIA standard
	Transmit modulation limiting	12.5kHz	≤2.5kHz
	FM modulation mode (N/A)		
	4FSK modulation mode	12.5k (only data)	7K60FXD
		12.5k (both data and voice)	7K60FXW
	CTCSS/DCS Deviation	12.5kHz	350-600Hz
	Duplex	60% Repeater Audio Deviation(-30 °C ~ +60)	12.5kHz
Repeater Audio Distortion		≤3%	
Repeater open sensitivity		<ul style="list-style-type: none"> ● -124 to -118dBm (Normal) ● -122 to -116dBm (Tight) 	
Repeater close sensitivity		<ul style="list-style-type: none"> ● -126 to -120dBm (Normal) ● -124 to -118dBm (Tight) 	
Repeater Audio		analog	<ul style="list-style-type: none"> ● ≥43dB@25kHz

Item		Specification	
	SNR		● $\geq 40\text{dB}@12.5\text{kHz}$
		Digital	$\geq 40\text{dB}$
SYNC	Carrier synchronous range	analog	$\pm 4\text{kHz}$
		Digital	$\pm 8\text{kHz}$

Table 2-3 CHU Specifications

2.2.3 Front Panel

The front panel of the CHU is shown in [Figure 2-3](#).

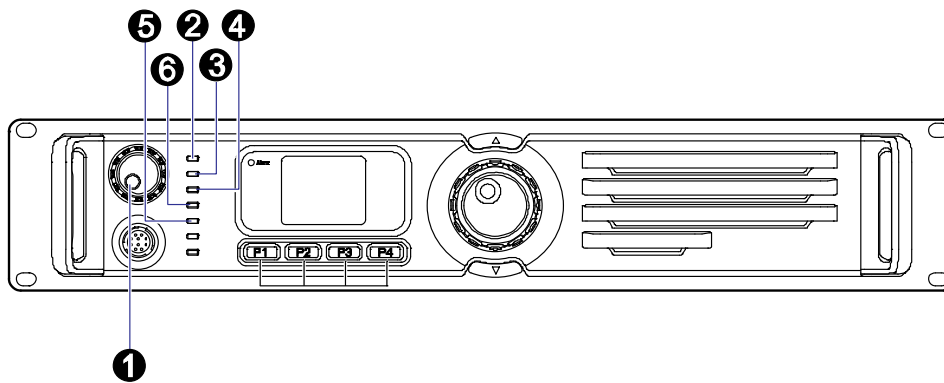

Figure 2-3 Front Panel of CHU

No.	Name	No.	Name
1	PWR Indicator	2	Digital Indicator
3	TX-A Indicator	4	RX-A Indicator
5	TX-B Indicator	6	RX-B Indicator

Table 2-4 Descriptions on Front Panel of CHU

2.2.4 LED Indicator

The CHU indicators are described in [Table 2-5](#).

LED Indicator	Color	Status	Description
PWR Indicator	Yellow	Glowing solidly	The CHU is supplied with power normally.
		Off	The CHU is not supplied with power normally.
Digital Indicator	Blue	Flashing	The CHU runs normally.

LED Indicator	Color	Status	Description
		Off	The CHU does not run normally.
TX-A Indicator	Red	Flashing	The CHU is transmitting data on time slot 1.
		Off	No data is being transmitted on time slot 1.
RX-A Indicator	Yellow	Flashing	The CHU is receiving carrier signals on time slot 1.
		Off	No carrier signal is being received on time slot 1.
TX-B Indicator	Red	Flashing	The CHU is transmitting data on time slot 2.
		Off	No data is being transmitted on time slot 2.
RX-B Indicator	Yellow	Flashing	The CHU is receiving carrier signals on time slot 2.
		Off	No carrier signal is being received on time slot 2.

Table 2-5 Descriptions on CHU Indicators

 **Note**

If the **PWR** indicator is glowing solidly and the **Digital** indicator is flashing, it means the CHU goes to the sleep mode. In this mode, the CHU can still receive inbound data (the **RX-A/RX-B** indicator flashes).

2.2.5 Rear Panel

The rear panel of the CHU is shown in [Figure 2-4](#) and described in [Table 2-6](#).

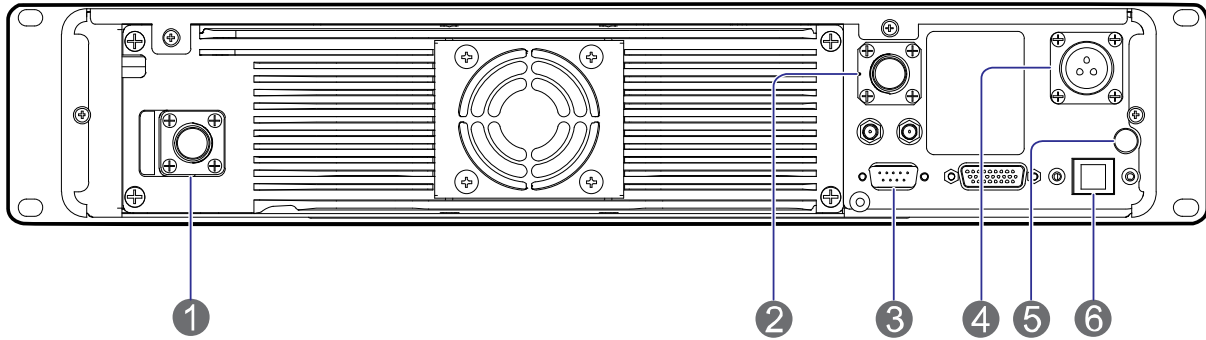

Figure 2-4 Rear Panel of CHU

No.	Name	Description
1	TX Antenna Interface	N connector (female)
2	RX Antenna Interface	N connector (female)
3	Monitor Interface	DB9 connector
4	DC Power Inlet	13.6V±5% DC, ≤170W
5	Ground Terminal	Screw terminal
6	Ethernet Interface	RJ45 connector

Table 2-6 Descriptions on Rear Panel of CHU

2.3 CHU Power Supply

2.3.1 Introduction

Each CHU power supply can power up two CHUs.

2.3.2 Specifications

Each CHU power supply contains two power modules, whose specifications are described in [Table 2-7](#).

Item		Specification
Input Property	Operating Voltage	100/220V AC
	Extreme Voltage	90–264V AC
	Frequency	47–63Hz
	Max. Current	<6.5A (input voltage: 100–130V AC)
	Max. Surge Current	<50A (230V AC)
Output Property	Voltage	13.8V DC
	Rated Current	16A

Item		Specification
	Efficiency	≥82% (input voltage: 230V AC)
	Ripple Voltage	<150mVp-p
Environment Property	Normal Operating Temperature	15°C to 35°C
	Extreme Operating Temperature	-30°C to +60°C
	Storage Temperature	-40°C to +85°C
	Operating Humidity	<90%RH
	Altitude	<2000m
	MTBF	100,000 hours
	Vibration	10–500Hz, 2G, 60 minutes, X/Y/Z directions
Protection Property	Over-voltage Protection	15–18V, self-recover
	Over-power Protection	Self-recover
	Short Circuit Protection	Hiccup mode
Safety Requirement	Standard	CE60950/UL60950
EMC	EMI	EN 55022 class B
	EMS	EN 55024
Standby Power Consumption		≤5W (input voltage: 240V AC)

Table 2-7 CHU Power Supply Specifications

2.3.3 Front Panel

The front panel of the CHU power supply is shown in [Figure 2-5](#) and described in [Table 2-8](#).

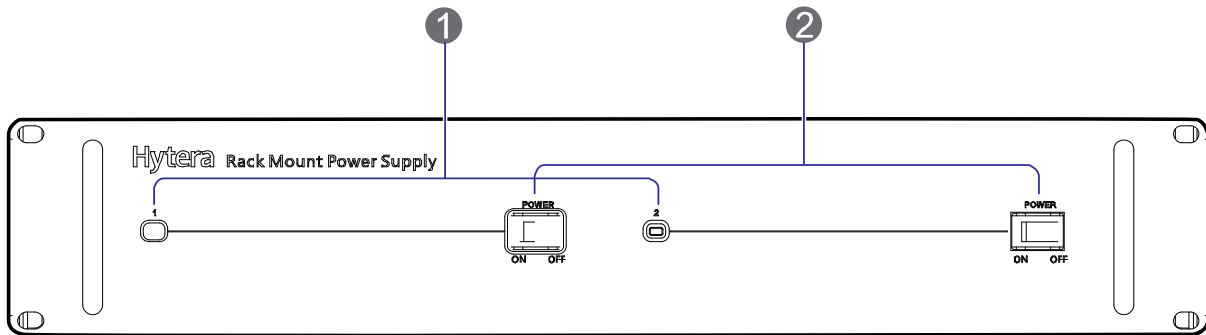

Figure 2-5 Front Panel of CHU Power Supply

No.	Name	Description
1	PWR Indicator	If the PWR indicator glows green solidly, it means the corresponding power module supplies power normally; if the indicator goes off, it means the corresponding power module does not supply power normally.
2	On/Off Switch	Double-pole-double-throw switch

Table 2-8 Descriptions on Front Panel of CHU Power Supply

2.3.4 Rear Panel

The rear panel of the CHU power supply is shown in [Figure 2-6](#) and described in [Table 2-9](#).

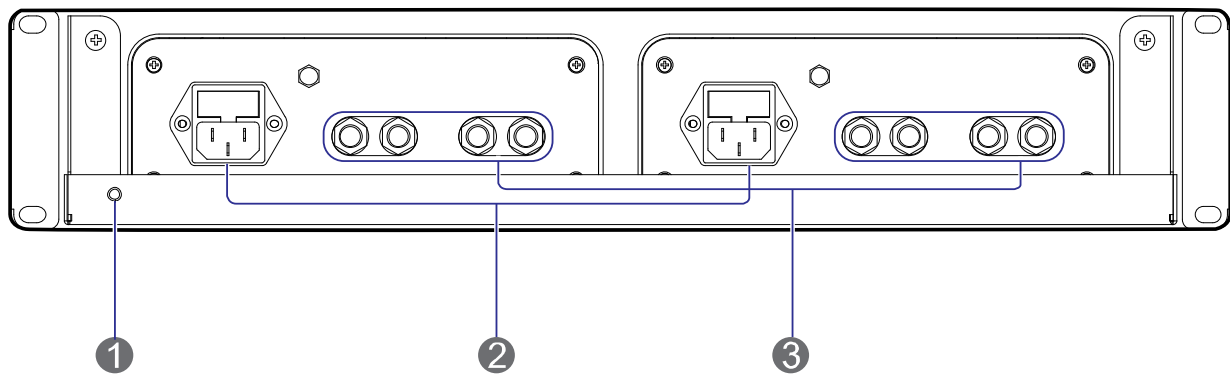

Figure 2-6 Rear Panel of CHU Power Supply

No.	Name	Description
1	Ground Terminal	$\leq 0.1\Omega$, $\geq 2.5\text{mm}^2$, screw terminal
2	AC Power Inlet	110/220V AC, $\leq 486\text{W}$, 3-pin
3	DC Power Outlet	$13.6\text{V}\pm 5\%$ DC, 2 paths, $\geq 170\text{W}/\text{path}$, terminal connector

Table 2-9 Descriptions on Rear Panel of CHU Power Supply

2.4 Switch

2.4.1 Introduction

The switch provides media for communication within the base station.

2.4.2 Specifications

Item	Specification
Standard and Protocol	<ul style="list-style-type: none"> ● IEEE 802.3 10BASE-T Ethernet ● IEEE 802.3u 100BASE-TX Fast Ethernet ● CSMA/CD Ethernet
Data Transmission Rate	<ul style="list-style-type: none"> ● Ethernet: 10Mbps (half duplex), 20Mbps (full duplex) ● Fast Ethernet: 100Mbps (half duplex), 200Mbps (full duplex)
Network Media	<ul style="list-style-type: none"> ● 10Base-T: UTP/STP Cat3 or above (≤100m) ● 100Base-TX: UTP/STP Cat5 or above (≤100m)
Transmission Way	Store and forward
AC Input	100–240V 50/60Hz 0.6A
Operating Temperature	0°C to +40°C
Storage Temperature	–40°C to +70°C
Operating Humidity	10%–90%RH (non-condensing)
Storage Humidity	5%–90%RH (non-condensing)

Table 2-10 Switch Specifications

2.4.3 Front Panel

The front panel of the switch is shown in [Figure 2-7](#) and described in [Table 2-11](#).

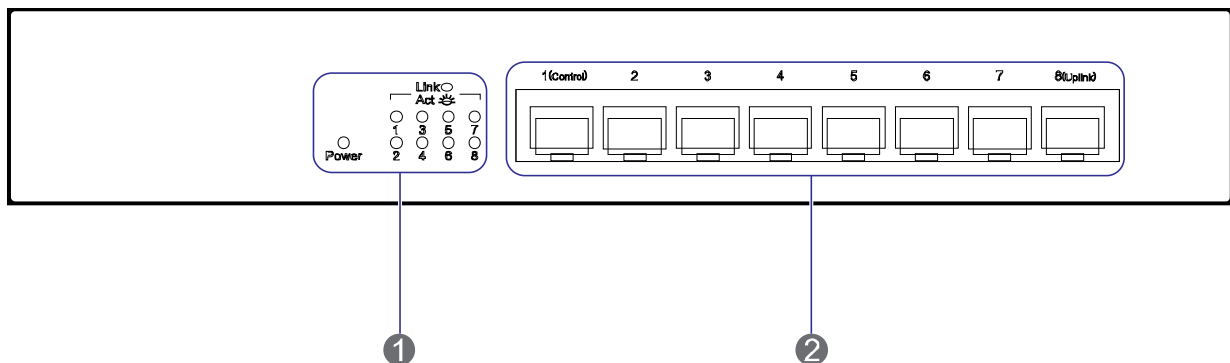

Figure 2-7 Front Panel of Switch

No.	Name	No.	Name
1	LED Indicator	2	Ethernet Interface

Table 2-11 Descriptions on Front Panel of Switch

2.4.4 LED Indicator

The switch indicators are described in [Table 2-12](#).

LED Indicator	Color	Status	Description
Power	Red	Glowing solidly	The switch is supplied with power normally.
		Off	The switch is not supplied with power normally.
Link/Act	Green	Glowing solidly	A device is connected to the corresponding interface.
		Flashing	Data is being received or sent via the corresponding interface.
		Off	No device is connected to the corresponding interface.

Table 2-12 Descriptions on Switch Indicators

2.4.5 Rear Panel

The rear panel of the switch is shown in [Figure 2-8](#) and described in [Table 2-13](#).

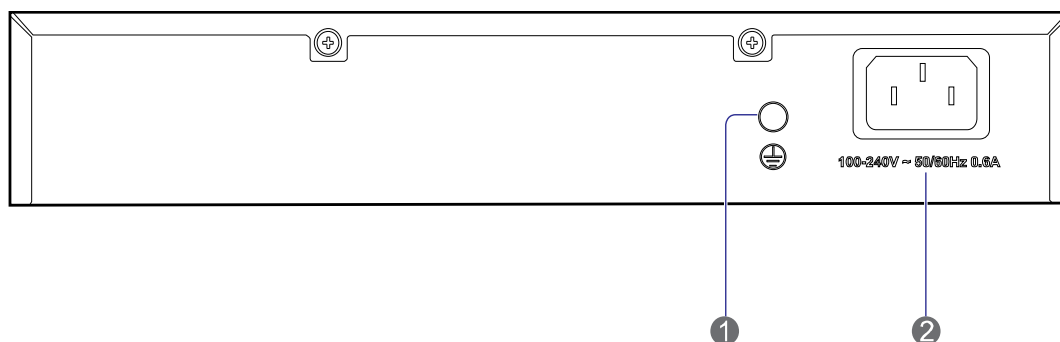

Figure 2-8 Rear Panel of Switch

No.	Name	Description
1	Ground Terminal	Screw
2	Power Inlet	100–240V AC 50/60Hz 0.6A

Table 2-13 Descriptions on Rear Panel of Switch

2.5 Router

2.5.1 Introduction

The router provides media for communication between the base station and MSO.

2.5.2 Specifications

Item	Specification
Repeat Performance	150Kpps
Memory	256M (DDR2)
Flash	256M
USB	1
CON	1
Communication Interface	2 megabit Ethernet interfaces, 4 megabit switch interfaces
Max. Power Consumption	12W
Rated Input Voltage	100–240V 50/60Hz
Ambient Temperature	Ambient Temperature
Ambient Humidity	Ambient Humidity

Table 2-14 Router Specifications

2.5.3 Front Panel

The front panel of the router is shown in [Figure 2-9](#) and described in [Table 2-15](#).

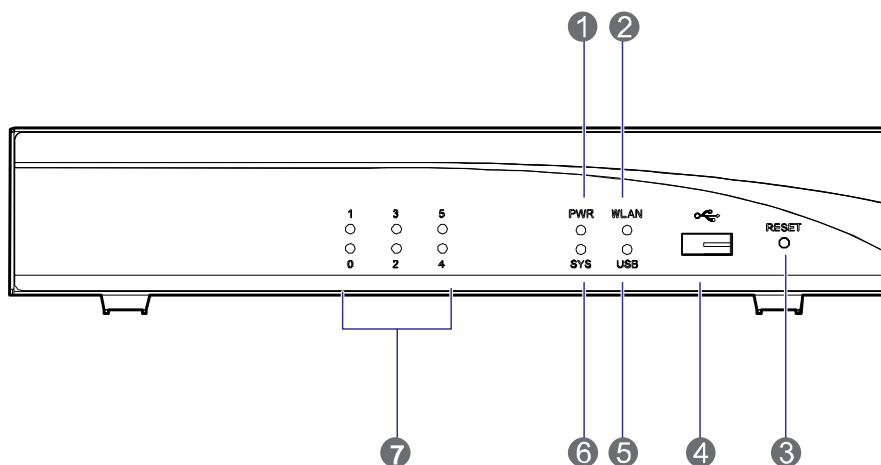

Figure 2-9 Front Panel of Router

No.	Name	No.	Name
1	PWR Indicator	2	WLAN Indicator (not used)
3	RESET Button	4	USB Port
5	USB Indicator	6	SYS Indicator
7	Ethernet Indicator	/	/

Table 2-15 Descriptions on Front Panel of Router

2.5.4 LED Indicator

The router indicators are described in [Table 2-16](#).

LED Indicator	Status	Description
PWR	Glowing solidly	The router is supplied with power normally.
	Off	The router is not supplied with power normally.
SYS	Green LED flashing rapidly	The router is starting.
	Green LED flashing slowly	The router is running normally.
	Yellow LED flashing rapidly	The router malfunctions.
	Off	The router runs abnormally.
0-5	Off	The Ethernet is not connected.
	Glowing solidly	The Ethernet is connected.
	Flashing	Data is being transferred between the router and Ethernet.
USB	Glowing solidly	The USB port is in use.
	Off	The USB port is not in use.

Table 2-16 Descriptions on Router Indicators

2.5.5 Rear Panel

The rear panel of the router is shown in [Figure 2-10](#) and described in [Table 2-17](#).

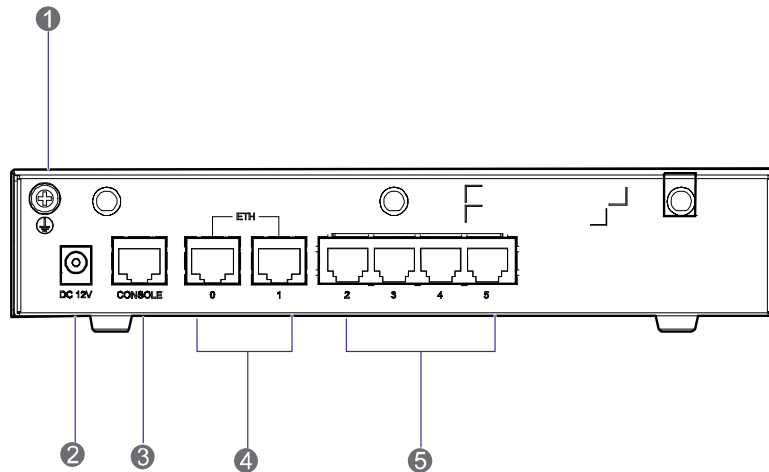

Figure 2-10 Rear Panel of Router

No.	Name	Purpose
1	Ground Terminal	To connect with the ground cable.
2	Power Inlet	To connect with the power adapter.
3	Console Interface	To connect with the PC via the serial cable.
4	Fixed Ethernet Interface (0–1)	Uplink 3-layer Ethernet interface to connect with the WAN.
5	Fixed Switch Interface (2–5)	Downlink 2-layer Ethernet interface to connect with the PC or switch.

Table 2-17 Descriptions on Rear Panel of Router

2.6 Server

2.6.1 Introduction

It is responsible for mobility management, call control, radio resource management and interface control between the base station and MSO.

2.6.2 Specifications

Item	Specification
Form Factor	RACK
CPU Frequency	3.10GHz
Processors	Quad-core Intel® Xeon® E-1220 processors
Processor Sockets	1
Front Side Bus or HyperTransport	DMI (Direct Media Interface)
Cache	8MB

Item	Specification
Chipset	Intel® C216 chipset
Memory	4GB DDR3 1333MHz
I/O Slots	1 PCIe x16 G2 slot
Hard Drives	3.5 inch SATA (7.2K rpm): 500GB
Network Interface Cards	Dual Port Adapter, Gigabit Ethernet NIC, PCIe x4
Power Supply	Single-cabled power supply (250W)
Video	Matrox® G200eW w/ 8MB memory
Remote Management	iDRAC6 optional
Operating Systems	OS-LINUX

Table 2-18 Server Specifications

2.6.3 Front Panel

The front panel of the server is shown in [Figure 2-11](#) and described in [Table 2-19](#).

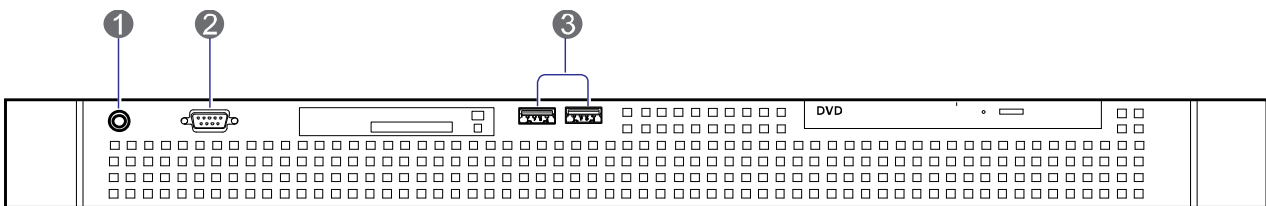

Figure 2-11 Front Panel of Server

No.	Name	No.	Name
1	On/Off Switch	2	VGA Connector
3	USB Port	/	/

Table 2-19 Descriptions on Front Panel of Server

2.6.4 Rear Panel

The rear panel of the server is shown in [Figure 2-12](#) and described in [Table 2-20](#).

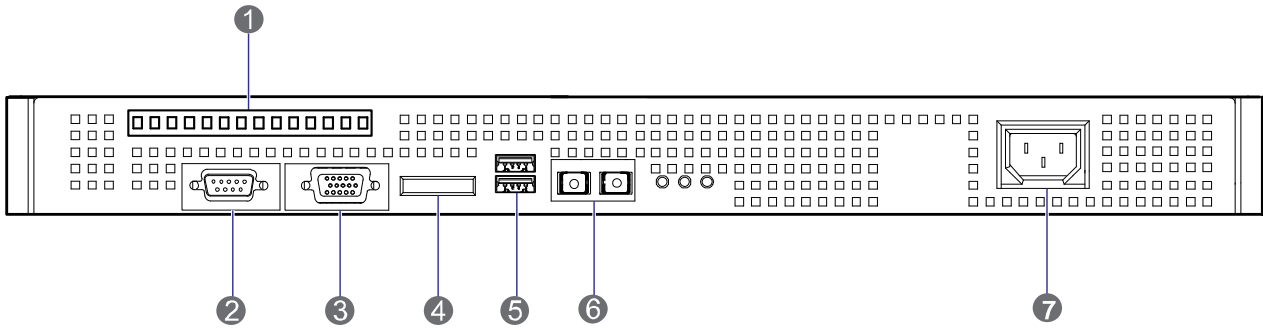

Figure 2-12 Rear Panel of Server

No.	Name	No.	Name
1	PCIe Interface	2	Serial Port
3	VGA Connector	4	E-SATA Interface
5	USB Port	6	100/1000 Mbps Ethernet Interface
7	AC Power Inlet	/	/

Table 2-20 Descriptions on Rear Panel of Server

2.7 PSU

2.7.1 Introduction

The PSU converts the AC voltage to DC voltage, to supply the internal units in the base station.

2.7.2 Specifications

Item		Specification
Input Property	Normal Operating Voltage	100/220V AC
	Extreme Operating Voltage	85–265V AC
	Frequency	47–63Hz
	Max. Current	<4A (input voltage: 115V AC)
	Max. Surge Current (<2ms)	<30A (115V AC), <50A (230V AC)
Output Property	Voltage	12V
	Max. Current	10A

Item		Specification
	Max. Power	120W
	Switching Frequency	100KHz
	Efficiency	$\geq 86\%$
	Hold Time	$\geq 10\text{ms}$
	Ripple Voltage	$< 64\text{mVp-p}$
Environment Property	Normal Operating Temperature	15°C to 35°C
	Extreme Operating Temperature	-30°C to 60°C
	Storage Temperature	-40°C to 85°C
	Operating Humidity	$< 95\%RH$
	Altitude	$< 2000\text{m}$
	MTBF	100,000 hours
	Vibration	10–500Hz, 2G, 60 minutes, X/Y/Z directions
Protection Property	Over-voltage Protection	Self-recover via the clamping diode
	Over-power Protection	Self-recover
	Short Circuit Protection	Self-recover
Safety Requirement	Standard	CE60950/UL60950
EMC	EMI	EN 55022 class B
	EMS	EN 55024

Table 2-21 PSU Specifications

2.7.3 Front Panel

The front panel of the PSU is shown in [Figure 2-13](#).

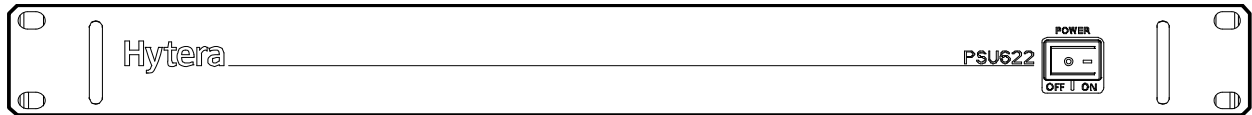

Figure 2-13 Front Panel of PSU

2.7.4 Rear Panel

The rear panel of the PSU is shown in [Figure 2-14](#) and described in [Table 2-22](#).

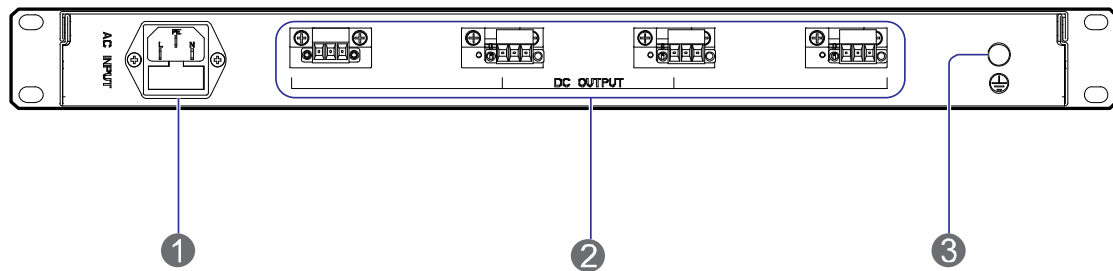

Figure 2-14 Rear Panel of PSU

No.	Name	Description
1	AC Power Inlet	110/220V AC, ≤120W, 3-pin
2	DC Power Outlet	12V±5% DC, terminal connector
3	Ground Terminal	≤0.1Ω, ≥2.5mm ² , screw terminal

Table 2-22 Descriptions on Rear Panel of PSU

2.8 DIU

2.8.1 Introduction

It divides the RX signals into four parts and provides them to the CHUs respectively.

2.8.2 Specifications

Item	Specification under Normal Temperature (+15°C to +35°C)	Specification under Extreme Temperature (-30°C to +60°C)
Frequency Range	400–470MHz	
Operating Bandwidth	5MHz	
In-band Gain	7.5±0.5dB	7.5±1.5dB
Noise Figure	≤1.5dB	≤1.8dB
Input VSWR	≤1.40	≤1.50
Output VSWR	≤1.30	≤1.50
In-band Ripple (P-P)	≤0.5dB	≤0.7dB

Item	Specification under Normal Temperature (+15°C to +35°C)	Specification under Extreme Temperature (-30°C to +60°C)
Port Unbalance (P-P)	$\leq 1.0\text{dB}$	
Isolation	$\geq 23\text{dB}$	$\geq 20\text{dB}$
Cross Modulation	$\geq -60\text{dBc}@-20\text{dBm}$	$\geq -57\text{dBc}@-20\text{dBm}$
Operating Voltage	12–13.8V DC	
Operating Current	$\leq 300\text{mA}$	
Allowed Input Power	$\leq 10\text{dBm}$	
Impedance	50Ω	
Connector Type	N connector (female)	
Operating Humidity	5%–95%RH	
Operating Temperature	-30°C to +60°C	
Storage Temperature	-40°C to +85°C	
Max. Power Consumption	4W	

Table 2-23 DIU Specifications

2.8.3 Front Panel

The front panel of the DIU is shown in [Figure 2-15](#).

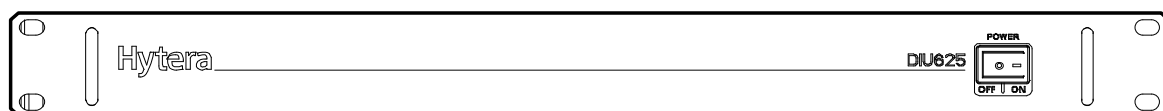

Figure 2-15 Front Panel of DIU

2.8.4 Rear Panel

The rear panel of the DIU is shown in [Figure 2-16](#) and described in [Table 2-24](#).

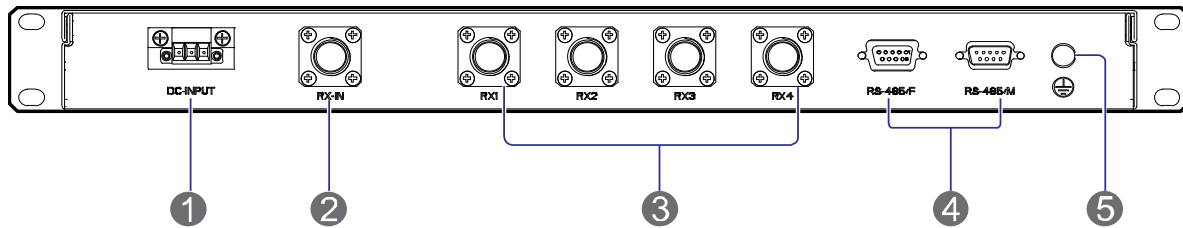

Figure 2-16 Rear Panel of DIU

No.	Name	Description
1	DC Power Inlet	12V DC, ≤15W, 3-pin
2	RF Input Interface	N connector (female)
3	RF Output Interface	To connect with the CHU. N connector (female)
4	Monitor Interface	RS485 interface, DB9 connector (male/female)
5	Ground Terminal	≤0.1Ω, ≥2.5mm ² , screw terminal

Table 2-24 Descriptions on Rear Panel of DIU

2.9 DPU

2.9.1 Introduction

The duplexer realizes the following functions:

- On the uplink, the duplexer sends the RX signal from the antenna to the DIU via the RX interface.
- On the downlink, the duplexer sends the TX signal from the COM to the antenna via the TX interface

2.9.2 Specifications

Item		Specification under Normal Temperature (+15°C to +35°C)	Specification under Extreme Temperature (–30°C to +60°C)
Frequency Range		400–470MHz	
Operating Bandwidth		5MHz	
Duplex Spacing		10MHz	
Insertion Loss	350–420MHz	≤1.1dB	≤1.3dB
	420–480MHz	≤1.2dB	≤1.4dB
In-band Ripple (P-P) within 5MHz		≤0.4dB	≤0.6dB
Input/Output VSWR		≤1.25	≤1.50
Out-of-band	Out of band:	RX: ≥80dB	RX: ≥75dB

Item		Specification under Normal Temperature (+15°C to +35°C)	Specification under Extreme Temperature (-30°C to +60°C)
Rejection	+5MHz	TX: ≥60dB	TX: ≥55dB
	Out of band: -5MHz	RX: ≥60dB TX: ≥80dB	RX: ≥55dB TX: ≥75dB
	Out of band: +10MHz	RX: ≥80dB TX: ≥75dB	RX: ≥75dB TX: ≥70dB
	Out of band: -10MHz	RX: ≥75dB TX: ≥80dB	RX: ≥70dB TX: ≥75dB
Isolation	RX-TX Band	≥50dB	≥45dB
	RX Band	≥80dB	≥75dB
	TX Band	≥80dB	≥75dB
OIP3		≥80dBm (Δf=250KHz)	
Operating Temperature		+15°C to +35°C	-30°C to +75°C
Storage Temperature		-40°C to +85°C	
Operating Humidity		5%–95%	
Impedance		50Ω	
Connector Type		N connector (female)	

Table 2-25 DPU Specifications

2.9.3 Front Panel

The front panel of the DPU is shown in [Figure 2-17](#).

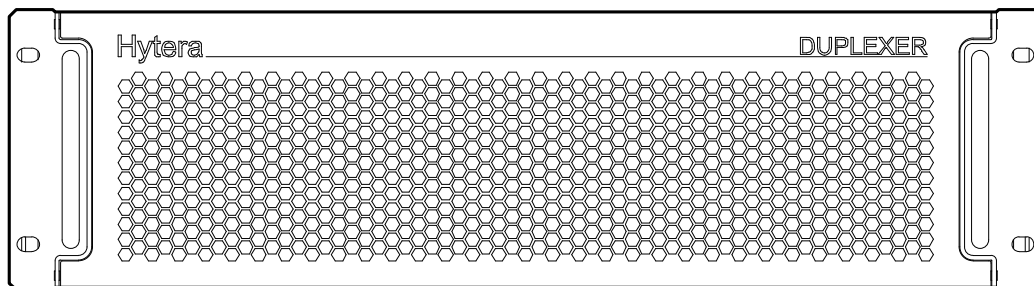

Figure 2-17 Front Panel of DPU

2.9.4 Rear Panel

The rear panel of the DPU is shown in [Figure 2-18](#) and described in [Table 2-26](#).

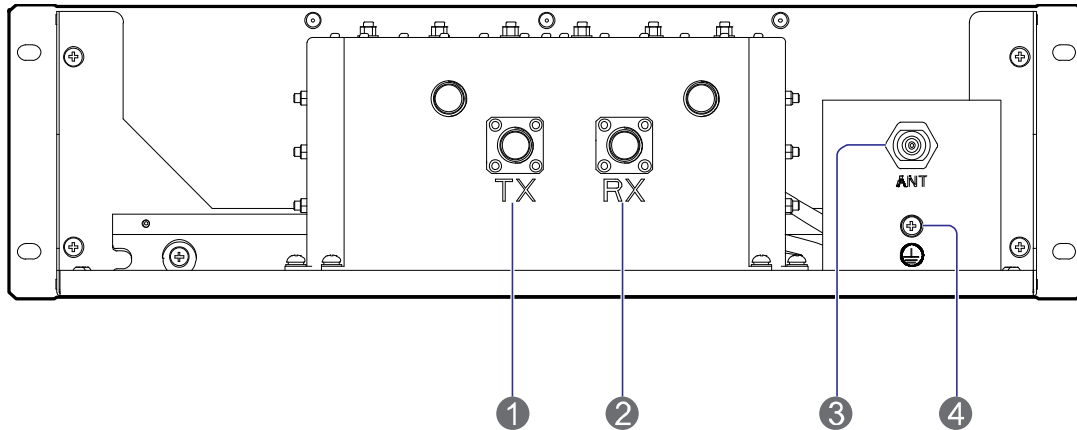

Figure 2-18 Rear Panel of DPU

No.	Name	Description
1	TX Input Interface	N connector (female)
2	RX Output Interface	N connector (female)
3	Duplex Interface	N connector (female)
4	Ground Terminal	$\leq 0.1\Omega$, $\geq 2.5\text{mm}^2$, screw terminal

Table 2-26 Descriptions on Rear Panel of DPU

2.10 COM

2.10.1 Introduction

It combines the signals received from multiple CHUs, and sends them to the duplexer via the output interface.

2.10.2 Specifications

Item	Specification under Normal Temperature (+15°C to +35°C)	Specification under Extreme Temperature (-30°C to +60°C)
Frequency Range	400–470MHz	
Operating Bandwidth	5MHz	
Channel Spacing	$\geq 250\text{kHz}$	
Channel Capacity	4	
Insertion Loss	$\leq 3.0\text{dB}$	$\leq 3.5\text{dB}$

Item		Specification under Normal Temperature (+15°C to +35°C)	Specification under Extreme Temperature (-30°C to +60°C)
Out-of-band Rejection	Out of band: ±250kHz	≥10dB	/
	Out of band: ±500kHz	≥15dB	/
VSWR	Input	≤1.25	≤1.50
	Output	≤1.50	≤1.80
Isolation	Isolation between Input Interfaces	≥75dB	
	Reverse Isolation	≥65dB	
Intermodulation Attenuation		≤-65@2CH (Pin=47dBm, Δf=250kHz)	
Harmonics Suppression		≥80dBc	
Mean Power		≥100W (per channel)	
Operating Temperature		+15°C to +35°C	-30°C to +75°C
Storage Temperature		-40°C to +85°C	
Operating Humidity		5%–95%RH	
Impedance		50Ω	
Connector Type		N connector (female)	

Table 2-27 COM Specifications

2.10.3 Rear Panel

The rear panel of the COM is shown in [Figure 2-19](#) and described in [Table 2-28](#).

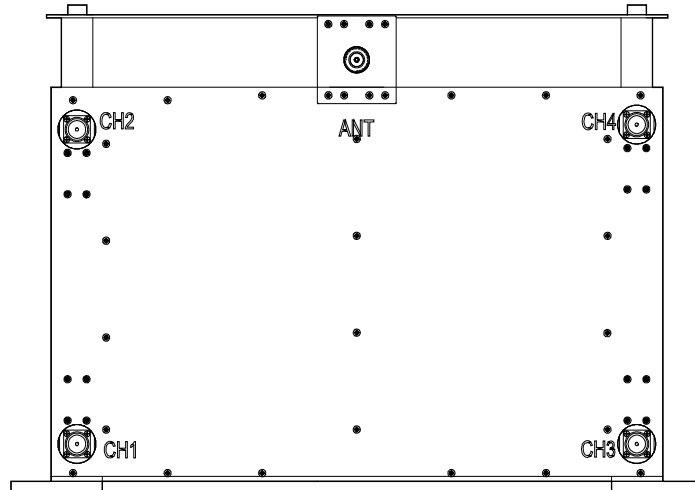

Figure 2-19 Rear Panel of COM

Name	Description	Remark
CH1	Carrier input interface 1	N connector (female)
CH2	Carrier input interface 2	N connector (female)
CH3	Carrier input interface 3	N connector (female)
CH4	Carrier input interface 4	N connector (female)
ANT	Combined output interface	N connector (female)

Table 2-28 Descriptions on Rear Panel of COM

3. Hardware Installation

3.1 Safety Information

Before performing any operation, read the following precautions and operation instructions carefully to ward off potential risks.

3.1.1 Electrical Safety



Danger

Direct contact or indirect contact (through moist objects) with the high voltage or mains electricity may result in fatal danger.

- Never wear conductive objects such as watches, bracelets or rings during operation.
- Do use special tools during high voltage or AC operations.
- Take necessary measures to prevent entry of moisture into the equipment operating under moist environment.
- Make sure the equipment is well grounded to avoid damage as a result of lightning strikes.
- Disconnect the equipment from the power supply before installing or uninstalling it.
- Check the label on the cable to ensure correct connection.
- Make sure that the equipment is well grounded before connecting it to the power supply.
- Disconnect the equipment from the power supply if you find water or other liquids on the cabinet.
- Make sure all switches of the power distribution box are toggled to the “Off” position before installing any unit in the cabinet.

3.1.2 Working Aloft



Warning

Exert sufficient cautions to prevent any object from falling when working aloft.

- Take sound safety actions such as wearing the helmet and safety belt properly.
- Do wear heat-retaining clothes for working in cold areas.
- Make sure that the ladder is safe for use, and overload is strictly prohibited.
- The slant of the ladder is suggested to be 75°. When using a ladder, place it on a stable ground, and take protective measures on the base part of the ladder for skid resistance.
- Handle and use all instruments and tools with care to avoid falling.

3.2 Installation Preparation

3.2.1 Technical Files

The technical files required for the hardware installation are listed in [Table 3-1](#).

File Type	File Name	Description
Instructional file for installation	Network Planning Drawing	Provided by the R&D engineers or marketing personnel
	Site Survey Report	Provided by the investigator according to the on-site investigation
Guidebook	DS-6211 Lite Digital Trunking System Product Description	Shipped with the equipment
	DS-6211 Base Station Hardware Description	
	DS-6211 Base Station Hardware Installation Guide	
Other file	Packing List	Shipped with the equipment

Table 3-1 Technical Files



Note

The Project Construction Scheme may be required for the hardware installation according to the actual needs.

3.2.2 Personnel

Only the qualified personnel are allowed to install and configure the equipment. The number of required engineers is subject to the specific project.

3.2.3 Instruments and Tools

Before hardware installation, you shall prepare the instruments and tools listed in [Table 3-2](#).

General Tools	Hex screwdriver (T9), slot type screwdriver (2#), Phillips screwdriver (PH0, PH2), 8" wrench (2 pcs), 15" wrench (2 pcs), expanding pliers, sealant gun, electric iron, diagonal pliers, claw hammer, paper knife, power strip and A type ladder
Special Tools	Anti-static wrist strap, cable peeler, crimping pliers and terminal pliers

Meters	Multimeter and power meter
---------------	----------------------------

Table 3-2 Instruments and Tools

3.2.4 Unpacking the Base Station

Checking the Package Container

After the equipment arrives at the installation site, you should do the following check tasks:

- Check against the Packing List on the package container.
If any item is inconsistent with the Packing List, please contact us immediately.
- Check whether the package container is in good condition and not placed upside down during transportation.

If the package container is damaged seriously or soaked, please contact us immediately.



Note

Keep the package container, equipment and packing materials properly, and photograph them for reference.

After the above check tasks are completed, you can unpack the base station.

Unpacking the Wooden Case



Caution

- Avoid collision with the gate or wall while carrying the equipment.
- Never touch the parts or unpainted surfaces with sweat-soaked or dirty gloves.
- Carry the wooden case into or near the equipment room before unpacking. This can prevent the cabinet from being damaged.

Tools	Claw hammer, slot type screwdriver and wrench
--------------	---

To unpack the wooden case, do as follows:

Step 1 Wear the anti-static gloves.

Step 2 Lay the wooden case on the ground with the wooden frame facing downwards. See [Figure 3-1](#).

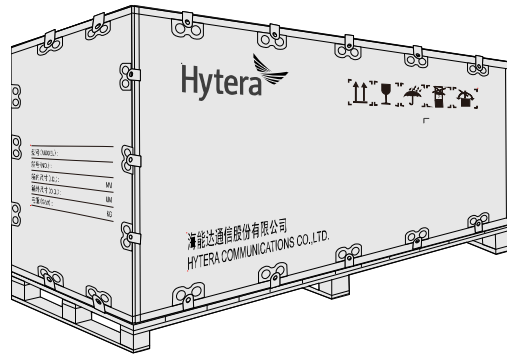

Figure 3-1 Laying the Wooden Case

Step 3 Pull the tongue piece on the wooden cover straight using the wench, claw hammer or screwdriver. See [Figure 3-2](#).

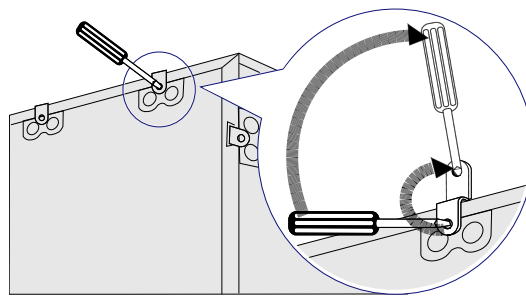

Figure 3-2 Pulling the Tongue Piece Straight

Step 4 Remove the cover (see the up arrow in [Figure 3-3](#)). If you see a cabinet, proceed to the next step directly. If you see a carton, take it out from the wooden case and unpack as instructed in “[Unpacking the Carton](#)” before the next step.

Step 5 Pull the tongue piece straight on the side wooden plate and remove the plate. See the right arrow in [Figure 3-3](#).

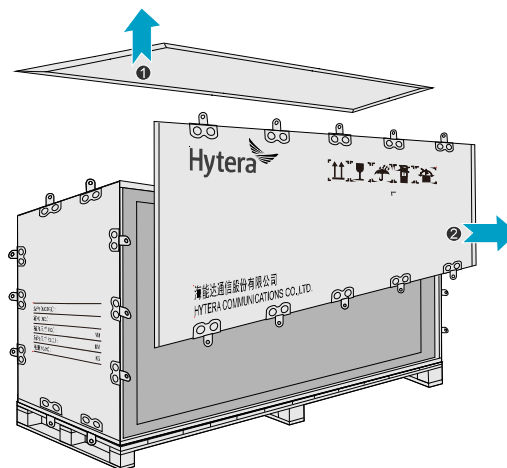

Figure 3-3 Removing the Wooden Cover and Side Wooden Plate

Step 6 Place the cabinet upright with the wheels facing downwards.

Unpacking the Carton

Tools	Paper knife
--------------	-------------

To unpack the carton, do as follows:

Step 1 Cut the strap along the seam of the carton cover using the paper knife. See [Figure 3-4](#).

Caution

Apply a moderate force, to avoid damage to the internal articles.

Step 2 Open the carton and take out the articles.

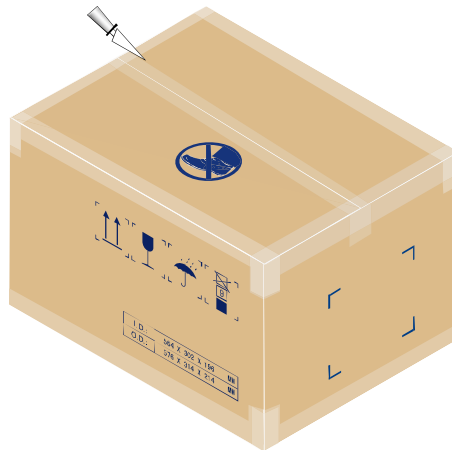

Figure 3-4 Unpacking the Carton

Checking the Articles

After unpacking the wooden case and carton, carefully check the received articles according to the Packing List.

You should perform the following check tasks:

- Checking the appearance
 - All articles shall be free from defects such as deformation or rupture.
 - The cabinet shall be firm.
 - The characters on the articles shall be clear.

- Checking the parts and accessories

The complete parts and accessories required for the hardware installation shall be contained in the package.

- Checking the internal units of the base station

Each kind of the internal unit shall comply with the Packing List in respect of the model and total number, and shall be free from defects such as break or looseness.

After check, the project supervisor and the client have to sign the Packing List together for confirmation.

3.3 Installation Location for the Internal Unit

For the installation locations for the internal units, see [Figure 3-5](#).

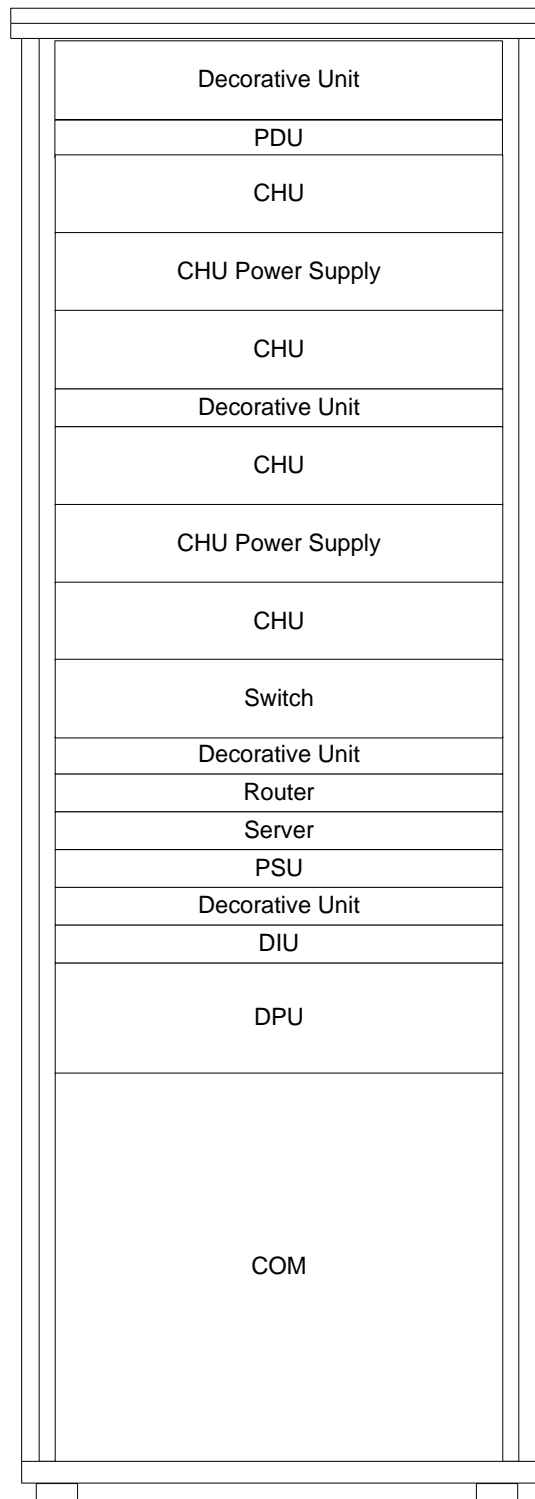

Figure 3-5 Installation Locations for Internal Units of 4-Carrier Base Station

3.4 Installation Flow

For the base station installation flow, see [Figure 3-6](#).

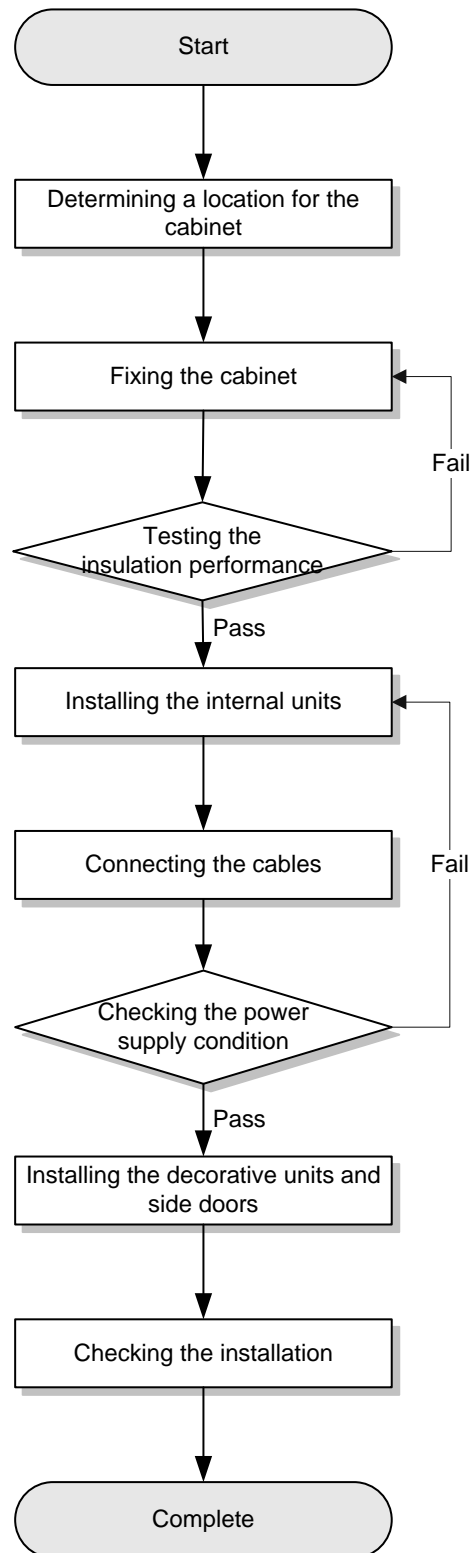
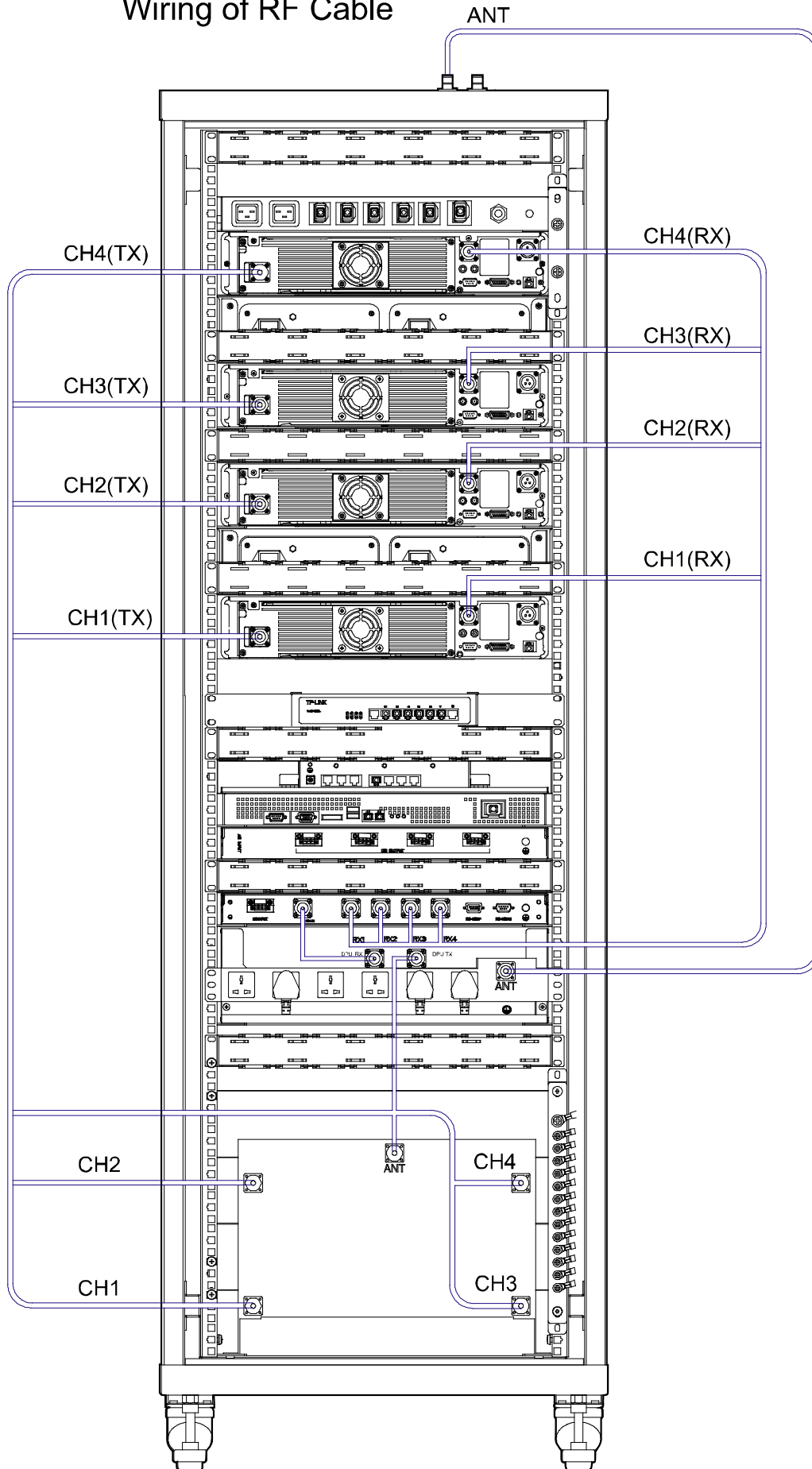

Figure 3-6 Installation Flow

3.5 Wiring Diagram

For the wiring diagram for the base station, see [Figure 3-7](#).

Wiring of RF Cable



Wiring of Signal Cable

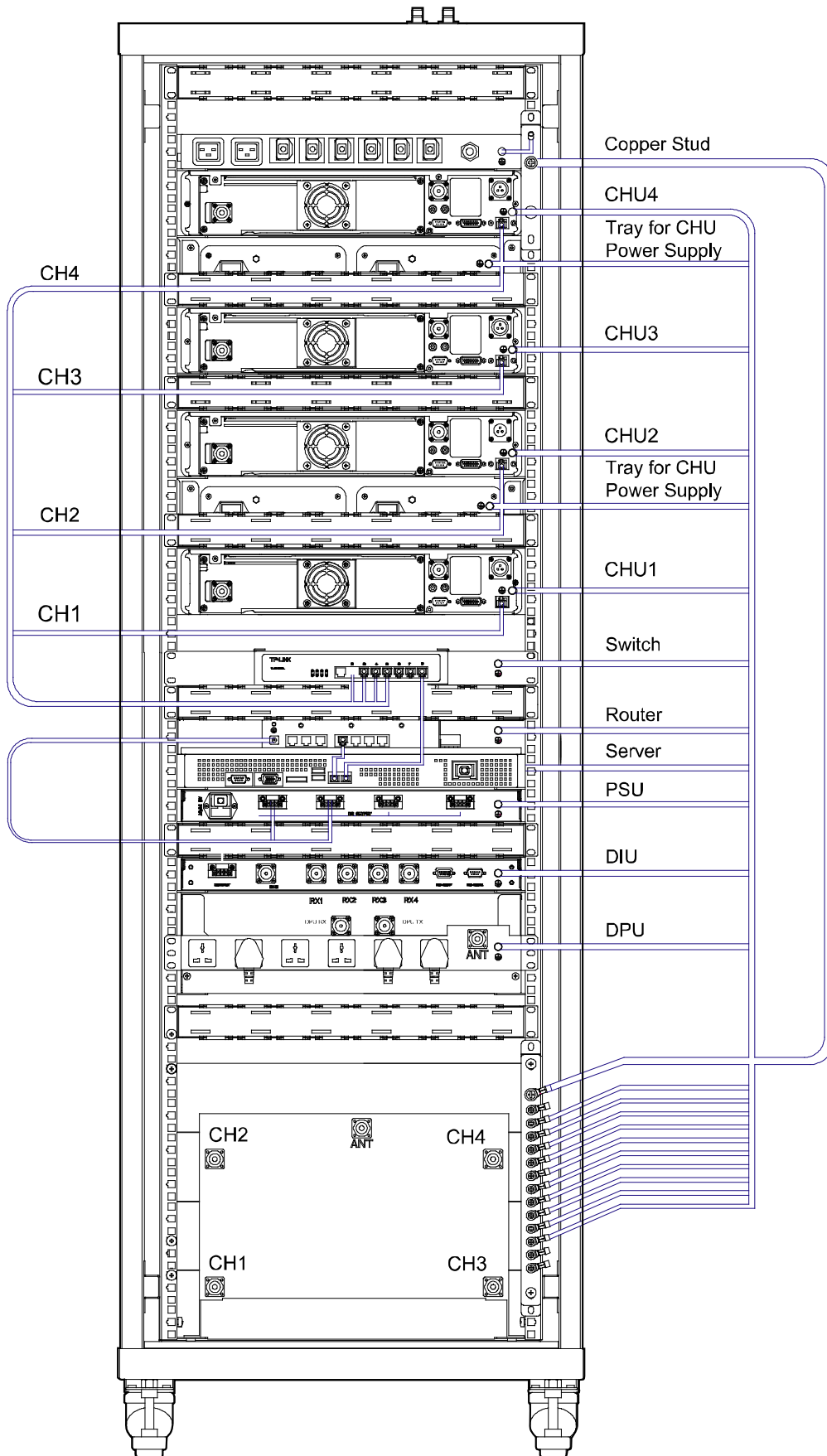

Wiring of Power Cord

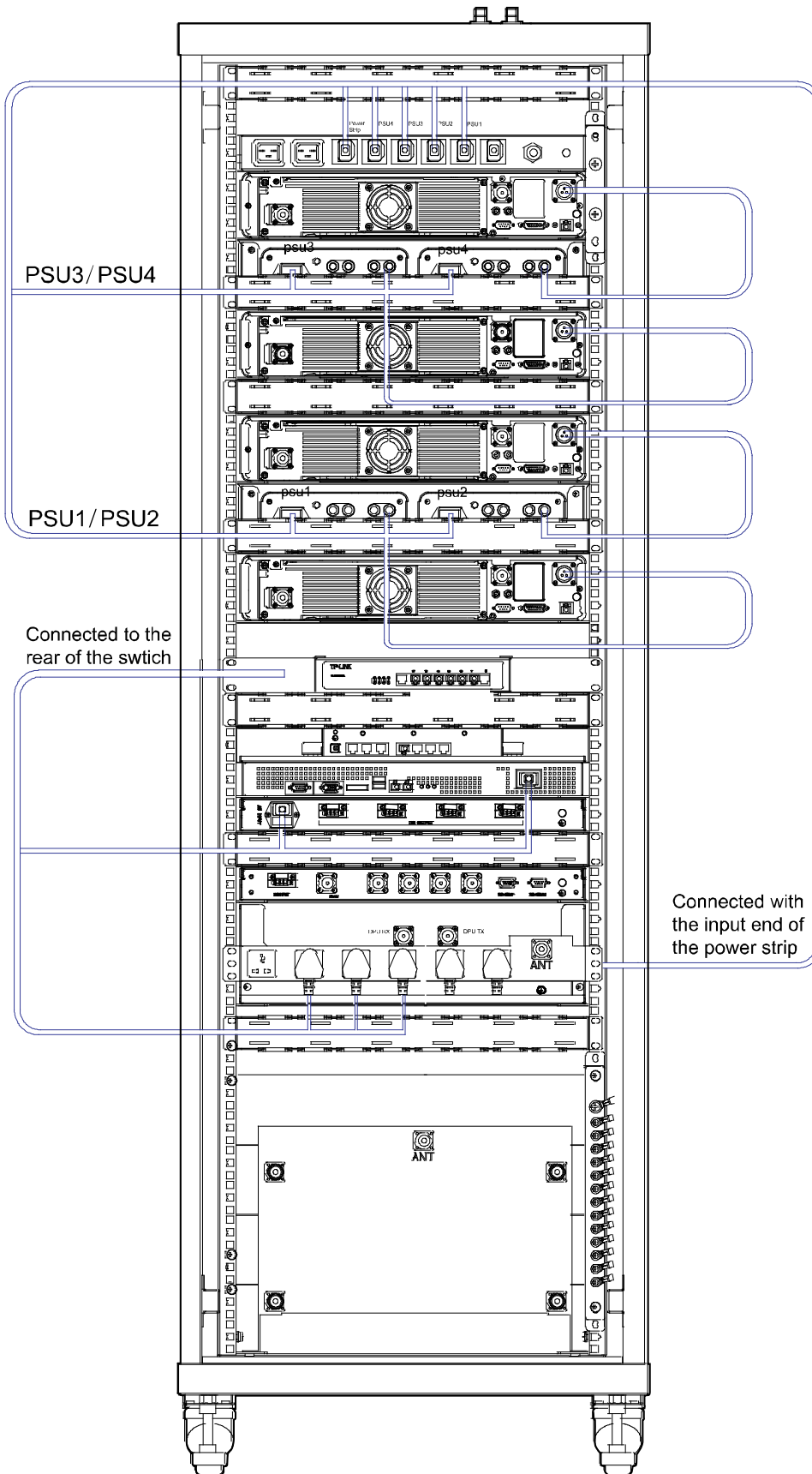

Figure 3-7 Wiring Diagram for 4-carrier Base Station

3.6 Installing the Cabinet

3.6.1 Determining a Location for the Cabinet

Determine a location for the cabinet as per the drawing. There shall be a clearance of at least 600mm before the front door and back door of the cabinet. See [Figure 3-8](#).

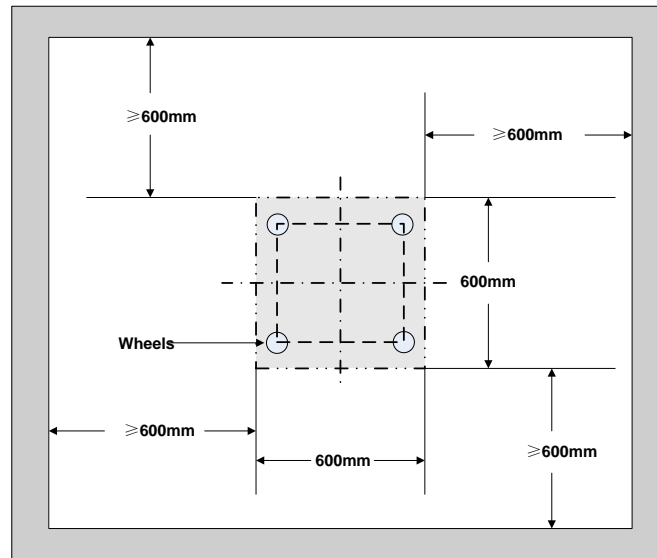

Figure 3-8 Installation Location for Base Station

3.6.2 Fixing the Cabinet

To fix the cabinet, do as follows:

Step 1 Push the cabinet to the location determined above, with its front side facing properly

Step 2 Fix the cabinet by tightening the four bolts at the bottom of the cabinet. See [Figure 3-9](#).

1. Loosen the upper nut by the wrench.
2. Loosen the lower nut by the wrench. And the cabinet will be lifted to an appropriate height automatically.
3. Tighten the upper nut.

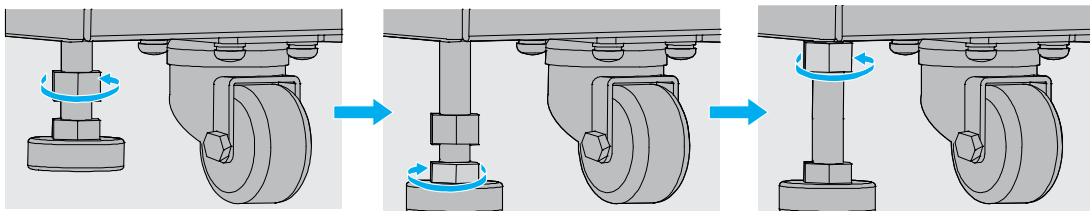

Figure 3-9 Fixing the Bolt

3.6.3 Testing the Insulation Performance

After the cabinet is fixed, test the insulation performance via the following steps:

Step 1 Toggle the multimeter to the “MΩ” position.

Step 2 Measure the resistance between the bolt and cabinet.

 **Note**

If the resistance is above 5MΩ, it means the cabinet is insulated properly; otherwise, check whether an insulation part is damaged or not mounted, and fix the cabinet again for testing the insulation performance.

3.7 Installing the Internal Units

3.7.1 Opening the Front Door and Back Door

Open the front door and back door of the cabinet. See [Figure 3-10](#).

Step 1 Unlock, and then remove the key from the keyhole in a vertical position.

Step 2 Press the **PUSH** button until the handle has bounced.

Step 3 Turn the handle counter-clockwise.

Step 4 Pull the handle outward and open the door.

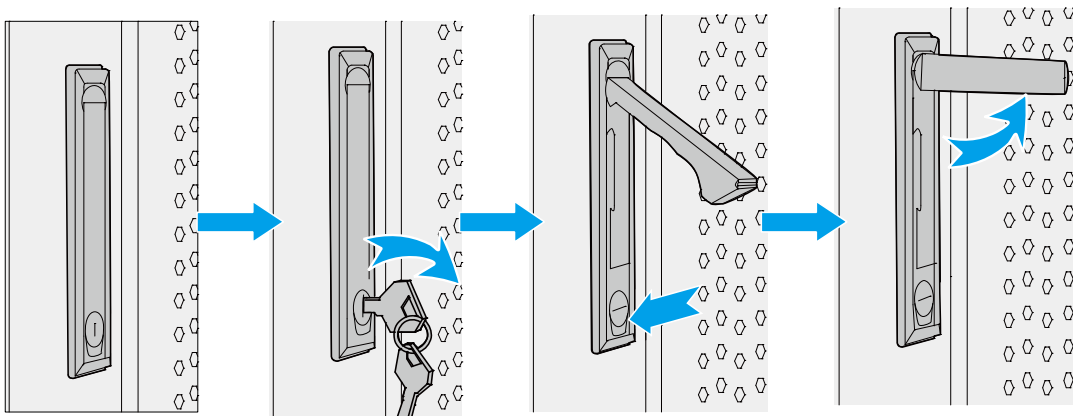

Figure 3-10 Opening the Front Door and Back Door

3.7.2 Removing the Side Door

Press the two latches downwards simultaneously and pull the side door outwards. See [Figure 3-11](#).

 **Caution**

Take care to avoid bodily injuries while removing the side door.

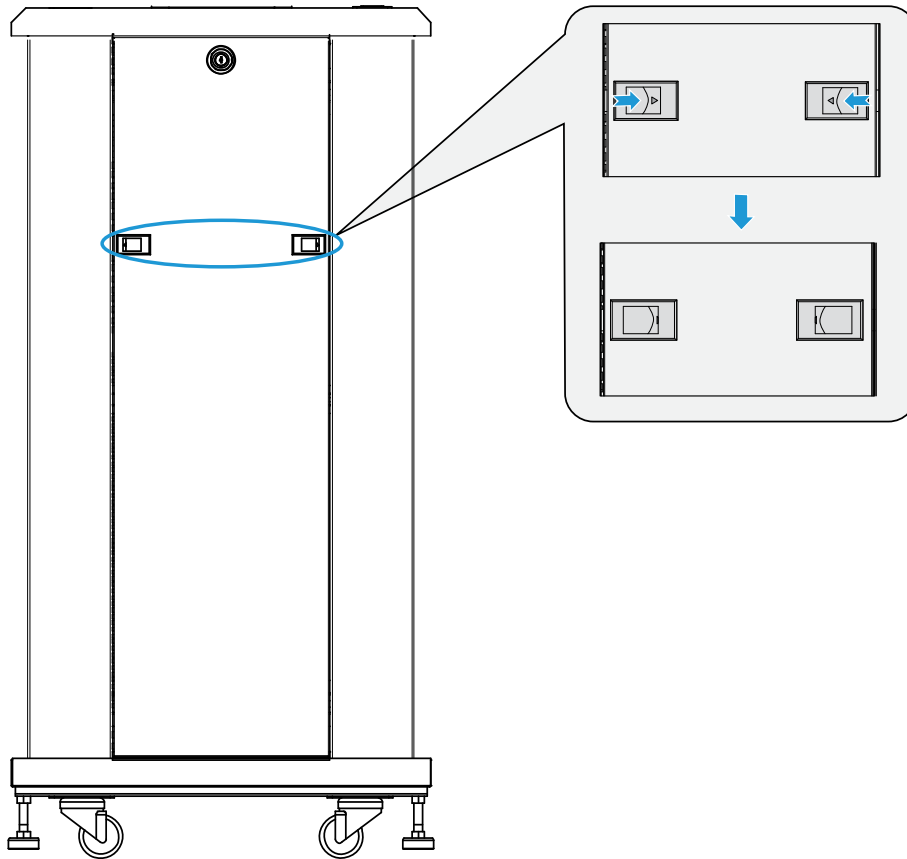

Figure 3-11 Removing the Side Door

3.7.3 Installing the Internal Units

Installing the CHU

The PDU, CHU, CHU power supply, switch, server, DIU and DPU can be installed similarly. The following section takes the CHU installation for example.

Step 1 Plan the installation locations for the internal units.

Plan the installation locations according to the scale on the cabinet and the height of the internal units, and install the floating nuts properly on upright column of the cabinet to fix the screw.

Step 2 Install the tray.

1. Place the tray at the planned location, and align its waist-shaped hole with the square hole in the upright column.
2. Tighten the screw to secure the tray. See [Figure 3-12](#).

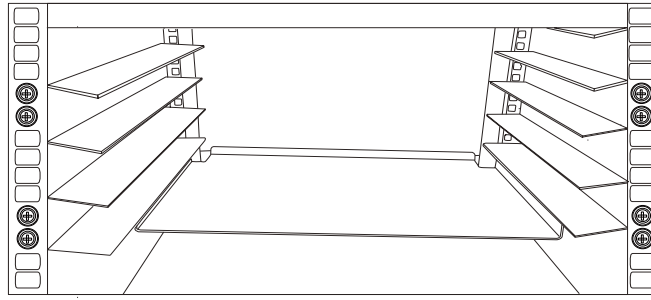

Figure 3-12 Installing the Tray

**Note**

As there are a wide variety of trays, here we only take two kinds of them for example

Step 3 Place the CHU on the tray, and push the tray until the waist-shaped holes on the front panel of the MTU fit the upright column. See [Figure 3-13](#).

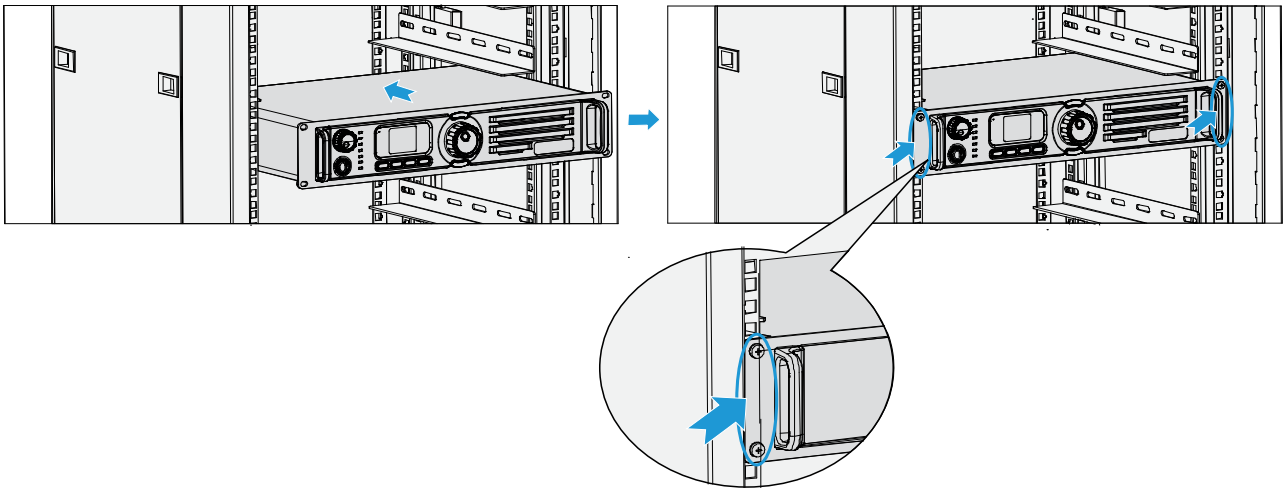

Figure 3-13 Installing the CHU

Step 4 Tighten the screws on the front panel.

Installing the Router

The router shall be installed from the back of the cabinet. See [Figure 3-14](#).

Step 1 Place the router in the right position, and align its ears with the square holes in the upright column.

Step 2 Tighten the screws to secure the router.

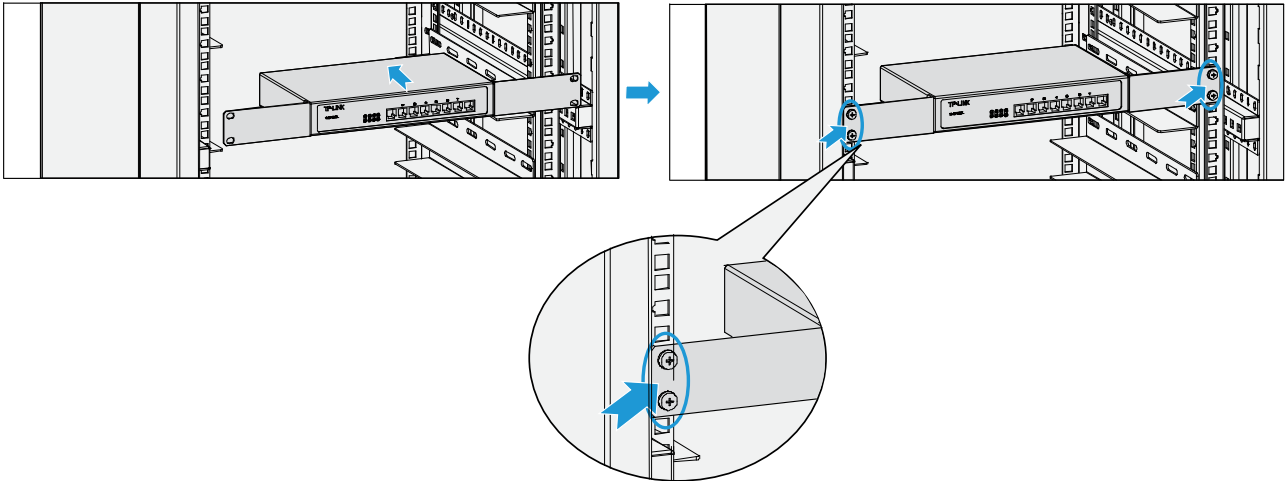

Figure 3-14 Installing the Router

Installing the COM

The COM shall be installed from the back of the cabinet. See [Figure 3-15](#).

Step 1 Place the COM on the holder, and slide it until the screw holes in the COM are aligned with those in the holder.

Step 2 Tighten the screws on the holder.

Caution

Take care to avoid bodily injuries while carrying the heavy COM.

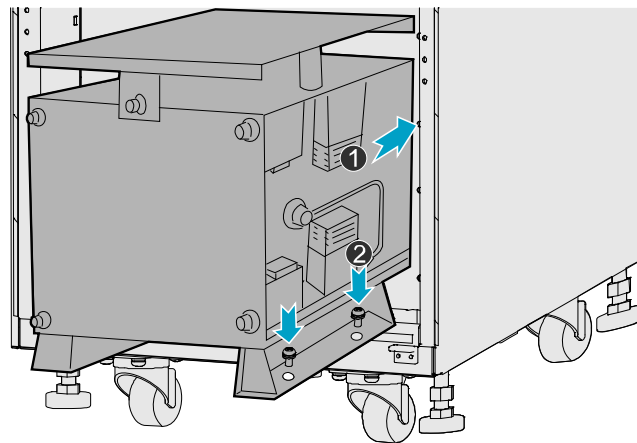

Figure 3-15 Installing the COM

3.7.4 Connecting the Internal Cables

Connect the internal cables properly according to the cable location and label. See [Figure 3-16](#).

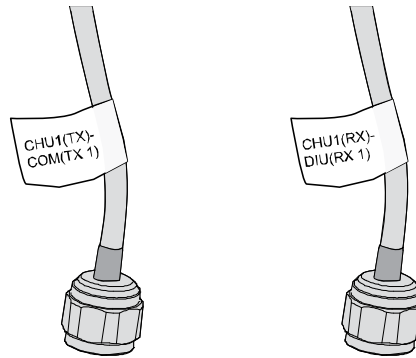

Figure 3-16 Outline of Cable

Note

In [Figure 3-16](#), the description “CHU1(TX)-COM(TX 1)” on the label tells you that the corresponding cable shall be connected between the TX interface of CHU1 and TX1 interface of the COM; while the description “CHU1(RX)-DIU(RX 1)” on the label tells you that the corresponding cable shall be connected between the RX interface of CHU1 and RX1 interface of the DIU.

3.7.5 Installing the Decorative Unit

After the power supply condition is checked (see [3.9.4 Checking the Power Supply Condition](#)), install the decorative unit in the empty frame. See [Figure 3-17](#).

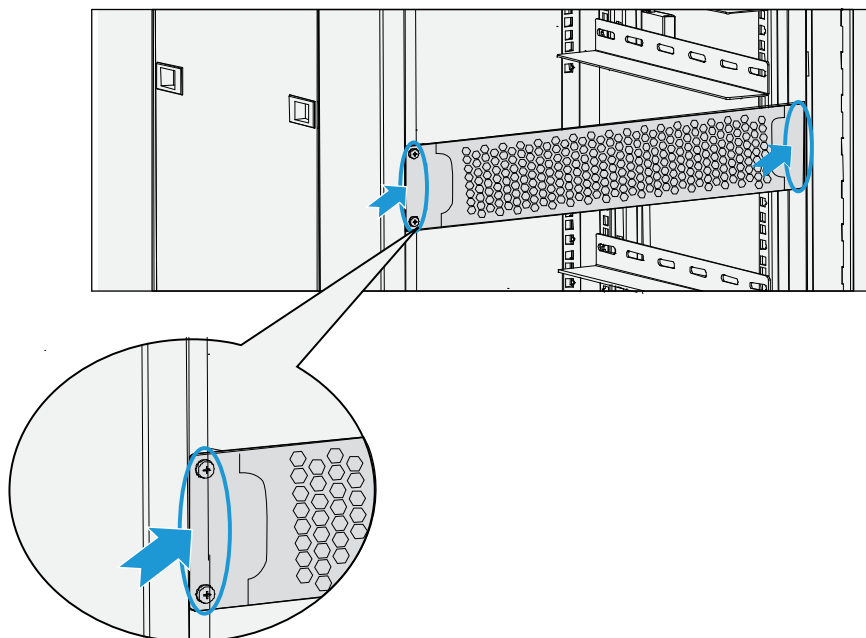

Figure 3-17 Installing the Decorative Unit

3.7.6 Installing the Side Door

Align the side door with the cabinet, and keep pressing it until the latches have bounced.

3.8 Connecting the External Cables

3.8.1 Requirements

The following requirements shall be met before connecting the external cables:

- The cabinet has been installed properly.
- All the internal units in the cabinet have been installed, and the **On/Off Switch** on all appropriate internal units is toggled to the “Off” position.

3.8.2 Cables to Be Connected

The external cables shall be connected to the interfaces in the EIB on the top of the cabinet. For details on the cables, see [Table 3-3](#).

Name	Color	Remark
Ground Cable	Yellowish green	6mm ² , 49-core, 450/750V, outer diameter: 8.1mm
AC Power Cord	Red, blue, yellowish green	6mm ² , 3pcs
RF Cable	Black	75Ω coaxial cable, 4pcs
RJ45 Adapter Cable	Grey	8-core, 100Ω twisted-pair cable, 3pcs
DB9 Adapter Cable	Grey	3-core, serial cable, 1pcs
RJ48 Adapter Cable	Grey	4-core, 120Ω twisted-pair cable, 1pcs

Table 3-3 Cables to Be Connected

3.9 Performing Post-installation Check

3.9.1 Requirements

The following requirements shall be met before you perform the post-installation check.

- The cabinet has been installed properly.
- All the internal units have been installed properly in the cabinet.
- The cables have been connected properly.
- All switches of the power distribution box are set to the “Off” position.

3.9.2 Checking the Cabinet

Check the cabinet according to [Table 3-4](#).

No.	Item
1	Check whether the location of the cabinet conforms to the drawing.

No.	Item
2	Check whether all the internal units are installed properly, and all cables in the cabinet are connected correctly.
3	Check whether the side doors are installed and the ground cable is connected properly.
4	Check whether all screws are tightened.
5	Check whether the cabinet is stable in its place and looks tidy.
6	Check whether the surface of the cabinet is clean and well painted, and no dust or other sundries exist in the cabinet.
7	Check whether the marks on the cabinet are correct and clear.
8	Check whether the disuse interfaces on the top of the cabinet are covered with the plastic dust caps.
9	Check whether all parts of the cabinet are in good condition.

Table 3-4 Checklist for the Cabinet

3.9.3 Checking the Cable

Check the cables according to [Table 3-5](#).

No.	Item
1	Check whether all cables are in good condition.
2	Check whether there are no joints on all cables.
3	Check whether the ground cable is excessive. If yes, please cut the excessive part off.
4	Check whether the power cord and ground cable are connected properly.
5	Check whether the bare wire and OT handle of the terminal is sealed with the insulation tape or heat shrinkable sleeve.
6	Check whether the power cord and ground cable are tied separately.
7	Check whether all cables are tied neatly and evenly, and whether the cable ties are facing the same direction and cut neatly.
8	Check whether the labels on the cables are clear and neat.

Table 3-5 Checklist for the Cable

3.9.4 Checking the Power Supply Condition

Caution

Before connecting the base station to the power supply, measure the resistance at all power connectors and ground connectors using the multimeter, and check whether the short circuit exists.

Check the power supply condition via the following steps:

- Step 1** Check whether the input voltage from the mains electricity satisfies the local requirements, and whether the live wire and null wire are connected correctly.
- Step 2** Toggle all power switches on the power strip to the “On” position.
- Step 3** Toggle the power switch on the CHU power supply to the “On” position.
- Step 4** Toggle the **On/Off Switch** to the “On” position.
- Step 5** Toggle the power switch on the PSU to the “On” position.
- Step 6** Toggle the power switch on the DIU to the “On” position.
- Step 7** Check the power supply condition for the internal units according to [Table 3-6](#).

Internal Unit	LED Indication for Normal Power Supply
CHU	The PWR indicator is on.
CHU Power Supply	The PWR indicator is on.
Switch	The PWR indicator is on.
Router	The PWR indicator is on.

Table 3-6 Checklist for Power Supply Condition

Note

If an internal unit does not give the normal power supply indication, connect the base station to the power supply again, or re-install the internal unit after disconnecting the power supply. If this problem still exists, please contact us.

3.9.5 Checking the Environment

Check the environment according to [Table 3-7](#).

No.	Item
1	Check whether the equipment room is clean and tidy.
2	Check whether there are cable ties and sundries in the wiring rack, at the bottom of the cabinet or around the cabinet.

No.	Item
3	Check whether there are cable ties and sundries on the floor of the equipment room.

Table 3-7 Checklist for Environment

4. Basic Operations

4.1 Powering up the Base Station

- Step 1** Connect the AC power supply.
- Step 2** Toggle all power switches on the power strip to the “On” position.
- Step 3** Toggle the power switch on the CHU power supply to the “On” position.
- Step 4** Toggle the **On/Off Switch** to the “On” position.
- Step 5** Toggle the power switch on the PSU to the “On” position.
- Step 6** Toggle the power switch on the DIU to the “On” position.

4.2 Powering off the Base Station

- Step 1** Toggle the power switch on the DIU to the “Off” position.
- Step 2** Toggle the power switch on the PSU to the “Off” position.
- Step 3** Toggle the **On/Off Switch** to the “Off” position.
- Step 4** Toggle the power switch on the CHU power supply to the “Off” position.
- Step 5** Toggle all power switches on the power strip to the “Off” position.
- Step 6** Disconnect the AC power supply.

5. Routine Maintenance

5.1 Purpose

The routine maintenance is to ensure stable and reliable operation of the device. It can help you to know the operation status of the device, so as to detect potential troubles and remove them on time.

The routine maintenance is performed for the following specific purposes:

- Remove all potential troubles to keep the system work properly.
- Ensure that all performance and service specifications can meet the related requirements.
- Ensure good collaboration within the entire system.
- Ensure that new devices or upgraded devices can access the system properly.□

5.2 Tasks

- Clean the equipment room regularly.
- Check the working status of the base station regularly. If an abnormal situation occurs, handle it in time.
- Clean the base station regularly.

A Abbreviations

Abbr.	Full Name
COM	Combiner
DIU	Divider Unit
DPU	Duplexer Unit
EMI	Electro Magnetic Interference
EMS	Electro Magnetic Susceptibility
GPS	Global Positioning System
MTBF	Mean Time between Failures
OIP3	Output 3 rd order Intercept Point
PDM	Power Distribution Module
PDU	Power Distribution Unit
PSU	Power Supply Unit
VGA	Video Graphics Array

FCC Warning:

Any Changes or modifications not expressly approved by the party responsible for compliance could void the user's authority to operate the equipment.

This device complies with part 15 of the FCC Rules. Operation is subject to the following two conditions: (1) This device may not cause harmful interference, and (2) this device must accept any interference received, including interference that may cause undesired operation.

This equipment complies with FCC radiation exposure limits set forth for an uncontrolled environment. This equipment should be installed and operated with minimum distance 2.5 m between the radiator & your body.

Industry Canada

This device complies with Industry Canada licence-exempt RSS standard (s). Operation is subject to the following two conditions: (1) this device may not cause interference, and (2) this device must accept any interference, including interference that may cause undesired operation of the device.

Le présent appareil est conforme aux CNR d'Industrie Canada applicables aux appareils radio exempts de licence.

L'exploitation est autorisée aux deux conditions suivantes:

(1) l'appareil ne doit pas produire de brouillage, et

(2) l'utilisateur de l'appareil doit accepter tout brouillage radioélectrique subi, même si le brouillage est susceptible d'en compromettre le fonctionnement.

The term "IC:" before the certification/registration number only signifies that the Industry Canada technical specifications were met.

Under Industry Canada regulations, this radio transmitter may only operate using an antenna of a type and maximum (or lesser) gain approved for the transmitter by Industry Canada. To reduce potential radio interference to other users, the antenna type and its gain should be so chosen that, the equivalent isotropically radiated power (e.i.r.p.) is not more than that necessary for successful communication.

Conformément à la réglementation d'Industrie Canada, le présent émetteur radio peut fonctionner avec une antenne d'un type et d'un gain maximal (ou inférieur) approuvé pour l'émetteur par Industrie Canada. Dans le but de réduire les risques de brouillage radioélectrique à l'intention des autres utilisateurs, il faut choisir le type d'antenne et son gain de sorte que la puissance isotrope rayonnée équivalente (p.i.r.e.) ne dépasse pas l'intensité nécessaire à l'établissement d'une communication satisfaisante.

This product meets the applicable Industry Canada technical specifications.

Le présent matériel est conforme aux spécifications techniques applicables d'Industrie Canada.

This Class A digital apparatus complies with Canadian ICES-003.

IC Radiation Exposure Statement:

This equipment complies with IC RF radiation exposure limits set forth for an uncontrolled environment. This transmitter must not be co-located or operating in conjunction with any other antenna or transmitter.

This equipment should be installed and operated with minimum distance 2.5m between the radiator & your body.