

# Preface



Thanks for your favor in our product. This manual is helpful for you to quickly know how to use the product. For detailed features and operations, please refer to the *Feature Description and Operation Manual* along with the product.

To avoid body injury or property loss caused by misoperation, please read the *Safety Information Booklet* carefully before use.

This manual is applicable to the following product:

[PD71XIS Digital Portable Radio \(X may represent 2, 5, 6 or 8\)](#)

## Icon Conventions

- : Indicates functions that are available on digital channel only.
- : Indicates functions that are available on analog channel only.

Functions marked with no icon are available on both analog and digital channels.

## Disclaimer

Hytera Communications Corporation Limited (the Company) endeavors to achieve the accuracy and completeness of this manual, but no warranty of accuracy or reliability is given. All the specifications and designs are subject to change without notice due to continuous technology development. No part of this manual may be copied, modified, translated, or distributed in any manner without the express written permission of us.

We do not guarantee, for any particular purpose, the accuracy, validity, timeliness, legitimacy or completeness of the Third Party products and contents involved in this manual.

If you have any suggestions or would like to learn more details, please visit our website at:

<http://www.hytera.com>.

## FCC Statement

This equipment has been tested and found to comply with the limits for a Class B digital device, pursuant to part 15 of FCC Rules. These limits are designed to provide reasonable protection against harmful interference in a residential installation. This equipment generates and can radiate radio frequency energy and, if not installed and used in accordance with the instructions, may cause harmful interference to radio communications. However, there is no guarantee that interference will not occur in a particular installation. If this equipment does cause harmful interference to radio or television reception, which can be determined by turning the equipment off and on, the user is encouraged to try to correct.

The interference by one or more of the following measures:

- Reorient or relocate the receiving antenna. Increase the separation between the equipment and receiver.
- Connect the equipment into an outlet on a circuit different from that to which the receiver is connected.

- Consult the dealer or an experienced radio/TV technician for help.

Operation is subject to the following two conditions: 1. This device may not cause harmful interference, and 2. This device must accept any interference received, including interference that may cause undesired operation.

Note: Changes or modifications to this unit not expressly approved by the party responsible for compliance could void the user's authority to operate the equipment.

## **Compliance with RF Exposure Standards**

Hytera's portable radio complies with the following RF energy exposure standards and guidelines:

- United States Federal Communications Commission, Code of Federal Regulations; 47 CFR § 1.1307, 1.1310 and 2.1093
- American National Standards Institute (ANSI) / Institute of Electrical and Electronic Engineers (IEEE) C95. 1:2005; Canada RSS102 Issue 5 March 2015.
- Institute of Electrical and Electronic Engineers (IEEE) C95.1:2005 Edition

## **RF Exposure Compliance and Control Guidelines and**

### **Operating Instructions**

To control your exposure and ensure compliance with the occupational/controlled environment exposure limits always adhere to the following procedures.

Guidelines:

- Do not remove the RF Exposure Label from the device.
- User awareness instructions should accompany device when transferred to other users.
- Do not use this device if the operational requirements described herein are not met.

Operating Instructions:

- Transmit no more than the rated duty factor of 50% of the time. To transmit (talk), push the Push-To-Talk (PTT) button. To receive calls, release the PTT button. Transmitting 50% of the time, or less, is important because this radio generates measurable RF energy exposure only when transmitting (in terms of measuring for standards compliance).
- Hold the radio in a vertical position in front of face with the microphone (and the other parts of the radio, including the antenna) at least one inch (2.5 cm) away from the nose. Keeping the radio at the proper distance is important because RF exposures decrease with distance from the antenna. Antenna should be kept away from eyes.
- When worn on the body, always place the radio in a Hytera's approved clip, holder, holster, case, or body harness for this product. Using approved body-worn accessories is important

because the use of Hytera's or other manufacturer's non-approved accessories may result in exposure levels, which exceed the FCC's occupational/controlled environment RF exposure limits.

- If you are not using a body-worn accessory and are not using the radio in the intended use position in front of the face, then ensure the antenna and the radio are kept at least 2.5 cm (one inch) from the body when transmitting. Keeping the radio at the proper distance is important because RF exposures decrease with increasing distance from the antenna.
- Use only manufacturer's name approved supplied or replacement antennas, batteries, and accessories. Use of non-manufacturer-name approved antennas, batteries, and accessories may exceed the FCC RF exposure guidelines.
- Contact your local dealer for the optional accessories of the product.

## **ISED Statement**

The device has been tested and compliance with SAR limits, users can obtain Canadian information on RF exposure and compliance

Après examen de ce matériel aux conformités aux limites DAS et/ou aux limites d'intensité de champ RF, les utilisateurs peuvent sur l'exposition aux radiofréquences et la conformité and compliance d'acquiescer les informations correspondantes

This device complies with Innovation, Science and Economic Development Canada RSS standard( Operation is subject to the following two conditions:

- (1) this device may not cause interference, and
- (2) this device must accept any interference, including interference that may cause undesired operation of the device.

Le présent appareil est conforme aux CNR d'ISED applicables aux appareils radio exempts de licence. L'exploitation est autorisée aux deux conditions suivantes: (1) l'appareil ne doit pas produire de brouillage, et (2) l'utilisateur de l'appareil doit accepter tout brouillage radioélectrique subi, même si le brouillage est susceptible d'en compromettre le fonctionnement

## **EU Regulatory Conformance**

As certified by the qualified laboratory, the product is in compliance with the essential requirements and other relevant provisions of the following directives:

- 1999/5/EC or 2014/53/EU
- 2006/66/EC
- 2011/65/EU
- 2012/19/EU

Please note that the above information is applicable to EU countries only.

# 1. Intrinsically Safe Radio Information

## Caution

- Observe the following safety instructions when using the product, so as to ensure safe and reliable operations. Failure to observe the instructions may result in danger or violation of applicable regulations.
- To avoid possible interference with blasting operations, always turn off the product when you are near electrical blasting caps, in a blasting area, or in areas posted "Turn off two-way radios". Obey all signs and instructions.

## 1.1 Product Marking

The intrinsically safety information of the product is as follows:

Certificate Number	Marking
IECEX FMG 13.0010X	Ex ia IIC T3 Ga Ex ia I T3 Ma Ex ia IIIC T160°C Da
FM13ATEX0023X	II 1 G Ex ia IIC T3 $-20^{\circ}\text{C} \leq \text{Ta} \leq +55^{\circ}\text{C}$ I M1 Ex ia I $-20^{\circ}\text{C} \leq \text{Ta} \leq +50^{\circ}\text{C}$ , IP5X II 1 G Ex ia IIC T3 $-20^{\circ}\text{C} \leq \text{Ta} \leq +50^{\circ}\text{C}$ , IP5X II 1 D Ex ia IIIC T160°C $-20^{\circ}\text{C} \leq \text{Ta} \leq +50^{\circ}\text{C}$ , IP5X
FM16US0013X	Class I Division 1, Groups A,B,C,D T3B $-20^{\circ}\text{C} \leq \text{Ta} \leq +55^{\circ}\text{C}$ Class I,II,III, Division 1, Groups A,B,C,D,E,F,G T3C $-20^{\circ}\text{C} \leq \text{Ta} \leq +50^{\circ}\text{C}$ , IP5X Class I, Zone 0, AEx ia IIC T3B $-20^{\circ}\text{C} \leq \text{Ta} \leq +55^{\circ}\text{C}$ Class I, Zone 0, AEx ia IIC T3C $-20^{\circ}\text{C} \leq \text{Ta} \leq +50^{\circ}\text{C}$ , IP5X Zone 20, AEx ia IIIC T160°C $-20^{\circ}\text{C} \leq \text{Ta} \leq +50^{\circ}\text{C}$ , IP5X
FM16CA0013X	Class I Division 1, Groups A,B,C,D T3B $-20^{\circ}\text{C} \leq \text{Ta} \leq +55^{\circ}\text{C}$ Class I,II,III Division 1, Groups A,B,C,D,E,F,G T3C $-20^{\circ}\text{C} \leq \text{Ta} \leq +50^{\circ}\text{C}$ , IP5X Zone 0, Ex ia IIC T3B Ga $-20^{\circ}\text{C} \leq \text{Ta} \leq +55^{\circ}\text{C}$ Class I, Zone 0, Ex ia IIC T3C Ga $-20^{\circ}\text{C} \leq \text{Ta} \leq +50^{\circ}\text{C}$ , IP5X

Certificate Number	Marking
	Zone 20, Ex ia IIIC T160°C Da $-20^{\circ}\text{C} \leq T_a \leq +50^{\circ}\text{C}$ , IP5X

The following describes the meaning of each part in the marking:

- Ex: specific marking for explosion protection.
- ia/ib: type of protection. It indicates that the product adopts intrinsic safety ia/ib suitable for use in zones 0, 1, and 2 (gases) and zones 20, 21, and 22 (dusts). For details about the zones, see [Hazardous Area Classification](#).
- I/II/III: equipment group. Group I indicates that the product is intended for use in mines susceptible to firedamp. Group II indicates that the product is intended for use in places with an explosive gas atmosphere other than mines susceptible to firedamp. Group III indicates that the product is intended for use in places with an explosive dust atmosphere.
- A/B/C/D/E/F/G: gas group. It defines the type of hazardous material in the surrounding atmosphere. Groups A, B, C, and D are for gases, while groups E, F, and G are for dusts and flyings.
- T3/T4: temperature class. T3 indicates that the maximum surface temperature during product use is  $200^{\circ}\text{C}$ . T4 indicates that the maximum surface temperature during product use is  $135^{\circ}\text{C}$ .
- T120°C/T160°C: It indicates that the maximum surface temperature during product use is  $120^{\circ}\text{C}$  or  $160^{\circ}\text{C}$ .

Ga/Ma/Da/Db: equipment protection level. It is the level of protection that is given to equipment based on the likelihood of its becoming a source of ignition and distinguishing the difference between explosive gas atmospheres, explosive dust atmospheres, and the explosive atmospheres in mines susceptible to firedamp.

- IP5X: ingress protection code. It indicates the degree of protection against solids and liquids.

## 1.2 Explosives Classification

- I: firedamp
- II: explosive mixture (vapors and mists)
- III: explosive dusts (fibers or flyings)

## 1.3 Hazardous Area Classification

Hazardous area is a potentially flammable or explosive area with flammable or explosive gases, vapors, or liquids or flammable dusts or fibers. Hazardous areas are classified into the following types:

Hazardous Substance	Present for Long Periods (1000 hours above per year)	Present in Normal Operation (10–1000 hours per year)	Present in Abnormal Operation (10 hours below per year)

Hazardous Substance	Present for Long Periods (1000 hours above per year)	Present in Normal Operation (10–1000 hours per year)	Present in Abnormal Operation (10 hours below per year)
Gases	Zone 0	Zone 1	Zone 2
Dusts	Zone 20	Zone 21	Zone 22

- Zone 0: a place in which an explosive atmosphere consisting of a mixture with air of dangerous substances in the form of gas, vapor or mist is present continuously or for long periods or frequently.
- Zone 1: a place in which an explosive atmosphere consisting of a mixture with air of dangerous substances in the form of gas, vapor or mist is likely to occur in normal operation occasionally.
- Zone 2: a place in which an explosive atmosphere consisting of a mixture with air of dangerous substances in the form of gas, vapor or mist is not likely to occur in normal operation but, if it does occur, will persist for a short period only.
- Zone 20: a place in which an explosive atmosphere in the form of a cloud of combustible dust in air is present continuously or for long periods or frequently.
- Zone 21: a place in which an explosive atmosphere in the form of a cloud of combustible dust in air is likely to occur in normal operation occasionally.
- Zone 22: a place in which an explosive atmosphere in the form of a cloud of combustible dust in air is not likely to occur in normal operation but, if it does occur, will persist for a short period only.

## 1.4 No Misoperations

Stop operating the product and leave the blasting area immediately when the intrinsic safety or integrity of the product is endangered, and deliver it to your local dealer for examination.

The safety or reliability of the product may be endangered when:

- The product is stored improperly.
- The product is faulty.
- The product works with overload.
- The product operates beyond the tolerance or threshold.
- The product is damaged during transportation.
- The product's housing is obviously damaged or cracked.
- The logo or characters on the product are hard to be recognized.

## 1.5 Safety Instructions

- Before using the product in a hazardous atmosphere, ensure that the two screws fixing the battery are correctly tightened.
- Ensure that the product is used only with the BL1813-Ex battery.
- Ensure that the product is used only with Hytera-specified accessories.
- Do not replace the battery or accessories in a hazardous atmosphere.
- Charge the battery using the designated charger in a non-hazardous atmosphere with a maximum ambient temperature of 40°C.
- Do not carry any standalone battery in a hazardous atmosphere.
- Do not use the product if its housing is damaged or cracked.
- Do not block or open the pressure adjustment hole on the product.
- Do not use a damaged antenna. A minor burn may be caused when you touch a damaged antenna.
- Do not expose the product to direct sunlight for a long time, nor place it close to a heating source.
- Do not disassemble or modify the product. Unauthorized modification may negate the approval rating of the product.
- Do not attempt to disassemble, destroy, or short-circuit the battery. Never dispose of it in fire.
- Hold the product upright and keep its microphone 2.5 to 5 centimeters away from your mouth during use.
- If you wear the product, ensure that its antenna is at least 2.5 centimeters away from your body during transmission.

## 1.6 Compliance Standards





Standard	Issue Date
IECEX	
IEC-60079-0 (Ed. 6.0)	2011
IEC-60079-11 (Ed. 6.0)	2011
FM	
CAN/CAS-C22.2 NO.60529(Ed. 5.0)	2005
CAN/CAS-C22.2 NO.0-M91	2006
CAN/CAS-C22.2 NO.61010-1(Ed. 3.0)	2012
CAN/CAS-C22.2 NO.213-M1987	2013

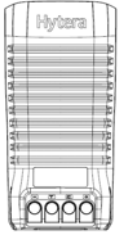
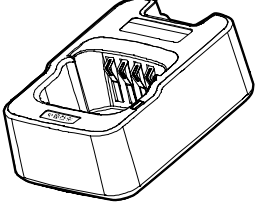
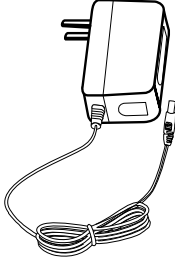

Standard	Issue Date
CAN/CAS-C22.2 NO.60079-11(Ed. 6.0)	2014
CAN/CAS-C22.2 NO.60079-0(Ed. 6.0)	2015
FM Class 3611	2004
FM Class 3810	2005
FM Class 3600	2011
FM Class 3640	2013
FM Class 3610	2015
ANSI/IEC 60529(Ed. 4.0)	2004
ANSI/ISA 60079-0(12.00.01) (Ed. 6.0)	2013
ANSI/ISA 60079-11(12.02.01) (Ed. 6.0)	2012
ANSI/ISA 61010-1(82.02.01) (Ed. 3.0)	2012
ATEX	
EN 60079-0	2012
EN 60079-11	2012

## 2. Items in the Package

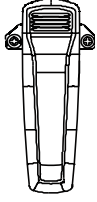
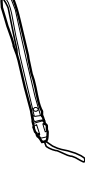
Please unpack carefully and check if all items listed below are received. If any item is missing or damaged, please contact your dealer.

		
<b>Radio</b>	<b>Battery</b>	<b>Charger</b>
		
<b>Power Adapter</b>	<b>Antenna</b>	<b>Belt Clip</b>
		
<b>Strap</b>	<b>Documentation Kit</b>	

### Note

- The pictures in this manual are for reference only.
- The frequency band is marked on the label of antenna; if it is unavailable there, see the label on the radio.

# 3. Product Overview

## 3.1 Product Controls

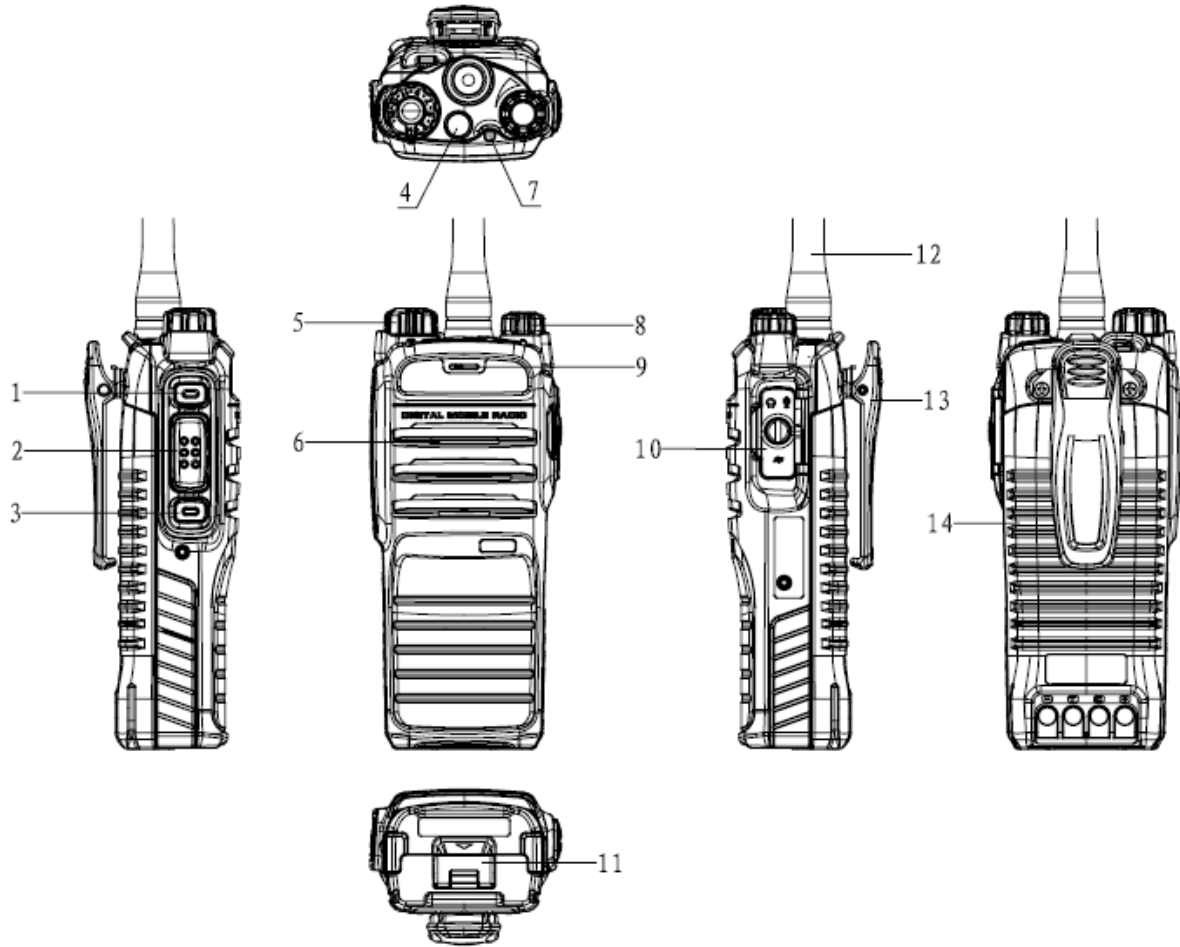

No.	Part Name	No.	Part Name
①	SK1 (Side Key 1)	⑧	Power On-Off/Volume Control Knob
②	PTT (Push-to-Talk) Key	⑨	Microphone
③	SK2 (Side Key 2)	⑩	Accessory Connector
④	TK (Top Key)	⑪	Battery Latch
⑤	Channel Selector Knob	⑫	Antenna
⑥	Speaker	⑬	Belt Clip
⑦	LED Indicator	⑭	Battery

## 3.2 Programmable Keys

For enhanced convenience, you may request your dealer to program the **SK1**, **SK2**, and **TK** () as shortcuts to certain functions. Please refer to the *Feature Description and Operation Manual* along with the product for more details.

 **Caution:** The **TK** key is programmed with emergency feature by default (short press: Emergency On; long press: Emergency Off). It is programmable by your dealer.

## 3.3 LED Indicator

LED Indication	Radio Status
The LED indicator flashes green.	Powering on
The LED indicator glows green.	Receiving
The LED indicator glows red.	Transmitting
The LED indicator flashes orange slowly.	Scanning or Roaming
The LED indicator flashes orange rapidly.	Emergency
The LED indicator glows orange.	Call hang time. No voice is being transmitted or received on the traffic channel during a call. Within such period, you can hold down the <b>PTT</b> key to talk to the other party.

## 4. Before Use

### 4.1 Attaching the Battery

**Step 1** Align the battery slots with the guide rails on the radio as ① shows, and push the battery as ② shows.

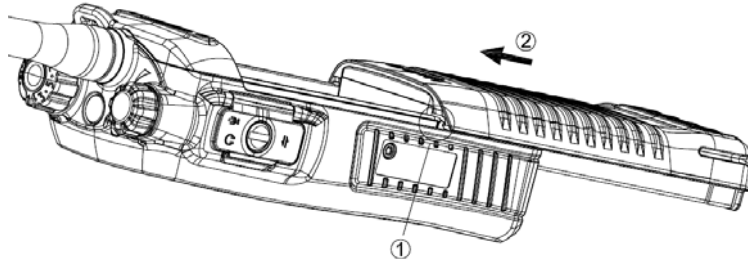

**Step 2** Open the battery latch and hold it down until the metal lock goes into the battery housing completely as ③ shows.

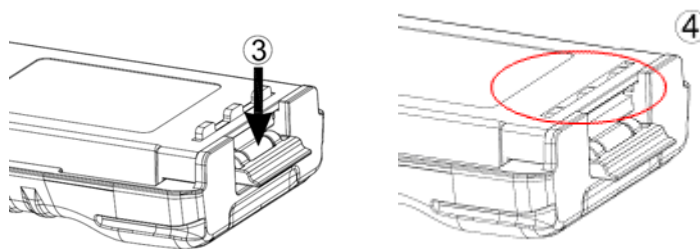

**Step 3** Push the battery until it is fully fitted into the slot, and then release the battery latch as ④ shows.

 **Note:** To remove the battery, please power off the radio first. Then open the battery latch, and slide the battery out while holding down the battery latch.

### 4.2 Attaching the Antenna

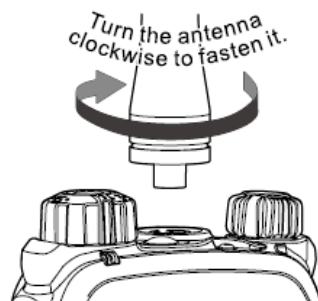

 **Caution:** Do not hold the radio by its antenna, otherwise the performance and lifespan of the antenna will be reduced.

## 4.3 Attaching the Belt Clip

**Step 1** Remove the screws.

**Step 2** Align the screw holes on the belt clip with those on the radio's back, and then tighten the screws.

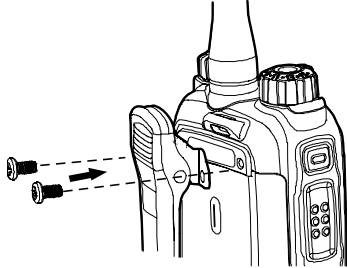

## 4.4 Attaching the Accessories

**Step 1** Open the accessory connector cover as shown below.

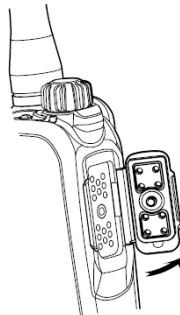

**Step 2** Align the accessory (such as an audio accessory, or a programming cable) plug with the accessory connector.

 **Caution:**

Do not scrape the silicone rubber surrounding the accessory connector screw hole, in order to ensure the waterproof performance of the radio.

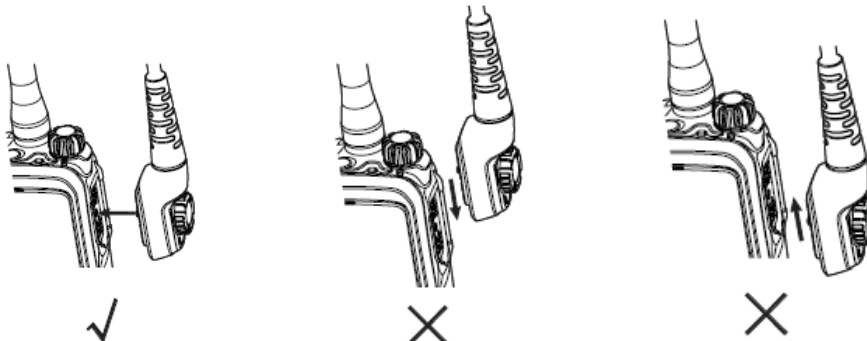

**Step 3** Tighten the screw on the plug.

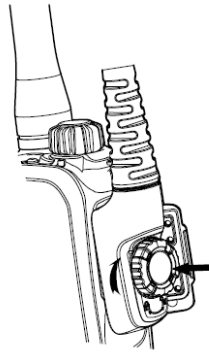

## 4.5 Charging the Battery

### Caution:

- Use the charger specified by the Company to charge the battery.
- Make sure the radio is powered off before charging. Read the *Safety Information Booklet* in advance to get necessary safety information.
- Charge a new battery for at least 5 hours before initial use for best performance.

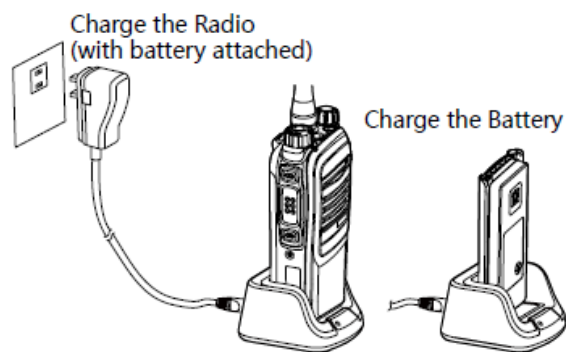

Charging Status Indication (on charger):

LED Indication	Charging Status
The LED Indicator flashes red slowly.	Standby (no load)
The LED Indicator glows red.	Charging
The LED indicator glows orange.	90% charged
The LED indicator glows green.	Fully charged
The LED Indicator flashes red	Charging failed

LED Indication	Charging Status
rapidly.	

## 4.6 Checking the Battery Power

You can check the current battery power by holding down the programmed **Battery Power Indicator** key preset by your dealer. And release the key to exit. Battery power indications and alert tone are listed below:

LED Indication/Tone	Battery Power
The LED Indicator glows green.	High
The LED Indicator glows orange.	Medium
The LED Indicator glows red.	Low
The LED Indicator glows red and an alert tone sounds.	The battery runs low. Please recharge or replace the battery for proper radio operation



## 5. Basic Operations

### 5.1 Turning the Radio On/Off

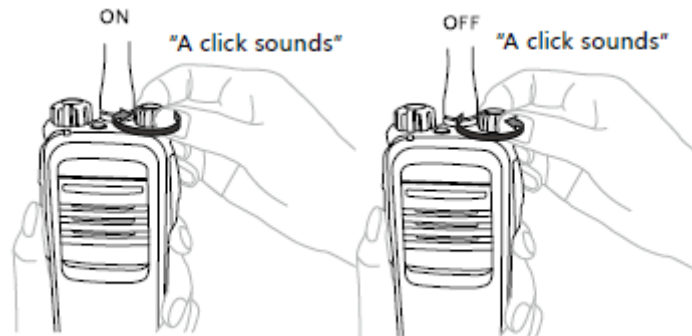

### 5.2 Adjusting the Volume

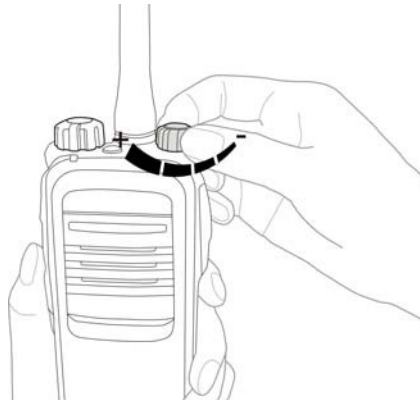

### 5.3 Selecting a Zone

A zone is a group of channels with the same property, which can facilitate convenient management over the channels. The radio supports 3 zones, each of which consists of up to 16 channels. Your dealer can program the zone for your specific needs. You can switch to the appropriate zone by pressing the programmed **Zone Up** or **Zone Down** key preset by your dealer.

## 5.4 Selecting a Channel

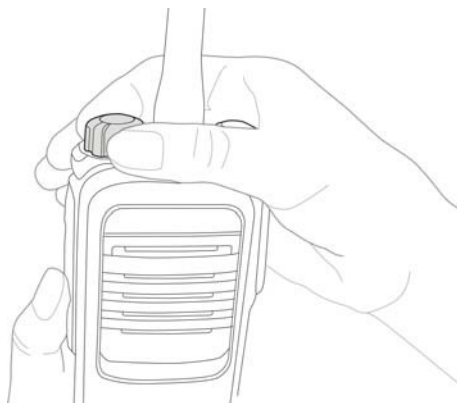

 **Note:** If the Channel Notify feature is enabled by your dealer, the radio will announce the channel number upon channel switching.

## 6. Call Services

After the radio is powered on, you can make and receive calls. To ensure optimal volume of the receiving radio, keep the microphone about 2.5 to 5 centimeters away from your mouth when the radio is transmitting.

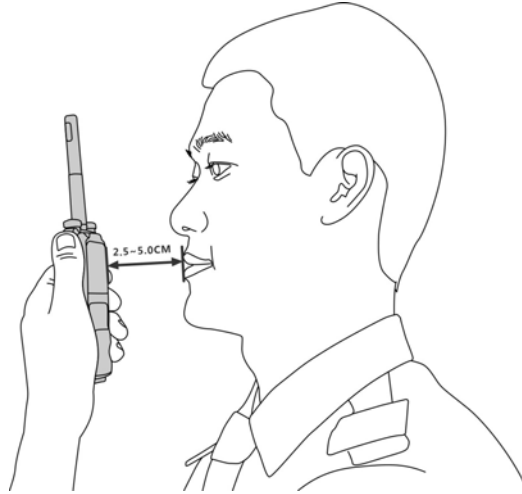

### 6.1 Private Call

#### 6.1.1 Initiating a Private Call

In the standby mode, hold down the **PTT** key to initiate a private call to the private contact preset for the current channel.

You may request your dealer to preset a regular private call contact for each digital channel.

#### 6.1.2 Receiving and Responding to a Private Call

When you receive a private call, you can listen to it without any operation and hold down the **PTT** key to call back within the preset time.

### 6.2 Group Call

#### 6.2.1 Initiating a Group Call

In the standby mode, hold down the **PTT** key to initiate a group call to the group contact preset for the current channel.

#### 6.2.2 Receiving and Responding to a Group Call

When you receive a group call, you can listen to it without any operation and hold down the **PTT** key to call back within the preset time.

## 6.3 Call on Analog Channel (No Signaling)

To transmit on an analog channel, hold down the **PTT** and speak into the microphone. To receive, release the **PTT** key.

Please refer to the *Feature Description and Operation Manual* along with the product for operation description on how to make and receive calls on the analog channel with signaling.

## 6.4 Emergency Call

In case of emergency, you can use Emergency Call to ask for help from your companion or the control center.

Emergency Call needs to be configured and enabled by your dealer. Please refer to the *Feature Description and Operation Manual* along with the product for details.

## 7. Available Features

Available features of this radio are listed below. Please refer to the *Feature Description and Operation Manual* for detailed feature descriptions.

Feature Type	Detailed Feature
Basic Setting	<ul style="list-style-type: none"> <li>● Indication: LED, Tone, Vibration</li> <li>● Audio: Mic AGC, Treble Boost, LQO, Audio Feedback Suppression</li> <li>● Scanning: Scan On, Scan Off, Scan List</li> <li>● Other Features: Power Level, VOX, One Touch Call, Renting, Programming, Covert Mode</li> </ul>
Digital Features	<ul style="list-style-type: none"> <li>● Voice Services: Group Call, Private Call, All Call,</li> <li>● Control Services: Alert Call, Radio Check, Remote Monitor, Radio Enable, Radio Disable, Priority Interrupt, Time-out Timer (TOT)</li> <li>● Personal Security Services: Emergency Alarm, Man Down, Lone Worker</li> <li>● Encrypt</li> <li>● Network: Talk Around, Roam</li> <li>● Other Features: Pseudo Trunking</li> </ul>
Analog Features	<ul style="list-style-type: none"> <li>● Voice Services: Call without Signaling, Call with Signaling,</li> <li>● Control Services: Compandor, Time-out Timer (TOT), Monitor, Squelch Off, Squelch Level Adjustment, CTCSS/CDCSS</li> <li>● Personal Security Services: Emergency Alarm, Man Down, Lone Worker</li> <li>● Scrambler</li> <li>● Talk Around</li> </ul>
API Features	<ul style="list-style-type: none"> <li>● GPS Report</li> <li>● Radio Registration Service</li> <li>● Telemetry</li> </ul>

## 8. Troubleshooting

Phenomena	Analysis	Solution
The radio cannot be powered on.	The battery may be improperly installed.	Remove the battery and then reattach it.
	The battery power may run out.	Recharge or replace the battery.
	The battery may suffer from poor contact caused by dirtied or damaged battery contacts.	Clean the battery contacts.
During receiving, the voice is weak, discontinuous or totally inactive.	The battery voltage may be low.	Recharge or replace the battery.
	The volume level may be low.	Increase the volume by rotating the <b>Volume Control</b> knob.
	The antenna may get loose or may be improperly installed.	Turn off the radio and reattach the antenna.
	The speaker may be blocked or damaged.	Clean the surface of the speaker.
You cannot communicate with other members.	The frequency or signaling may be inconsistent with that of other members.	Set your TX/RX frequency and signaling to the same as that of other members.
	The channel type (digital and analog) may be set inconsistently.	Make sure all members are on the same digital or analog channel.
	You may be too far away from the group members.	Move towards other members.
Irrelevant communication or noise is heard on the channel.	You may be interrupted by radios using the same frequency.	Change the frequency, or adjust the squelch level.
	The radio may be set with no signaling.	Set signaling for all member radios to avoid interference at the same frequency.
The noise is too	You may be too far away from	Move towards other members.

Phenomena	Analysis	Solution
loud.	other members.	
	You may locate in an unfavorable position. For example, your communication may be blocked by high buildings or frustrated in the underground areas.	Move to an open and flat area, and restart the radio to try again.
	You may suffer from external disturbance (such as electromagnetic interference).	Stay away from equipment that may cause interference.

If the above solutions cannot fix your problems, or you may have some other queries, please contact us or your local dealer for more technical support.

## 9. Care and Cleaning

To guarantee optimal performance as well as a long service life of the product, please follow the tips below.

### Product Care

- Do not pierce or scrape the product.
- Keep the product far away from substances that can corrode the circuit.
- Do not hold the product by its antenna or earpiece cable directly.
- Attach the accessory connector cover when the accessory is not in use.

### Product Cleaning



**Caution:** Turn off the product and remove the battery before cleaning.

- Clean up the dust and fine particles on the product surface and charging piece with a clean and dry lint-free cloth or a brush regularly.
- Use neutral cleanser and a non-woven fabric to clean the keys, control knobs and front case after long-time use. Do not use chemical preparations such as stain removers, alcohol, sprays or oil preparations, so as to avoid surface case damage.
- Make sure the product is completely dry before use.



## 10. Optional Accessories

Contact your local dealer for the optional accessories of the product.

 **Caution:** Use the accessories specified by the Company only; otherwise, the Company shall not be liable for any loss or damage arising out of use of unauthorized accessories.

# 11. Specifications

Item	Specifications
Frequency Range	136–174 MHz
Channel Spacing	12.5 kHz
Operating Voltage	7.4 VDC
Weight (with standard antenna & battery)	495 g
Sensitivity	0.3 $\mu$ V
RF Power Output	1 W / 0.5W
Rated Audio Power Output	0.5 W
Audio Distortion	$\leq$ 3%
Operating Temperature	–30°C to +60°C (non-hazardous environment)
	–20°C to +50°C* (hazardous environment)
Storage Temperature	–40°C to +85°C
Charging Temperature	0°C to +40°C
Battery	Ex-battery BL1813-Ex (1800 mAh)
Battery Life	About 14 hours (5-5-90 duty cycle)
Charging Time	About 4 hours
Maximum Charging Voltage	12 VDC

**\* 50°C: The operating temperature may vary. In an explosive gas atmosphere, it can reach up to 55°C. For details, see section 1.1 Product Marking.**