

Preface

Thanks for your favor in our product. To derive optimum performance from the product, please read this manual, the corresponding *TETRA Terminal Series Feature Book* and the *Safety Information Booklet* carefully before use.

This manual is applicable to the following product:

[PT560H F4 TETRA Portable Terminal](#)

Copyright Information

Hytera is the trademark or registered trademark of Hytera Communications Corporation Limited (the Company) in PRC and/or other countries or areas. The Company retains the ownership of its trademarks and product names. All other trademarks and/or product names that may be used in this manual are properties of their respective owners.

Disclaimer

The Company endeavors to achieve the accuracy and completeness of this manual, but no warranty of accuracy or reliability is given. All the specifications and designs are subject to change without notice due to continuous technology development. No part of this manual may be copied, modified, translated, or distributed in any manner without the express written permission of the Company.

We do not guarantee, for any particular purpose, the accuracy, validity, timeliness, legitimacy or completeness of the Third Party products and contents involved in this manual.

If you have any suggestions or would like to learn more details, please visit our website at:

<http://www.hytera.com>.

FCC Regulations

Federal Communication Commission (FCC) requires that all radio communication products should meet the requirements set forth in the above standards before they can be marketed in the U.S, and the manufacturer shall post a RF label on the product to inform users of operational instructions, so as to enhance their occupational health against exposure to RF energy.

Operational Instructions and Training Guidelines

To ensure optimal performance and compliance with the occupational/controlled environment RF energy exposure limits in the above standards and guidelines, users should transmit no more than 50% of the time and always adhere to the following procedures:

Your terminal radiates measurable RF energy only when it is transmitting, not when it is receiving or in standby mode.

Warning! : The PT560H F4 portable radio generates RF electromagnetic energy during transmit mode. This radio is designed for and classified as “Occupational Use Only,” meaning it must be used only during the course of employment by individuals aware of the hazards and the ways to minimize such hazards. This radio is NOT intended for use by the “General Population” in an uncontrolled environment.

EU Regulatory Conformance







As certified by the qualified laboratory, the product is in compliance with the essential requirements and other relevant provisions of the Directive 1999/5/EC. Please note that the above information is applicable to EU countries only.

Contents

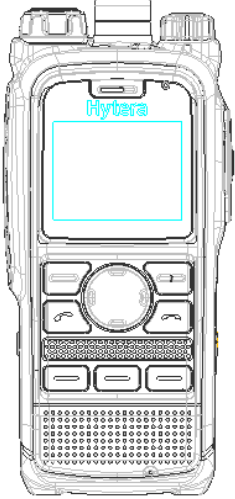
Preface	1
Copyright Information	2
Disclaimer	2
FCC Regulations	2
EU Regulatory Conformance	3
1. Items in the Package	6
2. Product Overview	7
2.1 Product Controls.....	7
2.2 LCD Icon.....	8
2.3 LED Indicator.....	10
3. Before Use	11
3.1 Attaching the Antenna	11
3.2 Attaching the Battery	11
3.3 Installing the SIM Card	11
3.4 Attaching the Belt Clip	12
3.5 Attaching the Accessories	12
3.6 Charging the Battery.....	13
4. Basic Operations	15
4.1 Turning On/Off the Terminal.....	15
4.2 Switching Operation Mode	15
4.3 Adjusting the Call Volume	15
4.4 Selecting a Group.....	15
4.5 Managing the PhoneBook	15
5. TMO Service	16
5.1 Individual Call	16
5.2 Group Call.....	17
5.3 PABX/PSTN Call	17
5.4 Emergency Call	17
5.5 Message Service	18
6. DMO Service	19
6.1 Individual Call	19
6.2 Group Call.....	19
6.3 Emergency Call	19
6.4 Message Service	20
7. Troubleshooting	21
8. Care and Cleaning	23
9. Optional Accessories	24

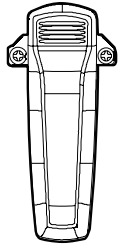
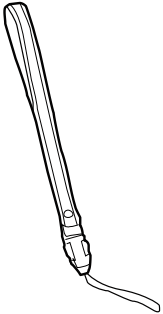
1. Items in the Package

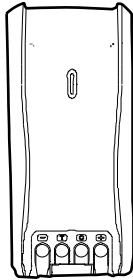
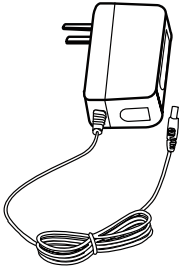
Please unpack carefully and check if all items listed below are received. If any item is missing or damaged, please contact your dealer.

		
Terminal	Antenna	Belt Clip
		
Strap	Charger	Battery
		
Power Adapter	Documentation Kit	

Note

The frequency band is marked on the label of antenna; if not, please refer to the label on the terminal for frequency band information.

2. Product Overview

2.1 Product Controls

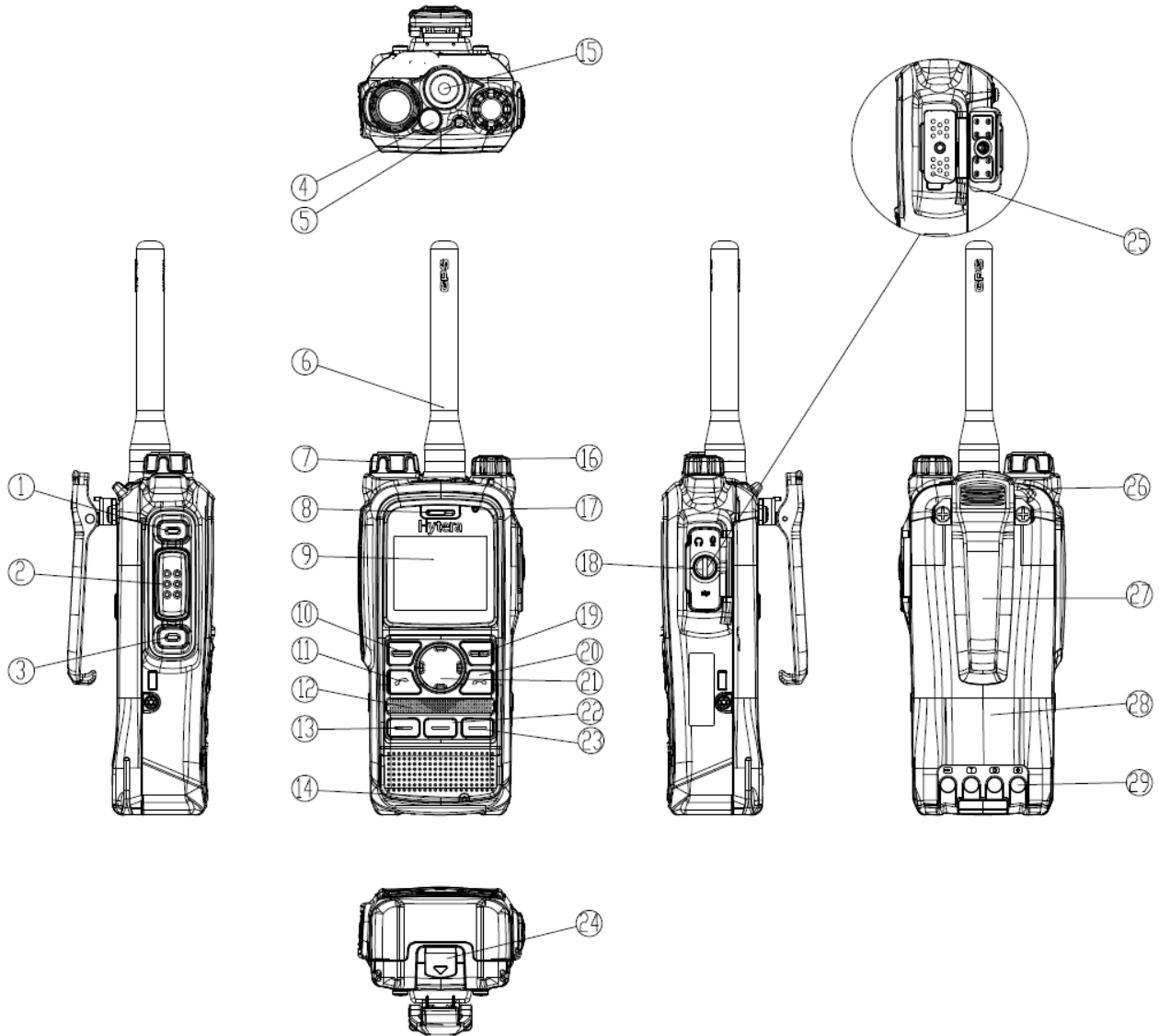







No.	Part Name	No.	Part Name
1	SK1 (Side Key 1)	15	Antenna Connector
2	PTT (Push-to-Talk) Key	16	Power On-Off/Volume Control Knob
3	SK2 (Side Key 2)	17	Half-duplex Microphone
4	Emergency Key	18	Accessory Connector Cover
5	LED Indicator	19	Options/Back Key



























No.	Part Name	No.	Part Name
6	Antenna	20	End Key
7	Group Selector Knob	21	Navigation Key
8	Full-duplex Receiver	22	F2Key
9	LCD Display	23	F3 Key
10	Func/OK Key	24	Battery Latch
11	Answer/Call Key	25	Accessory Connector
12	Half-duplex Speaker	26	Strap Hole
13	F1 Key	27	Belt Clip
14	Full-duplex Microphone	28	Battery
		29	Charging Piece













Note

For enhanced convenience, navigation keys, **Call** key, **OK** key, **Back** key, **SK1** and **SK2** key, **F1**Key, **F2**Key and **F3**Key as shortcuts to certain features. For the detailed introduction, please refer to the corresponding *TETRA Terminal Series Feature Book*.

2.2 LCD Icon

Icon	Terminal Status
	The terminal is not registered with the system (applicable for TMO only).
	The terminal is registered with the system, and more bars indicate stronger signal strength.
	The terminal is not registered with the system while the WAP browser is running.
	The terminal is registered with the system while the WAP browser is running, and more bars indicate stronger signal strength.
	There is(are) unread message(s).
	The Inbox is full.
	The terminal is operating in TMO.

Icon	Terminal Status
	The terminal is operating in DMO.
	The terminal is operating in fallback mode.
	The scan feature is enabled in TMO.
	The scan feature is enabled in fallback mode.
	The terminal is operating in silent mode.
	The terminal is operating in normal (ring and vibration) mode.
	The terminal is operating in vibration mode.
	An audio accessory is connected.
	An audio accessory is connected but not available for use.
	A palm microphone with keypad is connected.
	The GPS feature is active, and valid GPS or GLONASS data is received.
	The GPS feature is active, but no valid GPS or GLONASS data is received.
	A wireless accessory is connected and available for use.
	The BT feature is enabled but no wireless accessory is connected.
	A wireless accessory is connected but not available for use.
	A call is in progress.
	The terminal is selecting a group.
	A gateway device is available and connected in DMO.
	A gateway device is available but not connected in DMO.
	A repeater is available and connected in DMO.
	A repeater is available but not connected in DMO.
	The keypad is locked.
	The SIM card E2EE is in use.
	The microphone is disabled.
	AIE (Air Interface Encryption) is in use.
	E2EE (End-to-End Encryption) is in use.

Icon	Terminal Status
	Both AIE and E2EE are in use.
	The ongoing call enjoys a pre-emptive priority.
	The ongoing call enjoys a higher priority.
	The ongoing call enjoys a lower priority.
	The terminal is prohibited from transmitting.
	A call via gateway is in progress.
	An E2EE call via gateway is in progress.
	A call via repeater is in progress.
	An E2EE call via repeater is in progress.
	An AIE call via repeater is in progress.
	The AIE and E2EE call via repeater is in progress.
	An Emergency call is in progress.
	A broadcast call is in progress.

2.3 LED Indicator

LED Indication	Terminal Status
Glows red	Transmitting
Flashes red slowly	Low battery voltage Please replace or recharge the battery
Glows green	Receiving
Flashes green slowly	Channel idle in DMO
Glows orange	<ul style="list-style-type: none"> ● Channel busy in DMO ● The terminal is prohibited from transmitting.
Flashes orange slowly	The BS with which the terminal is registered is out of service in TMO.

3. Before Use

3.1 Attaching the Antenna



Do not hold the terminal by its antenna, otherwise the performance and lifespan of the antenna will be reduced.

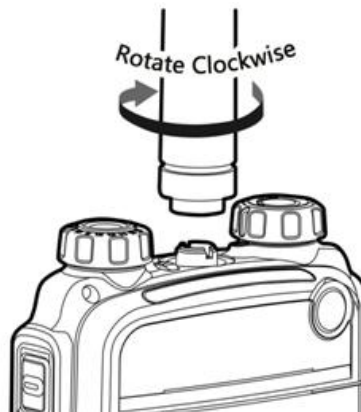

3.2 Attaching the Battery

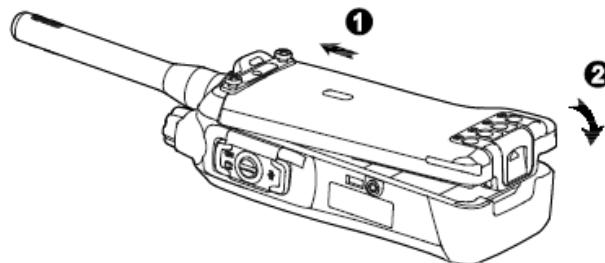

To remove the battery, turn off the terminal first. Then lift the battery latch and remove the battery.

3.3 Installing the SIM Card

If you have purchased the End-to-End Encryption (E2EE) feature which is realized via a SIM card, please buy a SIM card and install it first.

Step 1 Remove the battery.

Step 2 Loosen the screw fixing the SIM card cover, open the cover, and then place the card into the slot properly, as shown in the figure below.

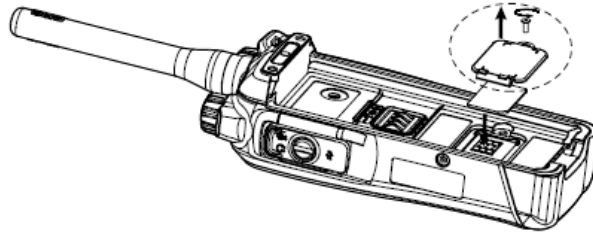

Step 3 Replace the cover and tighten the screw as shown in the figure below.

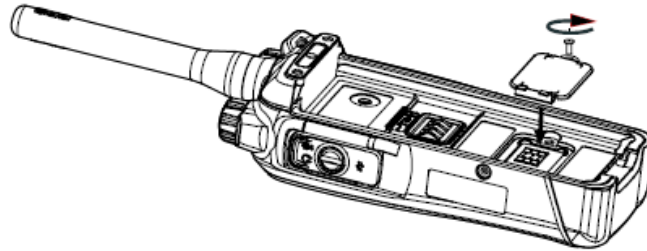

3.4 Attaching the Belt Clip

Step 1 Remove the two screws on the back of the terminal.

Step 2 Align the screw holes on the belt clip with those on the terminal, and then tighten the screws, as shown in the figure below.

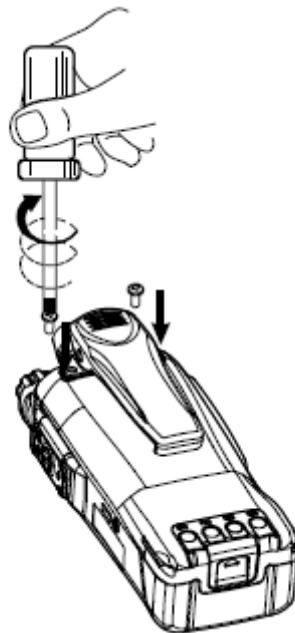

3.5 Attaching the Accessories

Step 1 Loosen the screw on the accessory connector cover, and open the cover as the arrow shows in the figure below.



Step 2 Align the accessory (such as audio accessory and programming cable) plug with the accessory connector.

Step 3 Secure the screw of the accessory.

3.6 Charging the Battery

Caution

- Use the charger specified by the Company to charge the battery.
- Make sure the terminal is powered off before charging. Read the *Safety Information Booklet* in advance to get necessary safety information.
- Charge a new battery for at least 5 hours before initial use for best performance.

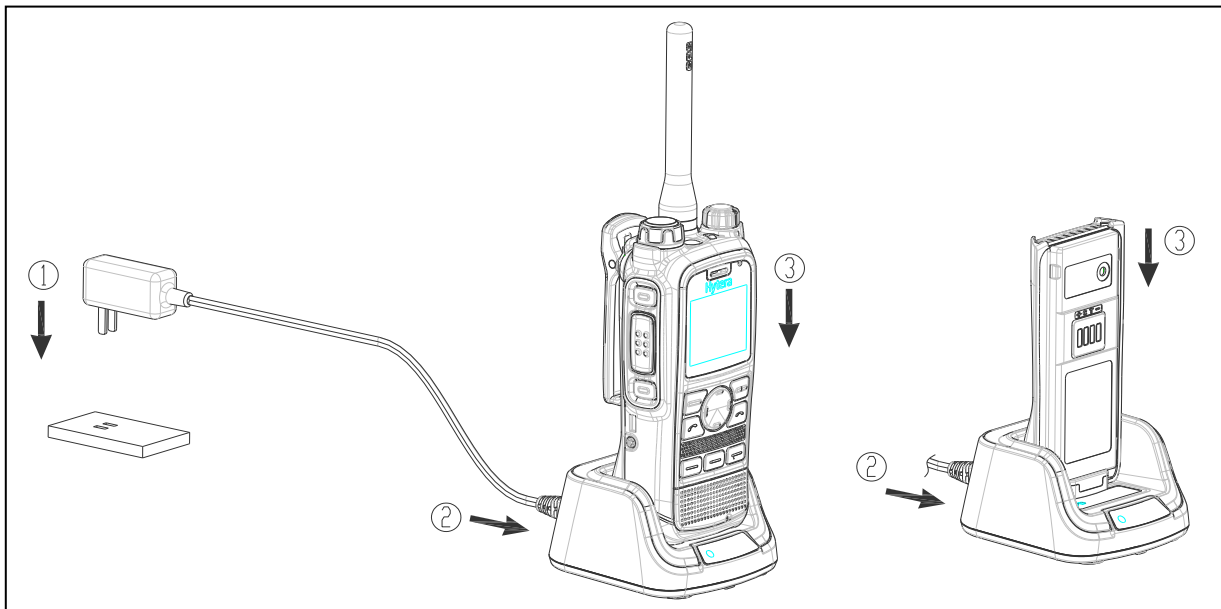

Charging status indication on charger:

LED Indication	Charging Status
Flashes red slowly	Standby (no load)
Glowes red	Charging
Glowes orange	90% charged
Glowes green	Fully charged
Flashes red rapidly	Charging failed

4. Basic Operations

4.1 Turning On/Off the Terminal

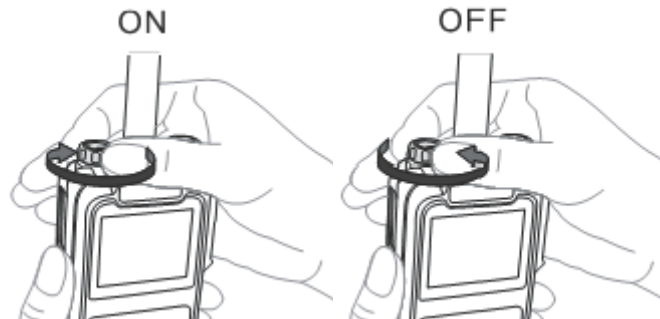

4.2 Switching Operation Mode

This terminal can operate in either TMO or DMO.

Press the **Func/OK** key on the home screen to enter the “Mode” menu, and then select “TMO” or “DMO” to switch the operation mode.

4.3 Adjusting the Call Volume



4.4 Selecting a Group



4.5 Managing the PhoneBook

PhoneBook is used to save the individual call number and PABX/PSTN number.

You can press the **Func/OK** key and go to “PhoneBook” menu to add, view, search, modify or delete acontact.

5. TMO Service

The trunked mode operation (TMO) supports either half-duplex or full-duplex operation and allows the terminals to communicate with each other via the TETRA network infrastructure. Thus features that require network access are available. To operate in TMO mode, the terminal must be authorized by your service provider, and must register with the network and stay within the network coverage.

5.1 Individual Call

An individual call is a half-duplex or full-duplex call initiated by an individual user to another individual user. You can initiate and receive an individual call to/from an individual contact.

Initiating an Individual Call

- Half-duplex Individual Call

Step 1 Press the **Func/OK** key and go to “PhoneBook” menu to select an individual contact.

Step 2 Hold down the **PTT** key to initiate a half-duplex individual call.

Step 3 Hold down the **PTT** key to talk after the call is established.

- Full-duplex Individual Call

Step 1 Press the **Func/OK** key and go to “PhoneBook” menu to select an individual contact.

Step 2 Press  to initiate a full-duplex individual call.

Step 3 Both parties can talk at any time without any operation after the call is established.

Answering an Individual Call

- Half-duplex Individual Call

- In case of an incoming call with Direct Signaling, the terminal will emit an alert tone to indicate that the call is established successfully. At this time, no operation is required to answer the call.
- In case of an incoming call with Hook Signaling, the terminal will ring and vibrate to indicate this incoming call. At this time, press **PTT** to answer the call.

Hold down the **PTT** key to talk after the call is established.

- Full-duplex Individual Call

- In case of an incoming call with Direct Signaling, the terminal will emit an alert tone to indicate that the call is established successfully. At this time, no operation is required to answer the call.
- In case of an incoming call with Hook Signaling, the terminal will ring and vibrate to indicate this incoming call. At this time, press **PTT** to answer the call.

Both parties can talk at any time without any operation after the call is established.

Ending an Individual Call

Press  to end the call.

5.2 Group Call

A group call is a half-duplex call initiated by an individual user to other members in a predetermined group. You can initiate a group call to the default group, and receive group calls from the members of the group.

Initiating a Group Call

On the home screen, rotate the **Group Selector** knob to select a group and hold down the **PTT** key to initiate a group call to this group, whose number is displayed on the home screen.

Answering a Group Call

You can answer a group call without any operation.

Ending/Exiting a Group Call



- The calling party can press  to end the group call.
- The called party can press  to exit the group call.

5.3 PABX/PSTN Call

A PABX/PSTN call is a full-duplex individual call with Hook Signaling established between an individual user and a PABX or PSTN user outside the TETRA network.

The operations for initiating a PABX/PSTN call are as follows. For operations of answering or ending a PABX/PSTN call, refer to [5.1 Individual Call](#).

Initiating a PABX/PSTN Call

- Step 1** On the home screen, press the **Func/OK** key to go to “Settings -> Network” and select “PSTN GW” or “PABX GW”.
- Step 2** Return to the home screen and input a PABX or PSTN number.
- Step 3** Press the **Func/OK** key to select “PABX” or “PSTN” if  appears on the screen.
Skip this step if  does not appear on the screen.
- Step 4** Press  to initiate the call.

5.4 Emergency Call

An Emergency call is a call initiated by an individual user to the predefined contact for summoning help in urgent situations. With the highest priority, it can interrupt any other ongoing calls with lower priority if

no resource is available.

Initiating an Emergency Call

Hold down the **Emergency** key for the preset time to initiate an emergency call to the predefined contact which can be the individual, group, PABX or PSTN user.

Answering an Emergency Call

You can answer an emergency individual call or emergency group call without any operation.

As for an emergency PABX/PSTN call, you need to press the **PTT** key to answer the call.

Ending/Exiting an Emergency Call

For ending operation, refer to [5.1 Individual Call](#), [5.2 Group Call](#) or [PABX/PSTN Call](#) according to the predefined contact.

5.5 Message Service

Message Service allows you to send and receive a message, which includes Status Message and User Message. Status Message is programmed by your dealer only while User Message allows you to create, edit and send a text message.

Sending a Message

- Step 1** Press the **Func/OK** key to go to “Message -> New Msg” and select “Status Msg”.
- Step 2** For status message, select “View -> Options” and then select “Individual” or “Group”; for user message, press **Func/OK** key to select “Individual” or “Group” after editing the message.
- Step 3** Enter the individual number or select a group contact, and press the **Func/OK** key to send the message.

Viewing a Message

- Step 1** On the home screen, press the **Func/OK** key to go to “Message -> Inbox”, and select the appropriate message.
- Step 2** Press the **Func/OK** key to view the content.

6. DMO Service

The direct mode operation (DMO) supports half-duplex operation and allows the terminals to communicate directly with each other, without using a TETRA network infrastructure. Thus features that require network access will be unavailable.

6.1 Individual Call

An individual call is a half-duplex call initiated by an individual user to another individual user. You can initiate and receive an individual call to/from an individual contact.

Initiating an Individual Call

Step 1 Press the **Func/OK** key and go to “PhoneBook” menu to select an individual contact.

Step 2 Hold down the **PTT** key to initiate the call.

Step 3 Hold down the **PTT** key to talk after the call is established.

Answering an Individual Call

You can answer the call without any operation.

Ending an Individual Call

Press  to end the call.

6.2 Group Call

The group call operations in DMO are similar to those in TMO. Refer to [5.2 Group Call](#) for details.

6.3 Emergency Call

An Emergency call is a call initiated by an individual user to the default group for summoning help in urgent situations. With the highest priority, it can interrupt any other ongoing calls with lower priority if no resource is available.

Initiating an Emergency Call

Hold down the **Emergency** key for the preset time to initiate an emergency call to the default group.

Answering an Emergency Call

You can answer an emergency individual call or group call without any operation.

Ending/Exiting an Emergency Call

- The calling party can press  to end the Emergency call.
- The called party can press  to exit the Emergency call.

6.4 Message Service

The message operations in DMO are similar to those in TMO. Refer to [5.5 Message Service](#) for details.

7. Troubleshooting

Phenomenon	Analysis	Solution
Terminals cannot be powered on.	The battery power may be too low to power on the terminal.	Charge the battery.
Network registration fails or network cannot be found.	The terminal may be operating in DMO.	Switch to TMO.
	The terminal may be out of the network coverage in TMO.	Check the signal strength. Make sure the terminal is within the network coverage.
	The terminal may not be granted network access.	Contact the network operator for the terminal authorization.
Calls cannot be established.	The terminal or the called party may be out of the network coverage.	Check the signal strength. Make sure the terminal is within the network coverage.
	The terminal may operate in an improper mode.	Check the operation mode. Make sure the terminal works in the right mode.
A certain group call cannot be initiated or received.	The terminal may not be a member of the target group.	Check whether the terminal is a member of the group. If not, contact your dealer to add the terminal to the group.
	The terminal may not be authorized to access the target group.	Contact the network operator for the terminal authorization.
Calls are always interrupted.	The current channel may be assigned to emergency calls or other calls with higher priority.	Wait until the channel becomes available and try again.
A half-duplex call cannot be established.	The predefined time period for establishing a call may expire.	Make sure the call is established within the predefined time period.
	The channel may be occupied by	Wait until the channel becomes

	another terminal with higher call priority.	available and try again.
	The channel resources may be allocated to other services due to overloaded network.	Wait until the channel becomes available and try again.
Abnormal disconnection occurs during a call.	The terminal may be out of the network coverage in TMO.	Check the signal strength. Make sure the terminal is within the network coverage.
	The terminal may operate at an unfavorable position where communication may be blocked by high buildings or frustrated in the underground areas in DMO.	Move to an open and flat area, and restart the terminal.
As for the same status message ID, the content displayed at the receiving party is different from that of the sending party.	The parties may have associated the same status message ID with different contents.	Make sure the status message ID is associated with the same content.

If the above solutions cannot fix your problems, or you may have some other queries, please contact us or your local dealer for more technical support.

8. Care and Cleaning

To guarantee optimal performance as well as a long service life of the product, please follow the tips below.

Product Care

- Do not pierce or scrape the product.
- Keep the product far away from substances that can corrode the circuit.
- Do not hold the product by its antenna or earpiece cable directly.
- Attach the accessory connector cover when the product is not in use.

Product Cleaning

Caution

Power off the product and disconnect the power supply before cleaning.

- Clean up the dust and fine particles on the product surface and charging piece with a clean and dry lint-free cloth or a brush regularly.
- Use neutral cleanser and a non-woven fabric to clean the keys, control knobs and front case after long-time use. Do not use chemical preparations such as stain removers, alcohol, sprays or oil preparations, so as to avoid surface case damage.
- Make sure the product is completely dry before use.

9. Optional Accessories

Please contact your local dealer or us for more details on the main optional accessories of the product.

Caution

Use the accessories specified by the Company only. If not, the Company shall not be liable for any losses or damages arising out of use of unauthorized accessories.

10. FCC STATEMENT

This device complies with Part 15 of the FCC Rules. Operation is subject to the following two conditions:

- (1) This device may not cause harmful interference, and
- (2) this device must accept any interference received, including interference that may cause undesired operation.

NOTE 1: This equipment has been tested and found to comply with the limits for a Class B digital device, pursuant to part 15 of the FCC Rules. These limits are designed to provide reasonable protection against harmful interference in a residential installation.

This equipment generates, uses and can radiate radio frequency energy and, if not installed and used in accordance with the instructions, may cause harmful interference to radio communications. However, there is no guarantee that interference will not occur in a particular installation. If this equipment does cause harmful interference to radio or television reception, which can be determined by turning the equipment off and on, the user is encouraged to try to correct the interference by one or more of the following measures:

- Reorient or relocate the receiving antenna.
- Increase the separation between the equipment and receiver.
- Connect the equipment into an outlet on a circuit different from that to which the receiver is connected.
- Consult the dealer or an experienced radio/TV technician for help.

NOTE 2: Any changes or modifications to this unit not expressly approved by the party responsible for compliance could void the user's authority to operate the equipment.

IC STATEMENT

This device complies with Industry Canada licence-exempt RSS standard(s): Operation is subject to the following Two conditions:(1) this device may not cause interference, and (2) this device must accept any interference, including interference that may cause undesired operation of the device.

Le présent appareil est conforme aux CNR d'Industrie Canada applicables aux appareils radio exempts de licence. L'exploitation est autorisée aux deux conditions suivantes : (1) l'appareil ne doit pas produire de brouillage, et (2) l'utilisateur de l'appareil doit accepter tout brouillage radioélectrique subi, même si le brouillage est susceptible d'en compromettre le fonctionnement.

The information listed above provides the user with information needed to make him or her aware of a RF exposure, and what to do to assure that this radio operates within the FCC exposure limits of this radio. compliance for body worn operating configurations is limited to the specific belt clip, holster, accessories tested for this product

The device complies with RF specifications when the device used at 25mm from your front face and 0mm from your body, Third-party belt-clips, holsters, and similar accessories used by this device should not contain any metallic components. Body-worn accessories that do not meet these requirements may not comply with RF exposure requirements and should be avoided. Maximun SAR Value (1g): 2.62W/Kg.