

## Preface

Thanks for your favor in our product. To derive optimum performance from the product. To ensure you get maximum benefit from the product, please read this manual carefully before use.

This manual is applicable to the following model:

RD98XS U(2) (X may indicate 0, 2, 5, 6 or 8)

## Instructional Icons

The following icons are available through this manual:



**Caution:** indicates situations that could cause damage to your product.



**Note:** indicates tips that can help you make better use of your product.

**\*** : indicates functions available in later version.

## Term Explanation

### Duplexer

Duplexer is a device that allows bi-directional communication. Its role is to isolate the TX signal from the RX signal to ensure that the transmitter and receiver can work normally.

### Feed Line

Feed Line is the cable or transmission line that connects the antenna with the radio transmitter or receiver.

### Voltage Standing Wave Ratio (VSWR)

VSWR is a value that measures how well a load is impedance-matched to a source.

### Squelch

Squelch is a circuit function that acts to suppress the audio output of a receiver in the absence of a sufficiently strong desired input signal.

## Copyright Information

Hytera is the trademark or registered trademark of Hytera Communications Co., Ltd. (the Company) in PRC and/or other countries or areas. The Company retains the ownership of its trademarks and product names. All other trademarks and/or product names that may be used in this manual are properties of their respective owners.

The product described in this manual may include the Company's computer programs stored in memory or other media. Laws in PRC and/or other countries or areas protect the exclusive rights of the Company with respect to its computer programs. The purchase of this product shall not be deemed to grant, either directly or by implication, any rights to the purchaser regarding the Company's computer programs. Any of the Company's computer programs may not be copied, modified, distributed, decompiled, or reverse-engineered in any manner without the prior written consent of the Company.

The AMBE+2™ voice coding technology embodied in this product is protected by intellectual property rights including patent rights, copyrights and trade secrets of Digital Voice Systems, Inc. This voice coding technology is licensed solely for use within this product. The user of this technology is explicitly prohibited from attempting to decompile, reverse engineer, or disassemble the Object Code or in any other way convert the Object Code into a human readable form.

U.S. Patent Nos. #6,912,495 B2, #6,199,037 B1, #5,870,405, #5,826,222, #5,754,974, #5,701,390, #5,715,365, #5,649,050, #5,630,011, #5,581,656, #5,517,511, #5,491,772, #5,247,579, #5,226,084 and #5,195,166.

## Disclaimer

The Company endeavors to achieve the accuracy and completeness of this manual, but no warranty of accuracy or reliability is given. All the specifications and designs are subject to change without notice due to continuous technology development. No part of this manual may be copied, modified, translated, or distributed in any manner without the express written permission of us.

If you have any suggestions or would like to learn more details, please visit our website at: <http://www.hytera.com/>.

## RF Radiation Information

### RF Radiation Profile

Radio Frequency (RF) is a frequency of electromagnetic radiation in the range at which radio signals are transmitted. RF technology is widely used in communication, medicine, food processing and other fields. It may generate radiation during use.

### RF Radiation Safety

In order to ensure user health, experts from relevant industries including science, engineering, medicine and health work with international organizations to develop standards for safe exposure to RF radiation. These standards consist of:

- United States Federal Communications Commission, Code of Federal Regulations; 47CFR part 2 sub-part J;
- American National Standards Institute (ANSI)/Institute of Electrical and Electronic Engineers (IEEE)

C95. 1-1992;

- Institute of Electrical and Electronic Engineers (IEEE) C95. 1 – 1999;
- International Commission on Non-Ionizing Radiation Protection (ICNIRP) 1998;

## **FCC Regulations**

Federal Communication Commission (FCC) requires that all radio communication products should meet the requirements set forth in the above standards before they can be marketed in the U.S, and the manufacturer shall post a RF label on the product to inform users of operational instructions, so as to enhance their occupational health against exposure to RF energy.

This device complies with part 15 of the FCC Rules. Operation is subject to the following two conditions: (1) This device may not cause harmful interference, and (2) this device must accept any interference received, including interference that may cause undesired operation.

Any Changes or modifications not expressly approved by the party responsible for compliance could void the user's authority to operate the equipment.

## **Compliance with RF Exposure Standards**

To control your exposure and ensure compliance with the occupational/controlled environment exposure limits, this equipment should be operated with minimum distance 350cm between the radiator& your body.

Pour contrôler votre exposition et assurer le respect des valeurs limites d'exposition professionnelles environnement / contrôlée, cet équipement doit être utilisé avec une distance minimale de 350 cm entre le radiateur et votre corps.

## **Operational Instructions and Training Guidelines**

To ensure optimal performance and compliance with the occupational/controlled environment RF energy exposure limits in the above standards and guidelines, users should always adhere to the followings:

- Gain of antenna must not exceed 6.5dBi.
- Antenna Installation: install the antenna at least 3.5 meters away from your body, in accordance with the requirements of the antenna manufacturer/supplier.

## **EU Regulatory Conformance**

As certified by the qualified laboratory, the product is in compliance with the essential requirements and other relevant provisions of the Directive 1999/5/EC. Please note that the above information is applicable to EU countries only.

## IC Regulations

This device complies with Industry Canada licence-exempt RSS standard(s). Operation is subject to the following two conditions:

- (1) this device may not cause interference, and
- (2) this device must accept any interference, including interference that may cause undesired operation of the device.

Le présent appareil est conforme aux CNR d'Industrie Canada applicables aux appareils radio exempts de licence. L'exploitation est autorisée aux deux conditions suivantes :

- (1) l'appareil ne doit pas produire de brouillage, et
- (2) l'utilisateur de l'appareil doit accepter tout brouillage radioélectrique subi, même si le brouillage est susceptible d'en compromettre le fonctionnement

This radio transmitter (identify the device by certification number, or model number if Category II) has been approved by Industry Canada to operate with the antenna types listed below with the maximum permissible gain and required antenna impedance for each antenna type indicated. Antenna types not included in this list, having a gain greater than the maximum gain indicated for that type, are strictly prohibited for use with this device.

Le présent émetteur radio (identifier le dispositif par son numéro de certification ou son numéro de modèle s'il fait partie du matériel de catégorie I) a été approuvé par Industrie Canada pour fonctionner avec les types d'antenne énumérés ci-dessous et ayant un gain admissible maximal et l'impédance requise pour chaque type d'antenne. Les types d'antenne non inclus dans cette liste, ou dont le gain est supérieur au gain maximal indiqué, sont strictement interdits pour l'exploitation de l'émetteur.

# Contents

Checking Items in the Package .....	1
Product Overview .....	2
Front Panel.....	2
Programmable Keys * .....	2
Rear Panel .....	3
Internal Parts.....	3
Installation Guide.....	4
Installation Requirements.....	4
Before Installation.....	4
Installation Steps .....	5
After-installation Verification .....	7
Status Indication .....	7
LCD Icon .....	7
LED Indicator .....	8
Basic Operations .....	8
Turning the Repeater On/Off.....	8
Adjusting the Volume .....	9
Adjusting the Power Level.....	9
Backlight.....	9
Locking/Unlocking the Repeater .....	9
Changing the Channel .....	9
Menu Navigation .....	10
Radio Info.....	10
Channel Info.....	11
Scan.....	11
Digital Speaker .....	12
Exit .....	13
Alarm Information .....	13

Over Temperature Alarm .....	13
Fan Failure Alarm .....	14
VSWR Alarm .....	14
Low Forward Power Alarm .....	15
Over/Low Voltage Alarm .....	15
TX/RX Unlock Alarm.....	16
Troubleshooting.....	17
Care and Cleaning .....	18
Optional Accessories.....	19

# Checking Items in the Package

Please unpack carefully and check that all items listed below are received. If any item is missing or damaged, please contact your dealer.

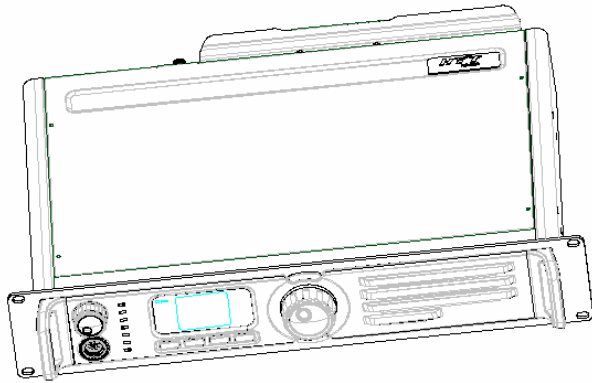

Base station

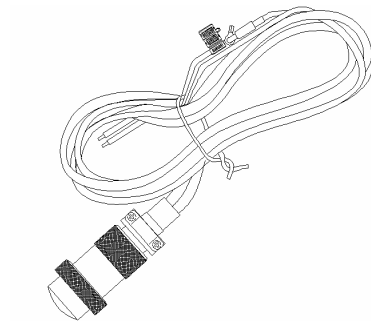

Power Cord



# Product Overview

## Front Panel

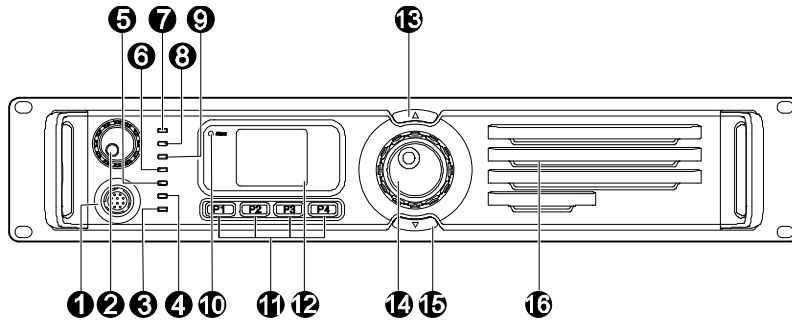

No.	Part Name	No.	Part Name
1	Accessory Jack	9	Slot 1 RX Indicator
2	Volume Control Knob / Power Indicator	10	Alarm Indicator
3	Repeat Mode Indicator	11	Programmable Key *
4	Analog Mode Indicator	12	LCD Display
5	Slot 2 RX Indicator	13	Channel Up (CH+)
6	Slot 2 TX Indicator	14	Navigation Knob
7	Digital Mode Indicator	15	Channel Down (CH-)
8	Slot 1 TX Indicator	16	Speaker

## Programmable Keys \*

For enhanced convenience, you can request your dealer to program the keys **P1**, **P2**, **P3** and **P4** as shortcuts to appropriate functions.

## Rear Panel

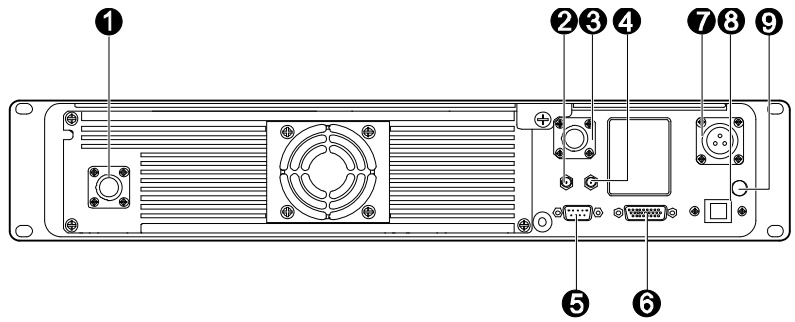

No.	Part Name	No.	Part Name
1	TX Antenna Interface	6	Accessory Jack
2	Optional Interface 1	7	DC Power Interface
3	RX/Duplex Antenna Interface	8	Ethernet Port *
4	Optional Interface 2	9	Ground Screw
5	Monitor/Tuning Interface		

## Internal Parts

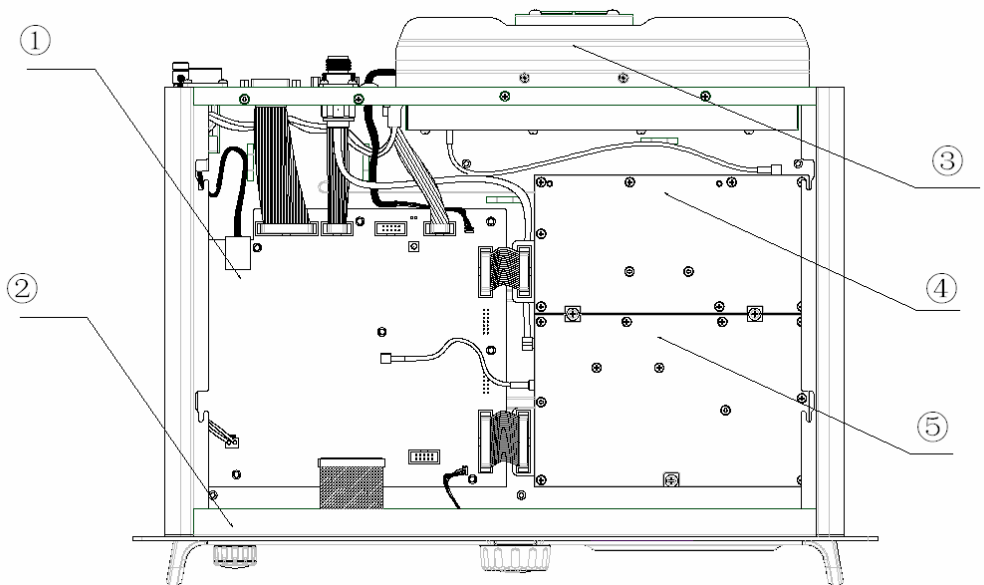

No.	Part Name	No.	Part Name
-----	-----------	-----	-----------

1	Baseband Module	4	Exciter Module
2	Front Panel	5	Receiver Module
3	PA Module		

# Installation Guide

Proper installation can ensure optimum performance and reliability of the repeater. Therefore, be sure to read the following instructions before installation.

## Installation Requirements

- **Installation Environment**

The repeater must be installed in a dry and well-ventilated place with ambient temperature of  $-30^{\circ}\text{C}\sim+60^{\circ}\text{C}$  and relative humidity of less than 95%.

- **Installation Location**

The repeater can be installed in a rack, bracket, cabinet or on a desk.

- **Installation Tools**

Tools required for installing the repeater include a cross head screwdriver, a torx screwdriver and a spanner.



**Note:** Please refer to *Safety Information Booklet* for more information.

## Before Installation

1. **Voltage Check**

Please check whether the voltage of DC power or battery meets the repeater specifications.

2. **Product Check**

Please check whether the repeater works properly by observing the 8 LEDs located in the front panel.

3. **Parameter Configuration**

When the repeater proves to work normally, configure appropriate parameters according to your actual requirements. And then you can proceed with on-site installation.

# Installation Steps

Install the repeater as follows:

1. Install the repeater at a proper location;
2. Attach all necessary accessories;
3. Ground the repeater through the Ground Screw located on the rear panel.

## Installing the Duplexer

If the repeater needs to work with a duplexer, you should implement the following operations before installation.

1. Loosen the three screws on the bracket with a cross head screwdriver. See the figure below.

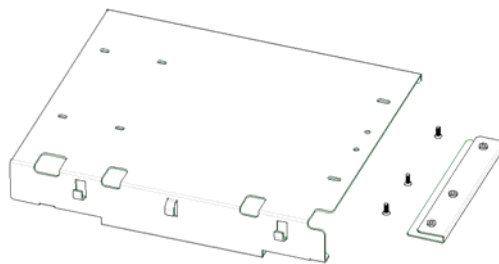

2. Install the duplexer onto the bracket.

Be sure to observe the specifications of two antenna connectors on the duplexer, to determine which one should be connected to the transmitter. The connector connecting the transmitter should be close to the PA module to reduce RF loss, as shown below:



3. Loosen the screw at the back of the top cover, and then pull the top cover to remove it.

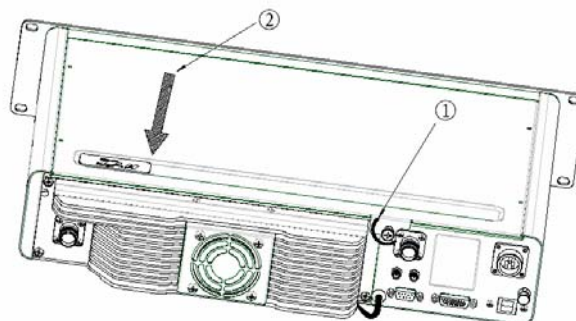

4. Loosen the 6 screws locking the PA heat sink, remove all power, data and RF cables from the PA, and finally remove the PA heat sink. See the figure below.

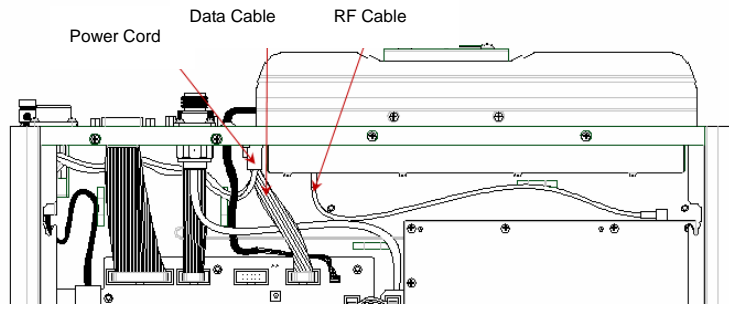

5. Connect the RF cable. See the figure below.

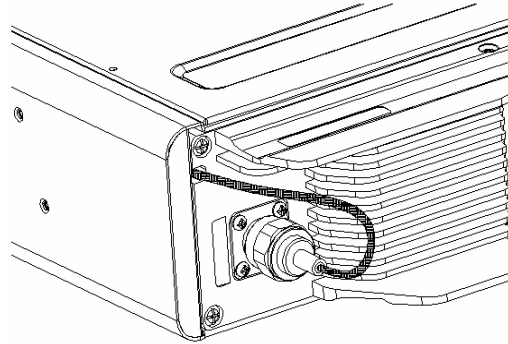

6. Install the duplexer to the repeater.

After the duplexer is mounted properly, fasten it with the 2 screws inside the housing and on the side respectively.

7. Then attach the PA heat sink and connect all cables.

8. Close the repeater cover.

### Installation Diagram

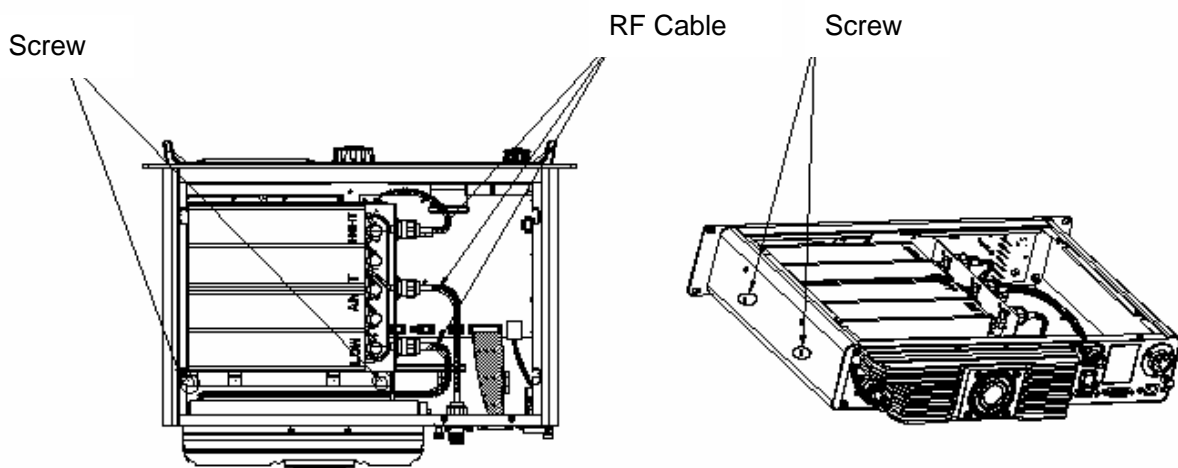

Duplexer with Front Side Facing Upwards

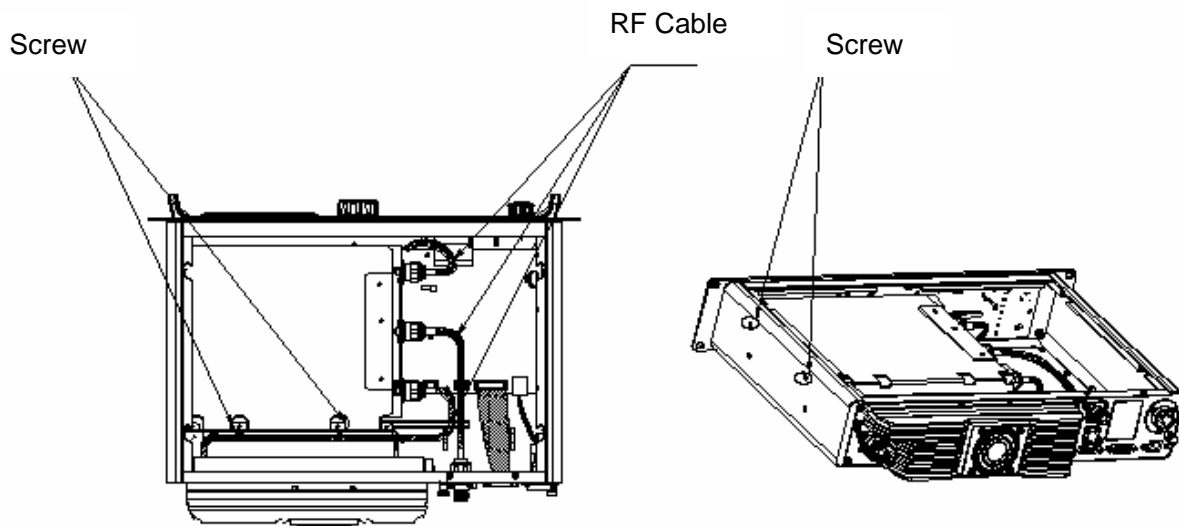

Duplexer with Front Side Facing Downwards

## After-installation Verification



After installation is completed, power it on and verify whether it works properly by observing the 8 LEDs located in the front panel.

## Status Indication

### LCD Icon

These icons may appear on the LCD to help you easily identify the repeater status.

Icon Name	Icon	Repeater Status
RSSI Indicator *		More bars indicate better signal strength.
TX Power Indicator		Low TX power for the current channel.
		High TX power for the current channel.
Scan Indicator		Scan is in progress.
Monitor Indicator *		The Monitor feature is active.
Speaker Indicator		The speaker is unmuted.

Alarm Indicator		An alarm message is given.
Accessory Indicator *		An accessory is connected.
Scrambler/Encrypt Indicator		The Scrambler/Encrypt feature is active.
Operation Mode Indicator	RM	The repeater is operating in Repeat mode.

## LED Indicator

LED Indication	Part No.	Repeater Status
Power Indicator glows green.	2	Normal power-on
Alarm Indicator glows red.	10	Abnormal operation
Repeat Mode Indicator glows green.	3	The repeater is operating in Repeat mode.
Repeat Mode Indicator goes out.	3	The repeater is operating in Base mode.
Slot 1 TX Indicator glows red.	8	The repeater is transmitting on an analog channel or on slot 1.
Slot 1 RX Indicator glows green.	9	The repeater is receiving on an analog channel or on slot 1.
Slot 2 TX Indicator glows red.	6	The repeater is transmitting on slot 2.
Slot 2 RX Indicator glows green.	5	The repeater is receiving on slot 2.
Analog Mode Indicator glows yellow.	4	The repeater is operating in Analog mode.
Digital Mode Indicator glows blue.	7	The repeater is operating in Digital mode.

# Basic Operations

## Turning the Repeater On/Off

- **ON:** To power up the repeater, connect a DC power supply to it. In this case, the repeater shows

power-up screen and the Power Indicator glows green.



- **OFF:** To power off the repeater, disconnect the DC power supply.

## Adjusting the Volume

- **On an analog channel:** Rotate the **Volume Control** knob clockwise to increase the volume or counter-clockwise to decrease it.
- **On a digital or mixed channel:** This knob does not work.

## Adjusting the Power Level

You may request your dealer to set the TX power to High or Low. High power can extend the coverage, enabling you to communicate with farther terminals.

There are two levels available: High (indicated by ) and Low (indicated by )

## Backlight

Activating the backlight can illuminate the LCD and all the front panel keys, so as to facilitate your operation under dim light conditions.

Your dealer may set the backlight to operate in any of the following modes:

- **Timed:** key press, knob operation or signal reception/transmission can activate the backlight. If no foregoing event occurs within the specified time period, the backlight will go out automatically.
- **Enable:** the backlight remains activated all the time.



**Note:** When an alarm event occurs, the backlight will remain activated until the alarm disappears.

## Locking/Unlocking the Repeater

You can request your dealer to lock the knob and all keys in the front panel to prevent accidental operation. To unlock, the repeater must be re-programmed by your dealer.

## Changing the Channel

You can use the **Channel Up** or **Channel Down** key in the front panel to change the channel cyclically.



The alias of the current channel is displayed on the LCD display.

## Menu Navigation

The options under the main menu vary with the channel type.

- Analog Channel

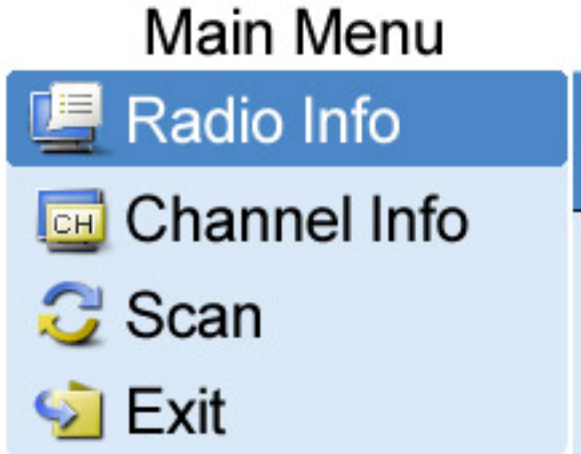

- Digital or Mixed Channel



### Radio Info

Under this menu, you can view product information, including Radio ID, Radio Alias, Serial Number, Radio Model, Freq Range, Firmware Ver, RCDB Ver, Bootload Ver, Program Date and En Lang Ver.

To access this menu:

1. In the home screen, press the **Navigation** knob to enter the main menu.
2. Rotate this knob to select the "Radio Info" option.
3. Press this knob again to view details.

In the above interface, you can rotate the **Navigation** knob to scroll through related information. To exit and return to the main menu, press the knob.



Note: If a non-English package is programmed into your repeater, the "Other Lang Ver" will appear under this menu.

## Channel Info

Under this menu, you can view channel information. The LCD will display different channel items as per the channel type.

Channel Type	Channel Information
Digital Channel	CH Alias, TX Frequency, RX Frequency, Color Code
Analog Channel	CH Alias, TX Frequency, RX Frequency, CH Band, TX CTCSS/CDCSS, RX CTCSS/CDCSS
Mixed Channel	CH Alias, TX Frequency, RX Frequency, CH Band, TX CTCSS/CDCSS, RX CTCSS/CDCSS, Color Code

To access this menu:

1. In the home screen, press the **Navigation** knob to enter the main menu.
2. Rotate this knob to select the "Channel Info" option.
3. Press this knob again to view details.

In the above interface, you can rotate the **Navigation** knob to scroll through related information. To exit and return to the main menu, press the knob.

## Scan

The Scan feature allows you to listen to communication activities on other channels so that you can keep a close track of your team members. You can request your dealer to create a scan list for each channel. Each list may contain 32 channels at most.

To access this menu:

1. In the home screen, press the **Navigation** knob to enter the main menu.
2. Rotate this knob to select the "Scan" option.
3. Press this knob again to access the "Scan on/off" interface.

## Scan on/off

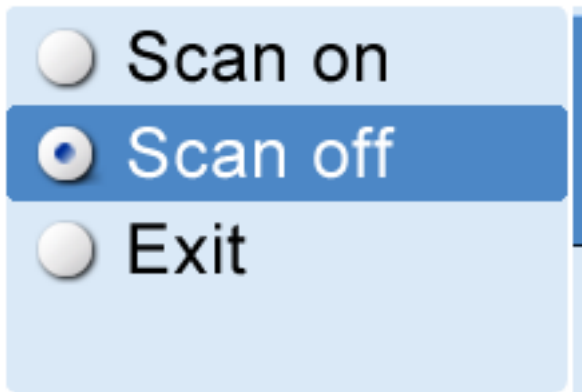

In the above interface, you can enable or disable the Scan feature. To exit and return to the main menu, press the knob.



**Note:** If the "Scan" option is not checked in the CPS by your dealer, you can not enable or disable the Scan feature via this menu.

## Digital Speaker

The Digital Speaker feature allows your repeater to receive audio from a specific slot, or to mute for the digital channel.

To access this menu:

1. In the home screen, press the **Navigation** knob to enter the main menu.
2. Rotate this knob to select the "Digital Speaker" option.
3. Press this knob again to access the "Digital Speaker" interface.

## Digital Speaker

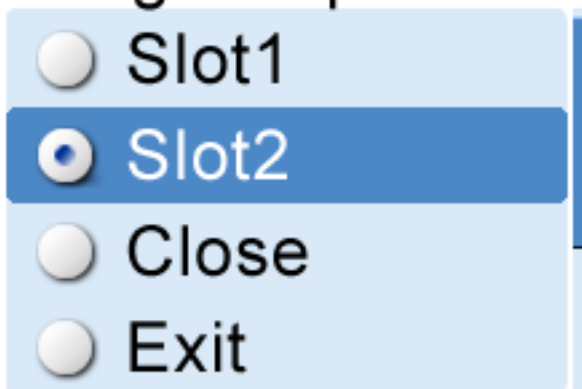

In the above interface, you can select a specific slot to receive, or mute the speaker for the digital channel. To exit and return to the main menu, press the knob.

## Exit

To exit the main menu:

1. In the main menu, rotate the **Navigation** knob to select the "Exit" option.
2. Press this knob to return to the home screen.

## Alarm Information

The repeater can automatically detect its operation status in real time. If the appropriate alarm indication option is checked in the CPS by your dealer, the LCD will give you a prompt message, and the Alarm Indicator will glow red in the case of a corresponding abnormality.

### Over Temperature Alarm

When the temperature of the PA module exceeds the normal range, the Alarm Indicator will glow red and the LCD will display the prompt message below:



Then the repeater will stop transmitting, and you need to:

1. Check whether the temperature of the heat sink surface is over 80°C. If yes, proceed with Step 2 and 3 to find out the cause.

 **Caution:** DO NOT touch the heat sink surface to avoid burn. You can use a digital thermometer with thermocouple to measure the temperature value.

2. Check whether ambient temperature and ventilation conditions satisfy the foregoing installation requirements. If not, please make improvements as soon as possible.
3. Check if connection between the transmitter and RF cable or antenna feed line is loose or damaged. Poor connection between them could cause high TX power, which would make the temperature of the heat sink rise quickly. If yes, secure or replace the cable or antenna feed line.

4. If the above measures fail to solve the problem, contact your local dealer for technical support.

When temperature falls into normal range, the prompt message will disappear, and the Alarm Indicator will go out.

## Fan Failure Alarm

When the fan fails to work, the Alarm Indicator will glow red and the LCD will display the prompt message below:

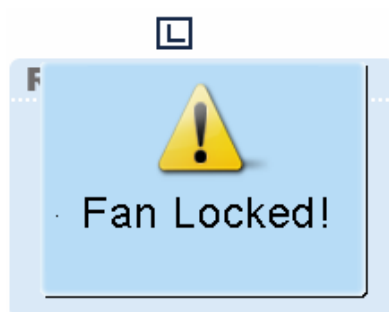

Then the repeater will automatically work at low TX power, to protect the transmitter from overheating.

You need to:

1. Check whether the fan is blocked by a foreign object. If yes, remove it.
2. If you cannot solve the problem, contact your local dealer for technical support.

When the fan recovers normal operation, the prompt message will disappear, and the Alarm Indicator will go out.

## VSWR Alarm

High VSWR (voltage standing wave ratio) of TX antenna connector could result in damage to the PA, and even failure of the transmitter. When the VSWR exceeds the normal range, the Alarm Indicator will glow red and the LCD will display the prompt message below:



Then the repeater will automatically works at low TX power. You need to:

1. Check if the operating frequency of the repeater is in line with that of the antenna. Both frequency

mismatch and improper antenna could result in poor transmitting performance and even damage to the transmitter. If yes, please contact your local dealer to replace the antenna or reprogram your product.

2. Check if the connection between the transmitter and RF cable or antenna feed line is loose or damaged. If yes, secure or replace the cable or antenna feed line.

3. If you cannot solve the problem, contact your local dealer for technical support.

When the VSWR falls within the normal range, the prompt message will disappear, and the Alarm Indicator will go out.

## Low Forward Power Alarm

When the forward power is below the preset value, the Alarm Indicator will glow red and the LCD will display the prompt message below:



Then the repeater may continue transmission or terminate it, subject to the detection result. You need to:

1. Check if the connection between the transmitter and RF cable or antenna feed line is loose or damaged. If yes, secure or replace the cable or antenna feed line.

2. If you cannot solve the problem, contact your local dealer for technical support.

When the forward power is recovered to its normal value, the prompt message will disappear, and the Alarm Indicator will go out.

## Over/Low Voltage Alarm

When power voltage is detected to be over or below the range (11V-15.6V) of repeater, the Alarm Indicator will glow red and the LCD will display the prompt message below:

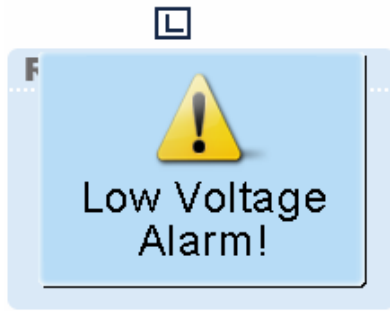

Low Voltage Alarm

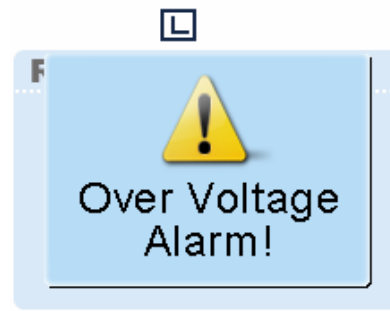

Over Voltage Alarm

Then the repeater will automatically stop working. You need to:

1. Check whether the power voltage is too low or too high. If yes, replace the DC power supply or external battery.
2. Check whether the power cord is loose or damaged. If yes, secure or replace the cord.
3. If you cannot solve the problem, contact your local dealer for technical support.

When the voltage falls within the normal range, the prompt message will disappear, and the Alarm Indicator will go out.

**⚠Caution:** If low voltage is detected when the repeater is powered by an external battery, please charge it in time. Disconnect the battery from the repeater before charging.

## TX/RX Unlock Alarm

When the TX PLL or RX PLL is unlocked, the Alarm Indicator will glow red and the LCD will display the prompt message below:

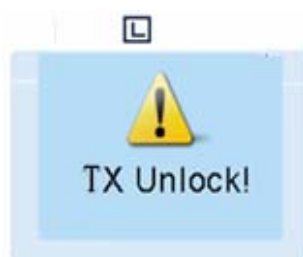

TX Unlock Alarm

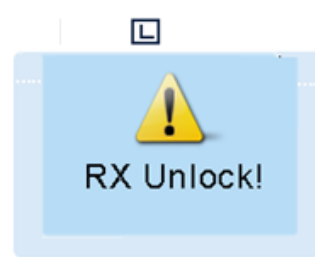

RX Unlock Alarm

Then the repeater will automatically stop partial operations. You need to:

1. Disconnect the power supply, open the chassis and check whether the cabling is right or damaged. If yes, please secure or replace the cable.
2. If you cannot solve the problem, contact your local dealer for technical support.

When the PLL recovers normal operation, the prompt message will disappear, and the Alarm Indicator will go out.

 **Caution:** Disconnect the power supply before opening the chassis!

## Troubleshooting

Phenomena	Analysis	Solution
The repeater cannot be powered on.	Power cord is not connected or is not securely connected to the outlet.	Properly connect the power cord and ensure secure connection. Check if the fuse has blown. If
	Power cord fuse is damaged.	Check if the fuse has blown. If yes, replace it with a new one.
Group members cannot talk to each other, or the repeater cannot communicate with a subscriber radio.	TX/RX frequency of the repeater is inconsistent with that of portable/mobile terminals.	Re-set frequencies.
	Failed to repeat useful signal due to strong interference signal.	If you cannot remove or bypass the interference source, change to operate at other frequencies.
	The group member is out of the coverage of the repeater.	Go within the coverage of the repeater.
Group members cannot talk to each other, even though RX indication is given.	Your ID is inconsistent with that of other group members.	Set your ID to the same as that of other members.
	Inconsistent CTCSS/CDCSS.	Re-set CTCSS/CDCSS.
Short communication range or poor audio	Leakage of signal energy due to damaged connection cable.	Replace the cable with a new one if necessary.
	Loose connection between the antenna connector and the cable, or loss of connection	Secure or replace the cable.



	Invisible damage to the cable.	Replace the cable with a new one.
	Duplexer is not properly set (if the duplexer is mounted).	Contact the manufacturer or your dealer to re-set the duplexer.

If the above solutions can not fix your problems, or you may have some other queries, please contact us or your local dealer for more technical support.

## Care and Cleaning

To guarantee optimal performance as well as a long service life of the product, please follow the tips below.

### Product Care

- Keep the product at a place of good ventilation and heat dissipation to facilitate normal work.
- Do not place irrelevant articles on top of the product to ensure optimal heat dissipation.
- Do not pierce or scrape the product with any edged instruments or hard objects.
- Keep the product far away from substances that can corrode the circuit.
- Do not place the product in corrosive agents, solutions or water.

### Product Cleaning

 **Caution:** Disconnect the power supply from the repeater before cleaning.

- Remove the dust and fine particles on the repeater surface with a clean and dry lint-free cloth or a brush regularly.
- Use a non-woven cloth with neutral cleanser to clean the keys, control knobs, LCD and jacks after long-time use. Never use chemical preparations such as stain removers, alcohol, sprays or oil preparations. Make sure the product is completely dry before use.

# Optional Accessories

The following items are the main optional accessories for the product, and please consult your local dealer for more other accessories.

		
Palm Microphone SM16A1	Desktop Microphone SM10A1	Duplexer Bracket BRK09 (for DT11 and DT14 only)
		
External Power Supply (240W, backup power supply applicable) PS22002	Bracket (2U)(black) BRK12	Bracket (2U)(grey) BRK14
		
Power Cord (10A 12AWG) PWC11	Fuse POA33	10-pin Programming Cable (USB) PC37
		
DB26 Data Cable (USB) PC40	Omni-directional Antenna	

**⚠ Caution:** Use the accessories specified by the Company only. If not, the Company shall not be liable for any losses or damages arising out of use of unauthorized accessories.