

Preface

Thank you for purchasing Hytera DMR Repeater. Combination of ergonomic design, versatile digital functions and remarkable quality would refresh your experience and enable you to be responsive to emergent situations.

To derive optimum performance from your product, please read this manual and the supplied Safety Information Booklet carefully before use.

The manual is applicable to the following model:

RD98X

Instructional Icons

The following icons are available through this manual:



Caution: indicates situations that could cause damage to your product.



Note: indicates tips that can help you make better use of your product.



: indicates functions available in later version.

Copyright Information

Hytera and HYT are trademarks or registered trademarks of Hytera Communications Co., Ltd. (“Hytera”) in PRC and/or other countries or areas. Hytera retains the ownership of its trademarks and product names. All other trademarks and/or product names that may be used in this manual are properties of their respective owners.

The Hytera product described in this manual may include Hytera computer programs stored in memory or other media. Laws in PRC and/or other countries or areas protect the exclusive rights of Hytera with respect to its computer programs. The purchase of this product shall not be deemed to grant, either directly or by implication, any rights to the purchaser regarding Hytera computer programs. Any Hytera computer programs may not be copied, modified, distributed, decompiled, or reverse-engineered in any manner without the prior written consent of Hytera.

The AMBE+2™ voice coding technology embodied in this product is protected by intellectual property rights including patent rights, copyrights and trade secrets of Digital Voice Systems, Inc.

This voice coding technology is licensed solely for use within this product. The user of this technology is explicitly prohibited from attempting to decompile, reverse engineer, or disassemble the Object Code or in any other way convert the Object Code into a human

readable form.

U.S.PatentNumbers:#6,912,495B2,#6,199,037B1,#5,870,405,#5,826,222,#5,754,974,#5,701,390,
#5,715,365,#5,649,050,#5,630,011,#5,581,656,#5,517,511,#5,491,772,#5,247,579,#5,226,084and
#5,195,166.

Disclaimer

Hytera endeavors to achieve the accuracy and completeness of this manual, but no warranty of accuracy or reliability is given. All the specifications and designs are subject to change without notice due to continuous technology development. No part of this manual may be copied, modified, translated, or distributed in any manner without the express written permission of Hytera.If you have any suggestions or would like to learn mo redetails, please visit our website at: <http://www.hytera.cn>.

RF Energy Exposure Compliance

- Your radio is designed and tested to comply with a number of national and international standards and guidelines (listed below) regarding human exposure to radio frequency electromagnetic energy. This radio complies with the IEEE and ICNIRP exposure limits for occupational/controlled RF exposure environment at operating duty factors of up to 50% transmitting and is authorized by the FCC for occupational use only. In terms of measuring RF energy for compliance with the FCC exposure guidelines, your radio radiates measurable RF energy only while it is transmitting (during talking), not when it is receiving (listening) or in standby mode.
- The device complies with SAR and/or RF field strength limits of RSS-102 requirement and contact information where the user can obtain Canadian information on RF exposure and compliance.

Your radio complies with the following of RF energy exposure standards and guidelines

- United States Federal Communications Commission, Code of Federal Regulations; 47CFR part 2 sub-part J
- American National Standards Institute (ANSI)/Institute of Electrical and Electronic Engineers (IEEE) C95. 1-1992
- Institute of Electrical and Electronic Engineers (IEEE) C95. 1-1999 Edition
- International Commission on Non-Ionizing Radiation Protection (ICNIRP) 1998

Operational Instructions and Training Guidelines

- To ensure optimal performance and compliance with the occupational/controlled environment RF energy exposure limits in the above standards and guidelines, users should transmit no

more than 50% of the time and always adhere to the following procedures:

- Gain of antenna must not exceed 6.5dBi.
- Antenna Installation: Install the mobile antenna at least 350 cm away from your body, in accordance with the requirements of the antenna manufacturer/supplier.

Transmit and Receive

To transmit (talk), push the Push-To-Talk (PTT) key; to receive, release the PTT key.

EU Regulatory Conformance

The equipment is in compliance with the essential requirements and other relevant provisions of the Directive 1999/5/EC.

CE 0678 



Note: The above information is applicable to EU countries only.

FCC Licensing Information

Part 15 Compliance

This equipment has been tested and found to comply with the limits for a Class B digital device, pursuant to part 15 of the FCC Rules. These limits are designed to provide reasonable protection against harmful interference in a residential installation. This equipment generates, uses and can radiate radio frequency energy and, if not installed and used in accordance with the instructions, may cause harmful interference to radio communications. However, there is no guarantee that interference will not occur in a particular installation. If this equipment does cause harmful interference to radio or television reception, which can be determined by turning the equipment off and on, the user is encouraged to try to correct the interference by one or more of the following measures:

- ✚ Reorient or relocate the receiving antenna.
- ✚ Increase the separation between the equipment and receiver.
- ✚ Connect the equipment into an outlet on a circuit different from that to which the receiver is connected.
- ✚ Consult the dealer or an experienced radio/TV technician for help.

FCC Licensing Requirements

A license from Federal Communications Commission is required prior to use. Your dealer will program each radio with your authorized frequencies, signaling codes, etc., and will be there to meet your communications needs as your system expands. Contact your dealer for more information.

Contents

Checking Items in the Package	5
Product Overview	6
Front Panel	6
Programmable Keys	6
Rear Panel.....	7
Internal Layout.....	8
Installation Guide	8
Installation Requirements.....	8
Before Installation.....	9
Installation Steps	9
Installation Diagram.....	11
After-installation Verification	12
Status Indication.....	12
LCD Icon.....	12
LED Indicator.....	13
Basic Operations.....	14
Turning the Repeater On/Off.....	14
Adjusting Volume.....	14
Adjusting Power Level	14
Backlight.....	14
Locking/Unlocking the Repeater	15
Menu Navigation.....	15
Radio Info	15
Channel Info	16
Exit.....	16
Alarm Information	16
Over Temperature Alarm	16
Fan Failure Alarm.....	17
VSWR Alarm.....	18
Low Forward Power Alarm	19
Over/Low Voltage Alarm.....	19
Troubleshooting	21
Care and Cleaning.....	22
Optional Accessories	23

Checking Items in the Package

Please unpack carefully and check that all items listed below are received. If any item is missing or damaged, please contact your dealer.

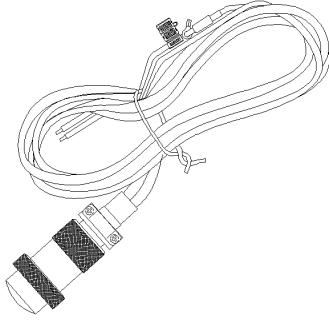

Power Cord

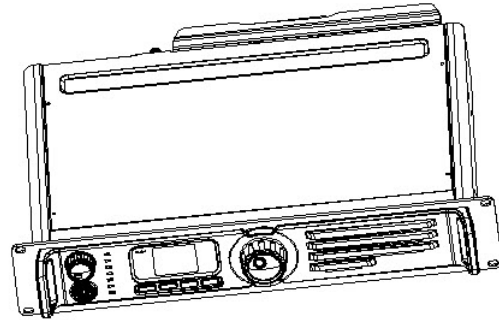

Repeater

Owner's Manual

Safety Information Booklet

Product Overview

Front Panel

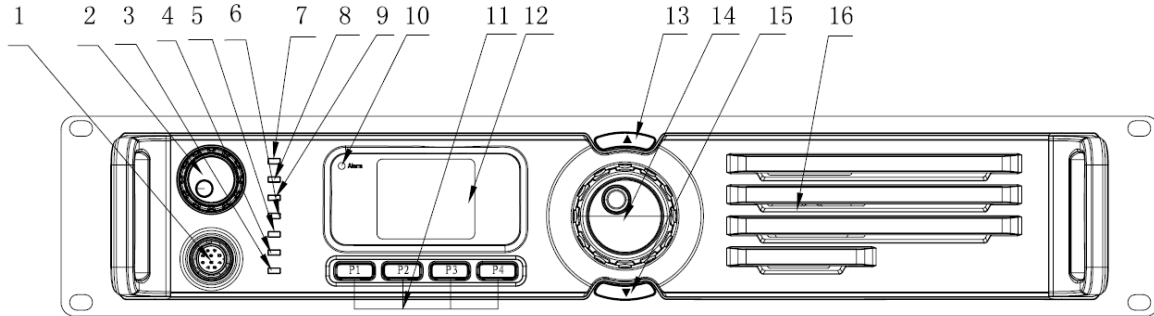

No.	Part Name	No.	Part Name
①	Accessory Jack	②	Volume Control Knob / Power Indicator
③	Repeater Mode Indicator	④	Analog Mode Indicator
⑤	Slot 2 RX Indicator	⑥	Slot 2 TX Indicator
⑦	Digital Mode Indicator	⑧	Slot 1 TX Indicator
⑨	Slot 1 RX Indicator	⑩	Alarm Indicator
⑪	Programmable Key *	⑫	LCD Display
⑬	Channel Up (CH+) *	⑭	Navigation Knob
⑮	Channel Down (CH-) *	⑯	Speaker

Programmable Keys *

For enhanced convenience, you can request your dealer to program the keys **P1**, **P2**, **P3** and **P4** as shortcuts to appropriate functions.

Rear Panel

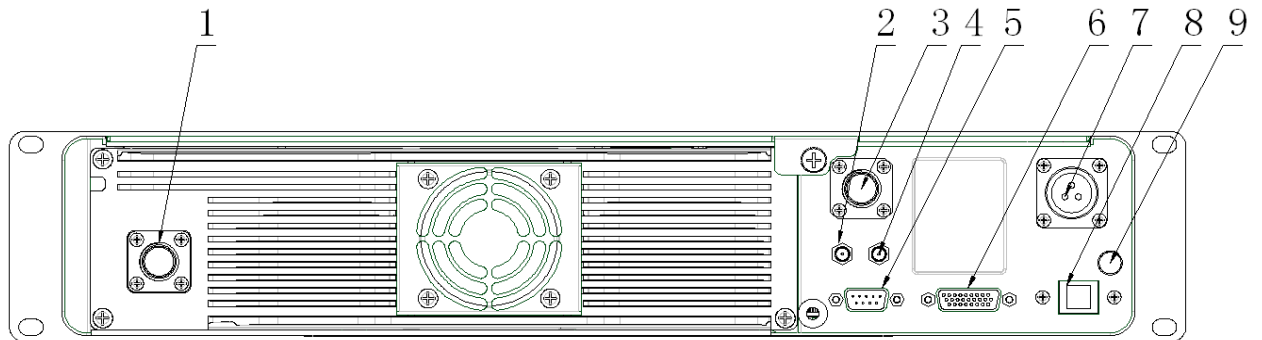

No.	Part Name	No.	Part Name
①	TX Antenna Interface	②	Optional Interface 1
③	RX/Duplex Antenna Interface	④	Optional Interface 2
⑤	Monitor/Tuning Interface	⑥	Accessory Jack
⑦	DC Power Interface	⑧	Ethernet Port *
⑨	Ground Screw		

Internal Layout

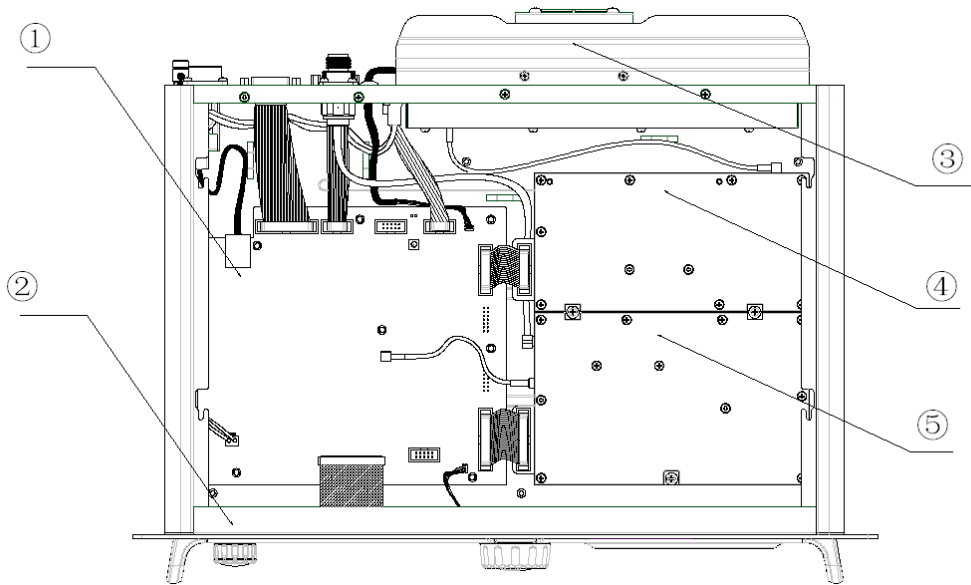

No.	Part Name	No.	Part Name
①	Baseband Module	②	Front Panel
③	PA Module	④	Excitor Module
⑤	RX Module		

Installation Guide

Proper installation can ensure optimum performance and reliability of the repeater.

Therefore, be sure to read the following instructions before installation.

Installation Requirements

1. Installation Environment

The repeater must be installed in a dry and well-ventilated place with ambient temperature of $-30^{\circ}\text{C} \sim +60^{\circ}\text{C}$ and relative humidity of less than 95%.

2. Installation Location

The repeater can be installed in a rack, bracket and cabinet or on a desk.

3. Installation Tool

Tools required for installing the repeater include a cross head screwdriver, a torx screwdriver and a spanner.



Note: please refer to **Safety Information Booklet** for more information.

Before Installation

1. Voltage Check

Please check whether the voltage of DC power or external battery meets the repeater specifications.

2. Product Check

Please check whether the repeater works properly by observing the 8 LEDs located on the front panel.

3. Parameter Configuration

When the repeater proves to work normally, configure appropriate parameters according to your actual requirements. And then you can proceed with on-site installation.

Installation Steps

Install the repeater as follows:

1. Install the repeater at a proper location;
2. Attach all necessary accessories;
3. Ground the repeater through the Ground Screw located on the rear panel.



Note: if the repeater needs to work with a duplexer, you should implement the following operations before installation.

1. Loosen the three screws on the bracket with a cross head screwdriver.

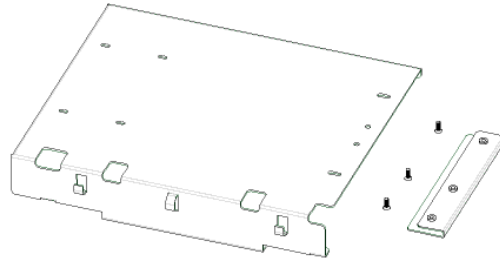

2. Install the duplexer onto the bracket. Be sure to observe the specifications of two antenna interfaces on the duplexer, to determine which one should be connected to the transmitter. The interface connecting the transmitter should be close to PA module to reduce RF loss, as shown below:

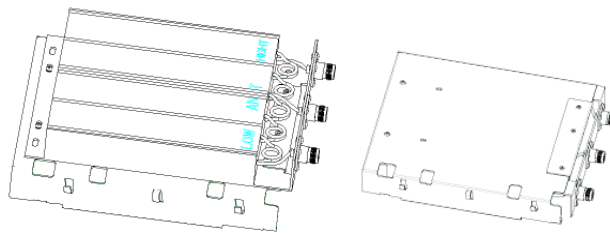

3. Loosen the screw at the back of the top cover, and then pull the top cover to remove it.

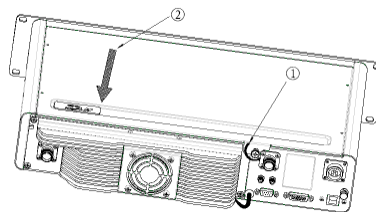

4. Loosen the 6 screws locking the PA heat sink, disconnect all power, data and RF cables, and finally remove the heat sink.

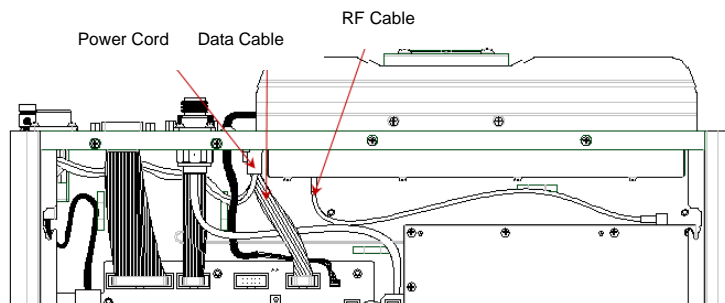

5. Connect the RF cable, as shown below.

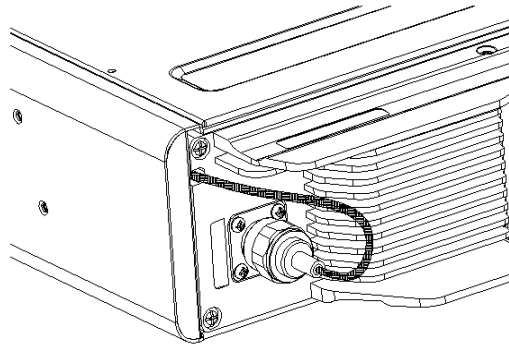

6. After the duplexer is mounted properly, fasten it with the 2 screws inside the housing and on the side respectively. Then attach the PA heat sink and connect all cables.

Installation Diagram

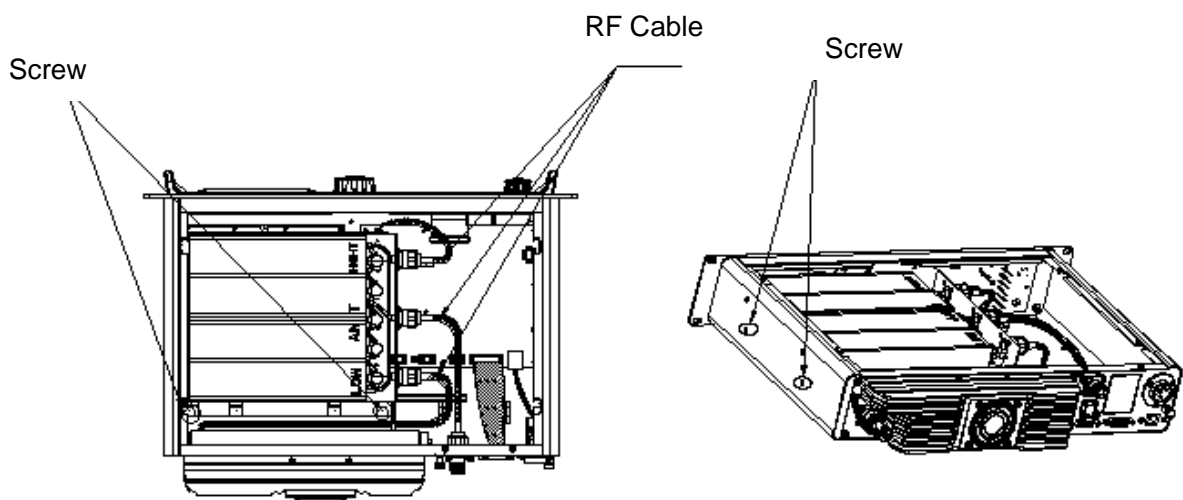

Duplexer with Front Side Facing Upwards

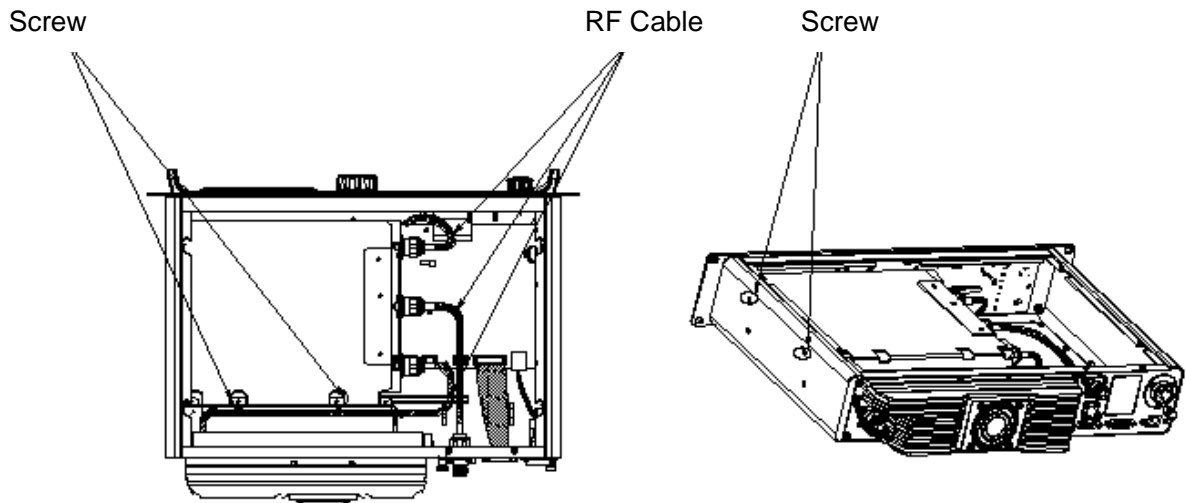

Duplexer with Front Side Facing Downwards

After-installation Verification





After installation is completed, power it on and verify whether it works properly by observing the 8 LEDs located on the front panel.

Status Indication

LCD Icon

These icons may appear on LCD. They can help you easily identify the repeater status.

Icon Name	Icon	Repeater Status
RSSI Indicator		More bars indicate better signal strength; *
TX Power Indicator		Low TX power for the current channel;
		High TX power for the current channel;
Scan Indicator		Scan is in progress; *
Monitor Indicator		The feature "Monitor" is active; *

Speaker Indicator		The speaker is unmuted; *
Alarm Indicator		An alarm message appears; *
Operation Mode Indicator		The repeater is operating in DMO mode; *
		The repeater is operating in TMO mode; *
		The repeater is operating in Repeat mode; *

LED Indicator

LED Indicator	Repeater Status
Power indicator (②) glows green.	Normal power-on
Alarm indicator (⑩) glows red.	The repeater works abnormally
Repeater mode indicator (③) glows green	The repeater is operating in Repeat mode
Repeater mode indicator (③) goes out.	The repeater is operating in Base mode
Slot 1 TX indicator (⑧) glows red.	Repeater is transmitting on an analog channel or on slot 1
Slot 1 TX indicator (⑧) flashes red.	Busy channel lockout * / transmission time-out *
Slot 2 TX indicator (⑥) glows red.	Repeater is transmitting on slot 2
Slot 2 TX indicator (⑥) flashes red.	Busy channel lockout * / transmission time-out *
Slot 1 RX Indicator (⑨) glows green.	Repeater is receiving on an analog channel or on slot 1
Slot 1 RX indicator (⑨) flashes green.	The feature "Monitor" is enabled *
Slot 2 RX Indicator (⑤) glows green.	Repeater is receiving on slot 2
Analog mode indicator (④) glows yellow.	The repeater is operating in Analog mode
Digital mode indicator (⑦) glows blue.	The repeater is operating in Digital mode

Basic Operations

Turning the Repeater On/Off

ON: turn on the repeater by connecting a DC power supply to it. During power-up process, the Power indicator glows green and the LCD shows animation.

OFF: Disconnect the DC power supply.



Adjusting Volume

In analog mode: rotate the **Volume Control** knob clockwise to increase the volume or counter-clockwise to decrease the volume.

In digital mode: the speaker is muted, so this knob does not work.

Adjusting Power Level

You may request your dealer to set the TX power to High or Low. High power can extend repeater coverage, enabling you to communicate with farther terminals. The TX power is

represented by the icon  and  respectively on the LCD.

Backlight

Activating the backlight can illuminate the LCD and all the front panel keys, so as to facilitate your operation.

You dealer can set the backlight to operate in any of the following modes:

- **Timed:** either key press or knob operation can activate the backlight. If no foregoing event occurs within the specified time period, the backlight will go out automatically.
- **Enable:** the backlight remains activated all the time.

 **Note:** When an alarm event occurs, the backlight will remain activated until the alarm disappears.

Locking/Unlocking the Repeater

You can request your dealer to lock the knob and all keys on the front panel to prevent accidental operation. To unlock, the repeater must be re-programmed by your dealer.

Menu Navigation

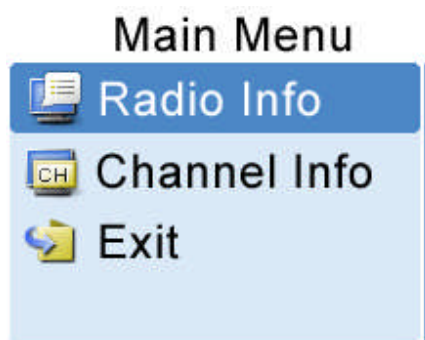

Radio Info

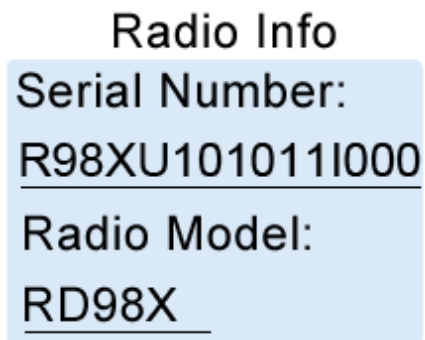

Under this menu, you can rotate the **Navigation** knob to view product information, including Serial Number, Radio Model, Freq Range and Firmware Ver.

◆To access this menu:

1. In the home screen, press the **Navigation** knob to enter the main menu.
2. Rotate the knob to select the "Radio Info" option.
3. Press the knob again to view basic information of the repeater.

◆To exit this menu:

Just press the knob again.

Channel Info

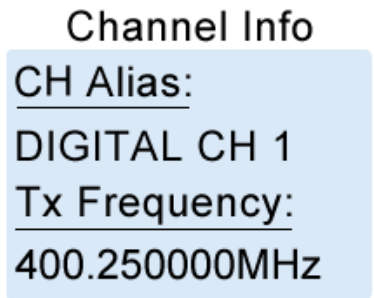

Under this menu, you can rotate the **Navigation** knob to view channel information, including CH Alias, Tx Frequency, and so on.

◆To access this menu:

1. In the home screen, press the **Navigation** knob to enter the main menu.
2. Rotate the knob to select the "Channel Info" option.
3. Press the knob again to view information of the current channel.

◆To exit this menu:

Just press the knob again.

Exit

To exit from the main menu, rotate the **Navigation** knob to select the "Exit" option, and then press the knob.

Alarm Information

The repeater can automatically detect its operation status in a real time way. When an abnormality occurs, the LCD will give you a prompt message, and the Alarm Indicator will glow red.

Over Temperature Alarm

When the temperature of PA module exceeds the normal range, the Alarm Indicator will

glow red and the LCD will display the prompt message below:

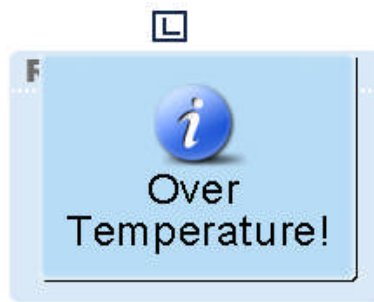

Then the repeater will stop transmitting, and you need to:

1. Check whether the temperature of heat sink surface is over 80°C. If yes, proceed with Step 2 and 3 to find out the cause.

 **Caution:** DO NOT touch the heat sink surface to avoid burn. You can use a digital thermometer with thermocouple to measure the temperature value.

2. Check whether ambient temperature and ventilation conditions satisfy the foregoing installation requirements. If not, please make improvements as soon as possible.
3. Check if connection between the transmitter and RF cable or antenna feeder is loose or damaged. Poor connection between them could cause high TX power, which would make the temperature of heat sink rise quickly. If yes, secure or replace the cable or antenna feeder.
4. If the above measures fail to solve the problem, contact your local dealer for technical support.

When temperature falls into normal range, the prompt message will disappear, and the Alarm Indicator will go out.

Fan Failure Alarm

When the fan fails to work, the Alarm Indicator will glow red and the LCD will display the prompt message below:

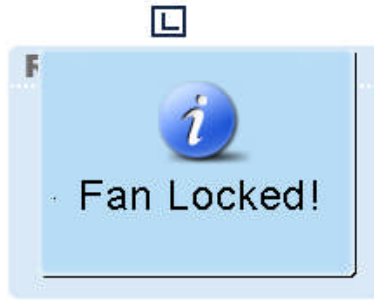

Then the repeater will automatically work at low TX power, to protect the transmitter from overheating. You need to:

1. Check whether the fan is blocked by an object. If yes, remove it.
2. If you cannot solve the problem, contact your local dealer for technical support.

When the fan recovers normal operation, the prompt message will disappear, and the Alarm Indicator will go out.

VSWR Alarm

High VSWR (voltage standing wave ratio) of TX antenna connector could result in damage to the PA, and even failure of the transmitter. When the VSWR exceeds the normal range, the Alarm Indicator will glow red and the LCD will display the prompt message below:



Then the repeater will automatically works at low TX power. You need to:

1. Check if the operating frequency of repeater is in line with that of antenna. Both frequency mismatch and improper antenna could result in poor transmitting performance and even damage to the transmitter. If yes, please contact your local dealer to replace the antenna or reprogram your product.

2. Check if the connection between the transmitter and RF cable or antenna feeder is loose or damaged. If yes, secure or replace the cable or antenna feeder.
3. If you cannot solve the problem, contact your local dealer for technical support.

When the VSWR falls within the normal range, the prompt message will disappear, and the Alarm Indicator will go out.

Low Forward Power Alarm

When the forward power is below the preset value, the Alarm Indicator will glow red and the LCD will display the prompt message below:



Then the repeater may continue transmission or terminate it, subject to the detection result. You need to:

1. Check if the connection between the transmitter and RF cable or antenna feeder is loose or damaged. If yes, secure or replace the cable or antenna feeder.
2. If you cannot solve the problem, contact your local dealer for technical support.

When the forward power is recovered to its normal value, the prompt message will disappear, and the Alarm Indicator will go out.

Over/Low Voltage Alarm

When power voltage is detected to be over or below the normal range (11V-15.6V) of repeater, the Alarm Indicator will glow red and the LCD will display the prompt message below:

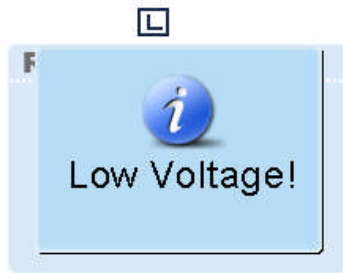

Low Voltage Alarm

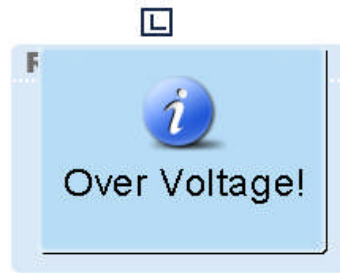

Over Voltage Alarm

Then the repeater will automatically stop working. You need to:

1. Check whether the power voltage is too low or too high. If yes, replace the DC power supply or external battery.
2. Check whether the power cord is loose or damaged. If yes, secure or replace the cord.
3. If you cannot solve the problem, contact your local dealer for technical support.

When the voltage falls within the normal range, the prompt message will disappear, and the Alarm Indicator will go out.

 **Caution:** If low voltage is detected when the repeater is powered by an external battery, please charge it in time. Disconnect the battery from the repeater before charging.

Troubleshooting

Phenomena	Analysis	Solution
The repeater cannot be powered on.	<ul style="list-style-type: none"> a. Power cord is not connected or is not securely connected to the outlet. b. Power cord fuse is damaged. 	<ul style="list-style-type: none"> a. Properly connect the power cord and ensure secure connection. b. Check if the fuse has blown. If yes, replace it with a new one.
Group members cannot talk to each other, or the repeater cannot communicate with a subscriber radio.	<ul style="list-style-type: none"> a. TX/RX frequency of the repeater is inconsistent with that of portable/mobile terminals. b. Failed to repeat useful signal due to strong interference signal. c. The group member is out of the coverage of the repeater. 	<ul style="list-style-type: none"> a. Re-set frequencies. b. If you cannot remove or bypass the interference source, change to operate at other frequencies. c. Go within the coverage of the repeater.
Group members cannot talk to each other, even though RX indication is given.	<ul style="list-style-type: none"> a. Your ID is inconsistent with that of other group members. b. Inconsistent CTCSS/CDCSS. 	<ul style="list-style-type: none"> a. Set your ID to the same as that of other members. b. Re-set CTCSS/CDCSS.
Short communication range or poor audio	<ul style="list-style-type: none"> a. Leakage of signal energy due to damaged connection cable. b. Loose connection between the antenna 	<ul style="list-style-type: none"> a. Replace the cable with a new one if necessary. b. Secure or replace the cable. c. Replace the cable with a new one. d. Contact the manufacturer or your

	<p>connector and the cable, or loss of connection</p> <p>c. Invisible damage of cable.</p> <p>d. Duplexer is not properly set (if the duplexer is mounted).</p>	dealer to re-set the duplexer.
--	--	---------------------------------------

If the above solutions can not fix your problems, or you may have some other queries, please contact us or your local dealer for more technical support.

Care and Cleaning

To guarantee optimal performance as well as a long service life of the product, please follow the tips below. Power off the repeater or disconnect it from the external battery before cleaning.

Product Care

- Keep the product at a place of good ventilation and heat dissipation to facilitate normal work.
- Do not place irrelevant articles on top of the product to ensure optimal heat dissipation.
- Do not pierce or scrape the product with any edged instruments or hard objects.
- Keep the product far away from substances that can corrode the circuit.
- Do not place the product in corrosive agents, solutions or water.

Product Cleaning

- Remove the dust and fine particles on the repeater surface with a clean and dry lint-free cloth or a brush regularly.
- Use a non-woven cloth with neutral cleanser to clean the keys, control knobs, LCD and jacks after long-time use. Never use chemical preparations such as stain

removers, alcohol, sprays or oil preparations. Make sure the product is completely dry before use.

Optional Accessories

The following items are the main optional accessories for the product, and please consult your local dealer for more information.

			
<p>Palm Microphone SM16A1 *</p>	<p>Desktop Microphone SM10A1 *</p>	<p>External Power Supply (320W, backup battery applicable) PS22002</p>	<p>Programming Cable (USB Port) PC37</p>
			
<p>Omni-directional Antenna</p>	<p>Directional Antenna</p>		<p>Duplexer Bracket/Screws (for DT11/DT12 only)</p>

 **Caution:** Use the accessories specified by Hytera only. If not, Hytera shall not be liable for any losses or damages arising out of use of unauthorized accessories.