

ATTACHMENT E. USERS MANUAL

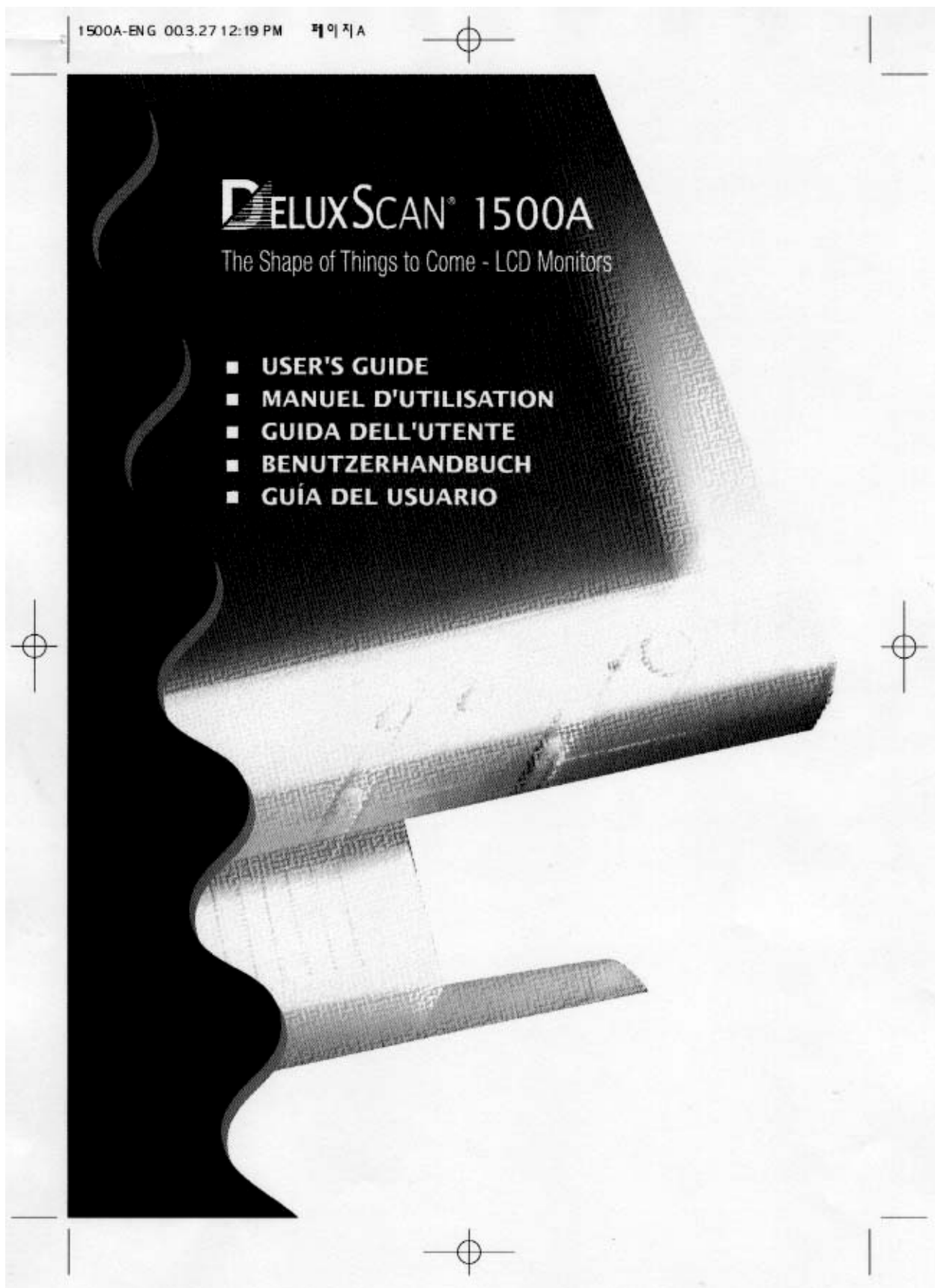

1500A-ENG 00.3.27 12:19 PM 페이지 A

DELUXSCAN[®] 1500A

The Shape of Things to Come - LCD Monitors

- USER'S GUIDE
- MANUEL D'UTILISATION
- GUIDA DELL'UTENTE
- BENUTZERHANDBUCH
- GUÍA DEL USUARIO

1500A-ENG 00.3.27 12:17 PM

하이씨피



DECLARATION OF CONFORMITY

WE HYUNDAI ELECTRONICS INDUSTRIES CO., LTD.
Ami-ri Bubal-Eub Ichon-Si Kyungki-Do
467-860 KOREA

declare under our sole responsibility that the product:

Kind of equipment : COLOR MONITOR

Type-Designation : HLM 1500A

to which this declaration relates is in conformity with the
following standard(s) or other normative document(s)

Safety : EN60950 : 1992 + A1, A2, A3, A4
EMC : EN 55 022/1994, EN 50 082-1/1992
IEC 801-2/1991, IEC 801-3/1984, IEC 801-4/1988

following the provisions of the Low Voltage Directive 73/23/EEC,
93/68/EEC and the EMC Directive 89/336/EEC.

Accredited testlaboratory:
TÜV Rheinland
Am Grauen Stein
51105 Köln

KOREA /NOV. 13, 1998
(Place and date of issue)

HONG KI, KIM
(Name and signature of
authorized person)



1500A-ENG 003.27 11:27 AM

페이지 C

U.S.A.

**U.S.FEDERAL COMMUNICATIONS COMMISSION
RADIO FREQUENCY INTERFERENCE STATEMENT
INFORMATION TO THE USER**

NOTE : This equipment has been tested and found to comply with the limits for a Class B digital device pursuant to Part 15 of the FCC Rules.

These limits are designed to provide reasonable protection against harmful interference in a residential installation.

This equipment generates, uses, and can radiate radio frequency energy and, if not installed and used in accordance with the instructions, may cause harmful interference to radio communications.

However, there is no guarantee that interference will not occur in a particular installation.

If this equipment does cause harmful interference to radio or television reception, which can be determined by turning the equipment off and on, the user is encouraged to try to correct the interference by one or more of the following measures:

- Reorient or relocate the receiving antenna.
- Increase the separation between the equipment and receiver.
- Connect the equipment into an outlet of a circuit different from that to which the receiver is connected.
- Consult the dealer or an experienced radio/TV technician for assistance.

Changes or modification not expressly approved by the party responsible for compliance could void the user's authority to operate the equipment.
Connecting of peripherals requires the use of grounded, shielded signal cables.

TCO '99

Congratulations! You have just purchased a TCO '99 approved and labelled product! Your choice has provided you with a product developed for professional use. Your purchase has also contributed to reducing the burden on the environment and also, to the further development of environmentally adapted electronics products.



Why do we have environmentally labelled computers?

In many countries, environmental labelling has become an established method for encouraging the adaptation of goods and services to the environment. The main problem, as far as computers and other electronics equipment are concerned, is that environmentally harmful substances are used both in the products and during the manufacturing. Since it has not been possible for the majority of electronics equipment to be recycled in a satisfactory way, most of these potentially damaging substances sooner or later enter Nature.

There are also other characteristics of a computer, such as energy consumption levels, that are important from the viewpoints of both the work(internal) and natural(external) environments. Since all methods of conventional electricity generation have a negative effect on the environment(acidic and climate-influencing emissions, radioactive waste, etc.), it is vital to conserve energy. Electronics equipment in offices consume an enormous amount of energy since they are often left running continuously.

What does labelling involve?

This product meets the requirements for the TCO '99 scheme which provides for international and environmental labelling of personal computers. The labelling scheme was developed as a joint effort by the TCO (The Swedish Confederation of Professional Employees), Naturskyddsforeningen (The Swedish Society for Nature Conservation) and NUTEK (The National Board for Industrial and Technical Development in Sweden). The requirements cover a wide range of issues: environment, ergonomics, usability, emission of electrical and magnetic fields, energy consumption and electrical and fire safety. The environmental demands concern restrictions on the presence and use of heavy metals, brominated and chlorinated flame retardants, CFCs (freons) and chlorinated solvents, among other things. The product must be prepared for recycling and the manufacturer is obliged to have an environmental plan which must be adhered to in each country where the company implements its operational policy. The energy requirements include a demand that the computer and/or display, after a certain period of inactivity, shall reduce its power consumption to a lower level in one or more stages. The length of time to reactivate the computer shall be reasonable for the user. Labelled products must meet strict environmental demands, for example, in respect of the reduction of electric and magnetic fields, physical and visual ergonomics and good usability.

On the back page of this folder, you will find a brief summary of the environmental requirements met by this product. The complete environmental criteria document may be ordered from:

TCO Development Unit
S-114 94 Stockholm
Sweden
Fax: +46 8 782 92 07
Email (Internet) : development @ tco.se

1500A-ENG 00.3.27 11:44 AM

페이지 E

Current information regarding TCO '99 approved and labelled products may also be obtained via the Internet, using the address:

<http://www.tco-info.com/>

TCO '99 is a co-operative project between TCO (The Swedish Confederation of Professional Employees), Naturskyddsforeningen (The Swedish Society for Nature Conservation) and NUTEK (The National Board for Industrial and Technical Development in Sweden).

Environmental Requirements

Brominated flame retardants

Brominated flame retardants are present in printed wiring boards, cables, wires, casings and housings. In turn, they delay the spread of fire. Up to thirty percent of the plastic in a computer casing can consist of flame retardant substances. These are related to another group of environmental toxins, PWBs, which are suspected to give rise to similar harm, including reproductive damage in fish eating birds and mammals, due to the bio-accumulative processes. Flame retardants have been found in human blood and researchers fear that disturbances in foetus development may occur.

TCO '99 demand requires that plastic components weighing more than 25 grams must not contain organically bound chlorine and bromine.

Lead**

Lead can be found in picture tubes, display screens; solders and capacitors. Lead damages the nervous system and in higher doses, causes lead poisoning.

TCO '99 requirement permits the inclusion of lead since no replacement has yet been developed.

Cadmium**

Cadmium is present in rechargeable batteries and in the colour generating layers of certain computer displays. Cadmium damages the nervous system and is toxic in high doses.

TCO '99 requirement states that batteries may not contain more than 25 ppm (parts per million) of cadmium. The colour-generating layers of display screens must not contain any cadmium.

Mercury**

Mercury is sometimes found in batteries, relays and switches. Mercury damages the nervous system and is toxic in high doses.

TCO '99 requirement states that batteries may not contain more than 25 ppm (parts per million) of mercury. It also demands that no mercury is present in any of the electrical or electronics components concerned with the display unit.

CFCs (freons)

CFCs (freons) are sometimes used for washing printed circuit boards and in the manufacturing of expanded foam for packaging. CFCs break down ozone and thereby damage the ozone layer in the stratosphere, causing increased reception on Earth of ultraviolet light with consequent increased risks of skin cancer (malignant melanoma).

The relevant TCO '99 requirement: Neither CFCs nor HCFCs may be used during the manufacturing of the product or its packaging.

* Bio-accumulative is defined as substances which accumulate within living organisms

** Lead, Cadmium and Mercury are heavy metals which are Bio-accumulative.

ENGLISH

Table of Contents

How to get the most enjoyment with this monitor ----- 1

 Features ----- 1

 General safety precautions ----- 1

 Maintenance ----- 2

Packing list ----- 2

Connecting with external equipment ----- 3

 Cautions----- 3

Microcontroller features ----- 4

 Display mode memory ----- 4

 User-setting area ----- 4

 Factory-presetting area ----- 4

 Automatic save ----- 4

 DDC 1/2B (Display Data Channel 1/2B) ----- 4

On screen controls & LED indicator ----- 5

 On-screen display settings ----- 6

 Refining the picture ----- 7

 Adjust sequence ----- 8

Preset mode chart ----- 10

 Timing charts ----- 10

 Input timing limits ----- 10

 Input level limits ----- 10

 Preset mode table ----- 11

Power management ----- 12

 Operation ----- 12

Video input terminal ----- 13

 15 Pin D-Sub Connector ----- 13

Specifications----- 14



How to get the most out of this monitor

This is a 15" color LCD monitor (Model: HLM 1500A) which can display signals from a personal or micro computer.
 This manual has been prepared to familiarize you with your new display monitor.

Features

- 15" viewable XGA (1024×768) resolution LCD module
- 16.7 Mil Colors
- DPMS (Display Power Management Signaling)
- OSD (On-Screen Display) controls, multi-language OSD Menu
- Automatically adjust the image Position, the Clock, the Clock Phase settings
- Universal 100-240V AC power supply
- DDC 1/2B features

ENGLISH

General safety precautions

This Monitor has been engineered and manufactured to assure your safety. You can prevent serious electrical shock and other hazards by keeping in mind the following:



Do not place anything heavy, wet or magnetic on the monitor or the power cord. Never cover the ventilation openings with any material and never touch them with metallic or inflammable materials.

Avoid operating the monitor in extreme heat, humidity or areas affected by dust.
 Temperature : 5 ~ 35°C
 Humidity : 30 ~ 80RH



Be sure to turn the monitor off before plugging the power cord into the socket.
 Make sure that the power cord and the other cords are securely and rightly connected.

Overloaded AC outlets and extension cords are dangerous, as are frayed power cords and broken plugs, which may cause electric shock or fire.
 Call your service technician for replacement.



LCD 1500A User's Guide

ENGLISH



Do not use sharp tools such as a pin or a pencil near the monitor, as they may scratch the LCD surface.

Do not use a solvent, such as benzene, to clean the monitor, as it will damage the LCD surface.



Maintenance



Do not open the monitor. There are no user-serviceable components inside, and there is a risk of exposure to high-voltage electricity inside, even when power is turned off. If the display monitor does not operate properly, remove the power cord from the wall outlet and contact your dealer. As with any electrical equipment, careless use and unprofessional maintenance are liable to cause a serious electric shock and other hazards.

Packing List



HLM 1500A LCD Monitor



Signal Cable



Power Cord



User's Guide



Above power cord can be changed upon different voltage areas.



Connecting with external equipment

Caution

Be sure to turn off the power of your computer before connecting the monitor.

ENGLISH

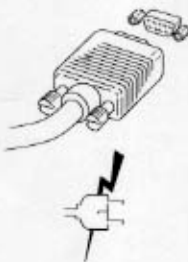
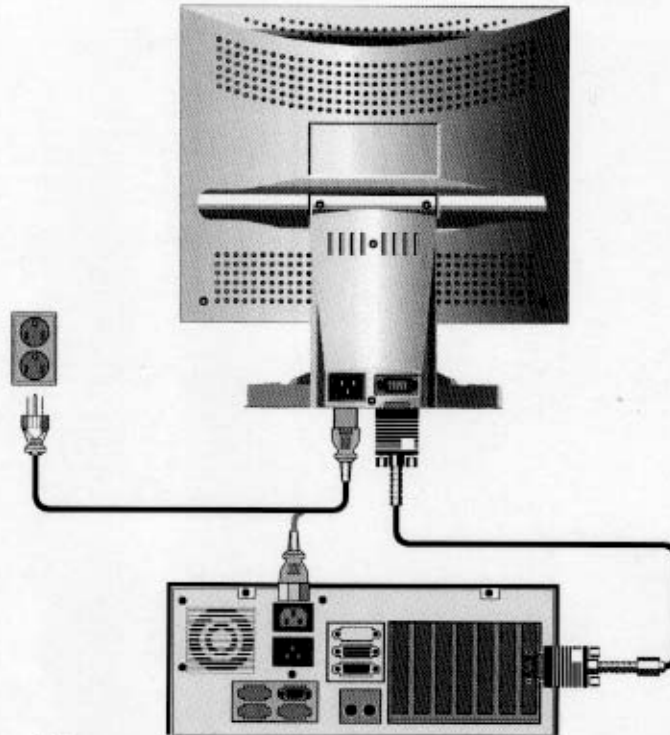

Connect the video signal cable (15-pin connector) to the connector on the video board inside the computer, usually located on the rear panel of the computer.

Connect the power supply cable to the monitor and then to the power supply.

After powering on the computer, wait for 30 seconds, then adjust the display using the various controls provided (see later). For further information on the installation procedure, refer to the operating guide of the computer being used.

LCD 1500A User's Guide

ENGLISH

Micro-controller features

The micro-controller automatically detects the video board installed in your system. When you turn on the monitor, the micro-controller first checks the display-mode memory stored in the user-setting area and the factory-presetting area.

Display-mode memory

The micro-controller has the memory capacity to store 29 different display modes including timing formats and display settings. This memory capacity is divided into two parts. One is the user-setting area, and the other is the factory-presetting area.

User-setting area

The user can add nonstandard modes. If you adjust your display image, the image is saved automatically. The micro-controller will then always detect and display the last mode stored in the user-setting area when the monitor is turned on.

The user-setting area maintains the last 10 display modes set by the user in its memory. When the user-setting area is full (i.e. when 10 modes are registered), the oldest timing settings will be deleted as new ones are added.

Factory-presetting area

There are 19 display modes stored in this area. These display modes are preset at the factory and include most of the display modes currently available (see Preset-mode table in this manual).

You can also retrieve the factory-preset mode by selecting the RECALL menu.

Automatic save

The monitor automatically saves the setting value after certain times (5, 8, 12, 20, 30sec) of adjusting OSD menu.

DDC 1/2B (Display Data Channel 1/2B)

DDC 1/2B (Display Data Channel 1/2B) is a communication channel through which the monitor automatically informs the host system of its capabilities.

DDC 1/2B uses a formerly unconnected signal pins in the 15-pin VGA connector.

The system will perform as a "Plug & Play" feature if both monitor and host systems support DDC 1/2B protocol.

! Some computer systems are not compatible with the DDC 1/2B standard. If your monitor displays the wrong resolution, please check your computer system, including the DDC compatible video card.



On-screen controls and LED indicator

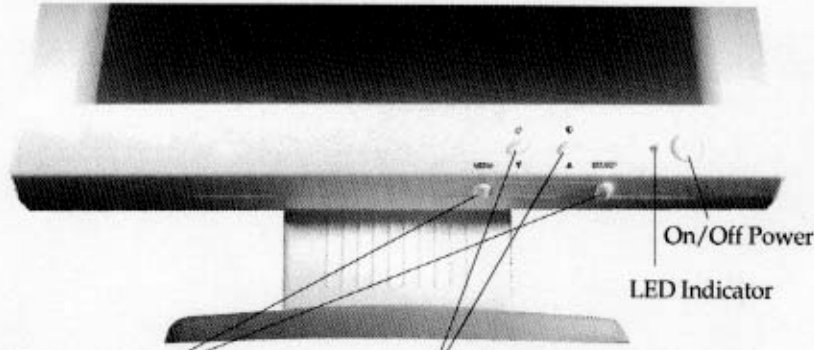

ENGLISH

- | | |
|-----------------------------------|---------------------------------------|
| Enable the each Sub menu | 1) Choose the sub-menu |
| 1) Enable the OSD Menu | 2) Adjust the value of each menu |
| 2) Return to higher level of menu | 3) Adjust Contrast/Bright with pop-up |

Main menu and control selection

Press the MENU and select key to access the main menu. The resolution and frequency are displayed at the top of the menu box. When a nonstandard signal is detected, the frequency is also displayed. Place the color box on the control icon you wish to adjust by using the ▲ or ▼ key. Press the select key to access the control.

Exit menu

Press the MENU key to exit the OSD screen.

Auto exit

The OSD images disappear automatically after a few seconds of inactivity.

Auto save

The monitor automatically saves the new setting when OSD closes.

Normal mode

When the video signal is working in normal display mode, power LED is lit Green.

DPMS mode

The LED indicates different status when this unit operates in different power-saving modes.

Out of range

When an unsuitable signal is detected, the OSD displays an Out of Range message.





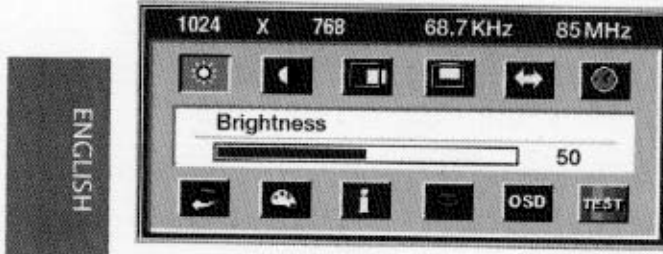







LCD 1500A User's Guide

On-screen display settings



The menu for screen setting adjustment is located in the OSD and can be viewed in one of nine languages. OSD feature and main Menu functions are as follows:

ENGLISH

-  **Brightness**
Adjust the screen's intensity.
-  **Contrast**
Adjusts the contrast of the screen image.
-  **H-Position**
Adjusts the horizontal position of the screen image.
-  **V-Position**
Adjusts the vertical center of the screen image.
-  **Clock**
Adjusts the width of the screen image.
-  **Clock-Phase**
Adjusts the noise of the screen image.
-  **Recall**
Reload the factory-preset mode.
-  **Color control**
Display the color control menu.
-  **Preset mode**
Display the factory-preset timing.
-  **Language**
Select from nine languages.
-  **OSD Adjust**
Displays the OSD position adjustment menu.
Select the OSD display timing.
-  **TEST**
Displays the TEST pattern.

! The Clock Phase may not be optimized in case VESA timing could not meet the standard. In order to get the optimized result of Auto Adjust function, please brighten the background image.

1500A-ENG 003.27 11:45 AM 페이지 7



DELUXSCAN™

Refining the picture

- Step 1. At first display, a full screen, such as Window background or "H" character should be achieved by using Editor (eq; notepad).
- Step 2. Adjust the screen to the center of the display (LCD) by using the top and bottom display controls (i.e. using V-Position Adjust menu).

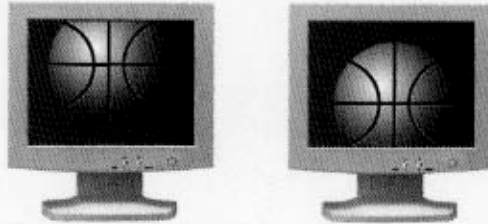

ENGLISH

- Step 3. Adjust the screen to the center of the Display (LCD) by using the right and left display controls (i.e. using Clock and H-Position adjust menu).



- Step 4. Adjust the Clock-Phase until the "H" Character displays clear.















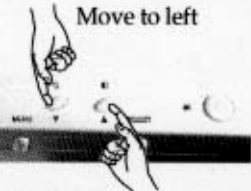

- Step 5. Using the Contrast, Brightness, and Color Control menu, set the color to your preference.
- Step 6. When you finish the adjustment, you can save your settings by pressing on the menu until the OSD screen has disappeared.

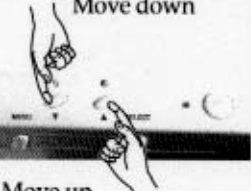

LCD 1500A User's Guide

Adjust Sequence

ENGLISH

How to enable the menu	Adjust method		
<p>Step1. Press the menu key to enable the OSD menu.</p>  <p>Step2. Press the ▼ (Down) / ▲ (Up) key to select the Menu icon.</p>  <p>Step3. Press the SEL key to enable the selected icon.</p> 	H-Position	<p>Move to left</p>  <p>Move to right</p> 	 
	V-Position	<p>Move down</p>  <p>Move up</p> 	 
	Clock	<p>Decrease the size</p>  <p>Increase the size</p> 	
	Clock Phase	<p>Decrease the phase delay</p>  <p>Increase the phase delay</p> 	



ENGLISH

How to enable the menu	Adjust method	
	Brightness/ Contrast	
	Color Control	<p>Select the color temperature</p>
	Auto Adjust	<p>Select the Auto Adjust</p>
	Recall	Reloads factory-preset mode
	Preset Mode	Shows the factory-preset timing
	Language	Selects from five different languages
Hot Key Function	Brightness	<p>Press the ▲ (Down) key to enable the brightness menu.</p> <p>Use the ▼ (Down) and ▲ (Up) key to adjust the brightness .</p>
	Contrast	<p>Press the ▲ (Up) key to enable the contrast menu</p> <p>Use the ▼ (Down) and ▲ (Up) key to adjust the contrast</p>

LCD 1500A User's Guide

Preset mode chart

Timing charts

Supported video timings;
This monitor shall be capable of displaying following video-timing charts.

ENGLISH

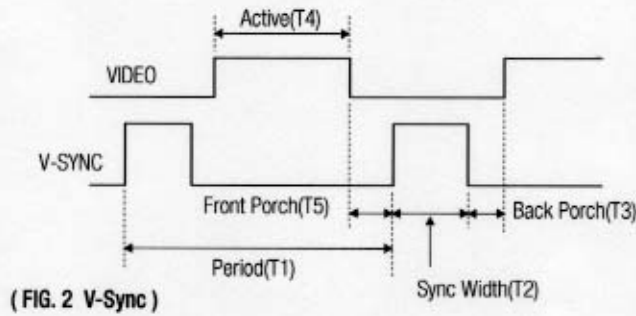
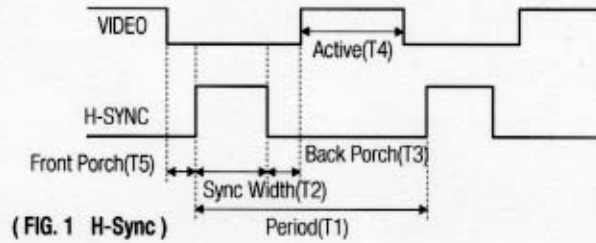

Input timing limits

H-sync pulse width $1.0\mu s \leq \text{sync pulse width} \leq 8.0\mu s$
V-sync pulse width $0.04\text{ms} \leq \text{sync pulse width} \leq 0.5\text{ms}$

! If the sync pulse width of input timing is out of range of input timing limits, monitor may operate abnormally. Be sure to check the input timing sync pulse width.

Input level limits

Low level: 0.4V max
High level: 2.4V min

LCD 1500A User's Guide

Power management

This monitor is equipped with a DPMS (Display Power Management Signaling) function that automatically cuts power use to just a little less than 8W when the computer is left unattended.

Although the monitor can be left in power-saving mode for longer periods, we recommend that you turn it off after your daily work.

Operation

The DPMS function requires support from the computer system for any software DPMS function applied. If the keyboard (or mouse) is left unattended for a certain period, the program or system will set the sync signals to DPMS mode.

The recommended signals, power consumption, and recovery times are shown in the table below.

Status	Signal			Power Consumption	Recovery Time	LED Indicator
	H Sync	V Sync	Video			
On	Pulse	Pulse	Active	40 Watt	-	Green
Standby	No Pulse	Pulse	Blank	Less than 15 Watt	Within 2 sec	Alternating Green/Orange (0.5sec)
Suspend	Pulse	No Pulse	Blank	Less than 10 Watt	Within 3 sec	Alternating Green/Orange(0.5sec)
Off	No Pulse	No Pulse	Blank	Less than 5 Watt	Within 3 sec	Orange



Video input terminal

A 15 pin D-sub connector is used as the input signal connector.
Pin and input signals are shown in the table below.

Pin Number	Signal Name
1	RED
2	GREEN
3	BLUE
4	GROUND
5	DDC-Return
6	RED-Ground
7	GREEN-Ground
8	BLUE-Ground
9	N.C.
10	Logic-Ground
11	Ground
12	SDA(DDC)
13	H-Sync
14	V-Sync
15	SCL(DDC)

ENGLISH

15 Pin D-Sub Connector

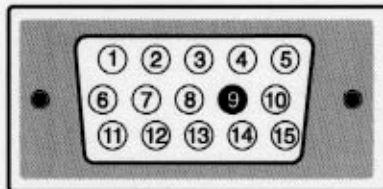

LCD 1500A User's Guide

Specifications

ENGLISH

LCD	Type	AM-TFT
	Size	15" viewable, Diagonal
	Dot Pitch	0.297 mm
	Brightness	200cd/m ² (Typ), 180cd/m ² (Min)
	Response Time	40msec Max.
Input	Signal	RGB Analog
	Type	15 pin D-sub
Sync	H-Freq	24.8 ~ 68.7kHz
	V-Freq	56 ~ 85Hz
Video Band Width		94.5MHz Max
Display	Area	304 × 228mm
	Color	16.7 Mil colors
Resolution (Max.)		1024 × 768 @ 85Hz
User Controls & OSD Controls		Contrast, Brightness, H/V Position, Clock, Clock-Phase, Recall, Preset Mode, Color Control, Language, OSD Adjust(Position, Display Time), Auto Adjust
Power Management		VESA DPMS Standard
Plug & Play		VESA DDC 1/2B
Safety & Regulation	Ergonomics	TCO'99
	EMC	FCC Class B, CE
	Safety	UL, cUL, CE, TÜV-GS, SEMKO, NEMKO, DEMKO, FIMKO
Temperature	Operating	5 to 35°C
	Storage	-5 to 45°C
Humidity	Operating	30% to 80% (Non-condensing)
	Storage	5% to 90% (Non-condensing)
Weight	Unit	4.6Kg
	Carton	6.5Kg
Dimension (W × H × D mm)		380 × 384 × 174 mm

☞ Specification is subject to change without notice for performance improvement.