 Hyundai Electronics Industries Co., Ltd.

Prepared by SW W. G. Park	Approved by CJ G. B. Kim	Doc No.	Rev Code 1.1	Page 1(26)
Controlled by FWT Team	Reviewed by GJ D. H. Joo	Date FEB 28, 2000	File/Ref	
Subject HWT-120 User Manual		Title		

# Fixed Wireless Terminal User's Manual

**Hyundai Electronics Industries Co., Ltd.**

**--- Table of Contents ---**

I.	Before the Use .....	3
1.1	Components.....	3
1.2	Name and function of each part.....	4
1.3	Cautions.....	6
II.	Installation .....	7
2.1	General installation.....	7
2.2	Wall bracket installation.....	11
2.3	Installation of external panel antenna (option).....	13
2.4	Installation for data service .....	14
III.	Basic Operation .....	15
3.1	Power on.....	15
3.2	Power off.....	15
3.3	To make a call.....	15
3.4	To answer a call.....	16
3.5	Analog G3 fax service.....	17
3.6	Data service.....	17
IV.	Additional Functions .....	19
4.1	Speed dial.....	19
4.2	Emergency call hold.....	20
4.3	Hot line.....	21
4.4	Alarm reminder.....	21
4.5	Lock.....	22
4.6	Earpiece volume control.....	
4.7	Reset to default values.....	
	Appendix .....	24
1.	Summary of Additional Functions (Summary Table) .....	24
2.	Technical Specification .....	25



## FCC RF EXPOSURE INFORMATION



In August 1996 the Federal Communications Commission (FCC) of the United States with its action in Report and Order FCC 96-326 adopted an updated safety standard for human exposure to radio frequency (RF) electromagnetic energy emitted by FCC regulated transmitters. Those guidelines are consistent with the safety standard previously set by both U.S. and international standards bodies. The design of this phone complies with the FCC guidelines and these international standards.



This device was tested for RF exposure compliance with the back of the phone kept 2.5 cm (1.0 inches) from the body. To comply with FCC RF exposure requirements, a minimum separation distance of 2.5 cm (1.0 inches) must be maintained between the user/bystander and the back of the phone, including the antenna.

*For more information about RF exposure, please visit the FCC website at [www.fcc.gov](http://www.fcc.gov)*

## I. Before the Use

The product is WLL terminal (Wireless Local Loop Terminal) designed based on CDMA, one of the most advanced communication technologies to fully satisfy your demands for improved communication services. Please, make sure to read throughout the manual before the use.

\* Notes: Before the use, please link the terminal to the backup battery, as they are not connected at the time of the delivery. You can refer to "2.1 General installation" of the manual.

### 1.1 Components

Thank you for purchasing this product. Please check whether your purchase includes each of the following contents.

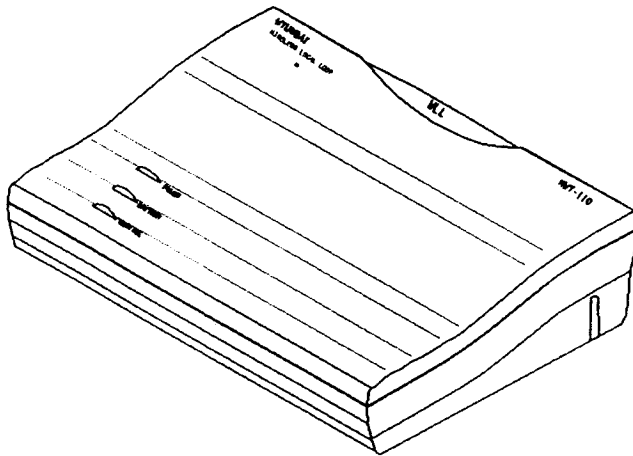

-WLL Terminal -

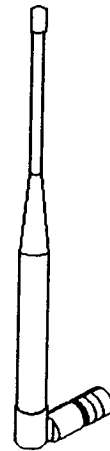

- Antenna -

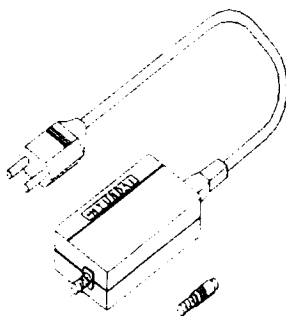

- Power Supply (SMPS) -

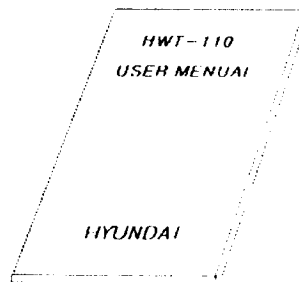

- User Manual -

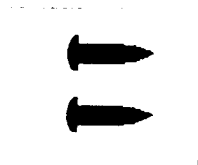

- Screw - (Options)



## 1.2 Name and function of each part

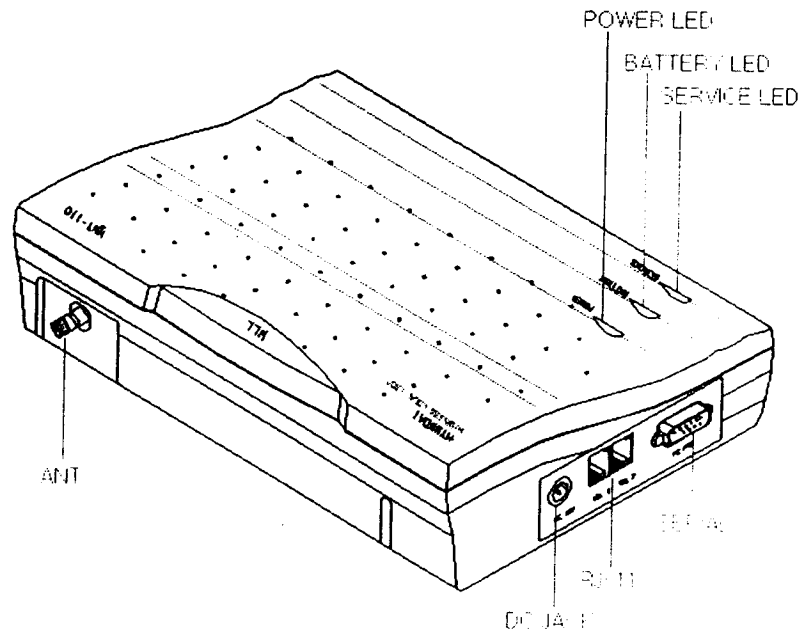

- Power LED  
It is always on when external power is supplied.  
- The terminal can be used without external battery if the backup battery is connected.



- **Battery LED**

It displays the status of the backup battery.

- It is on if the backup battery is connected.
- The terminal uses external power if it is available and the backup battery will be set to charging status.
- The LED blinks when the backup battery level falls to a certain level and if that happens, the user should charge it using external power or SMPS.
- The terminal can still be operable within ten minutes after the battery starts blinking.

- **Service LED**

It displays whether a call can be made or not.

- LED off: It means service is not available as the receiving field strength is weak.
- LED blinking: It means service is available even though the receiving field strength is weak.
- LED on: It means the receiving field strength is high and the service is available.

- **DC jack**

The part is a receiving point of the SMPS or power supply device for the WLL terminal.

- AC input power between 90 and 270V can be used for the SMPS.

- **Serial port**

The port is for maintenance and data communication of the WLL terminal.

- **RJ-11 jack**

The port is to connect a subscriber's telephone.

- As two jacks are provided, two telephones can be connected at the same time. One can't substitute the other.
- You can use any of the two jacks to connect a phone.
- Up to five telephones can be connected to the RJ-11 jack.

- **Power switch**

It is to connect power to the WLL terminal



Date	Doc. No.	Rev. Code	Page
Feb 28, 2000		1.1	6 (26)

### 1.3 Cautions

- 1) Please do not disassemble or modify the WLL terminal on your own.
- 2) Please do not hold the antenna during the call or let it contact any of your body parts.
- 3) Please do not use it in high temperature and humid place. It can be non-repairable if it gets wet by rain or by soft drinks.
- 4) Keep it safe from vibrations and shocks and place it in safe place when you don't use it.
- 5) Do not use it where explosives and inflammable liquid is.
- 6) Do not clean the WLL terminal with chemicals like solvent.
- 7) Remove the SMPS and backup battery from the WLL terminal if it is left unused for long period of time.

## II. Installation

### 2.1 General installation

- 1) Turn off the battery switch on the bottom of the terminal.
- 2) Open the cover by pushing the fixing terminal on the back of the terminal toward the direction of the arrow.

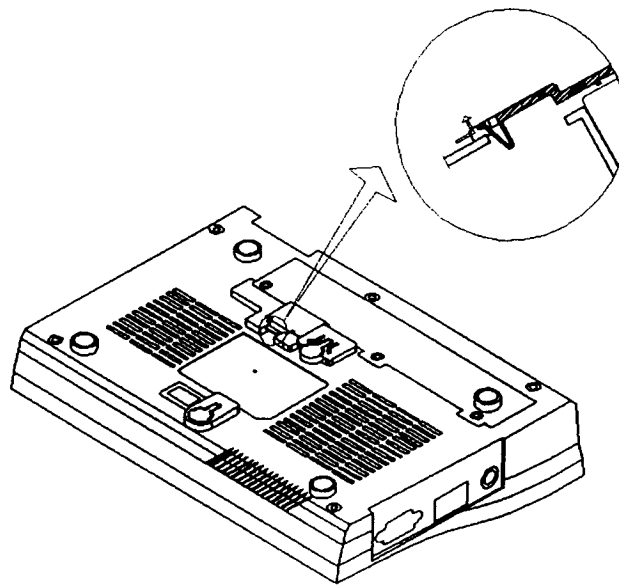

- 3) If the cover is open, you can see the connector connected to the backup battery. As shown in the following figure, hold the connector with its cramp-shaped part being placed in the above. Then, push it to the direction of the arrow and connects it to connector on the circuit board.

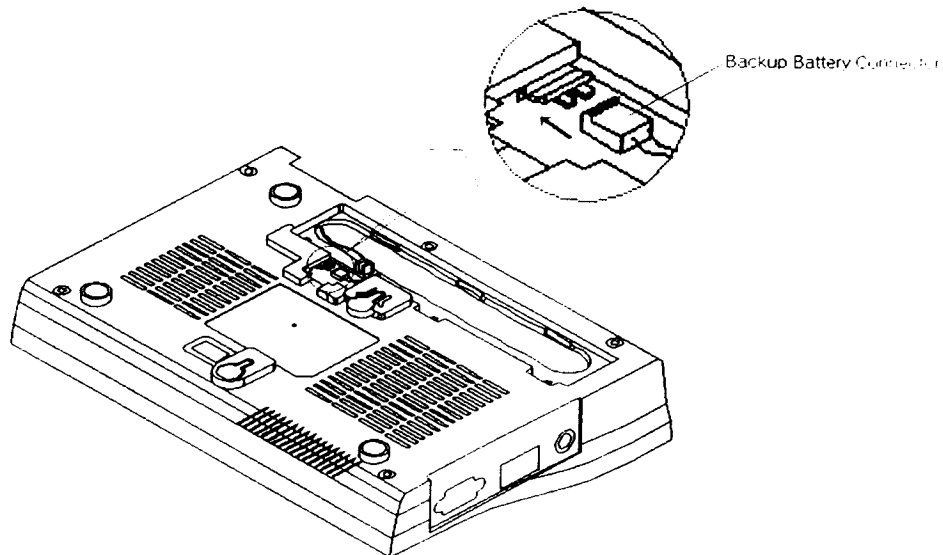

Note: If the connector is connected in opposite ways from the instruction, it can cause non-repairable damage to the terminal. Double check whether it is installed correctly before you move to





the next step.

- 4) Place the cover back after connecting the battery connector to the one in the circuit board. And fix it with screws.

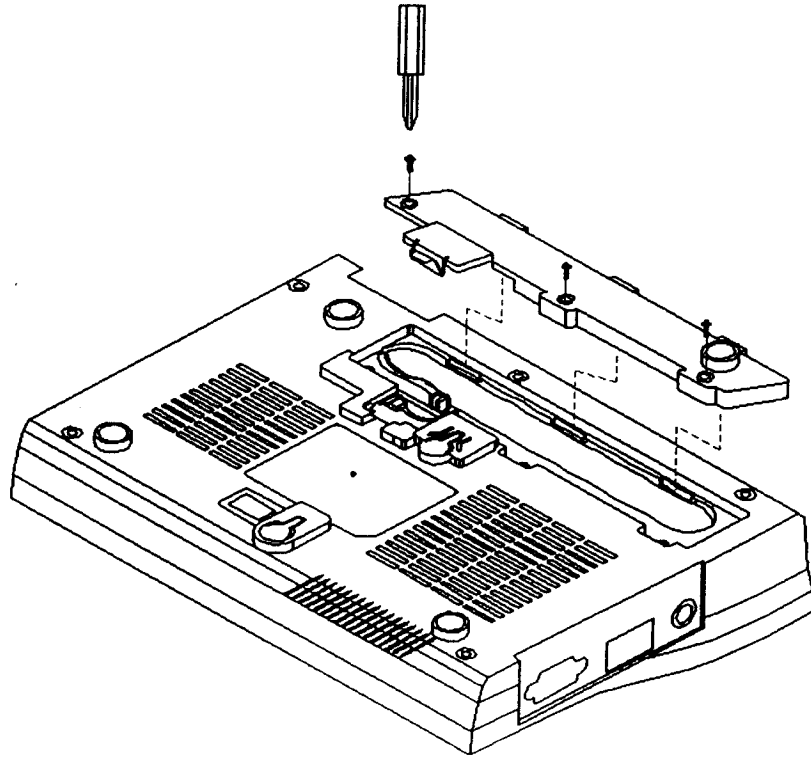

- 5) Thrust in the antenna as shown in the following figure and connect it by turning it in clock-wise.

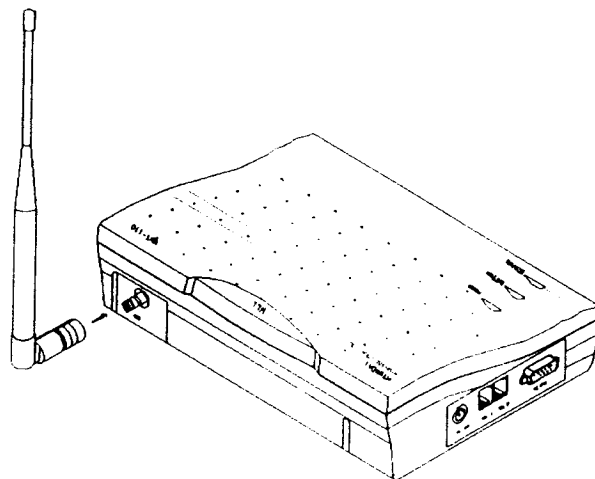

- 6) Connect the telephone (standard) to the RJ-11 jack as follows. You can use any of the two RJ-11



jacks.

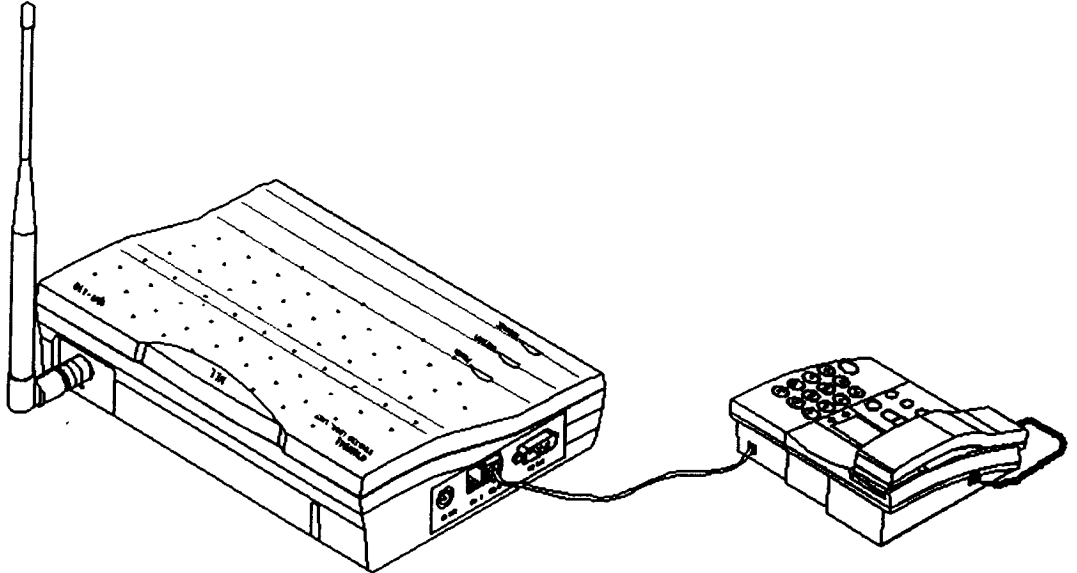

- 7) Connect the SMPS to the DC-jack in the left side of the terminal  
Push the power jack gently until it does not go in any more.

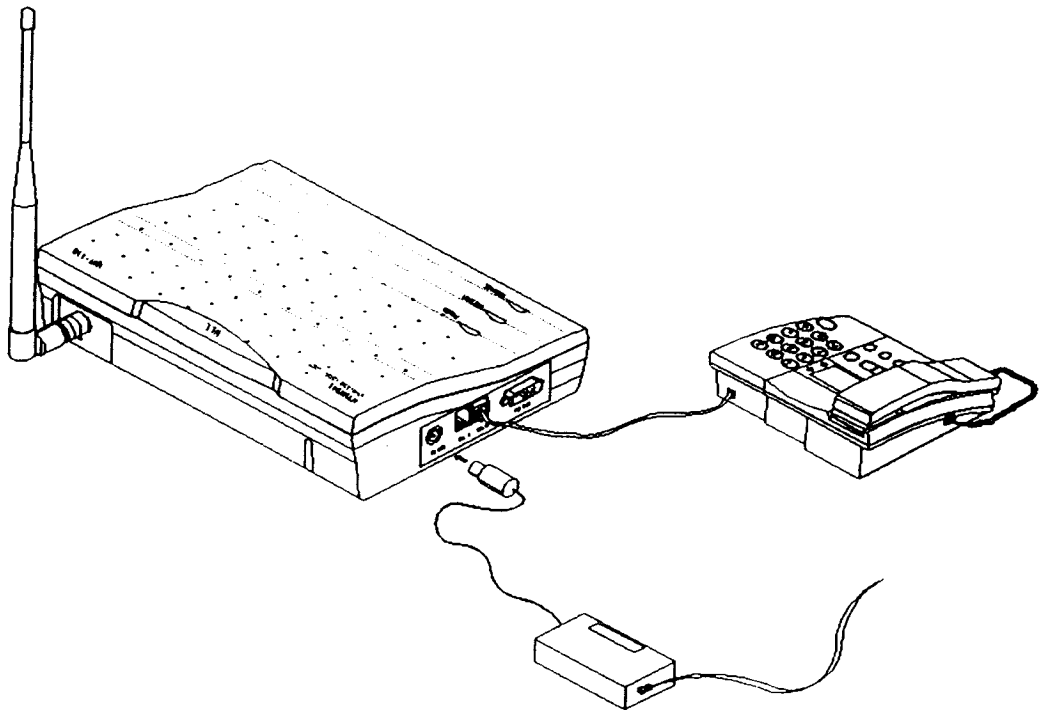

- 8) Connect the SMPS power plug to the power outlet.

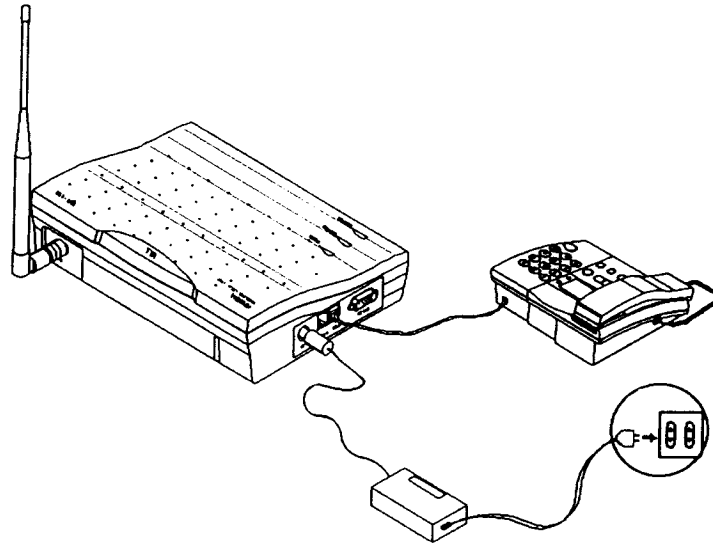

9) Turn on the battery switch on the bottom of the terminal.

After that, it operates as followings:

- The LED of the currently used one will be on after all of the three LEDs turn on.
- The service LED turns on if the service is available.



## 2.2 Wall bracket installation

- 1) If the wall is made of concrete, place the installation sheet on the wall and drill down the fundamental holes.

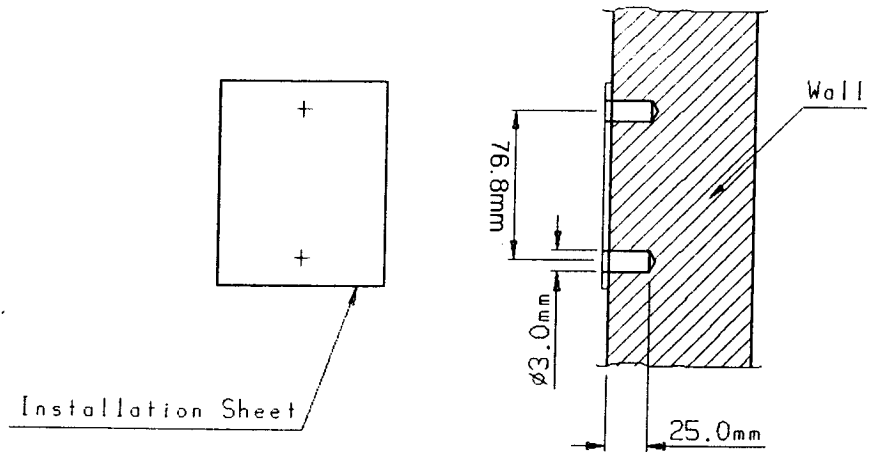

- 2) Place screws on the holes as followings:

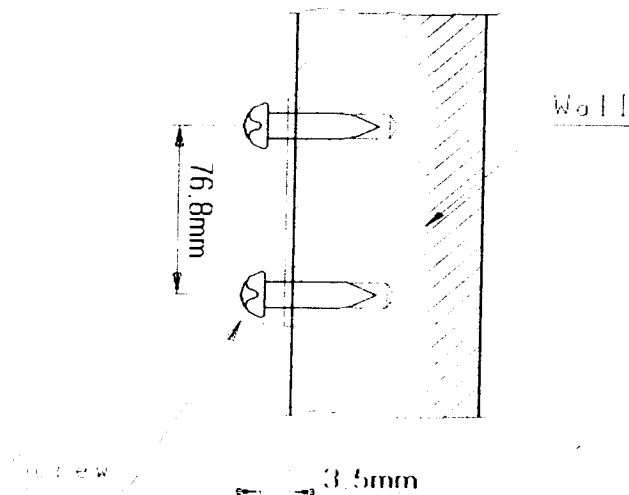

- \* If the wall is made of wood, you don't have to drill down holes. Place the installation sheet and fix screws on it

The distance between the wall to the screw head should be kept as shown in the figure 2).

3) Put A1 and A2 parts of the terminal on the screw head and press them down to hold.

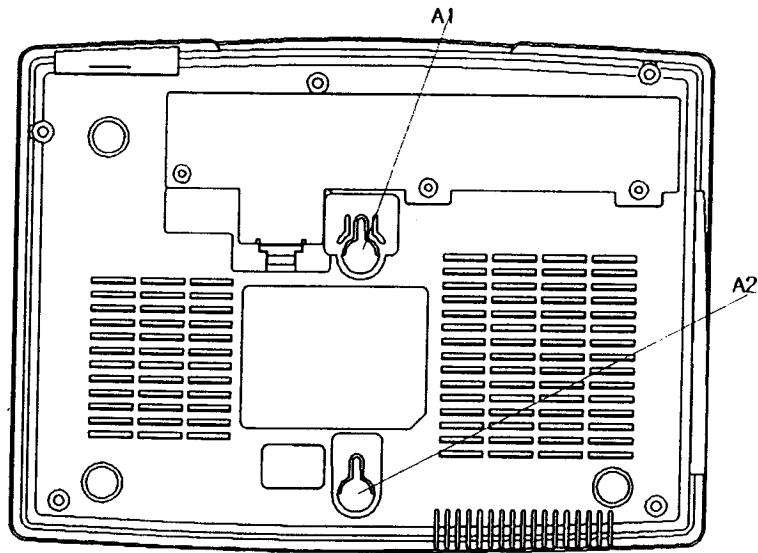

4) It will be seen as followings after the installation.

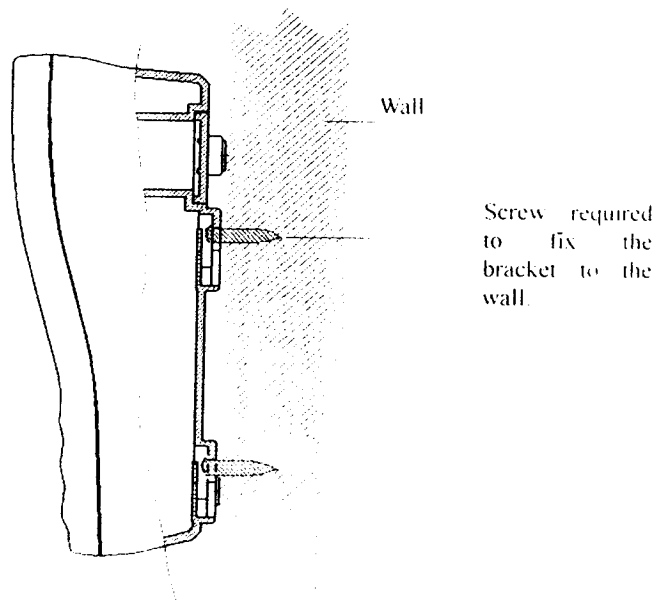

- ✧ For better call quality, you can install external panel antenna. (Please contact the vendor if you want to get the panel antenna).
- ✧ The backup battery is built in the WLL terminal so that it can operate without power for some time.



## 2.4 Installation for data service

### 1) PC connection to WLL terminal

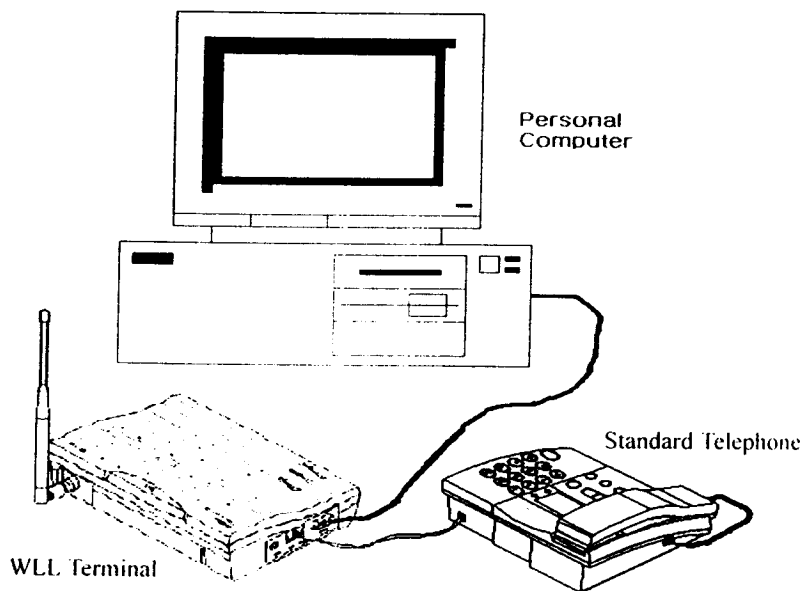

#### <PC Connection to WLL Terminal for Data Service>

As shown in the above figure, connect serial port of WLL terminal to COM1(COM2) of PC with RS232 cable.



### III. Basic Operation

#### 3.1 Power on

##### 3.1.1 Using external power

Connect power supply (SMPS) to DC-jack on the left of the terminal and then insert a power plug of SMPS in the outlet. At this time, push power jack with adequate force until it is no longer pushed in. When power is applied to the terminal, all of the three LEDs are turned on and then the external power LED on the top is turned on. If call is available, service LED on the bottom is turned on.

##### 3.1.2 Using built-in battery

When you apply power, using the battery built in the terminal, select the battery switch on the bottom of the terminal as ON. Then, charge the battery fully. If external power is applied to the battery, it will be automatically charged. If power is fed into the terminal, all of the three LEDs are turned on and then the LED in the middle of them is turned on. If call is available, service LED on the bottom is turned on.

#### 3.2 Power off

In case the external power is applied, just pull out the plug of SMPS and, in case power is applied by built-in battery, switch off the battery on the bottom of the terminal.

#### 3.3 To make a call

##### 3.3.1 General

- 1) You can hear a dial tone if you pick up a receiver in on-hook state. (If it is no service, you can hear warning tones every 0.5-second).
- 2) You cannot make any call if it is in no service state or when the service LED turns off.
- 3) Press the number of your counterpart and wait for four ~ eight seconds. The call will be connected automatically.
- 4) Talk to each other when the call is set up.
- 5) Put the receiver down to finish the call.

##### 3.3.2 Redial

The function is used to make a call again to the number that you have called the latest.

- 1) You can connect to the number that you have called the latest by picking up the receiver and pressing the hook switch. If it is your first call after the power starts being supplied, this function will not work.
- 2) Pick up the receiver and click the hook switch. Refer to the description in 3.5 for the click time.
- 3) Talk to each other when the call is set up.
- 4) Put down the receiver to finish the call.



### 3.3.3 End of digit

You can send the dial by clicking hook switch within the sending stand-by time (4~8 seconds) after dialing.

- 1) Pick up the receiver and dial the number.
- 2) The dial is sent just after clicking the hook switch. Refer to the description in 3.5 for the click time.
- 3) Talk to each other when the call is set up.
- 4) Put down the receiver to finish the call.

### 3.3.4 Speed dial

To use this function, speed dial function should be set up. See Section 4.1 for setup.

#### 1) In case of 1 digit

In case 01~09 is used as speed dial, pick up the phone and press the last number (0~9) and hook switch or hold the appropriate number.

If call is connected, have a conversation with each other. To terminate the call, hang up the phone.

#### 2) In case of 2 digits

In case 10~99 are used as speed dials, pick up the phone and press the number 10~99 and hook switch, or press the first digit shortly and hold the second digit.

If call is connected, have a conversation with each other. To terminate the call, hang up the phone.

## 3.4 To answer a call

### 3.4.1 If the standard telephone is in on-hook status,

- 1) Pick up the phone when it rings in standard telephone.
- 2) Talk to each other when the call is set up.
- 3) Put down the receiver to finish the call.

### 3.4.2 If the standard telephone is in off-hook status,

- 1) Answer the phone by pressing the hook switch when ring signals are heard in the receiver of standard telephone.
- 2) Talk to each other when the call is set up.
- 3) Put down the receiver to finish the call.





### 3.5 Analog G3 fax service

To transmit and receive documents by using analog G3 fax service of the terminal equipped with analog G3 fax board, follow the procedures.

#### 3.5.1 To transmit documents

Press “\*00” before entering the number of the called party. After that, follow the ordinary procedures.

#### 3.5.2 To receive documents

To receive documents in analog G3 fax, set the analog termination mode.

Pick up the transceiver of fax and press “\*\*\*\*15\*”. This will set the termination mode of the analog G3 fax (operated in this mode until the power is off).

You cannot receive the voice data if you do not release the termination mode. To release the mode, pick up the transceiver of the fax and press “\*\*\*\*10\*”.

### 3.6 Data service

This service allows the Internet access, PC communication and data transmit/receive via fax by connecting PC to WLL terminal.

A few service providers may not support the wireless data communication. Please check it before using the service.

It is necessary to purchase the cable for data communication from service provider.

For the computer preferences and other information, please refer to the user manual attached to the purchased cable for data communication.

#### 3.6.1 Set the data service terminating mode

##### 1) Based on the standard telephone

This function is to set up terminating mode according to the type of data service based on the standard telephone connected to WLL terminal.

1. Pick up the standard telephone's receiver, press “\*\*\*\*10\*”. This will make the terminating mode of data service released.
2. Pick up the standard telephone's receiver, press “\*\*\*\*11\*”. This will make the fax terminating mode set (operated just one time in this mode). After 10 minutes, this mode will be released automatically.
3. Pick up the standard telephone's receiver, press “\*\*\*\*12\*”. This will make the fax terminating mode set (operated in this mode until the power is off).
4. Pick up the standard telephone's receiver, press “\*\*\*\*13\*”. This will make the modem terminating mode set (operated just one time in this mode). After 10 minutes, this mode will be released automatically.



- ⑤ Pick up the standard telephone's receiver, press `****14*`. This will make the modem terminating mode set (operated in this mode until the power is off).
- ⑥ The default is `****10*`.

## 2) Based on AT command

This function is to set up the terminating mode according to the type of data service by using communication emulator program of PC connected to WLL terminal.

- ① Enter `AT+HDVAD=0` in emulator program and press Enter key.  
'OK' will be displayed when the setting is completed. This will make the terminating mode of data service released.
- ② Enter `AT+HDVAD=1` in emulator program and press Enter key. 'OK' will be displayed when the setting is completed. This will make the fax terminating mode set (operated just one time in this mode). After 10 minutes, this mode will be released automatically.
- ③ Enter `AT+HDVAD=2` in emulator program and press Enter key.  
'OK' will be displayed when the setting is completed. This will make the fax terminating mode set (operated in this mode until the power is off).
- ④ Enter `AT+HDVAD=3` in emulator program and press Enter key.  
'OK' will be displayed when the setting is completed. This will make the modem terminating mode set (operated just one time in this mode). After 10 minutes, this mode will be released automatically.
- ⑤ Enter `AT+HDVAD=4` in emulator program and press Enter key.  
'OK' will be displayed when the setting is completed. This will make the modem terminating mode set (operated in this mode until the power is off).
- ⑥ The default is `AT+HDVAD=0`.



## IV. Additional Functions

### 4.1 Speed dial

Speed dial function enables you to register frequently used telephone numbers as addresses in advance and make a call fast by invoking the numbers. Up to 99 telephone numbers can be entered and initial state is set as OFF.

#### 4.1.1 Registering telephone number

Press ##3233→1→1, enter the address to save as 2 digits and enter the desired telephone numbers consecutively and then press \* button (save).

##3233→1→1→address (2 digits)→telephone number→\*

entering telephone number

#### 4.1.2 Deleting telephone number

Press ##3233→1→2, enter the address to delete and press \* button. To delete all of the registered numbers, press ##3233→1→3 and press \* button.

##3233→1→2→address (2 digits)→\*

: deleting individual address (1)

##3233→1→3→\*

: deleting all the addresses

#### 4.1.3 Setting (On) and clearing (off) speed dial function

Press ##3233→1→4 and press \* button (On). Even if a telephone number is saved in memory address, speed dial mode can operate only if speed dial function is set as ON.

To clear the function, press ##3233→1→5 and press \* button (On)

##3233→1→4→\*

: setting speed dial function (ON)

##3233→1→5→\*

: clearing speed dial function (OFF)

#### 4.1.4 Speed dialing (making a call)

If a telephone number is registered in the appropriate address and speed dial function is set (ON), it is possible to make a call only by entering the appropriate address. In case the registered address is 1 digit (01-09), you can make a call just by holding the last digit, or pressing the digit shortly and pressing the hook switch.

In case the registered address is made up of two digits (10-99), you can make a call just by pressing the first digit shortly and holding the second digit, or pressing both the two digits shortly and entering the hook switch.



If you attempt speed dialing when speed dial function is OFF, you hear rejection tone and call is not connected.

## 4.2 Emergency call hold

Emergency call hold function enables you to register up to three telephone numbers (01~03 addresses) in preparation for urgent situations and to make calls fast with the abbreviated dialing. Calls remain connected unless the called party hangs up the phone, and the initial state is set as OFF.

### 4.2.1 Setting (ON) and clearing (OFF) emergency call hold

Press ##3233→1→6 and press \* button (On). Emergency call hold function can operate only if the telephone number is registered and emergency call function is set as ON. The method to enter the telephone number in the 01~03 addresses is the same as 4.1.1.

To clear the function (OFF), press ##3233→1→7 and press \* button.

##3233→1→6→\*

: setting emergency call function (ON)

##3233→1→7→\*

: clearing emergency call function (OFF)

### 4.2.2 Emergency calling (making a call)

If a telephone number is registered in 01~03 address and emergency call function is set (ON), you can make a call just by holding the last digit of the address, or pressing the two digits shortly and entering the hook switch. Calls remain connected unless the called party hangs up the phone.

If you attempt abbreviated dialing when emergency call hold and speed dial are set at the same time (ON), 01~03 addresses operate in the emergency call hold mode.

If you attempt abbreviated dialing when emergency call hold function is cleared (OFF) and speed dial function is set (ON), 01~03 address operates in the speed dial mode.

#### Ref: Warning Tone-Howler Tone

If you pick up the phone (off-hook) and do not press any button for 10 seconds, dial tone is changed into the warning tone. At this time, you can receive calls, but cannot enter numbers to make calls. To make calls, press the hook switch and enter telephone numbers again.

If you do not enter any numbers for 15 seconds after the warning tone is heard, the tone is changed into the howler tone. (In case a buzzer is installed, it is activated). At this time, you cannot make or receive calls until you go on-hook.

#### Ref: Confirmation Tone Reject Tone

When you set up all the additional functions by pressing related keys normally and press \* button (save) finally, the mode of the telephone returns to the original state and you can hear the confirmation tone that indicates all functions are set successfully. If you enter wrong keys, you can hear the reject tone that indicates certain keys are wrongly pressed. Therefore, you can restart from the procedure.



## 4.3 Hot line

With the hot line function, you can make a call automatically without entering any telephone numbers. That is, if you register one frequently used number (99 address) in advance and remain off-hook for 4~8 seconds (dial time), a call is connected to the registered number automatically. The initial state is set as OFF.

### 4.3.1 Setting (On) and clearing (off) hot line

Press ##3233→1→8 and press \* button (On). Hot line mode can operate only if telephone number is saved in the 99 address and hot line function is set as ON.

To clear the function, press ##3233→1→9 and press \* button.

##3233→1→8→\*

: setting hot line function (ON)

##3233→1→9→\*

: clearing hot line function (OFF)

### 4.3.2 Hot line calling (making a call)

In case a telephone number is registered in the 99 address and hot line function is set (ON), if you pick up the phone and wait time (4~8 seconds) passes, call is automatically made to the telephone number saved in the 99 address.

## 4.4 Alarm reminder

Alarm reminder function activates the alarm ring when the registered time arrives, and stops the ring when you pick up the phone. The initial state is set as OFF.

### 4.4.1 Setting (On) and clearing (off) alarm reminder

Press ##3233 →2 →1 and enter the desired time as 4 digits (24 hour system) and then press \* button (On). If you enter a desired time, alarm function is automatically set one time and when the time arrives, alarm ring is activated and the alarm function is cleared (OFF). If you want to activate the alarm rings at a designated time everyday, enter ##3233 →2 →3 →\*, and to clear it, press ##3233 →2 →4 →\*.

##3233 →2 →1 →time (4 digits, 24 hour system) →\*

: setting alarm reminder (one time)

##3233 →2 →3 →\*

: setting alarm reminder (always)

##3233 →2 →4 →\*

: clearing alarm reminder



## 4.5 Lock

It is a function of setting password in terminal so that it is impossible to make a call without a password. If a call is attempted with the lock function set, a warning tone will be heard and the call attempt will fail (receiving a call is still possible.) However, if the emergency call function is set, only emergency calls can be made (the calls with the area code of 01~03) and the initial state is set to OFF.

### 4.5.1 Setting (On) and clearing (off) lock

Press ##3233→3 and enter a 4 digit password. When you enter a wrong password, you hear a rejection tone. Then, you can re-enter the password. If the entered password is correct, press 1 followed by \* button (Lock On). To clear lock function, press ##3233→3→password→2→\*.

##3233→3→password→1→\*

: setting lock function

##3233→3→password→2→\*

: clearing lock function

### 4.5.2 Changing a password

To change a password, press ##3233→3 and enter the password. After pressing 3, enter a new password and press \* button. If you re-enter the new password and press \* button, the old password will be replaced with the new one.

##3233 → 3 → password → 3 → new password → \* → new password → \*

: changing a password

## 4.6 Earpiece Volume control

It is the function used to control the ear piece volume. The initial value is set to "level 3".

### 4.6.1 How to use the earpiece volume control function

1) Press ##3233 → 4 → 1. Out of the buttons 1(level 1), 2(level 2), 3(level 3), 4(level 4), 5(level 5), press the one corresponding to the desired volume and press \* button.

##3233 → 4 → 1 → 1 ~ 5 → \*

: setting earpiece volume control (method 1)

2) Pick up the handset and press ##37. Then, out of numbers 01 ~ 05, press the one corresponding to the desired volume. If entering the number is finished, a dial tone will be heard. "01" generates the lowest volume. The bigger the number is, the higher the volume.

##37 → 01 ~ 05

: setting earpiece volume control (method 2)



## 4.7 Reset to default values

It is the function of returning to the default values. The current values will be returned to the original values as speed dial(off), emergency call hold(off), hot line call(off), alarm mode(off), lock mode (off), earpiece volume(3). It is not desirable that users operate reset menu frequently.

Reset menus	Default values
Speed dial	Off
Emergency call hold	Off
Hot line call	Off
Alarm	Off
Lock	Off
Earpiece volume	Level 3

### 4.7.1 How to use the reset function

1) Press ##3233→4→0. Then enter the password and press \* button.

##3233 → 4 → 0 → password → \*

: reset to the default values



## Appendix

### 1. Summary of Additional Functions (Summary Table)

Saving/deleting telephone number	Saving memory	##3233→1→1→memory address→telephone numbers→*
	Deleting one memory	##3233→1→2→memory address→*
	Deleting all addresses	##3233→1→3→*
Speed dial	Setting function	##3233→1→4→*
Emergency call hold	Clearing function	##3233→1→5→*
	Setting function	##3233→1→6→*
	Clearing function	##3233→1→7→*
Hot line	Setting function	##3233→1→8→*
	Clearing function	##3233→1→9→*
Alarm reminder	Entering time (setting one time)	##3233→2→1→time (4 digits, 24 hour system)→*
	Always mode	##3233→2→3→*
	Alarm off	##3233→2→4→*
Lock	Setting function	##3233→3→password→1→*
	Clearing function	##3233→3→password→2→*
	Changing password	##3233→3→password→3→newpassword→*→new password→*
Earpiece volume control (5 stages)	##3233→4→1→1/2/3/4/5→*	
Reset to default values	####→01/02/03/04/05	(1: minimum ← 3: medium → 5: maximum)
Receiving analog G3 Fax	Setting function (receiving fax)	****15*
	Clearing function (receiving voice mode)	****10*
Return to voice mode from fax (receive voice)	Using general telephone	****10*
	Using communication emulator	AT+HDVAD_0' → Enter key
Setting PC fax receiving mode (one time)	Using general telephone	****11*
	Using communication emulator	AT+HDVAD_1' → Enter key
Setting PC fax receiving mode (until power off)	Using general telephone	****12*
	Using communication emulator	AT+HDVAD_2' → Enter key
Setting modem termination mode (one time)	Using general telephone	****13*
	Using communication emulator	AT+HDVAD_3' → Enter Key
Setting modem termination mode (until power off)	Using general telephone	****14*
	Using communication emulator	AT+HDVAD_4' → Enter Key



## 2. HWT-120 TECHNICAL SPECIFICATION

Air interface	<ul style="list-style-type: none"> <li>- Common air interface standard: IS-95A</li> <li>- Frequency : TX: 824 - 849MHz RX: 869 - 894MHz</li> <li>- TX output power : 200mW</li> <li>- RX sensitivity : - 104dBm</li> <li>- Vocoder : 8K/13K QCELP 8K EVRC</li> <li>- Channel bandwidth : CDMA 1.25Mhz</li> <li>- Spurious : TX: -61dBm below : RX: -81dBm below</li> <li>- MOD/DEMOD : O QPSK/QPSK</li> <li>- Frequency accuracy : <math>F_0 \pm 300\text{Hz}</math></li> </ul>
Battery back-up	<ul style="list-style-type: none"> <li>- Type : Ni-Cd</li> <li>- Capacity : 8.4V @ 1.7A</li> <li>- Talk time: 2 hours</li> <li>- Standby time: 20 hours</li> </ul>
Connectors for various service support	<ul style="list-style-type: none"> <li>- RJ-11: standard wire-line telephone : Analog G3 fax (Optional)</li> <li>- Serial port : Maintenance purpose : Data service purpose (Internet, PC fax)</li> </ul>
Physical	<ul style="list-style-type: none"> <li>- Dimension (D×W×H) : 266×166×65mm</li> <li>- Weight (including backup battery): 1100g</li> </ul>
Environmental	<ul style="list-style-type: none"> <li>- Operating temperature: -10 °C ~ +50 °C</li> </ul>
Power supply	<ul style="list-style-type: none"> <li>- Input power : 110 - 240V( ±20V), 50/60Hz</li> <li>- Output power: DC 12V @ 2A</li> </ul>
Accessories	<ul style="list-style-type: none"> <li>- Internal antenna: Di-Pole antenna</li> <li>- Power supply</li> </ul>