

HYUNDAI

Wireless Local Loop
HWT-210 User Manual

Hyundai Electronics Industries



FCC RF EXPOSURE INFORMATION

WARNING! Read this information before using your WLL

In August 1996 the Federal Communications Commission (FCC) of the United States with its action in Report and Order FCC 96-326 adopted an updated safety standard for human exposure to radio frequency (RF) electromagnetic energy emitted by FCC regulated transmitters. Those guidelines are consistent with the safety standard previously set by both U.S. and international standards bodies. The design of this phone complies with the FCC guidelines and these international standards.

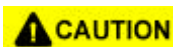

This device was tested for RF exposure compliance with the back of the phone kept 3cm (1.2 inches) from the body. To comply with FCC RF exposure requirements, a minimum separation distance of 3cm (1.2 inches) must be maintained between the user/bystander and the back of the phone, including the antenna.

For more information about RF exposure, please visit the FCC website at www.fcc.gov

--- Contents ---

1. Before Using	2
1.1 .Checking the Package	2
1.2. Name and Function of Each Part	3
1.3. Cautions	3
2. Installation	5
2.1. General Installation	5
2.2. Installation of Wall Bracket	8
2.4. Setup for Data Service	11
2.4.1 Connection between PC and the WLL terminal..	11
3. How to Use	11
3.1. To Make a Call	11
3.1.1. General	11,
3.1.2. Redial Function	12
3.1.3. End of Digit Function.....	12
3.2. To Answer a Call	12
3.2.1.. When the subscriber is in on-hook status	12
3.2.2. When the subscriber is in off-hook status	12
3.3. To Adjust Volume	12
3.4. To Adjust Signal Sending Stand-by Time after Dialing	
3.5. To Adjust Hook Flash Time (Click Time)	13
3.6. To Use Data Service	13
3.6.1 Data Service Receiving mode Setup Function	13
3.7 To use G3 Fax Service(Optional).....	13

<Appendix>

1. HWT-2 10 Features
2. Technical Specification

1. Before Using

This product is WLL terminal (Wireless Local Loop Terminal) designed based on CDMA, one of the most advanced communication technologies to fully satisfy your demands for improved communication services. Please, make sure that you read through the manual before using.

* Notes: please connect the terminal to the backup battery, as they are not connected at the time of the delivery. You can refer to "2.1 General Installation" of the manual.

1.1. Checking the Package

Thank you for purchasing the product. Please check whether your goods include each of the following contents.

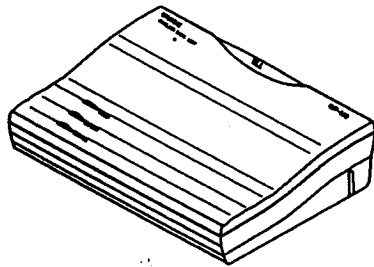

- WLL Terminal -



- Antenna -

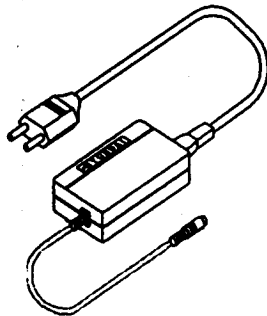

- Power Supply (SMPS) -

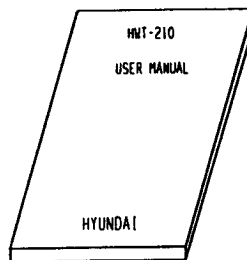

- User Manual -

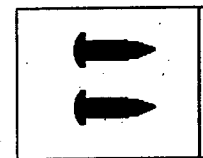

- Screws -

1.2. Name and Function of Each Part

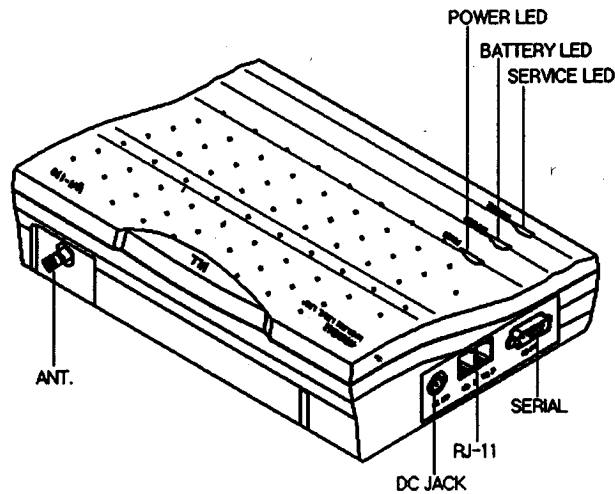

● Power LED

It is always ON when external power is supplied.

- You can use the WLL terminal without external power battery if the backup battery is connected.

● Battery LED

It indicates the state of the backup battery.

- If the power is supplied by backup battery, not by external power.
- The terminal uses external power if it is available and the backup battery will be set to charge status.
- The LED blinks if the backup battery level falls down to a certain level or below and if that happens, the user should charge it using external power or SMPS.
- The terminal can still be operable for ten minutes after the battery starts blinking.

● Service LED

It indicates whether a call can be made or not.

- LED OFF: It means service is not available as the strength of receiving power is weak.
- LED Blink: It means service is available even though the strength of receiving power is weak.
- LED ON: It means the strength of receiving power is high and the service is available.

● DC Jack

The part is a receiving point of the SMPS or power supply device for the WLL terminal.

- AC input power from 90 to 270V can be used for the SMPS.

- **Serial Port**

This port is for maintenance and data communication of the WLL terminal.

- **RJ-11 Jack**

This port is to connect a subscriber's telephone.

- As two jacks are provided, two telephones can be connected at the same time. One can't substitute the other.
- You can use any of the two jacks to connect a phone.
- Up to five telephones can be connected to the RJ-11 jack.

- **Battery On/Off Switch**

It is to connect backup battery to the WLL terminal.

1.3. Cautions

- Please do not disassemble or modify the WLL terminal on your own.
- Please do not hold the antenna during the call or let it contact any of your body parts.
- Please do not use it in high temperature and humid place. It can be non-repairable if it gets wet by rain or by soft drinks.
- Keep it safe from vibrations and shocks and place it in safe place when you don't use it.
- Do not use it where explosives and inflammable liquid is.
- Do not clean the WLL terminal with chemicals like solvent.
- Remove the SMPS and backup battery from the WLL terminal if it is left unused for long period of time.
- The backup battery should be used after being charged for long enough like more than 30 hours as it can be discharged.

2. Installation

2.1 General Installation

- 1) Turn off the battery switch on the bottom of the terminal.
- 2) Open the cover by pushing the screw on the back of the terminal to the direction of the arrow.

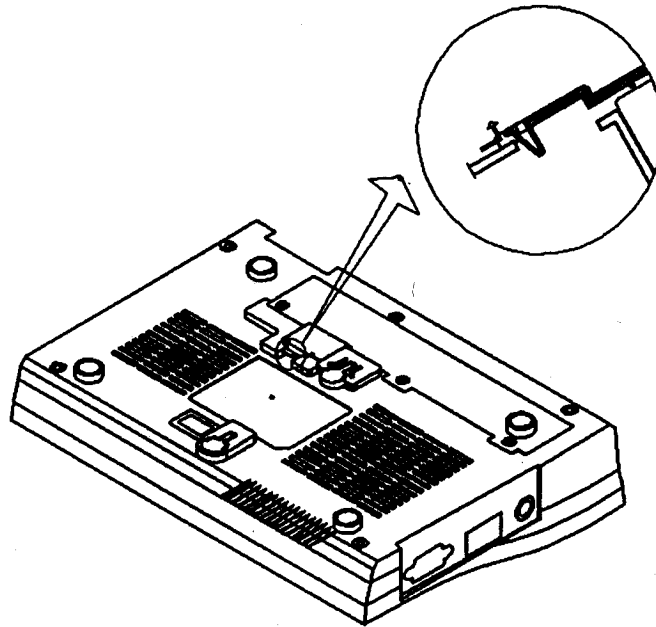

- 3) When you open the cover you can see the connector connected to the backup battery. As shown in the following figure, hold the connector with its cramp-shaped part being placed in the above. Then, push it to the direction of the arrow and connects it to the circuit board.

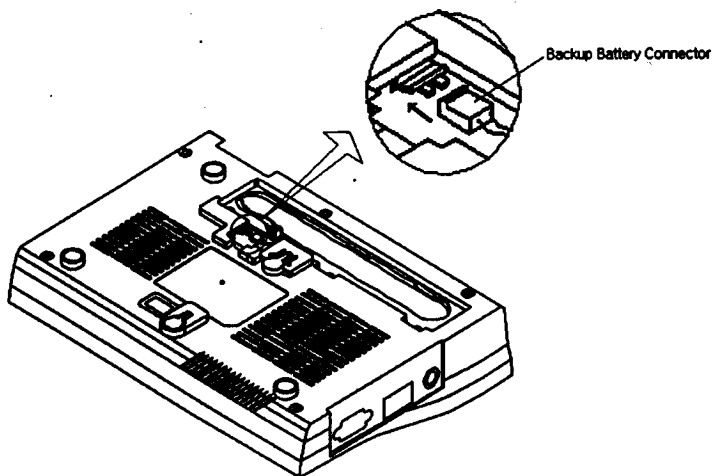

☞Note: If the connector is connected in opposite ways from the instruction, it can cause non-repairable damage to the terminal. Double check whether it is installed correctly before you move to the next step.

- 4) Place the cover back after linking the battery connector to the one in the circuit board. And settle it with a screw.

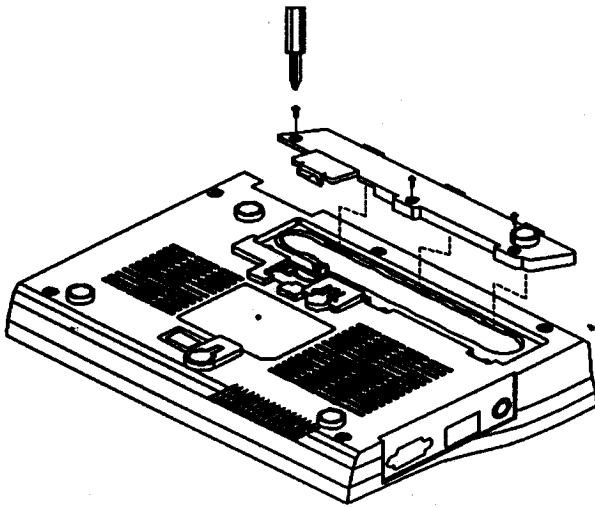

- 5) Thrust in the antenna as shown in the following figure and connect it by turning it in clock-wise.

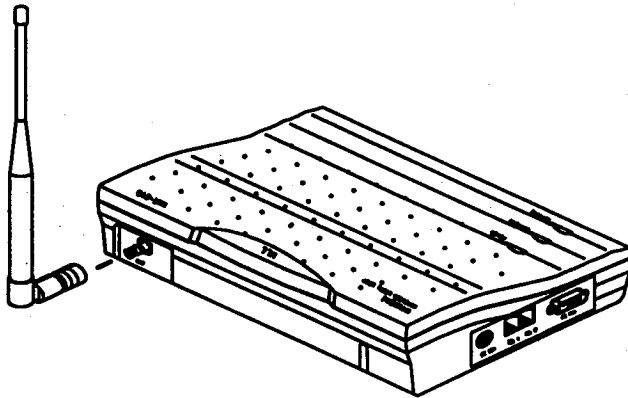

- 6) The subscriber's telephone is connected to the RJ-11 jack as following. You can use any of the two RJ-11 jacks.

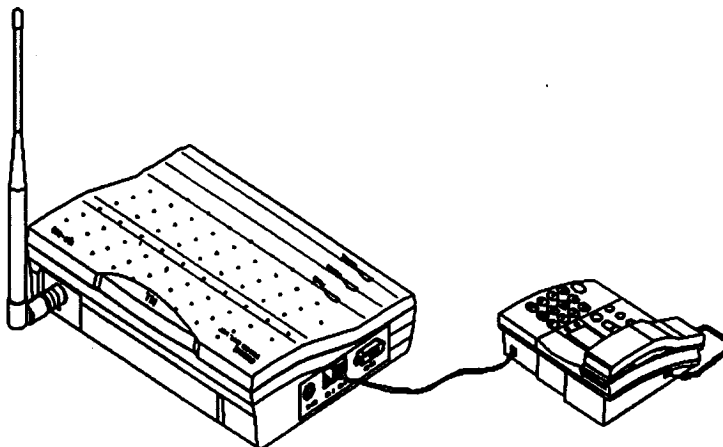

- 7) Connect the SMPS to the DC-jack in the left side of the terminal.
Push the power jack gently until it doesn't go any more.

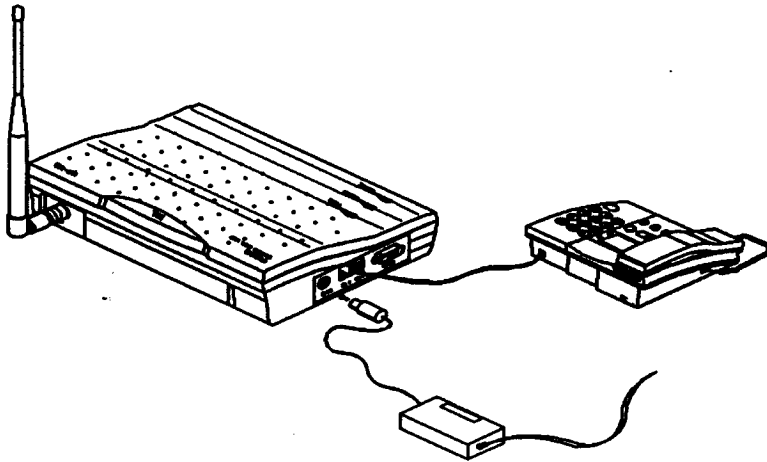

- 8) Connect the SMPS power plug to the power outlet.

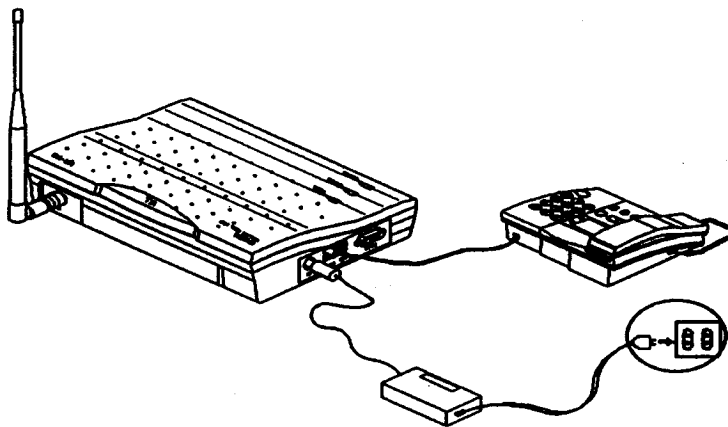

- 9) Turn on the battery switch on the bottom of the terminal.
After that, it operates as followings:
- The LED of the currently used one will be ON after lightening all of the three LEDs
 - The service LED turns ON if the service is available.

2.2 Installation of Wall Bracket

- 1) If the wall is made of concrete, attach the installation sheet on the wall and drill the fundamental holes.

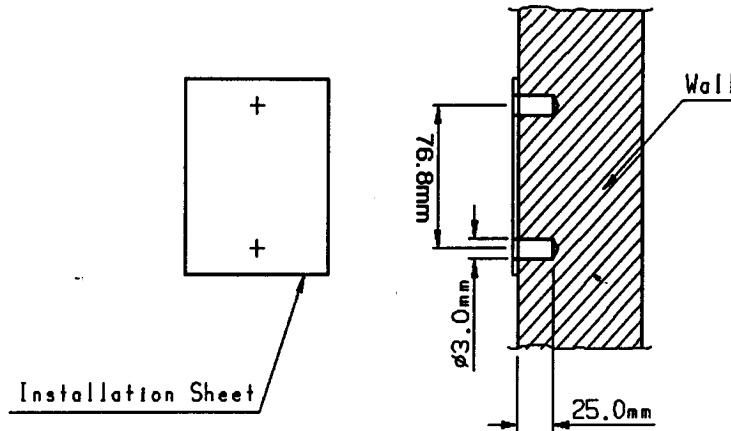

- 2) Place screws on the holes as followings:

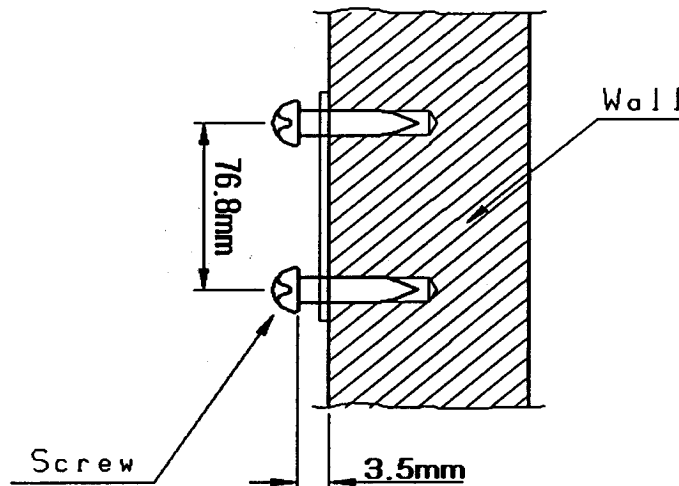

※ If the wall is made of wood, you don't have to drill holes. Place the installation sheet and fix screws on it.

The distance between the wall to the screw head should be kept as shown in the figure.

3) Put A1 and A2 parts of the terminal on the screw head and press them down to hold.

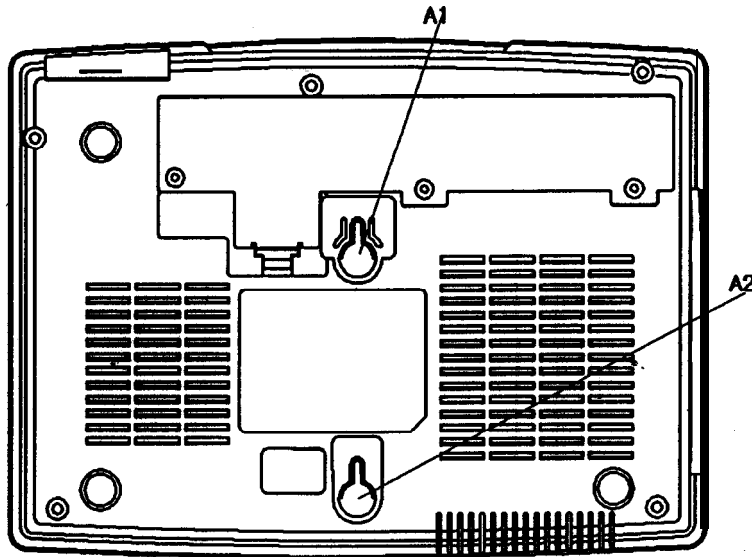

4) It will be seen as followings after the installation.

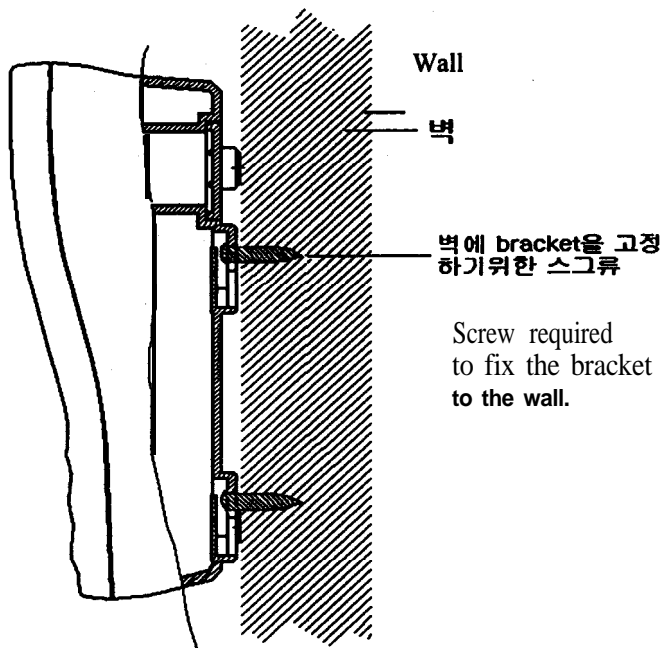

※

※ The backup battery is built-in within the WLL terminal so that it can operate without external power for some time. If the SMPS is removed, the backup battery starts to operate. It can be used about 15 hours in stand-by mode and two hours during the call.

2.4 Setup for Data Service

2.4.1 Connection between PC and the WLL terminal

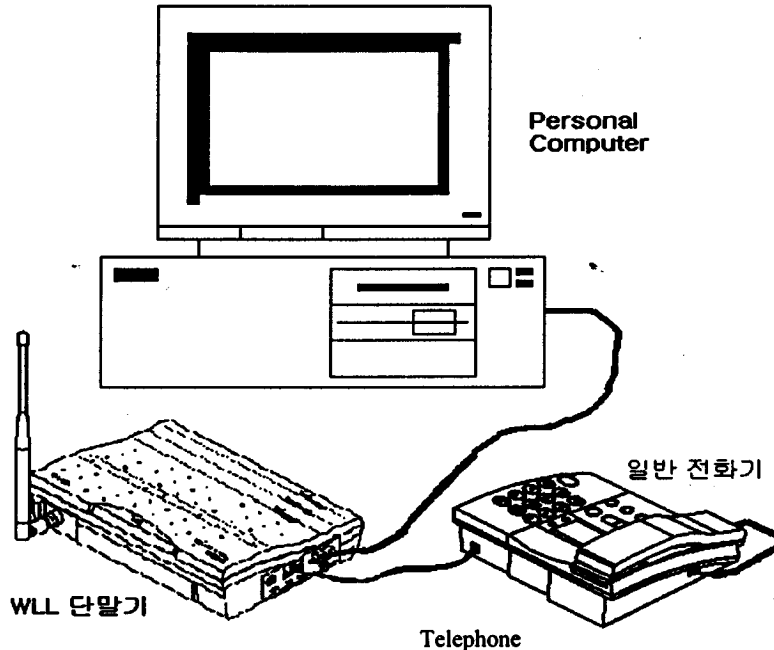

<Connection between the PC and WLL terminal for data communication>

Use the RS232 cable for connecting the serial port of the WLL terminal with COM1 (COM2) of PC as shown above figure.

3. How to Use

3.1. To Make a Call

3.1.1. General

- You can hear a dial tone when you pick up a receiver in on-hook status. (in no service, you can hear warning tones in every 0.5 second).
- You can't make any call if it is in no service state or when the service LED turns OFF.
- Press the number of your counterpart and wait for four - eight seconds. The call will be connected automatically.
- Talk to each other when the call is set up.
- Put the receiver down to finish the call.

3.1.2. Redial Function

This function is used to make a call again to the number that you have called the latest.

- You can connect to the number that you have called the latest by picking up the receiver and clicking the hook switch. If it is your first call after the power starts to be supplied, this function will not work.
- Pick up the receiver and click the hook switch. Refer to the description in 3.5 for the click time.
- Talk to each other when the call is set up.
- Put down the receiver to finish the call.

3.1.3. End of Digit Function

It is to reduce the time for dialing.

- Pick up the handset and press the number.
- The call is set up immediately if you click the hook switch. Refer to the description in 3.5 for the click time.
- Talk to each other when the call is set up.
- Put down the receiver to finish the call.

3.2. To Answer a Call

3.2.1. If the subscriber is in on-hook state

- The subscriber picks up the receiver when subscriber rings.
- Talk to each other when the call is set up.
- Put down the receiver to finish the call.

3.2.2. If the subscriber is in off-hook state

- The subscriber answers the phone by clicking the hook switch when ring signals are heard in the receiver.
- Talk to each other when the call is set up.
- Put down the receiver to finish the call.

3.3. To Adjust Volume

This function is to adjust the volume (sound level) of the receiver.

- Pick up the receiver of subscriber, press '####' and then press the figure of your choice between 01 and 05. You can hear dial tone after the input.
- 01 is the lowest level of sound. The higher the number is, the bigger the sound becomes.
- Default is '03'.

3.4 To Adjust Signal Sending Stand-by Time after Dialing

This function is to adjust the time that takes to set up a call automatically after pressing the number.

- Pick up the subscriber's receiver, press '****' and then press the figure of your choice between 04 and 08. You can hear dial tone after the input.
- '04' means the call will set up after four seconds and '08' means the call will set up after eight seconds.
- Default is '06'.

3.5 To Adjust Hook Flash Time (Click Time)

This function is to set up the time required to recognize clicking of hook switch for redial and End of Digit functions. You can hear dial tone after the input.

- Pick up the subscriber's receiver and press '####11'. This will set the time of 100~200ms.
- Pick up the subscriber's receiver and press '####12'. This will set the time of 100~500ms.
- Pick up the subscriber's receiver and press '####13'. This will set the time of 100~700ms.
- Pick up the subscriber's receiver and press '####14'. This will set the time of 100~1800ms.
- Default is '####13'.

3.6. To Use Data Service

- This service enables you to access the Internet and PC communication and to receive/transmit the fax message by connecting the PC to WLL terminal.
The wireless data communication service may not be available according to service provider. Please, check if the service provider is providing this service.
- Purchase the data communication cable from the service provider for this service.
- For more detailed information on computer environment setup and others, refer to user's manual which is provided together with the data communication cable.

3.6.1 Data Service Receiving Mode Setup Function

Method 1) Setup using subscriber's phone

This function sets up the receiving mode according to the data service type by using subscriber's phone which is connected to the WLL terminal.

- Pick up the subscriber's receiver and press '****10*'. This will release the data service receiving mode.
- Pick up the subscriber's receiver and press '****11*'. This will set the fax receiving mode (It will operate in fax receiving mode for one time). If ten minutes elapsed after the setup, the fax receiving mode is automatically released.
- Pick up the subscriber's receiver and press '****12*'. This will set the fax receiving mode (It will operate in fax receiving mode until power off).
- Pick up the subscriber's receiver and press '****13*'. This will set the modem receiving mode (It will operate in modem receiving mode for one time). If ten minutes elapsed after the setup, the modem receiving mode is automatically released.

- Pick up the subscriber's receiver and press '****14*'. This will set the modem receiving mode (It will operate in modem receiving mode until power off).
- Default is '****10*'.

Method 2) Setup using AT command

This function sets up the receiving mode according to the data service type by using the communication emulator program of PC which is connected to the WLL terminal.

- Enter 'AT+HDVAD=0' in the communication emulator program and then press Enter key. After the setup is completed, OK is displayed. This will release the data service receiving mode.
- Enter 'AT+HDVAD=1' in the communication emulator program and then press Enter key. After the setup is completed, OK is displayed. This will set the fax receiving mode. (It will operate in fax receiving mode only once.) If ten minutes elapsed after the setup, the fax receiving mode is automatically released.
- Enter 'AT+HDVAD=2' in the communication emulator program and then press Enter key. After the setup is completed, OK is displayed. This will set the fax receiving mode. (It will operate in fax receiving mode until power off.)
- Enter 'AT+HDVAD=3' in the communication emulator program and then press Enter key. After the setup is completed, OK is displayed. This will set the modem receiving mode. (It will operate in modem receiving mode only once.) If ten minutes elapsed after the setup, the modem receiving mode is automatically released.
- Enter 'AT+HDVAD=4' in the communication emulator program and then press Enter key. After the setup is completed, OK is displayed. This will set the modem receiving mode. (It will operate in modem receiving mode to the power off.)
- Default is 'AT+HDVAD=0'.

3.7 To use G3 Fax Service(Optional)

Reference: You have to buy WLL Terminal including G3 Fax Board additionally to use Analog G3 Fax service.

To transmit documents as following instructions.

3.7.1. To transmit documents

Enter recipient's phone number after "**00".

The remaining instructions are identical with how to use normal fax

2. 7.2. To receive documents

To receive documents, you have to set standby mode of Analog G3 Fax first of all.

To set standby mode of Analog G3 Fax, hold the handset and press "****15*" (It might remain Analog G3 Fax mode before Power Off)

Voice messages cannot be received unless canceling the Analog G3 Fax mode.

Hold the handset and press "****10*" to cancel the Analog G3 Fax mode.

<Appendix>

1. Features

General	<ul style="list-style-type: none"> - Connection with normal telephone - Line interface capability : 2 wire - 3 LED (Power, Battery, Service) - Wall Mountable
Local Tone	<ul style="list-style-type: none"> - Dial tone - Busy tone - Warning Tone
Hook Flash Operation	<ul style="list-style-type: none"> - Last Number Redial - End of Digit
User Control	<ul style="list-style-type: none"> - Received Volume Control : Sstep - Dial Time Control : 4s ~ 8s - Hook Flash Time(Click Time) Control

2. Tech&al Specifrc'a'tion

Air Interface	<ul style="list-style-type: none"> - Common air interface standard: J-STD-008 - Frequency: TX: 1850 - 1910MHx RX: 1930 - 1990MHx - TX Output Power: 316mW(25dBm) - RX Sensitivity: - 104dBm - Vocoder: 8K/13K QCELP 8K EVRC - Channel Bandwidth: CDMA 1.25Mhx - Spurious: TX Freq. Band: -61dBm below :RX Freq. Band: -81dBm below - MOD/DEMOD: OQPSK/QPSK - Frequency Accuracy: Fo+/-150Hz
Battery Back-up	<ul style="list-style-type: none"> - Type: Ni-Cd - Capacity: 8.4@1.7A - Talk Time: 2 Hours - Standby Time: 20 Hours
Connectors for Various Service Support	<ul style="list-style-type: none"> - RJ-11: standard wire-line telephone : Analog G3 Fax (Optional) - Serial port : Maintenance Purpose : Data Service Purpose (Internet, PC Fax)
Physical	<ul style="list-style-type: none"> - Dimension (DxWxH) : 226x166x65mm - Weight (including Backup battery): 995g
Environinental	<ul style="list-style-type: none"> - Operating temperature: -10°C ~ +50°C
Power Supply	<ul style="list-style-type: none"> - Input Power :110V~240V(±20)AC, 50/60Hx - Output Power: DC 12V@2A
Accessories	<ul style="list-style-type: none"> - Power Supply -