

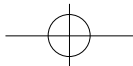

# Packard Bell A927

## User's Guide

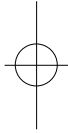
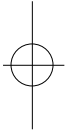
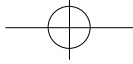
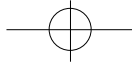

**U.S.A.****U.S.FEDERAL COMMUNICATIONS COMMISSION  
RADIO FREQUENCY INTERFERENCE STATEMENT  
INFORMATION TO THE USER**

NOTE : This equipment has been tested and found to comply with the limits for a Class B digital device pursuant to Part 15 of the FCC Rules.

These limits are designed to provide reasonable protection against harmful interference in a residential installation.

This equipment generates, uses, and can radiate radio frequency energy and, if not installed and used in accordance with the instructions, may cause harmful interference to radio communications.

However, there is no guarantee that interference will not occur in a particular installation.

If this equipment does cause harmful interference to radio or television reception, which can be determined by turning the equipment off and on, the user is encouraged to try to correct the interference by one or more of the following measures:

- Reorient or relocate the receiving antenna.
- Increase the separation between the equipment and receiver.
- Connect the equipment into an outlet of a circuit different from that to which the receiver is connected.
- Consult the dealer or an experienced radio/TV technician for assistance.

Changes or modification not expressly approved by the party responsible for compliance could void the user's authority to operate the equipment.

Connecting of peripherals requires the use of grounded, shielded signal cables.

## TCO 99

**Congratulations !** You have just purchased a TCO 99 approved and labelled product! Your choice has provided you with a product developed for professional use. Your purchase has also contributed to reducing the burden on the environment and also, to the further development of environmentally adapted electronics products.



### Why do we have environmentally labelled computers?

In many countries, environmental labelling has become an established method for encouraging the adaptation of goods and services to the environment. The main problem, as far as computers and other electronics equipment are concerned, is that environmentally harmful substances are used both in the products and during the manufacturing. Since it has not been possible for the majority of electronics equipment to be recycled in a satisfactory way, most of these potentially damaging substances sooner or later enter Nature.

There are also other characteristics of a computer, such as energy consumption levels, that are important from the viewpoints of both the work(internal) and natural(external) environments. Since all methods of conventional electricity generation have a negative effect on the environment(acidic and climate-influencing emissions, radioactive waste, etc.), it is vital to conserve energy. Electronics equipment in offices consume an enormous amount of energy since they are often left running continuously.

### What does labelling involve?

This product meets the requirements for the TCO 99 scheme which provides for international and environmental labelling of personal computers. The labelling scheme was developed as a joint effort by the TCO (The Swedish Confederation of Professional Employees), Naturskyddsforeningen (The Swedish Society for Nature Conservation) and NUTEK (The National Board for Industrial and Technical Development in Sweden). The requirements cover a wide range of issues: environment, ergonomics, usability, emission of electrical and magnetic fields, energy consumption and electrical and fire safety. The environmental demands concern restrictions on the presence and use of heavy metals, brominated and chlorinated flame retardants, CFCs (freons) and chlorinated solvents, among other things. The product must be prepared for recycling and the manufacturer is obliged to have an environmental plan which must be adhered to in each country where the company implements its operational policy.

The energy requirements include a demand that the computer and/or display, after a certain period of inactivity, shall reduce its power consumption to a lower level in one or more stages. The length of time to reactivate the computer shall be reasonable for the user. Labelled products must meet strict environmental demands, for example, in respect of the reduction of electric and magnetic fields, physical and visual ergonomics and good usability.

On the back page of this folder, you will find a brief summary of the environmental requirements met by this product. The complete environmental criteria document may be ordered from:

**TCO Development Unit**  
S-114 94 Stockholm  
Sweden  
Fax: +46 8 782 92 07  
Email (Internet) : development @ tco.se

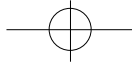

Current information regarding TCO ~~RE~~ approved and labelled products may also be obtained via the Internet, using the address:

<http://www.tco-info.com/>

TCO ~~RE~~ is a co-operative project between TCO (The Swedish Confederation of Professional Employees), Naturskyddsforeningen (The Swedish Society for Nature Conservation) and NUTEK (The National Board for Industrial and Technical Development in Sweden).

#### **Environmental Requirements Brominated flame retardants**

Brominated flame retardants are present in printed wiring boards, cables, wires, casings and housings. In turn, they delay the spread of fire. Up to thirty percent of the plastic in a computer casing can consist of flame retardant substances. These are related to another group of environmental toxins, PWBs, which are suspected to give rise to similar harm, including reproductive damage in fish eating birds and mammals, due to the bio-accumulative processes. Flame retardants have been found in human blood and researchers fear that disturbances in foetus development may occur.

*TCO ~~RE~~ demand requires that plastic components weighing more than 25 grams must not contain organically bound chlorine and bromine.*

#### **Lead\*\***

Lead can be found in picture tubes, display screens; solders and capacitors. Lead damages the nervous system and in higher doses, causes lead poisoning.

*TCO ~~RE~~ requirement permits the inclusion of lead since no replacement has yet been developed.*

#### **Cadmium\*\***

Cadmium is present in rechargeable batteries and in the colour generating layers of certain computer displays. Cadmium damages the nervous system and is toxic in high doses.

*TCO ~~RE~~ requirement states that batteries may not contain more than 25 ppm (parts per million) of cadmium. The colour-generating layers of display screens must not contain any cadmium.*

#### **Mercury\*\***

Mercury is sometimes found in batteries, relays and switches. Mercury damages the nervous system and is toxic in high doses.

*TCO ~~RE~~ requirement states that batteries may not contain more than 25 ppm (parts per million) of mercury. It also demands that no mercury is present in any of the electrical or electronics components concerned with the display unit.*

#### **CFCs (freons)**

CFCs (freons) are sometimes used for washing printed circuit boards and in the manufacturing of expanded foam for packaging. CFCs break down ozone and thereby damage the ozone layer in the stratosphere, causing increased reception on Earth of ultraviolet light with consequent increased risks of skin cancer (malignant melanoma).

*The relevant TCO ~~RE~~ requirement: Neither CFCs nor HCFCs may be used during the manufacturing of the product or its packaging.*

\* Bio-accumulative is defined as substances which accumulate within living organisms

\*\* Lead, Cadmium and Mercury are heavy metals which are Bio-accumulative.

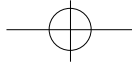

◦ .ENGLISH

Please check your power cord before installation if it is UL listed one.

◦ .FRANÇAIS

Veillez vérifier que votre cordon d'alimentation soit homologué UL avant l'installation.

◦ .ITALIANO

Prima di installare controllare che il cavo di alimentazione sia approvato UL.

◦ .DEUTSCH

Bitte prüfen Sie vor der Installation des Netzkabels, ob es in der UL-Liste aufgeführt ist.

◦ .ESPAÑOL

Compruebe el cable de potencia antes de la instalación si es uno de la lista UL.



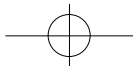
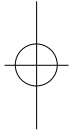
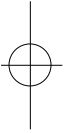
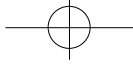

---

## Contents

Introduction .....	1
Safety Information .....	1
Installing the monitor .....	2
Packing List .....	2
Fastening the swivel and tilt base .....	3
Selecting a suitable location .....	3
Connecting the monitor .....	4
Setting the refresh rate .....	6
Preset Timing Table .....	6
Adjusting the picture. ....	7
Using the On Screen Display .....	7
OSD Adjustments .....	8
Display power management. ....	11
Reducing power consumption .....	11
Troubleshooting .....	12
Contacting service .....	13
Specifications .....	14



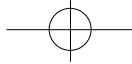

## Introduction

This manual contains instructions for installing and operating A927. A927 is a highly ergonomic color display unit;

- 19" diagonal (18" viewable) 0.26mm dot pitch CDT
- Supporting high screen refresh rates and full scan flicker-free picture quality
- With On Screen Display menus for user control
- 100-240V AC input voltage
- VESA DPMS (Display Power Management Signaling)
- VESA DDC1/2B compatibility

## Safety Information

When you set up and use your display unit, follow the safety instructions below.

- Do not use the display unit in humid environments like bathrooms, damp cellars, swimming pools, etc.
- This equipment must be connected to an earthed outlet which is close to the display unit and accessible in case you need to disconnect the display.
- Do not connect an extension cord.
- Never insert objects into the openings on the outside of the device as you can come into contact with live electrical components. This can cause fire or give strong electrical shocks.
- Slots in the cabinet are provided for ventilation. Do not block the ventilation slots in the display unit cabinet.
- Do not under any circumstances open the display unit cabinet.

## Cleaning and Maintenance

- To avoid risk of electric shock, do not disassemble the display unit cabinet. The unit is not user-serviceable. Remember to unplug the display unit from the power outlet before cleaning.
- Do not use alcohol (methyl, ethyl or isopropyl) or any strong dissolvent. Do not use thinner or benzene, abrasive cleaners or compressed air.
- Do not wipe the screen with a cloth or sponge that could scratch the surface.
- To clean your antistatic screen, use water and a special microfiber screen cleaning tissue used in optical lens cleaning, or lightly dampen a soft, clean cloth with water or a mild detergent.
- To clean display unit cabinet, use a cloth lightly dampened with a mild detergent.
- During the transportation of the monitor, the swivel base has to be removed in every case.

## User's Guide

---

### Installing the monitor

#### Packing List

The following items should be found in the packaging.

19" colour monitor

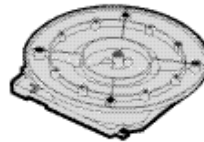

Tilt and Swivel



User's Guide



Signal Cable

**!** Above power cord can be changed upon different voltage areas. Please contact your dealer if anything is missing or damaged.

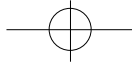

### Fastening the swivel and tilt base

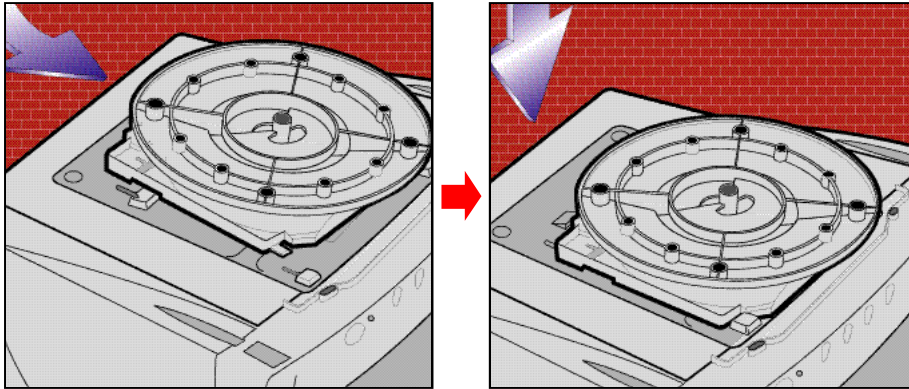

- Place the base against the bottom of the monitor so that the base fasteners are aligned with appropriate slots.
- Push the base towards the front of the monitor until the latch locks into position.

### Selecting a suitable location

- Place the monitor at least 30cm from other electrical or heat-emitting equipment and allow at least 10cm on each side for ventilation.
- Place the monitor in a position where no light shines directly onto or is reflected on the screen.
- To reduce eye strain, avoid installing the display unit against a bright background such as a window.
- Position the monitor so that the top of the screen is no higher than eye level.
- Position the monitor directly in front of you at a comfortable reading distance (around 45 to 90cm)

## User's Guide

### Connecting the monitor

**!** Before you start cabling your monitor, check that the power is off on all units. To avoid any possibility of electric shock, always connect your equipment to properly earthed outlets.

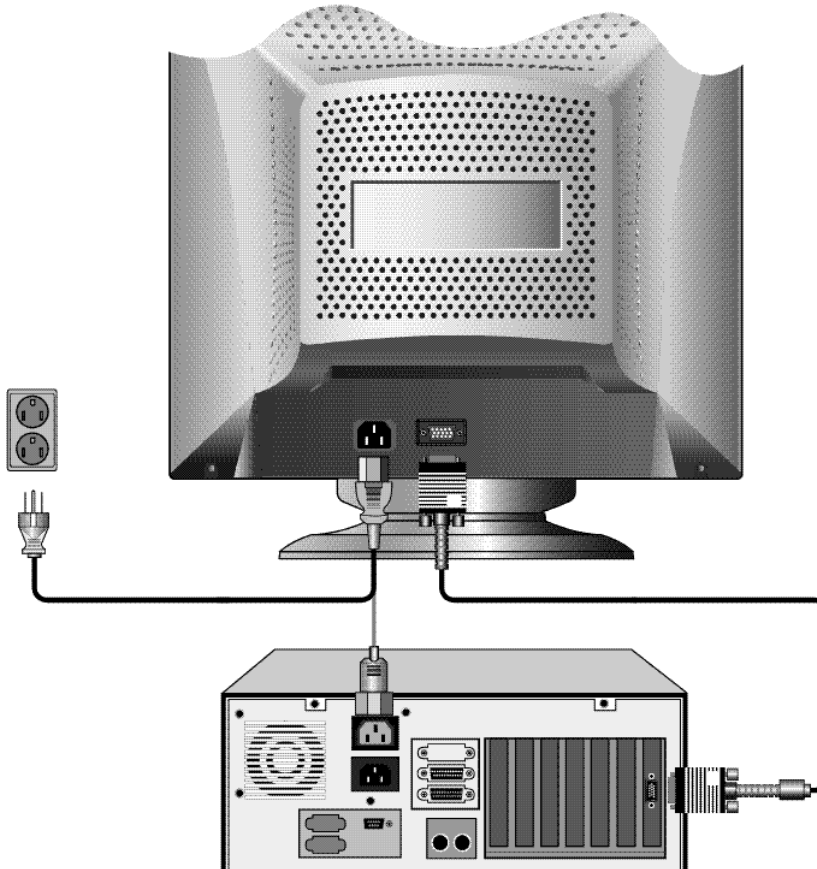

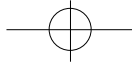

1. Insert the 15-pin signal cable connector to the VGA connection on your computer and screw it down.
2. Plug the display unit's power cable first to the back of the display unit.
3. Then plug the power cable to a 100V - 240V earthed electrical outlet or to the system unit, if it has an outlet for the display power cable.
4. Turn on the display unit using the power switch and check that the power LED is on. If not, repeat steps 2, 3 and 4 or refer to the Troubleshooting section of this guide.

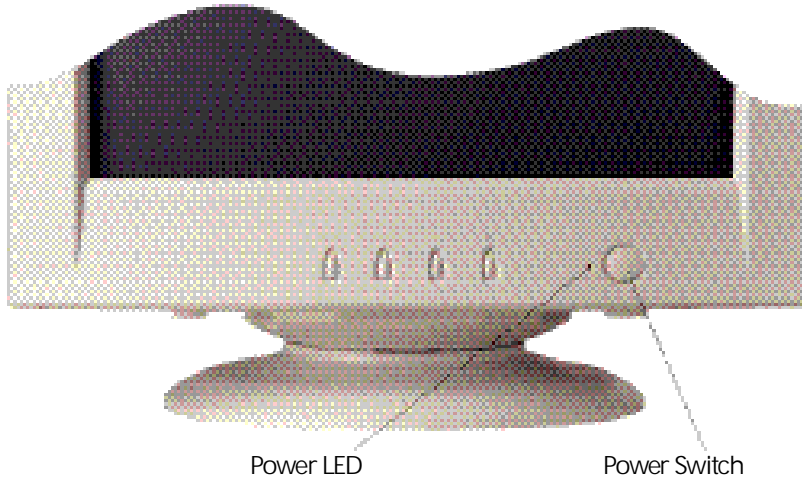

5. Turn on the power to the computer. The picture will appear within about 15 seconds. Adjust the picture to obtain optimum picture quality. See the section Adjusting the picture in this guide for more information.

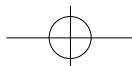

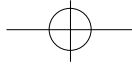

## User's Guide

---

### Setting the refresh rate

Follow the instructions below to set your refresh rate in Windows 98.

1. Go to the configuration window (Start-Settings-Configuration window).
2. Double click on the 'Display' icon.
3. Click on the 'Settings' tab.
4. Click on the 'Advanced' button.
5. Click on 'Adapter' and select 85Hz from the list.
6. Click on 'Apply' to accept the selected value.

The recommended setting is a resolution of 1280x1024(1600x1200) and a refresh rate of 85Hz(75Hz).

### Preset Timing Table

No.	Resolution	Horizontal Frequency	Refresh rate
1	720 x 400	31.5 KHz	70 Hz
2	640 x 480	31.5 KHz	60 Hz
3	640 x 480	63.7 KHz	120 Hz
4	800 x 600	53.7 KHz	85 Hz
5	1152 x 864	67.5 KHz	75 Hz
6	1024 x 768	68.7 KHz	85 Hz
7	1024 x 768	81.8 KHz	100 Hz
8	1280 x 1024	79.9 KHz	75 Hz
9	1280 x 1024	91.1 KHz	85 Hz
10	1600 x 1200	93.8 KHz	75 Hz

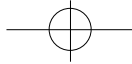

## Adjusting the picture

You can adjust the screen display by using the buttons located below the screen.

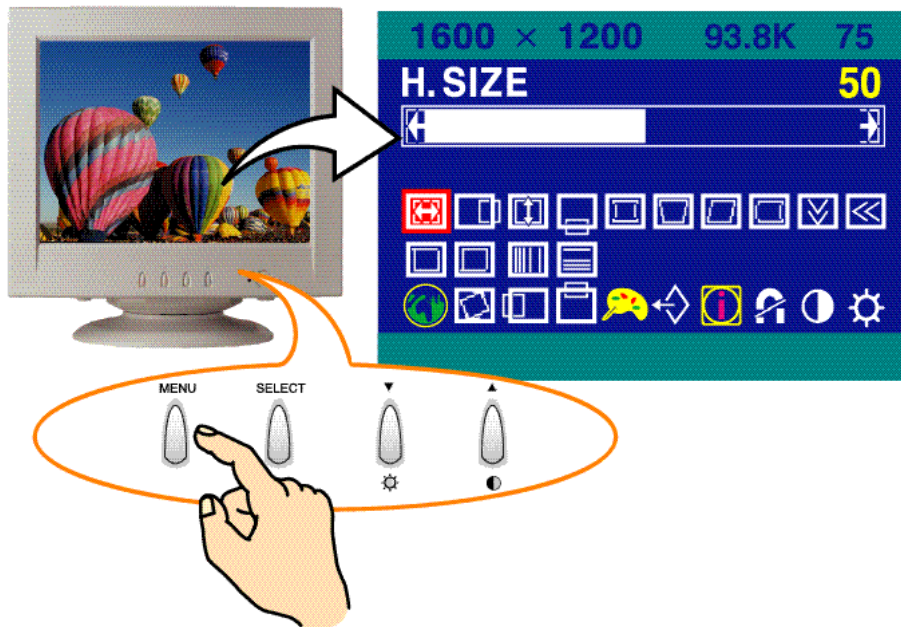

### Using the On Screen Display

1. Push the MENU button to call the OSD to the screen. The resolution and frequency are displayed at the top of the menu box for your information.
2. Push the  $\leftarrow$ ,  $\rightarrow$ ,  $\uparrow$ , or  $\downarrow$  button to choose the item you want to adjust. The selected item is highlighted.
3. Push the SELECT button to adjust the highlighted item.
4. Use the  $\leftarrow$ ,  $\rightarrow$ ,  $\uparrow$ , or  $\downarrow$  button to adjust the selection.
5. Push the MENU button to return to the previous menu if you are in a submenu.
6. The display unit automatically saves the new settings in 3 to 4 seconds after your last adjustments and the menu disappears. You can also push the MENU button to make the menu disappear.

Direct access buttons

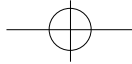

## User's Guide

---



### BRIGHTNESS

Use the button ▼ to select the brightness adjustment.  
Adjust with ▼ or ▲ button.



### CONTRAST

Use the button ▲ to select the contrast adjustment.  
Adjust with ▼ or ▲ button.

### OSD Adjustments

The OSD adjustments available to you are listed below.



#### H. SIZE

Adjusts the horizontal size of the entire screen image.



#### H. POSITION

Adjusts the horizontal position of the entire screen image.



#### V. SIZE

Adjusts the vertical size of the entire screen image.



#### V. POSITION

Adjusts the vertical position of the entire screen image.



#### PINCUSHION

If the vertical sides of the picture curve in or bulge out, you can correct the pincushion distortion by using this adjustment.



#### TRAPEZOID

If the picture is wider at the top or at the bottom, you can correct the trapezoid distortion by using this adjustment.



#### PARALLEL

If the sides of the screen image are tilted, you can correct the parallel distortion by using this adjustment.



#### PIN BALANCE

If the sides of the picture are bowed to the right or to the left, you can correct the pincushion balance by using this adjustment.



#### V. MOIRE

Clears vertical moire if a series of concentric circles or arcs appear on your screen.

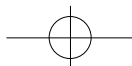



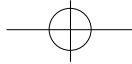

#### H. MOIRE

Clears horizontal moire if a series of concentric circles or arcs appear on your screen.

Moire is an interference pattern that makes the screen seem to have faint lines. A picture that is rasterised or consists of (small) repeating figures is sensitive to moire interference. Strong colors are also liable to intensify moire.

The moire pattern on the screen does not affect the printout of the image.



#### TOP CORNER

If the top corner sides of the picture curve in or bulge out, you can correct the top corner distortion by using this adjustment.



#### BOTTOM CORNER

If the bottom corner sides of the picture curve in or bulge out, you can correct the bottom corner distortion by using this adjustment.



#### H. LINEARITY

If either left or right side of the picture is out of proportion to the other, you can correct horizontal linearity by using this adjustment.



#### V. LINEARITY

If top and bottom side of the picture is out of proportion to the center area, you can correct vertical linearity by using this adjustment.



#### LANGUAGE

You can select the language in which adjustment menus are displayed. The following languages are available: English, French, German, Italian, Spanish, Swedish, Finnish, Danish and Portuguese.



#### ROTATION

If the entire screen image is tilted, you can correct the distortion by using this adjustment.



#### OSD H. POSITION

Adjusts the OSD menu's horizontal position on the screen.



#### OSD V. POSITION

Adjusts the OSD menu's vertical position on the screen.

User's Guide



COLOR CONTROL

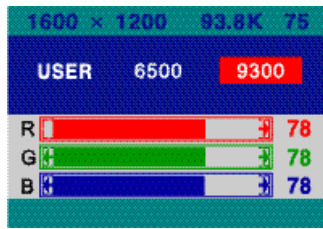

Color temperature affects the tint of the image. With lower color temperatures the image turns reddish and with higher temperatures bluish.

There are three color settings available: 9300K, 6500K or USER. With the USER setting you can set individual values for red, green and blue.



RECALL

If you operate your display unit in a factory preset mode, this function deletes adjustments you made for size, position and shape, and restores the properties which have been set in the factory. If you operate your display unit in a user mode, this function has no effect except that the contrast will be reset to the maximum value and the brightness to the cut-off level.



INFORMATION

Information shows horizontal and vertical sync polarity of current timing set.



DEGAUSS

External magnetic fields may cause distortion or discoloration in the picture. Demagnetizing takes place automatically when the display unit is switched on, and the unit normally maintains faultless color purity during operation.

If you have tilted, swiveled or moved the display unit, you can perform demagnetization. During this process the picture is distorted for a few seconds. After demagnetizing, the color impurities have disappeared if caused by stray magnetic fields.

Do not use the degauss feature more than once every half hour.



CONTRAST

Adjusts the contrast of the screen.



BRIGHTNESS

Adjusts the brightness of the screen.

## Display power management

If the power management function of your computer is enabled, your monitor turns on and off automatically. You can control power management features from your computer.

### Reducing power consumption

Your computer may have power management features which enable the computer or monitor to enter a power saving mode when the system is idle. You can reactivate the system by pressing any key or moving the mouse.

Mode	LED	Power consumption
Normal	Green	130 W
Standby	Green/Orange blinking (1sec.)	$\leq 15$ W
Suspend	Green/Orange blinking (0.5sec.)	$\leq 15$ W
off	Orange	$< 5$ W
Power switch off	Not illuminated	$< 1$ W
Unplugged	Not illuminated	0 W

**!** The power button at the front bezel does not disconnect the display unit from the mains. There are two ways to isolate the display unit completely from the mains supply.

User's Guide

Troubleshooting

If your monitor is not functioning properly, you may be able to solve the problem by reading followings.

Problem	Possible solution
Blank screen	<p>If the power LED is not lit, push the Power switch to turn the monitor on. If the display unit is powered through the computer, check that the computer is switched on.</p> <p>The display unit might be in standby mode. Push one of the keyboard keys. Check that the keyboard is properly connected to the computer.</p> <p>Check that the power cable is correctly connected to the display unit and to the power outlet.</p>
Error message: OUT OF RANGE	<p>The graphics adapter is set for too high refresh rate or line frequency. Select another display mode with lower frequencies in computer.</p>
Self diagnostics message NO SIGNAL	<p>This message indicates that the signal is missing or faulty. Check that the signal cable connector is properly connected and that the connection pins are not bent or damaged. If the connector is loose, tighten the connector's screws.</p>
The display does not enter power management mode	<p>The video signal from the computer does not comply with VESA DPMS standard. Either the computer or the graphics adapter is not using the VESA DPMS power management function.</p>
Screen flickers	<p>The screen may seem to flicker when the refresh rate is less than 75Hz. See the list of recommended modes in the section Preset timing table.</p>
Color defects	<p>If your color is not uniform, demagnetize the display unit as described in the section Degauss under OSD adjustments, and make sure that the display unit is at least 30cm from any other electrical equipment.</p> <p>Check that the signal cable connector is properly connected and that the connection pins are not bent or damaged. Try another color temperature.</p> <p>If the picture has strong color defects, switch off the display unit and the computer.</p>

Problem	Possible solution
Size, position, shape or quality unsatisfactory	Make sure that other electrical devices are at least quality 30cm away. Adjust the picture characteristics as described in the section Adjusting the picture.
Duplicated images	A problem with your graphics adapter or display unit. Contact your service representative.

#### Contacting service

If the above troubleshooting hints do not help you find a solution to the problem, contact an authorized service agent. If the monitor is sent for service, use the original package if possible.

Unplug the display unit from the power outlet and contact a service agent when:

- The monitor does not operate normally according to the operating instructions.
- The monitor exhibits a distinct change in performance.
- The monitor has been dropped or the cabinet has been damaged.
- The monitor has been exposed to rain, or water or liquid has been spilled onto the monitor.

User's Guide

Specifications

Picture tube	19"(viewable size : 18") Dot pitch 0.26 mm Anti-Static, anti-glare, TCO treatment coated.
Display area	factory preset area : 352X264 mm
Number of color	Infinite
Input signals	R.G.B Analog, 15 pin D-sub
Frequency rate	Horizontal : 30 to 95kHz, Vertical : 50 to 150Hz
Maximum bandwidth	202.5 MHz
Maximum resolution	1600X1200@75Hz
Input voltage	100-240 VAC, 2.5A
Power consumption	130W Max
Power Management	VESA DPMS
Plug & Play	Lower than EPA recommendation VESA DDC 1/2B
OSD menu	H/V SIZE, H/V POSITION, PINCUSHION, TRAPEZOID, PARALLEL, PIN BALANCE, H/V- MOIRE, TOP CORNER, BOTTOM CORNER, H/V LINEARITY, LANGUAGES, ROTATION, OSD H/V POSITION, COLOR CONTROL, RECALL, INFORMATION, DEGAUSS, BRIGHTNESS, CONTRAST
Ergonomics, Safety and EMC	TCO FCC Class B, CE UL, CSA, TÜV-GS, ISO-9241-3/7/8, DHHS, NEMKO, DEMKO, FIMKO, SEMKO
Operating Temperature	0 ~ 40°C
Weight	22.5kg unpacked, 26kg packed
Dimensions (W X H X D mm)	446X465.5X468.5mm

- Specification is subject to change without notice for performance improvement.