

---

■ Memory channels .....	8-2
■ Memory channel selection .....	8-2
◇ Using the [▲]/[▼] keys .....	8-2
◇ Using the keypad .....	8-2
■ Memory list screen .....	8-3
◇ Selecting a memory channel using the memory list screen .....	8-3
◇ Confirming programmed memory channels .....	8-3
■ Memory channel programming .....	8-4
◇ Programming in VFO mode .....	8-4
◇ Programming in memory mode .....	8-4
■ Frequency transferring .....	8-5
◇ Transferring in VFO mode .....	8-5
◇ Transferring in memory mode .....	8-5
■ Memory names .....	8-6
◇ Editing (programming) memory names .....	8-6
■ Memory clearing .....	8-6
■ Memo pads .....	8-7
◇ Writing frequencies and operating modes into memo pads .....	8-7
◇ Calling up a frequency from a memo pad .....	8-7

## Memory channels

The transceiver has 101 memory channels. The memory mode is very useful for quickly changing to often-used frequencies.

All 101 memory channels are tuneable which means the programmed frequency can be tuned temporarily with the main dial, etc. in memory mode.

MEMORY CHANNEL	MEMORY CHANNEL NUMBER	CAPABILITY	TRANSFER TO VFO	OVER-WRITING	CLEAR
Regular memory channels	1–99	One frequency and one mode in each memory channel.	Yes	Yes	Yes
Scan edge memory channels	P1, P2	One frequency and one mode in each memory channel as scan edges for programmed scan.	Yes	Yes	No

## Memory channel selection

### Using the [▲]/[▼] keys

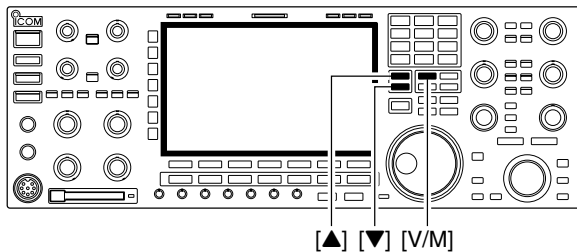

- ① Push [V/M] to select memory mode.
- ② Push [▲]/[▼] several times to select the desired memory channel.
  - Push and hold [▲]/[▼] for continuous selection.
  - [UP] and [DN] on the microphone can also be used.
- ③ To return to VFO mode, push [V/M] again.

### Using the keypad

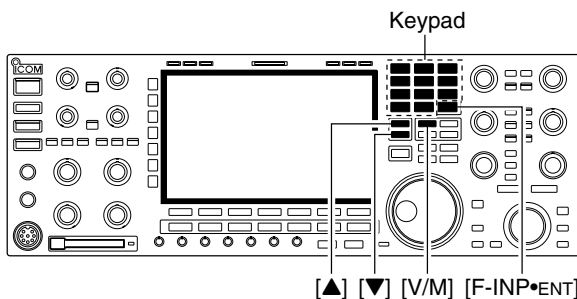

- ① Push [V/M] to select memory mode.
- ② Push [F-INP•ENT].
- ③ Push the desired memory channel number using the keypad.
  - Enter 100 or 101 to select scan edge channel P1 or P2, respectively.
- ④ Push [▲] or [▼] to select the desired memory channel.

#### [EXAMPLE]

- To select the memory channel 3;
  - Push [F-INP•ENT], [7•3], then push [▲] or [▼].
- To select the memory channel 12;
  - Push [F-INP•ENT], [1.8•1], [3.5•2], then push [▲] or [▼].
- To select the scan edge channel P1;
  - Push [F-INP•ENT], [1.8•1], [50•0], [50•0], then push [▲] or [▼].
- To select the scan edge channel P2;
  - Push [F-INP•ENT], [1.8•1], [50•0], [1.8•1], then push [▲] or [▼].

## Memory list screen

The memory list screen simultaneously shows 9 memory channels and their programmed contents. 15 memory channels can be displayed in the wide memory list screen.

You can select a desired memory channel from memory list screen.

### Selecting a memory channel using the memory list screen

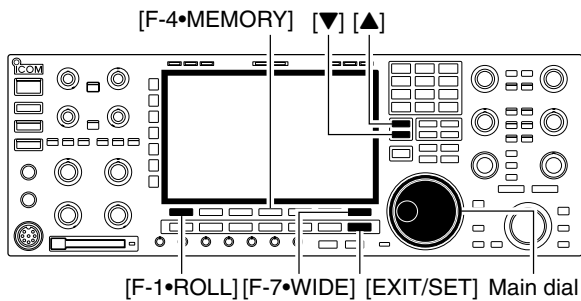

- ① Push [EXIT/SET] several times to close a multi-function screen, if necessary.
- ② Push [F-4•MEMORY] to select memory list screen.
  - [F-7•WIDE] switches the standard and wide screens.
- ③ While pushing [F-1•ROLL], rotate the main dial to select the desired memory channel.
  - [▲] and [▼] can also be used.
- ④ Push [EXIT/SET] to exit memory list screen.

#### Memory list screen



### Confirming programmed memory channels

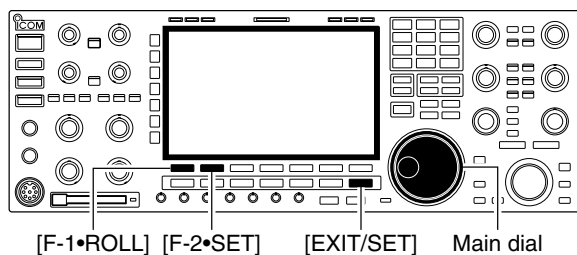

- ① Select memory list screen as described above.
- ② While pushing [F-1•ROLL], rotate the main dial to scroll the screen.
- ③ Push [F-2•SET] to select the highlighted memory channel, if desired.
  - “▶” appears beside the selected memory channel number in the memory list screen and the selected memory channel contents are displayed below the frequency readout.
- ④ Push [EXIT/SET] to exit memory list screen.

## Memory channel programming

### Programming in VFO mode

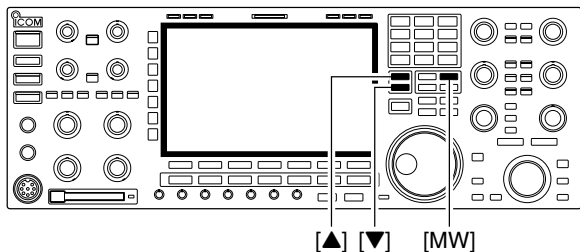

[EXAMPLE]: Programming 7.088 MHz/LSB into memory channel 12.

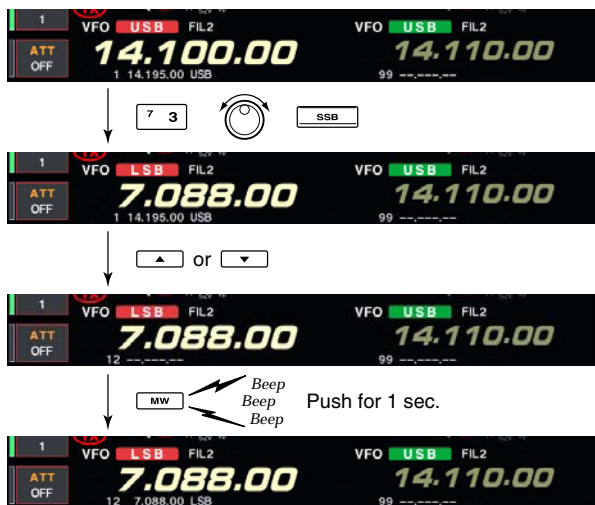

### Programming in memory mode

[EXAMPLE]: Programming 21.280 MHz/USB into memory channel 18.



Memory channel programming can be performed either in VFO mode or in memory mode.

- ① Set the desired frequency, operating mode and filter width in VFO mode.
- ② Push [▲]/[▼] several times to select the desired memory channel.
  - Memory list screen is convenient for selecting the desired channel.
  - Memory channel contents appear in the memory channel readout (below the frequency readout).
  - “-.-.-.-” appears if the selected memory channel is a blank channel (and does not have contents).
- ③ Push [MW] for 1 sec. to program the displayed frequency and operating mode into the memory channel.

- ① Select the desired memory channel with [▲]/[▼] in memory mode.
  - Memory channel contents appear in the memory channel readout (below the frequency readout).
  - “-.-.-.-” appears if the selected memory channel is a blank channel (and does not have contents).
- ② Set the desired frequency and operating mode in memory mode.
  - To program a blank channel, use direct frequency entry with the keypad or memo pads, etc.
- ③ Push [MW] for 1 sec. to program the displayed frequency and operating mode into the memory channel.

## ■ Frequency transferring

### ◇ Transferring in VFO mode

#### TRANSFERRING EXAMPLE IN VFO MODE

Operating frequency : 21.320 MHz/USB (VFO)

Contents of M-ch 16 : 14.018 MHz/CW

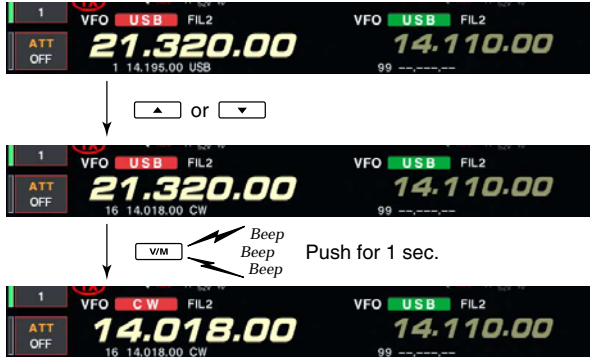

### ◇ Transferring in memory mode

#### TRANSFERRING EXAMPLE IN MEMORY MODE

Operating frequency : 21.320 MHz/USB (M-ch 16)

Contents of M-ch 16 : 14.018 MHz/CW

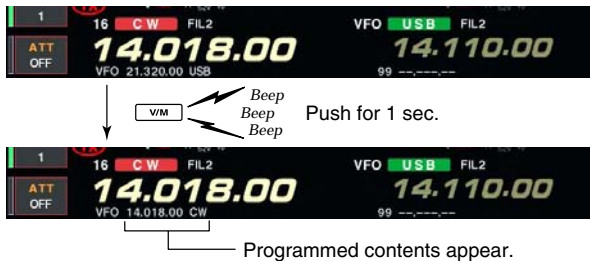

The frequency and operating mode in a memory channel can be transferred to the VFO.

Frequency transferring can be performed in either VFO mode or memory mode.

This is useful for transferring programmed contents to VFO.

- ① Select VFO mode with [V/M].
- ② Select the memory channel to be transferred with [▲]/[▼].
  - Memory list screen is convenient for selecting the desired channel.
  - Memory channel contents appear in the memory channel readout (below the frequency readout).
  - “-.-.-.-” appears if the selected memory channel is a blank channel. In this case transferring is impossible.
- ③ Push [V/M] for 1 sec. to transfer the frequency and operating mode.
  - Transferred frequency and operating mode appear on the frequency readout.

This is useful for transferring frequency and operating mode while operating in memory mode.

When you have changed the frequency or operating mode in the selected memory channel:

- **Displayed** frequency, mode and filter setting are transferred.
- **Programmed** frequency and mode in the memory channel are not transferred, and they remain in the memory channel.

- ① Select the memory channel to be transferred with [▲]/[▼] in memory mode.
  - And, set the frequency or operating mode if required.
- ② Push [V/M] for 1 sec. to transfer the frequency and operating mode.
  - Displayed frequency and operating mode are transferred to the VFO.
- ③ To return to VFO mode, push [V/M] momentarily.

## Memory names

All memory channels (including scan edges) can be tagged with alphanumeric names of up to 10 characters each.

Capital letters, small letters, numerals, some symbols (! # \$ % & ¥ ? " ' ` ^ + - \* / . , ; = < > ( ) [ ] { } | \_ ~ @) and spaces can be used.

### Editing (programming) memory names

[ABC]/[abc] [123]/[Symbol] [F-3•DEL] Keypad

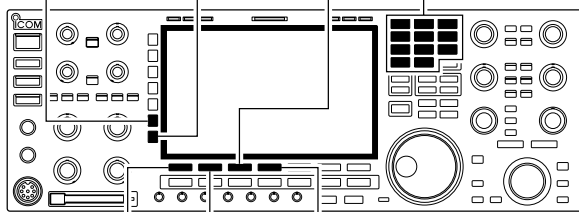

[F-1•◀] [F-2•▶] [F-4•SPACE]



- ① Push [EXIT/SET] several times to close a multi-function screen, if necessary.
- ② Push [F-4•MEMORY] to select memory list screen.
- ③ Select the desired memory channel.
- ④ Push [F-4•NAME] to edit memory channel name.
  - A cursor appears and blinks.
  - Memory channel names of blank channels cannot be edited.
- ⑤ Input the desired character by rotating the main dial or by pushing the band key for number input.
  - Push [ABC] or [abc] to toggle capital and small letters.
  - Push [123] or [Symbol] to toggle numerals and symbols.
  - Push [F-1•◀] or [F-2•▶] for cursor movement.
  - Push [F-3•DEL] to delete the selected character.
  - Push [F-4•SPACE] to input a space.
  - Pushing the transceiver's keypad, [0]–[9], can also enter numerals.
- ⑥ Push [EXIT/SET] to input and set the name.
  - The cursor disappears.
- ⑦ Repeat steps ③ to ⑥ to program another memory channel's name, if desired.
- ⑧ Push [EXIT/SET] to exit memory list screen.

## Memory clearing

Any unnecessary memory channels can be cleared. The cleared memory channels become blank channels.

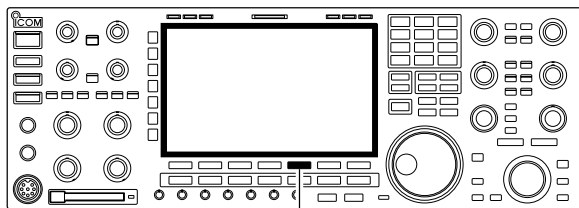

[F-5•CLR]

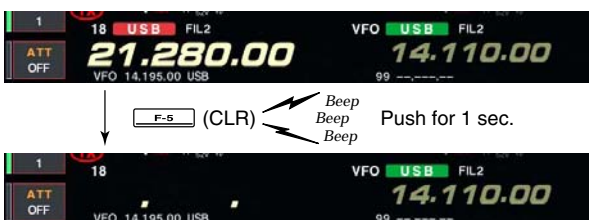

- ① Select memory mode with [V/M].
- ② Push [F-4•MEMORY] to select memory list screen.
- ③ Select the desired memory channel with [▲]/[▼].
- ④ Push [F-5•CLR] for 1 sec. to clear the contents.
  - The programmed frequency and operating mode disappear.
- ⑤ To clear other memory channels, repeat steps ③ and ④.

## ■ Memo pads

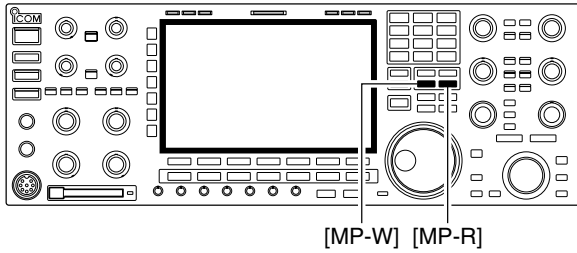

The transceiver has a memo pad function to store frequency and operating mode for easy write and recall. The memo pads are separate from memory channels.

The default number of memo pads is 5, however, this can be increased to 10 in set mode if desired. (p. 12-16)

Memo pads are convenient when you want to memorize a frequency and operating mode temporarily, such as when you find a DX station in a pile-up, or when a desired station is busy for a long time and you want to temporarily search for other stations.

Use the transceiver's memo pads instead of relying on hastily scribbled notes that are easily misplaced.

### ◇ Writing frequencies and operating modes into memo pads

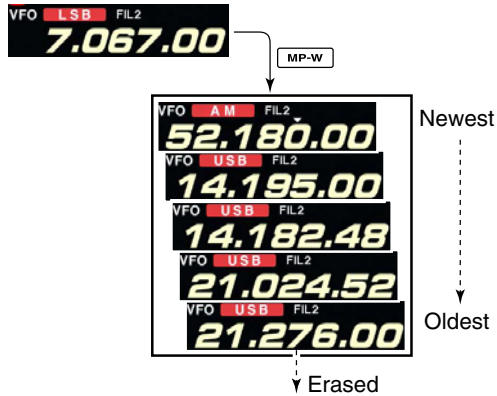

In this example, 21.276 MHz (LSB) will be erased when 7.067 MHz (LSB) is written.

You can simply write the accessed readout frequency and operating mode by pushing [MP-W].

When you write a 6th frequency and operating mode, the oldest written frequency and operating mode are automatically erased to make room for the new settings.

Each memo pad must have its own unique combination of frequency and operating mode; memo pads having identical settings cannot be written.

### ◇ Calling up a frequency from a memo pad

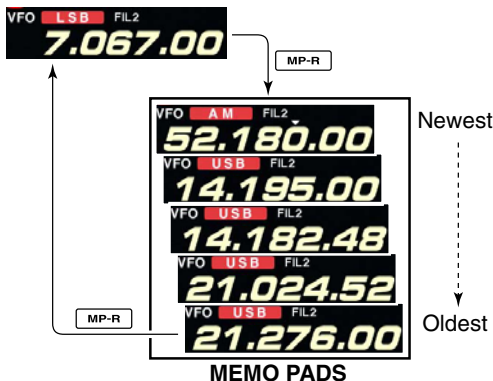

You can simply call up the desired frequency and operating mode of a memo pad by pushing [MP-R] several times.

- Both VFO and memory modes can be used.
- The frequency and operating mode are called up, starting from the most recently written.

When you call up a frequency and an operating mode from memo pads with [MP-R], the previously displayed frequency and operating mode are automatically stored in a temporary pad. The frequency and operating mode in the temporary pad can be recalled by pushing [MP-R] several times.

- You may think there are 6 memo pads because 6 different frequencies (5 are in memo pads and 1 is in the temporary pad) are called up by [MP-R].

If you change the frequency or operating mode called up from a memo pad with the main dial, etc., the frequency and operating mode in the temporary pad are erased.

■ Scan types .....	9-2
■ Preparation .....	9-2
■ Voice squelch control function .....	9-3
■ Scan set mode .....	9-3
■ Programmed scan operation .....	9-4
■ $\Delta F$ scan operation .....	9-4
■ Fine programmed scan/ $\Delta F$ scan .....	9-5
■ Memory scan operation .....	9-6
■ Select memory scan operation .....	9-6
■ Setting select memory channels .....	9-7
◇ Setting in scan screen .....	9-7
◇ Setting in memory list screen .....	9-7
◇ Erasing the select scan setting .....	9-7
■ Tone scan .....	9-8



## Scan types

- The scan function can be used on the main read-out only.
- You can operate a scan while operating on a frequency using the dualwatch or split functions.

### PROGRAMMED SCAN

Repeatedly scans between two scan edge frequencies (scan edge memory channels P1 and P2).

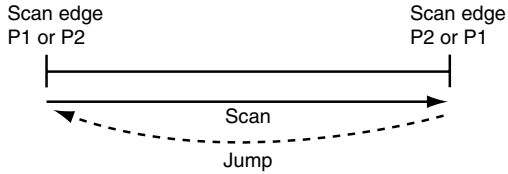

This scan operates in VFO mode.

### ΔF SCAN

Repeatedly scans within ΔF span area.

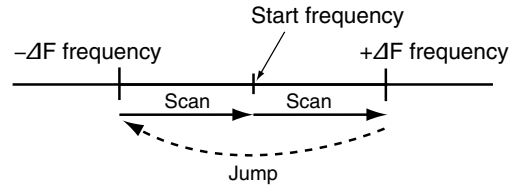

This scan operates in both VFO and memory modes.

### MEMORY SCAN

Repeatedly scans all programmed memory channels.

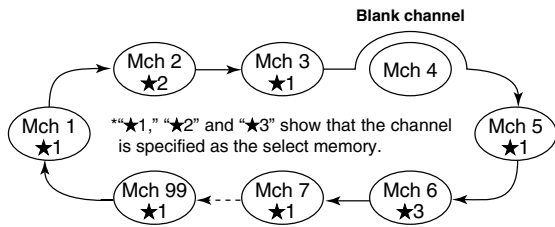

This scan operates in memory mode.

### SELECT MEMORY SCAN

Repeatedly scans all or one of 3 select memory channels.

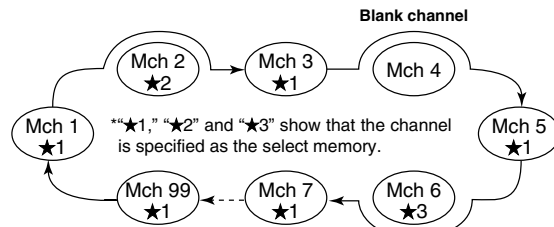

This scan operates in memory mode.

## Preparation

### • Channels

*For programmed scan:*

Program scan edge frequencies into scan edge memory channels P1 and P2.

*For ΔF scan:*

Set the ΔF span (ΔF scan range) in the scan screen.

*For memory scan:*

Program 2 or more memory channels except scan edge memory channels.

*For select memory scan:*

Designate 2 or more memory channels as select memory channels. To designate the channel as a select memory channel, choose a memory channel, then push [F-3•SELECT] in the scan screen (memory mode) or in the memory list screen.

### • Scan resume ON/OFF

You can select the scan to resume or cancel when detecting a signal, in set mode. Scan resume ON/OFF must be set before operating a scan. See p. 9-3 for ON/OFF setting and scan resume condition details.

### • Scan speed

Scan speed can be selected from 2 levels, high or low, in scan set mode. See p. 9-3 for details.

### • Squelch condition

SCAN STARTS WITH	PROGRAMMED SCAN	MEMORY SCAN
SQUELCH OPEN	The scan continues until it is stopped manually, and does not pause even if it detects signals.	Scan pauses on each channel when the scan resume is ON; not applicable when OFF.
SQUELCH CLOSED	Scan stops when detecting a signal. If you set scan resume ON in set mode, the scan pauses for 10 sec. when detecting a signal, then resumes. When a signal disappears while scan is paused, scan resumes 2 sec. later.	

## ■ Voice squelch control function

This function is useful when you don't want unmodulated signals pausing or cancelling a scan. When the voice squelch control function is activated, the receiver checks received signals for voice components.

If a receiver signal includes voice components, and the tone of the voice components changes within 1 sec., scan pauses (or stops). If the received signal includes no voice components or the tone of the voice components does not change within 1 sec., scan resumes.

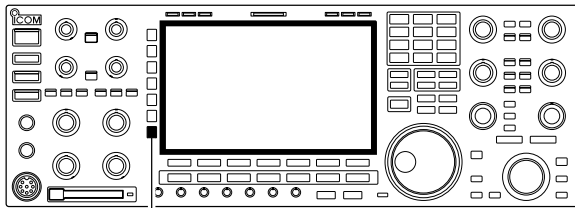

[VSC]

- While a phone mode (SSB, AM or FM) is selected, push [VSC] to switch the VSC (Voice Squelch Control) function ON and OFF.
  - "VSC" appears when the function is activated.

- ▨ • The VSC function activates for any scan.
- ▨ • The VSC function resumes the scan on unmodulated signals, regardless of whether the scan resume condition is set to ON or OFF.

## ■ Scan set mode

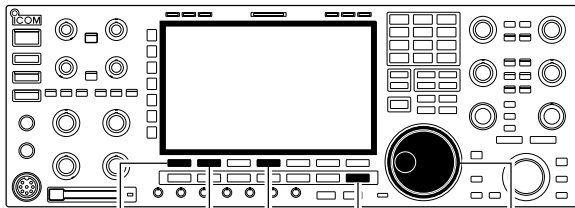

[F-1•▲] [F-2•▼] [F-4•DEF] [EXIT/SET] Main dial

When the squelch is open, scan continues until it is stopped manually—it does not pause on detected signals. When squelch is closed, scan stops when detecting a signal, then resumes according to the scan resume condition. Scan speed and the scan resume condition can be set using the scan set mode.

- ① Push [F-5•SCAN] to select scan screen.
- ② Push [F-7•SET] to select scan set mode.
- ③ Push [F-1•▲] or [F-2•▼] to select the desired item.
- ④ Rotate the main dial to select the desired condition.
  - Push [F-4•DEF] for 1 sec. to select the default setting.
- ⑤ Push [EXIT/SET] to return to scan menu.



<b>SCAN Speed</b>	<b>HIGH</b>
Select the desired scan speed from high and low.	<ul style="list-style-type: none"> <li>• HIGH : scan is faster</li> <li>• LOW : scan is slower</li> </ul>

<b>SCAN Resume</b>	<b>ON</b>
Set the scan resume function ON and OFF.	<ul style="list-style-type: none"> <li>• ON : When detecting a signal, scan pauses for 10 sec., then resumes. When a signal disappears, scan resumes 2 sec. later.</li> <li>• OFF : When detecting a signal, cancels scanning.</li> </ul>

## Programmed scan operation

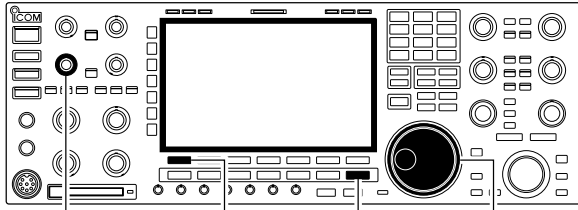

[SQL] for main [F-1•PROG] [EXIT/SET] Main dial



- ① Push [EXIT/SET] several times to close a multi-function screen, if necessary.
- ② Select VFO mode.
- ③ Select the desired operating mode.
  - The operating mode can also be changed while scanning.
- ④ Push [F-5•SCAN] to select the scan screen.
- ⑤ Set the main band's [SQL] open or closed.
  - See page 9-2 for squelch condition.
- ⑥ Push [F-1•PROG] to start the programmed scan.
  - "PROGRAM SCAN" and decimal points blink while scanning.
- ⑦ When the scan detects a signal, the scan stops, pauses or ignores it depending on the resume setting and the squelch condition.
- ⑧ To cancel the scan, push [F-1•PROG].
  - Rotating the main dial also cancels the scan.
- ⑨ Push [F-6•RECALL] for 1 sec. to recall the frequency that is set before starting the scan, if desired.

/// If the same frequencies are programmed into the scan edge memory channel P1 and P2, programmed scan does not start.

## $\Delta$ F scan operation

[F-4• $\Delta$ F SPAN]

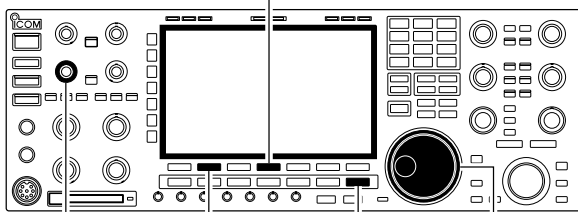

[SQL] for main [F-2• $\Delta$ F] [EXIT/SET] Main dial



- ① Push [EXIT/SET] several times to close a multi-function screen, if necessary.
- ② Select VFO mode or a memory channel.
- ③ Select the desired operating mode.
  - The operating mode can also be changed while scanning.
- ④ Push [F-5•SCAN] to select the scan screen.
- ⑤ Set the main band's [SQL] open or closed.
  - See page 9-2 for squelch condition.
- ⑥ Set the  $\Delta$ F span by pushing [F-4• $\Delta$ F SPAN].
  - $\pm 5$  kHz,  $\pm 10$  kHz,  $\pm 20$  kHz,  $\pm 50$  kHz,  $\pm 100$  kHz,  $\pm 500$  kHz and  $\pm 1000$  kHz are selectable.
- ⑦ Set center frequency of the  $\Delta$ F span.
- ⑧ Push [F-2• $\Delta$ F] to start the  $\Delta$ F scan.
  - " $\Delta$ F SCAN" and decimal points blink while scanning.
- ⑨ When the scan detects a signal, the scan stops, pauses or ignores it depending on the resume setting and the squelch condition.
- ⑩ To cancel the scan, push [F-2• $\Delta$ F].
  - Rotating the main dial also cancels the scan.
- ⑪ Push [F-6•RECALL] for 1 sec. to recall the frequency that is set before starting the scan, if desired.

## ■ Fine programmed scan/fine $\Delta F$ scan

Fine scan functions as programmed or  $\Delta F$  scan, but scan speed decreases when the squelch opens but does not stop. The scanning tuning step shifts from 50 Hz to 10 Hz while the squelch opens.

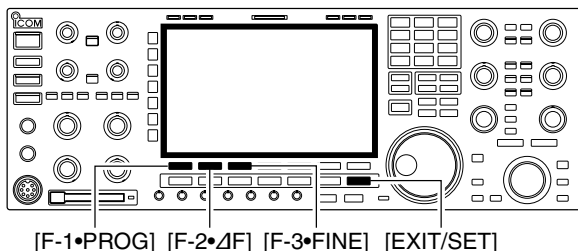

- ① Push [EXIT/SET] several times to close a multi-function screen, if necessary.
- ② Push [F-5•SCAN] to select the scan screen.
- ③ Set for programmed scan or  $\Delta F$  scan as described on previous page.
- ④ Push [F-1•PROG] or [F-2• $\Delta F$ ] to start a scan.
  - “PROGRAM SCAN” or “ $\Delta F$  SCAN” and decimal points blink while scanning.
- ⑤ Push [F-3•FINE] to start a fine scan.
  - “FINE PROGRAM SCAN” or “FINE  $\Delta F$  SCAN” blinks instead of “PROGRAM SCAN” or “ $\Delta F$  SCAN,” respectively.
- ⑥ When the scan detects a signal, the scan speed decreases but does not stop.
- ⑦ Push [F-1•PROG] or [F-2• $\Delta F$ ] to stop the scan; push [F-3•FINE] to cancel the fine scan.
  - Rotating the main dial also cancels the scan.
- ⑧ Push [F-6•RECALL] for 1 sec. to recall the frequency that is set before starting the scan, if desired.



## Memory scan operation

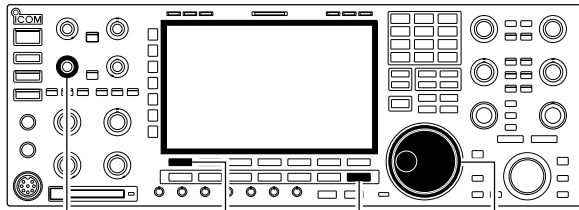

[SQL] for main [F-1•MEMO] [EXIT/SET] Main dial



- ① Push [EXIT/SET] several times to close a multi-function screen, if necessary.
- ② Select memory mode.
- ③ Push [F-5•SCAN] to select the scan screen.
- ④ Set the main band's [SQL] open or closed.
  - See page 9-2 for squelch condition.
- ⑤ Push [F-1•MEMO] to start the memory scan.
  - "MEMORY SCAN" and decimal points blink while scanning.
- ⑥ When the scan detects a signal, the scan stops, pauses or ignores it depending on the resume setting and the squelch condition.
- ⑦ To cancel the scan, push [F-1•MEMO].
  - Rotating the main dial also cancels the scan.

2 or more memory channels must be programmed for memory scan to start.

## Select memory scan operation

[F-3•SELECT] [F-5•SEL No.]

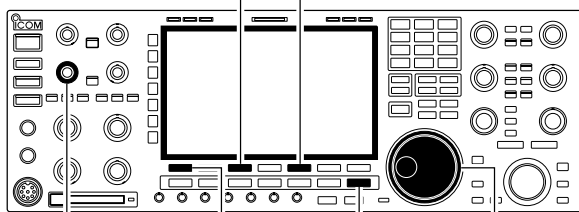

[SQL] for main [F-1•MEMO] [EXIT/SET] Main dial



- ① Push [EXIT/SET] several times to close a multi-function screen, if necessary.
- ② Select memory mode.
- ③ Push [F-5•SCAN] to select the scan screen.
- ④ Set the main band's [SQL] open or closed.
  - See page 9-2 for squelch condition.
- ⑤ Push [F-5•SEL No.] several times to select the select scan number from ★1, ★2, ★3 and ★1/★2/★3.
- ⑥ Push [F-1•MEMO] to start the memory scan.
  - "MEMORY SCAN" and decimal points blink while scanning.
- ⑦ Push [F-3•SELECT] to start select memory scan; push [F-3•SELECT] again to return to memory scan, if desired.
  - "SELECT MEMORY SCAN" blinks instead of "MEMORY SCAN" during select memory scan.
- ⑧ When the scan detects a signal, the scan stops, pauses or ignores it depending on the resume setting and the squelch condition.
- ⑨ To cancel the scan, push [F-1•MEMO].
  - Rotating the main dial also cancels the scan.

2 or more memory channels must be designated as select memory channels, as well as the same select scan number, for select memory scan to start.



## ■ Setting select memory channels

### ◇ Setting in scan screen



- ① Push [EXIT/SET] several times to close a multi-function screen, if necessary.
- ② Select memory mode.
- ③ Push [F-5•SCAN] to select the scan screen.
- ④ Select the desired memory channel to set as a select memory channel.
  - [▲]/[▼] keys and direct keypad selections can be used.
- ⑤ Push [F-3•SELECT] several times to set the memory channel as a select memory ★1, ★2, ★3 or not.
- ⑥ Repeat steps ④ to ⑤ to program another memory channel as a select memory channel, if desired.
- ⑦ Push [EXIT/SET] to exit the scan screen.

### ◇ Setting in memory list screen



- ① Push [EXIT/SET] several times to close a multi-function screen, if necessary.
- ② Push [F-4•MEMORY] to select memory list screen.
- ③ Rotate the main dial while pushing [F-1•ROLL] or [F-2•SET] to select the desired memory channel.
  - [▲]/[▼] keys and direct keypad selections can be used.
- ④ Push [F-3•SELECT] several times to set the memory channel as a select memory ★1, ★2, ★3 or not.
- ⑤ Repeat steps ③ to ④ to program another memory channel as a select memory channel, if desired.
- ⑥ Push [EXIT/SET] to exit the memory list screen.

### ◇ Erasing the select scan setting



- ① Push [EXIT/SET] several times to close a multi-function screen, if necessary.
- ② Push [F-4•MEMORY] to select memory list screen, or push [F-5•SCAN] to select scan screen.
- ③ Push [F-3•SELECT] for 1 sec. to display memory select all clear window.
- ④ Push one of the following keys to clear all select scan setting.
  - [F-1•★1] : Clears all ★1 setting.
  - [F-2•★2] : Clears all ★2 setting.
  - [F-3•★3] : Clears all ★3 setting.
  - [F-4•★1,2,3] : Clears all select setting.
- ⑤ Push [EXIT/SET] to exit the memory list screen.

## ■ Tone scan

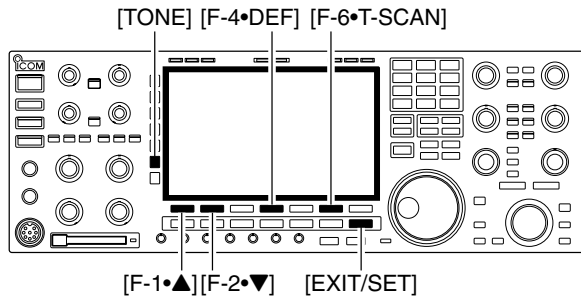

The transceiver can detect the subaudible tone frequency in a received signal. By monitoring a signal that is being transmitted on a repeater input frequency, you can determine the tone frequency required to access the repeater.

- ① Set the desired frequency or memory channel to be checked for a tone frequency.
- ② Push [AM/FM] several times to select FM mode.
- ③ Push [TONE] for 1 sec. to enter tone frequency screen.
- ④ Push [F-1•▲] or [F-2•▼] to check the repeater tone frequency or tone squelch frequency, respectively.
- ⑤ Push [F-6•T-SCAN] to start the tone scan.
  - "SCAN" blinks while scanning.
- ⑥ When the tone frequency is detected, the tone scan pauses.
  - The tone frequency is set temporarily on a memory channel. Program into the memory channel to store the tone frequency permanently.
  - The decoded tone frequency is used for the repeater tone frequency or tone squelch frequency.
- ⑦ To stop the scan, push [F-6•T-SCAN].
  - Push [F-4•DEF] for 1 sec. to select the default frequency.
- ⑧ Push [EXIT/SET] to exit tone frequency screen.

■ Antenna connection and selection .....	10-2
■ Antenna memory settings .....	10-3
◇ Antenna type selection .....	10-3
◇ Temporary memory .....	10-4
◇ Antenna selection mode .....	10-4
■ Antenna tuner operation .....	10-5
◇ Tuner operation .....	10-5
◇ If the tuner cannot tune the antenna .....	10-6



## ■ Antenna connection and selection

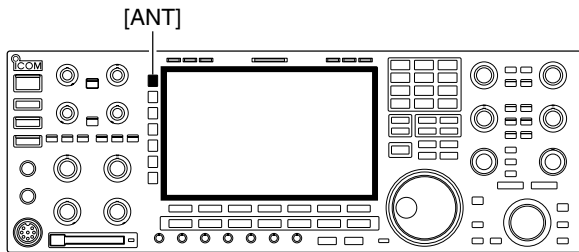

The IC-7800 has 4 antenna connectors for the HF/50 MHz bands, [ANT1], [ANT2], [ANT3], and [ANT4].

For each operating band the IC-7800 covers, there is a band memory which can memorize a selected antenna. When you change the operating frequency beyond a band, the previously used antenna is automatically selected (see below) for the new band. This function is convenient when you use 4 antennas for HF and 50 MHz bands operation.

### • Antenna selection mode: “Auto”

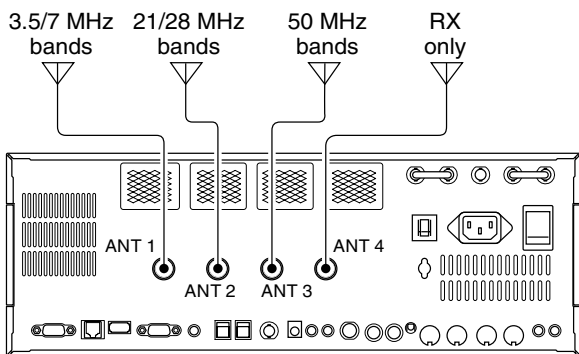

Once an antenna has been selected for use with a band by pushing [ANT], the antenna is automatically selected whenever that band is accessed.

**[EXAMPLE]:** a 3.5/7 MHz antenna is connected to [ANT1], a 21/28 MHz antenna is connected to [ANT2], a 50 MHz antenna is connected to [ANT3]. When the antenna selector function is set to “Auto,” an antenna is automatically selected when changing bands. [ANT4] can be used for receive only.

### • Antenna selection mode: “Manual”

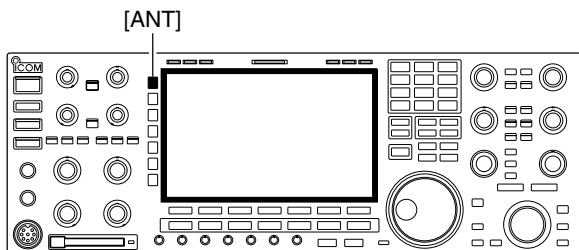

When “Manual” is selected, you can use the all antenna connectors, [ANT1] [ANT2], [ANT3] and [ANT4], however, band memory does not function. In this case you must select an antenna manually.

### • Antenna selection mode: “OFF”

In this case, only [ANT1] antenna connector can be used. [ANT] switch does not function.

## ■ Antenna memory settings

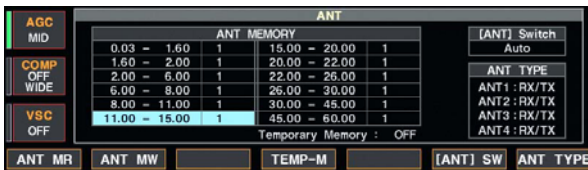
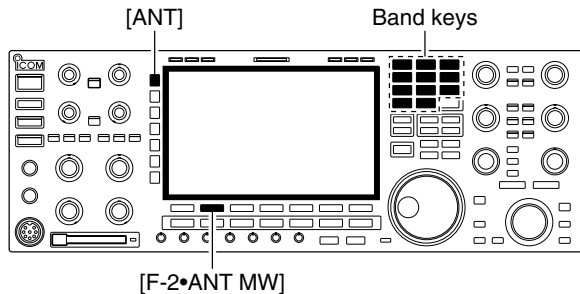

Storing the antenna connector number for each frequency band to suit your antenna system.

- ① Push [EXIT/SET] several times to close multi-function screen, if necessary.
- ② Push [ANT] for 1 sec. to select antenna set screen.
- ③ Select the desired frequency band with a band key.
- ④ Push [ANT] several times to select the desired antenna number that you want to set for the selected frequency band.
  - “★” appears.
- ⑤ Push [F-2•ANT MW] for 1 sec. to store the antenna selection into the antenna memory.
  - “★” disappears.
- ⑥ Repeat the steps ③ to ⑤ to store the antenna selection for another frequency bands, if desired.
- ⑦ Push [EXIT/SET] to exit antenna set screen.

## ◇ Antenna type selection



When no antenna is connected to [ANT2], [ANT3], and/or [ANT4], these antenna connector can be deactivated— deleting the antenna number from selection. This prevent the transceiver from accidental transmission with unmatched antenna selection. In addition, receive only antenna can be specified to [ANT4].

- ① Select the antenna set screen as described above.
- ② Push [F-7•ANT TYPE] to select antenna type set screen.
- ③ Push [F-1•▲] or [F-2•▼] to select the desired antenna.
- ④ Rotate the main dial to select the desired antenna condition from TX/RX, RX (ANT4 only) and OFF.
  - TX/RX : Select when an antenna is connected.
  - OFF : Select when no antenna is connected.
  - RX : Select when a receive only antenna is connected. (available for the [ANT4] only)
- ⑤ Push [EXIT/SET] to exit antenna type set screen.

### ✓ For your information

The antenna(s) that “OFF” is selected cannot be selected with [ANT] switch operation, as well as the antenna memory setting.

When “RX” is selected for [ANT4], “1/R,” “2/R” and “3/R” selections will be added for the selection for both [ANT] switch operation and the antenna memory setting. In these selection, using the antenna connected to [ANT1], [ANT2] and/or [ANT3] for transmission and using the antenna connected to [ANT4] for reception.

■ Antenna memory settings (continued)

◇ Temporary memory



“★” appears when a different antenna from the original is selected.

Push [F-4•TEMP-M] to turn the temporary memory ON and OFF.

The antenna temporary memory memorize the manually selected antenna. The selected antenna will be recalled even the frequency band has been changed.

- ① Select the antenna set screen.
- ② Push [F-4•TEMP-M] to turn the temporary memory ON and OFF.
- ③ Select the desired frequency band with a band key.
- ④ Push [ANT] to select the desired antenna.
  - “★” appears when a different antenna from the original is selected.
- ⑤ Push [F-1•ANT MR] to re-call the original antenna.
  - “★” disappears.
- ⑥ Push [EXIT/SET] to exit antenna set screen.

**CAUTION!** Before transmitting with the manually selected antenna, make sure the selected antenna suits to the operating frequency. Otherwise the transceiver may damage.

◇ Antenna selection mode



Push [F-6•[ANT] SW] to select the antenna selection mode.

The automatic antenna selection (antenna memory) and the [ANT] switch function can be deactivated if desired.

- ① Select the antenna set screen.
- ② Push [F-6•[ANT] SW] to select the antenna selection from Auto, OFF and Manual.
  - Auto : Use the antenna memory. Antenna selection with [ANT] switch is also available.
  - OFF : The antenna connected to [ANT1] can only be used. [ANT] switch is deactivated.
  - Manual : Deactivate the antenna memory function. Antenna can be selected with [ANT] switch operation only.
- ③ Push [EXIT/SET] to exit antenna set screen.

## ■ Antenna tuner operation

The internal automatic antenna tuner matches the transceiver to the connected antenna automatically. Once the tuner matches an antenna, the variable capacitor angles are memorized as a preset point for each frequency range (100 kHz steps). Therefore, when you change the frequency range, the variable capacitors are automatically preset to the memorized point.

**CAUTION:** NEVER transmit with the tuner ON when no antenna is connected. This will damage the transceiver. Be careful of the antenna selection.

### ◇ Tuner operation

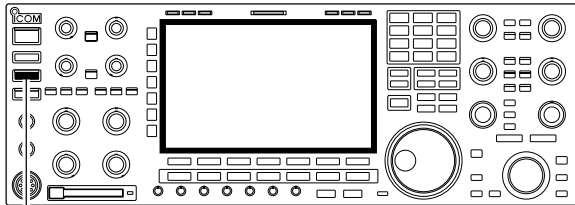

[TUNER]

- ➔ Push [TUNER] to turn the internal antenna tuner ON. The antenna is tuned automatically when the antenna SWR is higher than 1.5:1.
  - When the tuner is ON, the "TUNE" indicator appears.

#### NOTES:

- NEVER transmit without an antenna properly connected to antenna port in use.
- When 2 or more antennas are connected, select the antenna to be used with [ANT].
- If the SWR is higher than about 1.5:1 when tuning above 100 kHz on an antenna's preset point, push [TUNER] for 1 sec. to start manual tuning.
- The internal tuner may not be able to tune in AM mode. In such cases, push [TUNER] for 1 sec. to manually tune.

#### • MANUAL TUNING

During SSB operation at low voice levels, the internal tuner may not be tuned correctly. In such cases, manual tuning is helpful.

- ➔ Push [TUNER] for 1 sec., to start manual tuning.
  - A side tone is emitted and "TUNE" indicator blinks while tuning.
  - If the tuner cannot reduce the SWR to less than 1.5:1 after 20 sec. of tuning, the [TUNER] switch indicator goes out.

#### • AUTOMATIC TUNER START (HF bands only)

If you want to deactivate the tuner under conditions of VSWR 1.5:1 or less, use the auto tuner start function and turn the tuner OFF. This function activates the tuner automatically when the SWR exceeds 1.5:1.

This function is turned ON in set mode. (p. 12-14).

## ■ Antenna tuner operation (continued)

### • PTT TUNER START

The tuner is always tuned when the PTT is pushed after the frequency is changed (more than 1% from last-tuned frequency). This function removes the “push and hold [TUNER]” operation and activates for the first transmission on a new frequency.

This function is turned ON in set mode. (p. 12-14).

### • Antenna tuner of the IC-PW1

When using an external antenna tuner such as the IC-PW1's tuner, tune with the external antenna tuner, while the internal tuner is turned OFF. After tuning is completed, turn the internal tuner ON. Otherwise, both tuners tune simultaneously and correct tuning may not be obtained.

See the instruction manual included with each antenna tuner for their respective operations.

## ◇ If the tuner cannot tune the antenna

Check the following and try again:

- the [ANT] connector selection.
- the antenna connection and feedline.
- the unaltered antenna SWR. (Less than 3:1 for HF bands; Less than 2.5:1 for 50 MHz band)
- the transmit power. (8 W for HF bands; 15 W for 50 MHz band)
- the power source voltage/capacity.

If the tuner cannot reduce the SWR to less than 1.5:1 after checking the above, perform the following:

- repeat manual tuning several times.
- tune with a 50  $\Omega$  dummy load and re-tune the antenna.
- turn power OFF and ON.
- adjust the antenna cable length.  
(This is effective for higher frequencies in some cases.)
- Some antennas, especially for low bands, have a narrow bandwidth. These antennas may not be tuned at the edge of their bandwidth, therefore, tune such an antenna as follows:

**[Example]:** Suppose you have an antenna which has an SWR of 1.5:1 at 3.55 MHz and an SWR of 3:1 at 3.8 MHz.

- ① Push [TUNER] to turn the antenna tuner ON.
- ② Select CW mode.
- ③ Turn OFF the break-in function. (p. 6-3)
- ④ Push [TRANSMIT] to set to the transmit condition.
- ⑤ Set 3.55 MHz and key down.
- ⑥ Set 3.80 MHz and key down.
- ⑦ Push [TRANSMIT] to return to the receive condition.

■ Time set mode .....	11-2
■ Daily timer setting .....	11-3
■ Setting sleep timer .....	11-4
■ Timer operation .....	11-4

## Time set mode

[ABC]/[abc] [123]/[Symbol] [F-3•◀▶] [F-5•EDIT]/[F-5•SET]

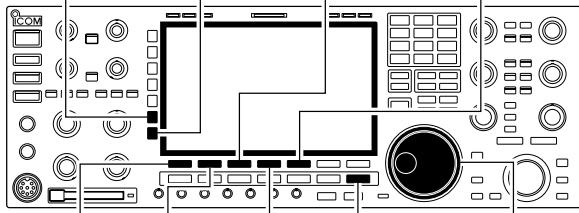

[F-1•▲] [F-2•▼] [F-4•DEF] [EXIT/SET] Main dial

The IC-7800 has a built-in calendar and 24-hour clock with daily power ON/OFF timer functions. Before operating these timer functions, set the current date and time, etc.

- ① Push [EXIT/SET] to close multi-function screen, if necessary.
- ② Push [F-7•SET] to select set mode menu screen.
- ③ Push [F-4•TIME] to select time set mode.
- ④ Push [F-1•▲] or [F-2•▼] to select the desired item.
- ⑤ Rotate the main dial to set or select the desired value or condition.
- ⑥ Push [EXIT/SET] to exit time set mode.

<b>Date</b>	<b>2000- 1- 1 ( Sat )</b>
Sets the date.	<ol style="list-style-type: none"> <li>① Push [F-3•◀▶] to select between the year and the month/day, then rotate the main dial to select them. <ul style="list-style-type: none"> <li>• The date setting and “DATE-set Push [SET]” indication blink.</li> </ul> </li> <li>② Push [F-5•SET] to set the date.</li> </ol>

<b>Time (Now)</b>	<b>1:23</b>
Sets the local time.	<ol style="list-style-type: none"> <li>① Rotate the main dial to set the local time. <ul style="list-style-type: none"> <li>• The time setting and “TIME-set Push [SET]” indication blink.</li> </ul> </li> <li>② Push [F-5•SET] to set the time.</li> </ol>

<b>CLOCK2 Function</b>	<b>ON</b>
Turns the clock 2 indication ON and OFF. The clock 2 is convenient to indicate the UTC or other country’s local time, etc.	<ul style="list-style-type: none"> <li>• ON : The clock 2 is displayed below the local time indication.</li> <li>• OFF : The clock 2 does not display.</li> </ul>

<b>CLOCK2 Offset</b>	<b>± 0:00</b>
Sets the desired off-set time period for the clock 2 indication within -24:00 to +24:00 in 1 min. steps.	<ul style="list-style-type: none"> <li>• Pushing [F-4•DEF] for 1 sec. to select the default value.</li> </ul>

<b>CLOCK2 Name</b>	<b>UTC</b>
Sets the desired 3-character name for the clock 2.  Capital letters, small letters, numerals, some symbols (! # \$ % & ¥ ? " ' ` ^ + - * / . , ; = < > ( ) [ ] { }   _ ~ @) and spaces can be used.	<ol style="list-style-type: none"> <li>① Push [F-5•EDIT] to select the name edit condition. <ul style="list-style-type: none"> <li>• The 1st character and cursor blink.</li> </ul> </li> <li>② Push [ABC], [abc], [123] or [Symbol] to select the character group, then rotate the main dial to select the character. <ul style="list-style-type: none"> <li>• Push [ABC] or [abc] to toggle capital and small letters.</li> <li>• Push [123] or [Symbol] to toggle numerals and symbols.</li> <li>• Push [F-1•◀] or [F-2•▶] for cursor movement.</li> <li>• Push [F-3•DEL] to delete the selected character.</li> <li>• Push [F-4•SPACE] to input a space.</li> <li>• Pushing the transceiver’s keypad, [0]–[9], can also enter numerals.</li> </ul> </li> <li>③ Push [EXIT/SET] to set the name.</li> </ol>

## ■ Daily timer setting

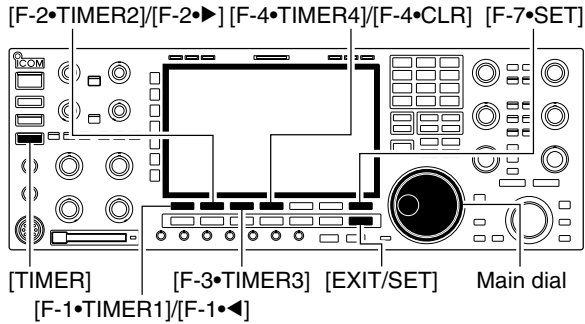

The transceiver turns power ON and/or OFF automatically on the specified day of the week and time with the specified frequency settings in each main and sub readout.

- ① Push [EXIT/SET] several times to close multi-function screen, if necessary.
- ② Push [TIMER] for 1 sec. to select timer set screen.
- ③ Push one of [F-1•TIMER1] to [F-4•TIMER4] to select the desired timer.
- ④ Rotate the main dial to select the timer action ON and OFF.
- ⑤ Push [F-2•▶] to select the “DAY” cell, then rotate the main dial to select the desired day of the week.
  - Select “---” to not specifying the day of the week. The timer will function every day in this case.
  - Once a day of the week is selected, push [F-4•CLR] for 1 sec. to select “---.”
- ⑥ Push [F-2•▶] to select the “REPEAT” cell, then rotate the main dial to select the repeat function ON and OFF.
  - ON : The timer functions every selected day of the week.
  - OFF : The timer functions only coming day of the week.
- ⑦ Push [F-2•▶] to select the “ON” cell, then rotate the main dial to set the desired transceiver power ON time.
  - When using power OFF timer only, push [F-4•CLR] for 1 sec. to select “---.”
- ⑧ Push [F-2•▶] to select the “OFF” cell, then rotate the main dial to set the desired transceiver power OFF time.
  - When using power ON timer only, push [F-4•CLR] for 1 sec. to select “---.”
- ⑨ Push [F-2•▶] to select the “MAIN” cell, then rotate the main dial to select the desired memory channel number in the main readout.
  - If using the currently set VFO condition in main readout, push [F-4•CLR] for 1 sec. to select “---.”
- ⑩ Push [F-2•▶] to select the “SUB” cell, then rotate the main dial to select the desired memory channel number in the sub readout.
  - If using the currently set VFO condition in sub readout, push [F-4•CLR] for 1 sec. to select “---.”
- ⑪ Push [F-7•SET] to set the timer.
  - The timer indicator above [TIMER] switch lights green.
- ⑫ Repeat the steps ③ to ⑪ to set another timers, if desired.
- ⑬ Push [EXIT/SET] to exit timer set screen.



## ■ Setting sleep timer

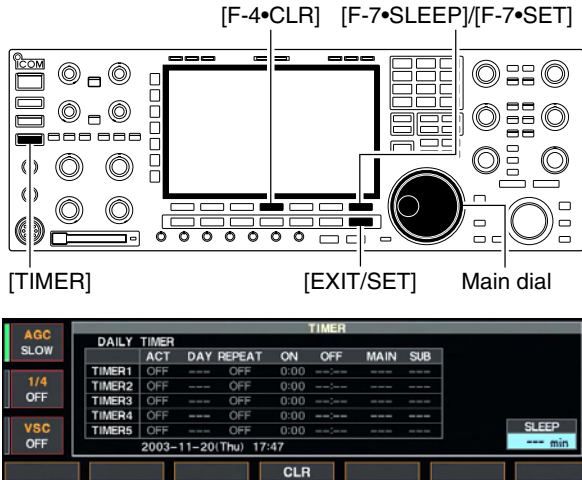

The sleep timer turns the transceiver power OFF automatically after passing the set period. The timer can be set to 5–120 min. in 5 min. steps.

- ① Push [EXIT/SET] several times to close a multi-function screen, if necessary.
- ② Push [TIMER] for 1 sec. to select timer set screen.
- ③ Push [F-7•SLEEP] to select the sleep timer set condition.
  - “---” blinks.
- ④ Set the desired time period using the main dial.
  - “TIMER-set Push [SET]” blinks.
  - Push [F-4•CLR] to select “---” to cancel the setting.
- ⑤ Push [F-7•SET] to set the time.
  - Push [EXIT/SET] to cancel the setting.
  - The timer indicator above [TIMER] switch lights green.
- ⑥ Push [EXIT/SET] to exit timer set screen.
- ⑦ The transceiver emits 10 beeps and turns OFF after the sleep timer period elapses.
  - The timer indicator blinks while beeping.
  - Push [TIMER] momentarily to cancel the sleep timer, if desired.

## ■ Timer operation

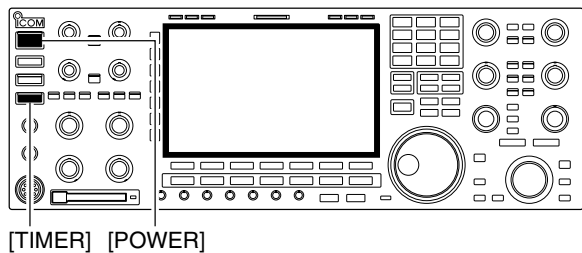

- ① Preset the daily timer as described previously.
- ② Push [TIMER] momentarily to turn the timer function ON.
  - The timer indicator above this switch lights green when the timer function is ON.
- ③ Push [POWER] for 1 sec. to turn the power OFF.
  - The timer indicator lights continuously.
- ④ When the set time arrives, the power is automatically turned ON.
- ⑤ The transceiver emits 10 beeps and turns OFF after the power-off period elapses.
  - The timer indicator blinks while beeping.
  - Push [TIMER] momentarily to cancel the sleep timer, if desired.

/// The timer action in timer set screen must be selected ON to enable the timer operation, described in page 11-3 steps ④.