

### ■ Priority watch operation

- ① Select VFO mode; then, set an operating frequency.
- ② Set the watching channel(s).  
**For memory channel watch:**  
Select the desired memory channel.  
**For memory scan watch:**  
Select memory mode; then, push [V/MHz•SCAN] for 1 sec. to start memory scan.  
**For call channel watch:**  
Select the desired call channel by pushing [M/CALL•PRIO] once or twice, then push [BAND].
- ③ Push [M/CALL•PRIO] for 1 sec. to start the watch.
  - The transceiver checks the memory or call channel every 5 sec.
  - The watch resumes according to the selected scan resume condition. (p. 45)
  - While the watch is pausing, pushing [M/CALL•PRIO] resumes the watch manually.
- ④ Push [M/CALL•PRIO] for 1 sec. to stop the watch.



- ① Select VFO mode; then, set the desired frequency.
- ② Set the watching channel(s).  
**For memory channel watch:**  
Push [MR/CALL] then [▲] or [▼] to select the desired memory channel.  
**For memory scan watch:**  
Push [MR/CALL], then push [SCAN 2] to start the memory scan.  
**For call channel watch:**  
Push [MR/CALL] for 1 sec. then push [BAND] to select the call channel.
- ③ Push [PRIO 3(PTT-M)] to start the watch.
  - The transceiver checks the memory or call channel every 5 sec.
  - The watch resumes according to the selected scan resume condition. (p. 45)
  - To resume the watch manually when paused, push [PRIO 3(PTT-M)] or [CLR A(MW)].
- ④ To stop the watch, push [CLR A(MW)] once (or twice while watch is paused).

## ■ Programming a DTMF code

DTMF tones are used for autopatching, controlling other equipment, etc. The transceiver has 16 DTMF memory channels (D0–Df) for storage of often-used DTMF codes of up to 24 digits.

- ① Push [MONI•DTMF] for 1 sec. to turn the DTMF encoder ON.
  - “d” appears in place of 100 MHz digit.
- ② Push [SET•LOCK] to enter the DTMF memory programming condition.
  - The DTMF memory channel indication blinks.
- ③ Rotate [DIAL] to select the desired DTMF memory channel.
- ④ Push [SET•LOCK].
  - The first digit blinks.
- ⑤ Rotate [DIAL] to select the desired code.
- ⑥ Push [SET•LOCK] to select the next digit.
  - Pushing [S.MW•MW] moves the cursor backward.
- ⑦ Repeat the steps ⑤ and ⑥ to set the desired DTMF tone sequence.
  - The S/R/F indicator shows the digit group. The indication increases every 6 digits.
- ⑧ Push [MONI•DTMF] to exit DTMF memory programming condition.
  - Return to the previous indication as in step ①.

**[EXAMPLE]:** Programming “5428A3” into DTMF memory channel “D4.”

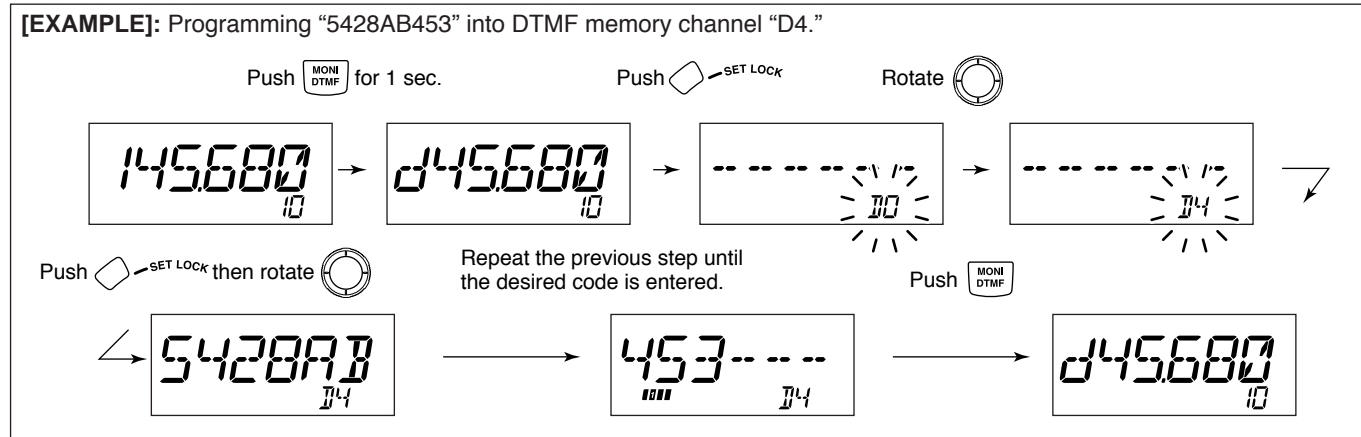

## 9 DTMF MEMORY ENCODER

### ◇ Programming a DTMF code— via microphone



- 1 Push [FUNC] then [Low 6(DTMF)] to turn the DTMF encoder ON.
  - “d” appears in place of 100 MHz digit.
- 2 Push [SET B(D-OFF)] to enter the DTMF memory programming condition.
- 3 Push [▲] or [▼] to select the desired DTMF memory channel.
- 4 Push the desired digit keys.
  - When the first digit is input, previous memory contents are cleared automatically.
  - “E” stands for “\*” and “F” stands for “#.”
  - Push [▲]/[▼] and repeat this step if you make a mistake.
  - The S/RF indicator shows the digit group. The indication increases every 6 digits.

- 5 Push [VFO/LOCK] to exit the programming condition.
  - The [CLR A(MW)] key cannot be used to exit. If pushed, code “A” is input. Reprogram in such a case.

[EXAMPLE]: Programming “5428A8” into DTMF memory channel “D4.”

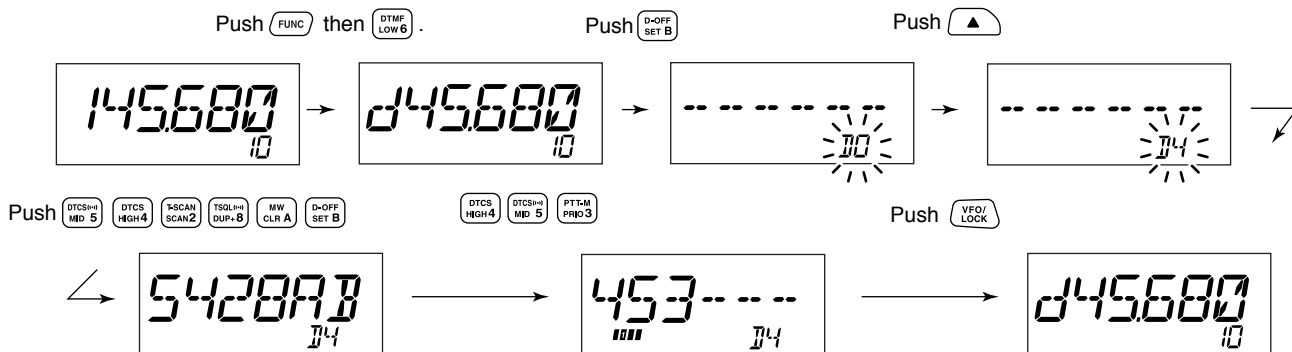

## ■ Transmitting a DTMF code

### ◇ Automatic transmission (DTMF memory)

- ① Push [MONI•DTMF] for 1 sec. to turn the DTMF memory encoder ON.
  - “d” appears in place of 100 MHz digit.
- ② Push [SET•LOCK] to enter DTMF memory programming condition.
- ③ Rotate [DIAL] to select the desired DTMF memory channel.
- ④ Push [PTT] to transmit the selected DTMF memory content.
- ⑤ Push [MONI•DTMF] for 1 sec. to cancel the DTMF encoder.
  - When the DTMF encoder is turned ON continuously, each push of the PTT transmits the previously selected DTMF code.



- ① Push [FUNC] then [Low 6(DTMF)] to turn the DTMF memory encoder ON.
  - “d” appears in place of 100 MHz digit.
- ② Push [SET B(D-OFF)] to enter the DTMF memory programming condition.
- ③ Push [▲] or [▼] to select the desired channel.
- ④ Push [PTT] to transmit the selected memory.
  - Exit the programming condition automatically.
  - Each push of [PTT] transmits the DTMF code.
- ⑤ Push [FUNC] then [SET B(D-OFF)] to cancel the DTMF memory encoder.
  - When the DTMF encoder is turned ON continuously, each push of the PTT transmits the previously selected DTMF code.

### ◇ Transmitting a DTMF memory directly



- ① Push [FUNC] then [Low 6(DTMF)] to turn the DTMF memory encoder ON.
    - “d” appears in place of 100 MHz digit.
  - ② Push [DTMF-S] to turn the DTMF memory direct selection ON.
    - The function indicator (microphone) lights green.
  - ③ Push the desired DTMF channel.
    - “0” to “9” and “A” to “D” are available for DTMF memory channels.
    - The selected DTMF code is automatically transmitted without pushing PTT.
- NOTE:** When no DTMF code programmed channel number is pushed, it transmits the relative DTMF code as the manual transmission described in the next page.
- ④ Push [DTMF-S] again to deactivate the DTMF memory direct selection.
  - ⑤ Push [FUNC] then [SET B(D-OFF)] to cancel the DTMF memory encoder.

## 9 DTMF MEMORY ENCODER

### ◇ Manual transmission



- 1 Deactivate the DTMF memory encoder by pushing [FUNC] then [SET B(D-OFF)].
- 2 Push [DTMF-S] to turn the DTMF direct selection ON.
  - The function indicator (microphone) lights green.
- 3 Push one of “0” to “9” and “A” to “F” keys momentarily, then push the desired DTMF keys, 0–9 and A to F.
  - A: [CLR A(MW)]                      B: [SET B(D-OFF)],
  - C: [ENT C(T-OFF)]                  D: [SQL▲ D(MUTE)],
  - E: [\* (TONE-1)]                    F: [SQL▼ # (16KEY-L)]
  - Automatically transmits without pushing PTT.
  - The first code, one of “0” to “9” and “A” to “F,” is not transmitted. DTMF code transmission starts from the 2nd code.
- 4 Push [DTMF-S] again to deactivate the DTMF direct selection.

### ■ DTMF speed

USING INITIAL SET MODE

The rate at which DTMF memories send individual DTMF characters can be set to accommodate operating needs.



The display shows the fastest DTMF speed is selected.

- 1 Push [PWR] for 1 sec. to turn power OFF.
- 2 While pushing [SET•LOCK], push [PWR] for 1 sec. to turn power ON and enter initial set mode.
- 3 Push [SET•LOCK] or [S.MW•MW] several times until “DTD” appears as shown above.
- 4 Rotate [DIAL] to select the desired speed as shown in the table below.
- 5 Push [PWR] to exit initial set mode.  
cps=characters/sec

## ■ Pocket beep operation

This function uses subaudible tones for calling and can be used as a “common pager” to inform you that someone has called while you were away from the transceiver.

### ◇ Waiting for a call from a specific station

- ① Set the operating frequency.
- ② Push [SET•LOCK] to enter set mode.  
• Rotate [DIAL] to select “SET,” if necessary.
- ③ Push [SET•LOCK] or [S.MW•MW] several times until “CT” for tone squelch or “DT” for DTCS squelch appears.

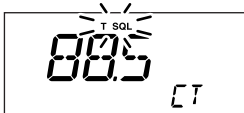

Tone squelch frequency setting



DTCS code setting

- ④ Rotate [DIAL] to select the desired tone squelch frequency.
- ⑤ When operating the pocket beep function with DTCS squelch, push [SET•LOCK] once then rotate [DIAL] to select the DTCS polarity.

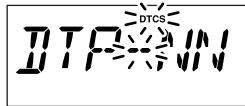

DTCS polarity setting

- ⑥ Push [TONE•T-SCAN] to exit set mode.

- ⑦ Push [TONE•T-SCAN] several times until “T SQL ((•))” or “((•)) DTCS” are displayed to turn ON the pocket beep with tone squelch or DTCS squelch, respectively.

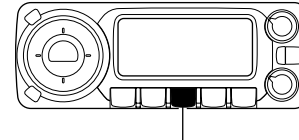

Push [TONE•T-SCAN] several times to select the pocket beep function with tone squelch or DTCS squelch.

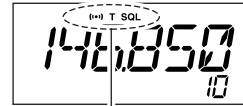

Appears when the pocket beep with tone squelch is activated.

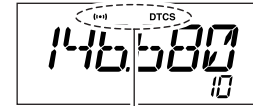

Appears when the pocket beep with DTCS squelch is activated.

- ⑧ When a signal with the matched tone is received, the transceiver emits beep tones and blinks “((•)).”
  - Beep tones sound for 30 sec. and “((•))” blinks. To stop the beeps and blinking manually, push any key. When the beep tones are not stopped manually, “((•))” continues blinking until [PTT] is pushed (see step ⑨).
- ⑨ Push [PTT] to answer.
  - “((•))” disappears and cancels the pocket beep function automatically.
- ⑩ Push [TONE•T-SCAN] several times until “T SQL” or “DTCS” disappears to cancel the tone squelch or DTCS squelch function.

# 10 POCKET BEEP AND TONE SQUELCH



- 1 Set the operating frequency.
- 2 Program the CTCSS tone frequency or DTCS code in set mode.
  - ➔ Push [SET B(D-OFF)] to enter set mode.
    - Push [▲] or [▼] to select “SET,” if necessary.
  - ➔ Push [SET B(D-OFF)] or [ENT C(T-OFF)] several times until “CT” for tone squelch or “DT” for DTCS squelch appears.
    - “T SQL” blinks when tone squelch (“CT”), or “DTCS” blinks when DTCS squelch (“DT”) is selected.
  - ➔ Push [▲]/[▼] to select the desired tone frequency or DTCS code.
  - ➔ Push [SET B(D-OFF)] to select “DTP” then push [▲]/[▼] to select the DTCS polarity.
  - ➔ Push [CLR A(MW)] to exit set mode.
- 3 Push [FUNC] then push [DUP+ 8(TSQL ((·)))] or [MID 5(DTCS ((·)))] to turn ON the pocket beep with tone squelch or DTCS squelch, respectively.
- 4 When a signal with the matched tone is received, the transceiver emits beep tones for 30 sec. and blinks “((·)).”
- 5 Push [PTT] to answer or push [CLR A(MW)] to stop the beeps and blinking.
  - “((·))” disappears and cancels the pocket beep function automatically.
- 6 To cancel the tone squelch or DTCS squelch function, push [FUNC] then [ENT C(T-OFF)].
  - “T SQL” or “DTCS” disappears

## ◆ Available tone frequency list

67.0	79.7	94.8	110.9	131.8	156.7	171.3	186.2	203.5	229.1
69.3	82.5	97.4	114.8	136.5	159.8	173.8	189.9	206.5	233.6
71.9	85.4	100.0	118.8	141.3	162.2	177.3	192.8	210.7	241.8
74.4	88.5	103.5	123.0	146.2	165.5	179.9	196.6	218.1	250.3
77.0	91.5	107.2	127.3	151.4	167.9	183.5	199.5	225.7	254.1

NOTE: The transceiver has 50 tone frequencies and consequently their spacing is narrow compared to units having 38 tones. Therefore, some tone frequencies may receive interference from adjacent tone frequencies.

To prevent interference from adjacent tone frequencies, using the frequencies as in the following table, is recommended.

### • Recommended tone frequencies

67.0	77.0	88.5	100.0	114.8	131.8	151.4	173.8	203.5	233.6
69.3	79.7	91.5	103.5	118.8	136.5	156.7	179.9	210.7	241.8
71.9	82.5	94.8	107.2	123.0	141.3	162.2	186.2	218.1	250.3
74.4	85.4	97.4	110.9	127.3	146.2	167.9	192.8	225.7	

## ◆ Calling a waiting station using pocket beep

A subaudible tone matched with the station’s CTCSS tone frequency or 3-digit DTCS code with polarity is necessary. Use the tone squelch on the next page or a subaudible tone encoder (pgs. 22, 23).

## ■ Tone/DTCS squelch operation

The tone or DTCS squelch opens only when receiving a signal with the same pre-programmed subaudible tone or DTCS code, respectively.

- ① Set the operating frequency.
- ② Program the CTCSS tone frequency or DTCS code in set mode.
  - See p. 52 for programming details.
- ③ Push [TONE•T-SCAN] several times until “T SQL” or “DTCS” appears in the function display.
- ④ When a signal with the matched tone is received, the squelch opens and the signal can be heard.
  - When the received signal includes an unmatched tone, the squelch does not open. However, the S/RF indicator shows the received signal strength.
  - To open the squelch manually, push [MONI•DTMF].
- ⑤ Operate the transceiver in the normal way (push [PTT] to transmit; release [PTT] to receive).
- ⑥ To cancel the tone squelch, push [TONE•T-SCAN] several times until “T SQL” or “DTCS” disappears.



- ① Set the operating frequency.
- ② Program the CTCSS tone frequency or DTCS code in set mode.
  - See p. 52 for programming details.
- ③ Push [FUNC] then [SIMP 9(TSQL)] or [HIGH 4(DTCS)] to turn the tone squelch or DTCS squelch ON.
- ④ When a signal with the matched tone is received, the squelch opens and the signal can be heard.
  - When the received signal includes an unmatched tone, the squelch does not open. However, the S/RF indicator shows the received signal strength.
  - To open the squelch manually, push [MONI 1(BANK)].
- ⑤ Operate the transceiver in the normal way (push [PTT] to transmit; release [PTT] to receive).
- ⑥ To cancel the tone squelch, push [FUNC] then [ENT C(T-OFF)].
  - “T SQL” or “DTCS” disappears.



## 10 POCKET BEEP AND TONE SQUELCH

### ■ Tone scan

By monitoring a signal that is being operated with pocket beep, tone or DTCS squelch function, you can determine the tone frequency or DTCS code necessary to open a squelch.

- ① Set the desired operating frequency or memory channel to be checked for a tone frequency or code.
- ② Push [TONE•T-SCAN] several times to select the tone type, tone squelch or DTCS, to be scanned.
  - Either “T SQL” or “DTCS” appears
- ③ Push [TONE•T-SCAN] for 1 sec. to start the tone scan.
  - To change the scanning direction, rotate [DIAL].

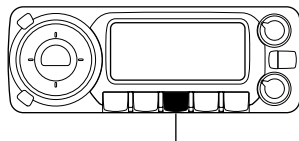

Push [TONE•T-SCAN] for 1 sec. to start tone scan.

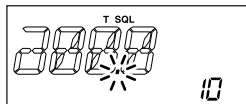

During CTCSS frequency scan

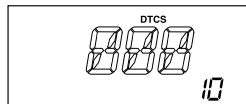

During DTCS code scan

- ④ When the CTCSS tone frequency or 3-digit DTCS code is matched, the squelch opens and the tone frequency is temporarily programmed into the selected condition such as memory or call channel.
  - The tone scan pauses when a CTCSS tone frequency or 3-digit DTCS code is detected.
  - The decoded CTCSS tone frequency or 3-digit DTCS code is used for the tone encoder or tone encoder/decoder depending on the selected tone condition or type in step ②.
    - “T SQL” : CTCSS tone encoder/decoder
    - “DTCS” : DTCS tone encoder/decoder
- ⑤ Push [TONE•T-SCAN] to stop the scan.



- ① Set the frequency or memory channel to be checked for a tone frequency.
- ② Selects the tone type to be scanned.
  - Push [FUNC] then push; [SIMP 9(TSQL)] for tone squelch; [HIGH 4(DTCS)] for DTCS squelch.
- ③ Push [FUNC] then [SCAN 2(T-SCAN)] to start the tone scan.
- ④ When the tone frequency is matched, the squelch opens and the tone frequency is programmed into the selected mode such as memory or call channel.
- ⑤ Push [CLR A(MW)] to stop the scan.

**NOTE:** The decoded tone frequency is programmed temporarily when a memory or call channel is selected. However, this will be cleared when the memory/call channel is re-selected.

## ■ Set mode

### • Set mode operation

- ① Push [SET•LOCK] to enter the set mode.
  - Rotate [DIAL] to select "SET," if necessary.
- ② Push [SET•LOCK] or [S.MW•MW] to select the desired item.
- ③ Rotate [DIAL] to select the condition or value.
- ④ Push [MONI•DTMF] to exit set mode.



- ① Push [SET B(D-OFF)] to enter set mode.
  - Push [▲] or [▼] to select "SET," if necessary.
- ② Push [SET B(D-OFF)] or [ENT C(T-OFF)] to select the desired item.
- ③ Push [▲] or [▼] to select the condition or value.
- ④ Push [CLR A(MW)] to exit set mode.

### • Set mode items

<p>• Display dimmer</p> <p><i>DIM-- 8</i></p> <p>↓ ↑</p> <p>• Bank link function<sup>1D</sup></p> <p><i>BKL --OF</i></p> <p>↓ ↑</p> <p>• Weather alert*</p> <p><i>ALT --OF</i></p> <p>↓ ↑</p> <p>• Program skip<sup>1D</sup></p> <p><i>PSC --ON</i></p>	<p>• Display color</p> <p><i>COL --AM</i></p> <p>→ : Push  SET LOCK (front panel); or  (microphone)</p> <p>→ : Push  S.MW MW (front panel); or  (microphone)</p> <p>• Mic lock function</p> <p><i>MLK --OF</i></p> <p>• Repeater tone<sup>□</sup> frequency</p> <p><i>885</i></p> <p>• Tone squelch<sup>□</sup> frequency</p> <p><i>885</i></p>	<p>• DTCS code</p> <p><i>023</i></p> <p>↓ ↑</p> <p>• DTCS polarity</p> <p><i>DTP --NN</i></p> <p>↓ ↑</p> <p>• Offset frequency</p> <p><i>0600</i></p>	<p>• Bank setting<sup>1D</sup></p> <p><i>BAK</i></p> <p>• Memory name<sup>1D</sup></p> <p><i>ANM --OF</i></p> <p>• Channel skip setting<sup>1D</sup></p> <p><i>CHS --OF</i></p> <p>• Scan resume timer</p> <p><i>SCT -- 15</i></p> <p>• Tuning step</p> <p><i>T5 -- 25</i></p>
---	---	---	--

\*Available for USA version only. □  
<sup>1D</sup>Appears when accessing set mode from VFO mode only. □  
<sup>1D</sup>Appears when accessing set mode from memory mode only. □

## 11 OTHER FUNCTIONS

### ◆ Display dimmer

Adjust to suit lighting conditions.

The levels 1 (dark) to 8 (bright: default) are available.

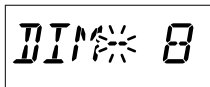

### ◆ Display color

The display color can be set to amber (default), yellow or green.

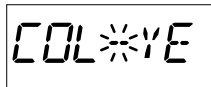

• Yellow setting

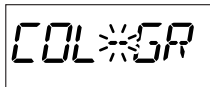

• Green setting

### ◆ Mic lock function

Sets the supplied HM-133's (optional for some versions) key lock function from ON and OFF (default).

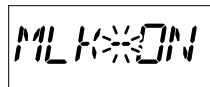
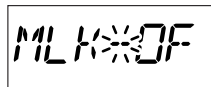

### ◆ Repeater tone

Sets subaudible tone frequency (encoder only) for repeater operation. Total of 50 tone frequencies (67.0–254.1 Hz) are available. (default: 88.5 Hz)



### ◆ Tone squelch tone

Sets subaudible tone frequency (both encoder and decoder) for tone squelch operation. Total of 50 tone frequencies (67.0–254.1 Hz) are available. (default: 88.5 Hz)



### • Available subaudible tone frequencies

67.0	79.7	94.8	110.9	131.8	156.7	171.3	186.2	203.5	229.1
69.3	82.5	97.4	114.8	136.5	159.8	173.8	189.9	206.5	233.6
71.9	85.4	100.0	118.8	141.3	162.2	177.3	192.8	210.7	241.8
74.4	88.5	103.5	123.0	146.2	165.5	179.9	196.6	218.1	250.3
77.0	91.5	107.2	127.3	151.4	167.9	183.5	199.5	225.7	254.1

◆ DTCS code

Sets DTCS code (both encoder and decoder) for DTCS squelch operation. Total of 104 codes are available. (default: 023)



◆ DTCS polarity

Sets DTCS polarities for transmission and reception from "NN," "NR," "RN" and "RR." (default: NN)



- Transmit □ normal
- Receive □: normal (default)



- Transmit □ normal
- Receive □: reverse

◆ Offset frequency

Sets the duplex offset frequency within 0 to 20 MHz range. During duplex (repeater) operation, transmit frequency shifts the set frequency. (default value may differ depending on operating frequency band and versions)



◆ Tuning step

Selects tuning step from 5, 10, 12.5, 15, 20, 25, 30, 50, 100 and 200 kHz for [DIAL] or [▲]/[▼] operation. (default value may differ depending on operating frequency band and versions)



## 11 OTHER FUNCTIONS

### ◇ Scan resume timer

Selects scan resume timer from SCT-15 (default), SCT-10, SCT-5 and SCP-2.

- SCT-15/10/5 : Scan pauses for 15/10/5 sec., then resumes.
- SCP-2 : Pause on a signal until signal disappears, then resumes 2 sec. after the signal disappears.

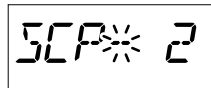
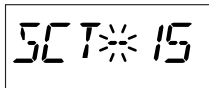

### ◇ Channel skip setting

Sets channel skip setting from ON and OFF for memory skip scan operation.

This item appears when set mode is accessed from memory mode only.



- Default setting



- "SKIP" or "P SKIP" appears when set to "ON." □

### ◇ Memory name setting

Sets memory name setting from ON (appear) and OFF (not appear; default) for memory name appearance.

This item appears when set mode is accessed from memory mode only.



### ◇ Memory bank setting

Sets the desired memory bank (A to J and OFF) to assign the regular memory channels.

This item appears when set mode is accessed from memory mode only.

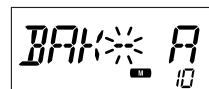
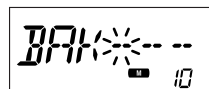

### ◇ Program scan skip setting

Sets the program scan skip setting from ON and OFF for VFO scan operation, such as programmed scan.

This item appears when set mode is accessed from VFO mode only.



### ◇ Weather alert function

U.S.A. version only

Turns weather alert function ON and OFF.

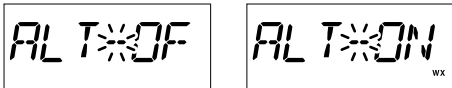

### ◇ Memory bank link function

Sets the memory bank link function ON and OFF (default). The link function provides continuous banks scan, that scans all contents in the selected banks during bank scan.

This item appears when set mode is accessed from memory mode only.

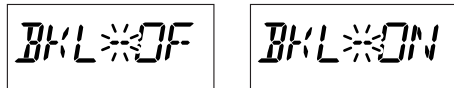

#### • Bank link setting

- ① Rotate [DIAL] to select the memory bank link function ON.
- ② Push [SET•LOCK] or [S.MW•MW] to select the desired bank to be linked.
  - BLA: Bank A, BLB: Bank B, BLC: Bank C, BLD: Bank D, BLE: Bank E, BLF: Bank F, BLG: Bank G, BLH: Bank H, BLI: Bank I, BLJ: Bank J

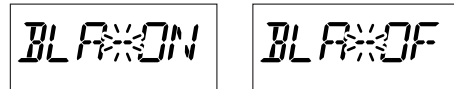

- ③ Rotate [DIAL] to select "ON" to linking the bank.
- ④ Repeat steps ② and ③ to set the link condition.

# 11 OTHER FUNCTIONS

## ■ Initial set mode







AT POWER ON

The initial set mode is accessed at power ON and allows you to set seldom-changed settings. In this way, you can “customize” transceiver operations to suit your preference and operating style.

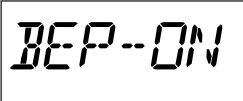
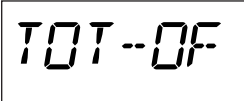
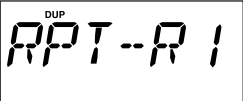
### • Initial set mode items

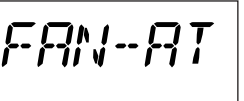
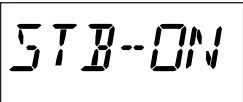
### ◇ Entering initial set mode

- ① While pushing [SET•LOCK], push [PWR] for 1 sec. to enter initial set mode.
- ② Push [SET•LOCK] or [S.MW•MW] to select the desired item.
- ③ Rotate [DIAL] to select the condition or value.
- ④ Push [PWR] momentarily to exit initial set mode.

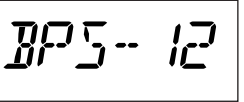
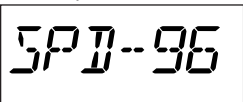
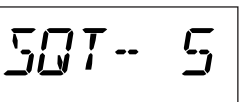
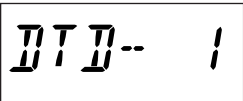
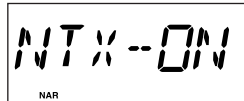
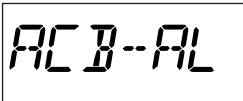
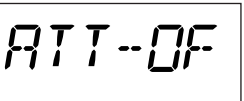
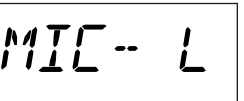
<p>• Key-touch beep</p> 	<p>• Time-out timer</p> 	<p>• Auto repeater*</p> 	<p>• Auto power off</p> 	<p>• Cooling fan</p> 
<p>• Stanby beep</p> 	<p>→ : Push  (front panel); or  (microphone)</p> <p>→ : Push  (front panel); or  (microphone)</p> <p>*Available in the USA version only.</p>		<p>• Data speed for FM mode</p> 	
<p>• Data speed for DV mode</p> 				<p>• Squelch delay</p> 
<p>• DTMF speed</p> 	<p>• Narrow TX</p> 	<p>• Active band</p> 	<p>• Squelch attenuator</p> 	<p>• Microphone sensitivity</p> 

### ◆ Key-touch beep

The key-touch beep can be turned OFF for silent operation.

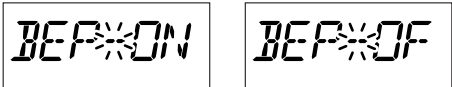

### ◆ Time-out timer

To prevent accidental prolonged transmission, etc., the transceiver has a time-out timer. This function cuts a transmission OFF after 1–30 min. of continuous transmission. This timer can be cancelled.

- TOT:OFF : The time-out timer is turned OFF.
- TOT-3/5/15/30 : The transmission is cut OFF after the set period elapses.

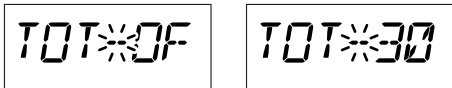

### ◆ Auto repeater

U.S.A. version only

The auto repeater function automatically turns ON or OFF the duplex operation with a specified shift direction and tone encoder, when the operating frequency falls within or outside of 145.200–145.495, 146.610–146.995, 147.000–147.395, 442.000–444.995, and 447.000–449.995 MHz range. The offset and repeater tone frequencies are not changed by the auto repeater function, reset these frequencies, if necessary.

- OF : The auto repeater function is turned OFF.
- R1 : Activates for duplex only.
- R2 : Activates for duplex and tone.

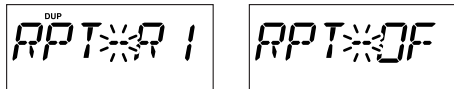

### ◆ Auto power OFF

The transceiver can be set to automatically turn OFF after a specified period with a beep when no key operations are performed.

30 min., 1 hour, 2 hours and OFF can be specified. The specified period is retained even when the transceiver is turned OFF by the auto power OFF function. To cancel the function, select "OF" in this set mode.

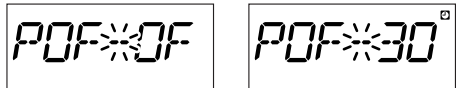



## 11 OTHER FUNCTIONS

### ◇ Cooling fan control

Selects the cooling fan control condition from Auto and ON.

- Auto (AT) : The fan rotates during transmit and for 2 min. after transmission, or when the internal temperature of the transceiver exceeds the pre-set value until the temperature drops.
- ON (ON) : The fan continuously rotates.

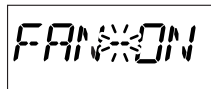
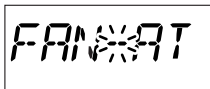

### ◇ Data transmission speed

Selects the data transmission speed for packet operation from 1200 bps and 9600 bps.

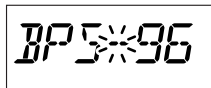
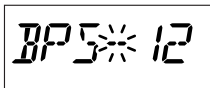

### ◇ Squelch delay

Selects squelch delay from short and long to prevent repeated opening and closing of the squelch during reception of the same signal.

- S : Short squelch delay.
- L : Long squelch delay.

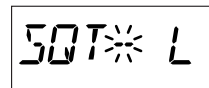
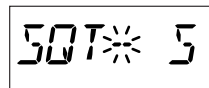

### ◇ Microphone sensitivity

Selects the microphone sensitivity from high (H) and low (L) to suits your preference.



### ◇ Squelch attenuator

Turns the squelch attenuator function ON and OFF.

- ON : The squelch attenuator activates when [SQL] control is set between 12 o'clock and fully clockwise position.
- OF : The squelch attenuator does not function.

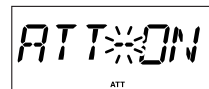

### ◇ Active band

Selects the frequency selecting condition via [DIAL] or [▲]/[▼] on the microphone from all (AL) and single (SI).

- All (AL) : The operating frequency can be selected continuously.
- Single (SI) : The operating frequency can be selected within the current band. Pushing [BAND] for 1 sec. then tuning dial rotation is necessary for frequency band selection.

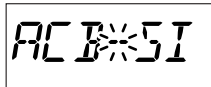
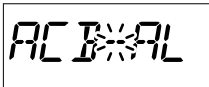

### ◇ Narrow TX function

Select the narrow TX function ON and OFF.

- ON : Enables the FM-narrow mode transmission. The deviation (modulation level) becomes half from the regular FM transmission can be performed.
- OFF : Inhibits the FM-narrow mode transmission. The regular FM deviation transmission is performed ("NAR" indication disappears while transmission) even when FM-narrow is selected.



### ◇ DTMF speed

The rate at which DTMF memories send individual DTMF characters can be set to accommodate operating needs.

- 1 : 100 msec. interval; 5.0 cps speed
- 2 : 200 msec. interval; 2.5 cps speed
- 3 : 300 msec. interval; 1.6 cps speed
- 5 : 500 msec. interval; 1.0 cps speed

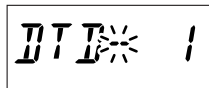

### ◇ Data Speed

Select the communication speed between the transceiver and PC from 4800 baud or 9600 baud. (default: 9600)

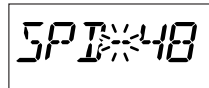
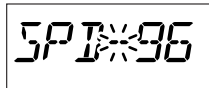

### ◇ Standby Beep

Turns the beep emission capability when the communicating station finishes transmitting or the receive signal disappears. while in the digital mode operation. (default: OFF)

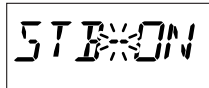

## 11 OTHER FUNCTIONS

### ■ AM/FM narrow mode

The ID-800H has AM mode reception and FM narrow mode is available. Typically, AM mode is used for the air band (118–135.995 MHz).

- ① Select the desired frequency band in VFO mode, or the desired memory channel.
- ② Push [BAND] for 1 sec. to select AM/FM narrow mode as desired.
  - “NAR” (FM narrow), “AM” and “NAR AM” appears in sequence.
  - No indication stands for FM mode.

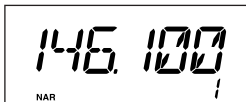

- When FM narrow mode is selected



- When AM mode is selected

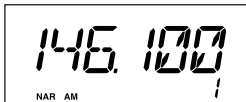

- When AM narrow mode is selected



- ① Push [BAND] or [MR/CALL] to select the desired frequency band or memory channel.
- ② Push [BAND] for 1 sec. to select AM/FM narrow mode as desired.
  - “NAR”, “AM” and “NAR AM” appears in sequence.
  - No indication stands for FM mode.

## ■ Weather channel operation

(USA version only)

### ◆ Weather channel selection

- ① Push [M/CALL•PRIO] several times to select weather channel group.

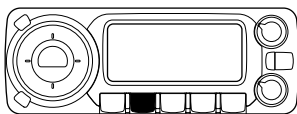

[M/CALL•PRIO]

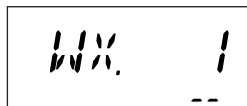

Weather channel group indication

- ② Rotate [DIAL] to select the desired weather channel.
- ③ Push [M/CALL•PRIO] to select memory mode, or push [V/MHz•SCAN] to select VFO mode.

### ◆ Weather alert function

NOAA broadcast stations transmit weather alert tones before important weather announcements. When the weather alert function is turned ON, the selected weather channel is monitored each 5 sec. for the announcement. When the alert signal is detected, the "AL.T" and the WX channel are displayed alternately and sounds a beep tone until the transceiver is operated. The previously selected (used) weather channel is checked periodically during standby or while scanning.

- ① Select the desired weather channel.
- ② Turn the weather alert function ON in set mode.
  - ➔ Push [SET•LOCK] to enter set mode.
  - ➔ Push [SET•LOCK] or [S.MW•MW] to select the weather alert item, then rotate [DIAL] to set ON.
  - ➔ Push [MONI•DTMF] to exit set mode.
- ③ Sets the desired stand-by condition.
  - Selects VFO, memory or call channel.
  - Scan or priority watch operation can also be selected.
- ④ When the alert is detected, a beep sounds and the following indication will be displayed.

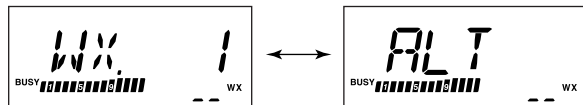

Shows above indications alternately.

- ⑤ Turn the weather alert function OFF in set mode.
- NOTE:** While receiving a signal (on a frequency other than the weather alert ON frequency), the receiving signal or audio will be interrupted momentarily every 5 sec. (approx.) in case the alert function is turned ON. This symptom is caused by the WX alert function. To cancel these symptoms, set the weather alert item OFF in set mode.

## 11 OTHER FUNCTIONS

### ■ Microphone keys

The supplied HM-133's (optional for some versions) [F-1] and [F-2] keys memorize the transceiver conditions.

The [UP]/[DN] keys of the standard or an optional microphone (other than the HM-133) can be assigned functions like the function keys on the transceiver's front panel.

#### ◇ [UP]/[DN] keys on a microphones

(other than HM-133)

AT POWER ON

The following functions are assigned to [UP]/[DN] keys on the other microphones (HM-118N/TAN, etc.) when first applying power.

##### • Default setting

[UP] : channel up; push and hold to start scan, push again to stop scan.

[DN] : channel down; push and hold to start scan, push again to stop scan.

##### ➤ **Assigning a function**

- ① Turn the power OFF.
- ② While pushing the desired switch on the transceiver and one of either [UP]/[DN] keys on the microphone, turn the power ON.
  - The function is programmed into the key.

##### ➤ **Clearing an assignment**

- ① Turn the power OFF.
- ② While pushing the desired [UP] or [DN] key on the microphone, turn the power ON.

#### ◇ [F-1]/[F-2] keys on HM-133

The following conditions can be memorized into [F-1] and [F-2] keys, independently.

- Operating frequency
- Repeater setting (offset direction and frequency, tone ON/OFF and frequency)
- Tone/DTCS squelch (ON/OFF, frequency/code and polarity)
- Transmit output power selection
- Tuning step
- Operating mode selection (FM/AM)



##### ➤ **Programming the band condition**

- Push [F-1]/[F-2] for 1 sec.
  - 3 beeps sound.

##### ➤ **Recalling the band condition**

- Push [F-1]/[F-2] momentarily.

##### ➤ **Initializing the band condition**

- Push [FUNC] then push [F-1]/[F-2].  
The following conditions are initialized.
- Operating band: 145 MHz band
  - Repeater setting (tone frequency: 88.5 Hz, offset frequency: 600 kHz)
  - Tone/DTCS squelch (ON/OFF: OFF, tone frequency: 88.5 Hz, DTCS code: 023 and polarity: NN)
  - Transmit output power selection: HIGH
  - Tuning step: 5 kHz
  - Call channel: 1 CH, memory channel: 1CH
  - Operating mode selection: FM

## ■ Partial reset

AT POWER ON

If you want to initialize the operating conditions (VFO frequency, VFO settings, set mode contents) without clearing the memory contents.

- ➔ While pushing [V/MHz•SCAN] and [SET•LOCK], push [PWR] for 1 sec. to partially reset.

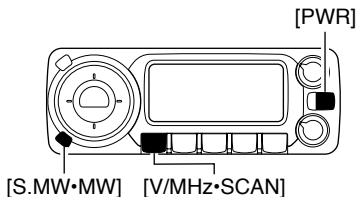

## ■ All reset

AT POWER ON

The function display may occasionally display erroneous information (e.g. when first applying power). This may be caused externally by static electricity or by other factors.

If this problem occurs, turn power OFF. After waiting a few seconds, turn power ON again. If the problem persists, perform the following procedure.

- Partial resetting is also available. See left for details.

### /// IMPORTANT!:

Resetting the transceiver **CLEARs** all memory information and initializes all values in the transceiver.

- ➔ While pushing [S.MW•MW] and [SET•LOCK], push [PWR] for 1 sec. to reset the CPU.

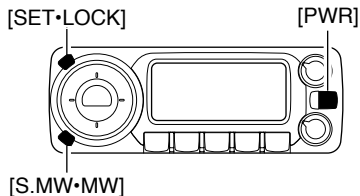

## 11 OTHER FUNCTIONS

### ■ Data cloning

AT POWER ON

Cloning allows you to quickly and easily transfer the programmed contents from one transceiver to another; or data from a personal computer to a transceiver using the optional CS-D800 CLONING SOFTWARE.

#### ◇ Cloning between transceivers

① Connect the OPC-474 cloning cable to [SP] jack of the master and sub-transceivers.

- The master transceiver is used to send data to the sub-transceiver.

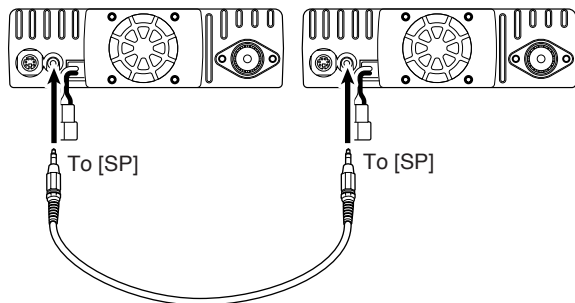

② While pushing [M/CALL•PRIO], turn power ON to enter cloning mode (master transceiver only— power on only for sub-transceiver).

- “CLONE” appears and the transceivers enter the clone standby condition.

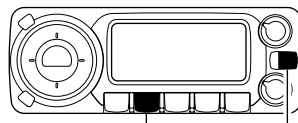

[M/CALL•PRIO] [PWR]

While pushing [M/CALL•PRIO], turn power ON.

③ Push [SET•LOCK] on the master transceiver.

- “CL OUT” appears in the master transceiver’s display and the S/R/F indicators show that data is being transferred to the sub-transceiver.
- “CL IN” appears automatically in the sub-transceiver’s display and the S/R/F indicators show that data is being received from the master transceiver.

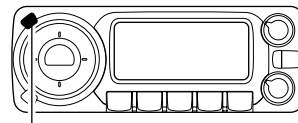

Pushing [SET•LOCK] start cloning.

④ When cloning is finished, turn power OFF, then ON to exit cloning mode.

### ◇ Cloning using a personal computer

Data can be cloned to and from a personal computer (Microsoft® Windows® 98/2000/Me/XP) using the optional CS-208 CLONING SOFTWARE and the optional cloning cable OPC-478U (USB type) or OPC-478 (RS-232C type). Consult the CS-208 CLONING SOFTWARE HELP file for details.

### ◇ Cloning error

NOTE: **DO NOT** push any key on the sub-transceiver during cloning. This will cause a cloning error.

When the display as below appears, a cloning error has occurred.

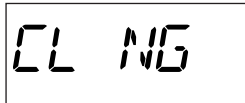

In such a case, both transceivers automatically return to the clone standby condition and cloning must be repeated.



## 11 OTHER FUNCTIONS

### ■ Packet operation

#### ◇ Data speed

For packet operation, the transceiver can be set to one of two data speeds: 1200 bps or 9600 bps.

- ① While pushing [SET•LOCK], push [PWR] for 1 sec. to enter initial set mode.
- ② Push [SET•LOCK] or [S.MW•MW] to select the 'BPS' item.
- ③ Rotate [DIAL] to select the desired data speed.

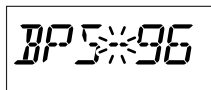
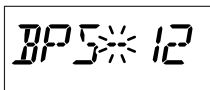

- ④ Push [PWR] to exit initial set mode.

#### ▨ For 1200 bps operation—

- Disconnect the microphone plug from the microphone connector during data transmission, otherwise the data signal and voice signal are simultaneously transmitted.

#### ▨ For 9600 bps operation—

- When the transceiver is set for 9600 bps data transmission in set mode, the microphone signal is automatically cut. Therefore, it is not necessary to disconnect the microphone plug from the connector in this case.
- When pushing [PTT] during data transmission, data transmission is interrupted and voice signals have priority.

#### ◇ 1200 bps packet operation

- ① Connect the transceiver and a TNC as illustrated below.

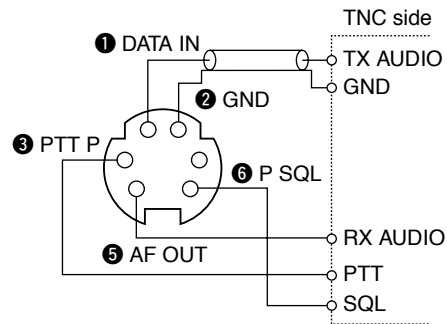

- ② Set the TNC for transmit.
- ③ Set transmit delay on the TNC.
- ④ Adjust the TNC frequency deviation if necessary.

#### • When using a deviation meter:

Adjust the output of the TNC so that frequency deviation is in the range  $\pm 3$  to  $\pm 4$  kHz.

#### • When NOT using a deviation meter:

A receiver or transceiver is needed to monitor the transmission—compare the received audio output level when receiving a TNC modulated signal with high level voice signals using the microphone. Then adjust the TNC modulated signal to a lower level than the voice modulated signal.

- Read the instructions supplied with your TNC carefully before attempting packet operation with the transceiver.
- Pin ⑤ AF OUT is for 1200 bps operation only. This pin cannot be used for 9600 bps operation.
- Over modulation may degrade signal quality. If you find that many transmissions are failing, re-adjust the modulation level.

## 11 OTHER FUNCTIONS

### ◇ 9600 bps high speed packet operation

The transceiver supports 2 modes of 9600 bps packet operation: G3RUH and GMSK.

① Connect the transceiver and a TNC as illustrated below.

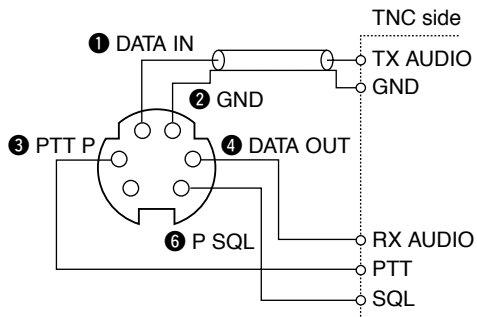

② G3RUH mode can handle 16 kinds of modulated wave forms in order to maintain a communication link.

③ Set transmit delay on the TNC.

④ Adjust the TNC frequency deviation if necessary (see page at right).

- When using the PTT P terminal for packet operation, no voice signals are transmitted from the microphone.
- When pushing [PTT] during data transmission, data transmission is interrupted and the voice signal takes priority.
- Read the instructions supplied with your TNC carefully before attempting packet operation with the transceiver.
- Pin ④ DATA OUT is for 9600 bps operation only. This pin cannot be used for 1200 bps operation.

## ◇ Adjusting the transmit signal output from the TNC

When setting data transmission speed to 9600 bps, the data signal coming from the TNC is applied exclusively to the internal limiter circuitry to automatically maintain band width.

**NEVER** apply data levels from the TNC of over the acceptable level below, otherwise the transceiver will not be able to maintain the band width and may possibly interfere with other stations.

### 1. When using a level meter or synchroscope, adjust the TX audio output level (DATA IN level) from the TNC as follows.

- 2 Vp-p (1 Vrms) : recommended level
- 1 Vp-p–3 Vp-p (0.5–1.5 Vrms) : acceptable level

### 2. When NOT using a measuring device.

- ① Connect the transceiver to a TNC.
- ② Enter a test mode (“CAL,” etc.) on the TNC, then transmit some test data.
- ③ *When the transceiver fails to transmit the test data or transmits sporadically (TX indicator doesn’t appear or flashes):*
  - Decrease the TNC output level until the transmit indicator lights continuously.*When transmission is not successful even though the TX indicator lights continuously:*
  - Increase the TNC output level.

# 12 DIGITAL MODE OPERATION

## ■ Digital mode operation

The ID-800H can be operated for digital voice mode and slow data operation for both transmit and receive. Also available for connecting GPS receiver (compatible with an RS-232C output/NMEA format/4800 bps) and transmit/receive position data.

## ■ Call sign programming

4 kind of call sign memories are available for your own call sign "MyCALL," other station call sign "UrCALL" and nearest repeater call sign "RPT1 C" and another zone's repeater call sign "RPT2 C." Each call sign memory can be stored up to 6 call signs, and each call sign programmed up to 8 characters.

### ◆ Your call sign programming

Your call sign must be programmed for both Digital voice and slow data communications (including GPS transmission).

- ① Push **[SET•LOCK]** to enter call sign set mode.
  - Rotate **[DIAL]** to select "CALLS," if "SET" or "MESSAG" is displayed.
- ② Push **[SET•LOCK]** or **[S.MW•MW]** several times to select "MyCALL," then push **[BAND]**.

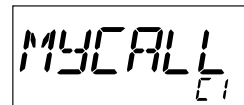

- ③ Rotate **[DIAL]** to select the desired call sign channel.

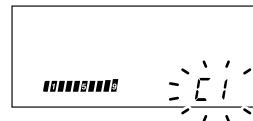

- ③ Push **[BAND]** to set into call sign programming condition.
  - The 1st digit blinks and channel indication stops blinking.
- ④ Rotate **[DIAL]** to set the desired character or code.
  - Push **[SET•LOCK]** or **[S.MW•MW]** to move the cursor to right or left, respectively.
  - Push **[V/MHz]** to cancel and exit the call sign programming.
- ⑤ Push **[SET•LOCK]** to select 2nd digit, then rotate **[DIAL]** to set the desired character or code.
  - 2nd digit blinks (1st digit stop blinking).
  - Repeat this step for programming your call sign.

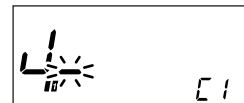

- ⑥ Push **[BAND]** twice to fix the call sign.
- ⑦ Rotate **[DIAL]** to select an another channel from "C1" to "C6."
- ⑧ Repeat steps ② to ⑥ to program your call sign channels.

### ◆ Station/Repeater1/2 call sign programming

Station call sign must be programmed for the specified station call as well as repeater operation in both Digital voice and slow data communications.

- ① Push **[SET•LOCK]** to enter call sign set mode.
  - Rotate **[DIAL]** to select “CALLS,” if “SET” or “MESSAG” is displayed.
- ② Push **[SET•LOCK]** or **[S.MW•MW]** several times to select the call sign item, then push **[BAND]**.
  - “UrCALL” appears for station call sign.
  - “RPT1 C” or “RPT2 C” appears for repeater call sign.



- ③ Rotate **[DIAL]** to select the desired call sign channel.

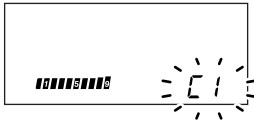

- ③ Push **[BAND]** to set into call sign programming condition.
  - The 1st digit blinks and channel indication stops blinking.
- ④ Rotate **[DIAL]** to set the desired character or code.
  - Push **[SET•LOCK]** or **[S.MW•MW]** to move the cursor to right or left, respectively.
  - Push **[V/MHz]** to cancel and exit the call sign programming.
- ⑤ Push **[SET•LOCK]** to select 2nd digit, then rotate **[DIAL]** to set the desired character or code.
  - 2nd digit blinks (1st digit stop blinking).

- Repeat this step for programming station/repeater call sign.

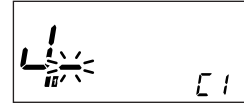

- ⑥ Push **[BAND]** twice to fix the call sign.
- ⑦ Rotate **[DIAL]** to select an another channel from “C1” to “C6.”
- ⑧ Repeat steps ② to ⑥ to program another station/repeater call sign channels.

#### ✓ For your information:

Repeater call sign can be programmed gateway connection capabilities at step ④ for connecting to the other Area or Zone.

- “G” appears or disappears at the 8th digit when each pushing **[M/CALL]**.



1

2

3

4

5

6

7

8

9

10

11

12

13

14

15

16

## 12 DIGITAL MODE OPERATION

### ■ Digital voice mode operation

- ① Set the desired frequency in VFO mode. (pgs. 11, 12)
  - Select output power, if desired. (p.17)
- ② Push **[BAND MODE]** for 1 sec. to enter the mode selection condition.
- ③ Rotate **[DIAL]** to select “DV,” then push **[BAND MODE]** to set the digital mode.
  - “DV” appears.

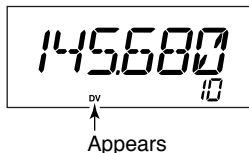

- ④ Push **[SET•LOCK]** to enter the call sign set mode.
  - Rotate **[DIAL]** to select “CALLS,” if “SET” or “MESSAG” is displayed.
- ⑤ Push **[SET•LOCK]** or **[S.MW•MW]** several times until “My CALL” apperes.
- ⑥ Rotate **[DIAL]** to select the desired your call sign channel, if you have programmed several call signs.

### ◇ When sending a CQ

- ⑦ Select “CQ” as the call sign.
  - Push **[SET• LOCK]** to select the call sign select mode.
  - Rotate **[DIAL]** to select “CALLS,” if “SET” or “MESSAG” is displayed.
  - Push **[SET•LOCK]** or **[S.MW•MW]** several times until “Ur-CALL” appears, then push **[BAND]**.
  - Rotate **[DIAL]** to select the desired channel then push **[BAND]**.
  - Push **[V/MHz]** to edit “CQCQCQ.”



- Push any key below the display to exit call sign set mode.

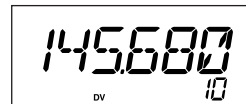

- ⑧ Push and hold **[PTT]** to transmit and speak into the microphone at normal voice level.
  - Transmit indicator appears and the RF meter shows the output power.
- ⑨ Release **[PTT]** to return to receive.
  - The other station call sign will be received.
  - Received call signs can be stored into the received call record automatically. See page 79 for details.

## ◆ When calling the desired station

- ⑦ Select the desired call sign.
- Push **[SET• LOCK]** to select the call sign select mode.
    - Rotate **[DIAL]** to select “CALLS;” if “SET” or “MESSAG” is displayed.
  - Push **[SET•LOCK]** or **[S.MW•MW]** several times until “Ur-CALL” appears, then push **[BAND]**.
  - Rotate **[DIAL]** to select the desired call sign (pre-programmed), or set the desired call sign. (see p. 76)



- Push any key below the display to exit call sign set mode.

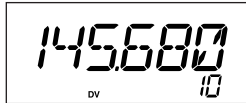

- ⑧ Push and hold **[PTT]** to transmit and speak into the microphone at normal voice level.
- Transmit indicator appears and the RF meter shows the output power.
- ⑨ Release **[PTT]** to return to receive.
- The other station call sign will be received.
  - Received call signs can be stored into the received call record automatically. See page 79 for details.

**NOTE:** The digital mode operation is vastly different than FM mode. One of the differences is in the digital mode the squelch does not function as FM mode, changing the squelch setting will not open to hear the hiss of “White Noise,” only activate for digital squelch function as CSQL (Digital code squelch) or DSQL (Call sign squelch).

1

2

3

4

5

6

7

8

9

10

11

12

13

14

15

16



## 12 DIGITAL MODE OPERATION

### ■ When receiving a Digital call

When an individual station call is received, the calling station call sign can be stored into the received call record.

The record is cleared once turning power OFF.

#### ◆ Received call record

- ① Push **[SET•LOCK]** to enter call sign set mode.
  - Rotate [DIAL] to select “CALLS,” if “SET” or “MESSAG” is displayed.
- ② Push **[SET•LOCK]** or **[S.MW•MW]** several times to select received call indication, then push **[BAND]**.
  - “RXCALL,” “RXRPT1,” and “RXRPT2” are available for the received station call sign, repeater 1/2 call signs, respectively.

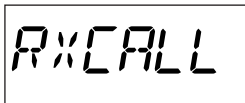

RXCALL

- ② To confirm the received call, push **[BAND]** to enter the received call sign indication mode.

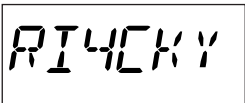

RT4CKY

### ■ Break-in communication

The break-in function allows you to break into another station's communications in both Digital voice and slow data operation.

- ① While receiving another station's communication, push **[SET•LOCK]** to enter call sign set mode.
  - Rotate [DIAL] to select “CALLS,” if “SET” or “MESSAG” is displayed.
- ② Push **[SET•LOCK]** or **[S.MW•MW]** several times to select received call indication, then set the either station/repeater call sign into “MyCALL,” “UrCALL,” “RPT1 C” and “RPT2 C.”
- ③ Push **[TONE•T-SCAN]** for 1 sec. to turn the break-in setting ON.
  - “BK” appears.

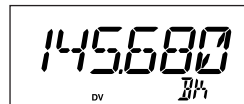

145.680  
DV

- ④ When both stations are in standby, transmit to send a break-in call.
  - Programmed call sign station receives the break-in call as well as your call sign.
- ⑤ Wait for the reply call from the station who receive the break-in call.
- ⑥ After receive the reply call, communicate normal way.
- ⑦ To cancel the break-in, push **[TONE•T-SCAN]** for 1 sec. to turn OFF.

## ■ EMR communication

The EMR communication mode is available for Digital modes operation. In the EMR call, no call sign setting is necessary.

- ① Set the desired frequency then push and hold **[MONI•DTMF]** until 4 beep sound to turn the EMR setting ON.
  - “EM” appears.

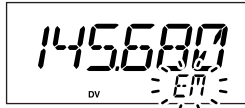

- ② Operate the transceiver normal way.
- ③ To cancel the EMR communication mode, push **[MONI•DTMF]** for 1 sec. to turn OFF.

## ■ Digital code/Call sign squelch operation

The digital code (CSQL) or call sign (DSQL) squelch opens only when receiving a voice signal with the same pre-programmed digital code or call sign, respectively. The digital code or call sign squelch does not function while in a slow data communication.

- ① Set the operating frequency.
- ② Program the digital code or call sign in setting mode.
  - See p. 69, “Digital code setting” or pgs. 59, 60 “Call sign programming.”
- ③ Push **[TONE•T-SCAN]** several times until “CSQL” or “DSQL” appears in the function display.
  - “CSQL” for digital code squelch; “DSQL” for call sign squelch operation.
- ④ When a signal with the matched digital code/call sign is received, the squelch opens and the signal can be heard.
  - When the received signal includes an unmatched digital code/call sign, the squelch does not open. However, the S/RF indicator shows the received signal strength.
  - To open the squelch manually, push **[MONI•DTMF]** momentarily.
- ⑤ Operate the transceiver in the normal way (push **[PTT]** to transmit; release **[PTT]** to receive).
- ⑥ To cancel the digital code/call sign squelch, push **[TONE•T-SCAN]** several times until “CSQL” or “DSQL” disappears.

### ✓ While scanning in digital mode:

- The call sign squelch function deactivate, then after cancelling the scan it will activate again.
- Scan stops near channel in a 5 kHz tuning steps, and then no sound comes out.

1

2

3

4

5

6

7

8

9

10

11

12

13

14

15

16

## 12 DIGITAL MODE OPERATION

### ■ Slow data communication

In addition to the digital voice communication, a slow data communication is available (Refer p. 5 about the transceiver-PC connection details).

- ① While pushing [SET•LOCK], push [PWR] for 1 sec. to enter initial set mode. (see p. 61)
- ② Push [SET•LOCK] or [S.MW•MW] several times to select the data communication speed setting. (see p.64)
  - “SPD” appears.
  - Select suitable data speed for your PC or application.

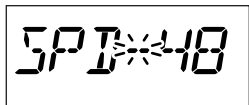
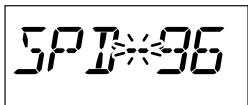

- ③ Set the desired frequency.
- ④ Set another settings, such as repeater call, digital code squelch, transmit output power.
- ⑤ Push [SET•LOCK] to enter set mode.
  - Rotate [DIAL] to select “SET,” if “CALLS” or “MESSAG” is displayed.
- ⑥ Push [SET•LOCK] or [S.MW•MW] several times to select the automatic data transmission setting. (see p.82)
  - “DVT” appears.
  - Skip this setting, if you want to transmit manually.

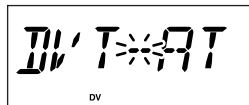
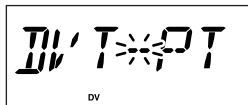

- ⑦ Start up the slow data communication application.
- ⑧ Set the application as follows.
  - Port : The same COM port number as ID-800H's
  - Baud rate : 4800 bps or 9600 bps (same as step ②)
  - Data : 8 bit
  - Parity : None
  - Stop : 1 bit
  - Flow control : Xon/Xoff
- ⑨ Transceiver automatically transmits or receive the data when you sending data to transceiver. Or push and hold [PTT] to transmit, release to receive the data manually.
  - Refer to the instruction of the application that how to send or receive data.

## ■ Other setting items

- ① During digital mode operation, push **[SET•LOCK]** to enter set mode.
  - Rotate **[DIAL]** to select “SET,” if “CALLS” or “MESSAG” is displayed.
- ② Push **[SET•LOCK]** or **[S.MW•MW]** to select the desired item.
- ③ Rotate **[DIAL]** to select the desired value or condition.

**BANK/OPTION**



- ① During digital mode operation, push **[SET B (D-OFF)]** to enter set mode, then push **[▲]** or **[▼]** to select “SET” if necessary.
- ② Push **[SET B(D-OFF)]** or **[ENT C (T-OFF)]** several times to select the desired item.
- ③ Push **[▲]** or **[▼]** to select the desired value or condition.

### ◇ Auto Reply

During Digital mode operation, auto reply function is available. This function replies to an individual station call even you are away from the transceiver. (default: OFF)

After the manual transmission (pushing **[PTT]**), the Auto Reply setting is return to OFF automatically.

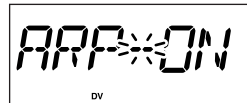
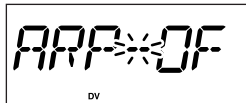

### ◇ Digital Code

Sets the desired digital code for digital code squelch operation. Total of 100 codes (00–99) are available. (default: 00)

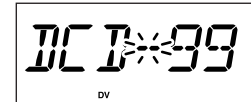
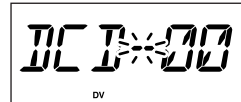

### ◇ Auto data Transmission

During slow data operation, auto data transmission function is available. This function transmits when data are input from PC via the **[DATA]** jack. (default: PTT)

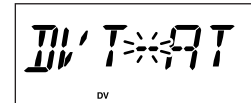
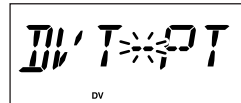

1

2

3

4

5

6

7

8

9

10

11

12

13

14

15

16

## 12 DIGITAL MODE OPERATION

### ◇ Auto RxCall Write

When an individual station call is received, the calling station call sign can be stored automatically. The stored call sign can be re-called when selecting a station call sign.

(default: OFF)



### ◇ Auto Rx RepeaterCall Write

When an individual station call via the repeater is received, the repeater call sign can be stored automatically. The stored repeater's call sign can be re-called when selecting a repeater call sign.

(default: OFF)

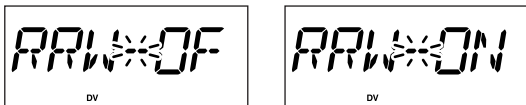

### ◇ Auto RxCall Display

When an individual station call is received, the calling station call sign can be indicated automatically.

(default: ON)

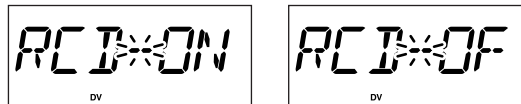

### ◇ Auto MyCALL Display

Sets auto MyCALL display function ON and OFF. When this setting is set to ON, the transceiver automatically indicates your programmed call sign at turning power ON or digital mode transmission.

(default: OFF)

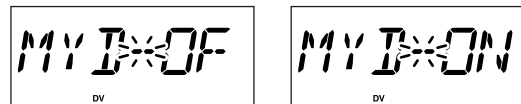

### ◆ Digital Monitor

Sets the desired monitoring mode during digital mode operation from “DI(Digital)” and “AN(Analog).” (default: DI)  
 Select “ANALOG” when using FM mode for monitoring.

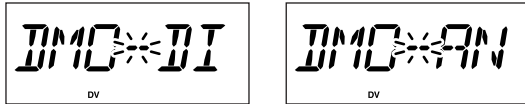

### ◆ Message Transmission

Select the Message transmission function ON and OFF.  
 When ON is selected, transceiver transmits a text message (pre-programmed). (default: OFF)

- ① Push **[SET•LOCK]** to enter message set mode.
  - Rotate [DIAL] to select “MESSAG,” if “CALLS” or “SET” is displayed.
- ② Push **[SET•LOCK]** or **[S.MW•MW]** several times to select the message transmission setting.
  - “TXM” appears.

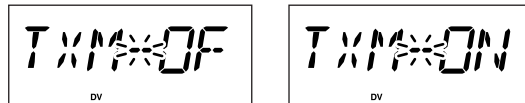

### ◆ TX message

TX messages are available up to 6 channels and each channel can be programmed up to 20 characters message. Available characters are **0** to **9**, **A** to **Z** (capital letters only), some symbols and space. (shown below table)

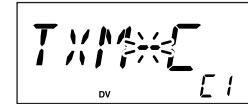

(space)	! (!)	"	# (#)	\$ (\$)	% (%)	& (&)	' (')	( ( (	) ) )	* (*)
+ (+)	, (,)	-- (-)	\ (.)	/ (/)	0 (0)	1 (1)	2 (2)	3 (3)	4 (4)	5 (5)
6 (6)	7 (7)	8 (8)	9 (9)	: (:)	: (:) (:	< (<)	= (=)	> (>)	? (?)	@ (@)
A (A)	B (B)	C (C)	D (D)	E (E)	F (F)	G (G)	H (H)	I (I)	J (J)	K (K)
L (L)	M (M)	N (N)	O (O)	P (P)	Q (Q)	R (R)	S (S)	T (T)	U (U)	V (V)
W (W)	X (X)	Y (Y)	Z (Z)	[ ( [	\ ( \)	] ( ]	^ (^)			

- 1
- 2
- 3
- 4
- 5
- 6
- 7
- 8
- 9
- 10
- 11
- 12
- 13
- 14
- 15
- 16

---

## 12 DIGITAL MODE OPERATION

### ◆ TX message programming

A TX message channel C1 must be programmed, if you want to use the GPS message. The GPS message is transmitted from channel C1 only.

- ① Push **[SET•LOCK]** to enter message set mode.
  - Rotate **[DIAL]** to select “MESSAG,” if “CALLS” or “SET” is displayed.
- ② Push **[SET•LOCK]** or **[S.MW•MW]** several times until “TXM-C” appears, then push **[BAND]**.
- ③ Rotate **[DIAL]** to select the message channel.
  - One of either “C1” to “C6” flashes.
- ④ Push **[BAND]** to set into message programming condition.
  - The 1st digit blinks and channel indication stops blinking.
- ⑤ Rotate **[DIAL]** to set the desired character.
- ⑥ Push **[SET•LOCK]** to select 2nd digit, then rotate **[DIAL]** to set the desired character.
  - 2nd digit blinks (1st digit stop blinking).
  - Repeat this step for programming.
- ⑦ Push **[BAND]** to set the message.
- ⑥ Repeat steps ② to ⑥ to set another message channels.
- ⑦ Push any key below the display to exit the message set mode.

## ■ GPS operation

The ID-800H can indicate the current position (Latitude and Longitude) when a GPS receiver (compatible with an RS-232C output/NMEA format/4800 bps) is connected to [DATA] jack. And also can transmit the position data and message to other stations.

### ◇ Position indication

- ① While connecting a GPS receiver and operating digital mode, push **[SET•LOCK]** to enter set mode.
  - Rotate [DIAL] to select "SET," if "CALLS" or "MESSAG" is displayed.
- ② Push **[SET•LOCK]** or **[S.MW•MW]** several times to select the GPS setting.
  - "GPS" appears.

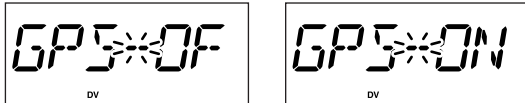

- ③ Rotate **[DIAL]** to set the GPS setting ON, then push **[BAND]** to enter the sentence formatter set mode.
- ④ Push **[SET•LOCK]** or **[S.MW•MW]** several times to select the suitable sentence formatter for the connecting GPS receiver.
  - For your position indication is necessary to set "GGA" or "RMC" is ON

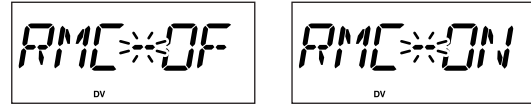

- ⑤ Push **[BAND]** to return to set mode.
- ⑥ Push **[SET•LOCK]** several times to select the position indication.

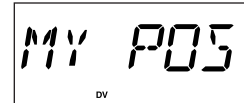

- ⑦ Push **[BAND]** to enter the position indication.
  - Latitude and longitude data appear in order as below.

- ⑧ After checking the current position, push any key below the display to return to normal operating mode.



## 12 DIGITAL MODE OPERATION

### ◇ GPS Automatic transmission

- ① While connecting a GPS receiver and operating digital mode, push **[SET•LOCK]** to enter set mode.
  - Rotate **[DIAL]** to select “SET,” if “CALLS” or “MESSAG” is displayed.
- ② Push **[SET•LOCK]** or **[S.MW•MW]** several times to select the GPS automatic transmission.
  - “GTX” appears.

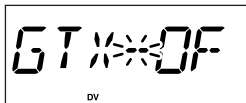

- ③ Rotate **[DIAL]** to set the interval time for the GPS automatic transmission.
  - Interval time is selectable from 0.5 (30 sec.), 1, 3, 5, 10, 30 min.

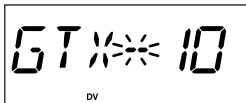

- When TX message channel “C1” is programmed, GPS transmission automatically transmits TX message “C1.”
- ④ Push any key below the display to exit set mode.

### ◇ Receiving a GPS transmission

- ① Push **[SET•LOCK]** to enter set mode.
  - Rotate **[DIAL]** to select “SET,” if “CALLS” or “MESSAG” is displayed.
- ② Push **[SET•LOCK]** or **[S.MW•MW]** several times to select the received position.
  - “RX POS” appears.

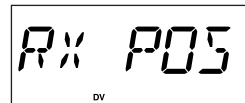

- ③ Push **[BAND]** to enter the position indication.
  - Latitude data and longitude data appear alternately.
- ④ Push **[BAND]**, then **[SET•LOCK]** to select the received GPS message.
- ⑤ Push **[BAND]** to enter the message.
  - Received message is indicated, push **[SET•LOCK]** or **[S.MW•MW]** to move the cursor to right or left, respectively.
- ⑥ After checking a received position and message, push any key below the display to return to normal operating mode.

**Count on us!**

A-6394D-1EX  
Printed in Japan  
© 2004 Icom Inc.

**Icom Inc.**  
1-1-32 Kamiminami, Hirano-ku, Osaka 547-0003 Japan