

- Set mode description ..... 11-2
  - ◇ Set mode operation ..... 11-2
  - ◇ Screen arrangement ..... 11-3
- Level set mode ..... 11-4
- ACC set mode ..... 11-7
- Display set mode ..... 11-8
- Others set mode ..... 11-10
- CF card/USB-Memory set menu ..... 11-16
  - ◇ CF/USB-Memory set screen arrangement ..... 11-16
  - ◇ Load option set mode ..... 11-17
- File saving ..... 11-18
- File loading ..... 11-19
- Changing the file name ..... 11-20
- File copying ..... 11-21
- Deleting a file ..... 11-22
- Unmount an USB-Memory ..... 11-22
- Formatting the CF card or USB-Memory ..... 11-23
- Display set (Video) mode ..... 11-24
- LCD set mode ..... 11-26

## ■ Set mode description

Set mode is used for programming infrequently changed values or conditions of functions. The IC-R9500 has a level set mode, display set mode, timer set mode, accessory set mode, others set mode and CF/USB-Memory set mode.

### ◇ Set mode operation

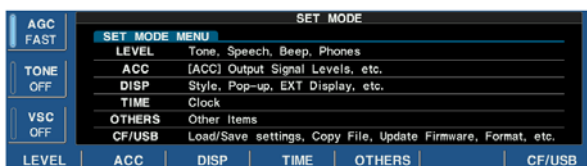
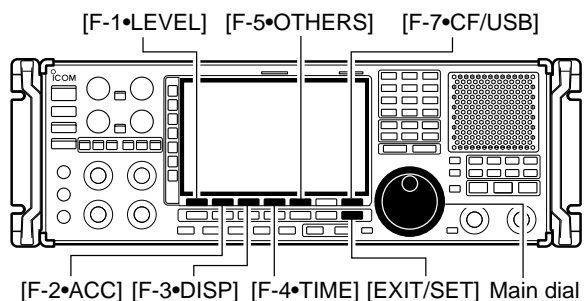

- ① Push [EXIT/SET] several times to close a multi-function screen, if necessary.
- ② Push [F-7•SET] to select set mode menu screen.
  - Pushing and holding [EXIT/SET] for 1 sec. also selects set mode menu screen.
- ③ Push [F-1•LEVEL], [F-2•ACC], [F-3•DISP], [F-4•TIME], [F-5•OTHERS] or [F-7•CF/USB] to enter the desired set mode.
- ④ For level, accessory, display and others set mode, push [F-7•WIDE] to toggle wide and normal screen.
- ⑤ Push [F-1•▲] or [F-2•▼] to select the desired item, then rotate main dial to adjust/select the desired value or condition.
  - Pushing [F-3•◀ ▶] operation may be necessary for some items.
- ⑥ Push [EXIT/SET] twice to exit set mode.

◆ Screen arrangement



• Display set mode (p. 11-8)



• Set mode menu screen (p. 11-2)

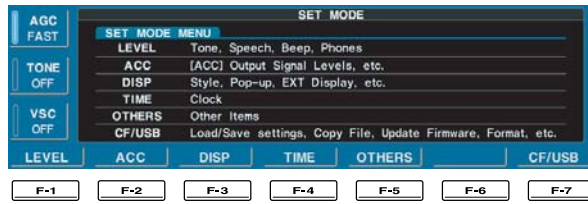

• Time set mode (p. 10-2)

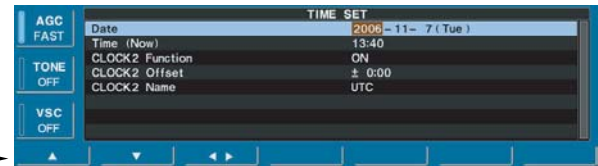

• Level set mode (p. 11-4)



• Miscellaneous (Others) set mode (p. 11-10)



• ACC set mode (p. 11-7)



• CF/USB-Memory set menu (p. 11-16)

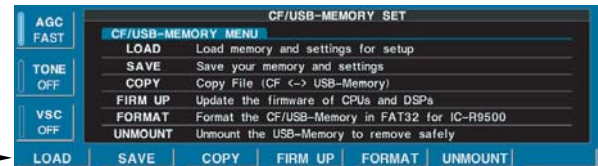

F-2 F-7

## ■ Level set mode

### FM Tone (Bass)



Sets the bass level of the receive audio in FM mode from -5 to +5. (default: 0)

### FM Tone (Treble)



Sets the treble level of the receive audio in FM mode from -5 to +5. (default: 0)

### WFM Tone (Bass)



Sets the bass level of the receive audio in WFM mode from -5 to +5. (default: 0)

### WFM Tone (Treble)



Sets the treble level of the receive audio in WFM mode from -5 to +5. (default: 0)

### AM Tone (Bass)



Sets the bass level of the receive audio in AM mode from -5 to +5. (default: 0)

### AM Tone (Treble)



Sets the treble level of the receive audio in AM mode from -5 to +5. (default: 0)

### SSB Tone (Bass)



Sets the bass level of the receive audio in SSB mode from -5 to +5. (default: 0)

### SSB Tone (Treble)



Sets the treble level of the receive audio in SSB mode from -5 to +5. (default: 0)

### CW Tone (Bass)





Sets the bass level of the receive audio in CW mode from -5 to +5. (default: 0)

### CW Tone (Treble)





Sets the treble level of the receive audio in CW mode from -5 to +5. (default: 0)

## ■ Level set mode (continued)

<b>FSK Tone (Bass)</b>		<b>0</b>
Sets the bass level of the receive audio in FSK mode from -5 to +5. (default: 0)		
<b>FSK Tone (Treble)</b>		<b>0</b>
Sets the treble level of the receive audio in FSK mode from -5 to +5. (default: 0)		
<b>De-Emphasis (FM 50k)</b>	<b>OFF</b>	
De-emphasis is the use of an amplitude-frequency characteristic complimentary to the one used for pre-emphasis prior to transmission.		
Sets the de-emphasis circuit ON and OFF when the 50 kHz width filter is used in FM mode. (default: OFF)		
<b>(FM 15k)</b>	<b>ON</b>	
Sets the de-emphasis circuit ON and OFF when the 15 kHz width filter is used in FM mode. (default: ON)		
<b>(FM 7k)</b>	<b>ON</b>	
Sets the de-emphasis circuit ON and OFF when the 7 kHz width filter is used in FM mode. (default: ON)		
<b>AF High Cut (FM 50k)</b>	<b>OFF</b>	
Sets the AF high cut filter circuit ON and OFF when the 50 kHz width filter is used in FM mode. (default: OFF)		
<b>(FM 15k)</b>	<b>ON</b>	
Sets the AF high cut filter circuit ON and OFF when the 15 kHz width filter is used in FM mode. (default: ON)		
<b>(FM 7k)</b>	<b>ON</b>	
Sets the AF high cut filter circuit ON and OFF when the 7 kHz width filter is used in FM mode. (default: ON)		
<b>(WFM)</b>	<b>OFF</b>	
Sets the AF high cut filter circuit ON and OFF in WFM mode. (default: OFF)		

■ Level set mode (continued)

<b>(AM)</b>	<b>OFF</b>
Turns the AF high cut filter circuit ON and OFF in AM mode. (default: OFF)	
<b>(SSB)</b>	<b>ON</b>
Turns the AF high cut filter circuit ON and OFF in SSB mode. (default: ON)	
<b>(CW)</b>	<b>ON</b>
Turns the AF high cut filter circuit ON and OFF in CW mode. (default: ON)	
<b>(FSK)</b>	<b>ON</b>
Turns the AF high cut filter circuit ON and OFF in FSK mode. (default: ON)	
<b>(P25)</b>	<b>ON</b>
Turns the AF high cut filter circuit ON and OFF in P25 mode. (default: ON)	
<b>Speech Level</b>	 <b>50%</b>
Sets the voice synthesizer audio output level from 0 to 100% in 1% steps. (default: 50%)	
<b>Beep Level</b>	 <b>50%</b>
Sets the key-touch beep output level from 0 to 100% in 1% steps. (default: 50%)	
<b>Beep Level Limit</b>	<b>ON</b>
Turns the key-touch beep output level limiting capability from ON and OFF. (default: ON)	
<b>Phones Level Ratio</b>	 <b>1.00</b>
Sets the ratio for audio output level from the headphone to the internal speaker from 0.60 to 1.40 range in 0.01 steps. (default: 1.00)	

## ■ ACC set mode

<b>SPEECH OUT Level</b>	 <b>50%</b>
<p>Sets the speech audio output level from [SPEECH OUT] from 0 to 100% in 1% steps.</p> <ul style="list-style-type: none"> <li>• Outputs approx. 200 mV at 50% (default) setting.</li> </ul>	

<b>S/PDIF Output Level</b>	 <b>100%</b>
<p>Sets the desired output level of [S/P DIF OUT], from 0 to 100% in 1% steps. (default: 100%)</p>	

<b>REC Remote (External)</b>	<b>OFF</b>
<p>Turns the control signal of external equipment output capability ON and OFF. (default: OFF)</p> <ul style="list-style-type: none"> <li>• OFF : No signal output from [REC REMOTE] jacks. (default)</li> <li>• ON : The [REC REMOTE] jacks shorts to ground when receiving a signal or the squelch is open.</li> </ul>	

<b>External Meter Output</b>	<b>Signal</b>
<p>Selects the squelch condition output for an external meter indication from pin 8 of [ACC].</p> <ul style="list-style-type: none"> <li>• Signal : Outputs the receiving signal strength level during receiving. (default)</li> <li>• Signal+SQL: Outputs the receiving signal strength level during receiving and outputs squelch open/close condition.</li> </ul>	

<b>External Meter Level</b>	 <b>50%</b>
<p>Sets the output level for an external meter indication from 0 to 100% range in 1% steps.</p> <ul style="list-style-type: none"> <li>• Approx. 2.5 V at 50% (default) setting for full-scale indication. (4.7 k<math>\Omega</math> impedance)</li> </ul>	

<b>Reference IN/OUT</b>	<b>OFF</b>
<p>Selects the receiver's reference signal condition from IN, OFF and OUT.</p> <ul style="list-style-type: none"> <li>• IN : Use an external reference signal for the IC-R9500.</li> <li>• OFF : No input or output of the reference signal. (default)</li> <li>• OUT : Outputs the IC-R9500 reference signal to externally connected equipment(s) for their reference.</li> </ul> <p>/// <b>NOTE:</b> If the applied reference signal is off-frequency, or no signal is applied with "IN" selection, the IC-R9500 will not work properly. Select "OFF" or "OUT" then reboot the IC-R9500.</p>	

<b>REF Adjust</b>	 <b>40%</b>
<p>Adjusts the internal reference frequency within 0 to 100% in 1% steps during frequency calibration.</p> <ul style="list-style-type: none"> <li>/// <b>NOTE:</b> Default setting is different for each receiver.</li> </ul>	

## ■ Display set mode

NOTE: "Display set (Video) mode" is described on page 11-24.

<b>Display Type</b>	<b>A</b>
Selects the desired display type from A and B. (default: A)	
<b>Signal Meter</b>	<b>S</b>
Selects the desired signal meter type from "S," "dBμ," "dBμ[EMF]" and "dBm." (default: S)	
<b>Meter Peak Hold</b>	<b>ON</b>
Turns the meter peak hold function ON or OFF. (default: ON) This function is used for the bar meter only.	
<b>Memory Name</b>	<b>ON</b>
Sets the memory name indication, during memory mode operation, ON and OFF. (default: ON)	<ul style="list-style-type: none"> <li>• ON : The programmed memory name is displayed above the frequency indication.</li> <li>• OFF : No memory name is displayed even a memory name is programmed.</li> </ul>
<b>APF-Width Popup (APF OFF→ON)</b>	<b>ON</b>
Selects the pop-up indication of the APF filter width ON and OFF when the APF function is turned ON. (default: ON)	
<b>MN-Q Popup (MN OFF→ON)</b>	<b>ON</b>
Selects the pop-up indication of the notch filter width ON and OFF when the notch filter is turned ON. (default: ON)	
<b>P25 RX ID Popup</b>	<b>ON (Dec)</b>
Sets the pop-up indication of the received ID in P25 mode ON and OFF. (default: ON)	<ul style="list-style-type: none"> <li>• ON (Hex): The received ID code (hexadecimal indication) is displayed when an ID code is received.</li> <li>• ON (Dec): The received ID code (decimal indication) is displayed when an ID code is received. (default)</li> <li>• OFF : No ID code is displayed when an ID code is displayed.</li> </ul>
<b>Screen Saver Function</b>	<b>60min</b>
Turns the screen saver function ON (15, 30 or 60 minutes) and OFF. (default: 60 min.)	The screen saver will activate when no operation is performed for the selected time period to protect the LCD from "burn-in."



## ■ Display set mode (continued)

<p><b>External Display</b></p> <p>Select "ON" when the external display is connected. (default: OFF)</p>	<p><b>OFF</b></p> <ul style="list-style-type: none"> <li>• At least 800×600 pixel resolution is required for the display.</li> </ul>
<p><b>External Display Sync Pulse</b></p> <p>Selects the suitable pulse level for the connected external display from H and L. (default: H)</p>	<p><b>H</b></p>
<p><b>Opening Message</b></p> <p>Turns the opening message screen indication capability ON and OFF. (default: ON)</p>	<p><b>ON</b></p>
<p><b>Opening Comment</b></p> <p>Sets the introductory text, up to 10-character long, displayed in the opening screen.</p> <p>Capital letters, small letters, numerals, some symbols (- / . @) and spaces can be used.</p>	<ol style="list-style-type: none"> <li>1 Push [F-5•EDIT] to select the name edit condition. <ul style="list-style-type: none"> <li>• The cursor under the 1st character blinks.</li> </ul> </li> <li>2 Push [ABC], [abc], [123] or [Symbol] to select the character group, then rotate the main dial to select the character. <ul style="list-style-type: none"> <li>• Push [ABC] or [abc] to toggle capital and small letters.</li> <li>• Push [123] or [Symbol] to toggle numerals and symbols.</li> <li>• Push [F-1•◀] or [F-2•▶] for cursor movement.</li> <li>• Push [F-3•DEL] to delete the selected character.</li> <li>• Push [F-4•SPACE] to input a space.</li> <li>• Using the receiver's keypad, [0]–[9], can also enter numerals.</li> </ul> </li> <li>3 Push [EXIT/SET] to set the name.</li> </ol>

**Others set mode****Calibration Marker** **OFF**

This item is used for a simple frequency check of the receiver. (default: OFF)

See p. 12-5 for calibration procedure.

/// **NOTE:** Turn the calibration marker OFF after checking the frequency of the receiver.

**Beep (Confirmation)** **ON**

A beep sounds each time a switch is pushed to confirm it. This function can be turned OFF for silent operation. (default: ON)

The beep output level can be set in level set mode. (p. 11-6)

**Beep Sound** **1000Hz**

Sets the desired key-touch beep sound frequency from 500 to 2000 Hz in 10 Hz steps. (default: 1000 Hz)

**[PANEL LOCK] SWITCH** **ALL**

Selects the Panel lock function activity from "ALL" and "KEY." (default: ALL)

**SPEECH Language** **English**

Selects the speech language from English and Japanese. (default: English)

**SPEECH Speed** **High**

Selects the speech speed from HIGH (faster) and LOW (slower). (default: HIGH)

**SPEECH S-Level** **ON**

The IC-R9500 speech processor has frequency, mode and signal level announcement. Signal level announcement can be deactivated if desired. (default: ON)

When "OFF" is selected, the signal level is not announced.

## ■ Others set mode (continued)

SPEECH [MODE] SWITCH	OFF
<p>Selects the operating mode speech capability when a mode switch is pushed; ON or OFF. (default: OFF)</p> <p>When “ON” is selected, the selected operating mode is announced when a mode switch is pushed.</p>	

REC SPEECH	OFF
<p>Selects the frequency speech capability when scan stops; ON or OFF.</p> <p>/// <b>NOTE:</b> Output jacks are selected depending on “SPEECH Mix” settings. See the combination of “REC SPEECH” and “SPEECH Mix” settings in the table below.</p>	<ul style="list-style-type: none"> <li>• ON : The frequency is announced through the [REC OUT]/[LINE OUT] or [SPEECH OUT] when scan stops.</li> <li>• OFF : No speech audio outputs when scan stops.</li> </ul>

SPEECH Mix	All
<p>Selects the speech audio output from the [REC OUT] or [LINE OUT].</p> <p>/// <b>NOTE:</b> See the combination of “REC SPEECH” and “SPEECH Mix” settings below table.</p>	<ul style="list-style-type: none"> <li>• All : Outputs the speech audio when speech operation is performed from the front panel or depends on above “REC SPEECH” setting. (default)</li> <li>• Operation: Outputs the speech audio when speech operation is performed from the front panel.</li> <li>• OFF : No speech audio outputs from [REC OUT] or [LINE OUT].</li> </ul>

### • Combination of REC SPEECH and SPEECH Mix settings

Switch setting		Speech operation from front panel			Scan stops		
REC SPEECH	SPEECH Mix	Internal Speaker	[REC OUT] / [LINE OUT]	[SPEECH OUT]	Internal Speaker	[REC OUT] / [LINE OUT]	[SPEECH OUT]
OFF	All	✓	✓	✓	–	–	–
	Operation	✓	✓	✓	–	–	–
	OFF	–	–	✓	–	–	–
ON	All	✓	✓	✓	✓	✓	✓
	Operation	✓	✓	✓	✓	–	✓
	OFF	–	–	✓	–	–	✓

■ Others set mode (continued)

MAIN DIAL Auto TS	High
<p>Sets the auto tuning step function for the main dial. When rotating the main dial rapidly, the tuning step automatically changes several times as selected.</p> <p>There are 2 type of auto tuning steps: HIGH (Fastest) and LOW (Faster). (default: HIGH)</p>	<ul style="list-style-type: none"> <li>• HIGH : Auto tuning step is turned ON. Fastest tuning step during rapid rotation. (default)</li> <li>• LOW : Auto tuning step is turned ON. Faster tuning step during rapid rotation.</li> <li>• OFF : Auto tuning step is turned OFF.</li> </ul>

MAIN DIAL Click Mode	Auto
<p>Sets the dial click function for the main dial from Auto or Manual.</p>	<ul style="list-style-type: none"> <li>• Auto : Sets the dial click function automatically when a tuning step is set higher than 5 kHz or changing the set mode contents, etc. (default)</li> <li>• Manual : Sets the dial click function manually.</li> </ul> <p>/// <b>NOTE:</b> When “Manual” is selected, set the next item “MAIN DIAL CLICK” ON or OFF.</p>

MAIN DIAL Click	Auto
<p>Sets the dial click function ON or OFF. This item can be set when the previous item “MAIN DIAL Click Mode” is set to “Manual.”</p> <p>/// <b>NOTE:</b> When the previous item is set to “Auto,” this item is fixed “Auto.”</p>	<ul style="list-style-type: none"> <li>• Auto : Selection can not be changed, set the previous item to “Manual” in advance. (default)</li> <li>• ON : The dial click function is ON, “CLICK” indicator appears on the display.</li> <li>• OFF : The dial click function is OFF.</li> </ul>

MAIN DIAL Click (Set mode, etc)	ON
<p>Selects the dial click function while setting the set mode items, etc. from ON and OFF. (default: ON)</p>	<ul style="list-style-type: none"> <li>• ON : The main dial click function is ON.</li> <li>• OFF : The main dial click function is OFF.</li> </ul>

MAIN DIAL Operation (SCAN)	Up/Down
<p>Selects the main dial function while scanning from OFF and Up/Down. (default: Up/Down)</p>	<ul style="list-style-type: none"> <li>• OFF : The main dial stops scan.</li> <li>• Up/Down : The main dial changes scanning direction Up or Down.</li> </ul>

AFC Limit	ON
<p>The AFC function automatically compensates the tuning when a received frequency drifts or goes off frequency.</p> <p>This item sets the AFC limit function ON and OFF.</p>	<ul style="list-style-type: none"> <li>• ON : AFC function stops to tune when frequency goes off the limited frequency range even if received frequency is off frequency. (default)</li> <li>• OFF : AFC function continues to tune until displayed frequency changes to reflect the center of the signal.</li> </ul>

## ■ Others set mode (continued)

<b>SSB/CW Synchronous Tuning</b>	<b>OFF</b>
<p>Selects the displayed frequency shift function from ON and OFF. (default: OFF)</p> <p>When this function is activated, the received signal will continue to be received even when the operating mode is changed between SSB and CW.</p> <p>/// The frequency shifting value may differ according to the CW pitch setting.</p>	<ul style="list-style-type: none"> <li>• ON : The displayed frequency shifts when the operating mode is changed between SSB and CW.</li> <li>• OFF : The displayed frequency does not shift.</li> </ul>
<b>CW Normal Side</b>	<b>LSB</b>
<p>Selects the side band used to receive CW in CW normal mode. (default: LSB)</p>	
<b>APF Type</b>	<b>SOFT</b>
<p>Sets audio filter shape for APF from SOFT and SHARP. (default : SOFT).</p>	<ul style="list-style-type: none"> <li>• SOFT : Soft filter shape makes distinguishing noise and signals easier. The audio filter width is related to the CW pitch setting.</li> <li>• SHARP : Sharp filter shape rejects interference signals. The audio filter width is fixed.</li> </ul>

■ Others set mode (continued)

CI-V Baud Rate	Auto
<p>Sets the CI-V data transfer rate. 300, 1200, 4800, 9600, 19200 bps and "Auto" are available. (default: Auto)</p> <p>When "Auto" is selected, the baud rate is automatically set according to the data rate of connected controller.</p>	

CI-V Address	72h
<p>To distinguish equipment, each CI-V transceiver or receiver has its own Icom standard address in hexadecimal code. The IC-R9500's address is 72h.</p> <p>When 2 or more IC-R9500's are connected to an optional CT-17 CI-V LEVEL CONVERTER, rotate the main dial to select a different address for each IC-R9500; the range is 01h to 7Fh.</p>	

CI-V Transceive	ON
<p>Transceive operation is possible with the IC-R9500 connected to other Icom transceivers or receivers.</p> <p>When "ON" is selected, changing the frequency, operating mode, etc. on the IC-R9500 automatically changes those of connected transceivers (or receivers) and vice versa.</p>	

RS-232C Function	CI-V
<p>Select [RS-232C] connector output data format from CI-V and Decode.</p>	<ul style="list-style-type: none"> <li>• CI-V : Outputs data in CI-V format. (default)</li> <li>• Decode : Outputs decoded contents in ASCII code format.</li> </ul>

Decode Baud Rate	9600
<p>Selects data transmission speed (Baud rate) when "Decode" is selected in "RS-232C Function" above; settings are 300, 1200, 4800, 9600 and 19200 bps. (default: 9600)</p>	

Keyboard Type	English
<p>Selects the connected keyboard type from Japanese, English, United Kingdom, French, French (Canadian), German, Portuguese, Portuguese (Brazilian), Spanish, Spanish (Latin American) and Italian. (default: English)</p>	

## ■ Others set mode (continued)

<b>Keyboard Repeat Delay</b> <span style="float: right;"><b>250ms</b></span>	
Sets the time period for delay within 100 to 1000 msec. in 50 msec. steps. (default: 250 msec.)	
When a key of the connected keyboard is pressed and held for the set period, the character is input continuously.	
<b>Keyboard Repeat Rate</b> <span style="float: right;"><b>10.9cps</b></span>	
Sets the repeating rate for the connected keyboard within 2.0 to 30.0 cps in 0.1 cps steps. (default: 10.9 cps) *cps=character per second	
When a key of the connected keyboard is pressed and held, the character is repeatedly input with the set speed.	
<b>IP Address (Valid after Reboot)</b> <span style="float: right;"><b>192.168. 0. 1</b></span>	
Sets IP address for the IC-R9500 when connecting to your PC or LAN (Local Area Network) through the Ethernet connector.	Turn the receiver power OFF then ON to make the setting effective. See p. 15-7 for details.
<b>Subnet Mask (Valid after Reboot)</b> <span style="float: right;"><b>255.255.255. 0 (24bit)</b></span>	
Sets subnet mask for the IC-R9500 when connecting to your PC or LAN (Local Area Network) through the Ethernet connector.	Turn the receiver power OFF then ON to make the setting effective. See p. 15-7 for details.

## ■ CF card/USB-Memory set menu

### ◇ CF/USB-Memory set screen arrangement

- CF/USB-Memory set menu



- Setting load screen (p. 11-19)

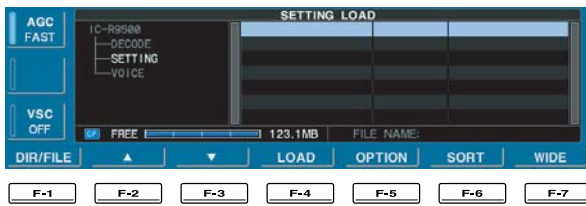

- Load option set mode (p. 11-17)

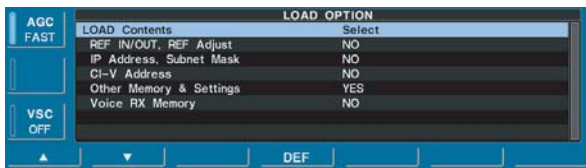

- Setting save screen (p. 11-18)

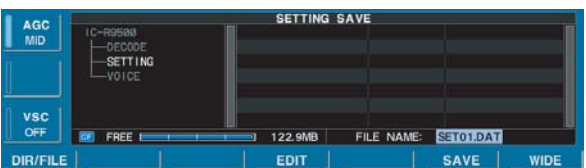

- Copy files (p. 11-21)

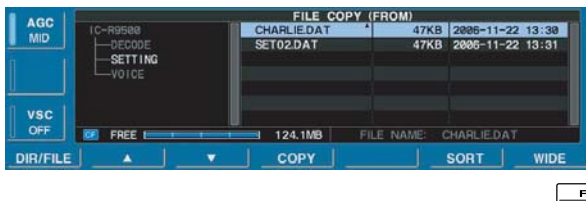

- Firmware update (p. 15-4)



- Format menu (p. 11-23)

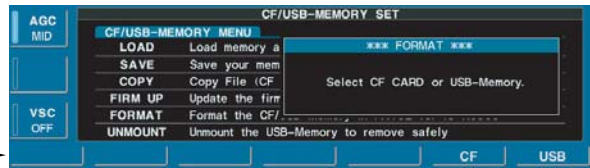

- Unmount USB-Memory (p. 11-22)

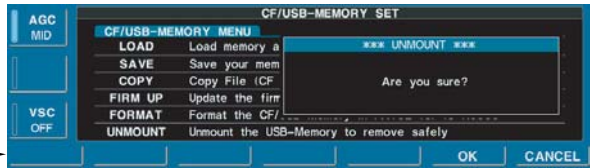



## ◇ Load option set mode

<b>LOAD Contents</b>	<b>Select</b>
Selects file loading condition from All and Select. (default: Select)	<ul style="list-style-type: none"> <li>• All : Loads and sets the all following contents.</li> <li>• Select : Loads and sets the selected contents only.</li> </ul>
<b>REF IN/OUT, REF Adjust</b>	<b>NO</b>
Selects the reference signal setting loading condition YES and NO. (default: NO).	<ul style="list-style-type: none"> <li>• YES : Loads and sets the reference signal setting.</li> <li>• NO : Use the original reference signal setting.</li> </ul>
<b>IP Address, Subnet Mask</b>	<b>NO</b>
Selects the IP address and subnet mask setting loading condition YES and NO. (default: NO).	<ul style="list-style-type: none"> <li>• YES : Loads and sets the IP address and subnet mask setting.</li> <li>• NO : Use the original IP address and subnet mask setting.</li> </ul>
<b>CI-V Address</b>	<b>NO</b>
Selects the CI-V address setting loading condition YES and NO. (default: NO).	<ul style="list-style-type: none"> <li>• YES : Loads and sets the CI-V address setting.</li> <li>• NO : Use the original CI-V address setting.</li> </ul>
<b>Other Memory &amp; Settings</b>	<b>YES</b>
Selects memory channel contents and other settings loading condition YES and NO. (default: YES).	<ul style="list-style-type: none"> <li>• YES : Loads and sets memory channel contents and other settings.</li> <li>• NO : Use the original memory channel contents and other settings.</li> </ul>
<b>Voice RX Memory</b>	<b>NO</b>
Selects the voice RX memory loading condition YES and NO. (default: NO).	<ul style="list-style-type: none"> <li>• YES : Loads and sets the voice RX memory.</li> <li>• NO : Use the original the voice RX memory.</li> </ul>

## ■ File saving

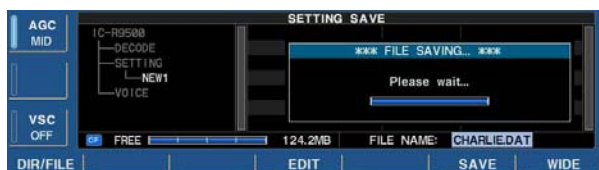
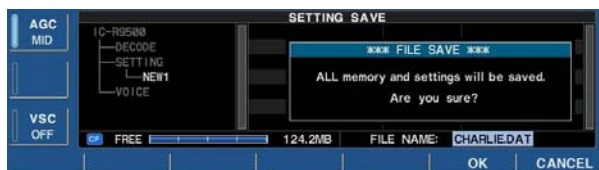
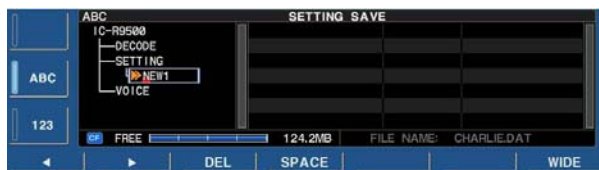
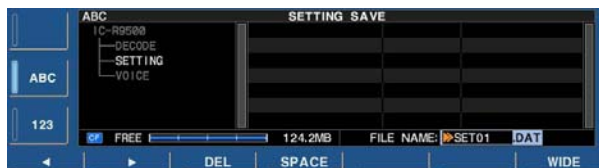
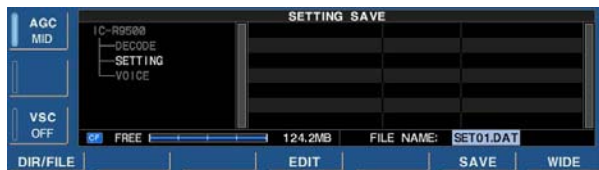
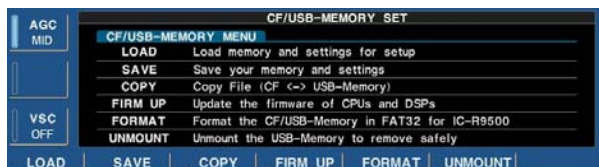
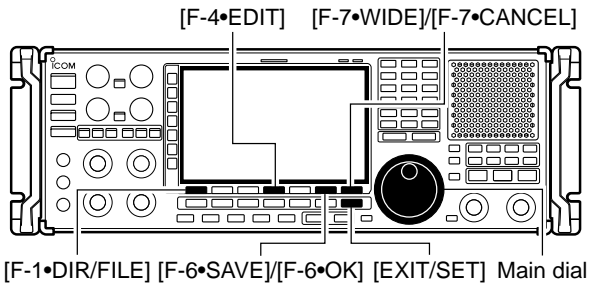

Memory channel contents, set mode settings, etc. can be saved into the CF (Compact Flash) memory card or USB-memory for backup.

- ① During set mode menu screen indication, push [F-7•CF/USB] to select CF/USB-Memory set menu screen.
- ② Push [F-2•SAVE] to select setting save screen.
- ③ Change the following conditions if desired.

### • File name:

- ① Push [F-4•EDIT] to select file name edit condition.
  - Push [F-1•DIR/FILE] several times to select the file name, if necessary.
- ② Push [ABC], [123] or [Symbol] to select the character group, then rotate the main dial to select the character.
  - Push [123] or [Symbol] to toggle numerals and symbols.
  - [ABC] : A to Z (capital letters); [123]: 0 to 9 (numerals); [Symbol]: ! # \$ % & ' ^ + = ( ) [ ] { } \_ ~ @ can be selected.
  - Push [F-1•◀] to move the cursor left, push [F-2•▶] to move the cursor right, push [F-3•DEL] to delete a character and push [F-4•SPACE] to insert a space.
- ③ Push [EXIT/SET] to set the file name.

### • Saving location

- ① Push [F-1•DIR/FILE] to select tree view screen.
  - Push and hold [F-1•DIR/FILE] for 1 sec. once or twice to select the CF card or USB-Memory, when USB memory is Inserted.
- ② Select the desired directory or folder in the CF memory card.
  - Push [F-4•◀▶] to select the upper directory.
  - Push [F-2•▲] or [F-3•▼] to select folder in the same directory.
  - Push and hold [F-4•◀▶] for 1 sec. to select a folder in the directory.
  - Push [F-5•REN/DEL] to rename the folder.
  - Push and hold [F-5•REN/DEL] for 1 sec. to delete the folder.
  - Push and hold [F-6•MAKE] for 1 sec. to making a new folder. (Edit the name with the same manner as the "• File name" above.)
- ③ Push [F-1•DIR/FILE] twice to select the file name.
- ④ Push [F-6•SAVE].
  - Confirmation screen appears.
- ⑤ Push [F-6•OK] to save.
  - After saving is completed, return to CF/USB-Memory set menu automatically.

## ■ File loading

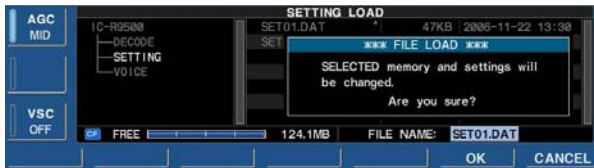
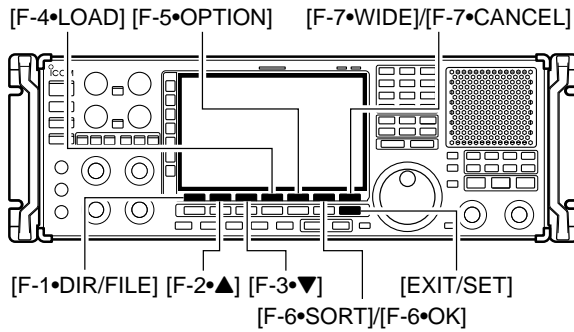

By loading the saved setting file from the CF memory card or USB-Memory, you can easily set up another IC-R9500—several operators settings can easily be applied to one IC-R9500.

- ① During set mode menu screen indication, push [F-7•CF/USB] to select CF/USB-Memory set menu screen.
- ② Push [F-1•LOAD] to select setting load screen.
- ③ Push [F-5•OPTION] to select load option set mode, then set the desired loading conditions, if desired.
  - See page 11-17 for details.
- ④ Push and hold [F-1•DIR/FILE] for 1 sec. once or twice to select the CF card or USB-Memory, when USB memory is inserted.
- ⑤ Push [F-2•▲] or [F-3•▼] to select the desired setting file.
- ⑥ Push [F-4•LOAD].
  - Confirmation screen appears.
- ⑦ Push [F-6•OK] to starts loading.
  - After the loading is completed, the message dialog, “Reboot the IC-R9500,” appears.
- ⑧ Turn the receiver power OFF then ON to make the setting effective.

## ■ Changing the file name

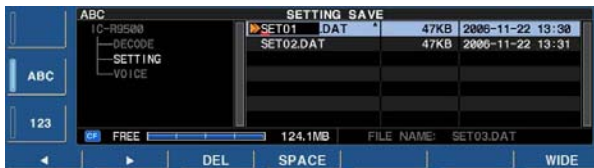
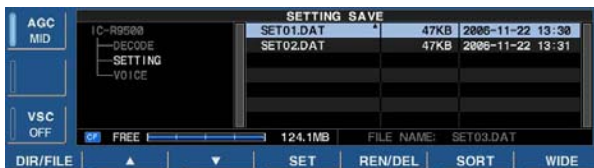
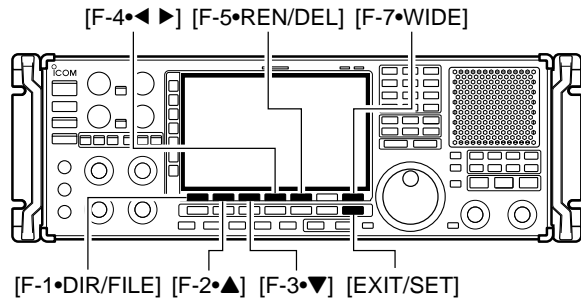

The file name, saved in the CF memory card or USB-memory, can be re-named from the receiver as desired.

- ① During setting save screen display, push [F-1•DIR/FILE] to select tree view screen.
  - Push and hold [F-1•DIR/FILE] for 1 sec. once or twice to select the CF card or USB-Memory, when USB memory is Inserted.
  - Push [F-2•▲] or [F-3•▼] to select the desired folder.
  - “DECODE,” “SETTING” and “VOICE” folders are available as the default.
  - After the folder is selected, push and hold [F-4•◀▶] for 1 sec. to display content folder(s), if available.
- ② Push [F-1•DIR/FILE] to select file list screen.
- ③ Push [F-2•▲] or [F-3•▼] to select the desired file.
- ④ Push [F-5•REN/DEL] momentarily to select the file name edit condition.
- ⑤ Push [ABC], [123] or [Symbol] to select the character group, then rotate the main dial to select the character.
  - Push [123] or [Symbol] to toggle numerals and symbols.
  - [ABC] : A to Z (capital letters); [123]: 0 to 9 (numerals); [Symbol]: ! # \$ % & ' ^ + = ( ) [ ] { } \_ ~ @ can be selected.
  - Push [F-1•◀] to move the cursor left, push [F-2•▶] to move the cursor right, push [F-3•DEL] to delete a character and push [F-4•SPACE] to insert a space.
  - Using the receiver's keypad, [0]–[9], can also enter numerals.
- ⑥ Push [EXIT/SET] to set the file name.

## ■ File copying

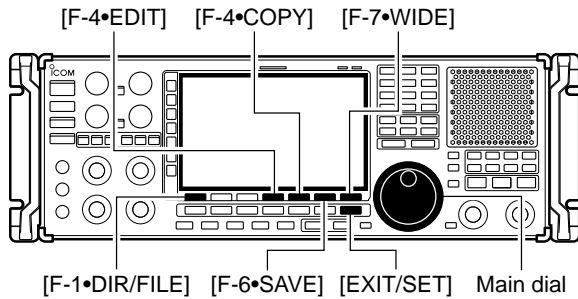

Memory channel contents, set mode settings, etc. in CF card or USB-Memory can be copied between memory devices for backup.

- ① During set mode menu screen indication, push [F-7•CF/USB] to select CF/USB-Memory set menu screen.
- ② Push [F-3•COPY] to select file copy screen.

### • Select the original file (Example Copying CF card to USB-Memory)

- ① Push [F-1•DIR/FILE] to select tree view screen.
  - Push and hold [F-1•DIR/FILE] for 1 sec. to select the CF card, if USB-Memory is selected.
  - Push [F-2•▲] or [F-3•▼] to select the desired folder.
  - After the folder is selected, push and hold [F-4•◀▶] for 1 sec. to display content folder(s), if available.
- ② Push [F-1•DIR/FILE] to select file list screen.
- ③ Push [F-2•▲] or [F-3•▼] to select the desired file.
- ④ Push [F-4•COPY] to select the file.

### • Saving location

- ① Push and hold [F-1•DIR/FILE] for 1 sec. to select the USB-Memory.
- ② Select the desired directory or folder in the USB-Memory.
  - Push [F-4•◀▶] to select the upper directory.
  - Push [F-2•▲] or [F-3•▼] to select folder in the same directory.
  - Push and hold [F-4•◀▶] for 1 sec. to select a folder in the directory.
  - Push [F-5•REN/DEL] to rename the folder.
  - Push and hold [F-5•REN/DEL] for 1 sec. to delete the folder.
  - Push [F-6•MAKE] for 1 sec. to making a new folder
- ③ Push [F-1•DIR/FILE] twice to select the file name.
  - After saving is completed, return to CF/USB-Memory set menu automatically.

## ■ Deleting a file

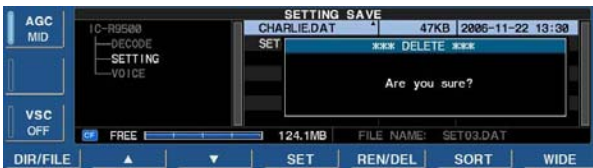
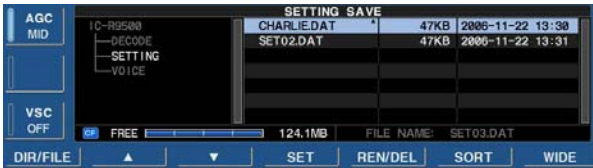

**RECOMMENDATION!** Deleting the setting file is irreversible. Confirm the contents before deleting a setting file!

- ① During setting save screen display, push [F-1•DIR/FILE] to select tree view screen.
  - Push [F-2•▲] or [F-3•▼] to select the desired folder.
  - “DECODE,” “SETTING” and “VOICE” folders are available as the default.
  - After the folder is selected, push and hold [F-2•◀▶] for 1 sec. to display content folder(s), if available.
- ② Push [F-1•DIR/FILE] to select file list screen.
- ③ Push [F-2•▲] or [F-3•▼] to select the desired file to be deleted.
- ④ Push and hold [F-5•REN/DEL] for 1 sec.
  - Confirmation screen appears.
- ⑤ Push [F-6•OK] to delete.
  - After the deleting, return to setting save screen automatically.

## ■ Unmount an USB-Memory

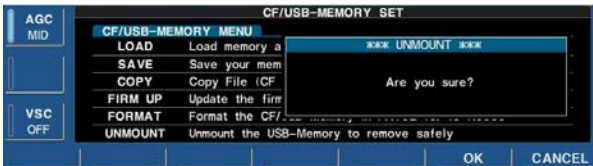

**CAUTION!** When removing the USB-Memory, unmount operation is necessary. Unless otherwise inside data of USB-Memory may be damaged.

- ① Push and hold [F-6•UNMOUNT] for 1 sec.
  - Confirmation screen appears.
- ② Push [F-6•OK] to unmount the USB-Memory.
- ③ After “USB” indication disappears, remove the USB-Memory.



## ■ Formatting the CF card or USB-Memory

Saved data in the CF card or USB-Memory can be erased.

/// **IMPORTANT!** Formatting erases all saved data in the CF card/USB-Memory. Backing up your memory device on your PC is recommended.

- ① During CF/USB-Memory set menu display, push and hold [F-4•FORMAT] for 1 sec.
  - Selection screen appears.
- ② Push [F-6•CF] or [F-7•USB] to select CF card or USB-Memory, respectively.
- ③ Push [F-6•FAT] or [F-7•FAT32] to select the format type, FAT or FAT32, respectively.
  - Confirmation screen appears.
- ④ Push [F-6•OK] to format.
  - Push [F-7•CANCEL] to cancel.
- ⑤ Returns to CF card set menu indication automatically.

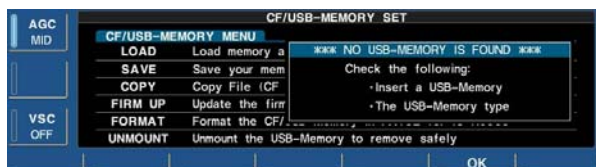
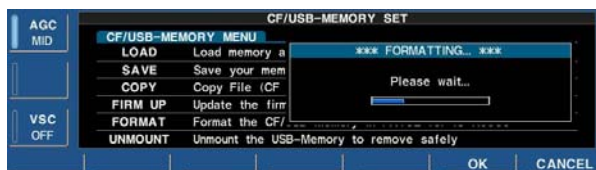
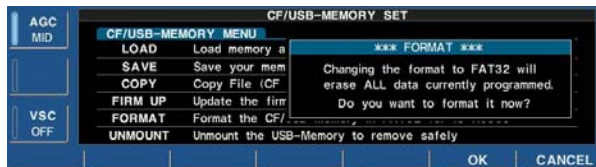
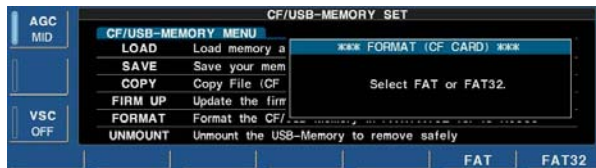
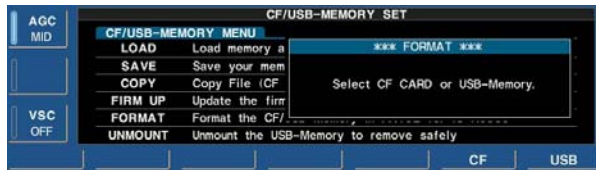

/// **NOTE:** If no USB-Memory is inserted and [F-7•USB] is selected as in step ②, an error message appears.

## ■ Display set (Video) mode

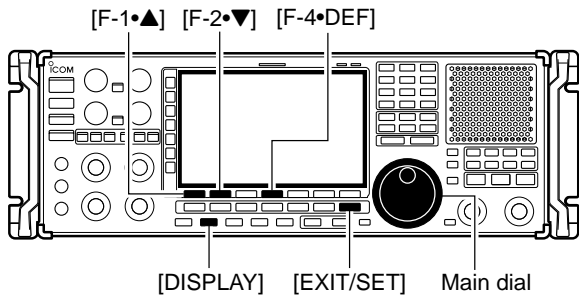

This set mode is used to set the HSB (Hue, Saturation, Brightness) color setting for video input or output, etc.

**NOTE:** "Display set mode" is described on page 11-8.

- ① Push [DISPLAY] momentarily to turn the mini TV screen, if necessary.
- ② Push and hold [DISPLAY] for 1 sec. to select the display set (Video) mode.
- ③ Push [F-1•▲] or [F-2•▼] to select the desired set item.
- ④ Set the desired condition using the main dial.
  - Push and hold [F-4•DEF] for 1 sec. to select a default condition or value.
- ⑤ Push [EXIT/SET] to exit from set mode.

**NOTE:** Video output from [DATA IN] is available an NTSC system only.

<b>TV Standard</b>	<b>NTSC M</b>
Selects the TV system of your local area from "NTSC M," "PAL B/G," "PAL I," "PAL D" and "SECAM K."	<b>NOTE:</b> Default setting is different depending on versions.

<b>VIDEO IN Contrast</b>		<b>50%</b>
Adjusts the LCD contrast of the video signal from [VIDEO IN] jack. Adjustable range is 0 (low contrast) to 100% (high contrast) in 1% steps. (default: 50%)		

<b>VIDEO IN Bright</b>		<b>50%</b>
Adjusts the LCD brightness of the video signal from [VIDEO IN] jack. Adjustable range is 0 (dark) to 100% (bright) in 1% steps. (default: 50%)		

<b>VIDEO IN Saturation</b>		<b>50%</b>
Adjusts the saturation (vibrancy of the color) of the video signal from [VIDEO IN] jack. Adjustable range is 0 (shade of gray) to 100% (vivid color) in 1% steps. (default: 50%)		

<b>VIDEO IN Hue (NTSC)</b>		<b>50%</b>
Adjusts the hue (color type) of the video signal from [VIDEO IN] jack. Adjustable range is 0 (red) to 100 (green) in 1 steps. (default: 50)	<b>NOTE:</b> This setting is available when NTSC system signal is input from [VIDEO IN] connector.	



## ■ Display set (Video) mode (continued)

VIDEO IN Trimming	ON
Trims the frame of the video signal from [VIDEO IN] jack. (default: ON)	OFF : Displays the entire area of video signal. ON : Cuts the frame area (each 4% width of upper, bottom, left and right areas) and expands the rest of area.

VIDEO IN Wide (Full)	ON
Selects the wide screen capability ON and OFF.  <b>NOTE:</b> This setting is effective for the full screen only.	

VIDEO (DATA IN) Output	VIDEO IN
Selects the output video signal from pin 2 of [DATA IN] socket. (default: VIDEO IN)	VIDEO IN : Outputs a video signal that is the same as the input from [VIDEO IN] jack. LCD : Outputs a video signal that is the same as the LCD.

VIDEO Out Horizontal Size	1
Adjusts the horizontal width of the output video signal from pin 2 of [DATA IN] socket. Adjustable range is 1 (narrow) to 4 (wide) in 1 steps. (default: 1)	

VIDEO Out Setup Level	7.5IRE
Selects the setup level of the output video signal from pin 2 [DATA IN] socket. Selectable items are 0IRE (JPN NTSC) or 7.5IRE (USA NTSC).	
<b>NOTE:</b> Default setting is different depending on versions.	

VIDEO Out Saturation	 80%
Adjusts the saturation (vibrancy of the color) of the output video signal from pin 2 of [DATA IN] jack. Adjustable range is 0 (shade of gray) to 100% (vivid color) in 1% steps. (default: 80%)	

VIDEO Out Hue	 50%
Adjusts the hue (color type) of the output video signal from pin 2 of [DATA IN] jack. Adjustable range is 0 (red) to 100 (green) in 1 steps. (default: 50)	

■ LCD set mode

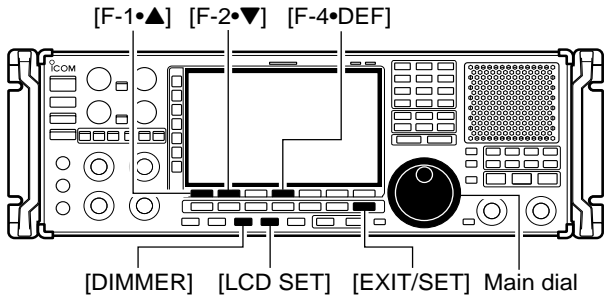

This set mode is used to set the LCD contrast, brightness and other settings for 2 condition of the dimmer function ON and OFF.

- ① Push [LCD SET] to select LCD set mode.
- ② Push [DIMMER] once or twice to select the dimmer function ON or OFF.
- ③ Push [F-1•▲] or [F-2•▼] to select the desired set item.
- ④ Set the desired condition using the main dial.
  - Push and hold [F-4•DEF] for 1 sec. to select a default condition or value.
  - Push and hold [DIMMER] for 1 sec. to reset to a default condition or value for all items at the same time.
- ⑤ Push [DIMMER] once to select the other dimmer setting, and repeat steps ③ and ④.
- ⑥ Push [EXIT/SET] to exit from set mode.

• Dimmer function OFF

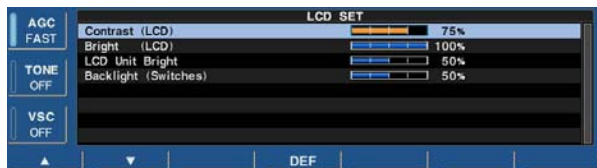

• Dimmer function ON

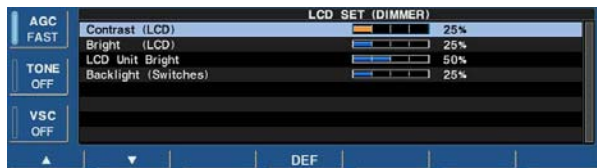

**Contrast (LCD)**



Adjusts the contrast of the LCD from 0 (low contrast) to 100% (high contrast) range in 1% steps.

Default setting:  
 Dimmer function OFF : 75%  
 Dimmer function ON : 25%

**Bright (LCD)**



Adjusts the brightness of the LCD from 0 (dark) to 100% (bright) range in 1% steps.

Default setting:  
 Dimmer function OFF : 100%  
 Dimmer function ON : 25%

**LCD Unit Bright**



Adjusts the brightness of LCD unit from 0 (dark) to 100% (bright) range in 1% steps.

Default setting:  
 Dimmer function OFF : 50%  
 Dimmer function ON : 50%

**Backlight (Switches)**



Adjusts the brightness of switch indicators from 1 (dark) to 100 (bright) range in 1 steps.

Default setting:  
 Dimmer function OFF : 50%  
 Dimmer function ON : 25%

---

■ Troubleshooting .....	12-2
◇ Receiver power .....	12-2
◇ Receiving .....	12-2
◇ Scanning .....	12-3
◇ Display .....	12-3
◇ Voice recorder .....	12-3
◇ Format memory media .....	12-3
■ Screen type selection .....	12-4
■ Main dial brake adjustment .....	12-4
■ Frequency calibration (approximate) .....	12-5
■ Opening the receiver's case .....	12-6
■ Opening the shield case .....	12-6
■ UT-122 installation .....	12-7
■ Clock backup battery replacement .....	12-7
■ Fuse replacement .....	12-8
◇ AC power input fuse .....	12-8
◇ DC output fuse .....	12-8
■ Resetting the CPU .....	12-9
■ Screen Saver Function .....	12-9

## ■ Troubleshooting

The following chart is designed to help you correct problems which are not equipment malfunctions. If you are unable to locate the cause of a problem or solve it through the use of this chart, contact your nearest Icom Dealer or Service Center.

### ◇ Receiver power

PROBLEM	POSSIBLE CAUSE	SOLUTION	REF.
Power does not come on when the [POWER] switch is pushed.	<ul style="list-style-type: none"> <li>• Power cable is improperly connected.</li> <li>• The internal power supply is turned OFF.</li> <li>• The fuse is blown.</li> </ul>	<ul style="list-style-type: none"> <li>• Re-connect the AC power cable correctly.</li> <li>• Turn the internal power supply ON.</li> <li>• Check for the cause, then replace the fuse.</li> </ul>	— p. 3-2 p.12-8

### ◇ Receiving

PROBLEM	POSSIBLE CAUSE	SOLUTION	REF.
No sounds come out from the speaker.	<ul style="list-style-type: none"> <li>• Volume level is too low.</li> <li>• The squelch is closed.</li> <li>• The RF gain is too decreases sensitivity.</li> </ul>	<ul style="list-style-type: none"> <li>• Rotate [AF] clockwise to obtain a suitable listening level.</li> <li>• Turn [SQL] to 10 o'clock position to open the squelch.</li> <li>• Rotate [RF GAIN] clockwise to obtain an enough sensitivity.</li> </ul>	p. 3-8 p. 3-8 p. 3-8
Sensitivity is too low, and only strong signals are audible.	<ul style="list-style-type: none"> <li>• The antenna is not connected properly.</li> <li>• The attenuator is activated.</li> <li>• A different antenna for HF band is selected.</li> </ul>	<ul style="list-style-type: none"> <li>• Re-connect the antenna.</li> <li>• Push [ATT] several times to select "ATT OFF."</li> <li>• Push [ANT] several times to select the correct antenna for the HF band.</li> </ul>	— p. 5-9 p. 9-3
Received audio is unclear or distorted.	<ul style="list-style-type: none"> <li>• Wrong operating mode is selected.</li> <li>• PBT function is activated.</li> <li>• Noise blanker is turned ON when receiving a strong signal.</li> <li>• Preamp is activated.</li> <li>• The noise reduction is activated and the [NR] control is too far clockwise.</li> </ul>	<ul style="list-style-type: none"> <li>• Select a suitable operating mode.</li> <li>• Push [PBT CLR] for 1 sec. to reset the function.</li> <li>• Push [NB] to turn the noise blanker OFF.</li> <li>• Push [P.AMP] once or twice to turn the function OFF.</li> <li>• Set the [NR] control for maximum readability.</li> </ul>	p. 3-7 p. 5-11 p. 5-15 p. 5-9 p. 5-16
The [ANT] switch does not function	<ul style="list-style-type: none"> <li>• The selected frequency is above 30 MHz.</li> </ul>	<ul style="list-style-type: none"> <li>• Select a frequency below 30 MHz.</li> </ul>	pgs. 3-4, 9-3
[AFC] cannot be turned ON.	<ul style="list-style-type: none"> <li>• The operating mode is <b>not</b> set in FM or WFM mode.</li> </ul>	<ul style="list-style-type: none"> <li>• Select FM or WFM mode to activate AFC.</li> </ul>	pgs. 3-7, 5-17
[AUTOTUNE](AFC) cannot be turned ON.	<ul style="list-style-type: none"> <li>• The operating mode is set in FM, WFM, FSK or P25 mode.</li> </ul>	<ul style="list-style-type: none"> <li>• Select AM, SSB or CW mode to activate AUTOTUNE.</li> </ul>	pgs. 3-7, 5-17
[VSC] cannot be turned ON.	<ul style="list-style-type: none"> <li>• The operating mode is set in CW, FSK or P25 mode.</li> </ul>	<ul style="list-style-type: none"> <li>• Select FM, WFM, AM or SSB mode to activate VSC.</li> </ul>	pgs. 3-7, 8-3
[ANF] cannot be turned ON.	<ul style="list-style-type: none"> <li>• The operating mode is <b>not</b> set in FM or WFM mode.</li> </ul>	<ul style="list-style-type: none"> <li>• Select FM or WFM mode to activate ANF.</li> </ul>	pgs. 3-7, 5-16
[NOTCH1]/[NOTCH2] cannot be turned ON.	<ul style="list-style-type: none"> <li>• The operating mode is set in FM, WFM or P25 mode.</li> </ul>	<ul style="list-style-type: none"> <li>• Select AM, SSB, CW and FSK mode to activate MN1/MN2.</li> </ul>	pgs. 3-7, 5-16
The filter width cannot be changed.	<ul style="list-style-type: none"> <li>• The operating mode is set in WFM or P25 mode.</li> </ul>	<ul style="list-style-type: none"> <li>• Select FM, AM, SSB, CW and FSK mode.</li> </ul>	pgs. 3-7, 5-12
A synthesized voice is not emitted when pushing [SPCH].	<ul style="list-style-type: none"> <li>• "SPEECH Mix" in the others set mode is OFF.</li> </ul>	<ul style="list-style-type: none"> <li>• Set "SPEECH Mix" to All or Operation in the set mode.</li> </ul>	p. 11-11

◇ Scanning

PROBLEM	POSSIBLE CAUSE	SOLUTION	REF.
Programmed scan does not stop.	<ul style="list-style-type: none"> <li>• Squelch is open.</li> </ul>	<ul style="list-style-type: none"> <li>• Readjust the [SQL] threshold.</li> </ul>	pgs. 3-8, 8-3
Scan does not start. (Programmed scan)  (Memory scan)  (Select memory scan)  (Mode select memory scan)  ( $\Delta F$ scan)  (Auto memory write scan)	<ul style="list-style-type: none"> <li>• The same frequencies have been programmed in scan edge memory channels PxA and PxB.</li> <li>• 2 or more memory channels have not been programmed.</li> <li>• 2 or more memory channels have not been designated as select channels.</li> <li>• 2 or more memory channels with desired mode have not been programmed.</li> <li>• The center frequency for <math>\Delta F</math> scan does not programmed.</li> <li>• Auto write bank is full.</li> </ul>	<ul style="list-style-type: none"> <li>• Program different frequencies in scan edge memory channel PxA and PxB.</li> <li>• Program more than 2 memory channels.</li> <li>• Designate more than 2 memory channels as select channels for the scan.</li> <li>• Program more than 2 memory channels with desired operating mode.</li> <li>• Program the center frequency for <math>\Delta F</math> scan.</li> <li>• Clear the memory channels of auto write bank.</li> </ul>	<p>p. 8-6</p> <p>pgs. 7-4, 8-11</p> <p>p. 8-12</p> <p>pgs. 7-4, 8-14</p> <p>p. 8-8</p> <p>pgs. 7-7, 8-4</p>

◇ Display

PROBLEM	POSSIBLE CAUSE	SOLUTION	REF.
The displayed frequency does not change properly.	<ul style="list-style-type: none"> <li>• The dial lock function is activated.</li> </ul>	<ul style="list-style-type: none"> <li>• Push [LOCK] to turn the function OFF.</li> </ul>	p. 9-2
The key operation on the front panel does not function.	<ul style="list-style-type: none"> <li>• The panel lock function is activated.</li> </ul>	<ul style="list-style-type: none"> <li>• Push [PANEL LOCK] to turn the function OFF.</li> </ul>	p. 9-2

◇ Voice recorder

PROBLEM	POSSIBLE CAUSE	SOLUTION	REF.
The voice recorder cannot record.	<ul style="list-style-type: none"> <li>• The selected memory media is full.</li> </ul>	<ul style="list-style-type: none"> <li>• Select a different memory media or clear the unnecessary files.</li> </ul>	p. 6-4
The voice recorder stops recording.	<ul style="list-style-type: none"> <li>• The recording memory media is full.</li> <li>• The recording file size is at maximum (2 GB).</li> </ul>	<ul style="list-style-type: none"> <li>• Select a different memory media or clear the unnecessary files.</li> <li>• Select a lower sound quality for long duration recording.</li> </ul>	<p>p. 6-4</p> <p>p. 6-6</p>

◇ Format memory media

PROBLEM	POSSIBLE CAUSE	SOLUTION	REF.
Format error appears when formatting in FAT32	<ul style="list-style-type: none"> <li>• The inserted memory media capacity is smaller than 64 MB.</li> </ul>	<ul style="list-style-type: none"> <li>• Insert a memory media larger than 64 MB or select the FAT format.</li> </ul>	p. 11-23
Format error appears when formatting in FAT	<ul style="list-style-type: none"> <li>• The inserted memory media capacity is larger than 2 GB.</li> </ul>	<ul style="list-style-type: none"> <li>• Insert a memory media smaller than 2 GB or select the FAT32 format.</li> </ul>	p. 11-23

## ■ Screen type selection

### • Screen image example— type A (default)



(Blue display)

### • Screen image example— type B



(Black display)

2 types of screen images are available in the IC-R9500.

- ① Push [EXIT/SET] several times to close multifunction screen, if necessary.
- ② Push [F-7•SET] to select set mode menu screen.
- ③ Push [F-3•DISP] to enter the display set mode.
- ④ Push [F-1•▲] or [F-2•▼] to select “Display Type” item.
- ⑤ Rotate the main dial to select the desired screen image.
  - Screen image is selectable from A and B.
- ⑥ Push [EXIT/SET] twice to exit from the display set mode.

## ■ Main dial brake adjustment

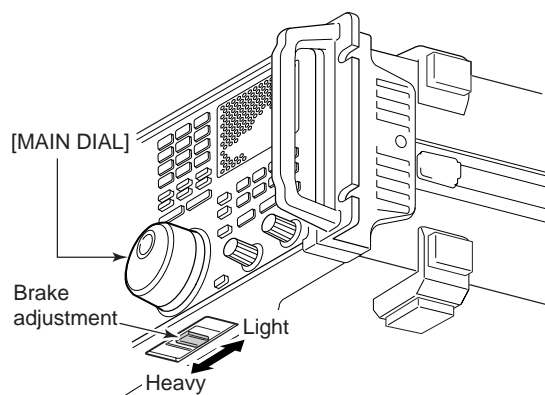

The tension of the main dial may be adjusted to suit your preference.

The brake adjustment is located on the bottom side of the front panel. See the figure at left.

Slide the brake adjustment to a comfortable tension level while turning the dial continuously and evenly in one direction.

## ■ Frequency calibration (approximate)

A very accurate frequency counter is required to calibrate the frequency of the receiver. However, a rough check may be performed by receiving radio station WWV, WWVH, or other standard frequency signals.

**CAUTION:** The IC-R9500 has been thoroughly adjusted and tested at the factory before being shipped. You should not have to re-calibrate it.

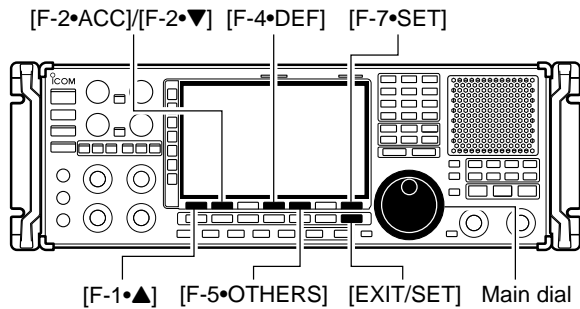

### • REF Adjust item



- ① Push [SSB] to select USB mode.
- ② Push and hold [PBT CLEAR] for 1 sec. to clear the PBT setting.
- ③ Set the frequency to the standard frequency station minus 1 kHz.
  - When receiving WWV or WWVH (at 15.00000 MHz) as a standard frequency, set the operating frequency for 14.99900 MHz.
  - Other standard frequencies can be used.
- ④ Push [EXIT/SET] several times to close a multi-function screen, if necessary.
- ⑤ Push [F-7•SET] to select set mode menu screen.
- ⑥ Push [F-5•OTHERS] to enter the others set mode.
- ⑦ Push [F-1•▲] several times to select the “Calibration Marker” item.
- ⑧ Rotate the main dial clockwise to turn the calibration marker ON.
- ⑨ Push [EXIT/SET] once to return to set mode menu screen.
- ⑩ Push [F-2•ACC] to enter accessory set mode.
- ⑪ Push [F-2•▼] several times to select the “REF Adjust” item.
- ⑫ Rotate the main dial to adjust for a zero beat with the received standard signal as shown at left.
  - Zero beat means that two signals are exactly the same frequency, resulting in a single tone being emitted.
- ⑬ Turn the calibration marker OFF in the others set mode.
- ⑭ Push [EXIT/SET] twice to exit set mode.

## ■ Opening the receiver's case

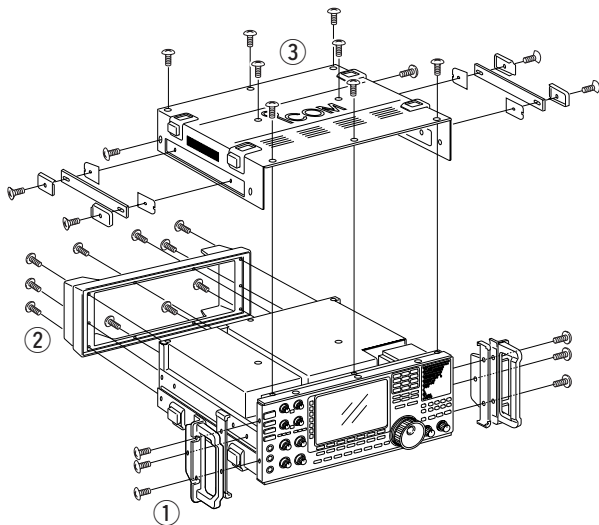

Follow the case opening procedures shown here when you want to install the optional unit UT-122, or replace the clock battery or internal fuse.

**CAUTION!** **DISCONNECT** the AC power cable from the receiver before performing any work on the receiver. Otherwise, there is danger of electric shock and/or equipment damage.

**CAUTION!** The receiver weighs approx. 20 kg (44 lb). Always have two people available to lift or turn over the receiver.

- ① Remove the 6 screws from the rack mounting handles. And remove the rack mounting handles and side plates.
- ② Remove the 10 screws from the rear of the receiver and remove the rear cover.
- ③ Remove the 8 screws from the top of the receiver and the 6 screws from the sides, then lift up the top cover.

**CAUTION: NEVER HOLD THE MAIN DIAL OR ANY OTHER KNOBS** when lifting the receiver. This may damage the receiver.

## ■ Opening the shield case

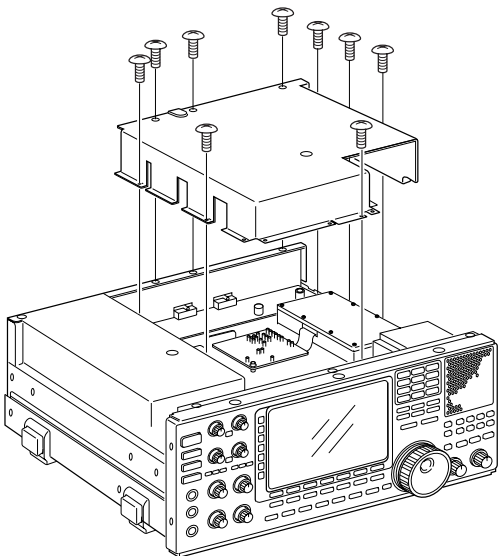

Follow the case opening procedures shown here when you want to replace the internal fuse or optional UT-122 installation.

- ① Remove the 9 screws from the shield cover of the receiver's top side.
- ② Lift up the shield cover.



## ■ UT-122 installation

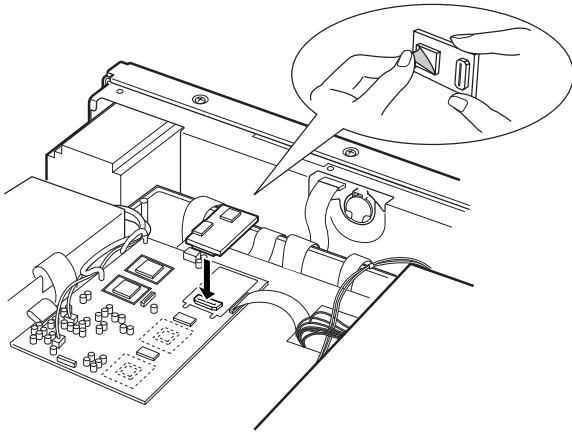

The optional UT-122 DIGITAL UNIT provides P25 (digital) mode operation.

**WARNING:** DISCONNECT the AC power cable from the AC outlet before removing the receiver's cover.

- ① Remove the top cover and inside cover as shown at left page.
- ② Connect the UT-122 as shown left.
  - Remove the protective paper from the UT-122 in advance.
- ③ Return the inside cover and top cover and screws to the original position.

## ■ Clock backup battery replacement

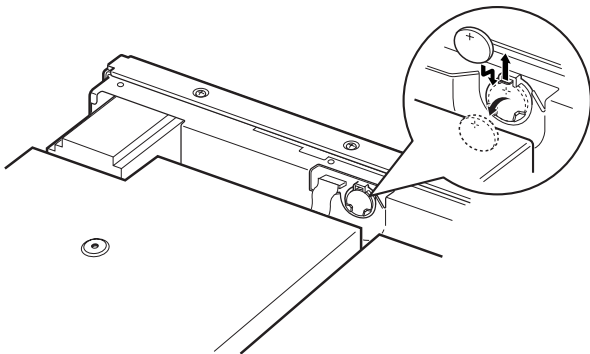

The IC-R9500 has a lithium backup battery (CR2032) inside for clock and timer functions. The usual life of the backup battery is approximately 2 years.

When the backup battery is drained, the receiver receives normally but cannot retain the current time.

**WARNING:** DISCONNECT the AC power cable from the AC outlet before removing the receiver's cover.

- ① Remove the top cover as shown at left page.
- ② Replace the clock backup battery, located on the front panel as illustrated at left.
  - Make sure the battery polarity is correct.
- ③ Return the top cover to the original position.
- ④ Set the date and time in time set mode. (p. 10-2)

## ■ Fuse replacement

IC-R9500 has two fuses for receiver protection.  
AC power input : 4 A (for 100/120 V AC versions)  
2 A (for 230/240 V AC versions)

DC output jack : 1 A

If the fuse blows or the receiver stops functioning, find the sources of the problem, if possible, and replace the damaged fuse with a new fuse of the same rating.

**WARNING:** DISCONNECT the AC power cable from the AC outlet before removing the receiver's cover. This can prevent shock to the user or damage to the receiver.

### ◇ AC power input fuse

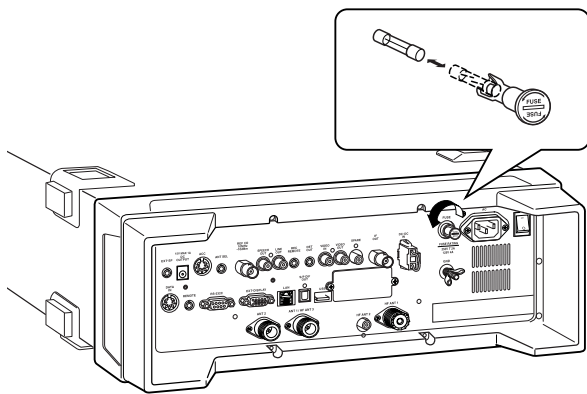

The AC power input fuse is held in the [FUSE] holder.

- ① Unscrew the [FUSE] holder using a standard screw driver.
- ② Replace the open fuse with a new, properly rated one as shown at left.

### ◇ DC output fuse

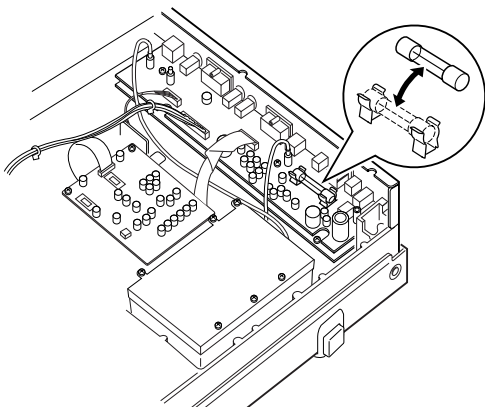

When no external DC output is available from [EXT DC] and ACC connector, the internal fuse may be open. Replace the fuse in this case.

- ① Remove the top cover and shield case as shown at page 12-6.
- ② Replace the open fuse with a new, properly rated one (FGB 1 A) as shown at left.
- ③ Replace the shield case and top cover.





- Remote interface (CI-V) information ..... 13-2
  - ◇ CI-V connection example ..... 13-2
  - ◇ Data format ..... 13-2
  - ◇ Command table ..... 13-3
  - ◇ To send/read memory contents ..... 13-10
  - ◇ Codes for memory name, bank name, opening message,  
and clock 2 name contents ..... 13-10
  - ◇ Offset frequency setting ..... 13-10
  - ◇ Tone squelch frequency setting ..... 13-10
  - ◇ DTCS squelch code setting ..... 13-10
  - ◇ NAC squelch code setting ..... 13-11
  - ◇ Selective squelch code settings ..... 13-11
  - ◇ Color setting ..... 13-11
  - ◇ Data mode with filter width setting ..... 13-11

## Remote interface (CI-V) information

### CI-V connection example

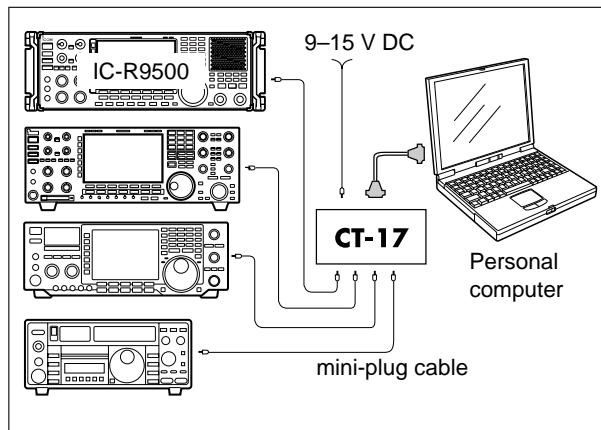

The receiver can be connected through an optional CT-17 CI-V LEVEL CONVERTER to a PC equipped with an RS-232C port. The Icom Communications Interface-V (CI-V) controls the receiver.

Up to 4 Icom CI-V transceivers or receivers can be connected to a PC equipped with an RS-232C port. See p. 11-14 for configuring the CI-V using set mode.

### Data format

The CI-V system uses the following data formats. Data formats differ according to command numbers. A data area or sub command is added for some commands.

Controller to IC-R9500

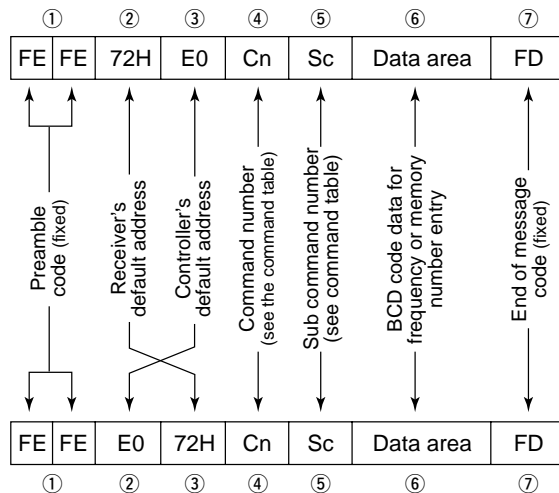

IC-R9500 to controller

OK message to controller

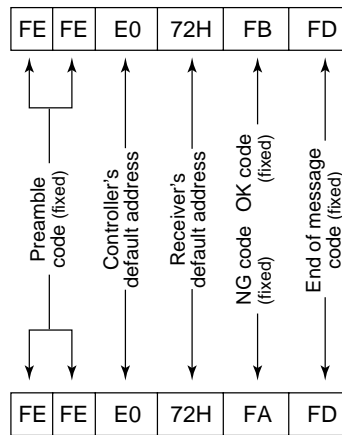

NG message to controller

### ◇ Command table

Command	Sub command	Description
00	—	Send frequency data
01	Same as command 06	Send mode data
02	—	Read upper/lower frequencies for selected band
03	—	Read operating frequency
04	—	Read operating mode
05	—	Set operating frequency
06	00 01 02 03 04 05 07 08 11 14 15 16	Select LSB Select USB Select AM Select CW Select FSK Select FM Select CW-R Select FSK-R Select S-AM(D) Select S-AM(L) Select S-AM(U) Select P25
07	—	Select (Last selected) VFO mode
08	— 0–1219*  0–12*	Select memory mode Select memory channel *0–999, 1000–1099 (A00–A99), 1100–1199 (S00–S99), 1200–1219 (P0A–P9A) Select memory bank *0–9, 10 (Bank-A), 11 (Bank-S), 12 (Bank-P)
09	—	Memory write
0A	—	Memory to VFO
0B	—	Memory clear
0C	—	Read offset frequency (see p. 13-10 for details)
0D	—	Set offset frequency (see p. 13-10 for details)
0E	00 01  02 03 04 12 13 22 23 24 42 A0 AA A1–A7  B0 B1  B2  D0	Scan stop Programmed scan (Prog 0)/ memory scan start Programmed scan (Prog 0) start $\Delta$ F scan start Auto memory write scan start Fine programmed scan start Fine $\Delta$ F scan start Memory scan start Select memory scan start Mode select memory scan start Priority scan (Prio 0) start Set $\Delta$ F scan Fixed frequency ON Set $\Delta$ F scan Fixed frequency OFF Set $\Delta$ F scan span (A1=±5 kHz; A2=±10 kHz; A3=±20 kHz; A4=±50 kHz; A5=±100 kHz; A6=±500 kHz; A7=±1 MHz) Set as non-select channel Set as select channel (1–9=★(SEL)1–9; when no data command is specified, the previous- ly set number or “★1” is selected) Set the number for select memory scan (0=ALL; 1–9=★(SEL)1–9) Set scan resume OFF

Command	Sub command	Description
0E	D1  D3  10 11 12	Set scan resume ON (Close Timer) Set scan resume ON (Close and Delay) Turn duplex OFF. (Simplex) Turn duplex ON. (DUP–) Turn duplex ON. (DUP+)
10	00 01 02 03 04 05 06 07 08 09 10 11 12 13 14	Select 1 Hz tuning step Select 10 Hz tuning step Select 100 Hz tuning step Select 1 kHz tuning step Select 2.5 kHz tuning step Select 5 kHz tuning step Select 6.25 kHz tuning step Select 9 kHz tuning step Select 10 kHz tuning step Select 12.5 kHz tuning step Select 20 kHz tuning step Select 25 kHz tuning step Select 100 kHz tuning step Select 1 MHz tuning step Select Prog tuning step
11	—	Select/read attenuator (00=OFF; 06=6 dB; 10=10 dB; 12=12 dB; 18=18 dB; 20=20 dB; 24=24 dB; 30=30 dB)
12	00 01 02	Select/read the antenna below 30 MHz. (00=HF ANT1, 01=HF ANT2, 02=HF ANT3)
13	00 01 02	Announce with voice synthesizer (00=all data; 01=frequency and S-meter level; 02=receive mode)
14	01 + Level data 02 + Level data 03 + Level data 06 + Level data 07 + Level data 08 + Level data 09 + Level data 0D + Level data 11 + Level data 12 + Level data 18 + Level data 19 + Level data 1A + Level data 1B + Level data 1C + Level data	[AF] level setting (0=max. CCW to 255=max. CW) [RF] level setting (0=max. CCW to 255=11 o'clock) [SQL] level setting (0=11 o'clock to 255=max. CW) [NR] level setting (0=min. to 255=max.) Left [TWIN PBT] setting or IF shift setting (0=max. CCW, 128=center, 255=max. CW) Right [TWIN PBT] setting (0=max. CCW, 128=center, 255=max. CW) [CW PITCH] setting (0=300 Hz, 128=600 Hz, 255=900 Hz; 5 Hz steps) [NOTCH1] setting (0=low freq. to 255=high freq.) [AGC] control setting (0=max. CCW to 255=max. CW) [NB] control setting (0=max. CCW to 255=max. CW) [CONTRAST] setting (0=max. CCW to 255=max. CW) [BRIGHT] setting (0=max. CCW to 255=max. CW) [NOTCH2] setting (0=low freq. to 255=high freq.) [BASS] setting (0=max. CCW to 255=max. CW) [TREBLE] setting (0=max. CCW to 255=max. CW)

# 13 CONTROL COMMAND

## ◇ Command table (continued)

Command	Sub command	Description
14	1D + Level data	[SCAN SPEED] setting (0=max. CCW to 255=max. CW)
	1E + Level data	[SCAN DELAY] setting (0=max. CCW to 255=max. CW)
15	01	Read squelch status
	02	Read signal (S-meter) level
	03+Sign+M-type	Read signal (dB meter) level Sign: 0/1=+/-, M-type 0/1/2=dBμ, dBμ[EMF], dBm
	04	Read center meter level
16	02	Preamp (0=OFF; 1=preamp 1; 2=preamp 2)
	12	AGC selection (0=OFF; 1=Fast; 2=Mid; 3=Slow)
	22	Noise blanker (0=OFF, 1=NB1, 2=NB2)
	32	Audio peak filter (APF type is SHARP; 0=OFF, 1=320 Hz, 2=160 Hz, 3=80 Hz), (APF type is SOFT; 0=OFF, 1=WIDE, 2=MID, 3=NAR)
	40	Noise reduction (0=OFF; 1=ON)
	41	Auto notch (0=OFF; 1=ON)
	43	Tone squelch (0=OFF; 1=ON)
	48	Manual notch1 (0=OFF; 1=ON)
	4A	AFC (0=OFF; 1=ON)
	4B	DTCS squelch (0=OFF; 1=ON)
	4C	VSC (0=OFF; 1=ON)
	4D	Manual AGC (0=OFF; 1=ON)
	4F	Twin peak filter (0=OFF; 1=ON)
	50	Dial lock (0=OFF; 1=ON)
	51	Manual notch2 (0=OFF; 1=ON)
	52	P25 Digital squelch (0=OFF; 1=NAC, 2=SEL)
19	00	Read the receiver information
1A	00	Send/read memory contents (see p. 13-10 for details)
	03	Send/read the selected filter width (AM: 0=200 Hz to 49=10 kHz; SSB, CW: 0=50 Hz to 40=3600 Hz; FSK: 0=50 Hz to 31=2700 Hz)
	04	Send/read the selected AGC time constant (AM: 0=OFF, 1=0.3 sec. to 13=8.0 sec., SSB, CW, FSK: 0=OFF, 1=0.1 sec. to 13=6.0 sec.)
	050001	Send/read FM Tone (Bass) level (0=-15 to 30=+15)
	050002	Send/read FM Tone (Treble) level (0=-15 to 30=+15)
	050003	Send/read WFM Tone (Bass) level (0=-15 to 30=+15)
	050004	Send/read WFM Tone (Treble) level (0=-15 to 30=+15)
	050005	Send/read AM Tone (Bass) level (0=-15 to 30=+15)
	050006	Send/read AM Tone (Treble) level (0=-15 to 30=+15)
	050007	Send/read SSB Tone (Bass) level (0=-15 to 30=+15)
	050008	Send/read SSB Tone (Treble) level (0=-15 to 30=+15)
050009	Send/read CW Tone (Bass) level (0=-15 to 30=+15)	
050010	Send/read CW Tone (Treble) level (0=-15 to 30=+15)	

Command	Sub command	Description
1A	050011	Send/read FSK Tone (Bass) level (0=-15 to 30=+15)
	050012	Send/read FSK Tone (Treble) level (0=-15 to 30=+15)
	050013	Send/read De-emphasis (FM 50k) (0=OFF, 1=ON)
	050014	Send/read De-emphasis (FM 15k) (0=OFF, 1=ON)
	050015	Send/read De-emphasis (FM 7k) (0=OFF, 1=ON)
	050016	Send/read AF high-cut filter (FM 50k) (0=OFF, 1=ON)
	050017	Send/read AF high-cut filter (FM 15k) (0=OFF, 1=ON)
	050018	Send/read AF high-cut filter (FM 7k) (0=OFF, 1=ON)
	050019	Send/read AF high-cut filter (WFM) (0=OFF, 1=ON)
	050020	Send/read AF high-cut filter (AM) (0=OFF, 1=ON)
	050021	Send/read AF high-cut filter (SSB) (0=OFF, 1=ON)
	050022	Send/read AF high-cut filter (CW) (0=OFF, 1=ON)
	050023	Send/read AF high-cut filter (FSK) (0=OFF, 1=ON)
	050024	Send/read AF high-cut filter (P25) (0=OFF, 1=ON)
	050025	Send/read speech level (0=0% to 255=100%)
	050026	Send/read beep gain (0=0% to 255=100%)
	050027	Send/read beep gain limit (0=OFF, 1=ON)
	050028	Send/read headphones output ratio (0=0.60 to 255=1.40)
	050029	Send/read SPEECH OUTPUT level (0=0% to 255=100%)
	050030	Send/read S/P DIF output level (0=0% to 255=100%)
	050031	Send/read REC REMOTE output (0=OFF, 1=ON)
050032	Send/read external meter output selection (0=Signal, 1=Signal+SQL)	
050033	Send/read external meter output level (0=0% to 255=100%)	
050034	Send/read reference signal in/out setting (0=IN, 1=OFF, 2=OUT)	
050035	Send/read reference signal fre- quency setting (0=0% to 255=100%)	
050036	Send/read screen image type (0=A, 1=B)	
050037	Send/read signal meter type (0=S, 1=dBμ, 2=dBμ[EMF], 3=dBm)	
050038	Send/read meter peak hold set (0=OFF, 1=ON)	
050039	Send/read memory name indica- tion setting (0=OFF, 1=ON)	
050040	Send/read audio peak filter width pop-up indication setting (0=OFF, 1=ON)	
050041	Send/read manual notch width pop-up indication setting (0=OFF, 1=ON)	



## ◇ Command table (continued)

Command	Sub command	Description
1A	050042	Send/read P25 received ID pop-up indication setting (0=OFF, 1=ON(Dec), 2=ON(Hex))
	050043	Send/read screen saver set (0=OFF, 1=15 min., 2=30 min., 3=60 min.)
	050044	Send/read output signal setting for external display (0=OFF, 1=ON)
	050045	Send/read external display synchronous pulse level setting (0=L, 1=H)
	050046	Send/read opening message indication (0=OFF, 1=ON)
	050047	Send/read opening message contents (see p. 13-10 for details)
	050048	Send/read date (20000101=1st Jan. 2000 to 20991231=31st Dec. 2099)
	050049	Send/read time (0000=00:00 to 2359=23:59)
	050050	Send/read clock 2 function (0=OFF, 1=ON)
	050051	Send/read offset time for clock 2 (240001=-24:00 to 240000=+24:00)
	050052	Send/read clock 2 name (Up to 3-character; see p. 13-10)
	050053	Send/read calibration marker (0=OFF, 1=ON)
	050054	Send/read confirmation beep (0=OFF, 1=ON)
	050055	Send/read beep audio frequency (50=500 Hz to 200=2000 Hz)
	050056	Send/read panel lock function set (0=ALL, 1=KEY)
	050057	Send/read speech language (0=English, 1=Japanese)
	050058	Send/read speech speed (0=Slow, 1=Fast)
	050059	Send/read S-level speech (0=OFF, 1=ON)
	050060	Send/read speech with a mode switch operation (0=OFF, 1=ON)
	050061	Send/read REC Speech set (0=OFF, 1=ON)
	050062	Send/read Speech Mix function set (0=OFF, 1=Operation, 2=All)
	050063	Send/read main dial auto TS (0=OFF, 1=Low, 2=High)
	050064	Send/read main dial click function mode set (0=Manual, 1=Auto)
	050065	Send/read main dial click function set (When above is Manual; 0=OFF, 1=ON or Auto; 0=OFF, 1=Auto)
	050066	Send/read main dial click (set mode, etc) function (0=OFF, 1=ON)
	050067	Send/read main dial operation during scan (0=OFF, 1=Up/Down)
	050068	Send/read AFC limit set (0=OFF, 1=ON)
050069	Send/read SSB/CW synchronous tuning function (0=OFF, 1=ON)	
050070	Send/read CW normal side set (0=LSB, 1=USB)	
050071	Send/read APF type (0=SHARP, 1=SOFT)	

Command	Sub command	Description
1A	050072	Send/read CI-V transceiver set (0=OFF, 1=ON)
	050073	Send/read RS-232C function (0=CI-V, 1=Decode)
	050074	Send/read RS-232C decode speed (0=300, 1=1200, 2=4800, 3=9600, 4=19200)
	050075	Send/read keyboard type (00=English, 01=Japanese, 02=United Kingdom, 03=French, 04=French (Canadian), 05=German, 06=Portuguese, 07=Portuguese (Brazilian), 08=Spanish, 09=Spanish (Latin American), 10=Italian)
	050076	Send/read keyboard repeat delay (10=100 msec. to 100=1000 msec.)
	050077	Send/read keyboard repeat speed (0=2.0 cps to 31=30.0 cps)
	050078	Send/read IP address set (0000000000000001=0.0.0.1 to 0255025502550255=255.255.255.255)
	050079	Send/read subnet mask (1=128.0.0.0 to 30=255.255.255.252)
	050080	Send/read TV type (0=NTSC M, 1=PAL B/G, 2=PAL I, 3=PAL D, 4=SECAM K)
	050081	Send/read the LCD contrast of the video signal from [VIDEO IN] (0=0% to 255=100%)
	050082	Send/read the LCD brightness of the video signal from [VIDEO IN] (0=0% to 255=100%)
	050083	Send/read the saturation of the video signal from [VIDEO IN] (0=0% to 255=100%)
	050084	Send/read the hue of the video signal from [VIDEO IN] (0=0% to 255=100%)
	050085	Send/read the frame trimming of the video signal from [VIDEO IN]. (0=OFF, 1=ON)
	050086	Send/read the wide screen set. (0=OFF, 1=ON)
	050087	Send/read the output video signal from [DATA IN] (0=VIDEO IN, 1=LCD)
	050088	Send/read the width of the output video signal from [DATA IN] (0=1 (narrow) to 3=4 (wide))
	050089	Send/read setup of the output video signal from [DATA IN] (0=0IRE (JPN NTSC), 1=7.5IRE (USA NTSC))
	050090	Send/read output saturation level from [DATA IN] (0=0% to 255=100%)
	050091	Send/read output hue level from [DATA IN]. (0=0% to 255=100%)
050092	Send/read the LCD contrast with dimmer OFF condition (0=0% to 255=100%)	
050093	Send/read the LCD brightness with dimmer OFF condition (0=0% to 255=100%)	

## ◇ Command table (continued)

Command	Sub command	Description
1A	050094	Send/read the LCD unit brightness with dimmer OFF condition (0=0% to 255=100%)
	050095	Send/read the key backlight with dimmer OFF condition (0=0% to 255=100%)
	050096	Send/read the LCD contrast with dimmer ON condition (0=0% to 255=100%)
	050097	Send/read the LCD brightness with dimmer ON condition (0=0% to 255=100%)
	050098	Send/read the LCD unit brightness with dimmer ON condition (0=0% to 255=100%)
	050099	Send/read the key backlight with dimmer ON condition (0=0% to 255=100%)
	050100	Send/read scope max. hold (0=OFF, 1=ON)
	050101	Send/read scope center frequency set (0=Filter center, 1=Carrier point center, 2=Carrier point center (Abs. Freq.))
	050102	Send/read waveform color for receiving signal (see p. 13-11 for details)
	050103	Send/read waveform color for max. hold (see p. 13-11 for details)
	050104	Send/read marker color for receiving signal (see p. 13-11 for details)
	050105	Send/read marker color for max. hold (see p. 13-11 for details)
	050106	Send/read scope peak excursion (0=0 dB to 80=80 dB)
	050107	Send/read scope peak threshold (0=-100 dB to 100=0 dB)
	050108	Send/read voice recorder's short play time (3=3 sec. to 10=10 sec.)
	050109	Send/read voice recorder short record time (5=5 sec. to 30=30 sec.)
	050110	Send/read voice recorder's recording quality (0=SQ1 (8 kHz), 1=SQ2 (12 kHz), 2=HQ1 (16 kHz) 3=HQ2(24 kHz) 4=SHQ (48 kHz))
	050111	Send/read REC remote set (0=OFF, 1=ON)
	050112	Send/read SPEECH Mix set (0=OFF, 1=Operation, 2=All)
050113	Send/read speech mix level (0=0% (Receive audio only) to 255=100% (Speech audio only))	
050114	Send/read memory bank limit set for memory channel selection (0=OFF, 1=ON)	
050115	Send/read memory bank limit set for memory scan (0=OFF, 1=ON)	
050116	Send/read memory bank name (Bank-0) (see p. 13-10 for details)	
050117	Send/read memory bank name (Bank-1) (see p. 13-10 for details)	

Command	Sub command	Description
1A	050118	Send/read memory bank name (Bank-2) (see p. 13-10 for details)
	050119	Send/read memory bank name (Bank-3) (see p. 13-10 for details)
	050120	Send/read memory bank name (Bank-4) (see p. 13-10 for details)
	050121	Send/read memory bank name (Bank-5) (see p. 13-10 for details)
	050122	Send/read memory bank name (Bank-6) (see p. 13-10 for details)
	050123	Send/read memory bank name (Bank-7) (see p. 13-10 for details)
	050124	Send/read memory bank name (Bank-8) (see p. 13-10 for details)
	050125	Send/read memory bank name (Bank-9) (see p. 13-10 for details)
	050126	Send/read memory bank name (Bank-A) (see p. 13-10 for details)
	050127	Send/read memory bank name (Bank-S) (see p. 13-10 for details)
	050128	Set/read FFT scope averaging set for FSK decoder (0=OFF, 1=2, 2=3, 3=4)
	050129	Set/read FFT scope waveform color set for FSK decoder (see p. 13-11 for details)
	050130	Send/read FSK decode USOS (0=OFF, 1=ON)
	050131	Send/read FSK decode new line code (0=CR,LF,CR+LF, 1=CR+LF)
	050132	Send/read clock selection for time stamp (0=Local time, 1=Clock 2)
	050133	Send/read frequency stamp (0=OFF, 1=ON)
	050134	Send/read FSK received text font color (see p. 13-11 for details)
	050135	Send/read time stamp text font color (see p. 13-11 for details)
	050136	Send/read skip scan set (0=OFF, 1=ON)
	050137	Send/read auto memory scan memory clear set (0=OFF, 1=[AUTO] Long Push, 2=ON)
	050138	Send/read auto scan screen set when scan start (0=OFF, 1=ON)
	050139	Send/read NB1 depth (0=1 to 9=10)
	050140	Send/read NB1 width (0=0 to 255=100)
	050141	Send/read NB2 depth (0=1 to 9=10)
	050142	Send/read NB2 width (0=0 to 255=100)
	050143	Send/read TS (1 Hz) as selectable tuning step for FM (0=OFF, 1=ON)
	050144	Send/read TS (10 Hz) as selectable tuning step for FM (0=OFF, 1=ON)
	050145	Send/read TS (100 Hz) as selectable tuning step for FM (0=OFF, 1=ON)
	050146	Send/read TS (1 kHz) as selectable tuning step for FM (0=OFF, 1=ON)

## ◇ Command table (continued)

Command	Sub command	Description
1A	050147	Send/read TS (2.5 kHz) as selectable tuning step for FM (0=OFF, 1=ON)
	050148	Send/read TS (5 Hz) as selectable tuning step for FM (0=OFF, 1=ON)
	050149	Send/read TS (6.25 kHz) as selectable tuning step for FM (0=OFF, 1=ON)
	050150	Send/read TS (9 kHz) as selectable tuning step for FM (0=OFF, 1=ON)
	050151	Send/read TS (10 kHz) as selectable tuning step for FM (0=OFF, 1=ON)
	050152	Send/read TS (12.5 kHz) as selectable tuning step for FM (0=OFF, 1=ON)
	050153	Send/read TS (20 kHz) as selectable tuning step for FM (0=OFF, 1=ON)
	050154	Send/read TS (25 kHz) as selectable tuning step for FM (0=OFF, 1=ON)
	050155	Send/read TS (100 kHz) as selectable tuning step for FM (0=OFF, 1=ON)
	050156	Send/read TS (1 MHz) as selectable tuning step for FM (0=OFF, 1=ON)
	050157	Send/read TS (PROG) as selectable tuning step for FM (0=OFF, 1=ON)
	050158	Send/read TS (1 Hz) as selectable tuning step for WFM (0=OFF, 1=ON)
	050159	Send/read TS (10 Hz) as selectable tuning step for WFM (0=OFF, 1=ON)
	050160	Send/read TS (100 Hz) as selectable tuning step for WFM (0=OFF, 1=ON)
	050161	Send/read TS (1 kHz) as selectable tuning step for WFM (0=OFF, 1=ON)
	050162	Send/read TS (2.5 kHz) as selectable tuning step for WFM (0=OFF, 1=ON)
	050163	Send/read TS (5 Hz) as selectable tuning step for WFM (0=OFF, 1=ON)
	050164	Send/read TS (6.25 kHz) as selectable tuning step for WFM (0=OFF, 1=ON)
	050165	Send/read TS (9 kHz) as selectable tuning step for WFM (0=OFF, 1=ON)
	050166	Send/read TS (10 kHz) as selectable tuning step for WFM (0=OFF, 1=ON)
050167	Send/read TS (12.5 kHz) as selectable tuning step for WFM (0=OFF, 1=ON)	
050168	Send/read TS (20 kHz) as selectable tuning step for WFM (0=OFF, 1=ON)	

Command	Sub command	Description
1A	050169	Send/read TS (25 kHz) as selectable tuning step for WFM (0=OFF, 1=ON)
	050170	Send/read TS (100 kHz) as selectable tuning step for WFM (0=OFF, 1=ON)
	050171	Send/read TS (1 MHz) as selectable tuning step for WFM (0=OFF, 1=ON)
	050172	Send/read TS (PROG) as selectable tuning step for WFM (0=OFF, 1=ON)
	050173	Send/read TS (1 Hz) as selectable tuning step for AM (0=OFF, 1=ON)
	050174	Send/read TS (10 Hz) as selectable tuning step for AM (0=OFF, 1=ON)
	050175	Send/read TS (100 Hz) as selectable tuning step for AM (0=OFF, 1=ON)
	050176	Send/read TS (1 kHz) as selectable tuning step for AM (0=OFF, 1=ON)
	050177	Send/read TS (2.5 kHz) as selectable tuning step for AM (0=OFF, 1=ON)
	050178	Send/read TS (5 Hz) as selectable tuning step for AM (0=OFF, 1=ON)
	050179	Send/read TS (6.25 kHz) as selectable tuning step for AM (0=OFF, 1=ON)
	050180	Send/read TS (9 kHz) as selectable tuning step for AM (0=OFF, 1=ON)
	050181	Send/read TS (10 kHz) as selectable tuning step for AM (0=OFF, 1=ON)
	050182	Send/read TS (12.5 kHz) as selectable tuning step for AM (0=OFF, 1=ON)
	050183	Send/read TS (20 kHz) as selectable tuning step for AM (0=OFF, 1=ON)
	050184	Send/read TS (25 kHz) as selectable tuning step for AM (0=OFF, 1=ON)
	050185	Send/read TS (100 kHz) as selectable tuning step for AM (0=OFF, 1=ON)
	050186	Send/read TS (1 MHz) as selectable tuning step for AM (0=OFF, 1=ON)
	050187	Send/read TS (PROG) as selectable tuning step for AM (0=OFF, 1=ON)
	050188	Send/read TS (1 Hz) as selectable tuning step for SSB (0=OFF, 1=ON)
	050189	Send/read TS (10 Hz) as selectable tuning step for SSB (0=OFF, 1=ON)
	050190	Send/read TS (100 Hz) as selectable tuning step for SSB (0=OFF, 1=ON)

◇ Command table (continued)

Command	Sub command	Description
1A	050191	Send/read TS (1 kHz) as selectable tuning step for SSB (0=OFF, 1=ON)
	050192	Send/read TS (2.5 kHz) as selectable tuning step for SSB (0=OFF, 1=ON)
	050193	Send/read TS (5 Hz) as selectable tuning step for SSB (0=OFF, 1=ON)
	050194	Send/read TS (6.25 kHz) as selectable tuning step for SSB (0=OFF, 1=ON)
	050195	Send/read TS (9 kHz) as selectable tuning step for SSB (0=OFF, 1=ON)
	050196	Send/read TS (10 kHz) as selectable tuning step for SSB (0=OFF, 1=ON)
	050197	Send/read TS (12.5 kHz) as selectable tuning step for SSB (0=OFF, 1=ON)
	050198	Send/read TS (20 kHz) as selectable tuning step for SSB (0=OFF, 1=ON)
	050199	Send/read TS (25 kHz) as selectable tuning step for SSB (0=OFF, 1=ON)
	050200	Send/read TS (100 kHz) as selectable tuning step for SSB (0=OFF, 1=ON)
	050201	Send/read TS (1 MHz) as selectable tuning step for SSB (0=OFF, 1=ON)
	050202	Send/read TS (PROG) as selectable tuning step for SSB (0=OFF, 1=ON)
	050203	Send/read TS (1 Hz) as selectable tuning step for CW (0=OFF, 1=ON)
	050204	Send/read TS (10 Hz) as selectable tuning step for CW (0=OFF, 1=ON)
	050205	Send/read TS (100 Hz) as selectable tuning step for CW (0=OFF, 1=ON)
	050206	Send/read TS (1 kHz) as selectable tuning step for CW (0=OFF, 1=ON)
	050207	Send/read TS (2.5 kHz) as selectable tuning step for CW (0=OFF, 1=ON)
	050208	Send/read TS (5 Hz) as selectable tuning step for CW (0=OFF, 1=ON)
	050209	Send/read TS (6.25 kHz) as selectable tuning step for CW (0=OFF, 1=ON)
	050210	Send/read TS (9 kHz) as selectable tuning step for CW (0=OFF, 1=ON)
050211	Send/read TS (10 kHz) as selectable tuning step for CW (0=OFF, 1=ON)	
050212	Send/read TS (12.5 kHz) as selectable tuning step for CW (0=OFF, 1=ON)	

Command	Sub command	Description
1A	050213	Send/read TS (20 kHz) as selectable tuning step for CW (0=OFF, 1=ON)
	050214	Send/read TS (25 kHz) as selectable tuning step for CW (0=OFF, 1=ON)
	050215	Send/read TS (100 kHz) as selectable tuning step for CW (0=OFF, 1=ON)
	050216	Send/read TS (1 MHz) as selectable tuning step for CW (0=OFF, 1=ON)
	050217	Send/read TS (PROG) as selectable tuning step for CW (0=OFF, 1=ON)
	050218	Send/read TS (1 Hz) as selectable tuning step for FSK (0=OFF, 1=ON)
	050219	Send/read TS (10 Hz) as selectable tuning step for FSK (0=OFF, 1=ON)
	050220	Send/read TS (100 Hz) as selectable tuning step for FSK (0=OFF, 1=ON)
	050221	Send/read TS (1 kHz) as selectable tuning step for FSK (0=OFF, 1=ON)
	050222	Send/read TS (2.5 kHz) as selectable tuning step for FSK (0=OFF, 1=ON)
	050223	Send/read TS (5 Hz) as selectable tuning step for FSK (0=OFF, 1=ON)
	050224	Send/read TS (6.25 kHz) as selectable tuning step for FSK (0=OFF, 1=ON)
	050225	Send/read TS (9 kHz) as selectable tuning step for FSK (0=OFF, 1=ON)
	050226	Send/read TS (10 kHz) as selectable tuning step for FSK (0=OFF, 1=ON)
	050227	Send/read TS (12.5 kHz) as selectable tuning step for FSK (0=OFF, 1=ON)
	050228	Send/read TS (20 kHz) as selectable tuning step for FSK (0=OFF, 1=ON)
	050229	Send/read TS (25 kHz) as selectable tuning step for FSK (0=OFF, 1=ON)
	050230	Send/read TS (100 kHz) as selectable tuning step for FSK (0=OFF, 1=ON)
	050231	Send/read TS (1 MHz) as selectable tuning step for FSK (0=OFF, 1=ON)
	050232	Send/read TS (PROG) as selectable tuning step for FSK (0=OFF, 1=ON)
050233	Send/read TS (1 Hz) as selectable tuning step for P25 (0=OFF, 1=ON)	
050234	Send/read TS (10 Hz) as selectable tuning step for P25 (0=OFF, 1=ON)	

## ◇ Command table (continued)

Command	Sub command	Description	Command	Sub command	Description
1A	050235	Send/read TS (100 Hz) as selectable tuning step for P25 (0=OFF, 1=ON)	1B	01	Set/read TSQL tone frequency. (see p. 13-10 for details)
	050236	Send/read TS (1 kHz) as selectable tuning step for P25 (0=OFF, 1=ON)		02	Set/read DTCS squelch code (see p. 13-10 for details)
	050237	Send/read TS (2.5 kHz) as selectable tuning step for P25 (0=OFF, 1=ON)		03	Set/read NAC squelch code (see p. 13-11 for details)
	050238	Send/read TS (5 Hz) as selectable tuning step for P25 (0=OFF, 1=ON)		04	Set/read TGID for selective squelch (see p. 13-11 for details)
	050239	Send/read TS (6.25 kHz) as selectable tuning step for P25 (0=OFF, 1=ON)		05	Set/read UNIT ID for selective squelch (see p. 13-11 for details)
	050240	Send/read TS (9 kHz) as selectable tuning step for P25 (0=OFF, 1=ON)	1D	00	Send/read remote function set (0=OFF, 1=REMOTE1 (locks VRs only), 2=REMOTE2 (locks VRs, Keys, and dials))
	050241	Send/read TS (10 kHz) as selectable tuning step for P25 (0=OFF, 1=ON)			
	050242	Send/read TS (12.5 kHz) as selectable tuning step for P25 (0=OFF, 1=ON)			
	050243	Send/read TS (20 kHz) as selectable tuning step for P25 (0=OFF, 1=ON)			
	050244	Send/read TS (25 kHz) as selectable tuning step for P25 (0=OFF, 1=ON)			
	050245	Send/read TS (100 kHz) as selectable tuning step for P25 (0=OFF, 1=ON)			
	050246	Send/read TS (1 MHz) as selectable tuning step for P25 (0=OFF, 1=ON)			
	050247	Send/read TS (PROG) as selectable tuning step for P25 (0=OFF, 1=ON)			
	050248	Send/read CW pitch set (0=300 Hz to 120=900 Hz in 5 Hz steps)			
	050249	Send/read FSK RX frequency (0=Mark(Space), 1=Mark/Space Center)			
	050250	Send/read FSK tone frequency (0=1275 Hz, 1=1500 Hz, 2=1615 Hz, 3=2125 Hz)			
	050251	Send/read FSK shift width (0=170 Hz, 1=200 Hz, 2=425 Hz, 3=800 Hz, 4=850 Hz)			
	08	Send/read DSP filter shape (0= sharp, 1= soft)			
	09	Send/read roofing filter set (FM/AM/SSB/CW/FSK; 0=3 kHz, 1=6 kHz, 2=15 kHz, 3=50 kHz, WFM; 4=240 kHz, P25; 2=15 kHz)			
	0A	Send/read manual notch1 width (0=Wide, 1=Mid., 2=Nar.)			
	0B	Send/read manual notch2 width (0=Wide, 1=Mid., 2=Nar.)			

## 13 CONTROL COMMAND

### ◆ To send/read memory contents

When sending or reading memory contents, additional codes must be added to appoint the memory channel as follows.

➔ Additional code: 0000–1219

#### • Memory channel code

Code	Bank number	Memory Channel
0000–0999	Bank-0–Bank-9	0–999
1000–1099	Bank-A (Auto)	A00–A99
1100–1199	Bank-S (Skip)	S00–S99
1200–1219	Bank-P (Scan edge)	P0A–P9B

#### • Memory bank code

Code	Bank number
00–09	Bank-0–Bank-9
10	Bank-A (Auto)
11	Bank-S (Slip)
12	Bank-P (Scan edge)

### ◆ Codes for memory name, bank name, opening message and clock 2 name contents

To send or read the desired memory name settings, the character codes as follows are used.

#### • Character's code

Character	ASCII code	Description
0–9	30–39	Numerals
A–Z	41–5A	Alphabetical characters
a–z	61–7A	Alphabetical characters
space	20	Word space

#### • Character's code— Symbols

Character	ASCII code	Character	ASCII code
!	21	#	23
\$	24	%	25
&	26	¥	5C
?	3F	"	22
,	27	`	60
^	5E	+	2B
–	2D	*	2A
/	2F	.	2E
,	2C	:	3A
;	3B	=	3D
<	3C	>	3E
(	28	)	29
[	5B	]	5D
{	7B	}	7D
	7C	_	5F
–	7E	@	40

### ◆ Offset frequency setting

The following data sequence is used when sending or reading the offset frequency setting.

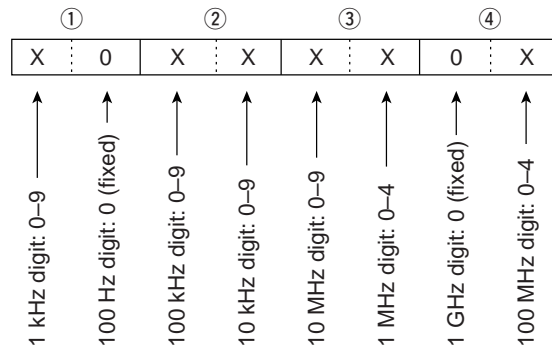

### ◆ Tone squelch frequency setting

The following data sequence is used when sending or reading the tone frequency setting.

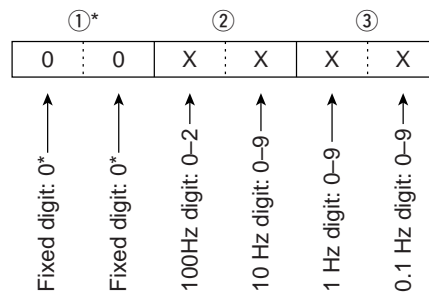

\*Not necessary when setting a frequency.

### ◆ DTCS squelch code setting

The following data sequence is used when sending or reading the DTCS code setting.

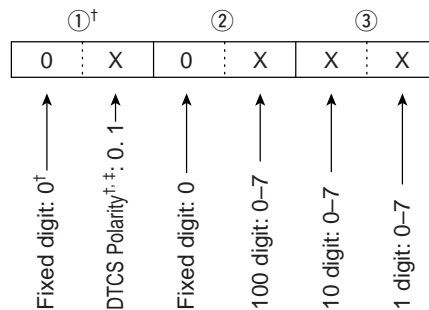

†Not necessary when normal is set.

‡0=Normal, 1=Reverse

◆ **NAC squelch code setting**

The following data sequence is used when sending or reading the NAC code setting.

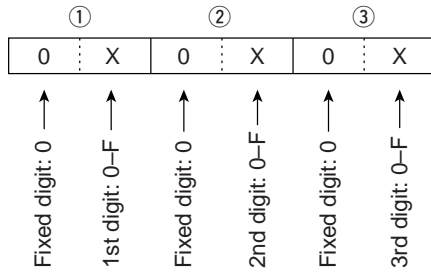

Selectable NAC: 0 0 0 – F F F

◆ **Color setting**

The following data sequence is used when sending or reading the color setting.

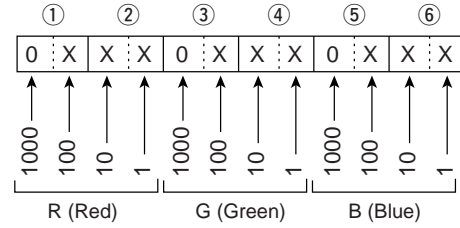

Using 0000–0255 for each color element.

◆ **Selective squelch code settings**

• **TGID setting**

The following data sequence is used when sending or reading the TGID code setting.

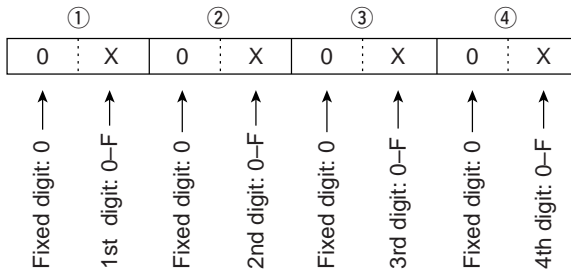

Selectable TGID: 0 0 0 0 – F F F F

• **UNIT ID setting**

The following data sequence is used when sending or reading the UNIT ID code setting.

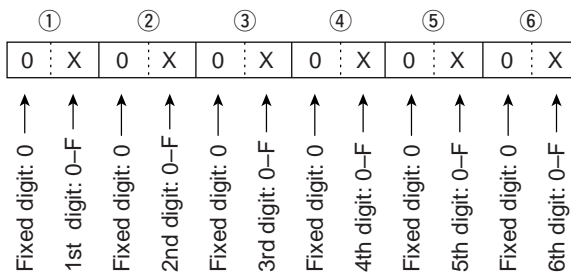

Selectable UNIT ID: 0 0 0 0 0 1 – 9 8 9 6 7 F





- Specifications ..... 14-2
  - ◇ General ..... 14-2
  - ◇ Receiver ..... 14-3
- Options ..... 14-4

## ■ Specifications

### ◇ General

- **Frequency coverage** (unit: MHz) :
  - USA : 0.005000–821.999999, 851.000000–866.999999  
896.000000–3335.000000
  - France : 0.050000–29.999999, 50.200000–51.200000,  
87.500000–108.000000, 144.000000–146.000000,  
430.000000–440.000000, 1240.000000–1300.000000
  - Europe, U.K., Canada, EXP, Australia : 0.005000–3335.000000
- **Operating mode** : USB, LSB, CW, FSK, AM, FM, WFM, P25
- **Number of memory channels** : 1220 (1000 regular channels, 100 auto memory write channels, 100 skip channels, 20 scan edge channels)
- **Antenna connector** : Type-N×2 (antenna impedance: 50  $\Omega$ ),  
SO-239×1 (antenna impedance: 50  $\Omega$ ),  
Phono (RCA)×1 (antenna impedance: 500  $\Omega$ )
- **Operating temperature range** : 0°C to +50°C; +32°F to +122°F
- **Frequency stability** : Less than  $\pm 0.05$  ppm (approx. 5 min. after from turn the main power, [I/O], ON, 0–50°C; 32–122°F)
- **Frequency resolution** : 1 Hz
- **Power supply requirement** : 100 V, 120 V, 230 V, 240 V AC
- **Power consumption** :
  - Receive : Less than 100 VA
  - Stand-by : Less than 100 VA
  - Max. audio
- **Dimensions** (projections not included) : 424×149×340 mm; 16<sup>1</sup>/<sub>16</sub>×57<sup>7</sup>/<sub>8</sub>×13<sup>3</sup>/<sub>8</sub> in
- **Weight** : Approx. 20 kg; 44 lb
- **ACC connector** : 8-pin DIN connector
- **DATA IN connector** : 8-pin DIN connector
- **Display\*** : 7-inch (diagonal) TFT color LCD (800×480)
- **EXT-DISPLAY connector** : D-sub 15S
- **RS-232C connector** : D-sub 9-pin
- **VIDEO IN connector** : Phono (RCA)
- **VIDEO OUT connector** : Phono (RCA)
- **SPEECH OUT connector** : Phono (RCA)
- **LINE OUT connector** : Phono (RCA)
- **USB connector** : USB (Universal Serial Bus)1.1/2.0
- **CI-V connector** : 2-conductor 3.5 (d) mm (<sup>1</sup>/<sub>8</sub>  $\epsilon$ )
- **ANT-SEL connector** : 3-conductor 3.5 (d) mm (<sup>1</sup>/<sub>8</sub>  $\epsilon$ )
- **DET OUT connector** : 3-conductor 3.5 (d) mm (<sup>1</sup>/<sub>8</sub>  $\epsilon$ )
- **EXT-SP connectors** : 2-conductor 3.5 (d) mm (<sup>1</sup>/<sub>8</sub>  $\epsilon$ )/8  $\Omega$
- **REC REMOTE connector** : 3-conductor 3.5 (d) mm (<sup>1</sup>/<sub>8</sub>  $\epsilon$ )×2  
(Front and rear panels)
- **REC OUT connector** : 3-conductor 3.5 (d) mm (<sup>1</sup>/<sub>8</sub>  $\epsilon$ )
- **PHONES connector** : 3-conductor 3.5 (d) mm (<sup>1</sup>/<sub>8</sub>  $\epsilon$ )

All stated specifications are typical and subject to change without notice or obligation.

## ◇ Receiver

- **Sensitivity** :
 

SSB, CW, FSK (BW (SSB, FSK)=2.4 kHz, (CW)=500 Hz, 10 dB S/N)	
0.100–1.799 MHz	0.5 $\mu$ V (pre-amp 1 ON)
1.800–29.999 MHz	0.2 $\mu$ V (pre-amp 1 ON)
30.000–2999.999 MHz	0.32 $\mu$ V (pre-amp ON)
3000.000–3335.000 MHz	1 $\mu$ V (pre-amp ON)
AM (BW=6 kHz, 10 dB S/N)	
0.100–1.799 MHz	6.3 $\mu$ V (pre-amp 1 ON)
1.800–29.999 MHz	2.5 $\mu$ V (pre-amp 1 ON)
30.000–2999.999 MHz	3.5 $\mu$ V (pre-amp ON)
3000.000–3335.000 MHz	11 $\mu$ V (pre-amp ON)
FM (BW=15 kHz, 12 dB SINAD)	
28.000–29.990 MHz	0.5 $\mu$ V (pre-amp 1 ON)
30.000–2999.999 MHz	0.5 $\mu$ V (pre-amp ON)
3000.000–3335.000 MHz	1.6 $\mu$ V (pre-amp ON)
FM50k (BW=50 kHz, 12 dB SINAD)	
28.000–29.990 MHz	0.71 $\mu$ V (pre-amp 1 ON)
30.000–2999.999 MHz	0.71 $\mu$ V (pre-amp ON)
3000.000–3335.000 MHz	2.2 $\mu$ V (pre-amp ON)
WFM (BW=180 kHz, 12 dB SINAD)	
30.000–2999.999 MHz	1.4 $\mu$ V (pre-amp ON)
3000.000–3335.000 MHz	4.5 $\mu$ V (pre-amp ON)
- **Internal modulation distortion (typical)** : Dynamic range 109 dB  
(at 14.100 MHz, 100 kHz separation, Pre-amp 1 OFF)
- **Selectivity** :
 

SSB, FSK (BW=2.4 kHz)	More than 2.4 kHz/–3 dB Less than 3.6 kHz/–60 dB
CW (BW=500 Hz)	More than 500 Hz/–3 dB Less than 700 Hz/–60 dB
AM (BW=6 kHz)	More than 6.0 kHz/–3 dB Less than 15.0 kHz/–60 dB
FM (BW=15 kHz)	More than 12.0 kHz/–6 dB Less than 25.0 kHz/–60 dB
WFM	More than 180.0 kHz/–6 dB
- **Spurious and image rejection response ratio** :
 

0.1.000–30.000 MHz	More than 70 dB
30.000–2500.000 MHz	More than 50 dB
2500.000–3000.000 MHz	More than 40 dB
- **Audio output power** : More than 2.6 W at 10% distortion with an 8  $\Omega$  load

\*The LCD display may have cosmetic imperfections that appear as small or dark spots. This is not a malfunction or defect, but a normal characteristic of LCD displays.

Spurious signals may be received near the following frequencies. These are made in the internal circuit and does not indicate a receiver malfunction.

- 114.110 kHz, • 229.280 kHz, • 8.636 MHz, • 10.749 MHz, • 66.671 MHz, • 119.259 MHz,
- 161.732 MHz, • 200.865 MHz, • 440.865 MHz, • 1226.749 MHz, • 1269.398 MHz, • 1317.398 MHz,
- 1410.649 MHz, • 1439.999 MHz, • 1599.999 MHz, • 1645.449 MHz, • 1674.799 MHz, • 1810.773 MHz,
- 1856.098 MHz, • 1875.665 MHz, • 2005.448 MHz, • 2154.798 MHz, • 2336.099 MHz, • 2394.798 MHz,
- 2512.199 MHz, • 2799.999 MHz, • 2842.848 MHz, • 2933.500 MHz, • 2999.999 MHz, • 3199.999 MHz,
- 3232.198 MHz, • 3261.548 MHz

Spurious waveforms may be displayed on the spectrum scope screen regardless of the receiver's condition. They are made in the scope circuit. This does not indicate a receiver malfunction.

### ■ Options

- **CT-17** CI-V LEVEL CONVERTER



For remote receivers control using a PC. You can change frequencies, operating mode, memory channels, etc. (software is not included)

- **SP-20** EXTERNAL SPEAKER



4 audio filters; headphone jack; can connect to 2 receivers.

- Input impedance : 8  $\Omega$
- Max. input power : 5 W

- General ..... 15-2
- Caution ..... 15-2
- Preparation ..... 15-3
  - ◇ Firmware and firm utility ..... 15-3
  - ◇ File downloading ..... 15-3
- Firmware update— USB-Memory ..... 15-4
- Firmware update— PC ..... 15-6
  - ◇ Connections ..... 15-6
  - ◇ IP address setting ..... 15-7
  - ◇ Updating from the PC ..... 15-8

## ■ General

At least one available USB (2.0 or 1.1) port is required to copy the downloaded firmware file. An Ethernet card/board (10 BASE-T/100 BASE TX compatible) is required when updating the firmware from the PC. The USB hub and Ethernet card/board are not supplied by Icom. Ask your PC dealer about a USB hub and an Ethernet card/board for details.

The IC-R9500's firmware can be updated if desired. By updating the firmware, new function(s) can be added and performance parameters improved.

2 methods of firmware update are available; one uses the USB-Memory, and the other uses a PC. You can choose either method according to your PC capabilities.

- When only one PC that is connected to the INTERNET is available
  - ➔ Refer to ■ Preparation (p. 15-3) and ■ Firmware update—USB-Memory (p. 15-4)
- When two or more PCs that are connected to the INTERNET are available and they are connected to a LAN (Local Area Network)
  - ➔ Refer to ■ Preparation (p. 15-3) and either ■ Firmware update—PC (p. 15-6) or ■ Firmware update—USB-Memory (p. 15-4)

Ask your dealer or distributor about how to update the firmware if you have no PC.

## ■ Caution

⚠ **CAUTION!** NEVER turn the receiver power OFF while updating the firmware.

You can turn the receiver power OFF only when the receiver display shows that rebooting is required.

If you turn the receiver power OFF, or if a power failure occurs during updating, the receiver firmware will be corrupted and you will have to send the receiver back to the nearest Icom distributor for repair. This type of repair is out of warranty even if the warranty period is still valid.

---

### ***Recommendation!***

Backing up the settings and/or memory contents to the CF card or USB-Memory before starting the firmware update is recommended.

Settings and/or memory contents will be lost or returned to default settings when the firmware update is performed.

---

## ■ Preparation

### ◇ Firmware and firm utility

The latest firmware and the firm utility can be downloaded from the Icom home page via the INTERNET. Access the following URL to download the firm utility and the latest firmware.

<http://www.icom.co.jp/world/download/index.htm>

#### **For updating from the USB-Memory**

When updating the firmware from the USB-Memory, copy the downloaded firmware data (e.g. 9500xxxx.dat) to the USB-Memory (in "IC-R9500" folder) using an available USB port (USB hub may be required; purchased separately from your PC dealer).

### ◇ File downloading

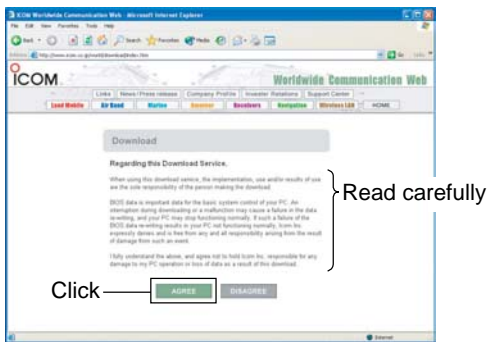

- ① Access the following URL directly.  
<http://www.icom.co.jp/world/download/index.htm>  
• No link is available from the top page.
- ② Read "Regarding this Download Service" carefully, then click [AGREE].
- ③ Click "IC-R9500" link then click the firmware file link.

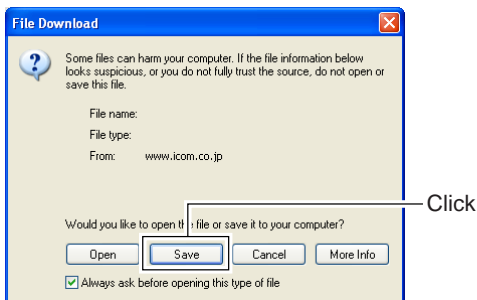

- ④ Click [Save] in the displayed File Download dialog.

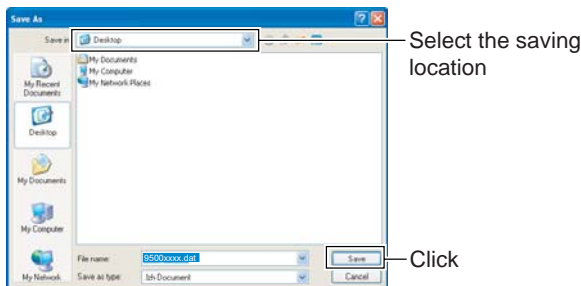

- ⑤ Select the desired location to which you want to save the firmware, then click [Save] in the displayed File Download dialog.  
• File download starts.
- ⑥ After download is completed, extract the file.  
• The firmware and the firm utility are compressed in "zip" format, respectively.  
• When updating the receiver using with the USB-Memory, copy the extracted firmware (e.g. 9500xxxx.dat) to the USB-Memory IC-R9500 folder.  
• The USB-Memory must have been formatted by the IC-R9500 (p. 11-23).

## Firmware update—USB-Memory

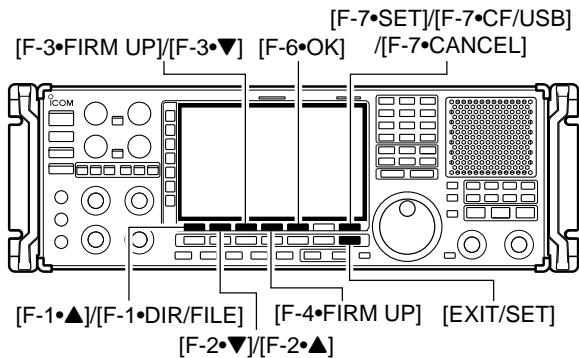

When updating the firmware with the CF card or USB-Memory, no IP address or subnet mask settings are necessary.

- ① Copy the downloaded firmware data into the USB-Memory ("IC-R9500" folder).
  - The USB-Memory must have been formatted by the IC-R9500.
- ② Insert the USB-Memory into the USB connector.
- ③ Push [EXIT/SET] several times to close a multi-function screen, if necessary.
- ④ Push [F-7•SET] to select set mode menu screen.
- ⑤ Push [F-7•CF/USB] to select CF/USB-Memory set menu.

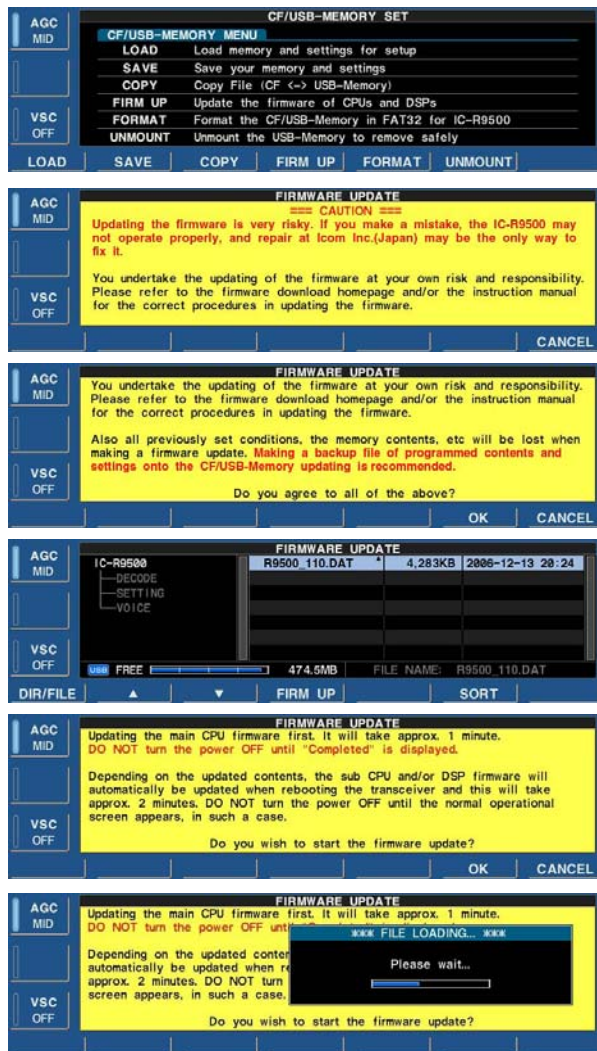

- ⑥ Push and hold [F-3•FIRM UP] for 1 sec.
- ⑦ Read the displayed precautions carefully.
  - Push [F-1•▲] or [F-2•▼] to scroll the text.
  - Push [F-7•CANCEL] to cancel firmware updating.
- ⑧ After you read and understand all of the precautions, push [F-6•OK].
  - [F-6•OK] appears only following the precautions.
  - Push [F-7•CANCEL] to cancel the firmware updating.
- ⑨ Push [F-2•▲] or [F-3•▼] to select the firmware file, then push [F-4•FIRM UP].
  - Push and hold [F-1•DIR/FILE] for 1 sec. to select the USB-Memory, if CF card is selected.
- ⑩ Read the displayed precautions carefully.
- ⑪ If you agree, push [F-6•OK] for 1 sec. to start the firmware update.
  - Push [F-7•CANCEL] to cancel firmware updating.
- ⑫ While loading the firmware from the CF memory card, the dialog at left is displayed.



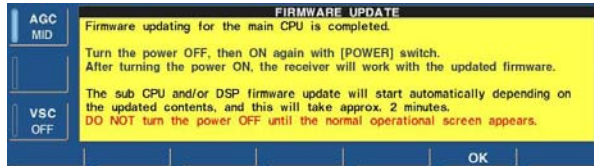

⑬ After firmware loading is completed, the receiver starts the update automatically and the dialog at left is displayed.

⚠ **WARNING!** NEVER turn the IC-R9500 power OFF at this stage.  
 The receiver firmware will be damaged.

⑭ When the dialog disappears, the precaution as at left is displayed.

⑮ Read the precaution carefully, and then push [F-6•OK].  
 • Return to CF/USB-Memory set menu.

⑯ Push [POWER] to turn the IC-R9500 power OFF, then ON again.

⑰ Depending on the status of the update process, either of dialogs at left will appear in sequence.

⚠ **WARNING!** NEVER turn the IC-R9500 power OFF at this stage.  
 The receiver firmware will be corrupted.

⑱ After the dialog disappears, the firmware update is completed and the normal operation screen appears.

## ■ Firmware update— PC

### ◇ Connections

Connect the IC-R9500 and the PC through a LAN (Local Area Network) as follows.

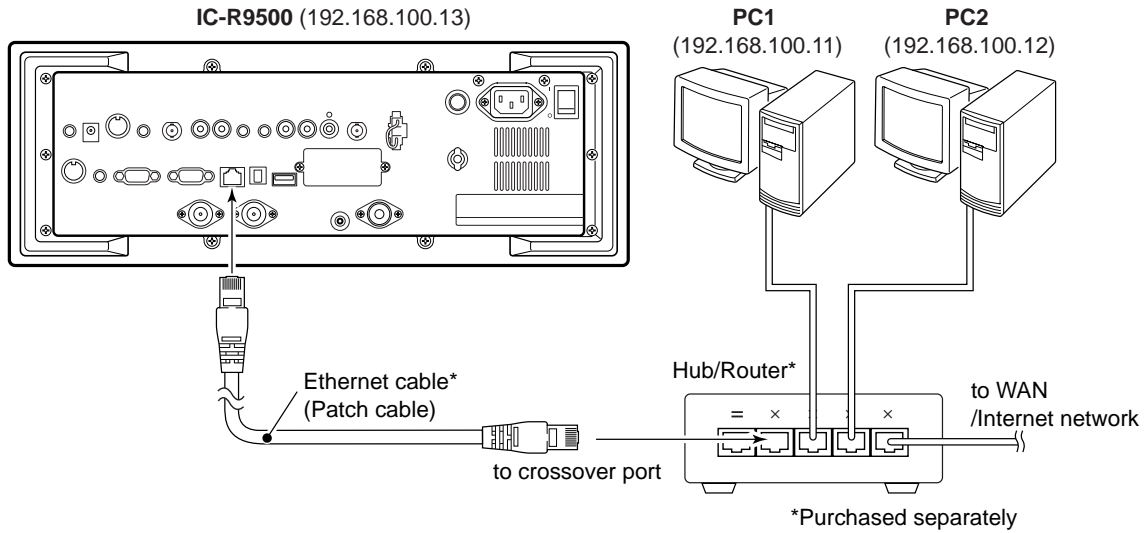

#### • IP address setting example

	PC1	PC2	IC-R9500
IP address	192.168.100.11	192.168.100.12	192.168.100.13
Subnet mask	255.255.255.0	255.255.255.0	255.255.255.0

◇ IP address setting

When updating the firmware from the USB-Memory, setting the IP address is not necessary.

**IMPORTANT!:** A fixed (static) IP address is used for the IC-R9500.

When you connect the IC-R9500 to a LAN, ask the network manager about a usable/assignable IP address and the subnet mask in advance.

**NEVER** use an IP address that has already been allocated to another device in the network. If the IP address is duplicated, the network will crash.

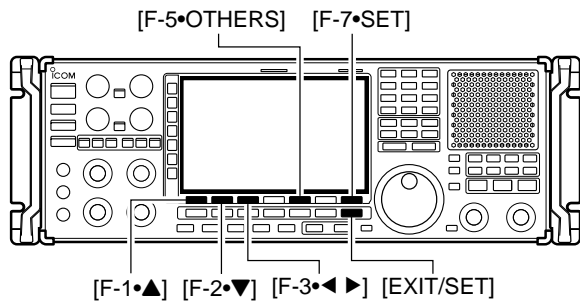

- ① Push [EXIT/SET] several times to close a multi-function screen, if necessary.
- ② Push [F-7•SET] to select set mode menu screen.
- ③ Push [F-5•OTHERS] to select the others set mode.



- ④ Push [F-1•▲]/[F-2•▼] several times to select “IP Address.”
- ⑤ Push [F-3•◀▶] to select the desired segment then rotate main dial to set the desired or specified IP address.



- “192.168.0.1” is the default setting.
- ⑥ Push [F-2•▼] to select “Subnet Mask” item.
  - ⑦ Rotate main dial to set the desired or specified subnet mask.
  - “255.255.255.0” is the default setting.
  - ⑧ Push [POWER] to turn the receiver power OFF, then ON to accept the new IP address and subnet mask settings.

◆ Updating from the PC



- ① Start up the IC-R9500 Firm Utility.
  - The window as at left appears.
- ② Read the caution in the window carefully.
- ③ Click [Yes] if you agree and to continue the firmware updating.

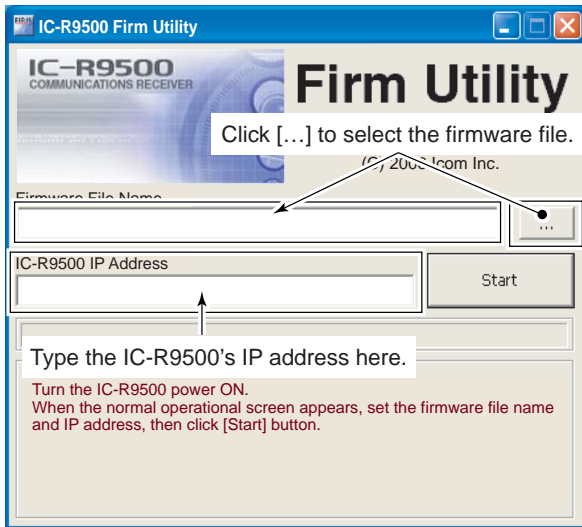

- ④ Select the firmware file with the "dat" extension (e.g.: 9500xxxx.dat).
  - Click [...], then select the file, as well as the location.
- ⑤ Type the IC-R9500's IP address into "IC-R9500 IP Address" text box.
- ⑥ Click [Start].

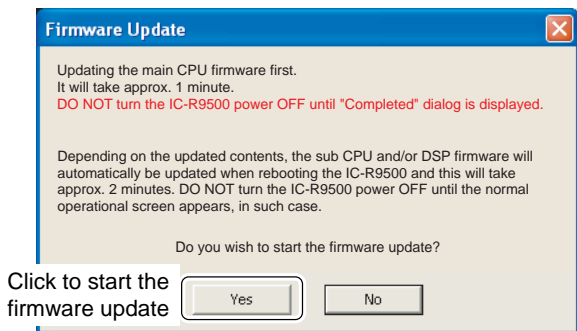

- ⑦ The window at left appears.
  - Read the precaution in the window carefully.
- ⑧ Click [Yes] if you want to start the firmware update.

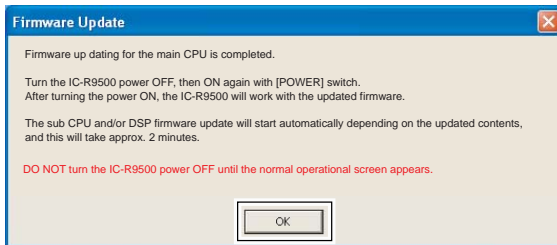
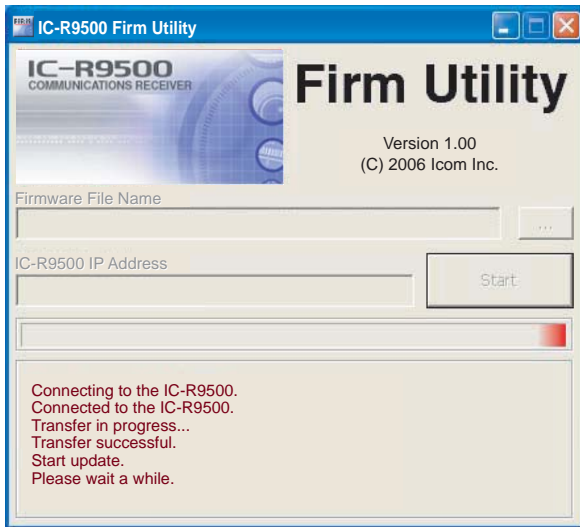

Click [OK] to finish the firmware update.



- ⑨ The screen at left is displayed.
  - The following dialog appears in the IC-R9500 display.

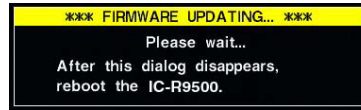

⚠ **WARNING!:** NEVER turn the IC-R9500 power OFF at this stage.  
 The receiver firmware will be corrupted.

- ⑩ Click [OK] to finish the firmware update.
  - The “FIRMWARE UPDATING” dialog as above disappears.
- ⑪ Push [POWER] to turn the IC-R9500 power OFF, then ON again.

- ⑫ Depending on the status of the update process, either of dialogs at left will appear in sequence.

⚠ **WARNING!:** NEVER turn the IC-R9500 power OFF at this stage.  
 The receiver firmware will be corrupted.

- ⑬ After the dialog disappears, the firmware update is completed and the normal operation screen appears.



We Icom Inc. Japan  
1-1-32, Kamiminami, Hirano-ku  
Osaka 547-0003, Japan

Declare on our sole responsibility that this equipment complies with the essential requirements of the Radio and Telecommunications Terminal Equipment Directive, 1999/5/EC, and that any applicable Essential Test Suite measurements have been performed.

**Kind of equipment:** COMMUNICATIONS RECEIVER

**Type-designation:** IC-R9500

**Version (where applicable):** \_\_\_\_\_

This compliance is based on conformity with the following harmonised standards, specifications or documents:

- i) Article 3.1a EN 60950-1 (2001):A11:2004
- ii) Article 3.1b EN 301489-1 and EN 301489-15
- iii) Article 3.2 EN 301 783-2

## DECLARATION OF CONFORMITY



D sseldorf 13th Jan.2007  
Place and date of issue

Icom (Europe) GmbH  
Himmelgeister straÙe 100  
D-40225 D sseldorf

Authorized representative name  
H. Ikegami  
General Manager

Signature

**Icom Inc.**

Please record the serial number of your IC-R9500 receiver below for future servicing reference:

**Serial Number** :

---

**Date of purchase** :

---

**Place where purchased** :

---

## Count on us!

IC-R9500  
#03 (France)

<Intended Country of Use>	
<input type="checkbox"/> GER	<input checked="" type="checkbox"/> FRA
<input type="checkbox"/> ESP	<input type="checkbox"/> SWE
<input type="checkbox"/> AUT	<input type="checkbox"/> NED
<input type="checkbox"/> POR	<input type="checkbox"/> DEN
<input type="checkbox"/> GBR	<input type="checkbox"/> BEL
<input type="checkbox"/> ITA	<input type="checkbox"/> FIN
<input type="checkbox"/> IRL	<input type="checkbox"/> LUX
<input type="checkbox"/> GRE	<input type="checkbox"/> SUI
<input type="checkbox"/> NOR	

IC-R9500  
#04 (Europe)

<Intended Country of Use>	
<input checked="" type="checkbox"/> GER	<input type="checkbox"/> FRA
<input checked="" type="checkbox"/> ESP	<input checked="" type="checkbox"/> SWE
<input checked="" type="checkbox"/> AUT	<input checked="" type="checkbox"/> NED
<input checked="" type="checkbox"/> POR	<input checked="" type="checkbox"/> DEN
<input type="checkbox"/> GBR	<input checked="" type="checkbox"/> BEL
<input checked="" type="checkbox"/> ITA	<input checked="" type="checkbox"/> FIN
<input checked="" type="checkbox"/> IRL	<input checked="" type="checkbox"/> LUX
<input checked="" type="checkbox"/> GRE	<input checked="" type="checkbox"/> SUI
<input checked="" type="checkbox"/> NOR	

IC-R9500  
#05 (United  
Kingdom)

<Intended Country of Use>	
<input type="checkbox"/> GER	<input type="checkbox"/> FRA
<input type="checkbox"/> ESP	<input type="checkbox"/> SWE
<input type="checkbox"/> AUT	<input type="checkbox"/> NED
<input type="checkbox"/> POR	<input type="checkbox"/> DEN
<input checked="" type="checkbox"/> GBR	<input type="checkbox"/> BEL
<input type="checkbox"/> ITA	<input type="checkbox"/> FIN
<input type="checkbox"/> IRL	<input type="checkbox"/> LUX
<input type="checkbox"/> GRE	<input type="checkbox"/> SUI
<input type="checkbox"/> NOR	