



## INSTRUCTION MANUAL

VHF/UHF DUALBAND FM TRANSCEIVER

# IC-P7A

This device complies with Part 15 of the FCC rules. Operation is subject to the following two conditions: (1) This device may not cause harmful interference, and (2) this device must accept any interference received, including interference that may cause undesired operation.

**WARNING:** MODIFICATION OF THIS DEVICE TO RECEIVE CELLULAR RADIO TELEPHONE SERVICE SIGNALS IS PROHIBITED UNDER FCC RULES AND FEDERAL LAW.

Icom Inc.



---

## FOREWORD

---

Thank you for purchasing this Icom product. The IC-P7A VHF/UHF DUALBAND FM TRANSCEIVER is designed and built with Icom's superior technology and craftsmanship. With proper care, this product should provide you with years of trouble-free operation.

We want to take a couple of moments of your time to thank you for making your IC-P7A your radio of choice, and hope you agree with Icom's philosophy of "technology first." Many hours of research and development went into the design of your IC-P7A.

### ◆ FEATURES

- *Covers the 0.495–999.990 MHz\* frequency range*  
\*Some frequency bands are disabled according to version
- *CTCSS and DTCS encoder/decoder standard*
- *1250 memory channels\* with 18 banks available*  
\*200 auto write and 50 scan edge channels are included.
- *1800 mAh large capacity Li-Ion battery standard*

---

## IMPORTANT

---

**READ ALL INSTRUCTIONS** carefully and completely before using the transceiver.

**SAVE THIS INSTRUCTION MANUAL**— This instruction manual contains important operating instructions for the IC-P7A.

---

## EXPLICIT DEFINITIONS

---

WORD	DEFINITION
⚠ <b>WARNING!</b>	Personal injury, fire hazard or electric shock may occur.
<b>CAUTION</b>	Equipment damage may occur.
<b>NOTE</b>	Recommended for optimum use. No risk of personal injury, fire or electric shock.

Icom, Icom Inc. and the ICOM logo are registered trademarks of Icom Incorporated (Japan) in the United States, the United Kingdom, Germany, France, Spain, Russia and/or other countries.

---

## PRECAUTION

---

**⚠ WARNING RF EXPOSURE!** This device emits Radio Frequency (RF) energy. Caution should be observed when operating this device. If you have any questions regarding RF exposure and safety standards please refer to the Federal Communications Commission Office of Engineering and Technology's report on Evaluating Compliance with FCC Guidelines for Human Radio Frequency Electromagnetic Fields (OET Bulletin 65)

**⚠ WARNING! NEVER** hold the transceiver so that the antenna is very close to, or touching exposed parts of the body, especially the face or eyes, while transmitting. The transceiver will perform best if the microphone is 5 to 10 cm (2 to 4 inches) away from the lips and the transceiver is vertical.

**⚠ WARNING! NEVER** operate the transceiver with a earphone, headphones or other audio accessories at high volume levels. Hearing experts advise against continuous high volume operation. If you experience a ringing in your ears, reduce the volume level or discontinue use.

**⚠ WARNING! NEVER** operate the transceiver while driving a vehicle. Safe driving requires your full attention—anything less may result in an accident.

**NEVER** expose the transceiver to rain, snow or any liquids. The transceiver may be damaged.

**NEVER** operate or touch the transceiver with wet hands. This may result in an electric shock or damage the transceiver.

**DO NOT** push the PTT when not actually desiring to transmit.

**AVOID** using or placing the transceiver in direct sunlight or in areas with temperatures below  $-10^{\circ}\text{C}$  ( $+14^{\circ}\text{F}$ ) or above  $+60^{\circ}\text{C}$  ( $+140^{\circ}\text{F}$ ).

Place the unit in a secure place to avoid inadvertent use by children.

**AVOID** the use of chemical agents such as benzine or alcohol when cleaning, as they can damage the transceiver's surfaces.

***For U.S.A. only***

**CAUTION:** Changes or modifications to this device, not expressly approved by Icom Inc., could void your authority to operate this device under FCC regulations.

## SUPPLIED ACCESSORIES

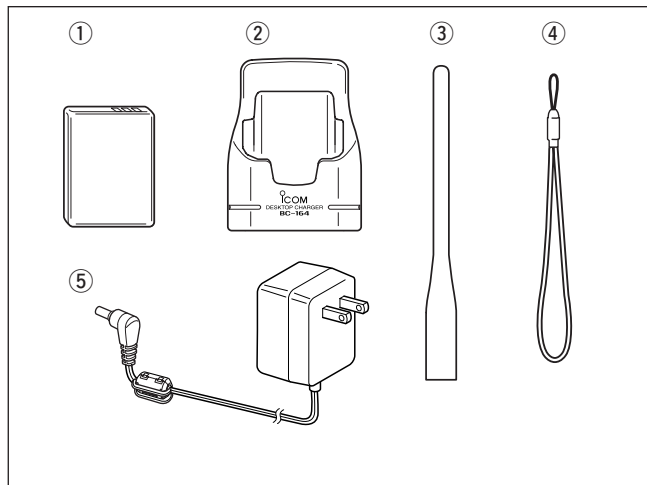

- ① Battery pack (BP-243) ..... 1
  - ② Battery charger (BC-164) ..... 1
  - ③ Antenna ..... 1
  - ④ Handstrap ..... 1
  - ⑤ AC adapter\* (BC-145LA/LE/LV) ..... 1
- (The shape of the BC-145LA, BC-145LE and BC-145LV are different.)

\*Depending on versions. Not supplied with some versions.

## TABLE OF CONTENTS

FOREWORD .....	i
IMPORTANT .....	i
EXPLICIT DEFINITIONS .....	i
PRECAUTION .....	ii
SUPPLIED ACCESSORIES .....	iii
TABLE OF CONTENTS .....	iii
<b>QUICK REFERENCE GUIDE .....</b>	<b>I-VIII</b>
■ Preparation .....	I
■ Your first contact.....	III
■ Repeater operation .....	V
■ Memory programming.....	VI
■ Programmed scan operation.....	VII
<b>1 PANEL DESCRIPTION .....</b>	<b>1-4</b>
■ Front, top and side panels .....	1
■ Function display .....	3
<b>2 BATTERY CHARGING .....</b>	<b>5-8</b>
■ Caution .....	5
■ Battery installation .....	7
■ Battery charging .....	8
<b>3 FREQUENCY AND CHANNEL SETTING .....</b>	<b>9-12</b>
■ VFO and memory channels.....	9
■ Operating band selection .....	9
■ Setting a frequency.....	11
■ Setting a tuning step.....	11
■ Selecting a memory channel.....	12
■ Selecting a call channel.....	12
<b>4 BASIC OPERATION .....</b>	<b>13-18</b>
■ Receiving.....	13
■ Setting audio volume.....	13
■ Squelch level setting .....	14
■ Operating mode selection .....	14
■ Monitor function.....	15
■ Attenuator function .....	15

■ Transmitting.....	16	■ Priority watch types .....	42
■ Transmit power selection .....	16	■ Priority watch operation.....	43
■ Dial select step.....	17	<b>9 TONE SQUELCH AND POCKET BEEP .....</b>	<b>45–48</b>
■ Lock function .....	18	■ Tone/DTCS squelch operation .....	45
■ [DIAL] function assignment .....	18	■ Tone squelch frequency/DTCS code setting .....	46
<b>5 REPEATER OPERATION.....</b>	<b>19–23</b>	■ DTCS polarity setting .....	47
■ General.....	19	■ Tone scan .....	48
■ Offset frequency .....	20	<b>10 SET MODE .....</b>	<b>49–59</b>
■ Subaudible tones.....	21	■ General.....	49
■ 1750 Hz tone .....	22	■ Set mode items .....	50
■ Auto repeater function .....	23	<b>11 OTHER FUNCTIONS .....</b>	<b>60–64</b>
<b>6 MEMORY/CALL CHANNELS .....</b>	<b>24–33</b>	■ Weather channel operation .....	60
■ General description .....	24	■ Data cloning .....	61
■ Memory channel programming.....	24	■ Auto power-off function .....	63
■ Memory bank setting .....	25	■ TV channel operation .....	63
■ Memory bank selection .....	26	■ Partial reset .....	64
■ Programming memory/bank name .....	27	■ All reset .....	64
■ Selecting display type.....	28	<b>12 FREQUENCY TABLE .....</b>	<b>65–72</b>
■ Copying memory contents.....	29	■ TV channels .....	65
■ Memory clearing.....	30	■ VHF marine channels.....	68
■ Transferring memory contents .....	31	■ Weather channels .....	68
■ Erasing/transferring bank contents.....	32	■ Other communications in the USA .....	69
■ Call channel programming .....	33	■ Other communications—other countries .....	71
■ Copying call channel contents.....	33	<b>13 MAINTENANCE .....</b>	<b>73–74</b>
<b>7 SCAN OPERATION .....</b>	<b>34–41</b>	■ Troubleshooting.....	73
■ Scan types.....	34	■ Optional CP-21LR fuse replacement.....	74
■ Full/band/programmed scan.....	35	<b>14 SPECIFICATIONS .....</b>	<b>75–76</b>
■ Scan edges programming .....	36	■ Transceiver .....	75
■ Memory/bank scan .....	37	■ Battery pack (BP-243) .....	76
■ Auto memory write scan .....	38	■ Battery charger (BC-164) .....	76
■ Skip channel/frequency setting .....	39	<b>15 OPTIONS .....</b>	<b>77–79</b>
■ Scan resume condition.....	41	■ Options .....	77
<b>8 PRIORITY WATCH .....</b>	<b>42–44</b>	<b>16 POCKET GUIDE .....</b>	<b>80–81</b>

# QUICK REFERENCE GUIDE

## ■ Preparation

### ◇ Battery installation

- ① Remove the battery cover from the transceiver.
- ② Install the BP-243 (Li-Ion battery pack).
  - Be sure to observe the correct polarity.
- ③ Replace the battery cover to the transceiver.

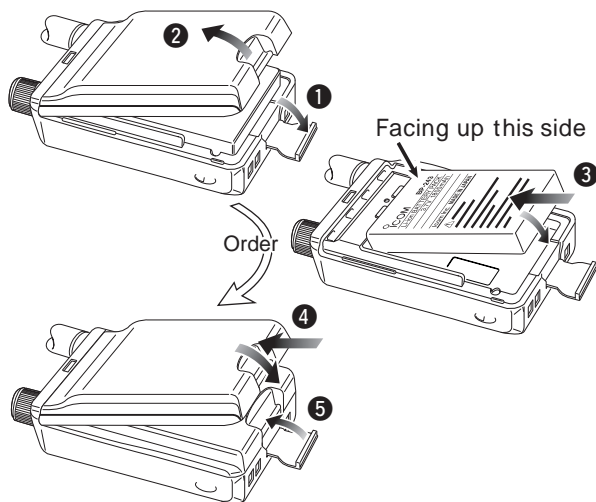

Keep the battery contacts clean. It's a good idea to clean the battery terminals once a week.

### ◇ Antenna

Insert the supplied antenna into the antenna connector and screw down the antenna as shown at right.

**NEVER** hold the antenna when carrying the transceiver.

**Keep** the jack cover attached when jack is not in use to protect the connector from dust and moisture.

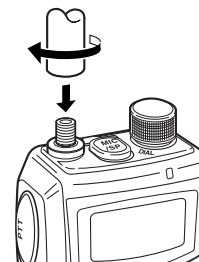

### ✓ For your information

Third-party antennas may increase transceiver performance. An optional AD-92SMA ANTENNA CONNECTOR ADAPTER is available to connect an antenna with a BNC connector.

### ◇ Handstrap

Slide the handstrap through the loop on the top of the rear panel as illustrated at right. Facilities carrying.

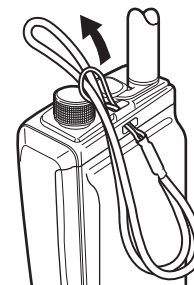

◇ Charging the battery

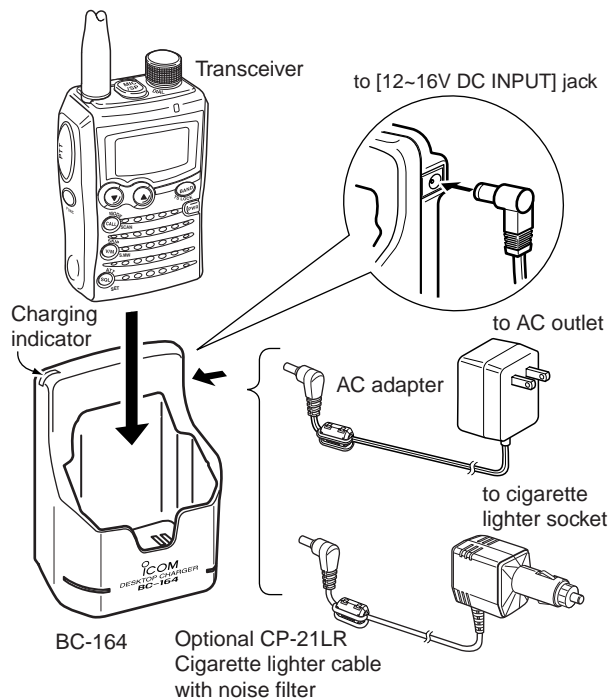



◇ Charging description

- ① Plug the AC adapter into an AC outlet; or the optional CP-21LR into a cigarette lighter socket.
- ② Insert the adapter plug into [12-16V DC INPUT] of the BC-164 BATTERY CHARGER.
- ③ Install the BP-243 BATTERY PACK (See left page) to the transceiver
- ④ Be sure to turn OFF the transceiver, then charge the battery with transceiver.
  - Takes approximately 3 hours for fully charge with the supplied BP-243 battery pack.
  - Charging indicator of BC-164 lights or blinks as follows.

Charging indicator status	Charging status
Lights orange	Charging
Lights green	Charging is completed
Blinking red	Charging error*

\* It may be charging outside of the specified temperature range: +5°C to +35°C (+41°F to +95°F). Restore the specified temperature range and reinsert the transceiver.

NOTE: The transceiver has battery indicator to show the following information.

- No indicator appears when the installed battery pack has ample capacity.
-  (battery indicator) appears when the battery pack is nearing exhaustion.
-  blinks when the battery pack must be charged.
-  and "LOW" indicator appear just before the battery pack is completely discharged and display turns OFF.

⚠ **WARNING!:**  
**NEVER** charge any other than the specified battery pack.

## QUICK REFERENCE GUIDE

### ■ Your first contact

Now that you have your IC-P7A ready, you are probably excited to get on the air. We would like to take you through a few basic steps to make your first experience “On The Air” enjoyable.

#### ◇ About default settings

The **[DIAL]** control function can be exchanged with the **[▲]/[▼]** key functions by pushing and holding **[FUNC]** then push **[▲]** or **[▼]**. However, in this QUICK REFERENCE GUIDE, the factory default setting (**[DIAL]** sets operating frequency) is used to simplify the instructions.

#### ◇ Basic operation

##### 1. Turning ON the transceiver

- Push and hold **[PWR]** for 1 sec. to turn the power ON.
  - Opening indication passes through, then frequency indication appears.

▨ The opening indication can be skipped. While pushing and holding **[FUNC]**, push and hold **[PWR]** for 1 sec. to shortcut the opening indication.

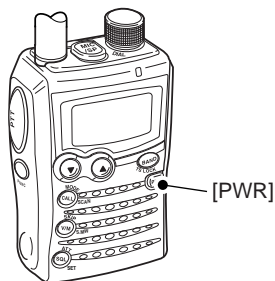

##### 2. Adjusting audio level

- Push **[▲]/[▼]** to set the desired audio level.

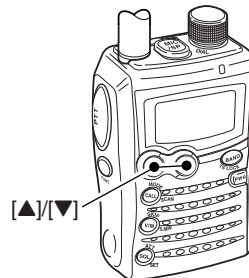

##### 3. Adjusting squelch level

- While pushing and holding **[SQL]** (**ATT•SET**), rotate **[DIAL]** to set the squelch level.

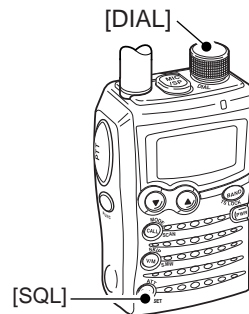



#### 4. Tune the desired frequency

The tuning dial will allow you to dial in the frequency you want to use. Pages 11 and 17 will instruct you on how to set the tuning step size.

- ① Push **[BAND] (TS•LOCK)** several times to select the desired frequency band.
  - While pushing and holding **[BAND] (TS•LOCK)**, rotating **[DIAL]** also selects frequency band.
- ② Rotate **[DIAL]** to set the desired frequency.
  - While pushing and holding **[FUNC]**, rotate **[DIAL]** to select frequency in 1 MHz steps.

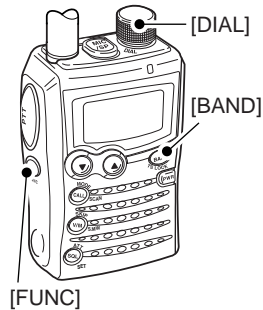

#### 5. Operating mode selection

- ➔ While pushing and holding **[FUNC]**, push **[CALL] (MODE•SCAN)** several times to select the desired operating mode.
  - FM, WFM and AM modes are selectable.

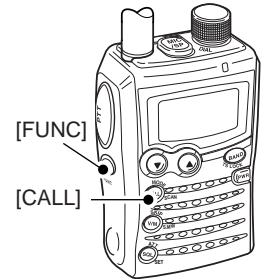

#### 6. Transmit and receive

- ➔ Push and hold **[PTT]** to transmit then speak into the microphone; release to receive.
  - Transmission is available on the 144 MHz/440 MHz (FM mode) amateur bands only.

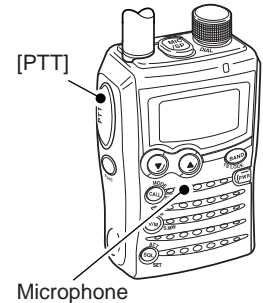

## ■ Repeater operation

### 1. Setting duplex

- ① While pushing and holding **[FUNC]**, push and hold **[SQL]** (**ATT•SET**) for 1 sec. to enter *set mode*.
- ② Rotate **[DIAL]** to select "DUP."
- ③ While pushing and holding **[FUNC]**, rotate **[DIAL]** to select minus duplex or plus duplex.
  - The USA/KOREA versions have an auto repeater function, therefore setting duplex is not required.

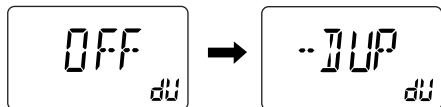
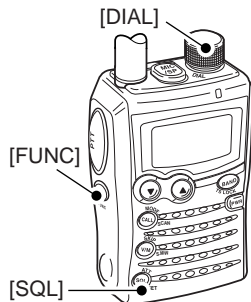

- ④ Push **[SQL]** (**ATT•SET**) to exit *set mode*.



### 2. Repeater tone

- ① While pushing and holding **[FUNC]**, push and hold **[SQL]** (**ATT•SET**) for 1 sec. to enter *set mode*.
- ② Rotate **[DIAL]** to select "T/TSQL."
- ③ While pushing and holding **[FUNC]**, rotate **[DIAL]** to select the repeater tone activation.

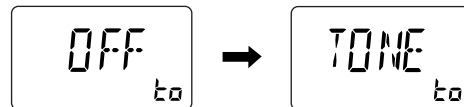
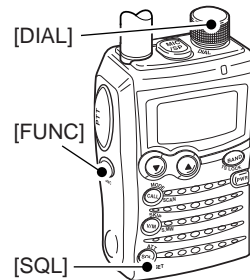

- ④ Push **[SQL]** (**ATT•SET**) to exit *set mode*.



## ■ Memory programming

The IC-P7A has a total of 1250 memory channels (including 200 auto write channels and 50 scan edges) for storing often used operating frequency, mode, etc.

### 1. Setting frequency

In *VFO mode*, set the desired receive frequency mode.

- When “**MR**” indicator is displayed, push **[V/M]** (**SKIP•S.MW**) to select the *VFO mode*.

### 2. Selecting a memory channel

Push **[V/M]** (**SKIP•S.MW**) for 1 sec. to enter *select memory write mode* (1 short and 1 long beep sound), then rotate **[DIAL]** to select the desired memory channel.

- “**MR**” indicator and memory channel number blink.

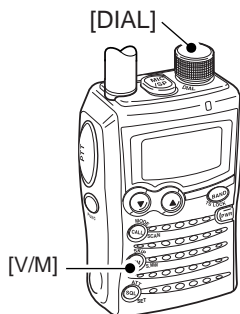
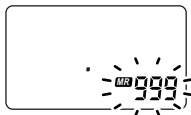

- To cancel and exit *select memory write mode*, push **[V/M]** (**SKIP•S.MW**) momentarily.

### 3. Writing a memory channel

Push and hold **[V/M]** (**SKIP•S.MW**) for 1 sec. until 3 beeps sound.

- Memory channel number automatically increases when continuing to push **[V/M]** (**SKIP•S.MW**) after programming.

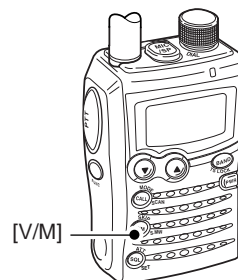

### ■ Programmed scan operation

50 channels of memories in 25 pairs are used to specify scanning ranges for programmed scan operation. The programmed scan scans between “xxA” and “xxb” (xx=00 to 24) channels. Therefore, before operating the programmed scan, different frequencies must be programmed into the “A” and “b” channels.

#### ◇ Programming scan edges

A start and stop frequency must be programmed into a pair of “xxA” or “xxb” channels.

#### 1. Setting frequency

In *VFO mode*, set the desired operating frequency and mode.

- When “**MR**” indicator is displayed, push **[V/M] (SKIP•S.MW)** to select the *VFO mode*.

#### 2. Selecting a scan edge channel “A”

Push and hold **[V/M] (SKIP•S.MW)** for 1 sec. to enter *select memory write mode* (1 short and 1 long beep sound), then rotate **[DIAL]** to select the desired scan edge channel “A.”

- “**MR**” indicator and scan edge channel number blink.



#### 3. Writing a memory channel

Push and hold **[V/M] (SKIP•S.MW)** for 1 sec. until 3 beeps sound.

- Scan edge channel “b” is automatically selected when continuing to push **[V/M] (SKIP•S.MW)** after programming.
- After programming is completed, the display returns to *VFO indication*.

#### 4. Selecting a scan edge channel “b”

Push and hold **[V/M] (SKIP•S.MW)** for 1 sec., then rotate **[DIAL]** to select the desired scan edge channel “b.”

- “**MR**” indicator and scan edge channel number blink.
- When the scan edge channel “b” is already selected at step 3, continuing to push **[V/M] (SKIP•S.MW)** after programming, skip this step.



#### 5. Writing a memory channel

Push and hold **[V/M] (SKIP•S.MW)** for 1 sec. until 3 beeps sound.

- The next scan edge channel “A” is automatically selected when continuing to push **[V/M] (SKIP•S.MW)** after programming.
- After programming is completed, the display returns to *VFO indication*.

◆ Starting scan

1. Select **VFO mode**.

Push **[V/M]** (**SKIP•S.MW**) to select the *VFO mode* for full, band and programmed scan operation.

- Select *memory mode* by pushing **[V/M]** (**SKIP•S.MW**) again for memory or bank scan.

2. Selecting a scanning type

Push and hold **[CALL]** (**MODE•SCAN**) for 1 sec., then rotate **[DIAL]** to select the desired scanning type.

- Available scan types when *VFO mode* is selected; “ALL” for full scan; “BAND” for the selected band; one of “PROGxx” (xx=0 to 24) for programmed scan.
- Available scan types when *memory mode* is selected; “M ALL” for all memory scan “B ALL” for all bank scan, “B LINK” for bank link scan, “BANK” for the selected bank scan.

• Scan type indication examples

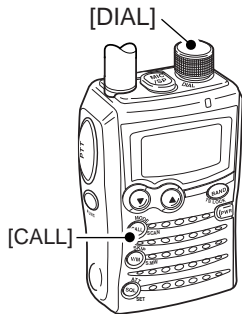

- Full scan
- Band scan
- Programmed scan

3. Starting scan

Push **[CALL]** (**MODE•SCAN**) to start the scan.

- Rotate **[DIAL]** to change the scanning direction.

• Full/Band scan

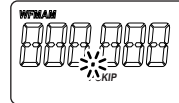

• Programmed scan



• All memory/All bank/  
Bank link scan

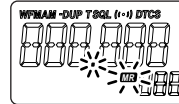

• Bank scan

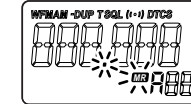

4. Cancelling scan

Push **[CALL]** (**MODE•SCAN**) again to stop scan.

✓ For your information

The memory channel number you program the scan edges into correlate “PROGxx” as follows:

00A/00b: Select “PROG 00” to scan between frequencies programmed in 00A and 00b channels.

01A/01b: Select “PROG 01” to scan between frequencies programmed in 01A and 01b channels.

⋮

24A/24b: Select “PROG 24” to scan between frequencies programmed in 24A and 24b channels.

# 1 PANEL DESCRIPTION

## ■ Front, top and side panels

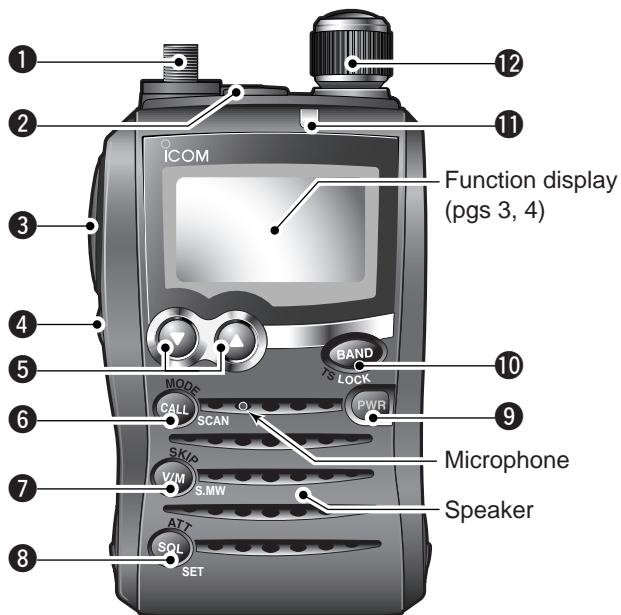

### ❶ ANTENNA CONNECTOR (p. 1)

Connects to the supplied antenna.

- An optional AD-92SMA adapter (p. 77) is available for connecting an antenna with a BNC connector.

### ❷ EXTERNAL SPEAKER/MICROPHONE JACK [MIC/SP]

Connect an optional speaker-microphone or headset via an optional OPC-782 PLUG ADAPTOR CABLE, if desired.

The internal microphone and speaker will not function when the OPC-782 is connected. (See p. 77 for a list of available options.)

### ❸ PTT SWITCH [PTT] (p. 16)

➔ Push and hold to transmit, release to receive.

- ➔ While pushing and holding [FUNC], push to toggle the transmit output power between High and Low.

### ❹ FUNCTION KEY [FUNC]

Push and hold this key for access to secondary functions.

### ❺ UP/DOWN KEYS [▲]/[▼]

➔ Adjusts audio volume level.\* (p. 13)

- ➔ While pushing and holding [FUNC], push either key to exchange [DIAL] and [▲]/[▼] function. (p. 18)

\*The function of [DIAL] and [▲]/[▼] can be exchanged. See page 18 for details.

**6 CALL•MODE•SCAN KEY [CALL] (MODE•SCAN)**

- Push momentarily to select the call channel. (p. 12)
- Push and hold for 1 sec. to enter the scan type selection condition, push again to start a scan. (p. 35)
- While pushing and holding [FUNC], push momentarily to select the operating mode. (p. 14)
- While pushing and holding [FUNC], push and hold for 1 sec. to start a tone scan. (p. 48)

**7 VFO/MEMORY•MEMORY WRITE KEY [V/M] (SKIP•S.MW)**

- Push momentarily to toggle between VFO and *memory mode*. (p. 9)
- Push and hold for 1 sec. to enter *select memory write mode*. (p. 24)
- While pushing and holding [FUNC], push momentarily to select scan skip condition. (p. 40)
- During VFO scan, pushing and holding [FUNC], push and hold for 1 sec. to store into highest blank memory channel as PSKIP channel (p. 40)

**8 SQUELCH•ATTENUATOR•SET KEY [SQL] (ATT•SET)**

- Push and hold to open the squelch temporarily and monitor the operating frequency. (p. 15)
- While pushing and holding this key, rotate [DIAL]\* to adjust the squelch level. (p. 14)
- While pushing and holding [FUNC], push and hold for 1 sec. to enter *set mode*. (p. 49)

**9 POWER KEY [PWR]**

Push and hold for 1 sec. to turn the transceiver power ON and OFF.

**10 BAND•TUNING STEP•LOCK KEY [BAND] (TS•LOCK)**

- Push to select the operating frequency band. (p. 9)
- While pushing and holding [FUNC], push momentarily to enter *tuning step set mode*. (p. 11)
- While pushing and holding [FUNC], push and hold for 1 sec. to toggle the lock function ON and OFF. (p. 18)

**11 TX RX INDICATOR [TX/RX] (pgs. 13, 16)**

Lights green while receiving a signal or when the squelch is open; lights red while transmitting.

**12 CONTROL DIAL [DIAL]**

- Rotate to select the operating frequency.\* (p. 11)
- While scanning, changes the scanning direction.\* (p. 35)
- While pushing and holding [SQL] (ATT•SET), sets the squelch level.\* (p. 14)
- While pushing and holding [FUNC], changes the operating frequency in 100 kHz, 1 MHz or 10 MHz increments in *VFO mode*.\* (p. 11)
- While pushing and holding [FUNC], changes the memory channel in 10 channels steps in *memory mode*.\* (p. 12)
- While pushing and holding [BAND] (TS•LOCK), selects the operating band in *VFO mode*.\* (p. 9)
- While pushing and holding [BAND] (TS•LOCK), selects the programmed bank or auto memory write channel in *memory mode*.\* (p. 9)

# 1 PANEL DESCRIPTION

## ■ Function display

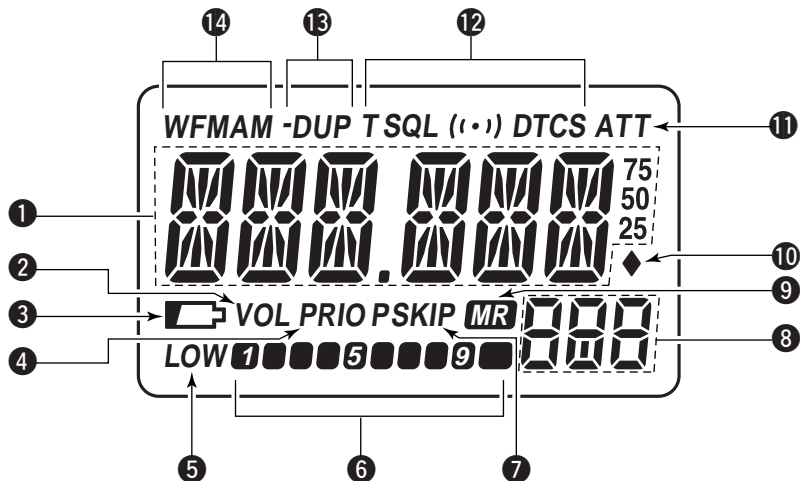

### ① FREQUENCY READOUT



Displays a variety of information, such as an operating frequency, set mode contents, memory names.

- The smaller “75,” “50” and “25” on the right of the readout indicate 0.75, 0.5 and 0.25 kHz, respectively.
- The decimal point blinks during scan.

### ② DIAL/VOLUME EXCHANGE INDICATOR (p. 18)

Appears when the function of [DIAL] and [▲]/[▼] are exchanged.

### ③ BATTERY INDICATOR

- ➔ No indicator appears when the installed battery pack has ample capacity.
- ➔ “” (battery indicator) appears when the battery pack is nearing exhaustion.
- ➔ “” blinks when the battery pack must be charged.
- ➔ “” and “LOW” indicator appear just before the battery pack is completely discharged and display turns OFF.



**4 PRIORITY WATCH INDICATOR** (p. 43)

Appears when priority watch is in use.

**5 LOW POWER INDICATOR** (p. 16)

- “LOW” appears when the low output power is selected.
- No indicator appears when the high output power is selected.

**6 S/RF METER**

- Shows the relative signal strength while receiving signals. (p. 13)
- Shows the output power level while transmitting. (p. 16)

**7 SKIP INDICATORS** (p. 39)

- “SKIP” appears when the selected memory channel is set as a skip channel.
- “PSKIP” appears when the displayed frequency is set as a skip frequency.

**8 MEMORY CHANNEL NUMBER INDICATOR**

- Shows the selected memory channel number. (pgs. 12, 24)
- “C” appears when the call channel is selected. (p. 12)
- “L” appears when the lock function is active. (p. 18)

**9 MEMORY INDICATOR** (pgs. 12, 24)

Appears when *memory mode* is selected.

**10 AUTO WRITE CHANNEL INDICATOR** (p. 38)

Appears when auto write channel is selected.

**11 ATTENUATOR INDICATOR** (p. 15)

Appears when the RF attenuator is in use.

**12 TONE INDICATORS**

- “T” appears while the subaudible tone encoder is in use. (p. 21)
- “T SQL” appears while the tone squelch function is in use. (p. 45)
- “DTCS” appears while the DTCS squelch function is in use. (p. 45)
- “((•))” appears with the “T SQL” or “DTCS” indicator while the pocket beep function (with CTCSS or DTCS) is in use. (p. 45)

**13 DUPLEX INDICATORS** (p. 19)

“DUP” appears when plus duplex, “-DUP” appears when minus duplex (repeater operation) is selected.

**14 OPERATING MODE INDICATOR** (p. 14)

Shows the selected operating mode.  
• FM, WFM and AM are available.

## ■ Caution

Misuse of LiTHIUM-ion batteries may result in the following hazards: smoke, fire, or the the battery may rupture. Misuse can also cause damage to the battery or degradation of battery performance.

- ⚠ **DANGER!** Use and charge only specified Icom battery packs with Icom radios. Only Icom battery packs are tested and approved for use with Icom radios. Using third-party or counterfeit battery packs may cause smoke, fire, or cause the battery to burst.

### ◇ Battery caution

- ⚠ **DANGER! DO NOT** hammer or otherwise impact the battery. Do not use the battery if it has been severely impacted or dropped, or if the battery has been subjected to heavy pressure. Battery damage may not be visible on the outside of the case. Even if the surface of the battery does not show cracks or any other damage, the cells inside the battery may rupture or catch fire.
  - ⚠ **DANGER! NEVER** use or leave battery pack in areas with temperatures above +60°C (+140°F). High temperature buildup in the battery, such as could occur near fires or stoves, inside a sun heated car, or in direct sunlight may cause the battery to rupture or catch fire. Excessive temperatures may also degrade battery performance or shorten battery life.
- ⚠ **DANGER! DO NOT** expose the battery to rain, snow, seawater, or any other liquids. Do not charge or use a wet battery. If the battery gets wet, be sure to wipe it dry before using. The battery by itself is not waterproof.
  - ⚠ **DANGER! NEVER** incinerate used battery pack since internal battery gas may cause it to rupture, or may cause an explosion.
  - ⚠ **DANGER! NEVER** solder the battery terminals. This may cause heat generation, and the battery may burst, emit smoke or catch fire.
  - ⚠ **DANGER!** Use the battery only with the transceiver for which it is specified. Never use a battery with any other equipment, or for any purpose that is not specified in this instruction manual.
  - ⚠ **DANGER!** If fluid from inside the battery gets in your eyes, blindness can result. Rinse your eyes with clean water, without rubbing them, and see a doctor immediately.
  - **WARNING!** Immediately stop using the battery if it emits an abnormal odor, heats up, or is discolored or deformed. If any of these conditions occur, contact your Icom dealer or distributor.
  - **WARNING!** Immediately wash, using clean water, any part of the body that comes into contact with fluid from inside the battery.

- **WARNING! NEVER** put the battery in a microwave oven, high-pressure container, or in an induction heating cooker. This could cause a fire, overheating, or cause the battery to rupture.
- **CAUTION!** Always use the battery within the specified temperature range for the transceiver ( $-10^{\circ}\text{C}$  to  $+60^{\circ}\text{C}$ ;  $+14^{\circ}\text{F}$  to  $+140^{\circ}\text{F}$ ) and the battery itself ( $-20^{\circ}\text{C}$  to  $+60^{\circ}\text{C}$ ;  $-4^{\circ}\text{F}$  to  $+140^{\circ}\text{F}$ ). Using the battery out of its specified temperature range will reduce the battery's performance and battery life. Please note that the specified temperature range of the battery may exceed that of the transceiver. In such cases, the transceiver may not work properly because it is out of its operating temperature range.
- **CAUTION!** Shorter battery life could occur if the battery is left fully charged, completely discharged, or in an excessive temperature environment (above  $+50^{\circ}\text{C}$ ;  $+122^{\circ}\text{F}$ ) for an extended period of time. If the battery must be left unused for a long time, it must be detached from the radio after discharging. You may use the battery until the battery indicator shows half-capacity, then keep it safely in a cool dry place with the temperature between  $-20^{\circ}\text{C}$  to  $+20^{\circ}\text{C}$  ( $-4^{\circ}\text{F}$  to  $+68^{\circ}\text{F}$ ).

### ◇ Charging caution

- **⚠ DANGER! NEVER** charge the battery pack in areas with extremely high temperatures, such as near fires or stoves, inside a sun heated car, or in direct sunlight. In such environments, the safety/protection circuit in the battery will activate, causing the battery to stop charging.
- **WARNING! DO NOT** charge or leave the battery in the battery charger beyond the specified time for charging. If the battery is not completely charged by the specified time, stop charging and remove the battery from the battery charger. Continuing to charge the battery beyond the specified time limit may cause a fire, overheating, or the battery may rupture.
- **WARNING! NEVER** insert the transceiver (battery attached to the transceiver) into the charger if it is wet or soiled. This could corrode the battery charger terminals or damage the charger. The charger is not waterproof.
- **CAUTION! DO NOT** charge the battery outside of the specified temperature range:  $+5^{\circ}\text{C}$  to  $+35^{\circ}\text{C}$  ( $+41^{\circ}\text{F}$  to  $+95^{\circ}\text{F}$ ). Icom recommends charging the battery at  $+20^{\circ}\text{C}$  ( $+68^{\circ}\text{F}$ ). The battery may heat up or rupture if charged out of the specified temperature range. Additionally, battery performance or battery life may be reduced.

## 2 BATTERY CHARGING

### ■ Battery installation

Before installing, or replacing the battery pack, be sure to turn OFF the transceiver. If it's ON, push and hold [PWR] for 1 sec. to turn the power OFF.

- ① Remove the battery cover from the transceiver.

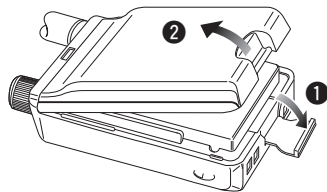

- ② Install the BP-243 (Li-Ion battery pack).
  - Be sure to observe the correct polarity.

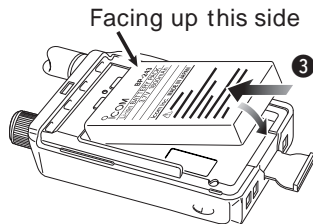

- ③ Replace the battery cover to the transceiver.

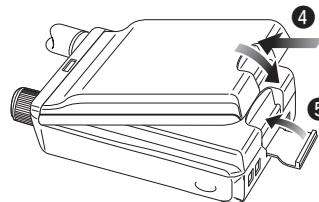

Keep the battery contacts clean to avoid rust or poor contact. It's a good idea to clean the battery terminals once a week.

## ■ Battery charging

### ◇ Charging connections

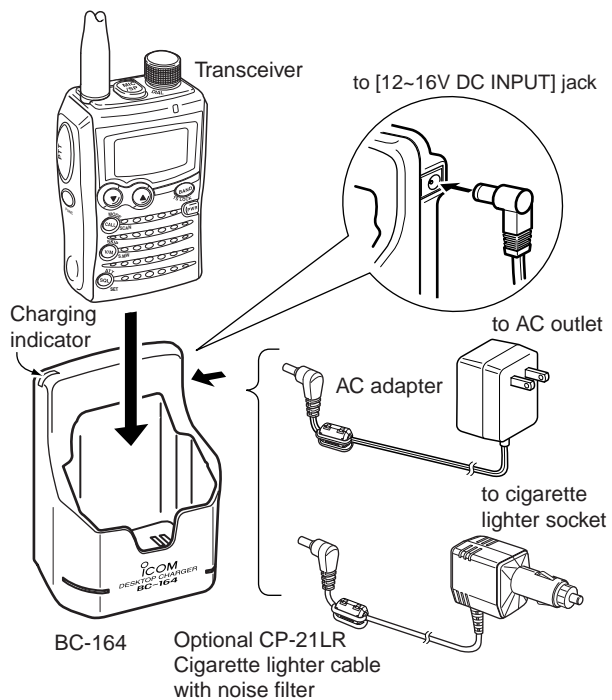

• **Charging periods:** Approx. 3 hours

### ◇ Charging description

- ① Plug the AC adapter into an AC outlet; or the optional CP-21LR into a cigarette lighter socket.
- ② Insert the adapter plug into **[12-16V DC INPUT]** of the BC-164 BATTERY CHARGER.
- ③ Install the BP-243 BATTERY PACK (See left page) in the transceiver
- ④ Be sure to turn OFF the transceiver, then charge the battery with transceiver.
  - Takes approximately 3 hours to fully charge with the supplied BP-243 battery pack.

**Charging indicator of BC -164**

Orange (lights) : During charging.  
 Green (lights) : When the battery pack is charged completely.  
 Red (blinking) : The charger may be outside of the specified temperature range: +5°C to +35°C (+41°F to +95°F). Restore the specified temperature range and reinsert the transceiver or contact your dealer.

**CAUTION: BE SURE** to disconnect the CP-21LR from the cigarette lighter socket when charging is finished, because, a slight current still follows in the CP-21LR and the vehicle's battery will become will be drained.

# 3

## FREQUENCY AND CHANNEL SETTING

### ■ VFO and memory channels

The IC-P7A has two primary operating modes: *VFO mode* and *memory mode*.

**VFO mode** is used for setting the desired frequency within the frequency coverage.

➔ Push **[V/M]** (**SKIP**•**S.MW**) to select *VFO mode*.

**Memory mode** is used for operating from memory channels which have programmed frequencies.

➔ Push **[V/M]** (**SKIP**•**S.MW**) to select *memory mode*.

• See p. 24 for memory programming details.

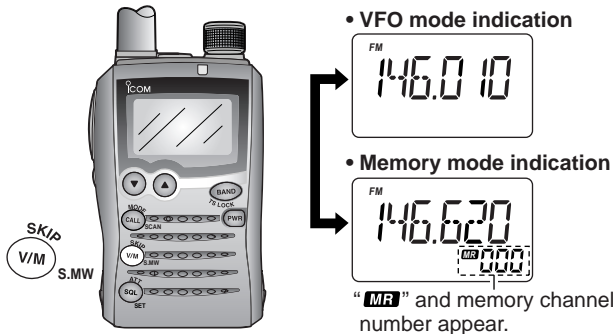

#### What is VFO?

VFO is an abbreviation of Variable Frequency Oscillator. Frequencies for receiving or transmitting are selected and controlled by the VFO.

### ■ Operating band selection

The transceiver can receive the AM broadcast, HF band, 50 MHz, FM broadcast, VHF air, 144 MHz, 300 MHz, 400 MHz, 600 MHz, \*800 MHz, television channels or †Weather channels.

▨ Available frequency bands are differ depending on version. See the specification for details. (p. 75)

▨ \*Some frequency ranges are inhibited for the USA version due to local regulation.

▨ †Available for the USA version only.

➔ Push **[BAND]** (**TS**•**LOCK**) several times to select the desired frequency band.

• When *memory mode* is selected, push **[V/M]** (**SKIP**•**S.MW**) to select *VFO mode* first.

➔ While pushing and holding **[BAND]** (**TS**•**LOCK**), rotating **[DIAL]** also selects frequency band.

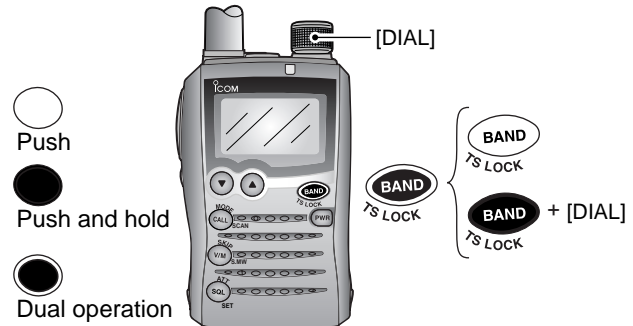

• Available frequency bands

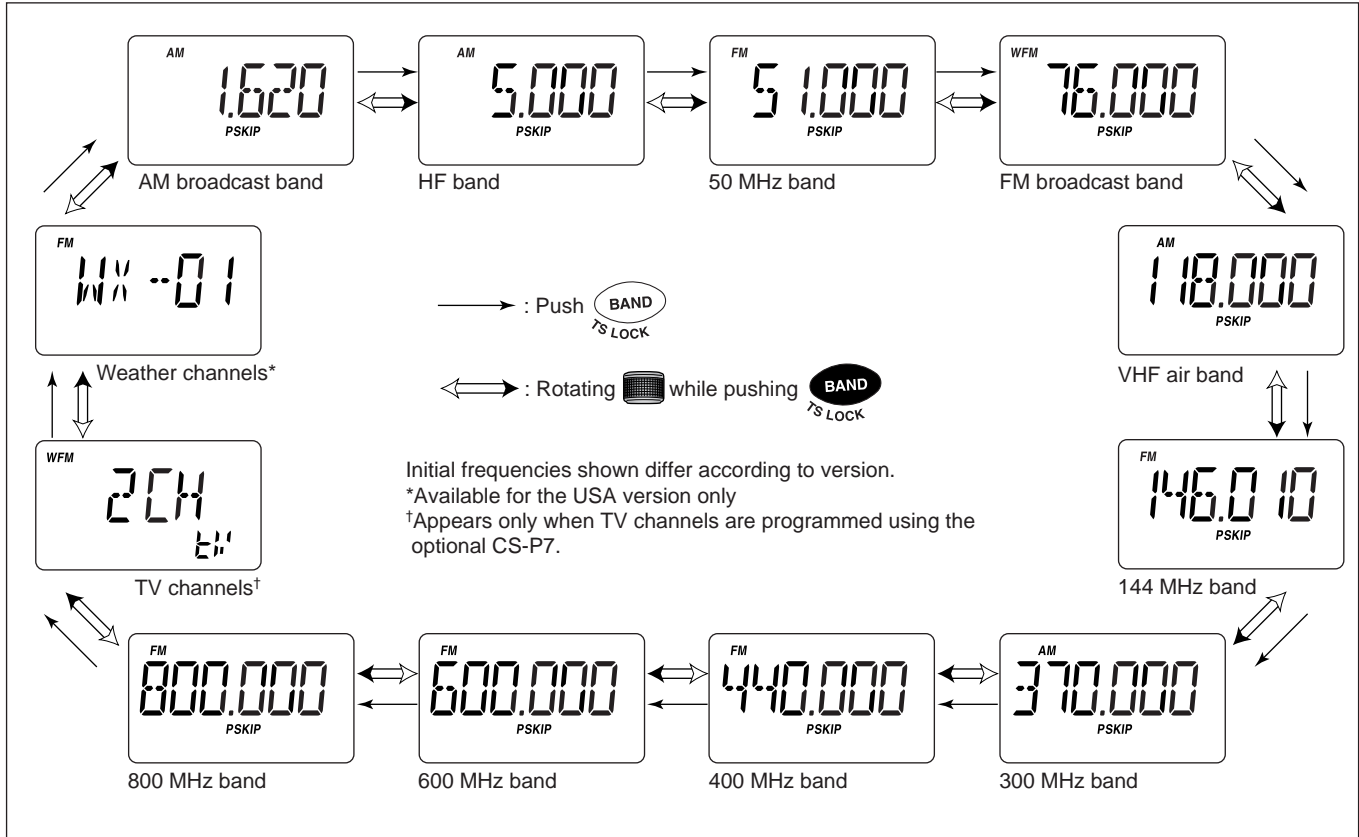

### 3 FREQUENCY AND CHANNEL SETTING

#### ■ Setting a frequency

- ① Push **[V/M]** (**SKIP•S.MW**) to select *VFO mode*, if necessary.
- ② Select the desired frequency band with **[BAND]** (**TS•LOCK**).
  - Or, while pushing and holding **[BAND]** (**TS•LOCK**), rotate **[DIAL]** to select the desired frequency band.
- ③ Rotate **[DIAL]** to select the desired frequency.
  - The frequency changes according to the preset tuning steps.
  - See the section at right for setting the tuning step.
  - While pushing and holding **[FUNC]**, rotate **[DIAL]** to change the frequency in 1 MHz steps (default).

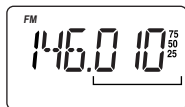
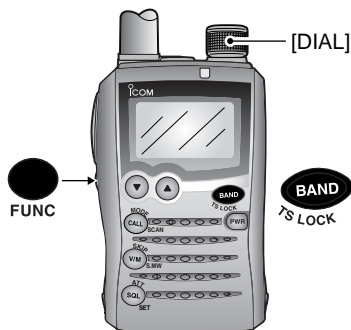

[DIAL] changes the frequency according to the selected tuning step.

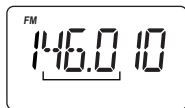

While pushing **[FUNC]**, **[DIAL]** changes the frequency in 1 MHz steps (default).

▨ The 1 MHz tuning step (dial select step) can be set to 100 kHz, 1 MHz or 10 MHz tuning steps in *set mode*. See p. 17 for details.

#### ■ Setting a tuning step

The tuning step can be selected for each frequency band. The following tuning steps are available for the IC-P7A.

- 5.0 kHz\* • 6.25 kHz\* • 8.33 kHz† • 9.0 kHz† • 10.0 kHz
- 12.5 kHz • 15.0 kHz • 20.0 kHz • 25.0 kHz • 30.0 kHz
- 50.0 kHz • 100.0 kHz • 200.0 kHz

\* Appears for below the 500 MHz bands only.

† Appears for the VHF air band only.

‡ Appears for the AM broadcast band only.

#### ◆ Tuning step selection

- ① Push **[V/M]** (**SKIP•S.MW**) to select *VFO mode*, if necessary.
- ② Push **[BAND]** (**TS•LOCK**) several times to select the desired frequency band.
  - Or, while pushing and holding **[BAND]** (**TS•LOCK**), rotate **[DIAL]** to select the desired frequency band.
- ③ While pushing and holding **[FUNC]**, push **[BAND]** (**TS•LOCK**) momentarily to enter *tuning step set mode*.
- ④ Rotate **[DIAL]** to select the desired tuning step.
- ⑤ Push **[BAND]** (**TS•LOCK**) to return to *VFO mode*.



5 kHz tuning step



## ■ Selecting a memory channel

- ① Push **[V/M]** (**SKIP•S.MW**) momentarily to select *memory mode*.
  - “**MR**” appears when a memory channel is selected.
- ② Rotate **[DIAL]** to select the desired memory channel.
  - Only programmed memory channels can be selected.
  - While pushing and holding **[FUNC]**, rotate **[DIAL]** to select a memory channel in 10 channel steps, blank channels can be selected in this case.

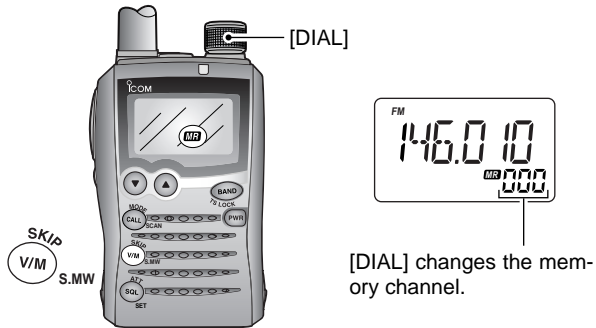

## ■ Selecting a call channel

- ① Push **[CALL]** (**MODE•SCAN**) momentarily to select a call channel.
- ② Rotate **[DIAL]** to select the desired call channel.



- ③ Push **[CALL]** (**MODE•SCAN**) or **[V/M]** (**SKIP•S.MW**) momentarily to return to the previously selected mode.

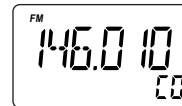

### • Call channel example (depends on version)



144 MHz band



440 MHz band

 Push	 Push and hold	 Dual operation
---	--	---

## ■ Receiving

Make sure charged battery pack (BP-243) is installed (p. 7).

- ① Push and hold **[PWR]** for 1 sec. to turn power ON.
- ② Push **[▲]** or **[▼]** to set the desired audio level.
  - The frequency display shows the volume level while setting. See the section at right for details.
- ③ Set the receiving frequency. (p. 11)
- ④ Set the squelch level. (p. 14)
  - While pushing and holding **[SQL]** (**ATT\*SET**), rotate **[DIAL]**.
  - The first click of **[DIAL]** indicates the current squelch level.
  - “LEVEL 1” is loose squelch (for weak signals) and “LEVEL 9” is tight squelch (for strong signals).
  - “AUTO” indicates automatic level adjustment by a noise pulse counting system.
  - Push and hold **[SQL]** (**ATT\*SET**) to open the squelch manually.
- ⑤ When a signal is received:
  - TX/RX indicator lights green.
  - Squelch opens and audio is emitted.
  - The S/RF meter shows the relative signal strength level.

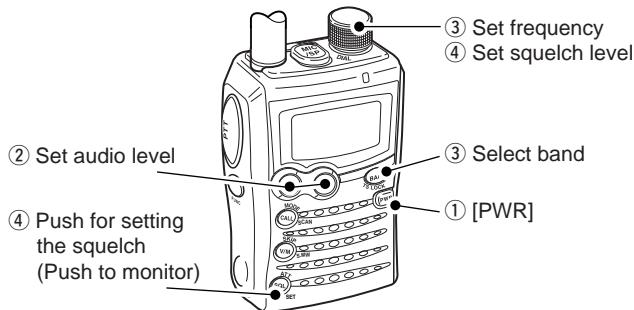

## ■ Setting audio volume

The audio level can be adjusted to one of 40 levels.

- ➔ Push **[▲]** or **[▼]** to adjust the audio level.
  - If squelch is closed, push and hold **[SQL]** (**ATT\*SET**) to verify the audio level.
  - Pushing and holding either key changes the audio level continuously.
  - The display shows the volume level while setting.

INDICATION	AUDIO LEVEL
-----00	Minimum setting (no audio)
0-----01	•
00-----08	•
000-----16	•
0000-----19	Initial setting
0000-----24	•
00000-----32	•
000000-----39	Maximum setting



## ■ Squelch level setting

The squelch circuit mutes the received audio signal depending on the signal strength. The transceiver has 9 squelch levels, a continuously open setting and an automatic squelch setting.

- ➔ While pushing and holding **[SQL]** (**ATT•SET**), rotate **[DIAL]** to select the squelch level.
  - “LEVEL 1” is loose squelch (for weak signals) and “LEVEL 9” is tight squelch (for strong signals).
  - “AUTO” indicates automatic level adjustment by a noise pulse counting system.
  - “OPEN” indicates continuously open setting.

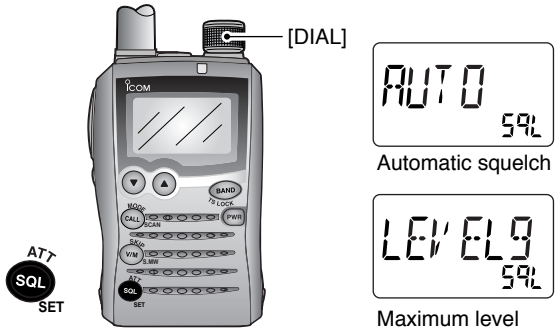

	Push		Push and hold		Dual operation
--	------	--	---------------	--	----------------

## ■ Operating mode selection

Operating modes are determined by the modulation of the radio signals. The transceiver has 3 operating modes: FM, AM and WFM modes. The mode selection is stored independently in each band and memory channels.

Typically, AM mode is used for the AM broadcast stations (0.495–1.620 MHz) and air band (118–135.995 MHz), and WFM is used for FM broadcast stations (76–107.9 MHz). WFM mode cannot be selected below 30 MHz bands for all versions (and above 850 MHz bands for USA version).

- ➔ While pushing and holding **[FUNC]**, push **[CALL]** (**MODE•SCAN**) several times to select the desired operating mode.



## 4 BASIC OPERATION

### ■ Monitor function

This function is used to listen to weak signals without disturbing the squelch setting or to open the squelch manually even when mute functions such as the tone squelch are in use.

- ➔ Push and hold **[SQL] (ATT•SET)** to monitor the operating frequency.

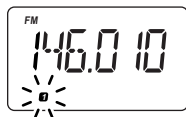

The 1st segment blinks

/// The **[SQL] (ATT•SET)** key can be set to 'sticky' operation in *expanded set mode*. See page 56 for details.

### ■ Attenuator function

The attenuator prevents distortion of a desired signal when very strong RF signals are near the desired frequency or when very strong electric fields, such as from a broadcasting station, are present at your location.

- ➔ While pushing and holding **[FUNC]**, push **[SQL] (ATT•SET)** momentarily to toggle the attenuator function ON and OFF.
  - “ATT” appears when the attenuator functions is in use.

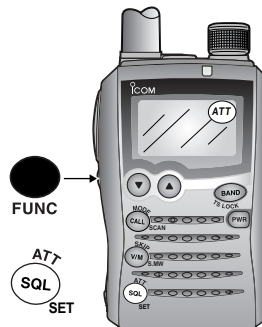

○ Push    ● Push and hold    ◐ Dual operation

## ■ Transmitting

**CAUTION:** Transmitting without an antenna will damage the transceiver.

**NOTE:** To prevent interference, listen on the channel before transmitting by pushing and holding **[SQL] (ATT•SET)**.

- ① Set the operating frequency. (pgs. 9, 11)
  - Transmission is available on the 144 MHz/440 MHz (FM mode) amateur bands only.
  - Select output power if desired. See the section at right for details.
- ② Push and hold **[PTT]** to transmit.
  - TX/RX indicator lights red.
  - S/RF meter shows the output power level.
- ③ Speak into the microphone using your normal voice level.
  - DO NOT hold the transceiver too close to your mouth or speak too loudly. This may distort the signal.
- ④ Release **[PTT]** to return to receive.

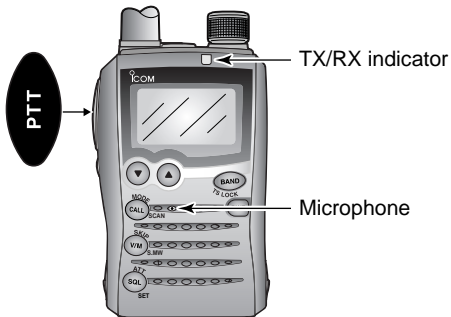

## ■ Transmit power selection

The transceiver has two output power levels to suit your operating requirements. Low output power during short-range communications may reduce the possibility of interference to other stations and will reduce current consumption.

- ➔ While pushing and holding **[FUNC]**, push **[PTT]** to toggle the transmit output power between High and Low.
  - "LOW" appears when the low power is selected.

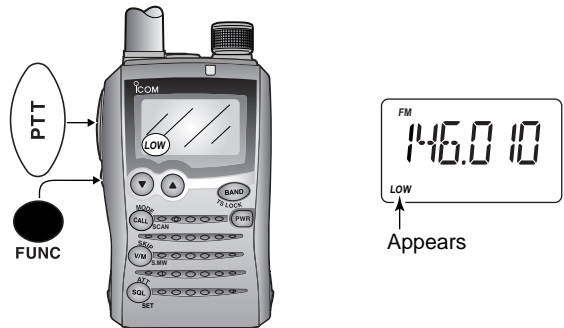

## 4 BASIC OPERATION

### ■ Dial select step

This transceiver has a 1 MHz tuning step for quick frequency setting. This dial select step can be set to 100 kHz, 1 MHz or 10 MHz steps, as desired.

#### ◆ Setting dial select step

- ① Select *VFO mode* with [V/M] (SKIP\***S**.MW).
- ② While pushing and holding [FUNC], push and hold [SQL] (ATT\***SET**) for 1 sec. to enter *set mode*.

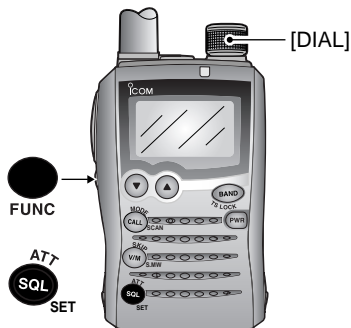

- ③ Rotate [DIAL] to select "D SEL."

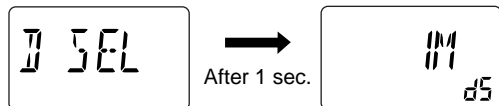

Dial select step item

Setting indication

USING SET MODE

- ④ While pushing and holding [FUNC], rotate [DIAL] to select the desired dial select step.

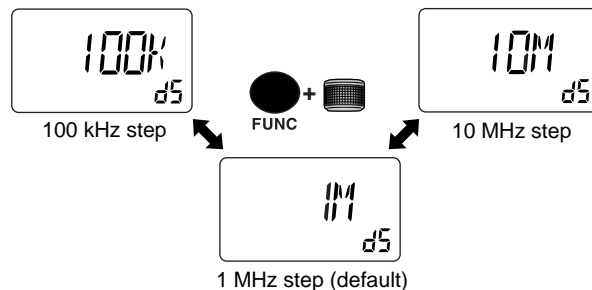

- ⑤ Push [SQL] (ATT\***SET**) momentarily to exit *set mode*.

○ Push    ● Push and hold    ◐ Dual operation

## ■ Lock function

To prevent accidental frequency changes and unnecessary function activation, use the lock function.

- ➔ While pushing and holding **[FUNC]**, push and hold **[BAND] (TS•LOCK)** for 1 sec. to turn the lock function ON and OFF.
  - “L” appears while the lock function is active.
  - **[SQL] (ATT•SET)** and **[▲]/[▼]** can be used while the lock function is in use in default setting. Either or both **[SQL] (ATT•SET)** and **[▲]/[▼]** keys may also be locked in *set mode*. (p. 56)

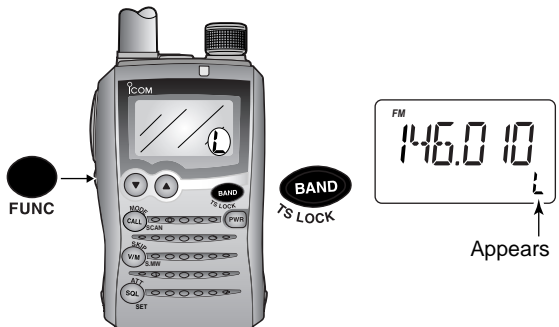

## ■ [DIAL] function assignment

The **[DIAL]** control can be used as an audio volume control instead of **[▲]/[▼]** keys to suit your preference. However, while **[DIAL]** functions as an audio volume, **[▲]/[▼]** keys function as tuning controls.

- ➔ While pushing and holding **[FUNC]**, push **[▲]/[▼]** to toggle the **[DIAL]** function between tuning dial and audio volume.
  - “VOL” appears when **[DIAL]** functions as an audio volume.



### • [DIAL] and [▲]/[▼] functions

	No “VOL” indication	“VOL” appears
<b>[DIAL]</b>	Frequency, Memory channel, Squelch level, Scanning direction, Set mode item and condition set	Audio volume set Set mode condition set
<b>[▲]/[▼]</b>	Audio volume set	Frequency, Memory channel, Squelch level, Scanning direction, Set mode item

## ■ General

When using a repeater, the transmit frequency is shifted from the receive frequency by the amount of the offset frequency. It is convenient to program repeater information, such as offset and access tone, into memory channels.

- ① Set the receive frequency (repeater output frequency).
- ② Set the shift direction of the transmit offset frequency. (-DUP or +DUP; see the next section for details.)
  - “-DUP” or “+DUP” indicates a minus or plus offset of the transmit frequency, respectively.
  - When the auto repeater function is in use (USA/KOREA versions only), this selection and step ③ are not necessary. (p. 23)
- ③ Activate the subaudible tone encoder, according to repeater requirements.
  - Refer to page 21 for tone frequency settings.
- ④ Push and hold **[PTT]** to transmit.
  - The displayed frequency automatically changes to the transmit frequency (repeater input frequency).
  - If “OFF” appears, check the offset frequency (see next page for details) or shift direction (see section at right).
- ⑤ Release **[PTT]** to receive.
- ⑥ Push and hold **[SQL] (ATT•SET)** to check whether the other station’s transmit signal can be received directly on the repeater’s input frequency.

### ◆ Setting duplex and duplex direction

- ① While pushing and holding **[FUNC]**, push and hold **[SQL] (ATT•SET)** for 1 sec. to enter *set mode*.

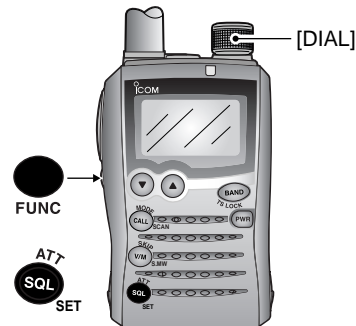

- ② Rotate **[DIAL]** to select “DUP.”

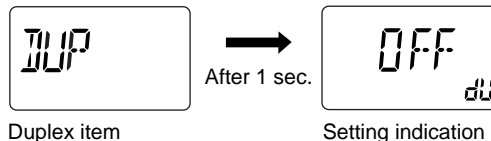

- ③ While pushing and holding **[FUNC]**, rotate **[DIAL]** to select “-DUP” or “+DUP.”
- ④ Push **[SQL] (ATT•SET)** to exit *set mode*.
- ⑤ Push and hold **[SQL] (ATT•SET)** to monitor the repeater input frequency.



## ■ Offset frequency

When communicating through a repeater, the transmit frequency is shifted from the receive frequency by the amount of the offset frequency.

- ① While pushing and holding **[FUNC]**, push and hold **[SQL] (ATT•SET)** for 1 sec. to enter *set mode*.

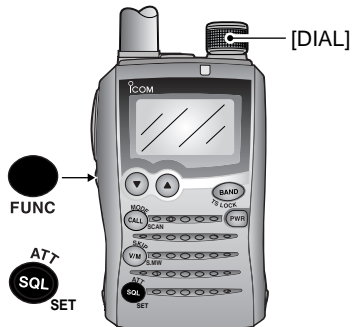

- ② Rotate **[DIAL]** to select “OFFSET.”

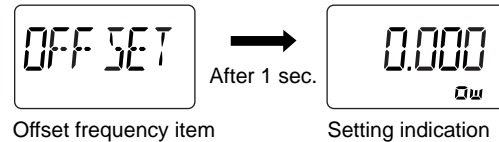

- ③ While pushing and holding **[FUNC]**, rotate **[DIAL]** to set the desired offset frequency within 0.000–159.995 MHz range.
  - The tuning step, selected in *VFO mode*, is used for setting.
- ④ Push **[SQL] (ATT•SET)** to exit *set mode*.

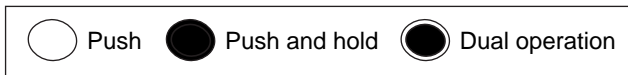

## 5 REPEATER OPERATION

### ■ Subaudible tones

To be accessed, some repeaters require subaudible tones on the input signal. Subaudible tones are added to your normal signal and must be set in advance.

#### ◆ Setting the subaudible tone frequency

- ① While pushing and holding **[FUNC]**, push and hold **[SQL]** (**ATT•SET**) for 1 sec. to enter *set mode*.

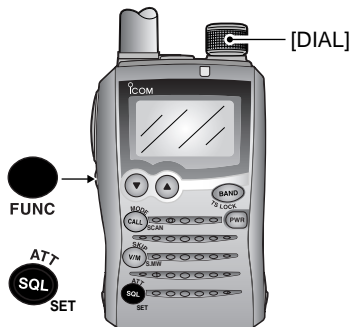

- ② Rotate **[DIAL]** to select “R TONE.”



- ③ While pushing and holding **[FUNC]**, rotate **[DIAL]** to select the desired subaudible tone frequency.  
• See the tables at right.
- ④ Push **[SQL]** (**ATT•SET**) to exit *set mode*.

#### • Available tone frequency list

67.0	79.7	94.8	110.9	131.8	156.7	171.3	186.2	203.5	229.1
69.3	82.5	97.4	114.8	136.5	159.8	173.8	189.9	206.5	233.6
71.9	85.4	100.0	118.8	141.3	162.2	177.3	192.8	210.7	241.8
74.4	88.5	103.5	123.0	146.2	165.5	179.9	196.6	218.1	250.3
77.0	91.5	107.2	127.3	151.4	167.9	183.5	199.5	225.7	254.1

NOTE: The transceiver has 50 tone frequencies and consequently their spacing is narrow compared to units having 38 tones. Therefore, systems using some tone frequencies may receive interference from signals using adjacent tone frequencies.

#### ✓ CONVENIENT!

**Tone scan function:** When you don't know the subaudible tone used for a repeater, the tone scan is convenient for detecting the tone frequency. (p. 48)

While pushing and holding **[FUNC]**, pushing and holding **[CALL]** (**MODE•SCAN**) for 1 sec. to start the repeater tone scan.

- Push **[CALL]** (**MODE•SCAN**) to cancel the scan.
- When the required tone frequency is detected, the scan pauses.

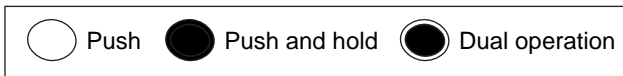

◆ **Setting the subaudible tone encoder ON/OFF**

- ① While pushing and holding **[FUNC]**, push and hold **[SQL] (ATT\*SET)** for 1 sec. to enter *set mode*.
- ② Rotate **[DIAL]** to select “T/TSQL.”



- ③ While pushing and holding **[FUNC]**, rotate **[DIAL]** to select the repeater tone from “TONE” or “OFF.”

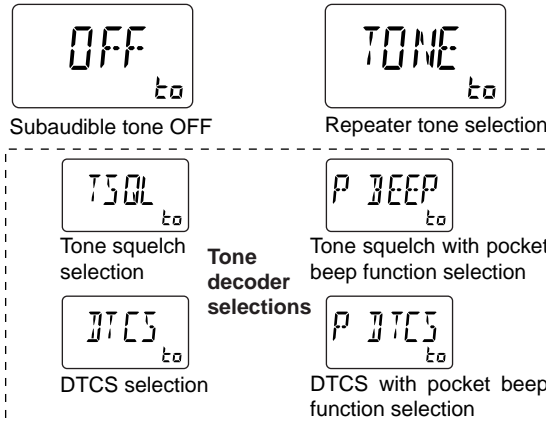

- ④ Push **[SQL] (ATT\*SET)** to exit *set mode*.

■ **1750 Hz tone**

Some European repeaters require a 1750 Hz tone burst to be accessed. For such European repeaters, perform the following.

- ① Set the receive frequency (repeater output frequency).
- ② Set the shift direction of the transmit frequency. (-DUP or +DUP; see p. 19 for details.)
  - “-DUP” or “+DUP” indicates a minus or plus offset of the transmit frequency, respectively.
- ③ While pushing and holding **[PTT]**, push and hold **[SQL] (ATT\*SET)** for 1 to 2 sec. to transmit a 1750 Hz tone burst signal.
  - The displayed frequency automatically changes to the transmit frequency (repeater input frequency).
  - If “OFF” appears, check the offset frequency (see next page for details) or shift direction (right section).
- ④ Push and hold **[PTT]** to transmit.
- ⑤ Release **[PTT]** to receive.
- ⑥ Push and hold **[SQL] (ATT\*SET)** to monitor the repeater input frequency.

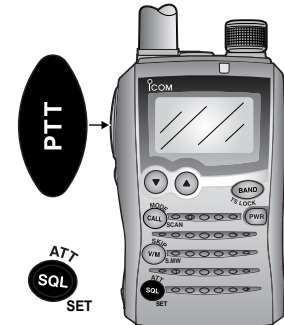

## 5 REPEATER OPERATION

### ■ Auto repeater function

The USA/KOREA versions automatically activate the repeater settings when the operating frequency falls within or outside of the general repeater output frequency range. The offset and repeater tone frequencies are not changed by the auto repeater function. Reset these frequencies, if necessary.

- ① While pushing and holding **[FUNC]**, push and hold **[SQL] (ATT•SET)** for 1 sec. to enter *set mode*.

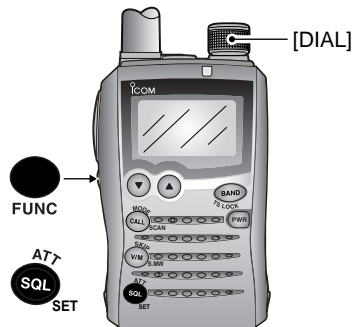

- ② Rotate **[DIAL]** to select "AUTORP."



#### USA/KOREA versions only

- ③ While pushing and holding **[FUNC]**, rotate **[DIAL]** to select the desired condition.

#### U.S.A. version:

- OFF : The auto repeater function is turned OFF.
- DUP ONLY : Activates duplex offset only. (default)
- DUP TONE : Activates duplex and tone.

#### Korea version:

- OFF : Deactivates the function.
- ON : Activates duplex and tone. (default)

- ④ Push **[SQL] (ATT•SET)** to exit *set mode*.

#### ◇ Frequency range and offset direction

##### • U.S.A. version:

Frequency range	Duplex direction
145.200–145.495 MHz 146.610–146.995 MHz	"-" appears
147.000–147.395 MHz	"+" appears
442.000–444.995 MHz	"+" appears
447.000–449.995 MHz	"-" appears

##### • Korea version:

Frequency range	Duplex direction
439.000–440.000 MHz	"-" appears

## ■ General description

The IC-P7A has 1050 memory channels including 50 scan edge memory channels (25 pairs) for storage of often-used frequencies. And a total of 18 memory banks, A to H, J, L, N, O to R, T, U and Y are available for storing groups of frequencies, etc. Up to 100 channels can be assigned into a bank.

### ◇ Memory channel contents

The following information can be programmed into memory channels:

- Operating frequency (p. 11)
- Operating mode (p. 14)
- Duplex direction (DUP or -DUP) with an offset frequency (pgs. 19, 20)
- Subaudible tone encoder (p. 22), tone squelch or DTCS squelch ON/OFF (p. 45)
- Subaudible tone frequency (p. 21), tone squelch frequency or DTCS code with polarity (pgs. 46, 47)
- Scan skip information (p. 39).

## ■ Memory channel programming

- ① Push **[V/M]** (**SKIP•S.MW**) to select *VFO mode*.
- ② Set the desired frequency:
  - Select the desired band with **[BAND]** (**TS•LOCK**).
  - Set the desired frequency with **[DIAL]**.
  - Set other data (e.g. offset frequency, duplex direction, sub-audible tone frequency, etc.), if desired.
- ③ Push and hold **[V/M]** (**SKIP•S.MW**) for 1 sec. to enter *select memory write mode*.
  - 1 short and 1 long beep sound.
  - “**MR**” indicator and memory channel number blink.
- ④ Rotate **[DIAL]** to select the desired channel.
  - Call channels (C0, C1), VFO (VF) and scan edge channels (00A/00b to 24A/24b), as well as regular memory channels, can be programmed in this way.
  - While pushing and holding **[FUNC]**, rotate **[DIAL]** to select memory channel in 10 channel steps.
- ⑤ Push and hold **[V/M]** (**SKIP•S.MW**) for 1 sec.
  - 3 beeps sound
  - Memory channel number automatically increases when continuing to push **[V/M]** (**SKIP•S.MW**) after programming.

5

6

**[EXAMPLE]:** Programming 145.870 MHz into memory channel 20 (blank channel).

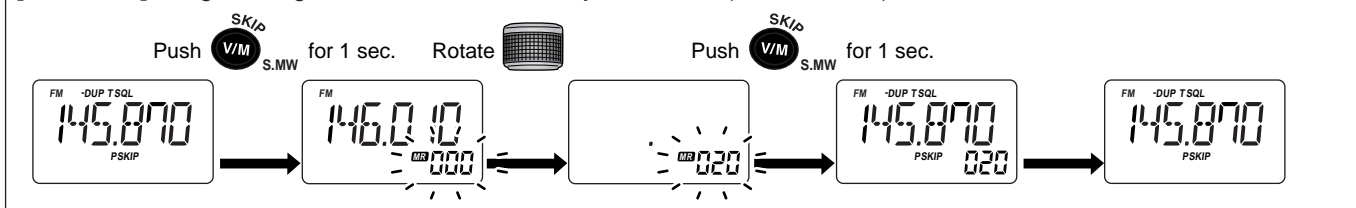

## 6 MEMORY/CALL CHANNELS

### ■ Memory bank setting

The IC-P7A has a total of 18 banks (A to H, J, L, N, O to R, T, U and Y). Regular memory channels, 000 to 999, may assigned into a desired bank for easy memory management.

- ① Push and hold **[V/M]** (**SKIP•S.MW**) for 1 sec. to enter *select memory write mode*.
  - 1 short and 1 long beep sound.
  - “**MR**” indicator and memory channel number blink.
- ② Rotate **[DIAL]** to select the desired memory channel.
- ③ While pushing and holding **[CALL]** (**MODE•SCAN**), rotate **[DIAL]** to select “BANK.”
  - After releasing **[CALL]** (**MODE•SCAN**), “- - - - -” is displayed instead of the frequency indication, and only “**MR**” indicator blinks.
  - Bank group and channel number is displayed if the selected memory channel has already been assigned to a bank.
  - “BANK” can also be selected by pushing **[CALL]** (**MODE•SCAN**) several times.



- ④ While pushing and holding **[BAND]** (**TS•LOCK**), rotate

**[DIAL]** to select the desired bank.

- Banks A to H, J, L, N, O to R, T, U and Y are available.
- The bank can also be selected by pushing **[BAND]** (**TS•LOCK**) several times.

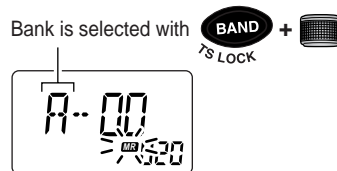

- ⑤ Rotate **[DIAL]** to select the desired bank channel number.
  - Vacant bank channel numbers are only be displayed.

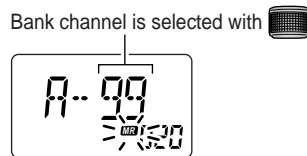

- ⑥ Push and hold **[V/M]** (**SKIP•S.MW**) for 1 sec. to set the channel into the bank.
  - Return to the previous indication.

## Memory bank selection

- ① Push [V/M] (SKIP\*s.mw) to select *memory mode*, if desired.
- ② While pushing and holding [BAND] (TS•Lock), rotate [DIAL] to select the desired bank (A to H, J, L, N, O to R, T, U and Y).
  - The bank can also be selected by pushing [BAND] (TS•Lock) several times.
  - The only programmed banks are displayed.

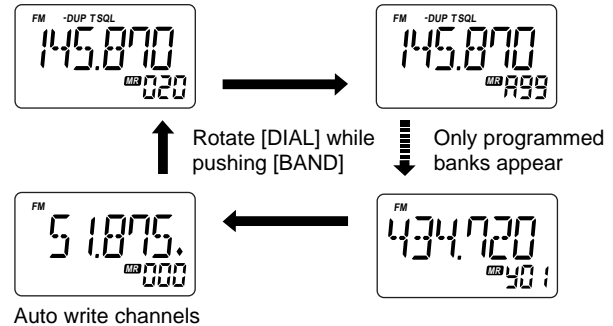

- ③ Rotate [DIAL] to select the bank channel.
  - Only programmed channels are displayed.

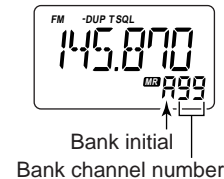

- ④ To return to regular memory operation, rotate [DIAL] while pushing and holding [BAND] (TS•Lock), or push [BAND] (TS•Lock) several times.

○ Push    ● Push and hold    ● Dual operation

## ■ Programming memory/bank name

Each memory channel can be programmed with an alphanumeric channel name for easy recognition and that can be indicated independently by channel. Names can be a maximum of 6 characters.

- ① Push **[V/M]** (**SKIP•S.MW**) to select *memory mode*.
- ② Rotate **[DIAL]** to select the desired memory channel.
- ③ Push and hold **[V/M]** (**SKIP•S.MW**) for 1 sec. to enter *select memory write mode*.
  - 1 short and 1 long beep sound.
  - “**MR**” indicator and memory channel number blink.

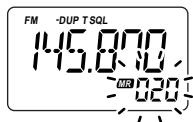

- ④ While pushing and holding **[CALL]** (**MODE•SCAN**), rotate **[DIAL]** to select “M NAME” or “B NAME” when programming the memory name or the bank name, respectively.
  - Name type can also be selected by pushing **[CALL]** (**MODE•SCAN**) several times.
  - After releasing **[CALL]** (**MODE•SCAN**), an under bar blinks for the first digit instead of the frequency indication, and only “**MR**” indicator blinks.

Memory name selection

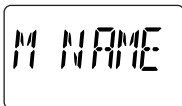

Bank name selection

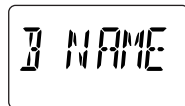

- ⑤ While pushing and holding **[FUNC]**, rotate **[DIAL]** to select the desired character.
  - The selected character blinks.
- ⑥ Rotate **[DIAL]** to move the cursor to left or right.

Memory name

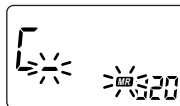

Bank name

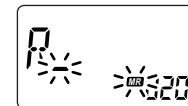

- ⑦ Repeat steps ⑤ and ⑥ until the desired 6-character channel names are displayed.
- ⑧ Push **[CALL]** (**MODE•SCAN**) several times, or rotate **[DIAL]** while pushing and holding **[CALL]** (**MODE•SCAN**) to select “S.MW.”

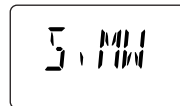

- ⑨ Push and hold **[V/M]** (**SKIP•S.MW**) for 1 sec. to program the name and exit the channel name programming.
  - 3 beeps sound.

### • Available characters

A to Z, 0 to 9, (, ), \*, +, -, ., /, :, = and space.



## ■ Selecting display type

During *memory mode* operation, the programmed memory name, bank name or the channel number can be displayed instead of the frequency at your preference.

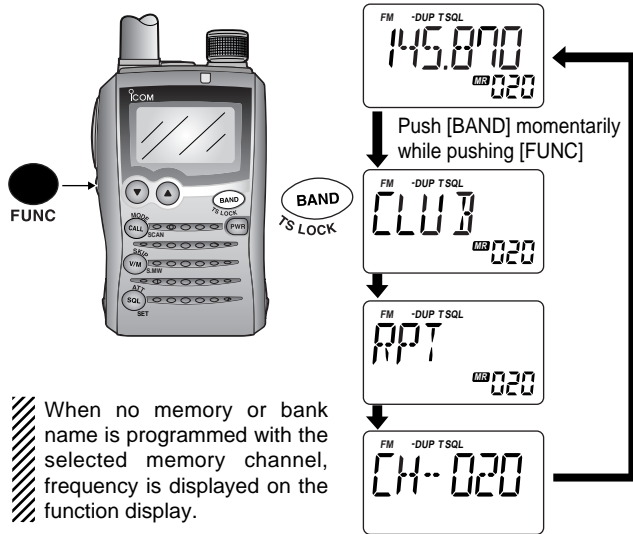

When no memory or bank name is programmed with the selected memory channel, frequency is displayed on the function display.

- ① Push **[V/M]** (SKIP\*S.MW) to select *memory mode*.
  - **[BAND]** (TS LOCK) to select the desired bank.
- ② While pushing and holding **[FUNC]**, push **[BAND]** (TS LOCK) momentarily to select display type from frequency, bank name, memory name and channel number display.

## ◇ Selecting bank channel indication

During bank channel operation, the bank channel number can also be displayed instead of the memory channel number indication.

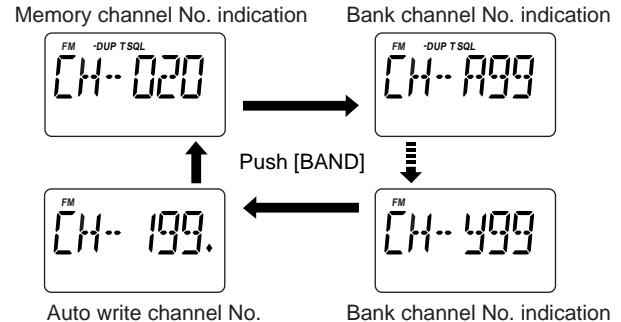

- After selecting channel number indication as described at left, push **[BAND]** (TS LOCK) to select the desired bank. Or while pushing and holding **[BAND]** (TS LOCK), rotate **[DIAL]** to select the desired bank.

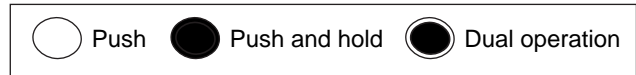

## ■ Copying memory contents

This function transfers a memory channel's contents to a VFO (or another memory channel). This is useful when searching for signals around a memory channel frequency and for recalling the offset frequency, subaudible tone frequency etc.

### ◇ Memory ↔ VFO

- ① Select the memory channel to be copied.
  - Push **[V/M] (SKIP•S.MW)** momentarily to select *memory mode*, then rotate **[DIAL]** to select the desired memory channel.
    - Select the bank channel with **[BAND] (TS•Lock)** and **[DIAL]**, if desired.
- ② Push and hold **[V/M] (SKIP•S.MW)** for 1 sec. to enter *select memory write mode*.
  - 1 short and 1 long beep sound.
  - “**MR**” indicator and memory channel number blink.
- ③ Rotate **[DIAL]** to select “VF.”
- ④ Push and hold **[V/M] (SKIP•S.MW)** for 1 sec. again.
  - *VFO mode* is selected automatically.

/// Pushing and holding **[V/M] (SKIP•S.MW)** for 2 sec. at the step ②, can also copies the memory contents to VFO. In this case, steps ③ and ④ are not necessary.

### ◇ Memory ↔ memory

- ① Select the memory channel to be transferred.
  - Push **[V/M] (SKIP•S.MW)** to select *memory mode*, then rotate **[DIAL]** to select the desired memory channel.
- ② Push and hold **[V/M] (SKIP•S.MW)** for 1 sec. to enter *select memory write mode*.
  - 1 short and 1 long beep sound.
  - “**MR**” indicator and memory channel number blink.
  - Do not hold **[V/M] (SKIP•S.MW)** for more than 1 sec. otherwise the memory contents will be copied to VFO.
- ③ Rotate **[DIAL]** to select the target memory channel.
- ④ Push and hold **[V/M] (SKIP•S.MW)** for 1 sec. again to transfer.

**[EXAMPLE]:** Copying channel 20 to 51.

Select memory channel

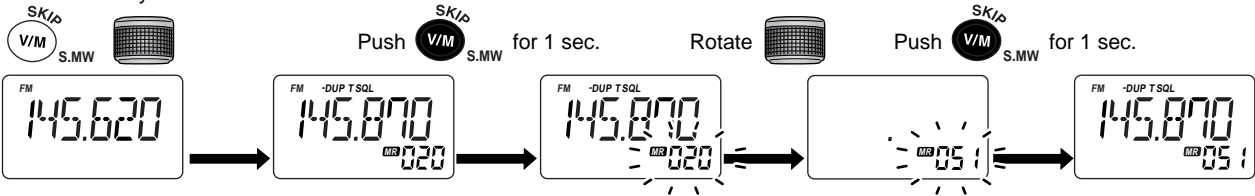

## Memory clearing

Contents of programmed memories can be cleared (blanked), if desired.

- ① Push and hold **[V/M] (SKIP\*S.MW)** for 1 sec. to enter *select memory write mode*.
  - 1 short and 1 long beeps sound.
  - “**MR**” indicator and memory channel number blink.
  - Do not hold **[V/M] (SKIP\*S.MW)** for more than 2 sec. otherwise the memory contents will be copied to VFO.
- ② Rotate **[DIAL]** to select the desired memory channel to be cleared.
- ③ While pushing and holding **[CALL] (MODE\*SCAN)**, rotate **[DIAL]** to select “CLEAR.”
  - “CLEAR” item can also be selected by pushing **[CALL] (MODE\*SCAN)** several times.

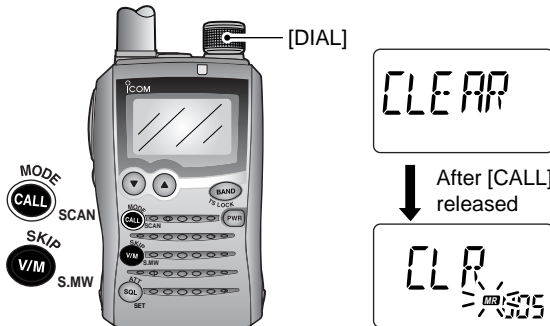

- ④ Push and hold **[V/M] (SKIP\*S.MW)** for 1 sec. to clear the contents.
  - 3 beeps sound.
  - Return to VFO or *memory mode*, if VFO is selected before performing step ①.
  - Return to *select memory write mode* if *memory mode* is selected before performing step ①.— “**MR**” indicator and memory channel number blink. Push **[V/M] (SKIP\*S.MW)** momentarily to return to *memory mode*.

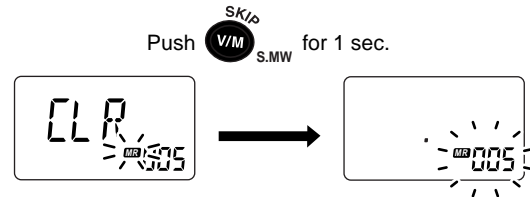

While pushing and holding **[FUNC]**, push and hold **[V/M] (SKIP\*S.MW)** for 1 sec. after step ② also clears the memory contents. In this case, steps ③ and ④ are not necessary.

**NOTE:** Be careful!— the contents of cleared memories CANNOT be re-called even in bank channel operation.

