

■ VOX function	6-2
◇ Using the VOX function	6-2
◇ Adjusting the VOX function	6-2
◇ VOX set mode	6-2
■ Break-in function	6-3
◇ Semi break-in operation	6-3
◇ Full break-in operation	6-3
■ ΔTX function	6-4
◇ ΔTX monitor function	6-4
■ Monitor function	6-4
■ Transmit filter width setting (SSB only)	6-5
■ Speech compressor (SSB only)	6-5
■ Split frequency operation	6-6
■ Quick split function	6-7
◇ Split lock function	6-7

■ VOX function

The VOX (Voice-Operated Transmission) function switches between transmit and receive with your voice. This function provides “hands-free” operation.

◇ Using the VOX function

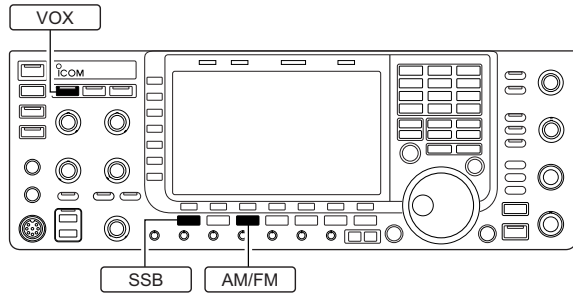

- ① Select a phone mode (SSB, AM, FM).
- ② Push **VOX** to turn the VOX function ON or OFF.
 - “**VOX**” appears while the VOX is in use.
 - [VOX] indicator above this switch lights green.

◇ Adjusting the VOX function

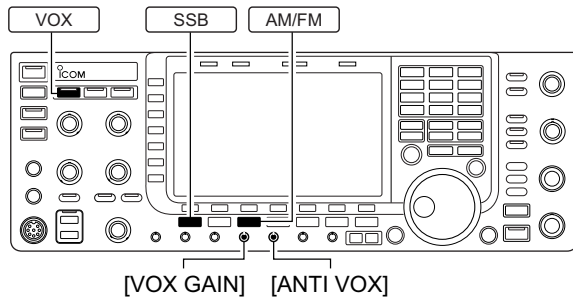

- ① Select a phone mode (SSB, AM, FM).
- ② Push **VOX** to turn VOX function ON.
- ③ While speaking into the microphone with your normal voice level, rotate [VOX GAIN] to the point where the transceiver is continuously transmitting.
- ④ During receive, rotate [ANTI VOX] to the point where the transceiver does not switch to transmit due to received audio from the speaker.
- ⑤ Adjust the VOX delay and the VOX voice delay in VOX set mode, if necessary.

◇ VOX set mode



- ① Push and hold **VOX** for 1 sec. to enter VOX set mode.
- ② Select the desired item using **[▲] F-1** or **[▼] F-2**.
- ③ Rotate the main dial to the desired set value or condition.
 - Push and hold **[DEF] F-4** for 1 sec. to select a default value.
- ④ Push **[EXIT/SET]** to exit VOX set mode.

VOX Delay

0.2s

Set the VOX delay for a convenient interval before returning to receive within 0 to 2.0 sec. range.

VOX Voice Delay

Short

Set the VOX voice delay to prevent unintended transmission of your voice when switching to transmit. Short, Mid., Long and OFF settings are available.

When using the VOX voice delay, turn the TX monitor function OFF to prevent transmitted audio from be echoed.

■ Break-in function

The break-in function is used in CW mode to automatically toggle the transceiver between transmit and receive when keying. The IC-7700 is capable of full break-in or semi break-in.

◇ Semi break-in operation

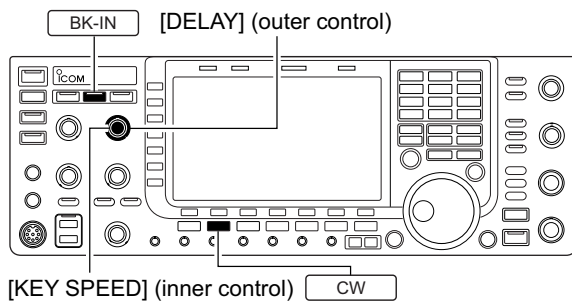

During semi break-in operation, the transceiver selects transmit when keying, then automatically returns to receive after a pre-set time after you stop sending.

- ① Push **CW** to select CW or CW-R mode.
- ② Push **BK-IN** once or twice to turn the semi break-in function ON.
 - “**BKIN**” appears.
- ③ Rotate **[DELAY]** to set the break-in delay time (the delay from transmit to receive).

▨ When using a paddle, rotate **[KEY SPEED]** to adjust the keying speed.

◇ Full break-in operation



During full break-in operation, the transceiver automatically enters transmit while keying and returns to receive immediately after keying is finished.

- ① Push **CW** to select CW or CW-R mode.
- ② Push **BK-IN** once or twice to turn the full break-in function ON.
 - “**F-BKIN**” appears.

▨ When using a paddle, rotate **[KEY SPEED]** to adjust the keying speed.

■ Δ TX function

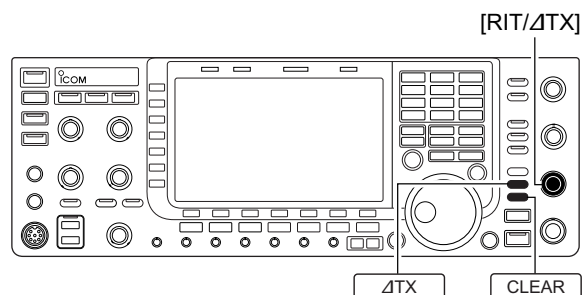

The Δ TX function shifts the transmit frequency up to ± 9.999 kHz in 1 Hz steps (10 Hz steps when cancelling the 1 Hz step readout) without moving the receive frequency.

- ① Push **[ΔTX]**.
 - "**ΔTX**" appears.
- ② Rotate **[RIT/ΔTX]**.
- ③ To reset the Δ TX frequency, push and hold **[CLEAR]** for 1 sec.
 - Push **[CLEAR]** momentarily to reset the Δ TX frequency when the quick RIT/ Δ TX clear function is ON. (p. 12-15)
- ④ To cancel the Δ TX function, push **[ΔTX]** again.
 - "**ΔTX**" disappears.

◇ Δ TX monitor function

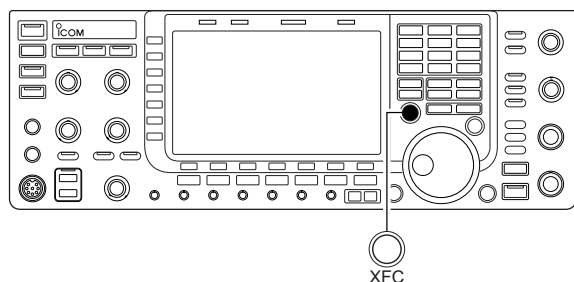

When the Δ TX function is ON, pushing and holding **[XFC]** allows you to monitor the operating frequency directly (Δ TX is temporarily cancelled).

✓ For your convenience— Calculate function

The shift frequency of the Δ TX function can be added/subtracted to the displayed frequency.

- ➔ While displaying the Δ TX shift frequency, push and hold **[ΔTX]** for 1 sec.

■ Monitor function

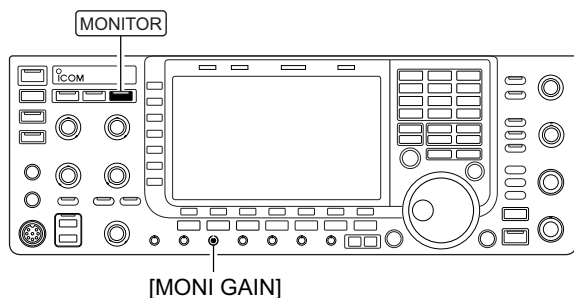

The monitor function allows you to monitor your transmit IF signals in any mode. Use this to check voice characteristics while adjusting SSB transmit parameter (p. 12-5). The CW sidetone functions regardless of the **[MONITOR]** switch setting.

- ① Push **[MONITOR]** to switch the monitor function ON and OFF.
 - **[MONITOR]** indicator above this switch lights green.
- ② Rotate **[MONI GAIN]** for the clearest audio output while pushing **[PTT]** and speaking into the microphone.

NOTE: When using the VOX voice delay, turn the monitor function OFF; or transmitted audio will be echoed.

■ Transmit filter width setting (SSB only)

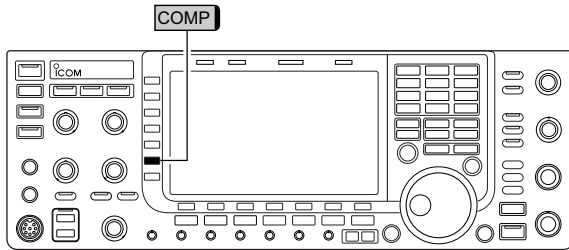

The transmit filter width for SSB mode can be selected from wide, middle and narrow.

➤ During USB or LSB mode selection, push and hold [COMP] (MF6) for 1 sec. several times to select the desired transmit filter width from wide, middle and narrow.

- The filter can be independently set on the speech compressor function is ON and OFF.

- The following filters are specified as the default. Each of the filter width can be re-set in level set mode. (p. 12-6)

WIDE	: 100 Hz to 2.9 kHz
MID	: 300 Hz to 2.7 kHz
NAR	: 500 Hz to 2.5 kHz

■ Speech compressor (SSB only)

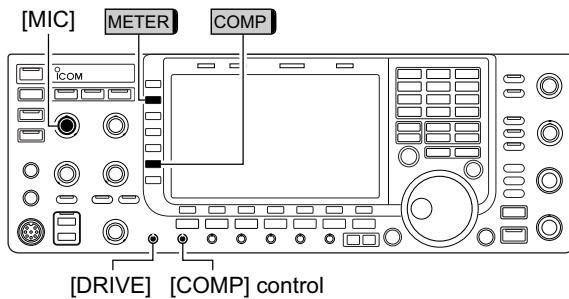

The speech compressor increases average RF output power, improving signal strength and readability in SSB mode only.

① Select USB or LSB mode and adjust [MIC] to a suitable level.

- Push [METER] (MF2) several times to select the ALC meter for microphone gain adjustment.

② Push [COMP] (MF6) to turn the speech compressor ON.

③ Push [METER] (MF2) once to select the COMP meter.

④ While speaking into the microphone, rotate [COMP] control, so that the COMP meter reads within the COMP zone (10 to 20 dB range) for your normal voice level.

⚠ When the COMP meter peaks exceed the COMP zone, your transmitted voice may be distorted.

⑤ Push [METER] (MF2) 5 times to select the ALC meter.

⑥ While speaking into the microphone, rotate [DRIVE], so that the ALC meter reads within the 30 to 50% range of the ALC zone with your normal voice level.

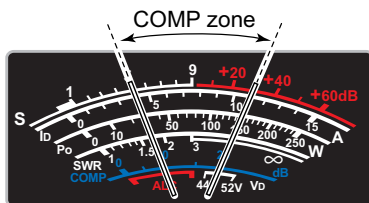

✓ For your convenience

Push and hold [METER] (MF2) for 1 sec. to display the multi-function meter that can check the ALC and COMP level at a glance.

Split frequency operation

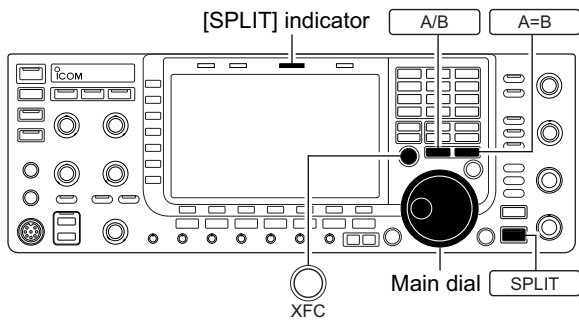

• When the split function ON



• When [XFC] is pushed



• The split frequency operation is ready



Split frequency operation allows you to transmit and receive in the same mode on two different frequencies. Split frequency operation is performed using 2 frequencies on the main and sub readouts.

The following is an example of setting 21.290 MHz for receiving and 21.310 MHz for transmitting.

- ① Set 21.290 MHz (USB) in VFO mode.
- ② Push **[SPLIT]** momentarily, then push and hold **[A=B]** for 1 sec.
 - The quick split function is much more convenient for selecting the transmit frequency. See the next section for details.
 - The equalized transmit frequency and “**SPLIT**” appear on the LCD.
 - [SPLIT] indicator lights.
 - “TX” appears to show the transmit frequency readout.
- ③ Set the transmit frequency to 21.310 MHz in the following way.
 - ➔ Rotate the main dial while pushing [XFC].
 - The transmit frequency can be monitored while pushing [XFC].
- ④ Now you can receive on 21.290 MHz and transmit on 21.310 MHz.

To change the transmit and receive frequencies, push **[A/B]** to exchange the main and sub readouts.

✓ CONVENIENT

• Direct shift frequency input

The shift frequency can be entered directly.

- ① Push **[F-INP ENT]**.
- ② Enter the desired shift frequency with the digit keys.
 - 1 kHz to 1 MHz can be set.
 - When you require a negative shift direction, push **[GENE .]** in advance.
- ③ Push **[SPLIT]**.
 - The shift frequency is input in the sub readout and the split function is turned ON.

[Example]

To transmit on 1 kHz higher frequency:

- Push **[F-INP ENT]**, **[1.8]** **[1]** then **[SPLIT]**.

To transmit on 3 kHz lower frequency:

- Push **[F-INP ENT]**, **[GENE .]**, **[7]** **[3]** then **[SPLIT]**.

• Split lock function

Accidentally releasing [XFC] while rotating the main dial changes the receive frequency. To prevent this, use both the split lock and dial lock functions to change the transmit frequency only. The split lock function cancels the dial lock function while pushing [XFC] during split frequency operation.

The dial lock's effect during split frequency operation can be selected in the set mode for both receive and transmit frequencies; or only the receive frequency. (p. 12-13)

■ Quick split function

When you find a DX station, an important consideration is how to set the split frequency.

When you push and hold the [SPLIT] switch for 1 sec., split frequency operation is turned ON and the transmit frequency is equalized to the received frequency.

This shortens the time needed to begin split frequency operation.

The quick split function is ON by default. For your convenience, it can be turned OFF in Others set mode. (p. 12-12) In this case, the [SPLIT] switch does not equalize the transmit frequency to the receive frequency.

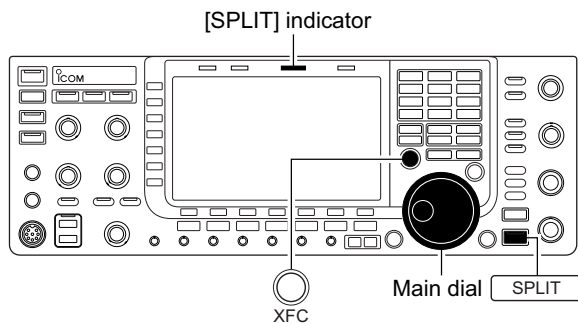

- ① Suppose you are operating at 21.290 MHz (USB) in VFO mode.
- ② Push and hold [SPLIT] for 1 sec.
 - Split frequency operation is turned ON.
 - The transmit frequency (unselected VFO's readout) is equalized to the receive frequency (selected VFO's readout).
 - "F-INP" indicator appears.
- ③ Enter the desired offset frequency from the keypad then push [SPLIT], or set the transmit frequency with the main dial while pushing [XFC].
 - "F-INP" indicator appears when [F-INP ENT] is pushed.
 - Offset frequency setting with the keypad— example
 - To transmit on 1 kHz higher frequency:
 - Push [F-INP ENT], [1.8], [1] then [SPLIT].
 - To transmit on 3 kHz lower frequency:
 - Push [F-INP ENT], [GENE .], [7], [3] then [SPLIT].

◇ Split lock function

The split lock function is convenient for changing only the transmit frequency. When the split lock function is not used, accidentally releasing [XFC] while rotating the main dial, changes the receive frequency. The split lock function is ON by default, but can be turned OFF in set mode. (p. 12-13)

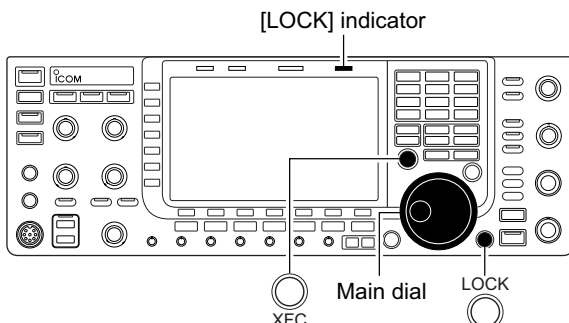

- ① While split frequency operation is ON, push [LOCK] to activate the split lock function.
- ② While pushing [XFC], rotate the main dial to change the transmit frequency.
 - If you accidentally release [XFC] while rotating the main dial, the receive frequency does NOT change.

■ About digital voice recorder	7-2
■ Recording a received audio	7-3
◇ Basic recording	7-3
◇ One-touch recording	7-3
■ Playing the recorded audio	7-4
◇ Basic playing	7-4
◇ One-touch playing	7-4
■ Protect the recorded contents	7-5
■ Erasing the recorded contents	7-5
■ Recording a message for transmit	7-6
◇ Recording	7-6
◇ Confirming a message for transmit	7-6
■ Programming a memory name	7-7
■ Sending a recorded message	7-8
◇ Transmit level setting	7-8
■ Voice set mode	7-9
■ Saving a voice message into the USB-Memory	7-10
◇ Saving the received audio memory	7-10
◇ Saving the TX memory	7-10

■ About digital voice recorder

The IC-7700 has digital voice memories, up to 4 messages for transmit, and up to 20 messages for receive. A maximum message length of 30 sec. can be recorded into receive memory (total message length for all channels of up to 209 sec.) and a total message length of up to 99 sec. can be recorded in transmit memory.

The transmit memory is very convenient for repeated CQ and exchange transmissions in contests, as well as when making consecutive calls to DXpeditions.

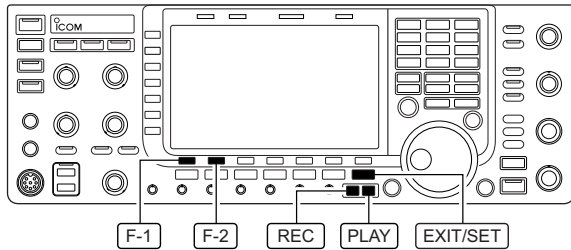

- ① Select any mode.
- ② Push [VOICE] [F-2] to display voice recorder screen.
- ③ Push [EXIT/SET] to display voice recorder menu.
- ④ Push [PLAY] [F-1] or [MIC REC] [F-2] to select the desired memory channel screen, then record audio or playback the contents as described below.
- ⑤ Push [EXIT/SET] twice to exit voice recorder screen.

• Example— When [REC] is pushed and held for 1 sec.

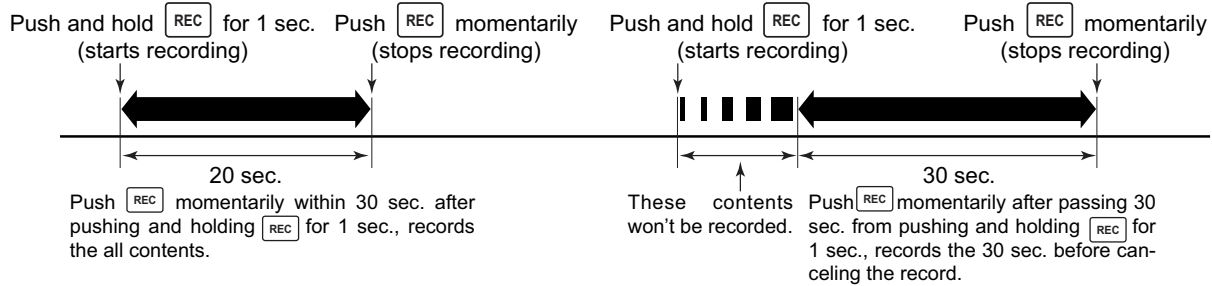

• Example— When [REC] is pushed momentarily

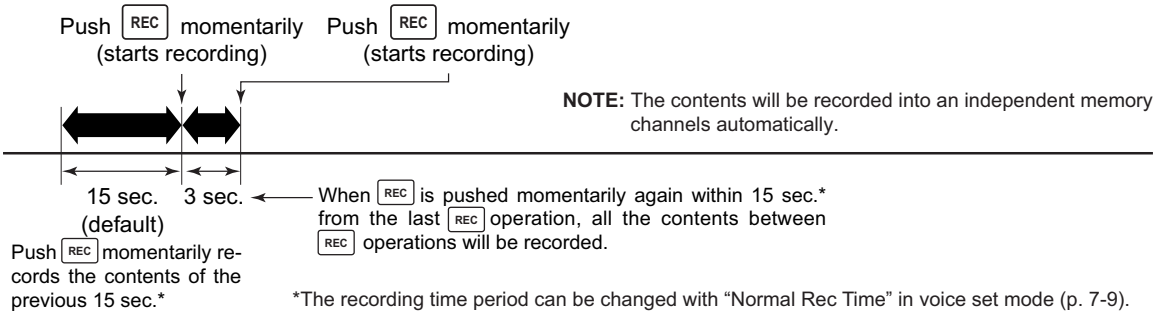

• Playing back the all contents in a channel

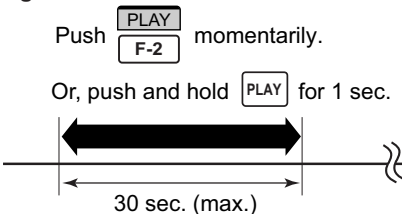

• Playing back the end of 5 sec.* in a channel

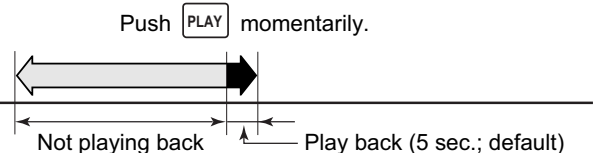

*The playing back time period can be changed with "Short Play Time" in voice set mode (p. 7-9).

Recording a received audio

Up to 20 receive voice memories are available in the IC-7700. A total audio length of up to 209 sec. can be recorded in receive messages. However, the maximum recordable length into a single message is 30 sec.

This voice recorder records not only the received audio, but also the information such as set operating frequency, mode, and the recording time for your future reference.

Basic recording

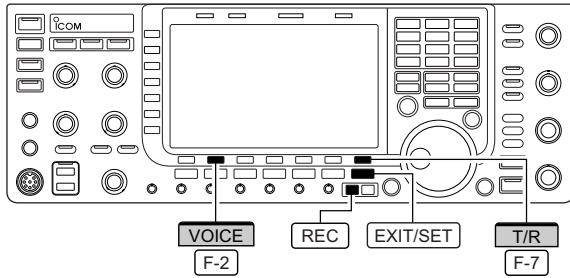

- ① Push [EXIT/SET] several times to close a multi-function screen, if necessary.
- ② Select the desired mode.
- ③ Push [VOICE] [F-2] to call up the voice recorder screen.
 - Previously selected screen, TX or RX memory, is displayed. If the TX memory channel (T1–T4) appears, push [T/R] [F-7] to select RX memory channel.
- ④ Push and hold [REC] for 1 sec. to start recording.
 - The operating frequency, mode and current time are programmed as the memory names automatically.
- ⑤ Push [REC] momentarily to stop recording.

IMPORTANT!

Push [REC] to stop recording before, or when 30 sec. has passed from the start of recording. The voice recorder memory records the 30 sec. (max.) of audio before [REC] is pushed. For example, when recording 40 sec. of audio, the first 10 sec. audio will be over-written with the last 10 sec., so that the total of audio recorded is only 30 sec. When you record the 21st audio message, or when the total audio length exceeds 209 sec., the oldest recorded audio is automatically erased to make room for the new audio.

- ⑥ Push [EXIT/SET] twice to exit the voice recorder screen.

NOTE: When transmit (or [PTT] is pushed) while recording, no audio will be recorded.

One-touch recording

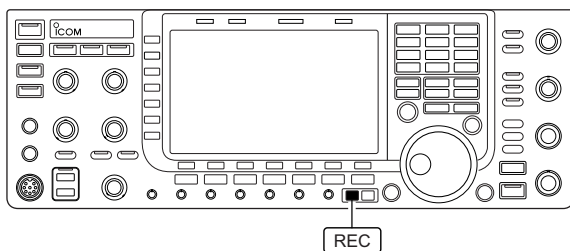

To record the received signal immediately, one-touch voice recording is available.

- ➡ Push [REC] momentarily to record the previous 15 sec. audio.
 - The recordable time period can be set in voice set mode. (p. 7-9)

■ Playing the recorded audio

◇ Basic playing

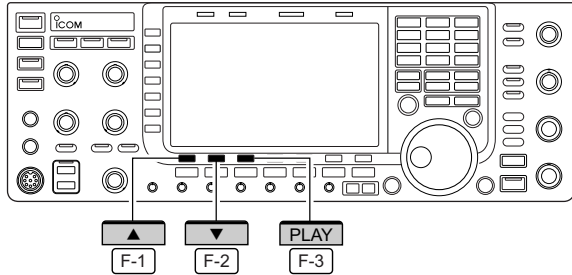

- ① Push [EXIT/SET] several times to close a multi-function screen, if necessary.
- ② Push [VOICE] [F-2] to call up the voice recorder screen.
 - Previously selected screen, TX or RX memory, is displayed. If the TX memory message (T1–T4) appears, push [T/R] [F-7] to select RX memory message.
- ③ Push [▲] [F-1] or [▼] [F-2] to select the desired voice memory to playback.
- ④ Push [PLAY] [F-3] to start playback.
 - “▶PLAY” indicators appear and the timer counts down.
- ⑤ Push [PLAY] [F-3] again to stop playback if desired.
 - Playback is terminated automatically when all of the recorded contents in the message are played, or after 30 sec.
- ⑥ Push [EXIT/SET] twice to exit the voice recorder screen.

◇ One-touch playing

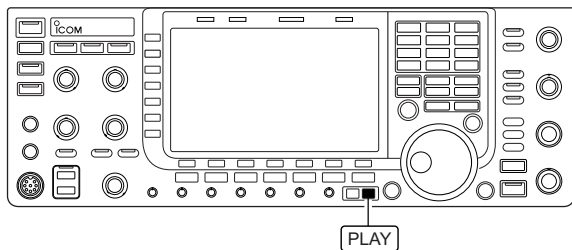

The previously recorded audio in message 1 can be played back without selecting voice recorder screen.

- ➡ Push [PLAY] momentarily to play back the last 5 sec. of the previously recorded audio.
 - “▶PLAY” indicator appears.
 - Playback is terminated automatically when all of the recorded contents in the message are played, or after 5 sec.
 - The playback time period can be set in voice set mode. (p. 7-9)

■ Protect the recorded contents

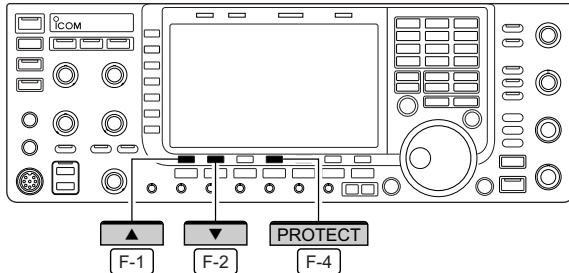

The protect function is available to protect the recorded contents from accidental erasure, such as over-writing, etc.

- ① Call up the voice recorder screen, RX memory.
- ② Push [▲] [F-1] or [▼] [F-2] to select the desired voice message.
- ③ Push [PROTECT] [F-4] to turn the protect function ON and OFF.
 - “” indicator appears when the contents is protected.
- ④ Push [EXIT/SET] twice to exit the voice recorder screen.

■ Erasing the recorded contents

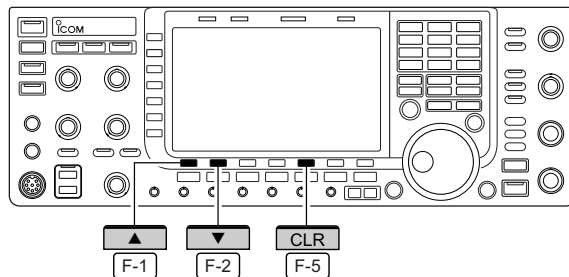

The recorded contents can be erased independently by message.

- ① Call up the voice recorder screen, RX memory.
- ② Push [▲] [F-1] or [▼] [F-2] to select the desired voice message to be erased.
- ③ Push and hold [CLR] [F-5] for 1 sec. to erase the contents.
 - Push [PROTECT] [F-4] to release the protection in advance if necessary.
- ④ Push [EXIT/SET] twice to exit the voice recorder screen.

Recording a message for transmit

To transmit a message using the voice recorder, record the desired message in advance as described below. The IC-7700 has digital voice memories for transmission, up to 4 messages and a total message length of up to 99 sec. can be recorded.

Recording

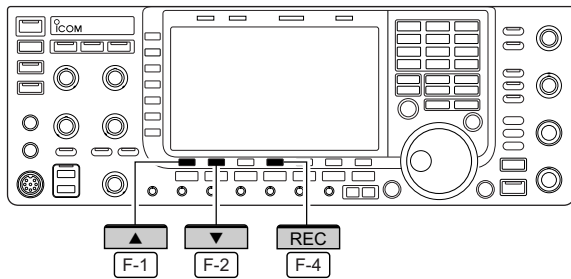

Appears

Adjust [MIC] control so that this indicator reads within 100%.

- ① Push [EXIT/SET] several times to close a multi-function screen, if necessary.
- ② Push [VOICE] [F-2] to call up the voice recorder screen.
- ③ Push [EXIT/SET] to select voice recorder menu.
- ④ Push [MIC REC] [F-2] to select the voice mic. record screen.
- ⑤ Push [▲] [F-1] or [▼] [F-2] to select the desired message.
- ⑥ Push and hold [REC] [F-4] for 1 sec. to start recording.
 - “REC” indicator appears.
 - Speak into the microphone without pushing [PTT].
 - Previously recorded contents are cleared.
 - Audio output from the internal speaker is automatically muted.
- ⑦ While speaking into the microphone with your normal voice level, adjust the [MIC] control so that the [MIC-REC LEVEL] indicator reads within 100%.
- ⑧ Push [REC] [F-4] momentarily to stop recording.
 - The recording is terminated automatically when the remaining time becomes 0 sec.
- ⑨ Push [EXIT/SET] twice to exit the voice recorder screen.

Confirming a message for transmit

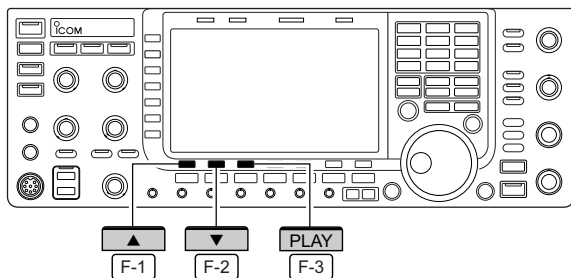

- ① Perform the steps ① to ④ as “Recording” above.
- ② Push [▲] [F-1] or [▼] [F-2] to select the desired message.
- ③ Push [PLAY] [F-3] to playback the recorded contents.
 - “PLAY” indicator appears.
- ④ Push [PLAY] [F-3] again to stop playback.
 - Playback is terminated automatically when all of the recorded contents in the message are played.
- ⑤ Push [EXIT/SET] twice to exit the voice recorder screen.

■ Programming a memory name

Memory messages can be tagged with alphanumeric names of up to 20 characters each.

Capital letters, small letters, numerals, some symbols (! # \$ % & ¥ ? “ ` ^ + - * / . , ; = < > () [] { } | _ ~ @) and spaces can be used. (See the table below.)

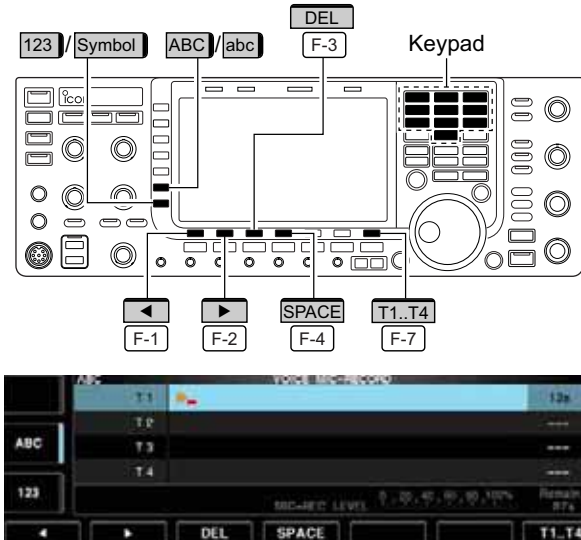

• Voice memory name editing example



- ① Record a message as described in page 7-6.
- ② During the voice mic. record screen indication, push [NAME] [F-5] to enter memory name edit condition.
 - A cursor appears and blinks.
- ③ Push [T1..T4] [F-7] several times to select the desired voice message.
- ④ Input the desired character by rotating the main dial or by pushing the band key for number input.
 - Push [ABC] (MF6) or [abc] (MF6) to toggle capital and small letters.
 - Push [123] (MF7) or [Symbol] (MF7) to toggle numerals and symbols.
 - Push [◀] [F-1] or [▶] [F-2] for cursor movement.
 - Push [DEL] [F-3] to delete the selected character.
 - Push [SPACE] [F-4] to input a space.
 - Pushing the transceiver's keypad, [0]–[9], can also enter numerals.
- ⑤ Push [EXIT/SET] to input and set the name.
 - The cursor disappears.
- ⑥ Repeat steps ③ to ⑤ to program another voice message's name, if desired.
- ⑦ Push [EXIT/SET] twice to exit the voice recorder screen.

• Usable characters

Key selection	Editable characters
ABC	A to Z (capital letters)
abc	a to z (small letters)
123	0 to 9 (numerals)
Symbol	! # \$ % & ¥ ? “ ` ^ + - * / . , ; = < > () [] { } _ ~ @

■ Sending a recorded message

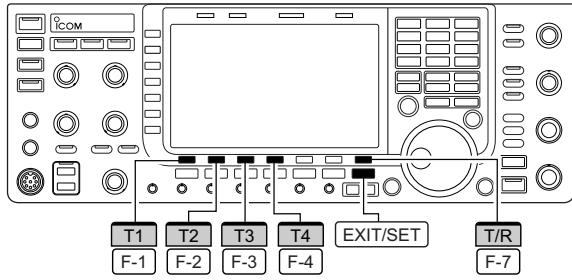

Appears

Counts down

- ① Push [EXIT/SET] several times to close a multi-function screen, if necessary.
- ② Select a phone mode by pushing [SSB] or [AM/FM].
- ③ Push [VOICE] [F-2] to call up the voice recorder screen.
 - If the receive voice message appears, push [T/R] [F-7] to select TX message (T1–T4).
- ④ Push the desired message switch, [T1] [F-1] to [T4] [F-4], momentarily to transmit the contents.
 - The transceiver transmits automatically.
 - “SEND” indicator appears and the memory timer counts down.
 - You hear the transmitted message from the speaker as the default. This can be turned OFF in voice set mode. (p. 7-9)
- ⑤ Push the selected message switch, [T1] [F-1] to [T4] [F-4], again to stop, if desired.
 - The transceiver returns to receive automatically when all of the recorded contents in the message are transmitted.
- ⑥ Push [EXIT/SET] twice to exit the voice memory screen.

✓ For your information

When an external keypad is connected to [EXT KEY-PAD], the recorded message, T1–T4, can be transmitted without opening the voice recorder screen. See page 2-7 for details.

◇ Transmit level setting

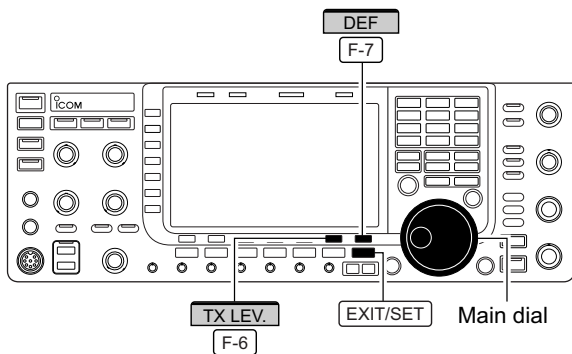

- ① Call up the voice recorder screen as described as above.
- ② Push [TX LEV.] [F-6] to select the voice memory transmit level set condition.
- ③ Push the desired message switch, [T1] [F-1] to [T4] [F-4], momentarily to transmit the contents.
 - The transceiver transmits automatically.
 - “SEND” indicator appears and the memory timer counts down.
- ④ Rotate the main dial to adjust the transmit voice level.
 - Push and hold [DEF] [F-7] for 1 sec. to select the default condition.
- ⑤ Push [EXIT/SET] to return to the voice recorder screen.

■ Voice set mode

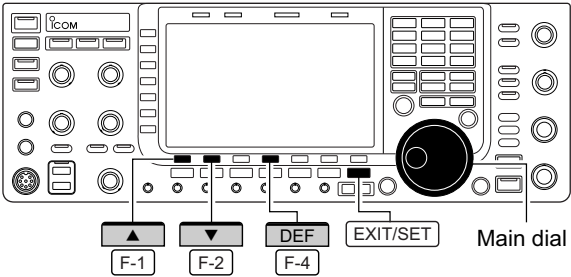

Sets the automatic monitor function, short play and normal recording times for voice recorder.

- ① Push **EXIT/SET** several times to close a multi-function screen, if necessary.
- ② Push **[VOICE] [F-2]** to call up the voice recorder screen.
- ③ Push **EXIT/SET** to select voice recorder menu.
- ④ Push **[SET] [F-7]** to select voice set mode screen.
- ⑤ Push **[▲] [F-1]** or **[▼] [F-2]** to select the desired item.
- ⑥ Rotate the main dial to set the desired condition or value.
 - Push and hold **[F-4•DEF] [F-4]** for 1 sec. to select the default condition or value.
- ⑦ Push **EXIT/SET** to exit the voice set mode screen.

Auto Monitor	ON
Turn the automatic monitor function for recorded audio contents transmission.	<ul style="list-style-type: none"> • ON : Monitors transmitting audio automatically when sending a recorded audio. • OFF : Monitors transmitting audio only when the monitor function is in use.
Short Play Time	5s
Set the desired time period for the one-touch playing (when PLAY is pushed momentarily).	<ul style="list-style-type: none"> • 3 to 10 sec. in 1 sec. steps can be set. (default: 5 sec.)
Normal Rec Time	15s
Set the desired time period for the for one-touch recording (when REC is pushed momentarily).	<ul style="list-style-type: none"> • 5 to 15 sec. in 1 sec. steps can be set. (default: 15 sec.)

■ Saving a voice message into the USB-Memory

◇ Saving the received audio memory

The USB-Memory is not supplied by Icom.

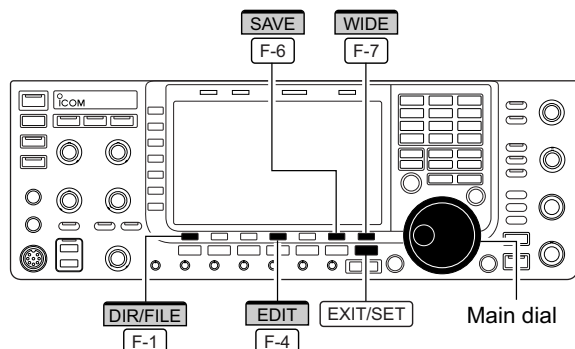

• Voice recorder RX memory screen



• Voice file save screen— file name edit

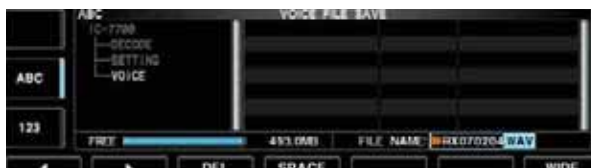

• While saving



The recorded RX memory contents can be saved into the USB-Memory.

- ① During voice recorder RX memory screen display, push [SAVE] [F-6] to select voice file save screen.
 - Previously selected screen, TX or RX memory, is displayed. If the TX message (T1–T4) appears, push [T/R] [F-7] to select RX message.

- ② Change the following conditions if desired.

• File name:

- ① Push [EDIT] [F-4] to select file name edit condition.
 - Push [DIR/FILE] [F-1] several times to select the file name, if necessary.
- ② Push [ABC] (MF6), [123] (MF7) or [Symbol] (MF7) to select the character group, then rotate the main dial to select the character.
 - [ABC] (MF6): A to Z (capital letters); [123] (MF7): 0 to 9 (numerals); [Symbol] (MF7): ! # \$ % & ' ` ^ + - = () [] { } ~ @ can be selected.
 - Push [◀] [F-1] to move the cursor left, push [▶] [F-2] to move the cursor right, push [DEL] [F-3] to delete a character and push [SPACE] [F-4] to insert a space.
- ③ Push [EXIT/SET] to set the file name.

• Saving location



- ① Push [DIR/FILE] [F-1] to select tree view screen.
- ② Select the desired directory or folder in the USB-Memory.
 - Push [◀▶] [F-4] to select the upper directory.
 - Push [▲] [F-2] or [▼] [F-3] to select folder in the same directory.
 - Push and hold [◀▶] [F-4] for 1 sec. to select a folder in the directory.
 - Push [REN/DEL] [F-5] to rename the folder.
 - Push and hold [REN/DEL] [F-5] for 1 sec. to delete the folder.
 - Push and hold [MAKE] [F-6] for 1 sec. to making a new folder. (Edit the name with the same manner as the “• File name” above.)

- ③ Push [DIR/FILE] [F-1] twice to select the file name.

- ③ Push [SAVE] [F-6].
 - After the saving is completed, return to voice recorder RX memory screen automatically.

◇ Saving the TX memory

The TX memory contents can also be saved into the USB-Memory. However, the contents are saved with the message list, set mode conditions, etc. at the same time. See page 12-22 for details.

■ Memory channels	8-2
■ Memory channel selection	8-2
◇ Using the  /  keys	8-2
◇ Using the keypad	8-2
■ Memory channel programming	8-3
◇ Programming in VFO mode	8-3
◇ Programming in memory mode	8-3
■ Frequency transferring	8-4
◇ Transferring in VFO mode	8-4
◇ Transferring in memory mode	8-4
■ Memory list screen	8-5
◇ Selecting a memory channel using the memory list screen	8-5
◇ Confirming programmed memory channels	8-5
■ Memory names	8-6
◇ Editing (programming) memory names	8-6
■ Memory clearing	8-6
■ Memo pads	8-7
◇ Writing frequencies and operating modes into memo pads	8-7
◇ Calling up a frequency from a memo pad	8-7

Memory channels

The transceiver has 101 memory channels. Memory mode is very useful for quickly changing to often-used frequencies.

All 101 memory channels are tunable which means the programmed frequency can be tuned temporarily with the main dial, etc. in memory mode.

MEMORY CHANNEL	MEMORY CHANNEL NUMBER	CAPABILITY	TRANSFER TO VFO	OVER-WRITING	CLEAR
Regular memory channels	1–99	One frequency and one mode in each memory channel.	Yes	Yes	Yes
Scan edge memory channels	P1, P2	One frequency and one mode in each memory channel as scan edges for programmed scan.	Yes	Yes	No

Memory channel selection

Using the ▲ / ▼ keys

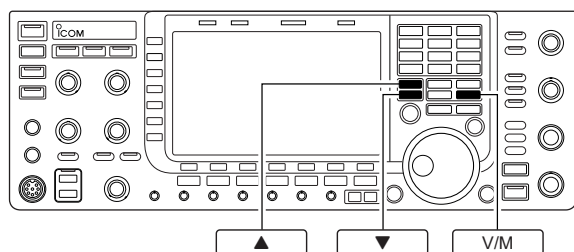

- ① Push **V/M** to select memory mode.
- ② Push **▲** / **▼** several times to select the desired memory channel.
 - Push and hold **▲** / **▼** for continuous selection.
 - [UP] and [DN] on the microphone can also be used.
- ③ To return to VFO mode, push **V/M** again.

Using the keypad

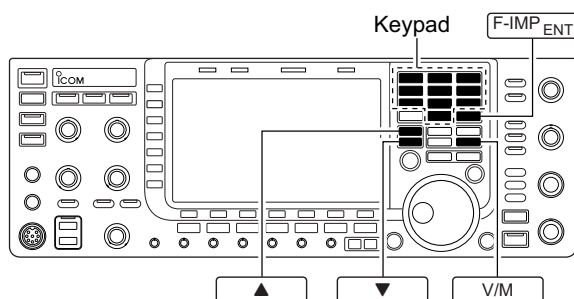

- ① Push **V/M** to select memory mode.
- ② Push **F-IMP ENT**.
- ③ Push the desired memory channel number using the keypad.
 - Enter 100 or 101 to select scan edge channel P1 or P2, respectively.
- ④ Push **▲** or **▼** to select the desired memory channel.

[EXAMPLE]

- To select the memory channel 3;
 - Push **F-IMP ENT**, **7** **3**, then push **▲** or **▼**.
- To select the memory channel 12;
 - Push **F-IMP ENT**, **1.8** **1**, **3.5** **2**, then push **▲** or **▼**.
- To select the scan edge channel P1;
 - Push **F-IMP ENT**, **1.8** **1**, **50** **0**, **50** **0**, then push **▲** or **▼**.
- To select the scan edge channel P2;
 - Push **F-IMP ENT**, **1.8** **1**, **50** **0**, **1.8** **1**, then push **▲** or **▼**.

Memory channel programming

Memory channel programming can be performed either in VFO mode or in memory mode.

Programming in VFO mode

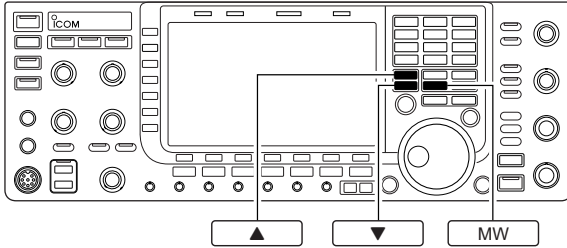

[EXAMPLE]:

Programming 7.088 MHz/LSB into memory channel 12.

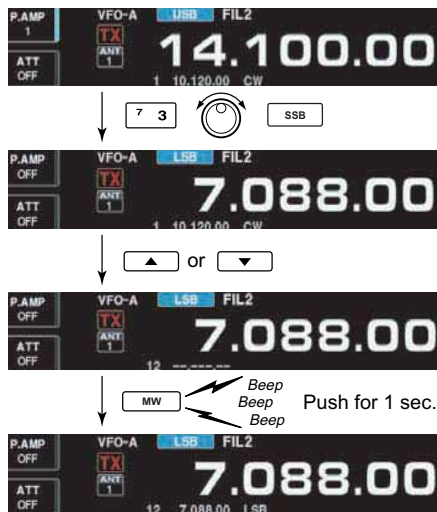

- ① Set the desired frequency, operating mode and filter width in VFO mode.
- ② Push \blacktriangle / \blacktriangledown several times to select the desired memory channel.
 - Memory list screen is convenient for selecting the desired channel.
 - Memory channel contents appear in the memory channel readout (below the frequency readout).
 - “--:--:--” appears if the selected memory channel is a blank channel (and does not have contents).
- ③ Push and hold MW for 1 sec. to program the displayed frequency, operating mode, etc., into the memory channel.

Programming in memory mode

[EXAMPLE]:

Programming 21.280 MHz/USB into memory channel 18.

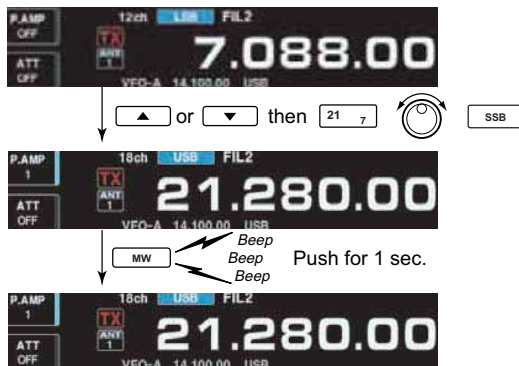

- ① Select the desired memory channel with \blacktriangle / \blacktriangledown in memory mode.
 - Memory channel contents appear in the memory channel readout (below the frequency readout).
 - “--:--:--” appears if the selected memory channel is a blank channel (and does not have contents).
- ② Set the desired frequency and operating mode in memory mode.
 - To program a blank channel, use direct frequency entry with the keypad or memo pads, etc.
- ③ Push and hold MW for 1 sec. to program the displayed frequency and operating mode into the memory channel.

■ Frequency transferring

◇ Transferring in VFO mode

TRANSFERRING EXAMPLE IN VFO MODE
 Operating frequency : 21.320 MHz/USB (VFO)
 Contents of M-ch 16 : 14.018 MHz/CW

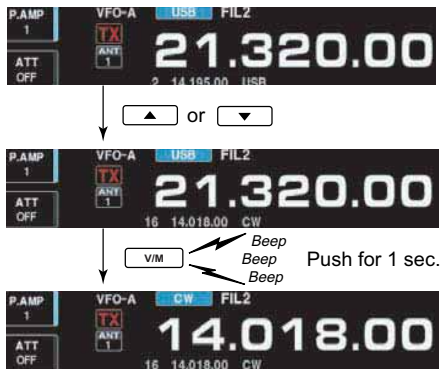

◇ Transferring in memory mode

TRANSFERRING EXAMPLE IN MEMORY MODE
 Operating frequency : 21.320 MHz/USB (M-ch 16)
 Contents of M-ch 16 : 14.018 MHz/CW

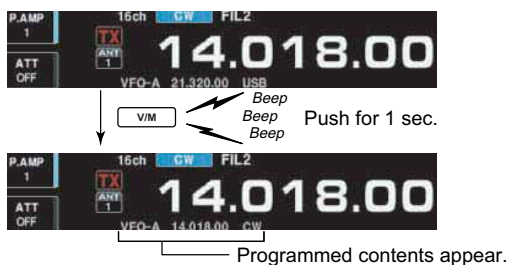

The frequency and operating mode in a memory channel can be transferred to the VFO. Frequency transferring can be performed in either VFO mode or memory mode.

This is useful for transferring programmed contents to a VFO.

- ① Select VFO mode with .
- ② Select the memory channel to be transferred with / .
 - Memory list screen is convenient for selecting the desired channel.
 - Memory channel contents appear in the memory channel readout (below the frequency readout).
 - "--:--:--" appears if the selected memory channel is a blank channel. In this case transferring is not possible.
- ③ Push and hold for 1 sec. to transfer the frequency and operating mode.
 - Transferred frequency and operating mode appear on the frequency readout.

This is useful for transferring frequency and operating mode while operating in memory mode.

- When you have changed the frequency or operating mode in the selected memory channel:
 - **Displayed** frequency, mode and filter setting are transferred.
 - **Programmed** frequency and mode in the memory channel are not transferred, and they remain in the memory channel.

- ① Select the memory channel to be transferred with / in memory mode.
 - And, set the frequency or operating mode if required.
- ② Push and hold for 1 sec. to transfer the frequency and operating mode.
 - Displayed frequency and operating mode are transferred to the VFO.
- ③ To return to VFO mode, push momentarily.

Memory list screen

The memory list screen simultaneously shows 9 memory channels and their programmed contents. 15 memory channels can be displayed in the wide memory list screen.

You can select a desired memory channel from the memory list screen.

Selecting a memory channel using the memory list screen

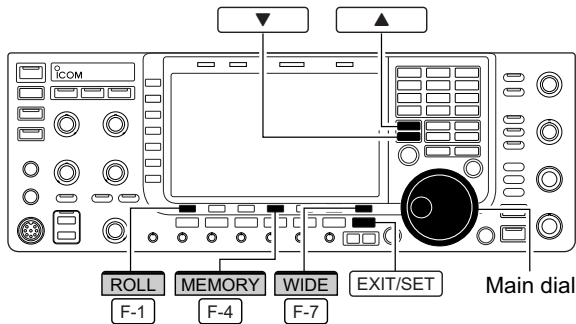

- ① Push [EXIT/SET] several times to close a multi-function screen, if necessary.
- ② Push [MEMORY] [F-4] to select memory list screen.
 - [WIDE] [F-7] switches the standard and wide screens.
- ③ While pushing and holding [ROLL] [F-1], rotate the main dial to select the desired memory channel.
 - ▲ and ▼ can also be used.
- ④ Push [EXIT/SET] to exit memory list screen.

Memory list screen



Confirming programmed memory channels

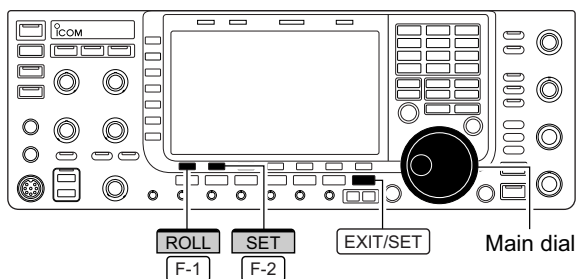

- ① Select memory list screen as described above.
- ② While pushing [ROLL] [F-1], rotate the main dial to scroll the screen.
- ③ Push [SET] [F-2] to select the highlighted memory channel, if desired.
 - “▶” appears beside the selected memory channel number in the memory list screen and the selected memory channel contents are displayed below the frequency readout.
- ④ Push [EXIT/SET] to exit memory list screen.

Memory names

All memory channels (including scan edges) can be tagged with alphanumeric names of up to 10 characters each.

Capital letters, small letters, numerals, some symbols (! # \$ % & ¥ ? " ' ` ^ + - * / . , ; = < > () [] { } | _ ~ @) and spaces can be used.

Editing (programming) memory names

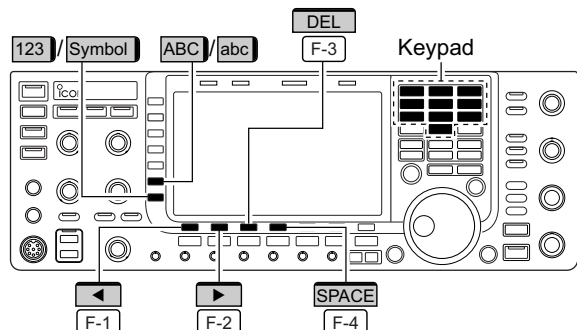

- ① Push [EXIT/SET] several times to close a multi-function screen, if necessary.
- ② Push [MEMORY] [F-4] to select memory list screen.
- ③ Select the desired memory channel.
- ④ Push [NAME] [F-4] to edit memory channel name.
 - A cursor appears and blinks.
 - Memory channel names of blank channels cannot be edited.
- ⑤ Input the desired character by rotating the main dial or by pushing the keypad for number input.
 - Push [ABC] or [abc] to toggle capital and small letters.
 - Push [123] or [Symbol] to toggle numerals and symbols.
 - Push [◀] [F-1] or [▶] [F-2] for cursor movement.
 - Push [DEL] [F-3] to delete the selected character.
 - Push [SPACE] [F-4] to input a space.
 - Pushing the transceiver's keypad, [0]–[9], can also enter numerals.
- ⑥ Push [EXIT/SET] to input and set the name.
 - The cursor disappears.
- ⑦ Repeat steps ③ to ⑥ to program another memory channel's name, if desired.
- ⑧ Push [EXIT/SET] to exit memory list screen.

Memory clearing

Any unused memory channels can be cleared. The cleared memory channels become blank channels.

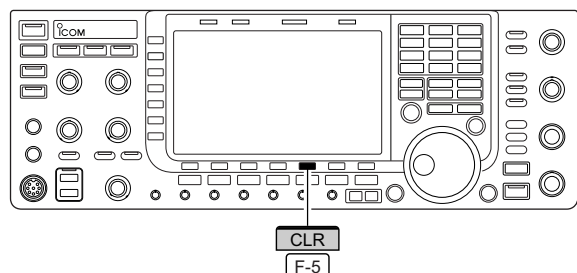

- ① Select memory mode with [V/M].
- ② Push [MEMORY] [F-4] to select memory list screen.
- ③ Select the desired memory channel with [▲] / [▼].
- ④ Push and hold [CLR] [F-5] for 1 sec. to clear the contents.
 - The programmed frequency and operating mode disappear.
- ⑤ To clear other memory channels, repeat steps ③ and ④.

■ Memo pads

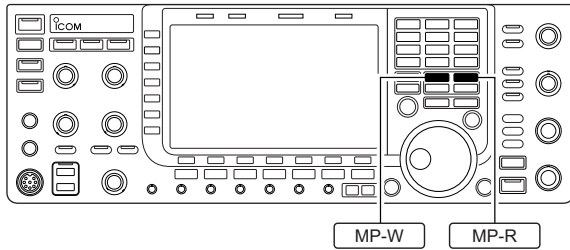

The transceiver has a memo pad function to store frequency and operating mode for easy write and recall. The memo pads are separate from memory channels.

The default number of memo pads is 5, however, this can be increased to 10 in set mode if desired. (p. 12-15)

Memo pads are convenient when you want to memorize a frequency and operating mode temporarily, such as when you find a DX station in a pile-up, or when a desired station is busy for a long time and you want to temporarily search for other stations.

Use the transceiver's memo pads instead of relying on hastily scribbled notes that are easily misplaced.

◇ Writing frequencies and operating modes into memo pads

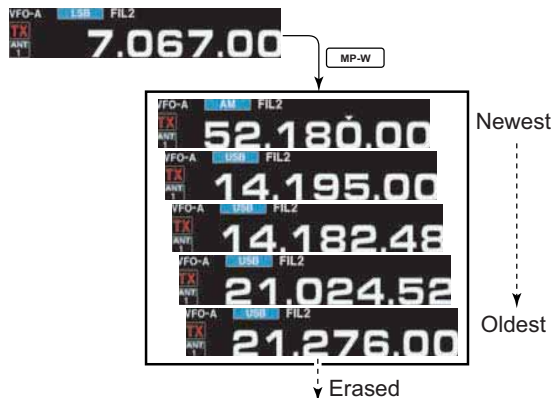

In this example, 21.276 MHz (USB) will be erased when 7.067 MHz (LSB) is written.

You can store the readout frequency and operating mode by pushing **MP-W**.

When you store a 6th frequency and operating mode, the oldest stored frequency and operating mode are automatically erased to make room for the new settings.

Each memo pad must have its own unique combination of frequency and operating mode; memo pads having identical settings cannot be written.

◇ Calling up a frequency from a memo pad

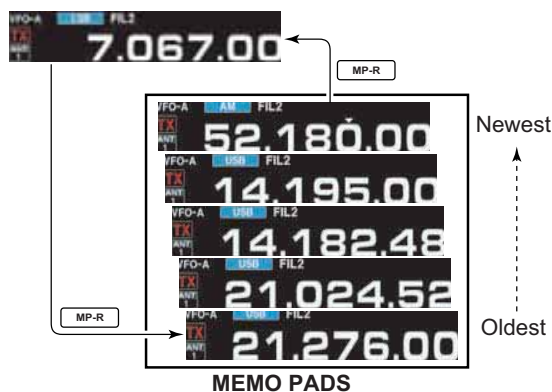

You can call up the desired frequency and operating mode of a memo pad by pushing **MP-R** several times.

- Both VFO and memory modes can be used.
- The frequency and operating mode are called up, starting from the most recently written.

When you call up a frequency and an operating mode from memo pads with **MP-R**, the previously displayed frequency and operating mode are automatically stored in a temporary pad. The frequency and operating mode in the temporary pad can be recalled by pushing **MP-R** several times.

You may think there are 6 memo pads because 6 different frequencies (5 are in memo pads and 1 is in the temporary pad) are called up by **MP-R**.

If you change the frequency or operating mode called up from a memo pad with the main dial, etc., the frequency and operating mode in the temporary pad are erased.

- Scan types 9-2
- Preparation 9-2
- Voice squelch control function 9-3
- Scan set mode 9-3
- Programmed scan operation 9-4
- ΔF scan operation 9-4
- Fine programmed scan/Fine ΔF scan 9-5
- Memory scan operation 9-6
- Select memory scan operation 9-6
- Setting select memory channels 9-7
 - ◇ Setting in scan screen 9-7
 - ◇ Setting in memory list screen 9-7
 - ◇ Erasing the select scan setting 9-7
- Tone scan 9-8

■ Scan types

- The scan function can be used on the main read-out only.
- You can operate a scan while operating on a frequency using the split functions.

PROGRAMMED SCAN

Repeatedly scans between two scan edge frequencies (scan edge memory channels P1 and P2).

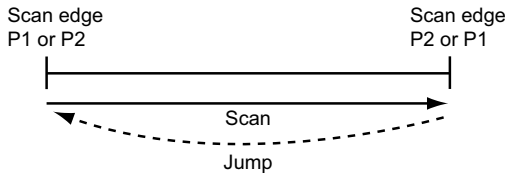

This scan operates in VFO mode.

ΔF SCAN

Repeatedly scans within ΔF span area.

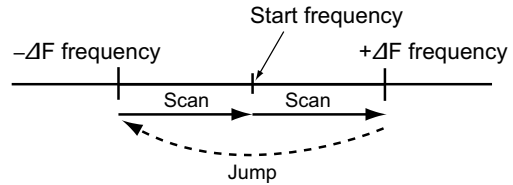

This scan operates in both VFO and memory modes.

MEMORY SCAN

Repeatedly scans all programmed memory channels.

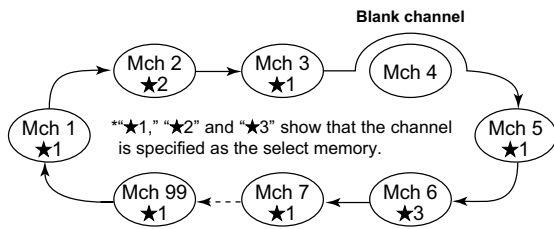

This scan operates in memory mode.

SELECT MEMORY SCAN

Repeatedly scans all or one of 3 select memory channels.

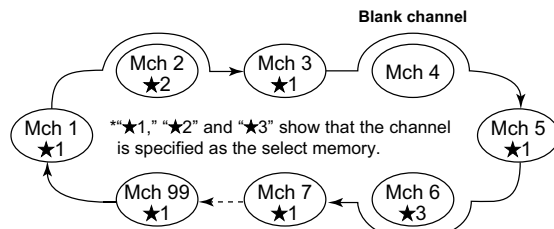

This scan operates in memory mode.

■ Preparation

• Channels

For programmed scan:

Program scan edge frequencies into scan edge memory channels P1 and P2.

For ΔF scan:

Set the ΔF span (ΔF scan range) in the scan screen.

For memory scan:

Program 2 or more memory channels except scan edge memory channels.

For select memory scan:

Designate 2 or more memory channels as select memory channels. To designate the channel as a select memory channel, choose a memory channel, then push [SELECT] F-3 in the scan screen (memory mode) or in the memory list screen.

• Scan resume ON/OFF

You can select the scan to resume or cancel when detecting a signal in set mode. Scan resume ON/OFF must be set before operating a scan. See p. 9-3 for ON/OFF setting and scan resume condition details.

• Scan speed

Scan speed can be selected from 2 levels, high or low, in scan set mode. See p. 9-3 for details.

• Squelch condition

SCAN STARTS WITH	PROGRAMMED SCAN	MEMORY SCAN
SQUELCH OPEN	The scan continues until it is stopped manually, and does not pause even if it detects signals.	Scan pauses on each channel when the scan resume is ON; not applicable when OFF.
SQUELCH CLOSED	Scan stops when detecting a signal. If you set scan resume ON in set mode, the scan pauses for 10 sec. when detecting a signal, then resumes. When a signal disappears while scan is paused, scan resumes 2 sec. later.	

■ Voice squelch control function

This function is useful when you don't want unmodulated signals pausing or cancelling a scan. When the voice squelch control function is activated, the transceiver checks received signals for voice components.

If a received signal includes voice components, and the tone of the voice components changes within 1 sec., scan pauses (or stops). If the received signal includes no voice components or the tone of the voice components does not change within 1 sec., scan resumes.

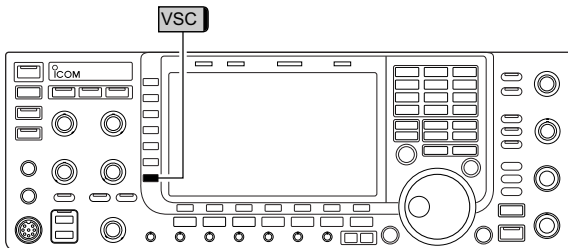

➔ While a phone mode (SSB, AM or FM) is selected, push [VSC] (MF7) to switch the VSC (Voice Squelch Control) function ON and OFF.

- "VSC" appears when the function is activated.

- The VSC function activates for any scan.
- The VSC function resumes the scan on unmodulated signals, regardless of whether the scan resume condition is set to ON or OFF.

■ Scan set mode

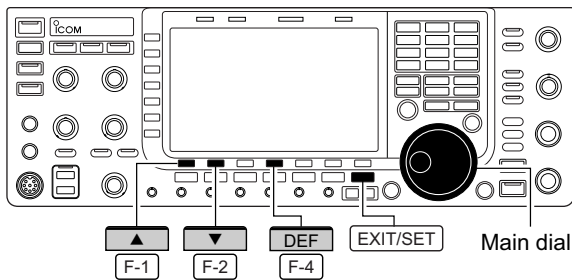

When the squelch is open, scan continues until it is stopped manually—it does not pause on detected signals. When squelch is closed, scan stops when detecting a signal, then resumes according to the scan resume condition. Scan speed and the scan resume condition can be set using the scan set mode.

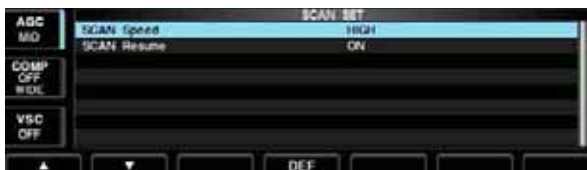

- ① Push [SCAN] [F-5] to select scan screen.
- ② Push [SET] [F-7] to select scan set mode.
- ③ Push [▲] [F-1] or [▼] [F-2] to select the desired item.
- ④ Rotate the main dial to select the desired condition.
 - Push and hold [DEF] [F-4] for 1 sec. to select the default setting.
- ⑤ Push [EXIT/SET] to return to scan menu.

Scan Speed	HIGH
Select the desired scan speed from high and low.	<ul style="list-style-type: none"> • HIGH : scan is faster • LOW : scan is slower

Scan Resume	ON
Set the scan resume function ON and OFF.	<ul style="list-style-type: none"> • ON : When detecting a signal, scan pauses for 10 sec., then resumes. When a signal disappears, scan resumes 2 sec. later. • OFF : When detecting a signal, cancels scanning.

■ Programmed scan operation

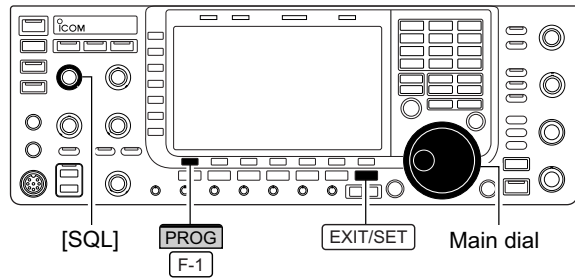

- ① Push [EXIT/SET] several times to close a multi-function screen, if necessary.
- ② Select VFO mode.
- ③ Select the desired operating mode.
 - The operating mode can also be changed while scanning.
- ④ Push [SCAN] [F-5] to select the scan screen.
- ⑤ Set [SQL] open or closed.
 - See page 9-2 for squelch condition.
- ⑥ Push [PROG] [F-1] to start the programmed scan.
 - “PROGRAM SCAN” and decimal points blink while scanning.
- ⑦ When the scan detects a signal, scan stops, pauses or ignores it depending on the resume setting and the squelch condition.
- ⑧ To cancel the scan, push [PROG] [F-1].
 - Rotating the main dial also cancels the scan.
- ⑨ Push and hold [RECALL] [F-6] for 1 sec. to recall the frequency that is set before starting the scan, if desired.

/// If the same frequencies are programmed into the scan edge memory channel P1 and P2, programmed scan will not start.

■ ΔF scan operation

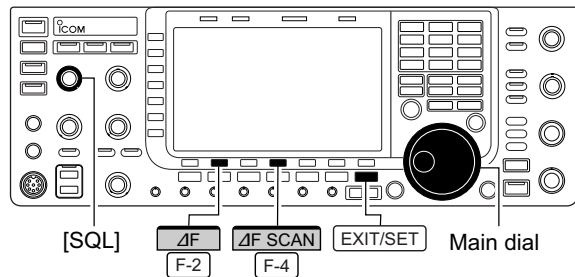

- ① Push [EXIT/SET] several times to close a multi-function screen, if necessary.
- ② Select VFO mode or a memory channel.
- ③ Select the desired operating mode.
 - The operating mode can also be changed while scanning.
- ④ Push [SCAN] [F-5] to select the scan screen.
- ⑤ Set the main band's [SQL] open or closed.
 - See page 9-2 for squelch condition.
- ⑥ Set the ΔF span by pushing [ΔF SPAN] [F-4].
 - ±5 kHz, ±10 kHz, ±20 kHz, ±50 kHz, ±100 kHz, ±500 kHz and ±1000 kHz are selectable.
- ⑦ Set center frequency of the ΔF span.
- ⑧ Push [ΔF] [F-2] to start the ΔF scan.
 - “ΔF SCAN” and decimal points blink while scanning.
- ⑨ When the scan detects a signal, the scan stops, pauses or ignores it depending on the resume setting and the squelch condition.
- ⑩ To cancel the scan, push [ΔF] [F-2].
 - Rotating the main dial also cancels the scan.
- ⑪ Push and hold [RECALL] [F-6] for 1 sec. to recall the frequency that was set before starting the scan.

■ Fine programmed scan/Fine ΔF scan

In fine scan (programmed or ΔF), the scan speed decreases when the squelch opens, but the transceiver keeps scanning. The scanning tuning step shifts from 50 Hz to 10 Hz when the squelch opens.

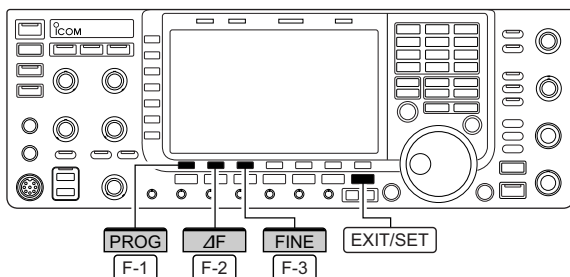

- ① Push [EXIT/SET] several times to close a multi-function screen, if necessary.
- ② Push [SCAN] [F-5] to select the scan screen.
- ③ Set for programmed scan or ΔF scan as described on previous page.
- ④ Push [PROG] [F-1] or [ΔF] [F-2] to start a scan.
 - “PROGRAM SCAN” or “ ΔF SCAN” and decimal points blink while scanning.
- ⑤ Push [FINE] [F-3] to start a fine scan.
 - “FINE PROGRAM SCAN” or “FINE ΔF SCAN” blinks instead of “PROGRAM SCAN” or “ ΔF SCAN,” respectively.
- ⑥ When the scan detects a signal, the scan speed decreases but scan does not stop.
- ⑦ Push [PROG] [F-1] or [ΔF] [F-2] to stop the scan; push [FINE] [F-3] to cancel the fine scan.
 - Rotating the main dial also cancels the scan.
- ⑧ Push and hold [RECALL] [F-6] for 1 sec. to recall the frequency that is set before starting the scan, if desired.

Memory scan operation

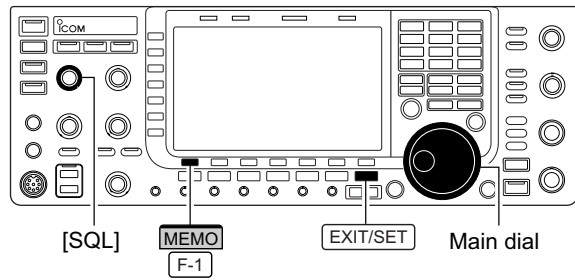

- ① Push [EXIT/SET] several times to close a multi-function screen, if necessary.
- ② Select memory mode.
- ③ Push [SCAN] [F-5] to select the scan screen.
- ④ Set [SQL] open or closed.
 - See page 9-2 for squelch condition.
- ⑤ Push [MEMO] [F-1] to start the memory scan.
 - “MEMORY SCAN” and decimal points blink while scanning.
- ⑥ When the scan detects a signal, the scan stops, pauses or ignores it depending on the resume setting and the squelch condition.
- ⑦ To cancel the scan, push [MEMO] [F-1].
 - Rotating the main dial also cancels the scan.

2 or more memory channels must be programmed for memory scan to start.

Select memory scan operation

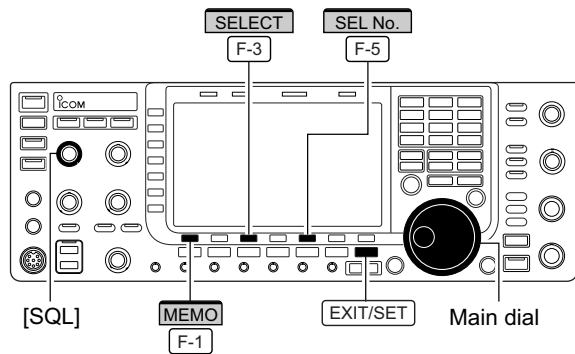

- ① Push [EXIT/SET] several times to close a multi-function screen, if necessary.
- ② Select memory mode.
- ③ Push [SCAN] [F-5] to select the scan screen.
- ④ Set [SQL] open or closed.
 - See page 9-2 for squelch condition.
- ⑤ Push [SEL No.] [F-5] several times to select the select scan number from ★1, ★2, ★3 and ★1/★2/★3.
- ⑥ Push [MEMO] [F-1] to start the memory scan.
 - “MEMORY SCAN” and decimal points blink while scanning.
- ⑦ Push [SELECT] [F-3] to start select memory scan; push [SELECT] [F-3] again to return to memory scan, if desired.
 - “SELECT MEMORY SCAN” blinks instead of “MEMORY SCAN” during select memory scan.
- ⑧ When the scan detects a signal, the scan stops, pauses or ignores it depending on the resume setting and the squelch condition.
- ⑨ To cancel the scan, push [MEMO] [F-1].
 - Rotating the main dial also cancels the scan.

2 or more memory channels must be designated as select memory channels, as well as the same select scan channel number, for select memory scan to start.

■ Setting select memory channels

◇ Setting in scan screen



- ① Push **[EXIT/SET]** several times to close a multi-function screen, if necessary.
- ② Select memory mode.
- ③ Push **[SCAN] [F-5]** to select the scan screen.
- ④ Select the desired memory channel to set as a select memory channel.
 - **[▲] / [▼]** keys and direct keypad selections can be used.
- ⑤ Push **[SELECT] [F-3]** several times to set the memory channel as a select memory ★1, ★2, ★3 or not.
- ⑥ Repeat steps ④ to ⑤ to program another memory channel as a select memory channel.
- ⑦ Push **[EXIT/SET]** to exit the scan screen.

◇ Setting in memory list screen



- ① Push **[EXIT/SET]** several times to close a multi-function screen, if necessary.
- ② Push **[MEMORY] [F-4]** to select memory list screen.
- ③ Rotate the main dial while pushing **[ROLL] [F-1]** or **[SET] [F-2]** to select the desired memory channel.
 - **[▲] / [▼]** keys and direct keypad selections can be used.
- ④ Push **[SELECT] [F-3]** several times to set the memory channel as a select memory ★1, ★2, ★3 or not.
- ⑤ Repeat steps ③ to ④ to program another memory channel as a select memory channel.
- ⑥ Push **[EXIT/SET]** to exit the memory list screen.

◇ Erasing the select scan setting



- ① Push **[EXIT/SET]** several times to close a multi-function screen, if necessary.
- ② Push **[MEMORY] [F-4]** to select memory list screen, or push **[SCAN] [F-5]** to select scan screen.
- ③ Push and hold **[SELECT] [F-3]** for 1 sec. to display memory select all clear window.
- ④ Push one of the following keys to clear all select scan setting.
 - [F-1★1]** : Clears all ★1 setting.
 - [F-2★2]** : Clears all ★2 setting.
 - [F-3★3]** : Clears all ★3 setting.
 - [F-4★1,2,3]** : Clears all select setting.
- ⑤ Push **[EXIT/SET]** to exit the memory list screen.

■ Tone scan

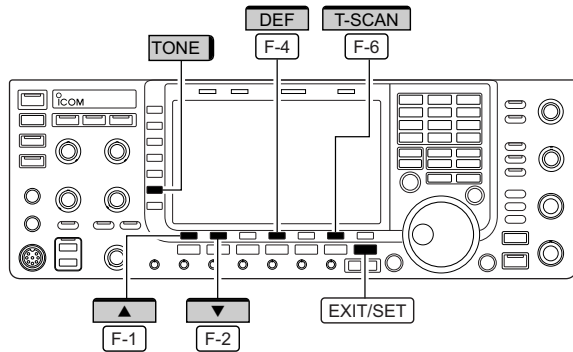

The transceiver can detect subaudible tones in a received signal. By monitoring a signal that is being transmitted on a repeater input frequency, you can determine the tone frequency required to access the repeater.

- ① Set the desired frequency or memory channel to be checked for a tone frequency.
- ② Push **[AM/FM]** several times to select FM mode.
- ③ Push and hold **[TONE]** (MF6) for 1 sec. to enter tone frequency screen.
- ④ Push **[▲]** **[F-1]** or **[▼]** **[F-2]** to check the repeater tone frequency or tone squelch frequency, respectively.
- ⑤ Push **[T-SCAN]** **[F-6]** to start the tone scan.
 - "SCAN" blinks while scanning.
- ⑥ When the tone frequency is detected, the tone scan pauses.
 - The tone frequency is set temporarily on a memory channel. Program the memory channel to store the tone frequency permanently.
 - The decoded tone frequency is used for the repeater tone frequency or tone squelch frequency.
- ⑦ To stop the scan, push **[T-SCAN]** **[F-6]**.
 - Push and hold **[DEF]** **[F-4]** for 1 sec. to select the default frequency.
- ⑧ Push **[EXIT/SET]** to exit tone frequency screen.

- Antenna connection and selection 10-2
- Antenna memory settings 10-3
 - ◇ Antenna type selection 10-3
 - ◇ Temporary memory 10-4
 - ◇ Antenna selection mode 10-4
 - ◇ Receive antenna I/O setting 10-5
- Antenna tuner operation 10-6
 - ◇ Tuner operation 10-6
 - ◇ If the tuner cannot tune the antenna 10-7

■ Antenna connection and selection

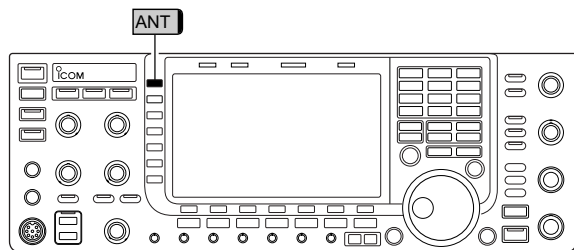

The IC-7700 has 4 antenna connectors for the HF/50 MHz bands, [ANT1], [ANT2], [ANT3], and [ANT4].

For each operating band the IC-7700 covers, there is a band memory which can memorize the selected antenna. When you change the operating frequency outside of a band, the previously used antenna is automatically selected (see below) for the new band. This function allows automatic switching of 4 separate antennas for HF and 50 MHz bands operation.

• Antenna selection mode: “Auto”

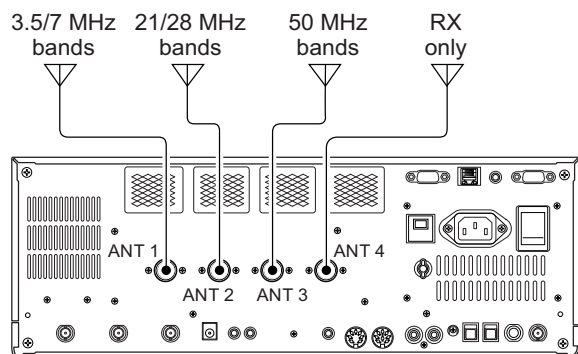

After an antenna has been selected for use (by pushing [ANT] (MF1)), the antenna is automatically selected whenever that band is used.

[EXAMPLE]: a 3.5/7 MHz antenna is connected to [ANT1], a 21/28 MHz antenna is connected to [ANT2], a 50 MHz antenna is connected to [ANT3]. When the antenna selector function is set to “Auto,” an antenna is automatically selected when changing bands. A receive-only antenna can be specified for [ANT4].

• Antenna selection mode: “Manual”

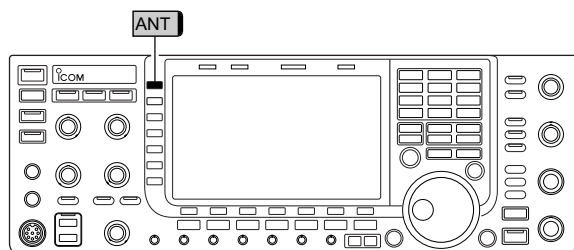

When “Manual” is selected, you can use the all antenna connectors, [ANT1] [ANT2], [ANT3] and [ANT4], however, band memory does not function. In this case you must select an antenna manually.

• Antenna selection mode: “OFF”

In this case, only [ANT1] antenna connector can be used. [ANT] (MF1) switch does not function.

■ Antenna memory settings

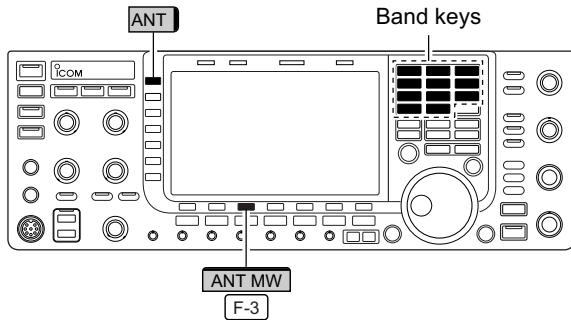

This function stores the antenna connector number for each frequency band.

- ① Push [EXIT/SET] several times to close multi-function screen, if necessary.
- ② Push and hold [ANT] (MF1) for 1 sec. to select antenna set screen.
- ③ Select the desired frequency band with a band key.
- ④ Push [ANT] (MF1) several times to select the desired antenna number that you want to set for the selected frequency band.
 - “★” appears.
- ⑤ Push and hold [ANT MW] [F-3] for 1 sec. to store the antenna selection into the antenna memory.
 - “★” disappears.
- ⑥ Repeat the steps ③ to ⑤ to store the antenna selection for another frequency bands, if desired.
- ⑦ Push [EXIT/SET] to exit antenna set screen.

◇ Antenna type selection

When no antenna is connected to [ANT2], [ANT3], and/or [ANT4], these antenna connectors can be deactivated — deleting the antenna number from the available selections. This prevents the transceiver from accidentally transmitting into an unused antenna connector. In addition, a receive-only antenna can be specified for [ANT4].

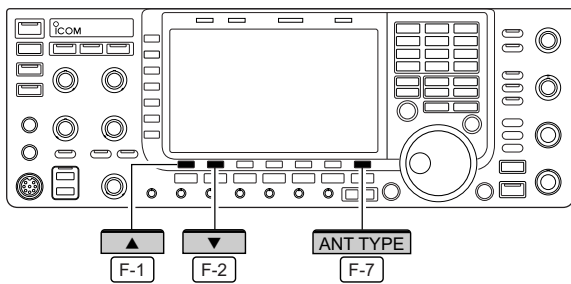

- ① Select the antenna set screen as described above.
- ② Push [ANT TYPE] [F-7] to select antenna type set screen.
- ③ Push [▲] [F-1] or [▼] [F-2] to select the desired antenna.
- ④ Rotate the main dial to select the desired antenna condition from TX/RX, RX (ANT4 only) and OFF.
 - TX/RX : Select when an antenna is connected.
 - OFF : Select when no antenna is connected.
 - RX : Select when a receive only antenna is connected. (available for the [ANT4] only)
- ⑤ Push [EXIT/SET] to exit antenna type set screen.

✓ For your information

The “OFF” antennas cannot be selected with [ANT] (MF1) switch operation, or with the antenna memory setting.

When “RX” is selected for [ANT4], “1/R,” “2/R” and “3/R” selections will be added for the selection for both [ANT] (MF1) switch operation and the antenna memory setting. In these selections, the antenna connected to [ANT1], [ANT2] and/or [ANT3] will be used for transmission and the antenna connected to [ANT4] will be used for reception.

■ Antenna memory settings (continued)

◇ Temporary memory

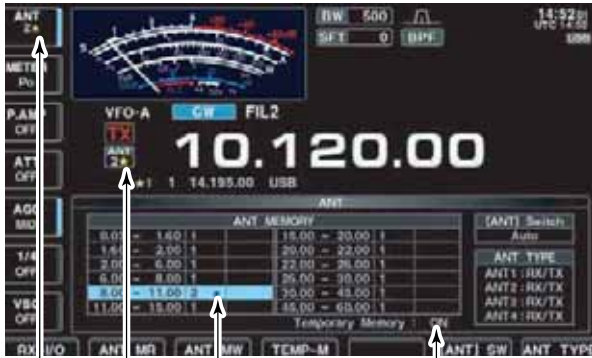

“★” indicators appear when a different antenna from the original is selected.

Push [F-4•TEMP-M] to turn the temporary memory ON and OFF.

The antenna temporary memory memorizes the manually selected antenna. The selected antenna will be re-called even if frequency band has been changed.

- ① Select the antenna set screen.
- ② Push [TEMP-M] [F-4] to turn the temporary memory ON and OFF.
- ③ Select the desired frequency band with a band key.
- ④ Push [ANT] (MF1) to select the desired antenna.
 - “★” appears when a different antenna from the original is selected.
- ⑤ Push [ANT MR] [F-2] to re-call the original antenna.
 - “★” disappears.
- ⑥ Push [EXIT/SET] to exit antenna set screen.

CAUTION! Before transmitting with the manually selected antenna, make sure the selected antenna suits the operating frequency. Otherwise the transmitter may be damaged.

◇ Antenna selection mode



Push [ANT SW] [F-6] to select the antenna selection mode.

The automatic antenna selection (antenna memory) and the [ANT] (MF1) switch function can be deactivated if desired.

- ① Select the antenna set screen.
- ② Push [ANT SW] [F-6] to select the antenna selection from Auto, OFF and Manual.
 - Auto : Use the antenna memory. Antenna selection with [ANT] switch is also available.
 - OFF : Only the antenna connected to [ANT1] can be used. [ANT] switch is deactivated.
 - Manual: Deactivate the antenna memory function. Antenna can be selected with [ANT] switch operation only.
- ③ Push [EXIT/SET] to exit antenna set screen.

◆ Receive antenna I/O setting

In default setting, receive antenna connectors, [RX ANT-IN] and [RX ANT-OUT], on the rear panel are deactivated and are connected internally by the switching relay. If you want to connect an external preamp or low-pass filter between the [RX ANT-IN] and [RX ANT-OUT], you must activate them as described below.

- ① Select the antenna set screen.
- ② Select the desired frequency band with a band key.
- ③ Push [RX-I/O] [F-1] to activate the receive antenna connectors ([RX ANT-IN] and [RX ANT-OUT]).
 - “RX-I/O” indicators appear when [RX ANT-IN] and [RX ANT-OUT] are active.
- ④ Repeat steps ② and ③, if desired.
- ⑤ Push [EXIT/SET] to exit antenna set screen.

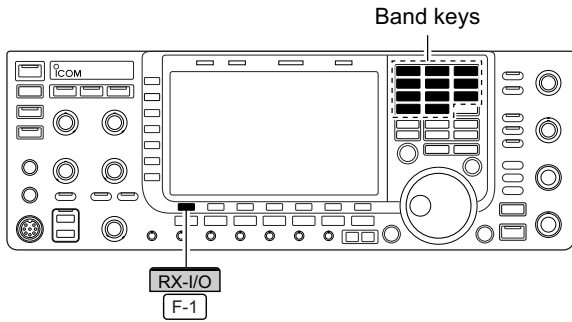

“RX-I/O” indicators appear when [RX ANT-IN] and [RX ANT-OUT] are active.

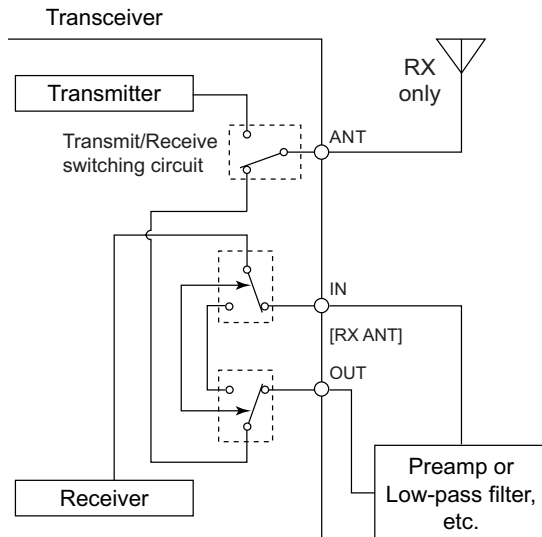

■ Antenna tuner operation

The internal automatic antenna tuner matches the transceiver to the connected antenna automatically. After the tuner matches an antenna, the variable capacitor settings are memorized as a preset point for each frequency range (100 kHz steps). Therefore, when you change the frequency range, the variable capacitors are automatically preset to the memorized setting.

CAUTION: NEVER transmit with the tuner ON when no antenna is connected. This will damage the transceiver. Be careful of the antenna selection.

◇ Tuner operation

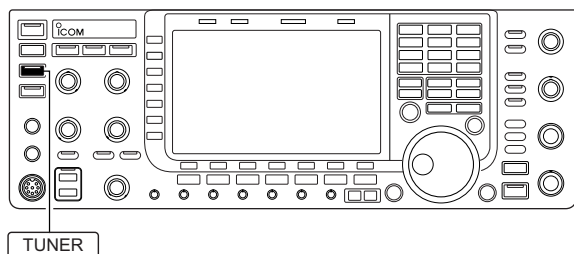

- ➔ Push **TUNER** to turn the internal antenna tuner ON. The antenna is tuned automatically when the antenna SWR is higher than 1.5:1.
 - When the tuner is ON, [TUNER] switch indicator lights green.
 - While tuning, [TUNER] switch indicator blinks green.

NOTES:

- NEVER transmit without an antenna properly connected to antenna port in use.
- When 2 or more antennas are connected, select the antenna to be used with [ANT].
- If the SWR is higher than about 1.5:1 when tuning above 100 kHz on an antenna's preset point, push and hold **TUNER** for 1 sec. to start manual tuning.
- The internal tuner may not be able to tune in AM mode. In such cases, push and hold **TUNER** for 1 sec. to manually tune.

• MANUAL TUNING

During SSB operation at low voice levels, the internal tuner may not be tuned correctly. In such cases, manual tuning is helpful.

- ➔ Push and hold **TUNER** for 1 sec., to start manual tuning.
 - A side tone is emitted and [TUNER] switch indicator blinks red while tuning.
 - If the tuner cannot reduce the SWR to less than 1.5:1 after 20 sec. of tuning, the [TUNER] switch indicator goes out.

• AUTOMATIC TUNER START (HF bands only)

If you want to deactivate the tuner under conditions of VSWR 1.5:1 or less, use the auto tuner start function and turn the tuner OFF. This function activates the tuner automatically when the SWR exceeds 1.5:1.

This function is turned ON in set mode. (p. 12-13).

■ Antenna tuner operation (continued)

• PTT TUNER START

The tuner is always tuned when the PTT is pushed after the frequency is changed (more than 1% from last-tuned frequency). This function removes the “push and hold [TUNER]” operation and activates for the first transmission on a new frequency.

This function is turned ON in set mode. (p. 12-13).

• Antenna tuner of the IC-PW1

When using an external antenna tuner such as the IC-PW1's tuner, tune with the external antenna tuner, and turn OFF the IC-7700's tuner. After tuning is completed, turn the internal tuner ON. Otherwise, both tuners tune simultaneously and correct tuning may not be obtained.

See the instruction manual included with each antenna tuner for their respective operations.

◇ If the tuner cannot tune the antenna

Check the following and try again:

- the [ANT] connector selection.
- the antenna connection and feedline.
- the untuned antenna SWR. (Less than 3:1 for HF bands; Less than 2.5:1 for 50 MHz band)
- the transmit power. (8 W for HF bands; 15 W for 50 MHz band)
- the power source voltage/capacity.

If the tuner cannot reduce the SWR to less than 1.5:1 after checking the above, perform the following:

- repeat manual tuning several times.
- tune with a 50 Ω dummy load and re-tune the antenna.
- turn power OFF and ON.
- adjust the antenna feedline length.
(This is effective for higher frequencies in some cases.)
- Some antennas, especially for low bands, have a narrow bandwidth. These antennas may not be tuned at the edge of their bandwidth, therefore, tune such an antenna as follows:

[Example]: Suppose you have an antenna which has an SWR of 1.5:1 at 3.55 MHz and an SWR of 3:1 at 3.8 MHz.

- ① Push [TUNER] to turn the antenna tuner ON.
- ② Select CW mode.
- ③ Turn OFF the break-in function. (p. 6-3)
- ④ Push [TRANSMIT] to set to the transmit condition.
- ⑤ Set 3.55 MHz and key down.
- ⑥ Set 3.80 MHz and key down.
- ⑦ Push [TRANSMIT] to return to the receive condition.

■ Time set mode	11-2
■ Daily timer setting	11-3
■ Setting sleep timer	11-4
■ Timer operation	11-4

Time set mode

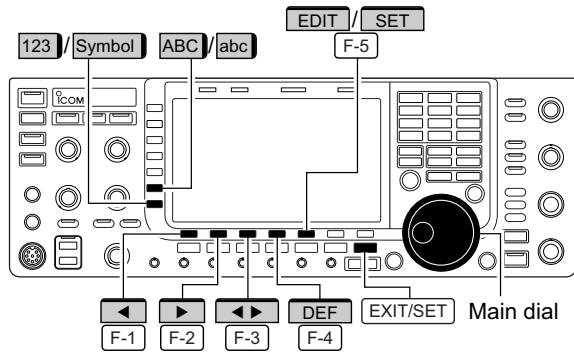

The IC-7700 has a built-in calendar and 24-hour clock (accuracy ± 75 sec. per month) with daily power ON/OFF timer functions. Before operating these timer functions, set the current date and time.

- ① Push [EXIT/SET] to close multi-function screen, if necessary.
- ② Push [SET] [F-7] to select set mode menu screen.
- ③ Push [TIME] [F-4] to select time set mode.
- ④ Push [\blacktriangle] [F-1] or [\blacktriangledown] [F-2] to select the desired item.
- ⑤ Rotate the main dial to set or select the desired value or condition.
- ⑥ Push [EXIT/SET] to exit time set mode.

Date	2000 - 1 - 1 (Sat)
Sets the date.	<ol style="list-style-type: none"> ① Push [\blacktriangleleft] [F-3] to select between the year and the month/day, then rotate the main dial to select them. <ul style="list-style-type: none"> • The date setting and "DATE-set Push [SET]" indication blink. ② Push [SET] [F-5] to set the date.

Time (Now)	1:23
Sets the local time.	<ol style="list-style-type: none"> ① Rotate the main dial to set the local time. <ul style="list-style-type: none"> • The time setting and "TIME-set Push [SET]" indication blink. ② Push [SET] [F-5] to set the time.

CLOCK2 Function	ON
Turns the CLOCK2 indicator ON and OFF. CLOCK2 is convenient to indicate UTC or other country's local time, etc.	<ul style="list-style-type: none"> • ON : The CLOCK2 indicator is displayed below the local time indication. • OFF : The CLOCK2 indicator does not display.

CLOCK2 Offset	$\pm 0:00$
Sets the desired off-set time period for CLOCK2 display within $-24:00$ to $+24:00$ in 5 min. steps.	<ul style="list-style-type: none"> • Push and hold [DEF] [F-4] for 1 sec. to select the default value.

CLOCK2 Name	UTC
Sets the desired 3-character name for CLOCK2.	<ol style="list-style-type: none"> ① Push [EDIT] [F-5] to select the name edit condition. <ul style="list-style-type: none"> • The cursor under the 1st character blinks. ② Push [ABC], [abc], [123] or [Symbol] to select the character group, then rotate the main dial to select the character. <ul style="list-style-type: none"> • Push [ABC] or [abc] to toggle capital and small letters. • Push [123] or [Symbol] to toggle numerals and symbols. • Push [\blacktriangleleft] [F-1] or [\blacktriangleright] [F-2] for cursor movement. • Push [DEL] [F-3] to delete the selected character. • Push [SPACE] [F-4] to input a space. • Pushing the transceiver's keypad, [0]–[9], can also enter numerals. ③ Push [EXIT/SET] to set the name.
Capital letters, small letters, numerals, some symbols (! # \$ % & ¥ ? " ' ` ^ + - * / . , ; = < > () [] { } _ ~ @) and spaces can be used.	

■ Daily timer setting

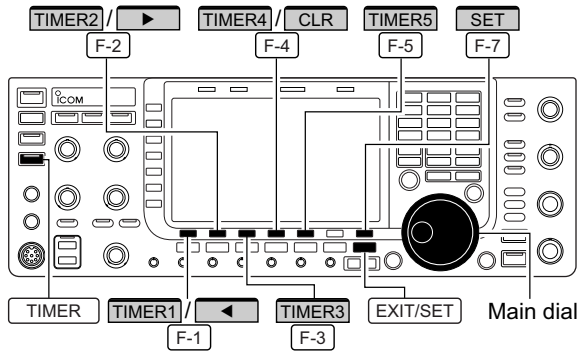

The transceiver turns power ON and/or OFF automatically on the specified day and time, with the specified frequency settings.

- ① Push [EXIT/SET] several times to close multi-function screen, if necessary.
- ② Push and hold [TIMER] for 1 sec. to select timer set screen.
- ③ Push one of [TIMER1] [F-1] to [TIMER5] [F-5] to select the desired timer.
- ④ Rotate the main dial to select the timer action ON and OFF.
- ⑤ Push [▶] [F-2] to select the “DAY” cell, then rotate the main dial to select the desired day of the week.
 - Select “---” not to specify the day of the week. The timer will function every day in this case.
 - Once a day of the week is selected, push [CLR] [F-4] to select “---”.
- ⑥ Push [▶] [F-2] to select the “REPEAT” cell, then rotate the main dial to select the repeat function ON and OFF.
 - ON : The timer functions every selected day of the week. (repeats)
 - OFF : The timer does not repeat.
- ⑦ Push [▶] [F-2] to select the “ON” cell, then rotate the main dial to set the desired transceiver power ON time.
 - When using power OFF timer only, push [CLR] [F-4] to select “---.” This setting cannot be set when the power OFF timer is set to “---.”
- ⑧ Push [▶] [F-2] to select the “OFF” cell, then rotate the main dial to set the desired transceiver power OFF time.
 - When using power ON timer only, push [CLR] [F-4] to select “---.” This setting cannot be set when the power ON timer is set to “---.”
- ⑨ Push [▶] [F-2] to select the “Mch” cell, then rotate the main dial to select the desired memory channel number.
 - If using the currently set VFO condition, push [CLR] [F-4] to select “---.”
- ⑩ Push [SET] [F-7] to set the timer.
 - The timer indicator above [TIMER] switch lights green.
- ⑪ Repeat steps ③ to ⑩ to set other timers, if desired.
- ⑫ Push [EXIT/SET] to exit timer set screen.

Setting sleep timer

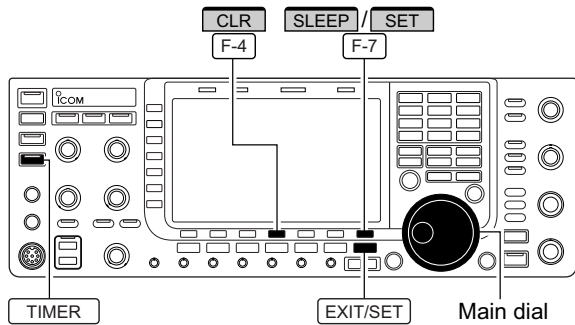

The sleep timer turns the transceiver power OFF automatically after passing the set period. The timer can be set to 5–120 min. in 5 min. steps.

The sleep timer function counts the 'minute' units, and does not count the 'second' units. For example, when the sleep timer is started at 12:00 59, first one minute past for just 1 sec. That is way it has a max. 59 sec. error. This is normal, not a malfunction.

- ① Push [EXIT/SET] several times to close a multi-function screen, if necessary.
- ② Push and hold [TIMER] for 1 sec. to select timer set screen.
- ③ Push [SLEEP] [F-7] to select the sleep timer set condition.
 - "—" blinks.
- ④ Set the desired time period using the main dial.
 - "TIMER-set Push [SET]" blinks.
 - Push [CLR] [F-4] to select "—" to cancel the setting.
- ⑤ Push [SET] [F-7] to set the time.
 - Push [EXIT/SET] to cancel the setting.
 - The timer indicator above [TIMER] switch lights green.
- ⑥ Push [EXIT/SET] to exit timer set screen.
- ⑦ The transceiver emits 10 beeps and turns OFF after the sleep timer period elapses.
 - The timer indicator blinks while beeping.
 - Push [TIMER] momentarily to cancel the sleep timer, if desired.

Timer operation

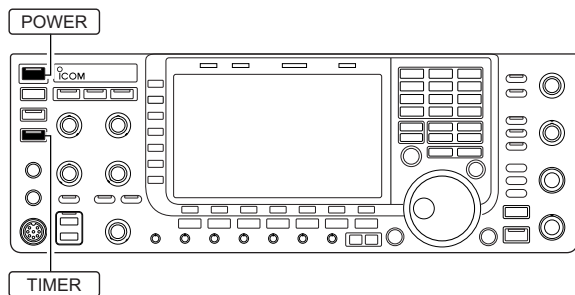

- ① Preset the daily timer as described previously.
- ② Push [TIMER] momentarily to turn the timer function ON.
 - The timer indicator above this switch lights green when the timer function is ON.
- ③ Push and hold [POWER] for 1 sec. to turn the power OFF.
 - The timer indicator lights continuously.
- ④ When the set time arrives, the power is automatically turned ON.
- ⑤ The transceiver emits 10 beeps and turns OFF after the power-off period elapses.
 - The timer indicator blinks while beeping.
 - Push [TIMER] momentarily to cancel the sleep timer, if desired.

Timer action in the timer set screen must be selected ON to enable timer operation, described in page 11-3 steps ④.

■ Set mode description	12-2
◇ Set mode operation	12-2
◇ Screen arrangement	12-3
■ Level set mode	12-4
■ ACC set mode	12-7
■ Display set mode	12-9
■ Others set mode	12-12
■ USB-Memory set menu	12-19
◇ USB-Memory set screen arrangement	12-19
◇ Save option set mode	12-20
◇ Load option set mode	12-21
■ File saving	12-22
■ File loading	12-23
■ Changing a file name	12-24
■ Deleting a file	12-25
■ Unmounting USB-Memory	12-25
■ Formatting the USB-Memory	12-26

■ Set mode description

Set mode is used for programming infrequently changed values or conditions of functions. The IC-7700 has a level set mode, display set mode, time set mode, accessory set mode, Others set mode and USB-Memory set menu.

◇ Set mode operation



- ① Push [EXIT/SET] several times to close a multi-function screen, if necessary.
- ② Push [SET] [F-7] to select set mode menu screen.
 - Pushing and holding [EXIT/SET] for 1 sec. also selects set mode menu screen.
- ③ Push [LEVEL] [F-1], [ACC] [F-2], [DISP] [F-3], [TIME] [F-4], [OTHERS] [F-5] or [USB] [F-7] to enter the desired set mode.
- ④ For level, accessory, display and Others set mode, push [WIDE] [F-7] to toggle wide and normal screen.
- ⑤ Push [▲] [F-1] or [▼] [F-2] to select the desired item, then rotate the main dial to adjust/select the desired value or condition.
 - Pushing [◀ ▶] [F-3] operation may be necessary for some items.
- ⑥ Push [EXIT/SET] twice to exit set mode.

◇ Screen arrangement



• Display set mode (p. 12-9)



• Set mode menu screen (p. 12-2)



• Time set mode (p. 11-2)



• Level set mode (p. 12-4)



• Others set mode (p. 12-12)



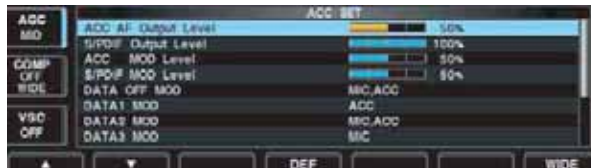

• ACC set mode (p. 12-7)



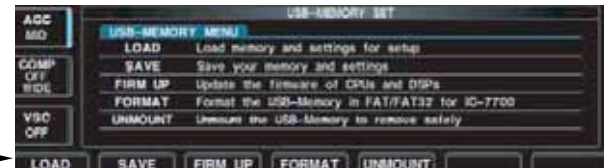

• USB-Memory set menu (p. 12-19)





■ Level set mode

SSB RX HPF/LPF	
Sets the low-pass filter (100 Hz to 2000 Hz) and high-pass filter (500 Hz to 2400) of the receive audio in 100 Hz steps in SSB mode. (default: OFF)	
 NOTE: When this setting is active, below 2 items will be reset to default value, '0.'	



Tone (Bass)	 0
Sets the bass level of the receive audio tone in SSB mode from -5 to +5. (default: 0)	

Tone (Treble)	 0
Sets the treble level of the receive audio tone in SSB mode from -5 to +5. (default: 0)	

AM RX HPF/LPF	
Sets the low-pass filter (100 Hz to 2000 Hz) and high-pass filter (500 Hz to 2400) of the receive audio in 100 Hz steps in AM mode. (default: OFF)	
 NOTE: When this setting is active, below 2 items will be reset to default value, '0.'	

Tone (Bass)	 0
Sets the bass level of the receive audio tone in AM mode from -5 to +5. (default: 0)	

Tone (Treble)	 0
Sets the treble level of the receive audio tone in AM mode from -5 to +5. (default: 0)	

FM RX HPF/LPF	
Sets the low-pass filter (100 Hz to 2000 Hz) and high-pass filter (500 Hz to 2400) of the receive audio in 100 Hz steps in FM mode. (default: OFF)	
 NOTE: When this setting is active, below 2 items will be reset to default value, '0.'	

Tone (Bass)	 0
Sets the bass level of the receive audio tone in FM mode from -5 to +5. (default: 0)	

Tone (Treble)	 0
Sets the treble level of the receive audio tone in FM mode from -5 to +5. (default: 0)	

■ Level set mode (continued)

CW RX HPF/LPF 

Sets the low-pass filter (100 Hz to 2000 Hz) and high-pass filter (500 Hz to 2400) of the receive audio in 100 Hz steps in CW mode. (default: OFF)

RTTY RX HPF/LPF 

Sets the low-pass filter (100 Hz to 2000 Hz) and high-pass filter (500 Hz to 2400) of the receive audio in 100 Hz steps in RTTY mode. (default: OFF)

PSK RX HPF/LPF 

Sets the low-pass filter (100 Hz to 2000 Hz) and high-pass filter (500 Hz to 2400) of the receive audio in 100 Hz steps in PSK mode. (default: OFF)

SSB TX Tone (Bass)  0

Sets the bass level of the transmit audio tone in SSB mode from -5 to +5. (default: 0)

Tone (Treble)  0

Sets the treble level of the transmit audio tone in SSB mode from -5 to +5. (default: 0)

AM TX Tone (Bass)  0

Sets the bass level of the transmit audio tone in AM mode from -5 to +5. (default: 0)

Tone (Treble)  0

Sets the treble level of the transmit audio tone in AM mode from -5 to +5. (default: 0)

FM TX Tone (Bass)  0

Sets the bass level of the transmit audio tone in FM mode from -5 to +5. (default: 0)

Tone (Treble)  0

Sets the treble level of the transmit audio tone in FM mode from -5 to +5. (default: 0)

■ Level set mode (continued)

SSB TBW (WIDE)	100 – 2900
Sets the transmission passband width to wide setting by changing the lower and higher cut-off frequencies.	Lower freq. : 100 (default), 200, 300 and 500 Hz Higher freq.: 2500, 2700, 2800 and 2900 Hz (default)

SSB TBW (MID)	300 – 2700
Sets the transmission passband width to middle setting by changing the lower and higher cut-off frequencies.	Lower freq. : 100, 200, 300 (default) and 500 Hz Higher freq.: 2500, 2700 (default), 2800 and 2900 Hz

SSB TBW (NAR)	500 – 2500
Sets the transmission passband width to narrow setting by changing the lower and higher cut-off frequencies.	Lower freq. : 100, 200, 300 and 500 Hz (default) Higher freq.: 2500 (default), 2700, 2800 and 2900 Hz

Speech Level	 50%
Sets the voice synthesizer audio output level from 0 to 100% in 1% steps. (default: 50%)	

Side Tone Level	 50%
Sets the side tone output level from 0 to 100% in 1% steps. (default: 50%)	

Side Tone Level Limit	ON
Turns the side tone output level limiting capability from ON and OFF. (default: ON)	

Beep Level	 50%
Sets the key-touch beep output level from 0 to 100% in 1% steps. (default: 50%)	

Beep Level Limit	ON
Turns the key-touch beep output level limiting capability from ON and OFF. (default: ON)	

Phones Level Ratio	 1.00
Sets the ratio for audio output level from the headphone toward to the internal speaker within a range of 0.60 to 1.40 in 0.01 steps. (default: 1.00)	

■ ACC set mode

ACC AF Output Level	 50%
Sets the desired audio output level, output from [ACC1], within 0 to 100% in 1% steps.	
• Outputs approx. 200 mV at 50% (default) setting.	

S/PDIF Output Level	 100%
Sets the desired output level of [S/P DIF], within 0 to 100% in 1% steps. (default: 100%)	

ACC MOD Level	 50%
Sets the desired audio input level for modulation from [ACC1].	
• Approx. 100 mV at 50% (default) setting.	

S/PDIF MOD Level	 50%
Sets the desired input level for modulation from [S/P DIF], within 0 to 100% in 1% steps. (default: 50%)	

DATA OFF MOD	MIC,ACC
Selects the desired connector(s) for modulation input when data mode is not in use.	<ul style="list-style-type: none"> • MIC : Use the signals from [MIC]. • ACC : Use the signals from [ACC1] (pin 4). • MIC,ACC : Use the signals from [MIC] and [ACC1] (pin 4). (default) • S/P DIF : Use the signals from [S/P DIF].

DATA1 MOD	ACC
Selects the desired connector(s) for modulation input when data 1 mode (D1) is in use.	<ul style="list-style-type: none"> • MIC : Use the signals from [MIC]. • ACC : Use the signals from [ACC1] (pin 4). (default) • MIC,ACC : Use the signals from [MIC] and [ACC1] (pin 4). • S/P DIF : Use the signals from [S/P DIF].

DATA2 MOD	MIC,ACC
Selects the desired connector(s) for modulation input when data 2 mode (D2) is in use.	<ul style="list-style-type: none"> • MIC : Use the signals from [MIC]. • ACC : Use the signals from [ACC1] (pin 4). • MIC,ACC : Use the signals from [MIC] and [ACC1] (pin 4). (default) • S/P DIF : Use the signals from [S/P DIF].

■ ACC set mode (continued)

DATA3 MOD	MIC
<p>Selects the desired connector(s) for modulation input when data 3 mode (D3) is in use.</p>	<ul style="list-style-type: none"> • MIC : Use the signals from [MIC]. (default) • ACC : Use the signals from [ACC1] (pin 4). • MIC,ACC : Use the signals from [MIC] and [ACC1] (pin 4). • S/P DIF : Use the signals from [S/P DIF].

SEND Relay Type	Lead
<p>Selects the switching relay type for [RELAY] from Lead and MOSFET. Select the suitable relay type when connecting a non-com linear amplifier.</p>	<ul style="list-style-type: none"> • Lead : Use mechanical relay. (16 V DC/0.5 A max.; default) • MOS-FET : Use semiconductor type relay. (250 V/200 mA max.)

External Meter Output	Auto
<p>Selects the desired item for an external meter indication.</p>	<ul style="list-style-type: none"> • Auto : Outputs the receiving signal strength level during receive, and outputs the selected level (selected with [METER]), during transmit. (default) • S : Outputs the receiving signal strength level during receive. • Po : Outputs the transmitting power level during transmit. • SWR : Outputs the VSWR level during transmit. • ALC : Outputs the ALC level during transmit. • COMP : Outputs the compression level during transmit. • V_D : Outputs the drain terminal voltage of the final amplifier MOSFETs. • I_D : Outputs the drain current of the final amplifier MOSFETs.

External Meter Level	
<p>Sets the output level for an external meter indication with in 0 to 100% range in 1% steps.</p>	<ul style="list-style-type: none"> • Approx. 2.5 V at 50% (default) setting for full-scale indication. (4.7 kΩ impedance)

■ ACC set mode (continued)

REF IN/OUT	OFF
<p>Selects the transceiver's reference signal condition from IN, OFF and OUT.</p>	<ul style="list-style-type: none"> • IN : Use an external reference signal for the IC-7700. Turn the transceiver power OFF then ON to make the setting effective. • OFF : Not input/output the reference signal. (default) • OUT : Outputs the IC-7700 reference signal to externally connected equipment(s) for their reference. <p>NOTE: If the applied reference signal is off-frequency, or no signal is applied with "IN" selection, the IC-7700 will not work properly. Select "OFF" or "OUT" then reboot the IC-7700 in such case.</p>

REF Adjust	 50%
<p>Adjusts the internal reference signal frequency within 0 to 100% range in 1% steps during frequency calibration.</p>	<p>NOTE: Default setting is different for each transceiver.</p>

■ Display set mode

LCD Unit Bright	 50%
<p>Adjusts the LCD unit brightness from 0 (dark) to 100% (bright) range in 1% steps. (default: 50%)</p>	

Backlight (Switches)	 80
<p>Adjusts the switch indicators brightness from 1 (dark) to 100 (bright) range in 1 steps. (default: 80)</p>	

Display Type	A
<p>Selects the desired display type from A (Black back) and B (Blue back). (default: A)</p>	<p>See p.13-4 for details.</p>

Display Font	Basic (1)
<p>Selects the desired font for frequency readout from Basic (1), Basic (2), Italic, Round and Slim. (default: Basic (1))</p>	<p>See p.13-4 for details.</p>

■ Display set mode (continued)

Meter Response	MID
Set meter needle response from SLOW, MID and FAST. (default: MID)	This setting is effective for the standard and edge-wise meter type selections only.
Meter Type (Normal Screen)	Standard
Selects the desired S/RF meter type during normal screen indication from Standard, Edgewise and Bar. (default: Standard)	
Meter Type (Wide Screen)	Bar
Selects the desired S/RF meter type during wide screen or mini scope indication from Edgewise and Bar. (default: Bar)	
Meter Peak Hold (Bar)	ON
Turns the meter peak hold function ON and OFF. (default: ON) This function is used for the bar meter only.	
Memory Name	ON
Sets the memory name indication, during memory mode operation, ON and OFF. (default: ON)	<ul style="list-style-type: none"> • ON : The programmed memory name is displayed above the frequency indication. • OFF : No memory name is displayed even a memory name is programmed.
APF-Width Popup (APF OFF→ON)	ON
Selects the pop-up display for the APF filter width from ON and OFF. (default: ON)	
MN-Q Popup (MN OFF→ON)	ON
Enables the pop-up indication capability when the notch filter width is changed from ON to OFF. (default: ON)	

■ Display set mode (continued)

<p>Screen Saver Function</p> <p>Turns the screen saver function ON (15, 30 or 60 minutes) and OFF. (default: 60 min.)</p>	<p>60min</p> <p>The screen saver will activate when no operation is performed for the selected time period to protect the LCD from the “burn-in” effect.</p>
<p>Screen Saver Type</p> <p>Selects the screen saver type from “Bound,” “Rotation” and “Twist.” (default: Bound)</p>	<p>Bound</p> <p>The screen saver indication can be displayed for your reference while pushing and holding [PREVIEW] [F-5].</p>
<p>External Display</p> <p>Select “ON” when the external display is connected. (default: OFF)</p>	<p>OFF</p> <ul style="list-style-type: none"> At least 800×600 pixel resolution is required for the display.
<p>External Display Sync Pulse</p> <p>Selects the suitable pulse level for the connected external display from H and L. (default: H)</p>	<p>H</p>
<p>Opening Message</p> <p>Turns the opening message screen indication capability ON and OFF. (default: ON)</p>	<p>ON</p>
<p>My Call</p> <p>Sets the introductory text, up to 10-character long, displayed in the opening screen. Usually, you set your call sign for the opening screen. Capital letters, small letters, numerals, some symbols (– / . @) and spaces can be used.</p> <ol style="list-style-type: none"> Push [EDIT] [F-5] to select the name edit condition. <ul style="list-style-type: none"> The cursor under the 1st character blinks. Push [ABC] (MF6), [abc] (MF6), [123] (MF7) or [Symbol] (MF7) to select the character group, then rotate the main dial to select the character. <ul style="list-style-type: none"> Push [ABC] (MF6) or [abc] (MF6) to toggle capital and small letters. Push [123] (MF7) or [Symbol] (MF7) to toggle numerals and symbols. Push [◀] [F-1] or [▶] [F-2] for cursor movement. Push [DEL] [F-3] to delete the selected character. Push [SPACE] [F-4] to input a space. Pushing the transceiver’s keypad, [0]–[9], can also enter numerals. Push [EXIT/SET] to set the name. 	

■ Others set mode

Calibration Marker	OFF
<p>This item is used for a simple frequency check of the transceiver. (default: OFF) See p. 13-5 for calibration procedure.</p> <p>/// NOTE: Turn the calibration marker OFF after checking the frequency of the transceiver.</p>	

Beep (Confirmation)	ON
<p>A beep sounds each time a switch is pushed to confirm it. This function can be turned OFF for silent operation. (default: ON)</p> <p>The beep output level can be set in level set mode. (p. 12-6)</p>	

Beep (Band Edge)	ON
<p>A beep sounds when an operating frequency enters or exits an amateur band. This functions independent of the confirmation beep setting (above). (default: ON)</p> <p>The beep output level can be set in level set mode. (p. 12-6)</p>	

Beep Sound	1000Hz
<p>Sets the desired key-touch beep sound frequency within 500 to 2000 Hz in 10 Hz steps. (default: 1000 Hz)</p>	

Quick SPLIT	ON
<p>When this item is set to ON, pushing and holding <input type="checkbox"/> SPLIT for 1 sec. sets the unselected VFO's readout frequency to the selected VFO's readout frequency and activates split operation. (default: ON)</p> <p style="text-align: right;">See p. 6-7 for details.</p>	

■ Others set mode (continued)

FM SPLIT Offset(HF)	-0.100MHz
<p>Sets the offset (difference between transmit and receive frequencies) for the quick split function. This setting is used for HF bands in FM mode only and is used to input the repeater offset for an HF band.</p> <p>The offset frequency can be set from -9.999 MHz to +9.999 MHz in 1 kHz steps. (default: -0.100 MHz)</p>	
FM SPLIT Offset(50M)	-0.500MHz
<p>Sets the offset (difference between transmit and receive frequencies) for the quick split function. This setting is used for 50 MHz band FM mode only, and is used to input the repeater offset for the 50 MHz band.</p> <p>The offset frequency can be set from -9.999 MHz to +9.999 MHz in 1 kHz steps. (default: -0.500 MHz)</p>	
SPLIT LOCK	OFF
<p>When this item is ON, the main dial can be used to adjust the transmit frequency while pushing [XFC] even while the lock function is activated. (default: OFF)</p> <p>See pgs. 6-6, 6-7 for split frequency operation details.</p>	
Tuner (Auto Start)	OFF
<p>The internal antenna tuner has an automatic start capability which starts tuning if the SWR is higher than 1.5-3:1.</p>	<ul style="list-style-type: none"> • OFF : The tuner remains OFF even when the SWR is poor (1.5-3:1). (default) • ON : Automatic tune starts even when the tuner is turned OFF during HF bands operation.
Tuner (PTT Start)	OFF
<p>Tuning of the internal antenna tuner can be started automatically at the moment the PTT is pushed after the operating frequency is changed (more than 1% from last-tuned frequency). (default: OFF)</p>	

■ Others set mode (continued)

Transverter Function	Auto
Selects the transverter operation condition from Auto and ON. (default: Auto)	<ul style="list-style-type: none"> • ON : Turn the transverter operation ON. • Auto: The transceiver turns into transverter operation condition when 2 to 13.8 V DC is applied to [ACC2] pin 6.

Transverter Offset	16.000MHz (14.000.00→30.000.00)
Sets the desired offset frequency for the transverter operation within 0.000 to 99.999 MHz in 1 kHz steps. (default: 16.000 MHz)	

RTTY Mark Frequency	2125
Selects the RTTY mark frequency. RTTY mark frequency is switched between 1275, 1615 and 2125 Hz. (default: 2125 Hz)	
2125 Hz is automatically selected when the internal RTTY decoder is used.	

RTTY Shift Width	170
Selects the RTTY shift width. There are 3 selectable values: 170, 200 and 425 Hz. (default: 170 Hz)	
170 Hz is automatically selected when the internal RTTY decoder is used.	

RTTY Keying Polarity	Normal
Selects the RTTY keying polarity. Normal or reverse keying polarity can be selected. (default: Normal)	<p>When reverse polarity is selected, Mark and Space are reversed.</p> <ul style="list-style-type: none"> • Normal : Key open/close = Mark/Space • Reverse : Key open/close = Space/Mark

PSK Tone Frequency	1500
Selects the desired PSK tone frequency for the PSK reception from 1000, 1500 and 2000 Hz. (default: 1500 Hz)	

SPEECH Language	English
Selects the speech language from English and Japanese. (default: English)	

SPEECH Speed	HIGH
Selects the speech speed from HIGH (faster) and LOW (slower). (default: HIGH)	

■ Others set mode (continued)

SPEECH S-Level	ON
<p>The IC-7700 speech processor has frequency, mode and signal level announcement. Signal level announcement can be deactivated if desired. (default: ON)</p> <p>When "OFF" is selected, the signal level is not announced.</p>	
SPEECH [MODE] Switch	OFF
<p>Selects the operating mode speech capability when a mode switch is pushed; ON or OFF. (default: OFF)</p> <p>When "ON" is selected, the selected operating mode is announced when a mode switch is pushed.</p>	
Memopad Numbers	5
<p>Sets the number of memo pad channels available. 5 or 10 memo pads can be set. (default: 5)</p>	
MAIN DIAL Auto TS	HIGH
<p>Sets the auto tuning step function for the main dial. When rotating the main dial rapidly, the tuning step automatically changes several times as selected.</p> <p>There are 2 type of auto tuning steps: HIGH (Fastest) and LOW (Faster). (default: HIGH)</p> <ul style="list-style-type: none"> • HIGH : Auto tuning step is turned ON. Fastest tuning step during rapid rotation. (default) • LOW : Auto tuning step is turned ON. Faster tuning step during rapid rotation. • OFF : Auto tuning step is turned OFF. 	
MIC Up/Down Speed	HIGH
<p>Sets the rate at which frequencies are scanned when the microphone [UP]/[DN] switches are pushed and held. High or low can be selected.</p> <ul style="list-style-type: none"> • HIGH : High speed (default; 50 tuning steps/sec.) • LOW : Low speed (25 tuning steps/sec.) 	
Quick RIT/ΔTX Clear	OFF
<p>Selects the RIT/ΔTX frequency clearing instruction with the <input type="checkbox"/> CLEAR switch.</p> <ul style="list-style-type: none"> • ON : Clears the RIT/ΔTX frequency when <input type="checkbox"/> CLEAR is pushed momentarily. • OFF : Clears the RIT/ΔTX frequency when <input type="checkbox"/> CLEAR is pushed and held for 1 sec. (default) 	

■ Others set mode (continued)

<p>[NOTCH] Switch (SSB)</p> <p>Selects notch functions for SSB mode operation from Auto, Manual and Auto/Manual.</p>	<p>Auto/Manual</p> <ul style="list-style-type: none"> • Auto : Only the auto notch can be used. • Manual : Only the manual notch can be used. • Auto/Manual : Both the auto and manual notch can be used. (default)
<p>[NOTCH] Switch (AM)</p> <p>Selects notch functions for AM mode operation from Auto, Manual and Auto/Manual.</p>	<p>Auto/Manual</p> <ul style="list-style-type: none"> • Auto : Only the auto notch can be used. • Manual : Only the manual notch can be used. • Auto/Manual : Both the auto and manual notch can be used. (default)
<p>DIGI-SEL VR Operation</p> <p>Selects [DIGI-SEL] control function from DIGI-SEL and APF.</p>	<p>DIGI-SEL</p> <ul style="list-style-type: none"> • DIGI-SEL : [DIGI-SEL] control functions as the digital selector operation. (default) • APF : [DIGI-SEL] control functions as the audio peak filter adjustment.
<p>SSB/CW Synchronous Tuning</p> <p>Selects the displayed frequency shift function from ON and OFF. (default: OFF)</p> <p>When this function is activated, the audio pitch or tones of the received signal will remain the same even when the operating mode is changed between SSB and CW.</p> <p>/// The frequency shifting value may differ according to the CW pitch setting.</p>	<p>OFF</p> <ul style="list-style-type: none"> • ON : The displayed frequency shifts when the operating mode is changed between SSB and CW. • OFF : The displayed frequency does not shift.
<p>CW Normal Side</p> <p>Selects the side band used to receive CW in CW normal mode. (default: LSB)</p>	<p>LSB</p>
<p>APF Type</p> <p>Set audio filter shape for APF from SOFT and SHARP. (default: SOFT)</p>	<p>SHARP</p> <ul style="list-style-type: none"> • SOFT : Soft filter shape makes distinguishing noise and signals easier. The audio filter width is related to the CW pitch setting. • SHARP : Sharp filter shape rejects interference signals.

■ Others set mode (continued)

<p>External Keypad (VOICE)</p> <p>Sets the external keypad for voice message transmission capability ON and OFF.</p> <p>See page 2-7 for the equivalent circuit of an external keypad and connection.</p>	<p>OFF</p> <ul style="list-style-type: none"> • ON : Pushing one of external keypad switches, transmits the desired voice message contents during a phone mode operation. • OFF : External keypad does not function. (default)
<p>External Keypad (KEYER)</p> <p>Sets the external keypad for keyer memory transmission capability ON and OFF.</p> <p>See page 2-7 for the equivalent circuit of an external keypad and connection.</p>	<p>OFF</p> <ul style="list-style-type: none"> • ON : Pushing one of external keypad switches, transmits the desired keyer memory contents during CW mode operation. • OFF : External keypad does not function. (default)
<p>CI-V Baud Rate Auto</p> <p>Sets the CI-V data transfer rate. 300, 1200, 4800, 9600, 19200 bps and "Auto" are available. (default: Auto)</p> <p>When "Auto" is selected, the baud rate is automatically set according to the data rate of connected controller.</p>	
<p>CI-V Address 74h</p> <p>To distinguish equipment, each CI-V transceiver has its own Icom standard address in hexadecimal code. The IC-7700's address is 74h.</p> <p>When 2 or more IC-7700's are connected to an optional CT-17 CI-V LEVEL CONVERTER, rotate the main dial to select a different address for each IC-7700; the range is 01h to 7Fh.</p>	
<p>CI-V Transceive ON</p> <p>Transceive operation is possible with the IC-7700 connected to other Icom HF transceivers or receivers.</p> <p>When "ON" is selected, changing the frequency, operating mode, etc. on the IC-7700 automatically changes those of connected transceivers (or receivers) and vice versa.</p>	

■ Others set mode (continued)

RS-232C Function	CI-V
Select [RS-232C] connector output data format from CI-V and Decode.	<ul style="list-style-type: none"> • CI-V : Outputs data in CI-V format. (default) • Decode : Outputs decoded contents in ASCII code format.

Decode Baud Rate	9600
Selects data transmission speed (Baud rate) when "Decode" is selected in "RS-232C Function" above; settings are 300, 1200, 4800, 9600 and 19200 bps. (default: 9600)	

Keyboard Type	English
Selects the connected keyboard type from Japanese, English, United Kingdom, French, French (Canadian), German, Portuguese, Portuguese (Brazilian), Spanish, Spanish (Latin American) and Italian. (default: English)	

Keyboard Repeat Delay	250ms
Sets the time period for delay within 100 to 1000 msec. in 50 msec. steps. (default: 250 msec.)	
When a key of the connected keyboard is pressed and held for the set period, the character is input continuously.	

Keyboard Repeat Rate	10.9cps
Sets the repeating rate for the connected keyboard within 2.0 to 30.0 cps. (default: 10.9 cps) *cps=character per second	<ul style="list-style-type: none"> • Available repeating rate 2.0, 2.1, 2.3, 2.5, 2.7, 3.0, 3.3, 3.7, 4.0, 4.3, 4.6, 5.0, 5.5, 6.0, 6.7, 7.5, 8.0, 8.6, 9.2, 10.0, 10.9, 12.0, 13.3, 15.0, 16.0, 17.1, 18.5, 20.0, 21.8, 24.0, 26.7, 30.0
When a key of the connected keyboard is pressed and held, the character is repeatedly input with the set speed.	

IP Address (Valid after Reboot)	192. 168. 0. 1
Sets IP address for the IC-7700 when connecting to your PC or LAN (Local Area Network) through the Ethernet connector.	Turn the transceiver power OFF then ON to make the setting effective. See p. 16-7 for details.

Subnet Mask (Valid after Reboot)	255. 255. 255. 0 (24bit)
Sets subnet mask for the IC-7700 when connecting to your PC or LAN (Local Area Network) through the Ethernet connector.	Turn the transceiver power OFF then ON to make the setting effective. See p. 16-7 for details.

■ USB-Memory set menu

◇ USB-Memory set screen arrangement

- USB-Memory set menu

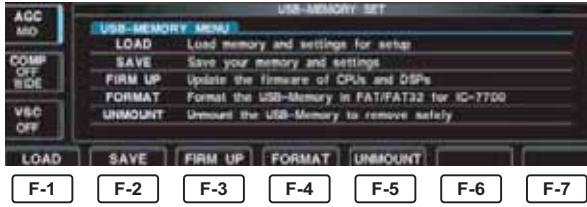

- Setting load screen (p. 12-23)



- Load option set mode (p. 12-21)



- Setting save screen (p. 12-22)



- Save option set mode (p. 12-20)



- Firmware update (p. 16-4)

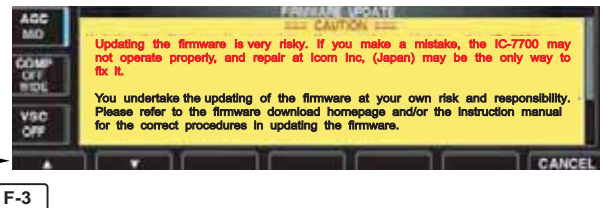

- Format menu (p. 12-26)



- Unmount USB-Memory (p. 12-25)



◇ Save option set mode

SAVE Contents	All
Selects file save condition from All and Select. (default: All)	<ul style="list-style-type: none">• All : Saves all the following contents.• Select : Saves the selected contents only.
Memory & Settings	YES
This setting is fixed "YES."	<ul style="list-style-type: none">• YES : Saves memory channel contents and settings of set modes.
Voice TX Memory	YES
Selects the voice TX message save condition from YES and NO. (default: YES)	<ul style="list-style-type: none">• YES : Saves the voice TX message.• NO : Does not save.
Voice RX Memory	NO
Selects the voice RX message save condition from YES and NO. (default: NO)	<ul style="list-style-type: none">• YES : Saves the voice RX message.• NO : Does not save.

◇ Load option set mode

Load Contents	Select
Selects file load condition from All and Select. (default: Select)	<ul style="list-style-type: none"> • All : Loads and sets the all following contents. • Select : Loads and sets the selected contents only.
ANT Memory	NO
Selects the antenna memory setting loading condition YES and NO. (default: NO).	<ul style="list-style-type: none"> • YES : Loads and sets the antenna memory. • NO : Use the original antenna memory setting.
REF IN/OUT, REF Adjust	NO
Selects the reference signal setting load condition YES and NO. (default: NO).	<ul style="list-style-type: none"> • YES : Loads and sets the reference signal setting. • NO : Use the original reference signal setting.
IP Address, Subnet Mask	NO
Selects the IP address and subnet mask setting load condition YES and NO. (default: NO).	<ul style="list-style-type: none"> • YES : Loads and sets the IP address and subnet mask setting. • NO : Use the original IP address and subnet mask setting.
CI-V Address	NO
Selects the CI-V address setting load condition YES and NO. (default: NO).	<ul style="list-style-type: none"> • YES : Loads and sets the CI-V address setting. • NO : Use the original CI-V address setting.
Other Memory & Settings	YES
Selects memory channel contents and other settings load condition YES and NO. (default: YES).	<ul style="list-style-type: none"> • YES : Loads and sets memory channel contents and other settings. • NO : Use the original memory channel contents and other settings.
Voice TX Memory	YES
Selects the voice TX message load condition YES and NO. (default: YES).	<ul style="list-style-type: none"> • YES : Loads and sets voice TX message. • NO : Use the original voice TX message.
Voice RX Memory	YES
Selects the voice RX message load condition YES and NO. (default: NO).	<ul style="list-style-type: none"> • YES : Loads and sets voice RX message. • NO : Use the original voice RX message.

■ File saving

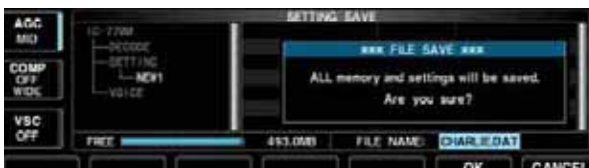
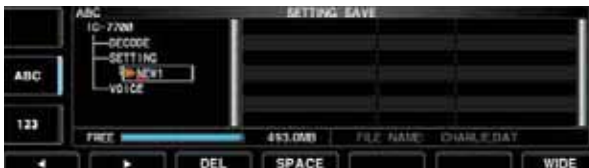
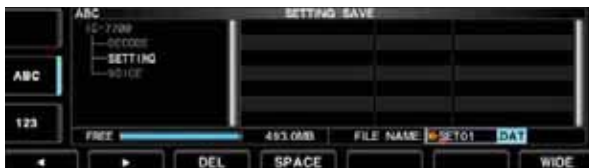
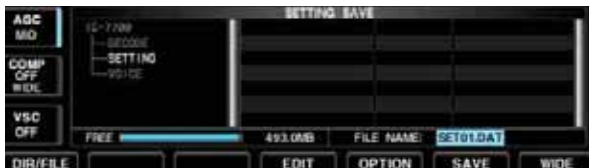
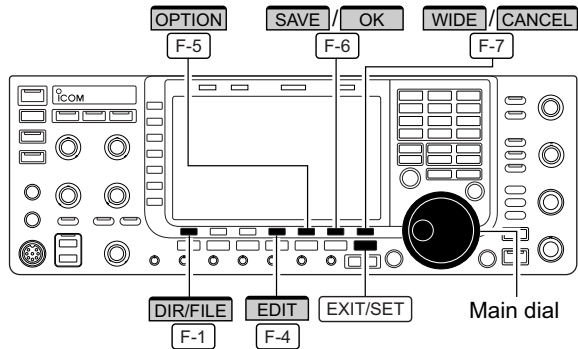

Memory channel contents, set mode settings, etc. can be saved into the USB-Memory for backup.

- ① During set mode menu screen indication, push [USB] [F-7] to select USB-Memory set menu screen.
- ② Push [SAVE] [F-2] to select setting save screen.
- ③ Change the following conditions if desired.

• **File name:**

- ① Push [EDIT] [F-4] to select file name edit condition.
 - Push [DIR/FILE] [F-1] several times to select the file name, if necessary.
- ② Push [ABC] (MF6), [123] (MF7) or [Symbol] (MF7) to select the character group, then rotate the main dial to select the character.
 - [ABC] (MF6): A to Z (capital letters); [123] (MF7): 0 to 9 (numerals); [Symbol] (MF7): ! # \$ % & ' ` ^ + - = () [] { } _ ~ @ can be selected.
 - Push [◀] [F-1] to move the cursor left, push [▶] [F-2] to move the cursor right, push [DEL] [F-3] to delete a character and push [SPACE] [F-4] to insert a space.
- ③ Push [EXIT/SET] to set the file name.

• **Save option**

- ① Push [OPTION] [F-5] to enter save option set mode.
- ② Push [▲] [F-1] or [▼] [F-2] to select the item, then rotate the main dial to select the desired setting. (see p. 12-20 for details)
 - "Text" is the default setting.
 - Push and hold [DEF] [F-4] for 1 sec. to select the default setting.
- ③ Push [EXIT/SET] to return to the previous indication.

• **Saving location**

- ① Push [DIR/FILE] [F-1] to select tree view screen.
- ② Select the desired directory or folder in the USB-Memory.
 - Push [◀▶] [F-4] to select the upper directory.
 - Push [▲] [F-2] or [▼] [F-3] to select folder in the same directory.
 - Push and hold [◀▶] [F-4] for 1 sec. to select a folder in the directory.
 - Push [REN/DEL] [F-5] to rename the folder.
 - Push and hold [REN/DEL] [F-5] for 1 sec. to delete the folder.
 - Push and hold [MAKE] [F-6] for 1 sec. to making a new folder. (Edit the name with the same manner as the "• File name" above.)
- ③ Push [DIR/FILE] [F-1] twice to select the file name.

- ④ Push [SAVE] [F-6].
 - Confirmation screen appears.
- ⑤ Push [OK] [F-6] to save.
 - After saving is completed, return to USB-Memory set menu automatically.

■ File loading

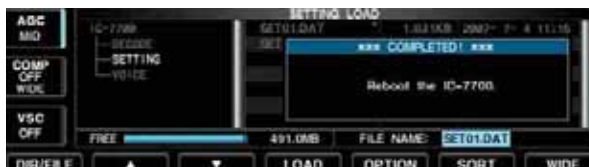
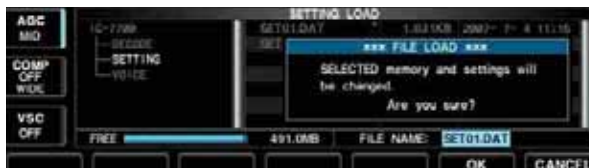
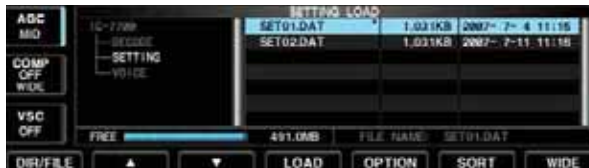
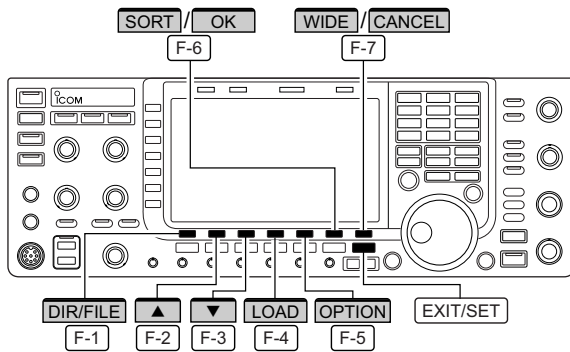

By loading the saved setting file from the USB-Memory, you can easily set up another IC-7700—several operators settings can easily be applied to one IC-7700.

- ① During set mode menu screen indication, push [USB] [F-7] to select USB set menu screen.
- ② Push [LOAD] [F-1] to select setting load screen.
 - The indicator above the USB connectors and “USB” indicator on the display blink.
 - After the USB-Memory contents are displayed, the indicators stop blinking.
- ③ Push [OPTION] [F-5] to select load option set mode, then set the desired loading conditions, if desired.
 - See page 12-21 for details.
- ④ Push [▲] [F-2] or [▼] [F-3] to select the desired setting file.
- ⑤ Push [LOAD] [F-4].
 - Confirmation screen appears.
- ⑥ Push [OK] [F-6] to starts loading.
 - After the loading is completed, the message dialog, “Reboot the IC-7700,” appears.
- ⑦ Turn the transceiver power OFF then ON to make the setting effective.

■ Changing a file name

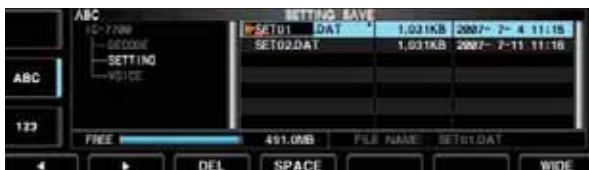
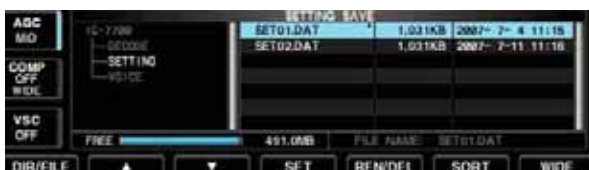
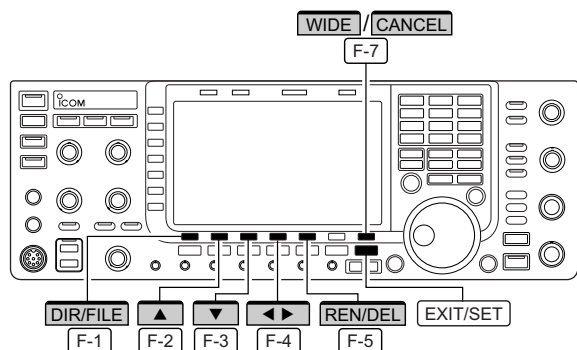

The file name, saved in the USB-Memory, can be re-named from the transceiver as desired.

- ① During setting save screen display, push [DIR/FILE] **F-1** to select tree view screen.
 - Push [▲] **F-2** or [▼] **F-3** to select the desired folder.
 - “DECODE,” “SETTING” and “VOICE” folders are available as the default.
 - After the folder is selected, push and hold [◀▶] **F-4** for 1 sec. to display content folder(s), if available.
- ② Push [DIR/FILE] **F-1** to select file list screen.
- ③ Push [▲] **F-2** or [▼] **F-3** to select the desired file.
- ④ Push [REN/DEL] **F-5** momentarily to select the file name edit condition.
- ⑤ Push [ABC] (MF6), [123] (MF7) or [Symbol] (MF7) to select the character group, then rotate the main dial to select the character.
 - [ABC] (MF6): A to Z (capital letters); [123] (MF7): 0 to 9 (numerals); [Symbol] (MF7): ! # \$ % & ' ` ^ + - = () [] { } _ ~ @ can be selected.
 - Push [◀] **F-1** to move the cursor left, push [▶] **F-2** to move the cursor right, push [DEL] **F-3** to delete a character and push [SPACE] **F-4** to insert a space.
 - Pushing the transceiver’s keypad, [0]–[9], can also enter numerals.
- ⑥ Push [EXIT/SET] to set the file name.

■ Deleting a file



RECOMMENDATION! Deleting the setting file is irreversible. Confirm the contents before deleting a setting file!

- ① During setting save screen display, push [DIR/FILE] [F-1] to select tree view screen.
 - Push [▲] [F-2] or [▼] [F-3] to select the desired folder.
 - “DECODE,” “SETTING” and “VOICE” folders are available as the default.
 - After the folder is selected, push and hold [◀ ▶] [F-4] for 1 sec. to display content folder(s), if available.
- ② Push [DIR/FILE] [F-1] to select file list screen.
- ③ Push [▲] [F-2] or [▼] [F-3] to select the desired file to be deleted.
- ④ Push and hold [REN/DEL] [F-5] for 1 sec.
 - Confirmation screen appears.
- ⑤ Push [OK] [F-6] to delete.
 - After the deleting, return to setting save screen automatically.

■ Unmounting USB-Memory



CAUTION! When removing the USB-Memory, unmount operation is necessary. If you do not unmount the memory in this case, data in the USB memory may be corrupted.

- ① Push and hold [UNMOUNT] [F-6] for 1 sec.
 - Confirmation screen appears.
- ② Push [OK] [F-6] to unmount the USB-Memory.
- ③ After “USB” indication disappears, remove the USB-Memory.

■ Formatting the USB-Memory



Saved data in the USB-Memory can be erased.

IMPORTANT! Formatting erases all saved data in the USB-Memory. Making a backup file on your PC is recommended.

- ① During USB-Memory set menu display, push and hold [FORMAT] [F-4] for 1 sec.
 - Confirmation screen appears.
- ② Push [FAT] [F-6] or [FAT32] [F-7] to select the format type, FAT or FAT32, respectively.
 - Confirmation screen appears.
- ③ Push [OK] [F-6] to format.
 - Push [CANCEL] [F-7] to cancel.
- ④ Returns to USB-Memory set menu indication automatically.

NOTE: If no USB-Memory is inserted and [FORMAT] [F-4] is selected as in step ①, an error message appears.

■ Troubleshooting	13-2
◇ Transceiver power	13-2
◇ Transmit and receive	13-2
◇ Scanning	13-3
◇ Display	13-3
◇ Format USB-Memory	13-3
■ Main dial brake adjustment	13-3
■ SWR reading	13-4
■ Screen type and font selections	13-4
■ Frequency calibration (approximate)	13-5
■ Opening the transceiver's case	13-6
■ Clock backup battery replacement	13-6
■ Fuse replacement	13-7
■ Resetting the CPU	13-7
■ About protection indications	13-8
■ Screen Saver Function	13-8

■ Troubleshooting

The following chart is designed to help you correct problems which are not equipment malfunctions. If you are unable to locate the cause of a problem or solve it through the use of this chart, contact your nearest Icom Dealer or Service Center.

◇ Transceiver power

PROBLEM	POSSIBLE CAUSE	SOLUTION	REF.
Power does not come on when the [POWER] switch is pushed.	<ul style="list-style-type: none"> • Power cable is improperly connected. • The internal power supply is turned OFF. • Circuit breaker is tripped. 	<ul style="list-style-type: none"> • Re-connect the AC power cable correctly. • Turn the internal power supply ON. • Check for the cause, then re-set the circuit breaker. 	<p>p. 2-5 p. 3-2 —</p>

◇ Transmit and receive

PROBLEM	POSSIBLE CAUSE	SOLUTION	REF.
No sounds from the speaker.	<ul style="list-style-type: none"> • Volume level is too low. • The squelch is closed. • The transceiver is in transmit. 	<ul style="list-style-type: none"> • Rotate [AF] clockwise to obtain a suitable listening level. • Turn [SQL] to 10 o'clock position to open the squelch. • Push [TRANSMIT] to receive or check the SEND line of an external unit, if connected. 	<p>p. 3-9 p. 3-9 p. 3-12</p>
Sensitivity is too low, and only strong signals are audible.	<ul style="list-style-type: none"> • The antenna is not connected properly. • The antenna for another band is selected. • The antenna is not properly tuned. • The attenuator is activated. 	<ul style="list-style-type: none"> • Re-connect to the antenna connector. • Select an antenna suitable for the operating frequency. • Push and hold [TUNER] for 1 sec. to manually tune the antenna. • Push [ATT] (MF4) several times to select "ATT OFF." 	<p>— p. 10-2 p. 10-6 p. 5-9</p>
Received audio is unclear or distorted.	<ul style="list-style-type: none"> • Wrong operating mode is selected. • PBT function is activated. • Noise blanker is turned ON when receiving a strong signal. • Preamp is activated. • The noise reduction is activated and the [NR] control is too far clockwise. 	<ul style="list-style-type: none"> • Select a suitable operating mode. • Push and hold [PBT-CLR] for 1 sec. to reset the function. • Push [NB] to turn the noise blanker OFF. • Push [P.AMP] (MF3) once or twice to turn the function OFF. • Set the [NR] control for maximum readability. 	<p>p. 3-8 p. 5-12 p. 5-16 p. 5-9 p. 5-17</p>
The [ANT] switch does not function	<ul style="list-style-type: none"> • The antenna switch has not been activated. 	<ul style="list-style-type: none"> • Set the antenna switch in set mode to "Auto" or "Manual." 	p. 10-4
Transmitting is impossible.	<ul style="list-style-type: none"> • The operating frequency is not inside a ham band. 	<ul style="list-style-type: none"> • Set the frequency to be in a ham band. 	p. 3-5
Output power is too low.	<ul style="list-style-type: none"> • [RF PWR] is set too far counterclockwise • [DRIVE] is set too far counterclockwise • [MIC] is set too far counterclockwise • The antenna for another band is selected. • The antenna is not properly tuned. 	<ul style="list-style-type: none"> • Rotate [RF PWR] clockwise. • Set [DRIVE] to a suitable position. • Set [MIC] to a suitable position. • Select an antenna suitable for the operating frequency. • Push and hold [TUNER] for 1 sec. to manually tune the antenna. 	<p>p. 3-12 p. 3-13 p. 3-12 p. 10-2 p. 10-6</p>
No contact possible with another station.	<ul style="list-style-type: none"> • RIT or ΔTX function is activated. • Split frequency function is activated. 	<ul style="list-style-type: none"> • Push [RIT] or [ΔTX] to turn the function OFF. • Push [SPLIT] to turn the function OFF. 	<p>pgs. 5-10, 6-4 p. 6-6</p>
Transmit signal is unclear or distorted.	<ul style="list-style-type: none"> • [MIC] is set too far clockwise 	<ul style="list-style-type: none"> • Set [MIC] to a suitable position. 	p. 3-12
Repeater cannot be accessed.	<ul style="list-style-type: none"> • Split frequency function is not activated. • Programmed subaudible tone frequency is wrong. 	<ul style="list-style-type: none"> • Push [SPLIT] to turn the function ON • Reset the frequency using set mode. 	<p>p. 6-6 p. 4-33</p>

◇ Scanning

PROBLEM	POSSIBLE CAUSE	SOLUTION	REF.
Programmed scan does not stop.	• Squelch is open.	• Set [SQL] to the threshold point.	p. 3-9
Programmed scan does not start.	• The same frequencies have been programmed in scan edge memory channels P1 and P2.	• Program different frequencies in scan edge memory channel P1 and P2.	p. 8-3
Memory scan does not start	• 2 or more memory channels have not been programmed.	• Program more than 2 memory channels.	p. 8-3
Select memory scan does not start	• 2 or more memory channels have not been designated as select channels.	• Designate more than 2 memory channels as select channels for the scan.	p. 9-7

◇ Display

PROBLEM	POSSIBLE CAUSE	SOLUTION	REF.
The displayed frequency does not change properly.	• The dial lock function is activated. • A set mode screen is selected. • The internal CPU has malfunctioned.	• Push [LOCK] to turn the function OFF. • Push [EXIT/SET] several times to exit the set mode screen. • Reset the CPU.	p. 5-17 p. 12-2 p. 13-7

◇ Format USB-Memory

PROBLEM	POSSIBLE CAUSE	SOLUTION	REF.
Format error appears when formatting in FAT32	• The inserted USB-Memory capacity is smaller than 64 MB.	• Insert a USB-Memory larger than 64 MB or select the FAT format.	p. 12-26
Format error appears when formatting in FAT	• The inserted USB-Memory capacity is larger than 2 GB.	• Insert a USB-Memory smaller than 2 GB or select the FAT32 format.	p. 12-26

■ Main dial brake adjustment

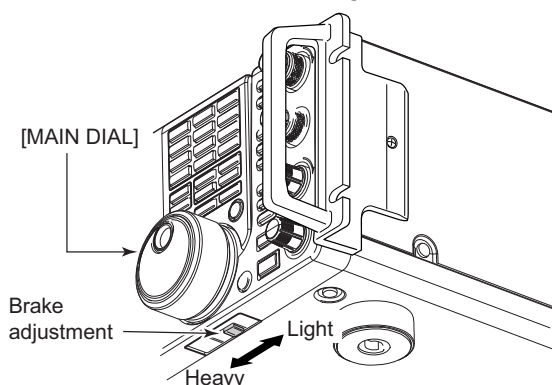

The tension of the main dial may be adjusted to suit your preference.

The brake adjustment is located on the bottom side of the front panel. See the figure at left.

Slide the brake adjustment to a comfortable tension level while turning the dial continuously and evenly in one direction.

SWR reading

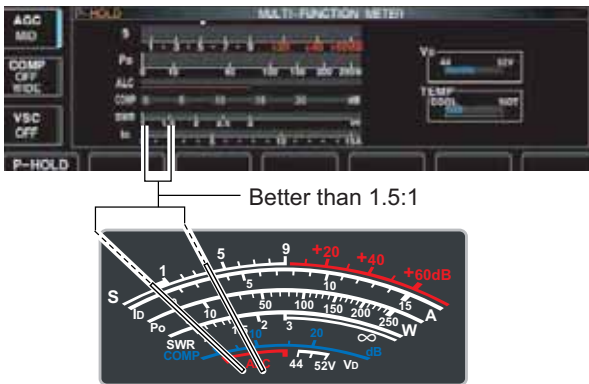
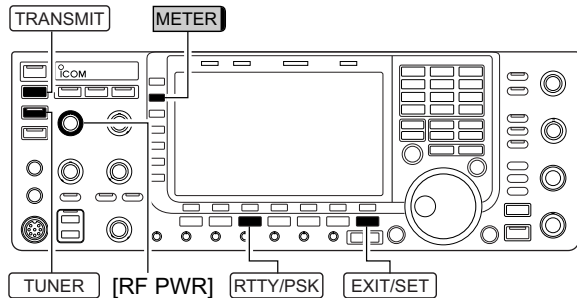

The SWR meter indicates the SWR over the transmission line in all modes.

- ① Push **[TUNER]** to turn the antenna tuner OFF.
- ② Push and hold **[METER]** for 1 sec. to display multi-function meter.
- ③ Push **[RTTY/PSK]** once or twice to select RTTY mode.
- ④ Push **[TRANSMIT]**.
- ⑤ Rotate **[RF PWR]** clockwise past the 12 o'clock position for more than 30 W output power.
- ⑥ Read the SWR on the SWR meter gage.
- ⑦ Push **[EXIT/SET]** to close multi-function meter.

▨ The built-in antenna tuner matches the transmitter to the antenna when the SWR is lower than 3 : 1.

Screen type and font selections

- Screen image example—
Display Type: B, Display Font: Slim



2 types of screen images and 5 types of frequency readout indication fonts are available in the IC-7700.

- ① Push **[EXIT/SET]** several times to close multi-function screen, if necessary.
- ② Push **[SET] [F-7]** to select set mode menu screen.
- ③ Push **[DISP] [F-3]** to enter display set mode.
- ④ Push **[▲] [F-1]** or **[▼] [F-2]** to select “Display Type” item when selecting the screen image, select “Display Font” when selecting the frequency readout indication font.
- ⑤ Rotate the main dial to select the desired screen image or font.
 - Screen image is selectable from A (Black back) and B (Blue back).
 - Basic (1), Basic (2), Italic, Round and Slim are available for the frequency readout font.
- ⑥ Push **[EXIT/SET]** twice to exit from display set mode.

■ Frequency calibration (approximate)

A very accurate frequency counter is required to calibrate the frequency of the transceiver. However, a rough check may be performed by receiving radio station WWV, WWVH, or other standard frequency signals.

CAUTION: The IC-7700 has been thoroughly adjusted and tested at the factory before being shipped. You should not have to re-calibrate it.

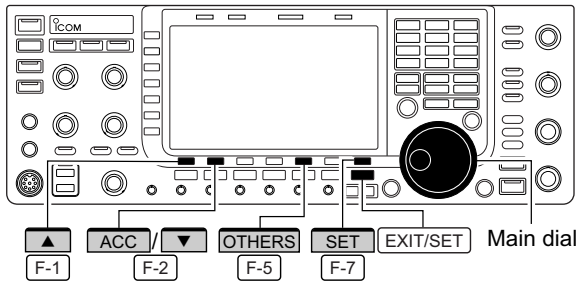

• Calibration marker item



• REF Adjust item



- ① Push **[SSB]** to select USB mode.
- ② Push and hold **[PBT-CLR]** for 1 sec. to clear the PBT setting and make sure that the RIT/ Δ TX function is not activated.
- ③ Set the frequency to the standard frequency station minus 1 kHz.
 - When receiving WWV or WWVH (at 15.00000 MHz) as a standard frequency, set the operating frequency for 14.99900 MHz.
 - Other standard frequencies can be used.
- ④ Push **[EXIT/SET]** several times to close a multi-function screen, if necessary.
- ⑤ Push **[SET] [F-7]** to select set mode menu screen.
- ⑥ Push **[OTHERS] [F-5]** to enter Others set mode.
- ⑦ Push **[Δ] [F-1]** several times to select the "Calibration Marker" item.
- ⑧ Rotate the main dial clockwise to turn the calibration marker ON.
- ⑨ Push **[EXIT/SET]** once to return to set mode menu screen.
- ⑩ Push **[ACC] [F-2]** to enter accessory set mode.
- ⑪ Push **[∇] [F-2]** several times to select the "REF Adjust" item.
- ⑫ Rotate the main dial to adjust for a zero beat with the received standard signal as shown at left.
 - Zero beat means that two signals are exactly the same frequency, resulting in a single tone being emitted.
- ⑬ Turn the calibration marker OFF in Others set mode.
- ⑭ Push **[EXIT/SET]** twice to exit set mode.

■ Opening the transceiver's case

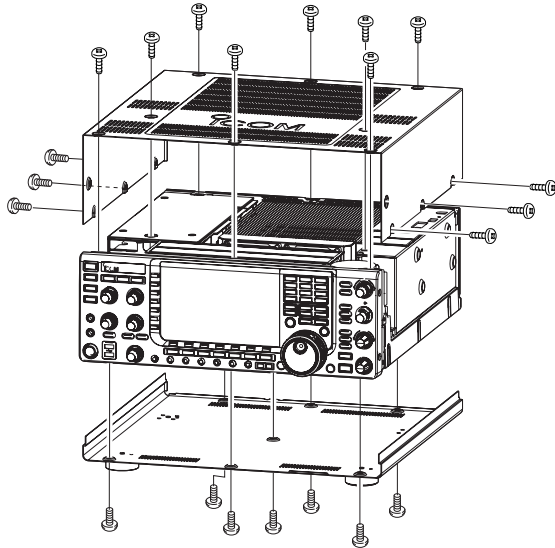

Follow the case opening procedures shown here when you want to replace the clock backup battery or internal fuse.

CAUTION! **DISCONNECT** the AC power cable from the transceiver before performing any work on the transceiver. Otherwise, there is danger of electric shock and/or equipment damage.

CAUTION! The transceiver weighs approx. 24 kg (53 lb). Always have two people available to lift or turn over the transceiver.

- ① Remove the rack mounting handle from both side. See p. 2-3 for rack mounting handle detachment details.
- ② Remove the 8 screws from the top of the transceiver and the 6 screws from the sides, then lift up the top cover.
- ③ Turn the transceiver upside-down.

CAUTION: NEVER HOLD THE MAIN DIAL OR ANY OTHER KNOBS when the transceiver is being turned upside down. This may damage the transceiver.

- ④ Remove 7 screws from the bottom, then lift up the bottom cover.

■ Clock backup battery replacement

The IC-7700 has a lithium backup battery (CR2032) inside for clock and timer functions. The usual life of the backup battery is approximately 2 years.

When the backup battery is discharged, the transceiver transmits and receives normally but cannot retain the current time.

WARNING: **DISCONNECT** the AC power cable from the AC outlet before removing the transceiver's cover.

- ① Remove the top cover as shown above.
- ② Replace the clock backup battery, located on the front panel as illustrated at left.
 - Make sure the battery polarity is correct.
- ③ Return the top cover to the original position.
- ④ Set the date and time in time set mode. (p. 11-2)

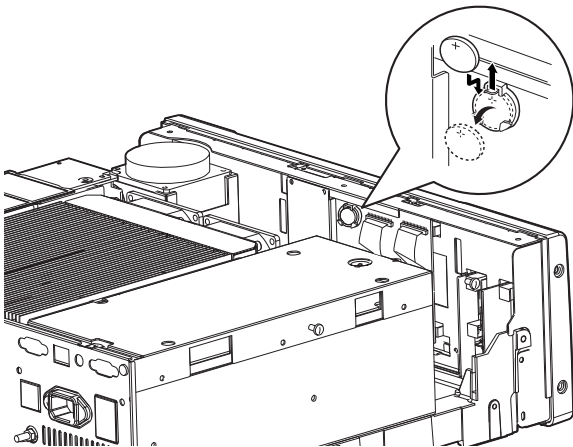

■ Fuse replacement

When no external DC output is available from [EXT DC] and ACC connectors, the internal fuse may be open. Replace the fuse in this case.

WARNING: DISCONNECT the AC power cable from the AC outlet before removing the transceiver's cover.

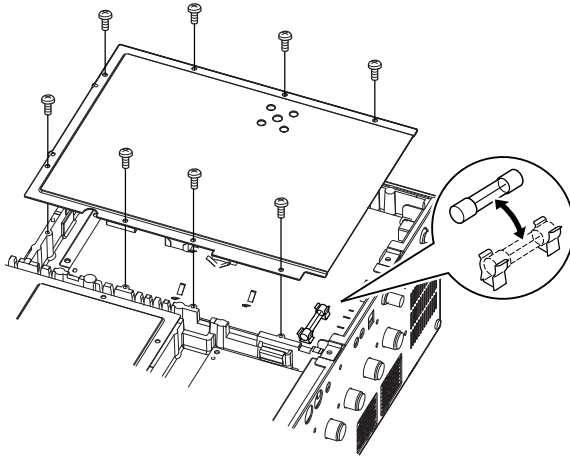

- ① Remove the bottom cover as shown left.
- ② Remove the 8 screws from the shield cover of the transceiver's bottom side.
- ③ Replace the open fuse with a new, properly rated one (FGB 2 A) as shown at left.
- ④ Return the inside cover and bottom cover and screws to the original position.

■ Resetting the CPU

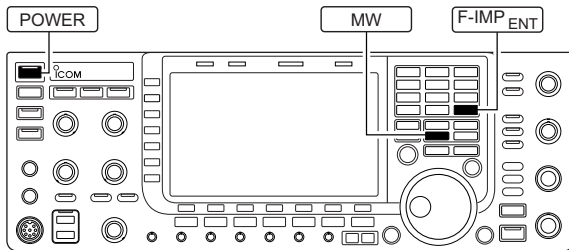

- ① Turn the main power switch on the rear panel ON.
 - Make sure the transceiver power is still OFF.
- ② While pushing and holding [F-IMP ENT] and [MW], push [POWER] to turn power ON.
 - The internal CPU is reset.
 - The CPU start-up takes approx. 5 sec.
 - The transceiver displays its initial VFO frequencies when resetting is complete.
- ③ Correct the set mode settings after resetting, if desired.

NOTE: Resetting **CLEARs** all programmed contents in memory channels and returns programmed values in set mode to default values.



■ About protection indications



Check the temperature

The IC-7700 has a 2-step protection function to protect the final power amplifiers.

The protector monitors the power amplifier temperature and activates when the temperature becomes extremely high.

- **Power down transmission**

Reduces the transmit output power to 100 W. “LMT” appears beside the transmit indicator during transmit.

- **Transmission inhibit**

Deactivates the transmitter. The transmit indicator is displayed in gray during transmit.

When the protector is activated, wait until the power amplifier cools down using the transceiver in stand-by or receive condition.

NOTE: DO NOT turn the transceiver power OFF when the protector is ON. If you do, the cooling fan will not function and it will take longer to cool the transceiver.

The power amplifier temperature can be monitored in the multi-function meter, TEMP gauge.

■ Screen saver function

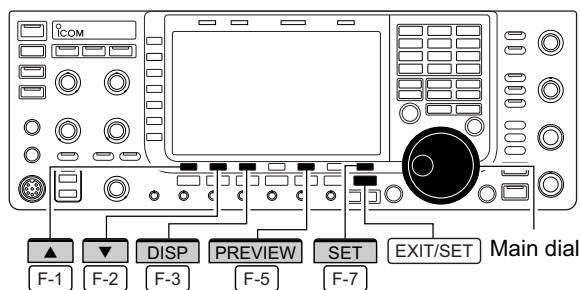

The IC-7700 has a screen saver function to protect the LCD from the “burn-in” effect.

- ① Push [EXIT/SET] several times to close a multi-function screen, if necessary.
- ② Push [SET] [F-7] to select set mode menu screen.
- ③ Push [DISP] [F-3] to enter display set mode.
- ④ Push [▲] [F-1] or [▼] [F-2] several times to select the “Screen Saver Function” item.
- ⑤ Rotate the main dial to select the desired time period for the screen saver activation from 15, 30, 60 min. and OFF.
 - Deactivate the screen saver with “OFF” selection.
- ⑥ Push [▼] [F-2] to select the “Screen Saver Type” item.
- ⑦ Rotate the main dial to select the screen saver type from “Bound,” “Rotation” and “Twist.”
 - Push and hold [PREVIEW] [F-5] to display the indication for your reference.
- ⑧ Push [EXIT/SET] twice to exit set mode.

- Remote jack (CI-V) information 14-2
 - ◇ CI-V connection example 14-2
 - ◇ Data format 14-2
 - ◇ Command table 14-3
 - ◇ To send/read memory contents 14-9
 - ◇ Band stacking register 14-9
 - ◇ Codes for memory keyer contents 14-9
 - ◇ Codes for memory name, opening message
and CLOCK2 name contents 14-9
 - ◇ Offset frequency setting 14-10
 - ◇ Repeater tone/tone squelch frequency setting 14-10
 - ◇ SSB transmission passband width setting 14-10
 - ◇ Color setting 14-10
 - ◇ Bandscope edge frequency setting 14-10
 - ◇ Data mode with filter width setting 14-10
 - ◇ Antenna memory setting 14-10

Remote jack (CI-V) information

CI-V connection example

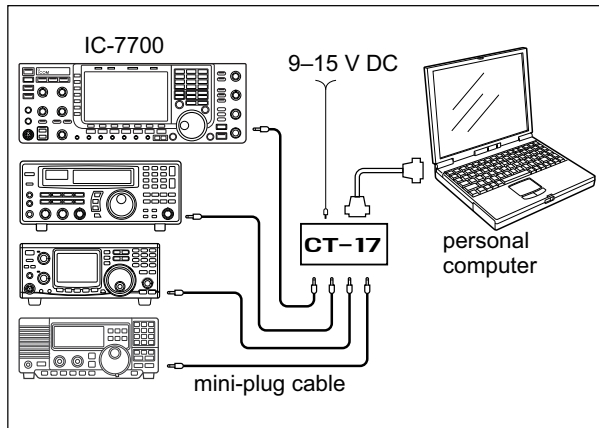

The transceiver can be connected through an optional CT-17 CI-V LEVEL CONVERTER to a PC equipped with an RS-232C port. The Icom Communications Interface-V (CI-V) controls the transceiver.

Up to 4 Icom CI-V transceivers or receivers can be connected to a PC equipped with an RS-232C port. See p. 12-17 for setting the CI-V condition using set mode.

Data format

The CI-V system can be operated using the following data formats. Data formats differ according to command numbers. A data area or sub command is added for some commands.

Controller to IC-7700

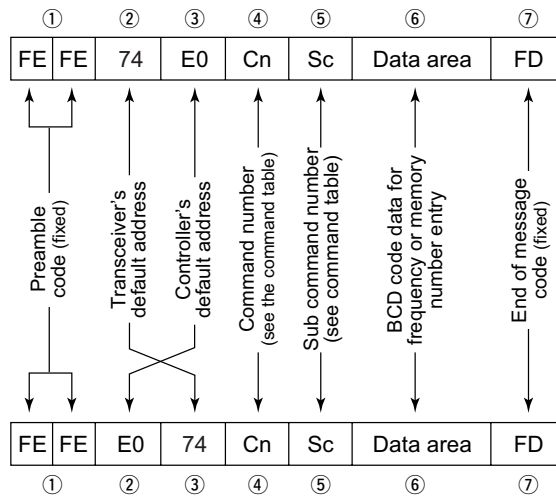

IC-7700 to controller

OK message to controller

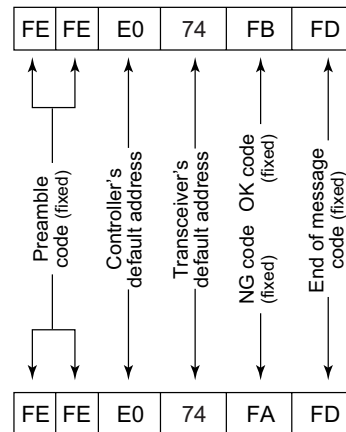

NG message to controller

◇ Command table

Command	Sub command	Description
00	—	Send frequency data
01	Same as command 06	Send mode data
02	—	Read band edge frequencies
03	—	Read operating frequency
04	—	Read operating mode
05	—	Set operating frequency
06	00 01 02 03 04 05 07 08 12 13	Select LSB Select USB Select AM Select CW Select RTTY Select FM Select CW-R Select RTTY-R Select PSK Select PSK-R
07	— 00 01 A0 B0	Select VFO mode Select VFO-A Select VFO-B Equalize VFO-A and VFO-B Exchange VFO-A and VFO-B
08	— 0001–0101*	Select memory mode Select memory channel *P1=0100, P2=0101
09	—	Memory write
0A	—	Memory to VFO
0B	—	Memory clear
0E	00 01 02 03 12 13 22 23 A1–A7 B0 B1 B2 D0 D3	Scan stop Programmed/memory scan start Programmed scan start Δ F scan start Fine programmed scan start Fine Δ F scan start Memory scan start Select memory scan start Set Δ F scan span (A1=±5 kHz; A2=±10 kHz; A3=±20 kHz; A4=±50 kHz; A5=±100 kHz; A6=±500 kHz; A7=±1 MHz) Set as non-select channel Set as select channel (1=★1; 2=★2; 3=★3; when no data command is specified, the previously set number or “★1” is selected) Set the number for select memory scan (0=ALL; 1=★1; 2=★2; 3=★3) D0 Set scan resume OFF D3 Set scan resume ON
0F	00 01	Turn the split function OFF Turn the split function ON
10	00 01 02 03 04 05 06 07 08	Select 10 Hz (1 Hz) tuning step Select 100 Hz tuning step Select 1 kHz tuning step Select 5 kHz tuning step Select 9 kHz tuning step Select 10 kHz tuning step Select 12.5 kHz tuning step Select 20 kHz tuning step Select 25 kHz tuning step

Command	Sub command	Description
11	—	Select/read attenuator (0=OFF; 1=6 dB; 2=12 dB; 3=18 dB)
12	00 + RX ANT 01 + RX ANT 02 + RX ANT 03 + RX ANT	Select/read ANT1 selection (00=RX ANT OFF; 01=RX ANT ON) Select/read ANT2 selection (00=RX ANT OFF; 01=RX ANT ON) Select/read ANT3 selection (00=RX ANT OFF; 01=RX ANT ON) Select/read ANT4 selection (00=RX ANT OFF; 01=RX ANT ON)
13	00 01 02	Announce with voice synthesizer (00=all data; 01=frequency and S-meter level; 02=receive mode)
14	01 + Level data 02 + Level data 03 + Level data 05 + Level data 06 + Level data 07 + Level data 08 + Level data 09 + Level data 0A + Level data 0B + Level data 0C + Level data 0D + Level data 0E + Level data 0F + Level data 11 + Level data 12 + Level data 13 + Level data 14 + Level data 15 + Level data 16 + Level data 17 + Level data	[AF] level setting (0=max. CCW to 255=max. CW) [RF] level setting (0=max. CCW to 255=11 o'clock) [SQL] level setting (0=11 o'clock to 255=max. CW) [APF] level setting (0=Pitch–550 Hz, 128=Pitch, 255=Pitch+550 Hz; 10 Hz steps) [NR] level setting (0=min. to 255=max.) Inside [TWIN PBT] setting or IF shift setting (0=max. CCW, 128=center, 255=max. CW) Outside [TWIN PBT] setting (0=max. CCW, 128=center, 255=max. CW) [CW PITCH] setting (0=300 Hz, 128=600 Hz, 255=900 Hz; 5 Hz steps) [RF POWER] setting (0=max. CCW to 255=max. CW) [MIC] setting (0=max. CCW to 255=max. CW) [KEY SPEED] setting (0=max. CCW to 255=max. CW) [NOTCH] setting (0=low freq. to 255=high freq.) [COMP] setting (0=max. CCW to 255=max. CW) [DELAY] setting (0=max. CCW to 255=max. CW) [AGC] control setting (0=max. CCW to 255=max. CW) [NB] control setting (0=max. CCW to 255=max. CW) [DIGI-SEL] setting (0=max. CCW to 255=max. CW) [DRIVE] setting (0=max. CCW to 255=max. CW) [MONI GAIN] setting (0=max. CCW to 255=max. CW) [VOX GAIN] setting (0=max. CCW to 255=max. CW) [ANTI VOX] setting (0=max. CCW to 255=max. CW)

14 CONTROL COMMAND

◇ Command table (continued)

Command	Sub command	Description
14	18 + Level data 19 + Level data	[CONTRAST] setting (0=max. CCW to 255=max. CW) [BRIGHT] setting (0=max. CCW to 255=max. CW)
15	01 02 11 12 13 14 15 16	Read squelch condition Read S-meter level Read RF power meter Read SWR meter Read ALC meter Read COMP meter Read V _D meter Read I _D meter
16	02 12 22 32 40 41 42 43 44 45 46 47 48 4C 4D 4E 4F 50 53	Send/read Preamp setting (0=OFF; 1=preamp 1; 2=preamp 2) Send/read AGC selection (0=OFF; 1=Slow; 2=Mid; 3=Fast) Send/read noise blanker setting (0=OFF; 1=ON) Send/read Audio peak filter setting for CW mode (APF type=SHARP: 0=OFF; 1=320 Hz; 2=160 Hz; 3=80 Hz, APF type=SOFT: 0=OFF; 1=WIDE; 2=MID; 3=NAR) Send/read noise reduction setting (0=OFF; 1=ON) Send/read auto notch setting (0=OFF; 1=ON) Send/read repeater tone setting (0=OFF; 1=ON) Send/read tone squelch setting (0=OFF; 1=ON) Send/read speech compressor setting (0=OFF; 1=ON) Send/read monitor setting (0=OFF; 1=ON) Send/read VOX function setting (0=OFF; 1=ON) Send/read Break-in function setting (0=OFF; 1=semi break-in; 2=full break-in) Send/read manual notch setting (0=OFF; 1=ON) Send/read VSC setting (0=OFF; 1=ON) Send/read Manual AGC setting (0=OFF; 1=ON) Send/read DIGI-SEL setting (0=OFF; 1=ON) Send/read twin peak filter setting (0=OFF; 1=ON) Send/read dial lock function setting (0=OFF; 1=ON) Send/read RX antenna connector setting (0=OFF; 1=ON)
19	00	Read the transceiver ID
1A	00 01 02	Send/read memory contents (see p. 14-9 for details) Send/read band stacking register contents (see p. 14-9 for details) Send/read memory keyer contents (see p. 14-9 for details)

Command	Sub command	Description
1A	03 04	Send/read the selected filter width (SSB, CW, PSK: 0=50 Hz to 40=3600 Hz; RTTY: 0=50 Hz to 31=2700 Hz; AM: 0=200 Hz to 49=10 kHz) Send/read the selected AGC time constant (0=OFF, 1=0.1/0.3 sec. to 13=6.0/8.0 sec.)
	050001	Send/read SSB RX HPF/LPF (HPF: 0=Through, 1=100 to 20=2000, LPF: 5=500 to 24=2400, 25=Through)
	050002	Send/read SSB RX Tone (Bass) level (0=-5 to 10=+5)
	050003	Send/read SSB RX Tone (Treble) level (0=-5 to 10=+5)
	050004	Send/read AM RX HPF/LPF (HPF: 0=Through, 1=100 to 20=2000, LPF: 5=500 to 24=2400, 25=Through)
	050005	Send/read AM RX Tone (Bass) level (0=-5 to 10=+5)
	050006	Send/read AM RX Tone (Treble) level (0=-5 to 10=+5)
	050007	Send/read FM RX HPF/LPF (HPF: 0=Through, 1=100 to 20=2000, LPF: 5=500 to 24=2400, 25=Through)
	050008	Send/read FM RX Tone (Bass) level (0=-5 to 10=+5)
	050009	Send/read FM RX Tone (Treble) level (0=-5 to 10=+5)
	050010	Send/read CW RX HPF/LPF (HPF: 0=Through, 1=100 to 20=2000, LPF: 5=500 to 24=2400, 25=Through)
	050011	Send/read RTTY RX HPF/LPF (HPF: 0=Through, 1=100 to 20=2000, LPF: 5=500 to 24=2400, 25=Through)
	050012	Send/read PSK RX HPF/LPF (HPF: 0=Through, 1=100 to 20=2000, LPF: 5=500 to 24=2400, 25=Through)
	050013	Send/read SSB TX Tone (Bass) level (0=-5 to 10=+5)
	050014	Send/read SSB TX Tone (Treble) level (0=-5 to 10=+5)
	050015	Send/read AM TX Tone (Bass) level (0=-5 to 10=+5)
	050016	Send/read AM TX Tone (Treble) level (0=-5 to 10=+5)
	050017	Send/read FM TX Tone (Bass) level (0=-5 to 10=+5)
	050018	Send/read FM TX Tone (Treble) level (0=-5 to 10=+5)
	050019	Send/read SSB TX bandwidth for wide (see p. 14-10 for details)
	050020	Send/read SSB TX bandwidth for mid. (see p. 14-10 for details)
	050021	Send/read SSB TX bandwidth for narrow (see p. 14-10 for details)
	050022	Send/read speech level (0=0% to 255=100%)

◇ Command table (continued)

Command	Sub command	Description
1A	050023	Send/read CW side tone gain (0=min. to 255=max.)
	050024	Send/read CW side tone gain limit (0=OFF, 1=ON)
	050025	Send/read beep gain (0=min. to 255=max.)
	050026	Send/read beep gain limit (0=OFF, 1=ON)
	050027	Send/read headphones output ratio (0=0.60 to 255=1.40)
	050028	Send/read AF output level to ACC (0=0% to 255=100%)
	050029	Send/read S/P DIF output level (0=0% to 255=100%)
	050030	Send/read MOD output level to ACC (0=0% to 255=100%)
	050031	Send/read S/P DIF MOD output level (0=0% to 255=100%)
	050032	Send/read MOD input connector during DATA OFF (0=MIC; 1=ACC; 2=MIC/ACC; 3=S/P DIF)
	050033	Send/read MOD input connector during DATA1 (0=MIC; 1=ACC; 2=MIC/ACC; 3=S/P DIF)
	050034	Send/read MOD input connector during DATA2 (0=MIC; 1=ACC; 2=MIC/ACC; 3=S/P DIF)
	050035	Send/read MOD input connector during DATA3 (0=MIC; 1=ACC; 2=MIC/ACC; 3=S/P DIF)
	050036	Send/read relay type selection (0=Lead, 1=MOS-FET)
	050037	Send/read external meter output selection (0=Auto, 1=S, 2=Po, 3=SWR, 4=ALC, 5=COMP, 6=Vd, 7=Id)
	050038	Send/read external meter output level (0=0% to 255=100%)
	050039	Send/read reference signal in/out setting (0=OFF, 1=IN, 2=OUT)
	050040	Send/read reference signal frequency setting (0=0% to 255=100%)
	050041	Send/read LCD unit backlight brightness (0=0% to 255=100%)
	050042	Send/read switch indicator brightness (0=0% to 255=100%)
	050043	Send/read screen image type (0=A, 1=B)
	050044	Send/read frequency readout font (0=Basic (1), 1=Basic (2), 2=Italic, 3=Round, 4=Slim)
	050045	Send/read meter response setting (0=SLOW, 1=MID, 2=FAST)
	050046	Send/read meter type (0=Standard, 1=Edgewise, 2=Bar)
	050047	Send/read meter type during wide screen or mini scope indication (0=Edgewise, 1=Bar)
	050048	Send/read peak hold set for Bar meter (0=OFF, 1=ON)

Command	Sub command	Description
1A	050049	Send/read memory name indication setting (0=OFF, 1=ON)
	050050	Send/read audio peak filter width pop-up indication setting (0=OFF, 1=ON)
	050051	Send/read manual notch width pop-up indication setting (0=OFF, 1=ON)
	050052	Send/read screen saver set (0=OFF, 1=15 min., 2=30 min., 3=60 min.)
	050053	Set/read screen saver type (0=Bound, 1=Rotation, 2=Twist)
	050054	Send/read output signal setting for external display (0=OFF, 1=ON)
	050055	Send/read synchronous pulse level setting (0=L, 1=H)
	050056	Send/read opening message indication (0=OFF, 1=ON)
	050057	Send/read opening message contents (see p. 14-9 for details)
	050058	Send/read date (20000101=1st Jan. 2000 to 20991231=31st Dec. 2099)
	050059	Send/read time (0000=00:00 to 2359=23:59)
	050060	Send/read CLOCK2 function (0=OFF, 1=ON)
	050061	Send/read offset time for CLOCK2 (240001=-24:00 to 240000=+24:00)
	050062	Send/read CLOCK2 name (up to 3-character; see p. 14-9)
	050063	Send/read calibration marker (0=OFF, 1=ON)
	050064	Send/read confirmation beep (0=OFF, 1=ON)
	050065	Send/read band edge beep (0=OFF, 1=ON)
	050066	Send/read beep audio frequency (50=500 Hz to 200=2000 Hz)
	050067	Send/read quick split set (0=OFF, 1=ON)
	050068	Send/read FM split offset -9.999 to +9.999 MHz for HF (see p. 14-10 for details)
	050069	Send/read FM split offset -9.999 to +9.999 MHz for 50 MHz (see p. 14-10 for details)
	050070	Send/read split lock set (0=OFF, 1=ON)
	050071	Send/read tuner auto start set (0=OFF, 1=ON)
	050072	Send/read PTT tune set (0=OFF, 1=ON)
	050073	Send/read transverter set (0=OFF, 1=ON)
	050074	Send/read transverter offset (see p. 14-10 for details)
	050075	Send/read RTTY mark frequency (0=1275 Hz, 1=1615 Hz, 2=2125 Hz)
	050076	Send/read RTTY shift width (0=170 Hz, 1=200 Hz, 2=425 Hz)

◇ Command table (continued)

Command	Sub command	Description
1A	050077	Send/read RTTY keying polarity (0=Normal, 1=Reverse)
	050078	Send/read PSK tone frequency (0=1000 Hz, 1=1500 Hz, 2=2000 Hz)
	050079	Send/read speech language (0=English, 1=Japanese)
	050080	Send/read speech speed (0=Slow, 1=Fast)
	050081	Send/read S-level speech (0=OFF, 1=ON)
	050082	Send/read speech with a mode switch operation (0=OFF, 1=ON)
	050083	Send/read memo pad numbers (0=5 ch, 1=10 ch)
	050084	Send/read main dial auto TS (0=OFF, 1=Low, 2=High)
	050085	Send/read mic. up/down speed (0=Low, 1=High)
	050086	Send/read quick RIT/ Δ TX clear function (0=OFF, 1=ON)
	050087	Send/read SSB notch operation (0=Auto, 1=Manual, 2=Auto/Manual)
	050088	Send/read AM notch operation (0=Auto, 1=Manual, 2=Auto/Manual)
	050089	Send/read DIGI-SEL control function (0=DIGI-SEL, 1=APF)
	050090	Send/read SSB/CW synchronous tuning function (0=OFF, 1=ON)
	050091	Send/read CW normal side set (0=LSB, 1=USB)
	050192	Set/read APF type (0=SHARP, 1=SOFT)
	050093	Send/read external keypad set for voice memory (0=OFF, 1=ON)
	050094	Send/read external keypad set for keyer memory (0=OFF, 1=ON)
	050095	Send/read CI-V transceive set (0=OFF, 1=ON)
	050096	Send/read RS-232C function (0=CI-V, 1=Decode)
	050097	Send/read RS-232C decode Baud rate (0=300, 1=1200, 2=4800, 3=9600, 4=19200)
	050098	Send/read keyboard type (00=English, 01=Japanese, 02=United Kingdom, 03=French, 04=French (Canadian), 05=German, 06=Portuguese, 07=Portuguese (Brazilian), 08=Spanish, 09=Spanish (Latin American), 10=Italian)
	050099	Send/read keyboard repeat delay (10=100 msec. to 100=1000 msec.)
	050100	Send/read keyboard repeat rate (0=2.0 cps to 31=30.0 cps)
	050101	Send/read IP address set (0000000000000001=0.0.0.1 to 0255025502550254=255.255.255.254)

Command	Sub command	Description
1A	050102	Send/read subnet mask (1=128.0.0.0 to 30=255.255.255.252)
	050103	Send/read scope indication during TX (0=OFF, 1=ON)
	050104	Send/read scope max. hold (0=OFF, 1=ON)
	050105	Send/read scope center frequency set (0=Filter center, 1=Carrier point center, 2=Carrier point center (Abs. Freq.))
	050106	Send/read waveform color for receiving signal (see p. 14-10 for details)
	050107	Send/read waveform color for max. hold (see p. 14-10 for details)
	050108	Send/read scope sweep speed for ± 2.5 kHz span (0=Slow, 1=Mid., 2=Fast)
	050109	Send/read scope sweep speed for ± 5 kHz span (0=Slow, 1=Mid., 2=Fast)
	050110	Send/read scope sweep speed for ± 10 kHz span (0=Slow, 1=Mid., 2=Fast)
	050111	Send/read scope sweep speed for ± 25 kHz span (0=Slow, 1=Mid., 2=Fast)
	050112	Send/read scope sweep speed for ± 50 kHz span (0=Slow, 1=Mid., 2=Fast)
	050113	Send/read scope sweep speed for ± 100 kHz span (0=Slow, 1=Mid., 2=Fast)
	050114	Send/read scope sweep speed for ± 250 kHz span (0=Slow, 1=Mid., 2=Fast)
	050115	Send/read scope edge frequencies for 0.03 to 1.60 MHz band (see p. 14-10 for details)
050116	Send/read scope edge frequencies for 1.60 to 2.00 MHz band (see p. 14-10 for details)	
050117	Send/read scope edge frequencies for 2.00 to 6.00 MHz band (see p. 14-10 for details)	
050118	Send/read scope edge frequencies for 6.00 to 8.00 MHz band (see p. 14-10 for details)	
050119	Send/read scope edge frequencies for 8.00 to 11.00 MHz band (see p. 14-10 for details)	
050120	Send/read scope edge frequencies for 11.00 to 15.00 MHz band (see p. 14-10 for details)	
050121	Send/read scope edge frequencies for 15.00 to 20.00 MHz band (see p. 14-10 for details)	
050122	Send/read scope edge frequencies for 20.00 to 22.00 MHz band (see p. 14-10 for details)	
050123	Send/read scope edge frequencies for 22.00 to 26.00 MHz band (see p. 14-10 for details)	

◇ Command table (continued)

Command	Sub command	Description
1A	050124	Send/read scope edge frequencies for 26.00 to 30.00 MHz band (see p. 14-10 for details)
	050125	Send/read scope edge frequencies for 30.00 to 45.00 MHz band (see p. 14-10 for details)
	050126	Send/read scope edge frequencies for 45.00 to 60.00 MHz band (see p. 14-10 for details)
	050127	Send/read auto voice monitor set (0=OFF, 1=ON)
	050128	Send/read voice memory short play time (3=3 sec. to 10=10 sec.)
	050129	Send/read voice memory normal record time (5= 5 sec. to 15=15 sec.)
	050130	Send/read contest number style (0=Normal, 1=190→ANO, 2=190→ANT, 3=90→NO, 4=90→NT)
	050131	Send/read count up trigger channel (1=M1, 2=M2, 3=M3, 4=M4)
	050132	Send/read present number (1-9999)
	050133	Send/read CW keyer repeat time (1=1 sec. to 60=60 sec.)
	050134	Send/read CW keyer dot/dash ratio (28=1:1:2.8 to 45=1:1:4.5)
	050135	Send/read rise time (0=2 msec., 1=4 msec., 2=6 msec., 3=8 msec.)
	050136	Send/read paddle polarity (0=Normal, 1=Reverse)
	050137	Send/read keyer type (0=Straight, 1=Bug-key, 2=ELEC-Key)
	050138	Send/read mic. up/down keyer set (0=OFF, 1=ON)
	050139	Send/read FFT scope averaging set for RTTY decoder (0=OFF, 1=2, 2=3, 3=4)
	050140	Send/read FFT scope waveform color set for RTTY decoder (see p. 14-10 for details)
	050141	Send/read RTTY decode USOS (0=OFF, 1=ON)
	050142	Send/read RTTY decode new line code (0=CR,LF,CR+LF, 1=CR+LF)
	050143	Send/read RTTY diddle (0=OFF, 1=Blank, 2=LTRS (Letter code))
	050144	Send/read RTTY TX USOS (0=OFF, 1=ON)
	050145	Send/read RTTY auto CR+LF by TX (0=OFF, 1=ON)
	050146	Send/read RTTY time stamp set (0=OFF, 1=ON)
	050147	Send/read clock selection for time stamp (0=Local time, 1=CLOCK2)
	050148	Send/read frequency stamp (0=OFF, 1=ON)
	050149	Send/read received text font color (see p. 14-10 for details)
	050150	Send/read transmitted text font color (see p. 14-10 for details)

Command	Sub command	Description
1A	050151	Send/read time stamp text font color (see p. 14-10 for details)
	050152	Send/read text font color in TX buffer (see p. 14-10 for details)
	050153	Send/read FFT scope averaging set for PSK decoder (0=OFF, 1=2, 2=3, 3=4)
	050154	Send/read FFT scope waveform color set for PSK decoder (see p. 14-10 for details)
	050155	Send/read PSK AFC function tuning range (0=±8 Hz, 1=±15 Hz)
	050156	Send/read PSK time stamp set (0=OFF, 1=ON)
	050157	Send/read clock selection for time stamp (0=Local time, 1=CLOCK2)
	050158	Send/read frequency stamp (0=OFF, 1=ON)
	050159	Send/read received text font color (see p. 14-10 for details)
	050160	Send/read transmitted text font color (see p. 14-10 for details)
	050161	Send/read time stamp text font color (see p. 14-10 for details)
	050162	Send/read text font color in TX buffer (see p. 14-10 for details)
	050163	Send/read scan speed (0=Low, 1=High)
	050164	Send/read scan resume (0=OFF, 1=ON)
	050165	Send/read antenna selection for 0.03 to 1.60 MHz band (see p. 14-10 for details)
	050166	Send/read antenna selection for 1.60 to 2.00 MHz band (see p. 14-10 for details)
	050167	Send/read antenna selection for 2.00 to 6.00 MHz band (see p. 14-10 for details)
050168	Send/read antenna selection for 6.00 to 8.00 MHz band (see p. 14-10 for details)	
050169	Send/read antenna selection for 8.00 to 11.00 MHz band (see p. 14-10 for details)	
050170	Send/read antenna selection for 11.00 to 15.00 MHz band (see p. 14-10 for details)	
050171	Send/read antenna selection for 15.00 to 20.00 MHz band (see p. 14-10 for details)	
050172	Send/read antenna selection for 20.00 to 22.00 MHz band (see p. 14-10 for details)	
050173	Send/read antenna selection for 22.00 to 26.00 MHz band (see p. 14-10 for details)	
050174	Send/read antenna selection for 26.00 to 30.00 MHz band (see p. 14-10 for details)	
050175	Send/read antenna selection for 30.00 to 45.00 MHz band (see p. 14-10 for details)	

14 CONTROL COMMAND

◇ Command table (continued)

Command	Sub command	Description
1A	050176	Send/read antenna selection for 45.00 to 60.00 MHz band (see p. 14-10 for details)
	050177	Send/read antenna temporary memory set (0=OFF, 1=ON)
	050178	Send/read antenna selection (0=OFF, 1=Manual, 2=Auto)
	050179	Send/read usage for ANT2 (0=OFF, 1=TX/RX)
	050180	Send/read usage for ANT3 (0=OFF, 1=TX/RX)
	050181	Send/read usage for ANT4 (0=OFF, 1=TX/RX, 2= RX)
	050182	Send/read VOX delay (0=0.0 sec. to 20=2.0 sec.)
	050183	Send/read VOX voice delay (0=OFF, 1=Short, 2=Mid., 3=Long)
	050184	Send/read NB depth (0=1 to 9=10)
	050185	Send/read NB width (0=0 to 255=255)
	06	Send/read DATA mode with filter set (see p. 14-10 for detail)
	07	Send/read SSB transmit bandwidth (0=WIDE, 1=MID, 2=NAR)
	08	Send/read DSP filter shape (0= Sharp, 1= Soft)
09	Send/read roofing filter set (0=3 kHz, 1=6 kHz, 2=15 kHz)	
0A	Send/read manual notch width (0=Wide, 1=Mid., 2=Nar.)	
1B	00	Send/read repeater tone frequency (see p. 14-10 for details)
	01	Set/read TSQL tone frequency (see p. 14-10 for details)
1C	00	Send/read the transceiver's condition (0=Rx; 1=Tx)
	01	Send/read antenna tuner condition (0=OFF, 1=ON, 2=Start tuning or while tuning)

◇ To send/read memory contents

When sending or reading memory contents, additional codes must be added to append the memory channel as follows.

➔ Additional code: 0000–0101 (0100=P1, 0101=P2)

◇ Band stacking register

To send or read the desired band stacking register's contents, combined codes of the frequency band and register codes as follows are used.

For example, when sending/reading the oldest contents in the 21 MHz band, the code "0703" is used.

• Frequency band code

Code	Frequency band	Frequency range (unit: MHz)
01	1.8	1.800000– 1.999999
02	3.5	3.400000– 4.099999
03	7	6.900000– 7.499999
04	10	9.900000–10.499999
05	14	13.900000–14.499999
06	18	17.900000–18.499999
07	21	20.900000–21.499999
08	24	24.400000–25.099999
09	28	28.000000–29.999999
10	50	50.000000–54.000000
12	GENE	Other than above

• Register code

Code	Registered number
01	1 (latest)
02	2
03	3 (oldest)

◇ Codes for memory keyer contents

To send or read the desired memory keyer contents, the channel and character codes as follows are used.

• Channel code

Code	Channel number
01	M1
02	M2
03	M3
04	M4

• Character's code

Character	ASCII code	Description
0–9	30–39	Numerals
A–Z	41–5A	Alphabetical characters
space	20	Word space
/	2F	Symbol
?	3F	Symbol
,	2C	Symbol
.	2E	Symbol
^	5E	e.g., to send \bar{B} , enter ^4254
*	2A	Inserts contest number (can be used for 1 channel only)

◇ Codes for memory name, opening message and CLOCK2 name contents

To send or read the desired memory name settings, the character codes, instructed codes for memory keyer contents as above, and follows are used.

• Character's code— Alphabetical characters

Character	ASCII code	Character	ASCII code
a–z	61–7A	—	—

• Character's code— Symbols

Character	ASCII code	Character	ASCII code
!	21	#	23
\$	24	%	25
&	26	¥	5C
?	3F	"	22
'	27	`	60
+	2B	–	2D
:	3A	;	3B
=	3D	<	3C
>	3E	(28
)	29	[5B
]	5D	{	7B
}	7D		7C
_	5F	–	7E
@	40		

◆ Offset frequency setting

The following data sequence is used when sending or reading the offset frequency setting.

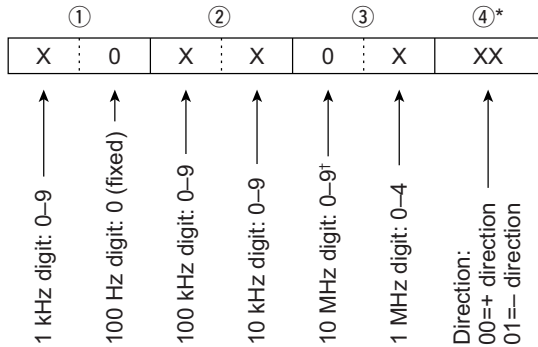

*No need to enter for transverter offset frequency setting.
[†]Transverter offset only; Fix to '0' for split offset setting.

◆ Repeater tone/tone squelch frequency setting

The following data sequence is used when sending or reading the tone frequency setting.

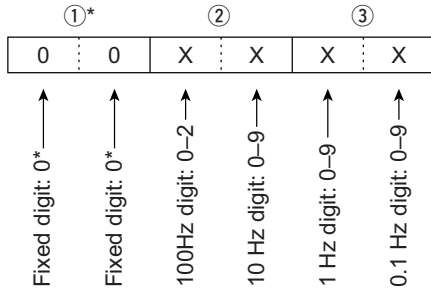

*Not necessary when setting a frequency.

◆ SSB transmission passband width setting

The following data sequence is used when sending or reading the SSB transmission passband width setting.

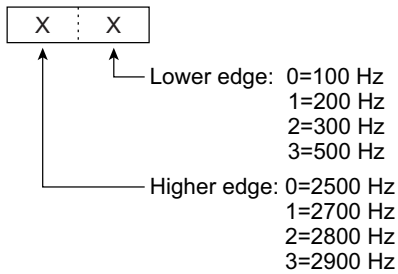

◆ Color setting

The following data sequence is used when sending or reading the color setting.

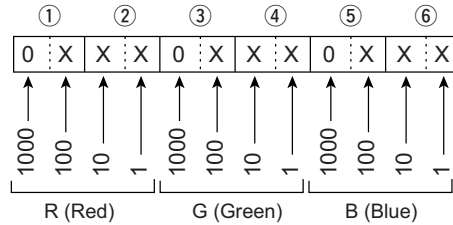

Using 0000-0255 for each color element.

◆ Bandscope edge frequency setting

The following data sequence is used when sending or reading the bandscope edge frequency setting.

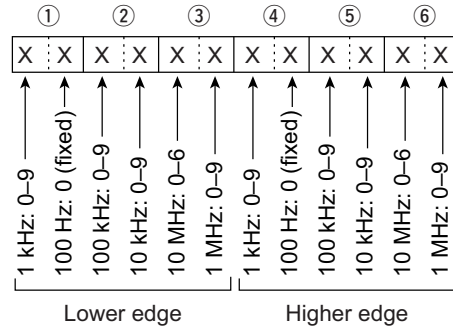

◆ Data mode with filter width setting

The following data sequence is used when sending or reading the data mode with filter width setting.

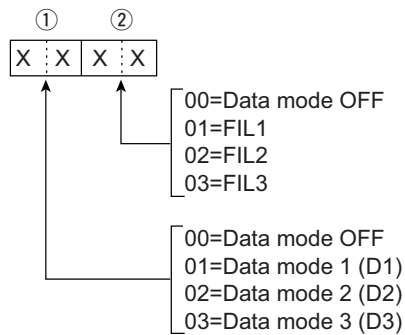

◆ Antenna memory setting

The following codes are used when sending or reading the antenna memory setting.

- 0=ANT1, 1=ANT2, 2=ANT3, 3=ANT4,
- 4*=TX: ANT1, RX: ANT4, 5*=TX: ANT2, RX: ANT4,
- 6*=TX: ANT3, RX: ANT4

*RX should be selected for ANT4

- Specifications 15-2
 - ◇ General 15-2
 - ◇ Transmitter 15-2
 - ◇ Receiver 15-3
 - ◇ Antenna tuner 15-3
- Options 15-4

■ Specifications

◇ General

- **Frequency coverage** (unit: MHz) :
 - Receiver : 0.030000–60.000000*¹
 - Transmitter : 1.800000–1.999999*², 3.500000–3.999999*²,
5.330500*³, 5.346500*³, 5.366500*³, 5.371500*³,
5.403500*³, 7.000000–7.300000*²,
10.100000–10.150000*², 14.000000–14.350000*²,
18.068000–18.168000*², 21.000000–21.450000*²,
24.890000–24.990000*², 28.000000–29.700000*²,
50.000000–54.000000*²
- **Operating mode** : USB, LSB, CW, RTTY, PSK31, AM, FM
- **Number of memory channels** : 101 (99 regular, 2 scan edges)
- **Antenna connector** : SO-239×4 (antenna impedance: 50 Ω)
- **Operating temperature range** : 0°C to +50°C; +32°F to +122°F
- **Frequency stability** : Less than ±0.05 ppm (approx. 5 min. after from turn
the main power, [I/O], ON, 0–50°C; 32–122°F)
- **Frequency resolution** : 1 Hz
- **Power supply requirement** : 85–265 V AC (universal input)
- **Power consumption** :
 - Receive : 200 VA typical
 - Stand-by : 210 VA typical
 - Max. audio : 800 VA
 - Transmit at 200 W
- **Dimensions** (projections not included) : 425×149×437 mm; 16²³/₃₂×5⁷/₈×17⁷/₃₂ in
- **Weight** : Approx. 22.5 kg; 50 lb
- **ACC 1 connectors** : 8-pin DIN connector
- **ACC 2 connectors** : 7-pin DIN connector
- **Display*** : 7-inch (diagonal) TFT color LCD (800×480)
- **EXT-DISPLAY connector** : D-sub 15S
- **CI-V connector** : 2-conductor 3.5 (d) mm (1/8")
- **RS-232C connector** : D-sub 9-pin
- **USB connector** : USB (Universal Serial Bus)1.1/2.0×2

*¹Some frequency ranges are not guaranteed.
*²Depending on versions. *³USA version only.

◇ Transmitter

- **Transmit output power** :
 - SSB, CW, RTTY, PSK31, FM : 5–200 W
 - AM : 5–50 W
- **Modulation system** :
 - SSB : P.S.N. modulation
 - AM : Low power modulation
 - FM : Phase modulation
- **Spurious emission** :
 - More than 60 dB (HF bands)
 - More than 70 dB (50 MHz band)
- **Carrier suppression** : More than 63 dB
- **Unwanted side-band suppression** : More than 80 dB
- **ΔTX variable range** : ±9.999 kHz
- **Microphone connector** : 8-pin connector (600 Ω)
- **ELEC-KEY connector** : 3-conductor 6.35 (d) mm (1/4")
- **KEY connector** : 3-conductor 6.35 (d) mm (1/4")
- **RELAY connector** : Phono (RCA)
- **ALC connector** : Phono (RCA)

◇ Receiver

- **Receive system** : Double conversion superheterodyne system
- **Intermediate frequencies** :
 - 1st 64.455 MHz
 - 2nd 36 kHz
- **Sensitivity** (typical) :
 - SSB, CW, RTTY (BW=2.4 kHz, 10 dB S/N)
 - 0.100000– 1.799999 MHz 0.5 μ V (pre-amp 1 ON)
 - 1.800000–29.990000 MHz 0.16 μ V (pre-amp 1 ON)
 - 50.000000–54.000000 MHz 0.13 μ V (pre-amp 2 ON)
 - AM (BW=6 kHz, 10 dB S/N)
 - 0.100000– 1.799999 MHz 6.3 μ V (pre-amp 1 ON)
 - 1.800000–29.990000 MHz 2 μ V (pre-amp 1 ON)
 - 50.000000–54.000000 MHz 1 μ V (pre-amp 2 ON)
 - FM (BW=15 kHz, 12 dB SINAD)
 - 28.000000–29.990000 MHz 0.5 μ V (pre-amp 1 ON)
 - 50.000000–54.000000 MHz 0.32 μ V (pre-amp 2 ON)
- **Internal Modulate Distortion** (typical) : Dynamic range 105 dB
(at 14.100 MHz, 100 kHz separation, pre-amp OFF, CW mode; BW=500 Hz)
- **Selectivity** :
 - SSB, RTTY (BW=2.4 kHz)
 - More than 2.4 kHz/–3 dB
 - Less than 3.6 kHz/–60 dB
 - CW (BW=500 Hz)
 - More than 500 Hz/–3 dB
 - Less than 700 Hz/–60 dB
 - AM (BW=6 kHz)
 - More than 6.0 kHz/–3 dB
 - Less than 15.0 kHz/–60 dB
 - FM (BW=15 kHz)
 - More than 12.0 kHz/–6 dB
 - Less than 20.0 kHz/–60 dB
- **Spurious and image rejection ratio** : More than 70 dB (except IF through on 50 MHz band)
- **Squelch sensitivity** (pre-amp OFF) :
 - SSB, CW, RTTY, PSK31 Less than 5.6 μ V
 - FM Less than 1 μ V
- **RIT variable range** : \pm 9.999 kHz
- **Audio output power** : More than 2.6 W at 10% distortion with an 8 Ω load
- **PHONES connector** : 3-conductor 6.35 (d) mm ($\frac{1}{4}$ ")
- **EXT-SP connectors** : 2-conductor 3.5 (d) mm ($\frac{1}{8}$ ")/8 Ω

◇ Antenna tuner

- **Matching impedance range** : 16.7 to 150 Ω unbalanced
(HF bands; VSWR better than 3:1)
20 to 125 Ω unbalanced
(50 MHz band; VSWR better than 2.5:1)
- **Minimum operating input** : 8 W (HF bands)
15 W (50 MHz band)
- **Tuning accuracy** : VSWR 1.5:1 or less
- **Insertion loss** (after tuning) : Less than 1.0 dB

*The LCD display may have cosmetic imperfections that appear as small or dark spots. This is not a malfunction or defect, but a normal characteristic of LCD displays.

Spurious signals may be received near the following frequencies. These are made in the internal circuit and does not indicate a transceiver malfunction.

- 0.15 MHz • 0.23 MHz 0.31 MHz • 10 MHz

Spurious waveforms may be displayed on the spectrum scope screen regardless of the transceiver's condition (Tx or Rx). They are made in the scope circuit. This does not indicate a transceiver malfunction.

All stated specifications are typical and subject to change without notice or obligation.

Options

- **IC-PW1/EURO** HF/50 MHz ALL BAND 1 kW LINEAR AMPLIFIER



Full-duty-cycle 1 kW linear amplifier including an automatic antenna tuner. Has automatic tuning and band selection capability when used with an Icom transceiver. Full break-in (QSK) operation. The amplifier/power supply unit and the remote control unit are separate.

- **SM-20** DESKTOP MICROPHONE



Unidirectional, electret microphone for base station operation. Includes [UP]/[DOWN] switches and a low cut function.

- **CT-17** CI-V LEVEL CONVERTER



For remote transceiver control using a PC. You can change frequencies, operating mode, memory channels, etc. (software is not included)

- **SP-20** EXTERNAL SPEAKER



4 audio filters; headphone jack; can connect to 2 transceivers.

- Input impedance : 8 Ω
- Max. input power : 5 W

- **HM-36** HAND MICROPHONE



Hand microphone equipped with [UP]/[DOWN] switches.

- General 16-2
- Caution 16-2
- Preparation 16-3
 - ◇ Firmware and firm utility 16-3
 - ◇ File downloading 16-3
- Firmware update— USB-Memory 16-4
- Firmware update— PC 16-6
 - ◇ Connections 16-6
 - ◇ IP address setting 16-7
 - ◇ Updating from the PC 16-8

■ General

At least one available USB (2.0 or 1.1) port is required to copy the downloaded firmware file. An Ethernet card/board (10 BASE-T/100 BASE TX compatible) is required when updating the firmware from the PC. The USB hub and Ethernet card/board are not supplied by Icom. Ask your PC dealer about a USB hub and an Ethernet card/board for details.

The IC-7700's firmware can be updated if desired. By updating the firmware, new function(s) can be added and the improvement of performance parameters can be made.

2 methods of firmware update are available: one uses the USB-Memory, and the other uses a PC. You can choose either methods according to your PC capabilities.

- When only one PC connected to the Internet is available
 - ➔ Refer to ■ Preparation (p. 16-3) and ■ Firmware update— USB-Memory (p. 16-4)
- When two or more PCs connected to the Internet are available and they are connected to a LAN (Local Area Network)
 - ➔ Refer to ■ Preparation (p. 16-3) and either
 - Firmware update— PC (p. 16-6) or
 - Firmware update— USB-Memory (p. 16-4)

Ask your dealer or distributor about how to update the firmware if you have no PC.

■ Caution

⚠ **CAUTION!:** NEVER turn the transceiver power OFF while updating the firmware.

You can turn the transceiver power OFF only when the transceiver displays that rebooting is required.

If you turn the transceiver power OFF, or if a power failure occurs during updating, the transceiver firmware will be corrupted and you will have to send the transceiver back to the nearest Icom distributor for repair. This type of repair is out of warranty even if the warranty period is still valid.

Recommendation!

Backing up the settings and/or memory contents to the USB-Memory before starting the firmware update is recommended.

Settings and/or memory contents will be lost or returned to default settings when the firmware update is performed.

■ Preparation

◇ Firmware and firm utility

The latest firmware and the firm utility can be downloaded from the Icom home page via the Internet. Access the following URL to download the firm utility and the latest firmware.

<http://www.icom.co.jp/world/support/index.htm>

For updating from the USB-Memory

When updating the firmware from the USB-Memory, copy the downloaded firmware data (e.g. 7700_110.dat) to the USB-Memory (in "IC-7700" folder) using an available USB port (USB hub may be required; purchased separately from your PC dealer).

◇ File downloading

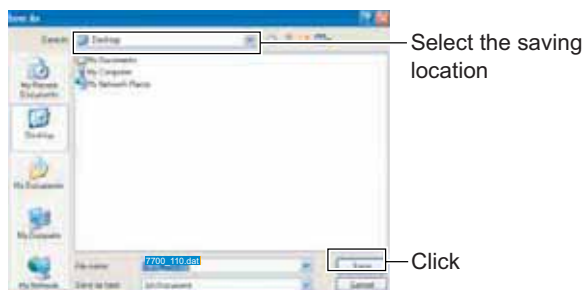
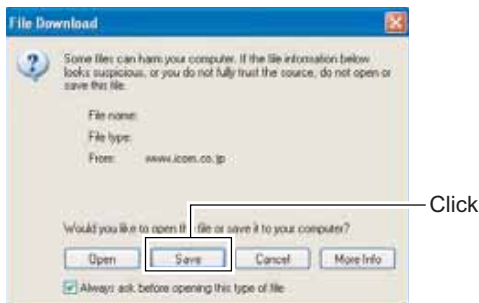
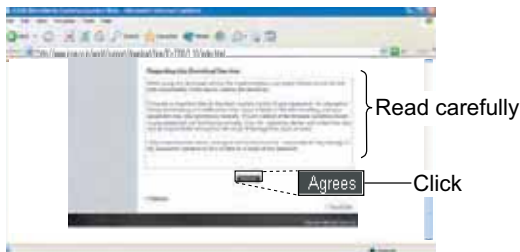

- ① Access the following URL directly.
<http://www.icom.co.jp/world/support/index.htm>
- ② Click "Firmware Updates/Software Downloads" link then click the firmware file link.

- ③ Read "Regarding this Download Service" carefully, then click [AGREE].

- ④ Click [Save] in the displayed File Download dialog.

- ⑤ Select the desired location in which you want to save the firmware, then click [Save] in the displayed File Download dialog.
 - File download starts.

- ⑥ After download is completed, extract the file.
 - The firmware and the firm utility are compressed in "zip" format, respectively.
 - When updating the transceiver using with the USB-Memory, copy the extracted firmware (e.g. 7700_110.dat) to the USB-Memory IC-7700 folder.
 - The USB-Memory must have been formatted by the IC-7700. (p. 12-26)

Firmware update— USB-Memory

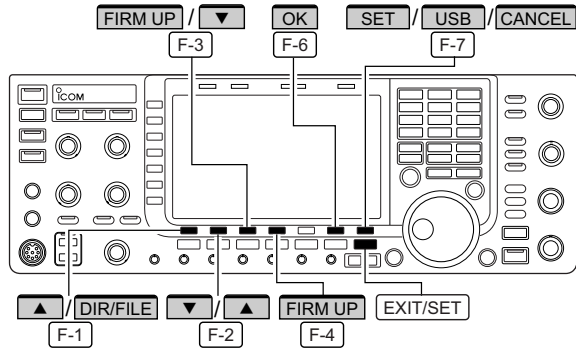

When updating the firmware with the USB-Memory, no IP address or subnet mask settings are necessary.

- ① Copy the downloaded firmware data into the USB-Memory (“IC-7700” folder).
 - The USB-Memory must have been formatted by the IC-7700.
- ② Insert the USB-Memory into the USB connector.
- ③ Push **EXIT/SET** several times to close a multi-function screen, if necessary.
- ④ Push **[SET] F-7** to select set mode menu screen.
- ⑤ Push **[USB] F-7** to select USB-Memory set menu.



- ⑥ Push and hold **[FIRM UP] F-3** for 1 sec.

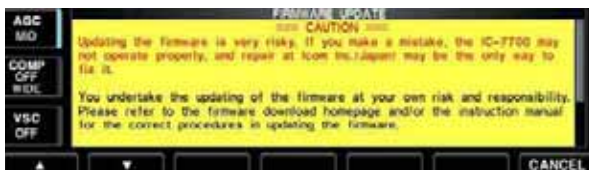

- ⑦ Read the displayed precaution carefully.
 - Push **[▲] F-1** or **[▼] F-2** to scroll the indication.
 - Push **[CANCEL] F-7** to cancel the firmware updating.

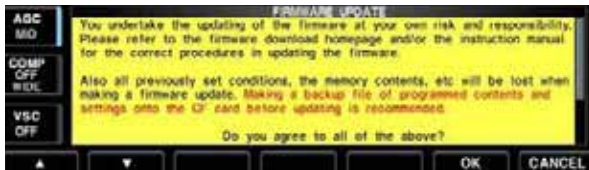

- ⑧ After you read and understand all of the precautions, push **[OK] F-6**.
 - **[OK] F-6** appears only following the precautions.
 - Push **[CANCEL] F-7** to cancel the firmware updating.



- ⑨ Push **[▲] F-2** or **[▼] F-3** to select the firmware file, then push **[FIRM UP] F-4**.

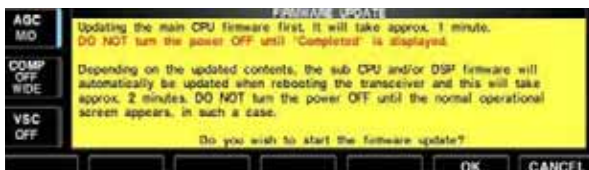

- ⑩ Read the displayed precautions carefully.
- ⑪ If you agree, push and hold **[OK] F-6** for 1 sec. to start the firmware update.
 - Push **[CANCEL] F-7** to cancel the firmware updating.

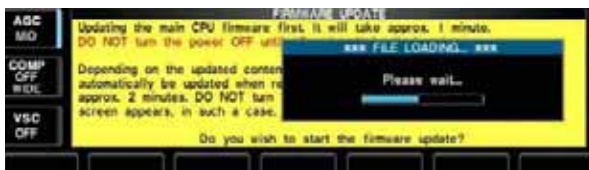

- ⑫ While loading the firmware from the USB-Memory, the dialog as at left is displayed.

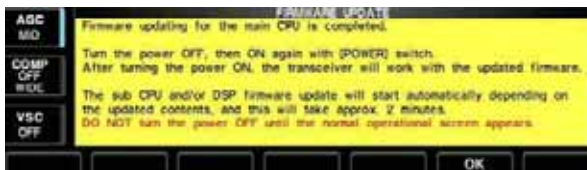

⑬ After the firmware loading is completed, the transceiver starts the update automatically and the dialog at left is displayed.

- ⚠ **WARNING!** NEVER turn the IC-7700 power OFF at this stage.
- ⚠ The transceiver firmware will be corrupted.

⑭ When the dialog disappears, the precaution at left is displayed.

⑮ Read the precaution carefully, and then push [OK] **F-6**.

- Return to USB-Memory set menu.

⑯ Push **POWER** to turn the IC-7700 power OFF, then ON again.

⑰ Depending on the update, one or two dialog boxes as at left appear in sequence.

- ⚠ **WARNING!** NEVER turn the IC-7700 power OFF at this stage.
- ⚠ The transceiver firmware will be corrupted.

⑱ After the dialog disappears, the firmware updating is completed and normal operation screen appears.

■ Firmware update— PC

◇ Connections

Connect the IC-7700 and the PC through a LAN (Local Area Network) as follows.

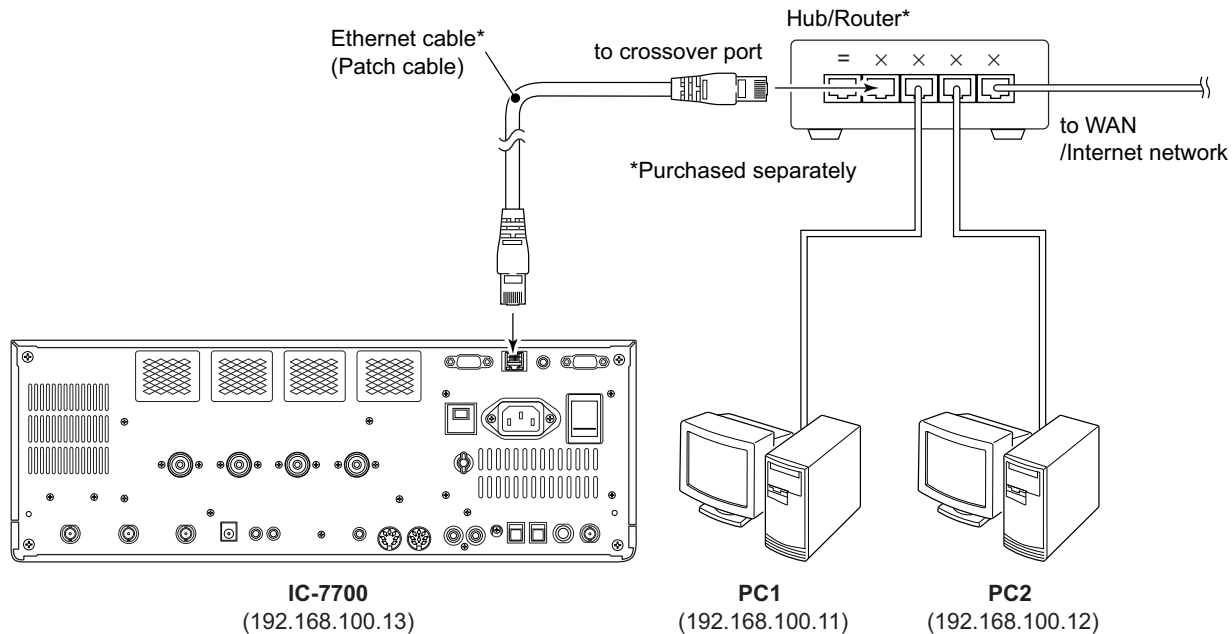

• IP address setting example

	PC1	PC2	IC-7700
IP address	192.168.100.11	192.168.100.12	192.168.100.13
Subnet mask	255.255.255.0	255.255.255.0	255.255.255.0

◇ IP address setting

When updating the firmware from the USB-Memory, the following settings are not necessary.

IMPORTANT!: A fixed (static) IP address is used for the IC-7700.
 When you connect the IC-7700 to a LAN, ask the network manager about a usable/assignable IP address and the subnet mask in advance.
NEVER use an IP address that has already been used with another device in the network. If the IP address is duplicated, the network will crash.

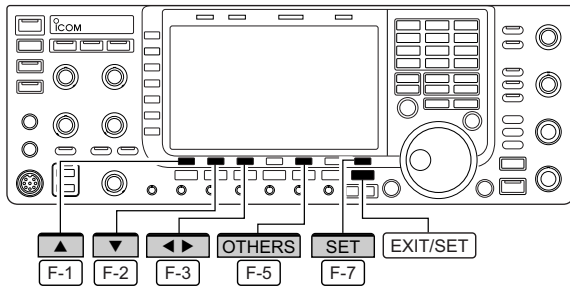

- ① Push [EXIT/SET] several times to close a multi-function screen, if necessary.
- ② Push [SET] [F-7] to select set mode menu screen.
- ③ Push [OTHERS] [F-5] to select Others set mode.
- ④ Push [▲] [F-1] or [▼] [F-2] several times to select "IP Address" item.
- ⑤ Push [◀▶] [F-3] to select the desired part then rotate the main dial to set the desired or specified IP address.
 - "192.168.0.1" is the default setting.
- ⑥ Push [▼] [F-2] to select "Subnet Mask" item.
- ⑦ Rotate the main dial to set the desired or specified subnet mask.
 - "255.255.255.0" is the default setting.
- ⑧ Push [POWER] to turn the transceiver power OFF, then ON to enable the IP address and subnet mask settings.

◆ Updating from the PC



- ① Start up the IC-7700 Firm Utility.
 - The window as at left appears.
- ② Read the caution in the window carefully.
- ③ Click [Yes] if you agree and continue the firmware updating.

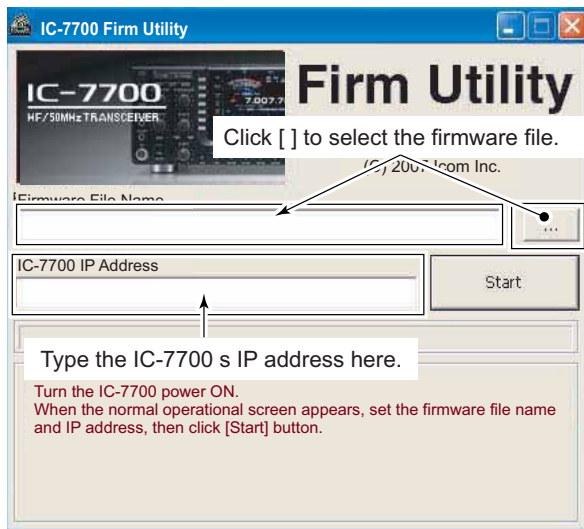

- ④ Select the firmware file, that has “dat” extension (e.g.: 7700_110.dat).
 - Click [...], then select the file, as well as the location.
- ⑤ Type the IC-7700’s IP address into “IC-7700 IP Address” text box.
- ⑥ Click [Start].

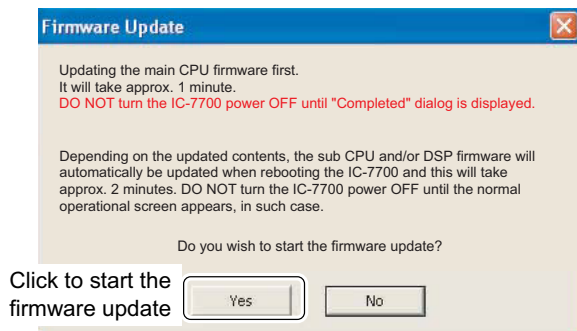

- ⑦ The window as at left appears.
 - Read the precaution in the window carefully.
- ⑧ Click [Yes] if you want to start the firmware update.

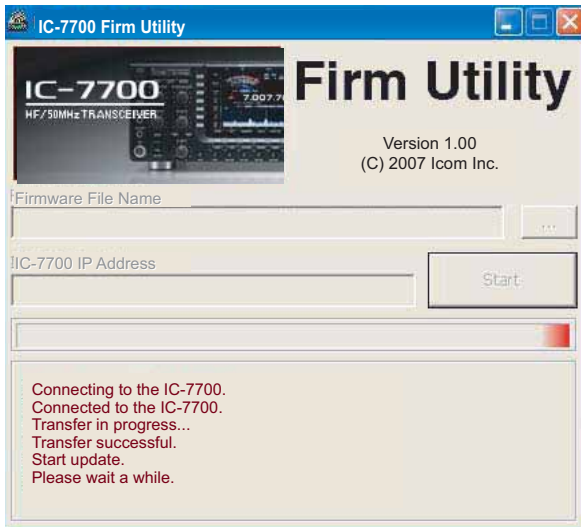

- ⑨ The screen as at left is displayed.
 - The following dialog appears in the IC-7700 display.



- ⚠ **WARNING!** NEVER turn the IC-7700 power OFF at this stage. The transceiver firmware will be corrupted.

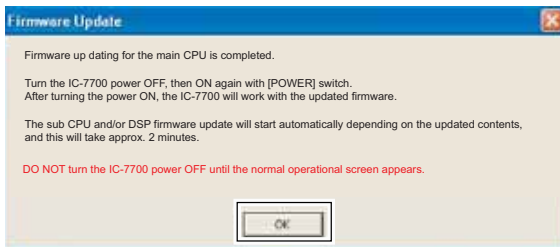

Click [OK] to finish the firmware update.



- ⑩ Click [OK] to finish the firmware update.
 - The “FIRMWARE UPDATING” dialog as above disappears.
- ⑪ Push **[POWER]** to turn the IC-7700 power OFF, then ON again.

- ⑫ Depending on the update, one or two dialog boxes as at left appear on the IC-7700 display in sequence.

- ⚠ **WARNING!** NEVER turn the IC-7700 power OFF at this stage. The transceiver firmware will be corrupted.

- ⑬ After the dialog disappears, the firmware update is completed and normal operation screen appears.

INSTALLATION NOTES

For amateur base station installations it is recommended that the clearance in front of the antenna array is calculated relative to the EIRP (Effective Isotropic Radiated Power). The clearance height below the antenna array can be determined in most cases from the RF power at the antenna input terminals.

Different exposure limits have been recommended for different frequencies, a relative table shows a guideline for installation considerations.

Below 30 MHz, the recommended limits are specified in terms of V/m or A/m fields as they are likely to fall within the near-field region. Similarly, the antennas may be physically short in terms of electrical length and that the installation will require some antenna matching device which can create local, high intensity magnetic fields. Analysis of such installations is best considered in association with published guidance notes such as the FCC OET Bulletin 65 Edition 97-01 and its annexes relative to amateur transmitter installations. The EC recommended limits are almost identical to the FCC specified 'uncontrolled' limits and tables exist that show pre-calculated safe distances for different antenna types for different frequency bands. Further information can be found at <http://www.arrl.org/>.

• Typical amateur radio installation

Exposure distance assumes that the predominant radiation pattern is forward and that radiation downward is at unity gain (side lobe suppression is equal to main lobe gain). This is true of almost every gain antenna today. Exposed persons are assumed to be beneath the antenna array and have a typical height of 1.8 m.

The figures assume the worst-case emission of constant carrier.

For the bands 10 MHz and higher the following power density limits have been recommended:

10–144 MHz 2 W/sq m

EIRP clearance heights by frequency band

1 Watts 2.1 m
 10 Watts 2.8 m
 25 Watts 3.4 m
 100 Watts 5 m
 1000 Watts 12 m

Forward clearance, EIRP by frequency band

100 Watts 2 m
 1000 Watts 6.5 m
 10,000 Watts 20 m
 100,000 Watts 65 m

In all cases any possible risk depends on the transmitter being activated for long periods. (actual recommendation limits are specified as an average during 6 minutes) Normally the transmitter is not active for long periods of time. Some radio licenses will require that a timer circuit automatically cuts the transmitter after 1–2 minutes etc.

Similarly some types of emission, i.e., SSB, CW, AM etc. have a lower 'average' output power and the assessed risk is even lower.



Versions of the IC-7700 which display the "CE" symbol on the serial number seal, comply with the essential requirements of the European Radio and Telecommunication Terminal Directive 1999/5/EC.



This warning symbol indicates that this equipment operates in non-harmonised frequency bands and/or may be subject to licensing conditions in the country of use. Be sure to check that you have the correct version of this radio or the correct programming of this radio, to comply with national licensing requirement.

• List of Country codes (ISO 3166-1)

	Country	Codes		Country	Codes
1	Austria	AT	18	Liechtenstein	LI
2	Belgium	BE	19	Lithuania	LT
3	Bulgaria	BG	20	Luxembourg	LU
4	Croatia	HR	21	Malta	MT
5	Czech Republic	CZ	22	Netherlands	NL
6	Cyprus	CY	23	Norway	NO
7	Denmark	DK	24	Poland	PL
8	Estonia	EE	25	Portugal	PT
9	Finland	FI	26	Romania	RO
10	France	FR	27	Slovakia	SK
11	Germany	DE	28	Slovenia	SI
12	Greece	GR	29	Spain	ES
13	Hungary	HU	30	Sweden	SE
14	Iceland	IS	31	Switzerland	CH
15	Ireland	IE	32	Turkey	TR
16	Italy	IT	33	United Kingdom	GB
17	Latvia	LV			



We Icom Inc. Japan
1-1-32, Kamiminami, Hirano-ku
Osaka 547-0003, Japan

Declare on our sole responsibility that this equipment complies with the essential requirements of the Radio and Telecommunications Terminal Equipment Directive, 1999/5/EC, and that any applicable Essential Test Suite measurements have been performed.

Kind of equipment: HF/50 MHz ALL MODE TRANSCEIVER

Type-designation: IC-7700

Version (where applicable): _____

This compliance is based on conformity with the following harmonised standards, specifications or documents:

- i) EN 301489-1 v1.4.1 (2002-08)
- ii) EN 301489-15 v1.2.1 (2002-08)
- iii) EN 301 783 v1.1.1 (2000-09)
- iv) EN 60950-1 (2001):A11:2004

DECLARATION OF CONFORMITY



Düsseldorf 30th Nov.2007
Place and date of issue

Icom (Europe) GmbH
Himmelgeisterstraße 100
D-40225 Düsseldorf

Authorized representative name
H. Ikegami
General Manager

Signature

Icom Inc.

Please record the serial number of your IC-7700 transceiver below for future servicing reference:

Serial Number :

Date of purchase :

Place where purchased :

Count on us!

IC-7700
#03 (Europe)

<Intended Country of Use>	
<input type="checkbox"/> AT	<input type="checkbox"/> BE <input type="checkbox"/> CY <input type="checkbox"/> CZ <input type="checkbox"/> DK <input type="checkbox"/> EE
<input type="checkbox"/> FI	<input type="checkbox"/> FR <input type="checkbox"/> DE <input type="checkbox"/> GR <input type="checkbox"/> HU <input type="checkbox"/> IE
<input type="checkbox"/> IT	<input type="checkbox"/> LV <input type="checkbox"/> LT <input type="checkbox"/> LU <input type="checkbox"/> MT <input type="checkbox"/> NL
<input type="checkbox"/> PL	<input type="checkbox"/> PT <input type="checkbox"/> SK <input type="checkbox"/> SI <input type="checkbox"/> ES <input type="checkbox"/> SE
<input type="checkbox"/> GB	<input type="checkbox"/> IS <input type="checkbox"/> LI <input type="checkbox"/> NO <input type="checkbox"/> CH <input type="checkbox"/> BG
<input type="checkbox"/> RO	<input type="checkbox"/> TR <input type="checkbox"/> HR

IC-7700
#04 (France)

<Intended Country of Use>	
<input type="checkbox"/> AT	<input type="checkbox"/> BE <input type="checkbox"/> CY <input type="checkbox"/> CZ <input type="checkbox"/> DK <input type="checkbox"/> EE
<input type="checkbox"/> FI	<input type="checkbox"/> FR <input type="checkbox"/> DE <input type="checkbox"/> GR <input type="checkbox"/> HU <input type="checkbox"/> IE
<input type="checkbox"/> IT	<input type="checkbox"/> LV <input type="checkbox"/> LT <input type="checkbox"/> LU <input type="checkbox"/> MT <input type="checkbox"/> NL
<input type="checkbox"/> PL	<input type="checkbox"/> PT <input type="checkbox"/> SK <input type="checkbox"/> SI <input type="checkbox"/> ES <input type="checkbox"/> SE
<input type="checkbox"/> GB	<input type="checkbox"/> IS <input type="checkbox"/> LI <input type="checkbox"/> NO <input type="checkbox"/> CH <input type="checkbox"/> BG
<input type="checkbox"/> RO	<input type="checkbox"/> TR <input type="checkbox"/> HR

IC-7700
#05 (Italy)

<Intended Country of Use>	
<input type="checkbox"/> AT	<input type="checkbox"/> BE <input type="checkbox"/> CY <input type="checkbox"/> CZ <input type="checkbox"/> DK <input type="checkbox"/> EE
<input type="checkbox"/> FI	<input type="checkbox"/> FR <input type="checkbox"/> DE <input type="checkbox"/> GR <input type="checkbox"/> HU <input type="checkbox"/> IE
<input type="checkbox"/> IT	<input type="checkbox"/> LV <input type="checkbox"/> LT <input type="checkbox"/> LU <input type="checkbox"/> MT <input type="checkbox"/> NL
<input type="checkbox"/> PL	<input type="checkbox"/> PT <input type="checkbox"/> SK <input type="checkbox"/> SI <input type="checkbox"/> ES <input type="checkbox"/> SE
<input type="checkbox"/> GB	<input type="checkbox"/> IS <input type="checkbox"/> LI <input type="checkbox"/> NO <input type="checkbox"/> CH <input type="checkbox"/> BG
<input type="checkbox"/> RO	<input type="checkbox"/> TR <input type="checkbox"/> HR

IC-7700
#06 (Spain)

<Intended Country of Use>	
<input type="checkbox"/> AT	<input type="checkbox"/> BE <input type="checkbox"/> CY <input type="checkbox"/> CZ <input type="checkbox"/> DK <input type="checkbox"/> EE
<input type="checkbox"/> FI	<input type="checkbox"/> FR <input type="checkbox"/> DE <input type="checkbox"/> GR <input type="checkbox"/> HU <input type="checkbox"/> IE
<input type="checkbox"/> IT	<input type="checkbox"/> LV <input type="checkbox"/> LT <input type="checkbox"/> LU <input type="checkbox"/> MT <input type="checkbox"/> NL
<input type="checkbox"/> PL	<input type="checkbox"/> PT <input type="checkbox"/> SK <input type="checkbox"/> SI <input type="checkbox"/> ES <input type="checkbox"/> SE
<input type="checkbox"/> GB	<input type="checkbox"/> IS <input type="checkbox"/> LI <input type="checkbox"/> NO <input type="checkbox"/> CH <input type="checkbox"/> BG
<input type="checkbox"/> RO	<input type="checkbox"/> TR <input type="checkbox"/> HR

IC-7700
#07 (United
Kingdom)

<Intended Country of Use>	
<input type="checkbox"/> AT	<input type="checkbox"/> BE <input type="checkbox"/> CY <input type="checkbox"/> CZ <input type="checkbox"/> DK <input type="checkbox"/> EE
<input type="checkbox"/> FI	<input type="checkbox"/> FR <input type="checkbox"/> DE <input type="checkbox"/> GR <input type="checkbox"/> HU <input type="checkbox"/> IE
<input type="checkbox"/> IT	<input type="checkbox"/> LV <input type="checkbox"/> LT <input type="checkbox"/> LU <input type="checkbox"/> MT <input type="checkbox"/> NL
<input type="checkbox"/> PL	<input type="checkbox"/> PT <input type="checkbox"/> SK <input type="checkbox"/> SI <input type="checkbox"/> ES <input type="checkbox"/> SE
<input type="checkbox"/> GB	<input type="checkbox"/> IS <input type="checkbox"/> LI <input type="checkbox"/> NO <input type="checkbox"/> CH <input type="checkbox"/> BG
<input type="checkbox"/> RO	<input type="checkbox"/> TR <input type="checkbox"/> HR

Icom Inc.

1-1-32 Kamiminami, Hirano-ku, Osaka 547-0003, Japan