



INSTRUCTION MANUAL

SEPARATION KIT
RMK-4

Icom Inc.

FOREWORD

Thank you for purchasing the RMK-4 SEPARATION KIT. The RMK-4 allows you to connect the additional CONTROL HEAD to the IC-F9511HT to enable dual-head operation. Depending on the length of separation you need, use either the optional OPC-607, OPC-608, OPC-609 or OPC-726 SEPARATION CABLE with the RMK-4.

EXPLICIT DEFINITIONS

WORD	DEFINITION
⚠ WARNING	Personal injury, fire hazard or electric shock may occur.
CAUTION	Equipment damage may occur.
NOTE	If disregarded, inconvenience only. No risk of personal injury, fire or electric shock.

 Please refer to the instruction manual of the transceiver for details of the basic operation.

Icom, Icom Inc. and the Icom logo are registered trademarks of Icom Incorporated (Japan) in Japan, the United States, the United Kingdom, Germany, France, Spain, Russia and/or other countries.
All other products or brands are registered trademarks or trademarks of their respective holders.

PRECAUTIONS

⚠ WARNING! NEVER place the transceiver's main unit (with the RMK-4) and CONTROL HEADs where normal operation of the vehicle may be hindered or where they could cause bodily injury.

CAUTION! To avoid damage to the transceiver, turn the power OFF and disconnect the DC power cable from the transceiver's main unit before disassemble the transceiver.

DO NOT use or place the transceiver's main unit (with the RMK-4) and CONTROL HEADs in areas with temperatures below -30°C (-22°F) or above $+60^{\circ}\text{C}$ ($+140^{\circ}\text{F}$).

DO NOT use chemical agents such as benzine or alcohol when cleaning, as they can damage the RMK-4 and CONTROL HEAD's surfaces.

USE the specified microphone only. Other microphones have different pin assignments and may damage CONTROL HEAD or the transceiver's main unit.

KEEP the transceiver's main unit (with the RMK-4) and CONTROL HEADs away from heavy rain, and never immerse them in the water.

The transceiver's main unit (with the RMK-4) and CONTROL HEADs meet IP54 requirements for dust-protection and splash resistance when the optional microphone*, the front/rear plate(s) and the speaker jack cover of CONTROL HEAD are attached.

However, if these items are dropped, dust-protection and splash resistance cannot be guaranteed because of possible damage to the cases or the waterproof seals.

* The microphone is not dust-protection and splash resistant.

ACCESSORIES

Second CONTROL HEAD

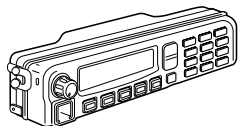

RMK-4 (Main unit attachment)

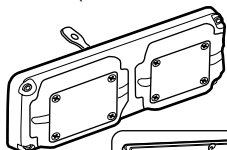

The serial number seal is put here, and labeled "RMK-4."

Key caps



Microphone hanger and screw set



Function name stickers

- Used for labelling the programmable function keys. See at right for details.

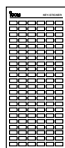

Mounting bracket for CONTROL HEAD

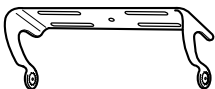

Flat washers (M5)



Spring washers (M5)



Nuts (M5)



Mounting screws (M5×12)



Self-tapping screws (M5×16)



Bracket screws



• Function name stickers

There are no labels on the programmable function keys since the functions can be freely assigned to these keys.

Attach the supplied function name stickers to the appropriate keys for easy recognition of the key's assigned function as shown below.

Then, protect the attached stickers from coming off with the supplied key cap, as shown below.

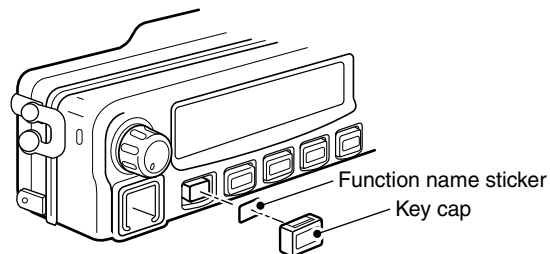
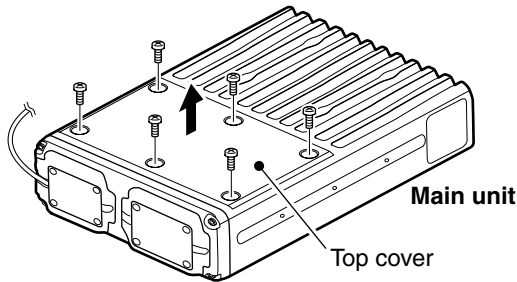

TABLE OF CONTENTS

FOREWORD	i
EXPLICIT DEFINITIONS.....	i
PRECAUTIONS.....	i
ACCESSORIES.....	ii
TABLE OF CONTENTS.....	iii
1 CONNECTION.....	1-5
■ Removing the transceiver's main unit attachment.....	1
■ Connecting CONTROL HEAD and RMK-4	2
■ Attaching the RMK-4	4
■ Mounting	4
2 REMOTE BOX SET MODE	6-8
■ Set mode items	6
3 DUAL-HEAD OPERATION.....	9-10
■ Intercom function.....	9
■ TX AF Monitoring function.....	10
■ NOTES	10
4 OPTIONS.....	11

■ Removing the transceiver's main unit attachment

- ① Turn the power OFF, then disconnect the DC power cable from the transceiver's main unit.
- ② Unscrew the 6 top screws, then remove the top cover from the transceiver's main unit in the direction of the arrow.



- ③ Unscrew the screw that is attached to the chassis.

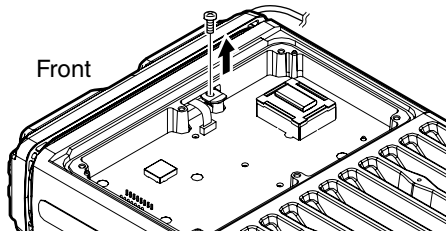

- ④ Unscrew the 4 front screws, then remove the main unit attachment from the main unit in the direction of the arrow.
 - The flat cable should be carefully disconnected from the attachment.

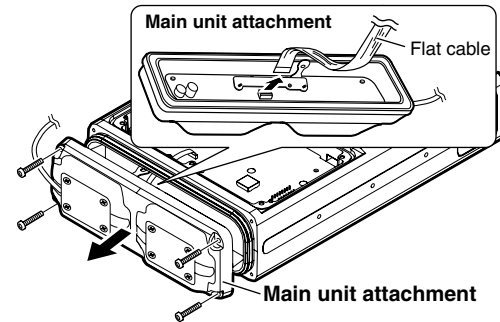

- ⑤ Unscrew the 4 screws, then remove the front plate from the main unit attachment. Then unscrew the circuit board screw, and disconnect the separation cable, if it is connected.

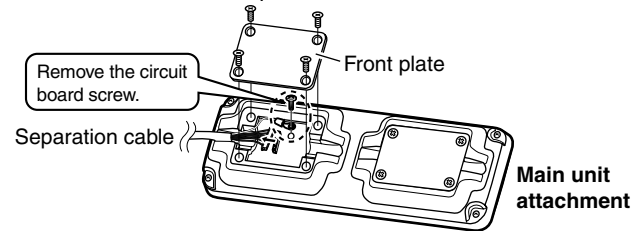

IMPORTANT: Set the top, chassis and front screws aside as they are needed for the RMK-4 installation.

1 CONNECTION

■ Connecting CONTROL HEAD and RMK-4

Either the optional OPC-607 (3 m; 9.84 ft), OPC-608 (8 m; 26.3 ft), OPC-609 (1.9 m; 6.3 ft) or OPC-726 (5 m; 16.4 ft) SEPARATION CABLE is required for CONTROL HEADs and the RMK-4 connections.

/// INFORMATION: CONTROL HEAD connected to the [CONTROL HEAD 1] of the RMK-4, is recognized as the main CONTROL HEAD.

◇ CONTROL HEAD

You can connect the separation cable to both CONTROL HEADs in the same way, as shown below.

- ① Unscrew the 4 screws, then remove the rear plate from CONTROL HEAD.

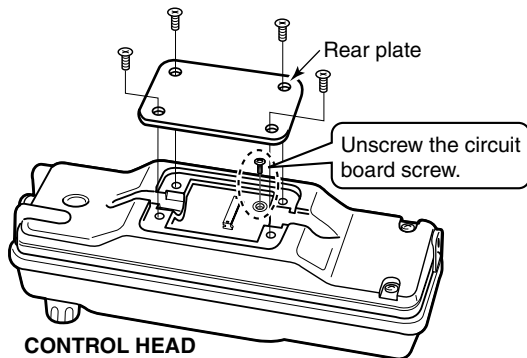

- ② Connect the separation cable to CONTROL HEAD.
 - The cable can be inserted into either the left or right grooves as needed.

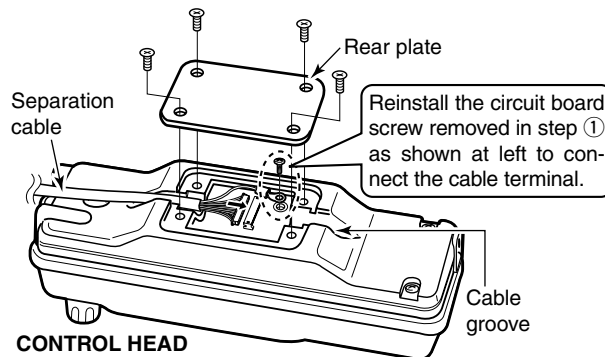

- ③ After the cable is connected, reinstall the rear plate and the 4 screws, then connect the opposite side of the separation cable to the RMK-4.
- ④ Repeat steps ① to ③ to attach the other CONTROL HEAD.

/// If the separation cable is already connected to the original CONTROL HEAD, the above connection should be performed to the second CONTROL HEAD only.

◇ RMK-4

- ① Unscrew the 4 screws, then remove the front plate from the RMK-4.

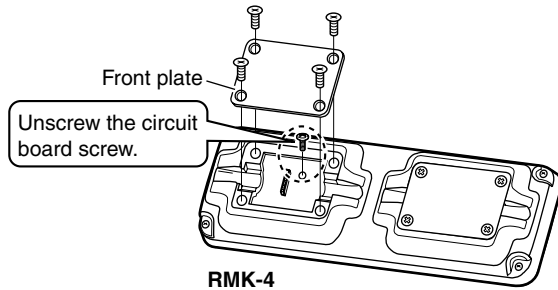

- ② Connect the opposite side of the separation cable that is connected to CONTROL HEAD to the RMK-4. After the cable is connected, reinstall the front plate and the 4 screws.
- The cable can be inserted into either the left or right grooves as needed.

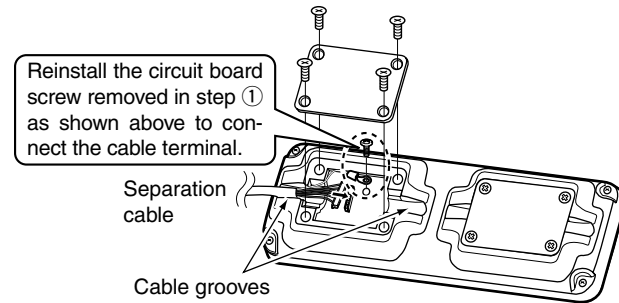

- ③ Repeat steps ① and ② for the other side connection.

1 CONNECTION

■ Attaching the RMK-4

- ① Carefully connect the flat cable of the transceiver's main unit to the RMK-4 as shown below (①). Then, attach the RMK-4 to the transceiver's main unit using 4 front screws that were removed from the main unit in step ④ in p. 1. (②)
 - Ensure the flat cable and the RMK-4 are connected/attached correctly, and not upside down.
- ② Replace the screw that was removed from the main unit in step ③ in p. 1 to the chassis. (③)

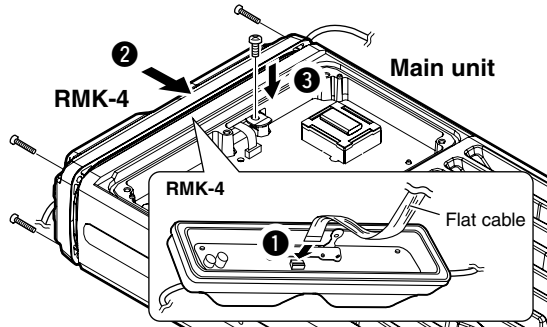

- ③ Replace the top cover and 6 top screws removed in step ② in p. 1, then reconnect the DC power cable.

■ Mounting

2 types of mounting styles are available— one is on-board mounting, and the other one is overhead mounting.

◇ On-board mounting

Mount the controller securely with the 4 supplied screws to a solid surface.

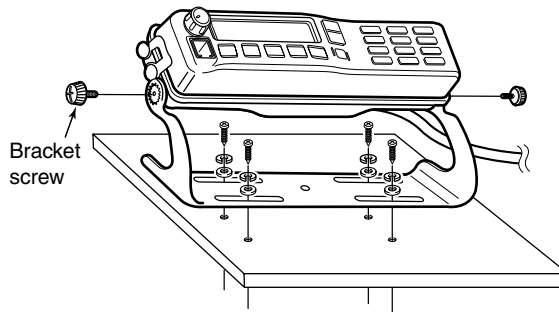

◇ **Overhead mounting**

Mount the controller securely with the 4 supplied screws to a solid surface which can support more than 2 kg (4.40 lb).
(Overhead mounting)

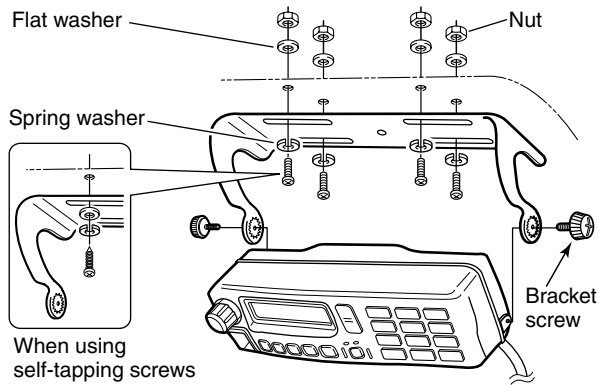

The REMOTE BOX SET MODE is accessed at power ON and allows you to set seldom-changed settings. You can “customize” CONTROL HEADs for dual-head operation to suit your preferences and operating style.

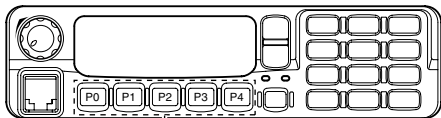

*In this instruction manual, these keys are from the left, designated [P0]/[P1]/[P2]/[P3]/[P4].

◇ Set mode operation

- ① First, be sure power is OFF. Then, while pushing and holding [P0], [P1] and [P2], push [⏻] to turn the power ON.
 - Hold [P0], [P1] and [P2] until “SET MODE FOR REMOTE BOX” appears on the display.
- ② Push [P0] to enter the REMOTE BOX SET MODE.
- ③ Then push [P0] additional times to select the appropriate item. Then, push [Up] or [Down] to set the desired level and conditions.
- ④ Push and hold [⏻] to exit the REMOTE BOX SET MODE.

▨ The USER SET MODE is also available. The common functions that can be used with both dual-head and single-head operations are set in the USER SET MODE. Please refer to the instruction manual of the transceiver for details.

■ Set mode items

The following functions (other than “RX Speaker Tune”) can be programmed into CONTROL HEADs 1 and 2, individually.

◇ AF Minimum

Set the AF Minimum function to ON or OFF. (default: ON)

ON : The minimum audio output level is set for CONTROL HEADs.

- Set the minimum audio output level in “AF Minimum Level” as shown below.

OFF : The minimum audio output level is not set for CONTROL HEADs.

◇ AF Minimum Level

Set the minimum audio output level between 0 and 255. (default: 0)

This setting is effective only when “AF Minimum” is ON as shown above.

◇ Beep Level

Set the output level of the confirmation beeps between 1 and 5. (default: 3)

This setting is effective for dual-head operation functions only. The beep level for other functions that can be used with both dual-head and single-head operations, are set in the USER SET MODE.

◇ Panel Lock function

Set the Panel Lock function to ON or OFF. (default: ON)
The Panel Lock function locks all keys and the dial other than [⓪] and [P4 (PANEL LOCK)].

ON : The [PANEL LOCK] function is assigned to [P4], and you can toggle the Panel Lock function ON and OFF with pushing and holding [P4 (PANEL LOCK)] for 1 sec.

OFF : [P4] retains the originally programmed function and the Panel Lock function is OFF.

 **NOTE:** When this function is set to ON, the key function [Null] must be assigned to [P4] by the CS-F9010/F9510 CLONING SOFTWARE on both CONTROL HEADs for matching the CONTROL HEAD's performance. Ask your dealer for details.

◇ TX AF Monitoring function

Set the TX AF Monitoring function to ON or OFF. (default: ON)
This function allows the operator of CONTROL HEAD to monitor the other side's communication.

When one CONTROL HEAD operator is communicating, the audio can be heard from the SP-22 EXTERNAL SPEAKER on the other CONTROL HEAD side.

The optional SP-22 EXTERNAL SPEAKER is required.

◇ Hanger function

Set the Hanger function to ON or OFF. (default: ON)
The microphone "on-hook" function (Hook-on scan) and "off-hook" functions (Move to Priority A CH and Monitor) are activated according to this setting.

ON : The microphone "on-hook" or "off-hook" functions are activated when CONTROL HEAD's microphone is put on (on hook) or taken off (off-hook) it's hanger hook.

OFF : The microphone "on-hook" function is activated regardless of the CONTROL HEAD's microphone "on-hook" and "off-hook".

 **NOTE:** If "ON" is set in both CONTROL HEADs and one of the two microphones is taken from its hanger hook, the microphone "off-hook" functions are activated for both CONTROL HEADs.

2 REMOTE BOX SET MODE

◇ RX Speaker Tuning function

Set the RX Speaker Tuning function to ON or OFF for CONTROL HEAD 1 (main). (default: OFF)

This function allows the operator of CONTROL HEAD 1 to adjust the output level of the external speaker that is connected to the transceiver's main unit.

ON : The audio output level of the external speaker is adjustable with the AF volume control knob on CONTROL HEAD 1.

The minimum audio output level must be set to more than 1 on the transceiver's main unit in order to avoid muting the audio output.

OFF : The audio output level of the external speaker is not adjustable by CONTROL HEADS.

◇ Intercom function

Set the Intercom function to ON or OFF. (default: ON)

The Intercom function allows CONTROL HEAD operators to communicate each other via their microphones.

The optional microphone and the SP-22 EXTERNAL SPEAKER are required.

ON : The [INTERCOM] function is assigned to [P3], and you can enter and exit the Intercom mode by pushing [P3 (INTERCOM)].

OFF : [P3] retains the originally programmed function and the Intercom function is OFF.

NOTE:

- When one CONTROL HEAD enters the Intercom mode, the other CONTROL HEAD also enters even if this function is set to OFF.
- When this function is set to ON, the key function [Null] must be assigned to [P3] by the CS-F9010/F9510 CLONING SOFTWARE on both CONTROL HEADs for matching the CONTROL HEAD's performance. Ask your dealer for details.

■ Intercom function

[P3] is used for the Intercom function ON/OFF switch when the Intercom function is set to ON in the REMOTE BOX SET MODE. (No other function can be assigned.)

The Intercom function allows the operators of CONTROL HEAD 1 and 2 to communicate each other via their microphones.

The optional microphone and the SP-22 EXTERNAL SPEAKER are required.

NOTE:

- Transmitting is impossible during intercom operation.
- During intercom operation, when [PTT] is pushed and held on the caller's side, any received radio signal is muted on the listener side's CONTROL HEAD external speaker. However, the received radio signal can be heard on the caller side's CONTROL HEAD external speaker and the main unit's external speaker.
- When the message signal is received, it is not displayed on the LCD of CONTROL HEADs during intercom operation. After exiting the intercom mode, it will be displayed on the LCD.
- During intercom operation, CONTROL HEADs 1 and 2 return to the normal operation mode, if no [PTT] operation is performed for 30 sec.

- ① Push [P3 (INTERCOM)] to enter the intercom mode.
 - The other CONTROL HEAD is also set to the Intercom mode automatically even if this function is set to OFF.
 - "INTERCOM" appears on both CONTROL HEADs.
- ② Push and hold [PTT] and speak at a normal voice level into the microphone.
 - "IN USE" blinks on the listener side.
 - To adjust the audio output level, rotate [VOL].
- ③ After releasing [PTT] you can hear the response through the speaker.
- ④ To return to normal operation, push [P3 (INTERCOM)].

3 DUAL-HEAD OPERATION

■ TX AF Monitoring function

When the TX AF Monitoring function is set to ON in the REMOTE BOX SET MODE, and one CONTROL HEAD operator is communicating, the audio can be heard from the SP-22 EXTERNAL SPEAKER on the other CONTROL HEAD side. The optional SP-22 EXTERNAL SPEAKER is required.

NOTE: When one CONTROL HEAD operator is communicating, "IN USE" blinks on the other CONTROL HEAD's display and the TX indicators lights red.



■ NOTES

- Transmission can be performed on either CONTROL HEADs 1 or 2 at the same time.
- The Power ON Password function will not work properly when attaching the RMK-4.
- The RMK-4 is not designed for the single-head operation. For single-head operation, use the original attachment and cable combination— no RMK-4 is necessary. But when the one of CONTROL HEADs is accidentally broken, the RMK-4 may go into the unintended single-head operation mode. In that case, the Intercom function **MUST** be turned OFF. Otherwise, any problem may occur.

- **OPC-607/OPC-608/OPC-609/OPC-726**

SEPARATION CABLES

Used for CONTROL HEAD and the RMK-4 connection.

OPC-607 : 3 m; 9.84 ft

OPC-608 : 8 m; 26.3 ft

OPC-609 : 1.9 m; 6.3 ft

OPC-726 : 5 m; 16.4 ft

- **HM-152/HM-152T/HM-148G/HM-148T** HAND MICROPHONES

HM-152 : Hand microphone

HM-152T : DTMF microphone

HM-148G: Self grounding heavy duty microphone

HM-148T : Self grounding heavy duty DTMF microphone

- **SM-25** DESKTOP MICROPHONE

- **SP-22** EXTERNAL SPEAKER

Compact and easy-to-install.

Input impedance : 4 Ω

Max. input power : 5 W

*The SP-22 is not recommended for use with the IC-F9511HT.

Use the SP-30 instead.

Icom optional equipment are designed for optimal performance when used with this transceiver. We are not responsible for the transceiver being damaged or any accident caused when using non-Icom optional equipment.

Some options may not available in some countries. Please ask your dealer for details.

Count on us!

A-6757H-1US
Printed in Japan
© 2009 Icom Inc.

Printed on recycled paper with soy ink.

Icom Inc.

1-1-32 Kamiminami, Hirano-ku, Osaka 547-0003, Japan