



INSTRUCTION MANUAL

VHF MARINE TRANSCEIVER

IC-M330
IC-M330E
IC-M330G
IC-M330GE

This device complies with Part 15 of the FCC rules. Operation is subject to the condition that this device does not cause harmful interference.

Picture In Progress

Thank you for choosing this Icom product.

This product is designed and built with Icom's state of the art technology and craftsmanship. With proper care, this product should provide you with years of trouble-free operation.

IMPORTANT

READ ALL INSTRUCTIONS carefully and completely before using the transceiver.

SAVE THIS INSTRUCTION MANUAL — This instruction manual contains important operating instructions for the IC-M330, IC-M330E, IC-M330G, IC-M330GE.

This instruction manual includes some functions which are usable only when they are preset by your dealer.

Ask your dealer for details.

Icom is not responsible for the destruction, damage to, or performance of any Icom or non-Icom equipment, if the malfunction is because of:

- Force majeure, including, but not limited to, fires, earthquakes, storms, floods, lightning, other natural disasters, disturbances, riots, war, or radioactive contamination.
- The use of Icom transceivers with any equipment that is not manufactured or approved by Icom.

FEATURES

- **Easy user interface**
The transceiver is equipped with a screen for easy readability and easy-to-use user interface.
- **Dualwatch and Tri-watch functions**
Convenient functions that enable you to monitor the Distress channel (Ch 16) while receiving on another channel of your choice (Dualwatch), or while receiving on another channel of your choice, and the Call channel (Tri-watch).
* May not be usable depending on the transceiver version.
- **DSC functions**
The transceiver has the DSC functions for distress alert transmission and reception, as well as the general DSC calls such as Individual calls, All ships calls, Group calls, and so on.

EXPLICIT DEFINITIONS

WORD	DEFINITION
⚠WARNING!	Personal injury, fire hazard or electric shock may occur.
CAUTION	Equipment damage may occur.
NOTE	If disregarded, inconvenience only. No risk of personal injury, fire or electric shock.

IN CASE OF EMERGENCY

If your vessel requires assistance, contact other vessels and the Coast Guard by sending a distress call on Channel 16.

USING CHANNEL 16 DISTRESS CALL PROCEDURE

1. "MAYDAY MAYDAY MAYDAY."
2. "THIS IS" (name of vessel).
3. Say your call sign or other indication of the vessel (AND your 9 digit DSC ID, if you have one).
4. "LOCATED AT" (your position).
5. State the nature of the distress and assistance required.
6. Give any other information which might facilitate the rescue.

Or, transmit your Distress call using Digital Selective Calling (DSC) on Channel 70.

USING DIGITAL SELECTIVE CALLING (Ch 70) DISTRESS CALL PROCEDURE

1. While lifting up the key cover, hold down [DISTRESS] for 3 seconds until you hear 3 short beeps and then one long beep.
2. Wait for an acknowledgment on Channel 70 from a coast station.
 - After the acknowledgement is received, Channel 16 is automatically selected.
3. Hold down [PTT], then transmit the appropriate information as listed to the left.

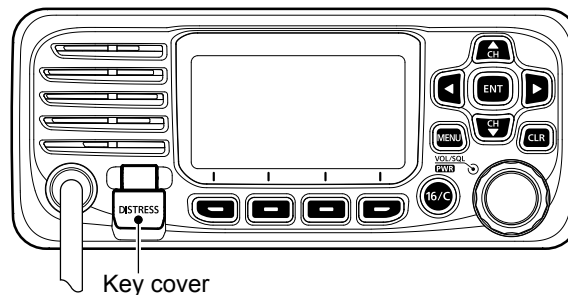

RADIO OPERATION WARNING



Icom requires the radio operator to meet the FCC Requirements for Radio Frequency Exposure. An omnidirectional antenna with gain not greater than 9 dBi must be mounted a minimum of 5 meters (measured from the lowest point of the antenna) vertically above the main deck and all possible personnel. This is the minimum safe separation distance estimated to meet all RF exposure compliance requirements. This 5 meter distance is based on the FCC Safe Maximum Permissible Exposure (MPE) distance of 3 meters added to the height of an adult (2 meters) and is appropriate for all vessels.

For watercraft without suitable structures, the antenna must be mounted so as to maintain a minimum of 1 meter vertically between the antenna, (measured from the lowest point of the antenna), to the heads of all persons AND all persons must stay outside of the 3 meter MPE radius.

Do not transmit with radio and antenna when persons are within the MPE radius of the antenna, unless such persons (such as driver or radio operator) are shielded from antenna field by a grounded metallic barrier. The MPE Radius is the minimum distance from the antenna axis that person should maintain in order to avoid RF exposure higher than the allowable MPE level set by FCC.

FAILURE TO OBSERVE THESE LIMITS MAY ALLOW THOSE WITHIN THE MPE RADIUS TO EXPERIENCE RF RADIATION ABSORPTION WHICH EXCEEDS THE FCC MAXIMUM PERMISSIBLE EXPOSURE (MPE) LIMIT. IT IS THE RESPONSIBILITY OF THE RADIO OPERATOR TO ENSURE THAT THE MAXIMUM PERMISSIBLE EXPOSURE LIMITS ARE OBSERVED AT ALL TIMES DURING RADIO TRANSMISSION. THE RADIO OPERATOR IS TO ENSURE THAT NO BYSTANDERS COME WITHIN THE RADIUS OF THE MAXIMUM PERMISSIBLE EXPOSURE LIMITS.

**Determining MPE Radius
THE MAXIMUM PERMISSIBLE EXPOSURE (MPE) RADIUS HAS BEEN ESTIMATED TO BE A RADIUS OF ABOUT 3M PER OET BULLETIN 65 OF THE FCC. THIS ESTIMATE IS MADE ASSUMING THE MAXIMUM POWER OF THE RADIO AND ANTENNAS WITH A MAXIMUM GAIN OF 9dBi ARE USED FOR A SHIP MOUNTED SYSTEM.**

AVERTISSEMENT POUR LES OPÉRATEURS RADIO



AVERTISSEMENT

Icom exige que l'opérateur radio se conforme aux exigences de la FCC en matière d'exposition aux radiofréquences. Une antenne omnidirectionnelle dont le gain ne dépasse pas 9dBi doit être fixée à une distance minimale de 5 mètres (mesurée depuis le point le plus bas de l'antenne)

verticalement au-dessus du pont principal et de tout le personnel qui peut s'y trouver. Il s'agit de la distance de sécurité minimale prévue pour satisfaire aux exigences de conformité en matière d'exposition aux RF. Cette distance de 5 mètres est établie en fonction de l'exposition maximale admissible sécuritaire de 3 mètres établie par la FCC, à laquelle on ajoute la hauteur d'un adulte (2 mètres); cette distance convient pour tous les navires.

Dans le cas des embarcations sans structure convenable, l'antenne doit être fixée de façon à maintenir une distance minimale de 1 mètre verticalement entre cette antenne (mesurée depuis son point le plus bas) et la tête de toute personne présente; toutes les personnes présentes doivent se tenir à l'extérieur d'un rayon d'exposition maximale admissible de 3 mètres.

Ne pas émettre à l'aide de la radio et de l'antenne lorsque des personnes se trouvent à l'intérieur du rayon d'exposition maximale admissible de cette antenne, à moins que ces personnes (comme le conducteur ou l'opérateur radio) ne soient protégées du champ de l'antenne par un écran métallique relié à la masse. Le rayon d'exposition maximale admissible équivaut à la distance minimale que cette personne doit maintenir entre elle et l'axe de l'antenne pour éviter une exposition aux RF supérieure au niveau d'exposition maximale admissible fixé par la FCC.

LE NON-RESPECT DE CES LIMITES PEUT CAUSER, POUR LES PERSONNES SITUÉES DANS LE RAYON D'EXPOSITION MAXIMALE ADMISSIBLE, UNE ABSORPTION DE RAYONNEMENT DE RF SUPÉRIEURE À L'EXPOSITION MAXIMALE ADMISSIBLE FIXÉE PAR LA FCC.

L'OPÉRATEUR RADIO EST RESPONSABLE D'ASSURER QUE LES LIMITES D'EXPOSITION MAXIMALE ADMISSIBLE SOIENT RESPECTÉES EN TOUT TEMPS PENDANT LA TRANSMISSION RADIO. L'OPÉRATEUR RADIO DOIT S'ASSURER QU'AUCUNE PERSONNE PRÉSENTE NE SE SITUE À L'INTÉRIEUR DU RAYON D'EXPOSITION MAXIMALE ADMISSIBLE.

Établir le rayon d'exposition maximale admissible ON ESTIME QUE LE RAYON D'EXPOSITION MAXIMALE ADMISSIBLE EST D'ENVIRON 3 M, TEL QUE STIPULÉ DANS LE BULLETIN OET 65 DE LA FCC. CETTE DISTANCE ESTIMÉE TIENT COMPTE D'UN SYSTÈME INSTALLÉ SUR UN NAVIRE UTILISANT LA PUISSANCE MAXIMALE DE LA RADIO ET DES ANTENNES DONT LE GAIN MAXIMAL EST DE 9dBi.

FCC INFORMATION

This equipment has been tested and found to comply with the limits for a Class A digital device, pursuant to part 15 of the FCC Rules. These limits are designed to provide reasonable protection against harmful interference when the equipment is operated in a commercial environment. This equipment generates, uses, and can radiate radio frequency energy and, if not installed and used in accordance with the instruction manual, may cause harmful interference to radio communications.

Operation of this equipment in a residential area is likely to cause harmful interference in which case the user will be required to correct the interference at his own expense.

CAUTION: Changes or modifications to this device, not expressly approved by Icom Inc., could void your authority to operate this device under FCC regulations.

NOTE

A WARNING STICKER is supplied with the USA version transceiver.

To comply with FCC regulations, this sticker must be affixed in such a location as to be readily seen from the operating controls of the radio as in the diagram below. Make sure the chosen location is clean and dry before applying the sticker.

EXAMPLE



PRECAUTIONS

⚠ **WARNING! NEVER** connect the transceiver directly to an AC outlet. This may cause a fire or an electric shock.

⚠ **WARNING! NEVER** connect the transceiver to a power source of more than 16 V DC such as a 24 V battery. This connection could cause a fire or damage the transceiver.

⚠ **WARNING! NEVER** reverse the DC power cable polarity when connecting to a power source. This could damage the transceiver.

⚠ **WARNING! NEVER** cut the DC power cable between the DC plug at the back of the transceiver and the fuse holder. If an incorrect connection is made after cutting, the transceiver may be damaged.

⚠ **WARNING! NEVER** operate the transceiver during a lightning storm. It may result in an electric shock, cause a fire or damage the transceiver. Always disconnect the power source and antenna before a storm.

⚠ **WARNING! NEVER** place the transceiver where normal operation of the vessel may be hindered, or where it could cause bodily injury.

CAUTION: KEEP the transceiver and microphone at least 1 meter away from the vessel's magnetic navigation compass.

CAUTION: DO NOT place or leave the transceiver in areas with temperatures below $-20^{\circ}\text{C} \sim +60^{\circ}\text{C}$ ($-4^{\circ}\text{F} \sim +140^{\circ}\text{F}$), or in areas subject to direct sunlight, such as a dashboard.

CAUTION: DO NOT use harsh solvents such as Benzine or alcohol to clean the transceiver, as they will damage the transceiver's surfaces. If the transceiver becomes dusty or dirty, wipe it clean with a soft, dry cloth.

BE CAREFUL! The transceiver rear panel will become hot when transmitting continuously for long periods of time.

Place the transceiver in a secure place to avoid inadvertent use by unauthorized persons.

BE CAREFUL! The transceiver's front panel meets IPX7 requirements for waterproof protection*. However, once the transceiver or microphone has been dropped, or the waterproof seal is cracked or damaged, waterproof protection cannot be guaranteed because of possible damage to the case or the waterproof seal.

* Except for the DC power connector, NMEA In/Out leads and AF Out leads.

PRÉCAUTIONS

⚠ **AVERTISSEMENT ! NE JAMAIS** relier l'émetteur-récepteur à une prise CA. Cela pourrait provoquer un choc électrique ou un incendie.

⚠ **AVERTISSEMENT ! NE JAMAIS** brancher l'émetteur-récepteur sur une source d'alimentation supérieure à 16 V CC, comme une batterie de 24 V. Cela pourrait endommager l'émetteur-récepteur.

⚠ **AVERTISSEMENT ! NE JAMAIS** inverser la polarité du câble d'alimentation CC lors de la connexion à une source d'alimentation. Cela pourrait endommager l'émetteur-récepteur.

⚠ **AVERTISSEMENT ! NE JAMAIS** couper le câble d'alimentation CC entre la prise CC à l'arrière de l'émetteur-récepteur et le porte-fusible. L'émetteur-récepteur peut être endommagé par la suite en cas de connexion inappropriée.

⚠ **AVERTISSEMENT ! NE JAMAIS** utiliser l'émetteur-récepteur durant un orage. Cela risquerait de provoquer un choc électrique, un incendie ou d'endommager l'émetteur-récepteur. Toujours débrancher la source d'alimentation et l'antenne avant une tempête.

MISE EN GARDE : NE JAMAIS installer l'émetteur-récepteur à un emplacement où il pourrait gêner le fonctionnement normal du navire ou provoquer des blessures corporelles.

INSTALLER la VHF et le microphone à au moins 1 m du compas de route du navire.

NE PAS utiliser ou placer l'émetteur-récepteur dans des zones où la température est inférieure à -15° ou supérieure à $+55^{\circ}$ ou dans des zones soumises au rayonnement solaire direct, telles le tableau de bord.

NE PAS nettoyer l'appareil avec des solvants agressifs tels que benzène ou alcool, susceptibles d'endommager les surfaces exposées du boîtier. En cas de dépôt de poussière ou de salissures sur l'émetteur-récepteur, il faut l'essuyer avec chiffon doux et sec.

MISE EN GARDE ! La face arrière de la VHF chauffe en cas d'utilisation continue sur une longue durée.

Placer l'émetteur-récepteur hors de portée des enfants pour éviter toute utilisation inopinée.

MISE EN GARDE ! La face avant de l'émetteur-récepteur est étanche conformément à la norme IPX7*. L'étanchéité ne peut plus être garantie après une chute de l'appareil en raison des risques de fissures du boîtier, de dégradation du joint d'étanchéité, etc.

*Les connecteurs sur le panneau arrière ne sont pas étanche IPX7.

Si la face avant est exposée à de l'eau de mer, **ASSUREZ-VOUS DE LE NETTOYER ENTIÈREMENT AVEC DE L'EAU DOUCE** lorsque la protection étanche sur le panneau avant fonctionne. Dans le cas contraire, les touches et le commutateur risquent de ne plus fonctionner en raison de la cristallisation du sel.

COUNTRY CODE LIST

• List of Country codes (ISO 3166-1)

	Country	Codes		Country	Codes
1	Austria	AT	18	Liechtenstein	LI
2	Belgium	BE	19	Lithuania	LT
3	Bulgaria	BG	20	Luxembourg	LU
4	Croatia	HR	21	Malta	MT
5	Czech Republic	CZ	22	Netherlands	NL
6	Cyprus	CY	23	Norway	NO
7	Denmark	DK	24	Poland	PL
8	Estonia	EE	25	Portugal	PT
9	Finland	FI	26	Romania	RO
10	France	FR	27	Slovakia	SK
11	Germany	DE	28	Slovenia	SI
12	Greece	GR	29	Spain	ES
13	Hungary	HU	30	Sweden	SE
14	Iceland	IS	31	Switzerland	CH
15	Ireland	IE	32	Turkey	TR
16	Italy	IT	33	United Kingdom	GB
17	Latvia	LV			

DISPOSAL



The crossed-out wheeled-bin symbol on your product, literature, or packaging reminds you that in the European Union, all electrical and electronic products, batteries, and accumulators (rechargeable batteries) must be taken to designated collection locations at the end of their working life. Do not dispose of these products as unsorted municipal waste. Dispose of them according to the laws in your area.

ABOUT CE AND DOC



Hereby, Icom Inc. declares that the versions of IC-M330E/IC-M330GE which have the “CE” symbol on the product, comply with the essential requirements of the Radio Equipment Directive, 2014/53/EU, and the restriction of the use of certain hazardous substances in electrical and electronic equipment Directive, 2011/65/EU. The full text of the EU declaration of conformity is available at the following internet address:

<http://www.icom.co.jp/world/support>

RECOMMENDATION

CLEAN THE FRONT PANEL THOROUGHLY WITH FRESH WATER after exposure to saltwater, and dry it before operating. Otherwise, the front panel's keys, switches and controllers may become unusable, due to salt crystallization.

NOTE: If the front panel's waterproof protection appears defective, carefully clean it with a soft, wet (fresh water) cloth, then, dry it before operating.

The front panel may lose its waterproof protection if the case or connector cover is cracked or broken, or the transceiver has been dropped.

Contact your Icom distributor or your dealer for advice.

Icom, Icom Inc. and Icom logo are registered trademarks of Icom Incorporated (Japan) in Japan, the United States, the United Kingdom, Germany, France, Spain, Russia, Australia, New Zealand, and/or other countries.
AquaQuake™ is a trademark of Icom Incorporated.

INSTALLATION NOTE

Installation:

The installation of this equipment should be made in such a manner as to respect the EC recommended electromagnetic field exposure limits. (1999/519/EC)

The maximum RF power available from this device is 25 watts. The antenna should be installed as high as possible for maximum efficiency and the installation height should be at least 1.76 meters above any accessible position. In the case where an antenna cannot be installed at a reasonable height, then the transmitter should neither be continuously operated for long periods if any person is within a distance of 1.76 meters of the antenna, nor operated at all if any person is touching the antenna.

It is recommended that antenna of a maximum gain of 3 dB is used. If higher gain antenna are required then please contact your Icom distributor for revised installation recommendations.

Operation:

The exposure to RF electromagnetic field is only applicable when this device is transmitting. This exposure is naturally reduced due to the nature of alternating periods of receiving and transmitting. Keep your transmissions to the minimum necessary.

KEY ICON DESCRIPTION

The keys are described in this manual as followings:

- The keys which have an icon on it are described with the characters “[]”.
Example: [MENU], [CLR]
- The software keys are described with the icon such as **ENT** or **DISTRESS**. The function of the keys are shown at the bottom of the display. Push the key below the desired function.
- you can use the following keys in the Menu screen.

FUNCTION	ACTION
Select	Rotate [DIAL], or push [▼] or [▲].
Enter	Push [ENT], ENT , or [DIAL]
Go to the next tree level	Push [ENT], ENT , [DIAL], or [▶].
Go back to the previous tree level	Push [CLR], BACK , or [◀].
Cancel	Push [CLR].
Exit	Push [MENU] or EXIT

TABLE OF CONTENTS

IMPORTANT.....	ii
FEATURES.....	ii
EXPLICIT DEFINITIONS.....	ii
IN CASE OF EMERGENCY.....	iii
RADIO OPERATION WARNING.....	iv
AVERTISSEMENT POUR LES OPÉRATEURS RADIO.....	v
FCC INFORMATION.....	vi
NOTE.....	vi
PRECAUTIONS.....	vii
PRÉCAUTIONS.....	viii
COUNTRY CODE LIST.....	ix
DISPOSAL.....	ix
ABOUT CE AND DOC.....	ix
RECOMMENDATION.....	x
INSTALLATION NOTE.....	x
KEY ICON DESCRIPTION.....	xi
1. OPERATING RULES.....	1
2. PANEL DESCRIPTION.....	2
■ Front Panel.....	2
■ Function Display.....	3
■ Software keys.....	4
■ Microphone.....	6
3. PREPARATIONS.....	7
■ Entering the MMSI code.....	7
■ Entering the ATIS ID (For Dutch and German versions)....	8

TABLE OF CONTENTS

4. BASIC OPERATION	9	9. CONNECTIONS AND MAINTENANCE.....	33
■ Selecting a channel.....	9	■ Connections.....	33
■ Adjusting the volume level	11	■ Antenna.....	35
■ Adjusting the squelch level	11	■ Fuse replacement	35
■ Adjusting the backlight or the display contrast.....	12	■ Cleaning.....	35
■ Setting the Call channel.....	12	■ Supplied accessories	35
■ Receiving and transmitting.....	13	■ Mounting the transceiver.....	36
■ Microphone Lock function	13	■ MBF-5 installation	37
■ AquaQuake Water Draining function.....	14	■ Specifications.....	38
■ Editing a channel name	14	10. SPECIFICATIONS	38
5. SCAN OPERATION (Except for the Dutch Version).....	15	■ Options.....	39
■ Scan types	15		
■ Setting Favorite channels	16		
■ Starting a scan	16		
6. DUALWATCH/TRI-WATCH (Except for the Dutch Version) 17			
■ Description	17		
■ Operation	17		
■ DSC address ID	18		
7. DSC OPERATION	18		
■ Entering the position and time	20		
■ Sending DSC calls (Distress).....	21		
■ DSC Settings	24		
8. MENU SCREEN	27		
■ Using the Menu screen	27		
■ Menu items description	29		

◇ Priorities

- Read all rules and regulations pertaining to priorities and keep an up-to-date copy handy. Safety and distress calls take priority over all others.
- You must monitor Channel 16 when you are not operating on another channel.
- False or fraudulent distress calls are prohibited under law.

◇ Privacy

- Information overheard but not intended for you cannot lawfully be used in any way.
- Indecent or profane language is prohibited.

◇ Radio licenses

(1) SHIP STATION LICENSE

You must have a current radio station license before using the transceiver. It is unlawful to operate a ship station which is not licensed.

Inquire through your dealer or the appropriate government agency for a Ship-Radiotelephone license application. This government-issued license states the call sign which is your craft's identification for radio purposes.

(2) OPERATOR'S LICENSE

A Restricted Radiotelephone Operator Permit is the license most often held by small vessel radio operators when a radio is not required for safety purposes.

The Restricted Radiotelephone Operator Permit must be posted or kept with the operator. Only a licensed radio operator may operate a transceiver.

However, non-licensed individuals may talk over a transceiver if a licensed operator starts, supervises, ends the call and makes the necessary log entries.

A current copy of the applicable government rules and regulations is only required to be on hand for vessels in which a radio telephone is compulsory. However, even if you are not required to have these on hand it is your responsibility to be thoroughly acquainted with all pertinent rules and regulations.

NOTE: Even though the transceiver is capable of operation on VHF marine channels 3, 21, 23, 61, 64, 81, 82 and 83, according to FCC regulations these simplex channels cannot be lawfully used by the general population in USA waters.

■ Front Panel

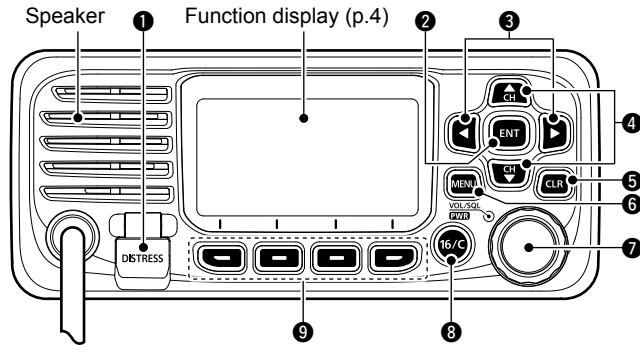

1 DISTRESS KEY [DISTRESS]

Hold down for 3 seconds to transmit a Distress call.

2 ENTER KEY

Push to set the entered data, selected item, and so on.

3 LEFT/RIGHT KEYS [◀]/[▶]

- Push to scroll the Software Key functions.
- Push to select a character or number in the entry mode.

4 UP/DOWN KEYS [▲]/[▼]

- Push to select an operating channel, Menu items, Menu settings, and so on.
- Push to select a character or number in the entry mode.

5 CLEAR KEY [CLR]

Push to cancel the entered data, or to return to the previous screen.

6 MENU KEY

Push to display or close the Menu screen.

7 POWER/VOLUME/SQUELCH SWITCH [PWR/VOL/SQL/DIAL]

- Hold down for 1 second to turn the transceiver ON or OFF.
- Push once to display the volume level setting screen, then rotate to adjust the volume level.
- Push twice to display the squelch level setting screen, then rotate to adjust the squelch level.
- Rotate to select an item in the Menu screen.
- Push to select a character or number, or rotate to move the cursor in the entry mode.

8 CHANNEL 16/CALL CHANNEL KEY [16/C]

- Push to select Channel 16.
- Hold down for 1 second to select the Call channel.

9 SOFTWARE KEYS

Scroll the key functions pushing [◀] or [▶], then push either of the 4 software keys to select the function displayed at the bottom of the display.
See "Software keys" on pages 4~5 for details.

■ Function Display

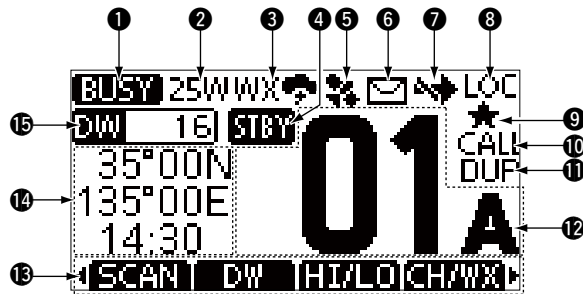

1 STATUS ICON

- TX: Displayed while transmitting.
- BUSY: Displayed while receiving, or the squelch is open.

2 POWER INDICATOR

- 25W: High power
- 1W: Low power

3 CHANNEL GROUP ICON

Displays the selected channel group, INT (International), USA, CAN (Canada), ATIS, WX (Weather channel), or DSC.

① The selectable channels differ, depending on the version or presets.

4 STATUS ICON

- STBY: Displayed when in the Standby mode.
- RT: Displayed when the channel is changed while receiving or transmitting a signal. (For only the USA version)

5 GPS ICON

- Displayed when valid GPS position data is received.
- Blinks while no position data is received.

6 MAIL ICON (Displayed when there is an unread DSC message.

- Blinks until one of the called messages is read.

7 CHANNEL SWITCH ICON

- Displayed when the “CH Auto Switch” is set to “Ignore” or “Manual”
- Blinks when the “DSC Switch” is OFF.

8 LOCAL ICON

Displayed when the RF Attenuation is ON. (For only the USA version)

9 FAVORITE CHANNEL ICON

Displayed when a Favorite channel is selected.

10 CALL CHANNEL ICON

Displayed when a Call channel is selected.

11 DUPLEX CHANNEL ICON

Displayed when a Duplex channel is selected.

2 PANEL DESCRIPTION

12 CALL CHANNEL NUMBER

Displays the selected operating channel number.

- ① For the USA and Canada Channels, "A" is displayed when a simplex channel is selected.

13 SOFTWARE KEY FUNCTION DISPLAY

The functions of each keys are displayed.

See "Software keys" on the next page for details.

14 POSITION/TIME READOUTS

Readouts the current position and time when valid GPS data is received, or when manually entered.

- The letter after the time shows the source of the position data, I: internal, E: external, M: manual, L: local.

Received GPS data:

- "??" blinks if no GPS data is received for 30 seconds after receiving valid GPS data, and then "??" and a warning message are displayed alternately after 10 minutes.
- A warning message is displayed if no GPS data is received for 4 hours after receiving valid GPS data.
- "NO POS NO TIME" is displayed if no GPS data is received for 2 minutes after turning ON the transceiver, and then a warning message is displayed.

Manually entered GPS data:

- A manually entered GPS data is valid for 4 hours, and then a warning message is displayed after 4 hours.

15 SCAN INDICATOR

- "SCAN" or "SCAN 16" is displayed while scanning.
- "DW" or "TW" and watched channel number is displayed while using the Dualwatch or Tri-watch function.

■ Software keys

Various often-used functions are assigned to the software keys for easy access. The functions' icons are displayed above the software keys, as shown below.

◇ Using the software keys

Selecting a software key function

Push [◀] or [▶] to slide through the selectable functions that are assigned to the software keys.

Push the software key under the function's icon to select the function.

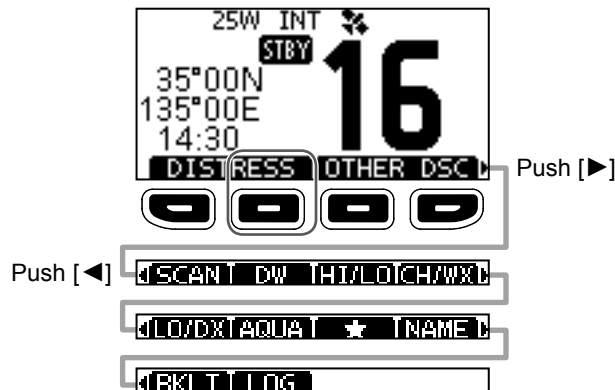

NOTE: The displayed icons or their order may differ, depending on the transceiver version or the presetting. Ask your dealer for details.

◇ **Software keys**

Distress Call **DISTRESS**

Push to display the “Distress” screen to select the nature of the call, then to make a call.

① **DTRS** is displayed in the Multiple-task mode (for only the USA version).

NEVER MAKE A DISTRESS CALL IF YOUR SHIP OR A PERSON IS NOT IN AN EMERGENCY. A DISTRESS CALL SHOULD BE MADE ONLY WHEN IMMEDIATE HELP IS NEEDED.

Other DSC **OTHER DSC**

Push to compose an Individual call, Group call, All Ships call or a Test call.

① **OTH** is displayed in the Multiple-task mode (for only the USA version).

Task **TASK** (For only the USA version) (p. ??)

Displayed only in the Multiple-task mode. Push to display the task list.

Scan **SCAN**

Push to start or stop a Normal or Priority scan.

Dualwatch/Tri-watch **DW/ TW**

Push to start or stop Dualwatch or Tri-watch.

High/Low **HI/LO**

Push to set the output power to high or low.

① Some channels are set to only low power.

Channel/Weather channel **CHWX**

Push to select regular channels or Weather channels.

① The Weather channel is for only the USA version.

CHAN is displayed for other versions.

① While the Call channel or Channel 16 is displayed, push this key to return to the regular channel mode.

Low **LODY** (For only the USA version)

Push to turn the Attenuator ON or OFF.

AquaQuake **AQUA**

Hold down to turn ON the AquaQuake function to clear water from the speaker grill.

Favorite channel **★**

- Push to select a Favorite channel.
- Hold down for 1 second to set/release the displayed channel as a Favorite channel.

Channel Name **NAME**

Push to edit the name of the displayed channel.

Backlight **BKLT**

Push to display the backlight brightness adjustment screen.

① While in the adjustment mode, push [**▲**]/[**▼**][**◀**]/[**▶**] or rotate [DIAL] to adjust the brightness to between 1 and 7, or OFF.

LOG **LOG**

Push to display the received call log or distress message log.

2 PANEL DESCRIPTION

■ Microphone

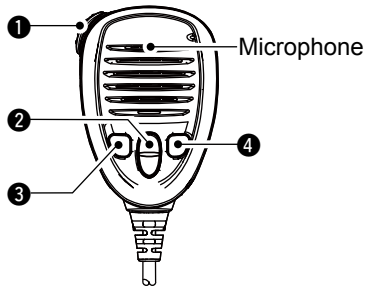

❶ PTT SWITCH [PTT]

Hold down to transmit, release to receive.

❷ UP/DOWN KEYS [▲]/[▼]

Push to change the channel.

- ❶ When the "FAV on MIC" item is set to "ON," you can select Favorite channels, change scanning direction or manually resume a scan.

❸ TRANSMIT POWER KEY [HI/LO]

- Push to set the power level to high or low.
- Some channels are set to only low power.
- While holding down this key, turn ON the transceiver to turn the Microphone Lock function ON or OFF.

❹ CHANNEL 16/CALL CHANNEL KEY [16/C]

- Push to select Channel 16.
- Hold down for 1 second to select the Call channel.
 - The "CALL" icon is displayed.

■ Entering the MMSI code

The Maritime Mobile Service Identity (MMSI: DSC self ID) code consists of 9 digits. You can only enter the code when turning ON the transceiver for the first time.

This initial code entry can be done only once. After entering, it can be changed only by your dealer or distributor. If your MMSI code has already been entered, this entry is not necessary.

1. Hold down [DIAL] for 1 second to turn ON the transceiver.
 - Three short beeps sound, and “Push [ENT] to Register your MMSI” is displayed.
2. Push [ENT] to start entering the MMSI code.
 - The “MMSI Input” screen is displayed.
 - ① Push [CLR] twice to skip the entry.
 - If you skip the entry, you cannot make a DSC call. To enter the code after skipping, turn OFF the power, and then turn it ON again.
3. Enter the MMSI code.

TIP:

- Select a number using [◀] and [▶].
- Push [ENT] to enter the selected number.
- Select “←” or “→,” or rotate [DIAL] to move the cursor.

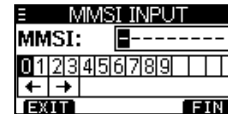

4. Repeat step 3 to enter all 9 digits.
5. Push **FIN** to set the entered code.
 - The “Confirmation” screen is displayed.
6. Enter your MMSI code again to confirm.

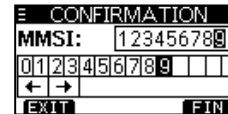

7. Push **FIN** to set the entered code.
 - When your MMSI code is successfully entered, “MMSI Successfully Registered” is briefly displayed, and then enters the operating screen.

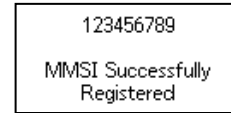
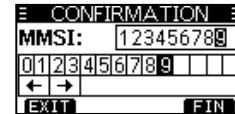

① Your MMSI code is also displayed on the operating screen.

NOTE: For Dutch and German versions, the ATIS ID is also required to be set. See the next page and set it.

3 PREPARATIONS

■ Entering the ATIS ID (For Dutch and German versions)

The Automatic Transmitter Identification System (ATIS) ID consists of 10 digits. You can enter the ID in the “ATIS ID Input” item on the Menu screen.

This ID entering can be done only once. After entering, it can be changed only by your dealer or distributor. If your ATIS ID has already been entered, this entry is not necessary.

1. Push [MENU].
 - The Menu screen is displayed.
2. Push [▲] or [▼], or rotate [DIAL] to select “ATIS ID Input,” then push [ENT] to start entering.
 - The “ATIS ID Input” screen is displayed.
3. Enter your ATIS ID.

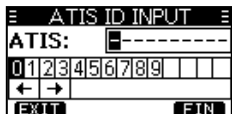

TIP:

- Select a number using [◀] and [▶].
- Push [ENT] to enter the selected number.
- Select “←” or “→,” or rotate [DIAL] to move the cursor.

4. Repeat step 3 to enter all 10 digits.
5. Push **FIN** to set the entered ID.
 - The “Confirmation” screen is displayed.
6. Enter your ATIS ID again to confirm.

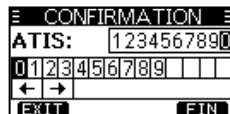

7. Push **FIN** to set the entered ID.
 - When your ATIS ID is successfully entered, the screen displays “ATIS ID Successfully Registered,” and then enters the operating screen.

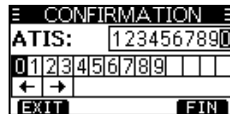

- ① You can check the ATIS ID in “Radio Info” on the Menu screen.

■ Selecting a channel

◇ Regular Channel

You can select a channel by pushing [▲] or [▼].

◇ Channel 16

Channel 16 is the distress and safety channel. It is used to establish the initial contact with a station and for emergency communications. Channel 16 is monitored during both Dualwatch and Tri-watch. While in the standby mode, you must monitor Channel 16.

- Push [16/C] to select Channel 16.

① To return to the previously selected channel, push the software key below [CHAN] or [CH/WX].

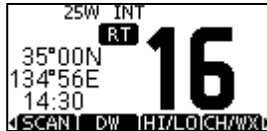

◇ Call channel

Each Channel Group has separate leisure-use Call channels. The Call channel is monitored during Tri-watch. The Call channels can be selected and used to store your most often used channel in each Channel Group, for quick recall.

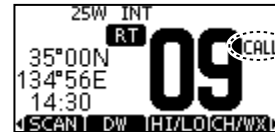

Hold down [16/C] for 1 second to select the Call channel.

- The Call channel number and “CALL” are displayed.

① To return to the previously selected channel, push **[CHAN]** or **[CH/WX]**.

4 BASIC OPERATION

◇ Selecting a Channel Group

Channel Groups are preset into your transceiver. You can select the Channel Group between USA, International, Canadian, DSC, and ATIS depending on the transceiver version.

Version	Preset Channel Group				
	USA	INT	CAN	DSC	ATIS
USA	✓	✓	✓		
UK	✓	✓			
European		✓			
Dutch		✓			✓
German		✓		✓	✓
Chinese	✓	✓	✓		
Australian	✓	✓			

1. Push [MENU].
 - The Menu screen is displayed.
2. Push [▲], [▼] or rotate [DIAL] to select “Radio Settings,” then push [ENT].
 - The “RADIO SETTINGS” screen is displayed.
3. Push [▲], [▼] or rotate [DIAL] to select “Channel Group,” then push [ENT].
 - The “CHANNEL GROUP” screen is displayed.
4. Push [▲], [▼] or rotate [DIAL] to select a Channel Group, and then push [ENT].
 - ① push [EXIT] to exit the Menu screen.
 - ① The selected Channel Group’s icon is displayed on the operating screen.

◇ Weather channels and Weather Alert

For the USA an Australian versions, the transceiver has 10 preset Weather channels. You can use these channels to monitor broadcasts from the National Oceanographic and Atmospheric Administration (NOAA). The transceiver automatically detects a Weather alert tone on the selected weather channel, or while scanning.

Selecting a Weather channel

1. Push [CHWX].
 - “WX” is displayed on the operating screen instead of the Channel Group icon.

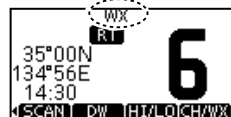

2. Push [▲] or [▼] to select a Weather channel.

Setting the Weather Alert

1. Push [MENU].
2. Push [▲], [▼], or rotate [DIAL] to select “Radio Settings,” and then push [ENT].
 - The “RADIO SETTINGS” screen is displayed.
3. Select “WX Alert,” and then push [ENT].
 - The “WX Alert” screen is displayed.



4. Select “On W/Scan” (On with scan) or “On.”
 - “” is displayed next to the weather channel icon.



■ Adjusting the volume level

- Rotate [DIAL] to adjust the audio volume level.

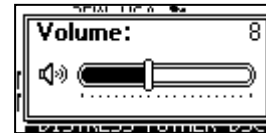

- ① If no key is pushed for 5 seconds, the screen automatically closes.

■ Adjusting the squelch level

Squelch enables the audio to be heard only while receiving a signal that is stronger than the set level. A higher level blocks weak signals, so that you can receive only stronger signals. A lower level enables you to hear weak signals.

1. Push [VOL/SQL] twice.
 - The squelch level adjustment screen is displayed.



2. Rotate [DIAL] to adjust the volume level.
 - ① If no key is pushed for 5 seconds, the adjustment screen automatically closes.

■ Adjusting the backlight or the display contrast

1. Display the “BACKLIGHT” or “CONTRAST” screen.

[MENU] > Configuration > **Backlight**

[MENU] > Configuration > **Display Contrast**

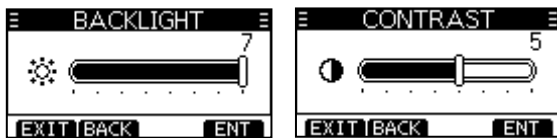

2. Push [▲], [▼], or rotate [DIAL] to Adjust, then push [ENT] to set.
① push **EXIT** to exit the Menu screen.

■ Setting the Call channel

By default, a Call channel is set in each Channel Group. You can set your most often-used channel as your Call channel in each Channel Group for a quick recall.

1. Display the “CALL CHANNEL” screen.

[MENU] > Radio Settings > **Call Channel**



2. Push [▲], [▼], or rotate [DIAL] to select the channel.
3. Push [ENT] to set the selected channel as the Call channel.
① Push **EXIT** to return to the operating screen.

■ Receiving and transmitting

CAUTION: Transmitting without an antenna may damage the transceiver.

1. Push [▲] or [▼] to select the channel to call.
 - ① You cannot transmit on Channel 70.
 - ① **BUSY** is displayed while receiving a signal.
 - ① You can also select the channel with [▲] or [▼] on the microphone. (only when the FAV on MIC is OFF (p. 53))
2. Hold down [PTT] on the microphone and speak into the microphone.
 - **TX** is displayed while transmitting.
3. Release [PTT] to receive.

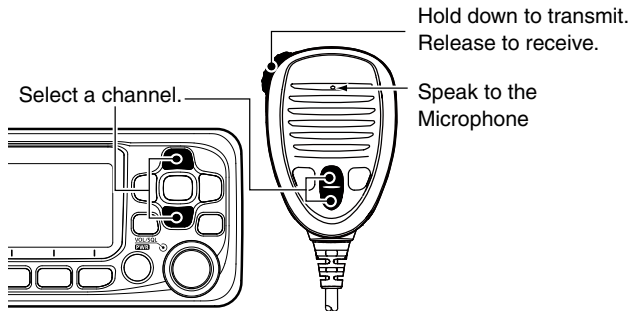

TIP: To maximize the readability of your transmitted signal, pause for a second after pushing [PTT] and hold the microphone 5 to 10 cm (2 to 4 inches) from your mouth, and then speak at your normal voice level.

NOTE:

- Except for the Export version, the Time-out Timer function cuts OFF transmission after 5 minutes of continuously transmitting, to prevent prolonged transmission.
- The Noise Cancel function reduces random noise components in the transmit and/or received signal.

■ Microphone Lock function

The Lock function electronically locks all keys [▲], [▼], [16/C], and [H/L] on the microphone to prevent accidental channel changes or functions access.

While holding down [HI/LO] on the microphone, hold down [PWR] (Dial) for 1 second to turn the Lock function ON or OFF.

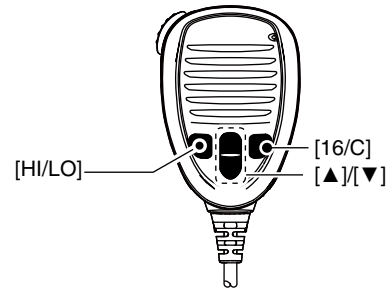

4 BASIC OPERATION

■ AquaQuake Water Draining function

Water in the speaker grill may muffle the sound coming from the speaker. The AquaQuake Water Draining function removes water from the speaker grill by vibrating the speaker.

1. Push [◀] or [▶] to select **AQUA**.
2. Hold down **AQUA** to turn ON the function.
 - A low frequency vibration beep sounds to drain the water, regardless of the volume level setting.



- ① This function is activated for a maximum of 10 seconds, even if you continue to hold down **AQUA**.
3. Release the key to turn OFF the function.

■ Editing a channel name

You can edit the name of each operating channel and weather channel, using numbers, uppercase letters, symbols, and a space. This enables easy recognition of the channels or stations. All VHF marine channels are set with default names.

1. Push [▲] or [▼] to select the channel to edit.
2. Push [◀] or [▶] to select **NAME**.
 - ① You cannot edit a channel name during Dualwatch, Tri-watch, or a Scan.
3. Push **NAME**.
 - The “Channel Name” screen is displayed.



4. Edit the channel name.

TIP:

- Select **!\$?** to enter characters, and select **123** to enter numbers and letters.
- Select characters or space using [▲]/[▼]/[◀]/[▶].
- Push [ENT] to enter the selected character.
- Select “←” or “→,” or rotate [DIAL] to move the cursor.
- Push **EXIT** to cancel editing.

5. Push [FIN] to set the edited name.

■ Scan types

You can find ongoing calls by scanning the Favorite channels.

Before starting a scan, you need to:

- Set the channels that you want to scan as Favorite channels. (p. 17)
 - ① Only the Favorite channels are scanned.
- Set the scan type to “Priority Scan” or “Normal Scan” on the “Radio Settings” screen. (p. 55)

Normal Scan

The Normal Scan sequentially searches through all Favorite channels. However, Channel 16 is not checked unless it is set as a Favorite channel.

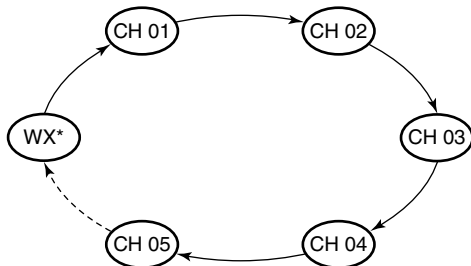

*For USA, Australian, and Export versions. When the Weather Alert function is ON, the previously selected Weather channel is also scanned.

Priority Scan

The Priority Scan sequentially searches through all Favorite channels, while also monitoring Channel 16.

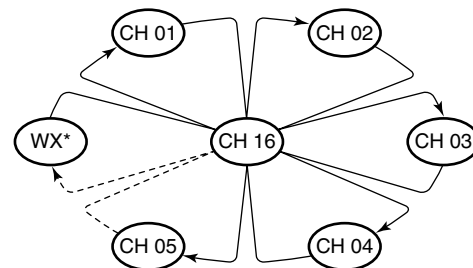

*For USA, Australian, and Export versions. When the Weather Alert function is ON, the previously selected Weather channel is also scanned.

When a signal is received:

On Channel 16

The scan pauses until the signal disappears.

On a channel other than Channel 16

The scan becomes Dualwatch until the signal disappears.

5 SCAN OPERATION (Except for the Dutch Version)

■ Setting Favorite channels

You can quickly recall often-used channels by setting them as Favorite channels. You can set Favorite channels in each Channel Group.

1. Select a Channel Group.
2. Push [▲] or [▼] to select the channel you want to set as a Favorite channel.
3. Push [◀] or [▶] to display .
4. Hold down **★** for 1 second.
 - The selected channel is set as a Favorite channel, and “★” is displayed.
 - ① To cancel the setting, **★** again for 1 second.

TIP: You can set all channels as Favorite channels, clear all settings, or reset to the default. By default, some channels are preset as Favorite channels. The preset channels differ, depending on the transceiver version.

■ Starting a scan

1. Select a Channel Group.
2. Push [◀] or [▶] to display **SCAN**.
3. Push **SCAN**.
 - The scan starts.
 - “**SCAN 16**” is displayed during a Priority Scan, and “**SCAN**” is displayed during a Normal Scan.
 - ① When a signal is received, the scan pauses until the signal disappears, or resumes after 5 seconds, depending on the Scan Timer setting in “Radio Settings.”
 - ① A beep sounds and “16” blinks when a signal is received on Channel 16 during a Priority scan.
4. To stop the scan, push **SCAN**.

TIP: In order to properly receive signals, be sure to adjust the squelch to a suitable level.

Example: Starting a Normal Scan

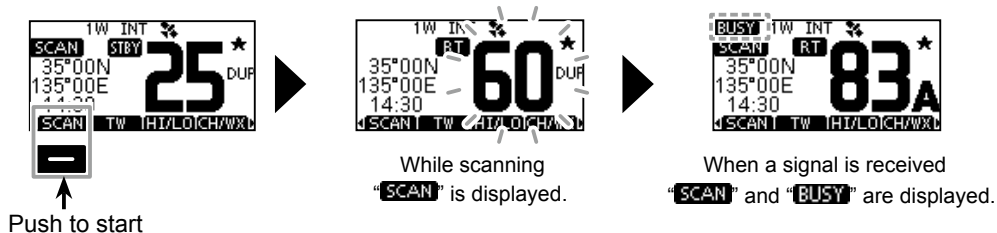

■ Description

Dualwatch and Tri-watch are convenient to monitor Channel 16 while you are operating on another channel.

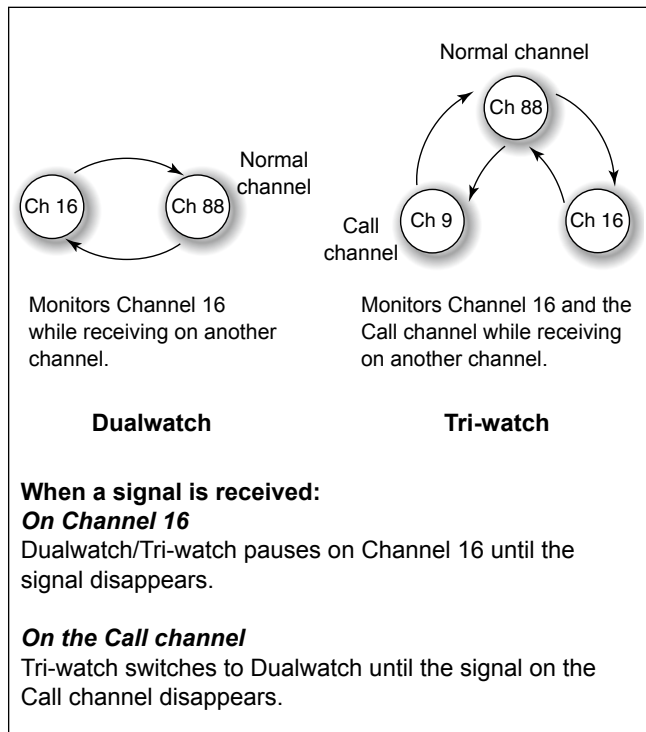

■ Operation

1. Select Dualwatch or Tri-watch in "Radio Settings" in the Menu screen.
2. Push [▲] or [▼] to select a channel.
3. Push [◀] or [▶] to display **DW** (Dualwatch) or **TW** (Tri-watch).
4. Push **DW** or **TW**.
 - Dualwatch or Tri-watch starts.
 - "**DW 16**" is displayed for Dualwatch, and "**TW 16**" is displayed for Tri-watch.
 - ① Beeps sound when a signal is received on Channel 16.
5. To cancel Dualwatch or Tri-watch, push **DW** or **TW** again.

Example: Operating Tri-watch on INT Channel 25.

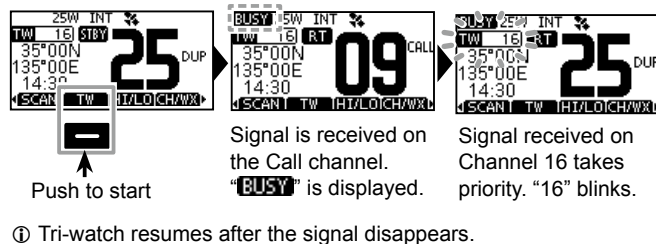

■ DSC address ID

◇ Entering an Individual ID

You can enter a total of 60 Individual IDs, and assign names of up to 10 characters.

1. Display the “INDIVIDUAL ID” screen.

[MENU] > DSC Settings > **Individual ID**

2. Push **ADD**.
 - “No ID” is displayed if no ID is entered.
2. Push **ADD**.
 - “The Individual ID” entry screen is displayed.

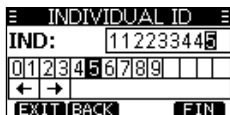

3. Enter the Individual ID.

TIP:

- Select a number using [◀] and [▶].
- Push [ENT] to enter the selected number.
- Select “←” or “→,” or rotate [DIAL] to move the cursor.

NOTE: the first digit is fixed as “0” for a Group ID. The first two digits are fixed as “00” for any Coast station ID.

4. Push **FIN** to start entering the name.



TIP:

- Push **!\$%** to use characters, and select **ABC** to use numbers and letters.



- Select characters or space using [▲]/[▼]/[◀]/[▶].
- Select “◀” or “▶” to scroll.
- Push [ENT] to enter the selected character.
- Select “←” or “→,” or rotate [DIAL] to move the cursor.

5. After entering, push **FIN** to save, and return to the previous screen.
 - The entered name is displayed.



◇ Entering a Group ID

You can enter a total of 30 Group IDs, and assign names of up to 10 characters.

1. Display the “GROUP ID” screen.

[MENU] > DSC Settings > **Group ID**

- “No ID” is displayed if no ID is entered.

2. Push **ADD**.
 - The Group ID’s entry screen is displayed.
3. Enter the Group ID and its name in the same way as described on the previous page.
4. After entering, push **FIN** to save, and return to the previous screen.
 - The entered name is displayed.

NOTE: The first digit is fixed as “0” for a Group ID. The first two digits are fixed as “00” for any Coast station ID.

◇ Deleting an entered ID

(Example: Deleting an Individual ID: ICOM 2)

1. Display the “INDIVIDUAL ID” screen.

[MENU] > DSC Settings > **Individual ID**

2. Push [▲] or [▼] to select “ICOM 2.”

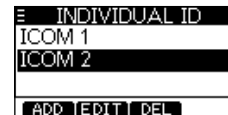

3. Push **DEL**.
 - “Are You Sure?” is displayed.
4. Push **OK** to delete.
 - ① Push **CANCEL** to cancel the deletion.
 - The selected ID is deleted, and then returns to the previous screen.

TIP: You can edit an ID and its name by pushing **EDIT** in step 3.

■ Entering the position and time

A Distress call should include the vessel's position and time. If no GPS data is received, manually enter the position and Universal Time Coordinated (UTC) time.

NOTE:

- The manual entry is disabled while the GPS data is received.
- The manually entered position and time is valid only for 4 hours, or until turning OFF the transceiver.

1. Display the "POSITION INPUT" screen.

[MENU] > DSC Settings > **Position Input**

2. Enter the latitude.

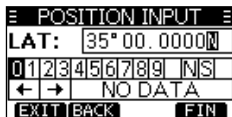

TIP:

- Select a number or a compass direction using [▲]/[▼]/[◀]/[▶].
- Select "←" or "→," or rotate [DIAL] to move the cursor.
- Push [ENT] or **FIN** to enter the selected number.

3. Enter the longitude and the UTC time.

① See the TIP in step 2 to enter.



4. Push **FIN** to set the entered position and time.
5. Push **EXIT** to return to the standby screen.



① The entered position and time are displayed on the operating screen.

① "M" (manual) is displayed next to the time display.

■ Sending DSC calls (Distress)

A Distress call should be sent if, in the opinion of the Master, the ship or a person is in distress and requires immediate assistance.

NEVER MAKE A DISTRESS CALL IF YOUR SHIP OR A PERSON IS NOT IN AN EMERGENCY. A DISTRESS CALL SHOULD BE MADE ONLY WHEN IMMEDIATE HELP IS NEEDED.

◇ Simple call

1. Confirm that no Distress call is being received.
2. While lifting up the key cover, hold down [DISTRESS] for 3 seconds until you hear 3 short countdown beeps and a long beep sound.
 - The backlight blinks.

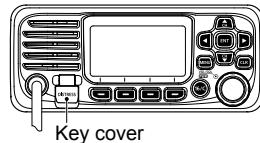

3. After sending, wait for an Acknowledgement call.
 - “Waiting for ACK” is displayed.



- ① The Distress call is automatically sent every 3.5 to 4.5 minutes, until an Acknowledgement is received, or a Distress Cancel call is sent.

- ① When you receive an Acknowledgement, alarm sounds.
4. Push any software key to turn OFF the alarm.
 - Channel 16 is automatically selected.



5. Hold down [PTT] to explain your situation.
6. Push **CANCEL** to return to the operating screen.

TIP: A default Distress alert contains:

- Nature of distress: Undesignated distress
- Position information: The latest GPS, or manually input position, which is held for 23.5 hours or until turning OFF the transceiver.

NOTE on Distress calls (Simple calls and Regular calls):

If no valid position data is received when sending a Distress call, the transceiver waits for 15 seconds until position data is received, and then the Distress call is sent. If no position is received during this 15 seconds, the position data in the transceiver memory is automatically sent. However, if there is no position data in the memory, the Distress call is sent without position data.

7 DSC OPERATION

◇ Regular call

Select the nature of the Distress call to include in the Regular Distress call.

1. Push **DISTRESS**.
 - The Distress Call screen is displayed.
2. Push [ENT] to enter the Nature selection mode.
3. Push [▲], [▼], or rotate [DIAL] to select the nature of the call, then push [ENT]. (Example: Flooding)
 - The confirmation screen is displayed.
 - ① If no valid GPS data is being received, push [▲], [▼], or rotate [DIAL] to select "Position," then enter the latitude, longitude, and UTC.
 - ① See "Entering the position and time" for details."
4. While lifting up the key cover, hold down [DISTRESS] (the red button) for 3 seconds until you hear 3 short countdown beeps and a long beep sound.
 - The backlight blinks.

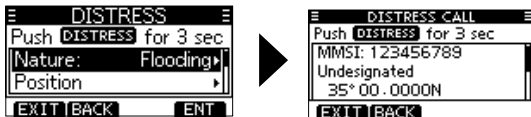

5. After sending, wait for an Acknowledgement call.
 - "Waiting for ACK" is displayed.



- ① The Distress call is automatically sent every 3.5 to 4.5 minutes, until an Acknowledgement is received, or a Distress Cancel call is sent.
 - ① When an Acknowledgement is received, an alarm sounds.
6. Push any software key to turn OFF the alarm.
 - Channel 16 is automatically selected.
 7. Hold down [PTT] to communicate.

TIP: You can also send a Regular call by selecting the "Compose Distress" item on the Menu screen.

NOTE (For USA and Export versions):*After sending a Distress call without position data*

- While waiting for an Acknowledgement, if valid position data is received, the transceiver will automatically send a Distress call again.
- Even after exiting the DSC mode, if valid position data is received within 20 minutes after receiving a Distress Acknowledgement, the transceiver will automatically send a Distress call again.

◇ Distress call software key description**While waiting for an Acknowledgement:**

- [CANCEL]:** Cancels the Distress call and enables you to send a Cancel call. (See the right column)
- [RESEND]:** Enables you to resend the Distress call by holding down [DISTRESS] again.
- [PAUSE]:** Pauses the countdown to resend the next Distress call.
- [INFO]:** Displays the information of the Distress call that you have sent.

After receiving an Acknowledgement:

- [EXIT]:** Closes the Distress operation, and returns to the operating screen.
- [HIST]:** Displays the “Distress History.”
- [INFO]:** Displays the information of the received Distress Acknowledgement.

◇ Distress Cancel call

If you have accidentally made a Distress call, or made an incorrect Distress call, send a Distress Cancel call to cancel the call as soon as possible while waiting for an Acknowledgement call, and report the purpose of the cancellation.

1. While waiting for an Acknowledgement call, push **CANCEL**.
 - The screen below is displayed.
2. Push **CONTINUE**.
 - The Distress Cancel call is sent.
 - Channel 16 is automatically selected.
3. Hold down [PTT] to report the purpose of the cancellation.
 - ① You can display the wording of the cancellation by pushing [▼].
4. After communicating, push **FINISH**.
 - The screen to the right is displayed.
5. Push **OK** to finish the Distress Cancel call.
 - Returns to the operating screen.

■ DSC Settings

On the “DSC Settings” screen, you can make settings on the DSC call related items.

Position Input

See “*Entering the position and time*” for details.

Individual ID

See “*Entering an Individual ID*” for details.

Group ID

See “*Entering a Group ID*” for details.

Auto ACK

The Auto ACK function automatically sends an Acknowledgement call when the following calls are received.

- Individual call (Default: Differs depending on the version)
- Position Request call (Default: Manual)
- Polling Request call (Default: Auto)
- Test call (Default: Auto)

Manual: Manually send an Acknowledgement call.

Auto: Automatically send an Acknowledgement call.

TIP: When “Auto” is set to the Individual call, the Acknowledgement “Unable to Comply” is automatically sent when the call is received.

CH Auto Switch (Default: Accept)

Select whether or not to automatically switch to channel 16 or the specified channel, or select whether to switch or ignore the call.

Accept: After receiving a DSC call, the transceiver remains on the operating channel for 10 seconds. After that, the transceiver automatically switches to the channel that is specified on the DSC call.

Ignore: After receiving a DSC call, if you do not push the software key below [ACPT] in 10 seconds, the transceiver ignores the call, and then remains on the current operating channel.

Manual: After receiving a DSC call, you can select whether or not to accept the received DSC call.

■ DSC Settings (Continued)

DSC Data Output (Default: Off)

Select an option for the DSC Data Output function.

When receiving a DSC call, this function makes the transceiver send the call from its NMEA 0183 Output port to an external device.

① You can send Distress calls despite of this setting.

OFF: Does not send any call from the NMEA 0183 Output port.

All Stations: Sends the call from any vessel.

Stations List: Sends the call from any vessel on the DSC individual and group lists.

Alarm Status

Set the alarm ON or OFF for each DSC related item.

• **Safety** (Default: On)

An alarm sounds when a Safety DSC call is received.

• **Routine** (Default: On)

An alarm sounds when a Routine DSC call is received.

• **Warning** (Default: On)

An alarm sounds when:

- no MMSI code is entered.
- the position data has not been received for 2 minutes after turning ON the transceiver.

- the received position data has not been updated for 10 minutes.

- the received position data or manually entered position data has not been updated for 4 hours.

• **Self-Terminate** (Default: On)

An alarm sounds when duplicate Distress calls are received.

• **Discrete** (Default: On)

An alarm sounds when a lower priority call is received while receiving a high priority call.

CH 70 SQL Level (Default: 5)

Adjust the Squelch level for Channel 70 to between 1 and 10, or Open.

① "**BUSY**" is displayed when adjusted to Open.

A higher level blocks weak signals, which enables you to send a DSC call.

7 DSC OPERATION

Self- Test

The Self-Test sends DSC signals to the receiving AF circuit to compare the sending and receiving signals at the AF level.

- Push [ENT] to start the Self Test.
- ① When the sending and receiving DSC signals match, "OK" is displayed.

Procedure (Default: Single)

(For only the USA version, depending on the presetting.)
You can select the type of task for the transceiver.

Single: Handles only 1 task at the same time.

Multiple: Handles up to 7 tasks at the same time. You can make one or more than 2 DSC calls in parallel.

■ Using the Menu screen

The Menu screen is used to set items, select options, and so on for the transceiver's functions.

◇ Using the Menu screen

Example: Setting the channel group to "INT."

1. Push [MENU].
 - The Menu screen is displayed.

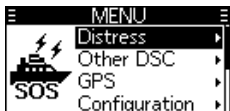

2. Push [▲], [▼], or rotate [DIAL] to select "Radio Settings," and then push [ENT].
 - The "Radio Settings" screen is displayed.
- ① Holding down [▲] or [▼] sequentially scrolls up or down through the Menu screen.



3. Push [▲], [▼], or rotate [DIAL] to select "Channel Group," then push [ENT].
 - The "CHANNEL GROUP" screen is displayed.



4. Push [▲], [▼], or rotate [DIAL] to select "INT," then push [ENT].
 - ① "INT" is set and the transceiver returns to the previous screen.



TIP:

- ① To exit the Menu screen, push **EXIT** or [MENU].
- ① To return to the previous screen, push **BACK** or [CLR].

8 MENU SCREEN

◇ Menu screen items

The Menu screen contains the following items.
See the referred pages for each items.

Distress (Chapter 7)

Item	Item
Undesignated	Sinking
Fire,Explosion	Adrift
Flooding	Abandoning Ship
Collision	Piracy
Grounding	Man Overboard
Capsizing	—

Other DSC (Chapter 7)

Item	Item
Type	Mode
Address	Channel
Category	

GPS

Configuration

Item	Item
Backlight	UTC Offset
Display Contrast	Inactivity Timer
Key Beep	GPS*
Key Assignment	—

DSC Log (Chapter 7)

Item	Item
Received	Transmitted

Radio Settings

Item	Item
Scan Type*	WX Alert*
Scan Timer*	FAV Settings
Dual/Tri-watch*	FAV On MIC
Channel Group	CH Display*
Call Channel	CH Close-up

DSC Settings

Item	Item
Position Input	Data Output
Individual ID	Alarm Status
Group ID	CH 70 SQL Level
Auto ACK	Self-Test
CH Auto Switch	Procedure

Radio Info

*May not be displayed, depending on the transceiver version.

■ Menu items description

◇ Configuration

Backlight (Default: 7)

You can adjust the backlight brightness between 1 and 7, or OFF.

Display Contrast (Default: 4)

You can adjust the display contrast level between 1 (lowest) and 7 (highest).

Key Beep (Default: On)

You can select whether or not to sound a beep when a key is pushed.

- **On:** Sounds a beep when a key is pushed.
- **Off:** No beep sounds, for silent operation.

Key Assignment

Softkey 1~16

You can change which software key functions to display, and their order. You can assign up to 16 software keys at a time.

- ① The usable software key functions and their order may differ, depending on the transceiver version or presetting.

Set Default

Sets the software key function order as default.

- ① The default setting may differ, depending on the transceiver version or presetting.

UTC Offset (Default: 00:00)

Set the offset time between Universal Time Coordinated (UTC) and your local time to between -14:00 and +14:00 (in 1 minute steps).

Inactivity Timer

The transceiver automatically returns to the operation screen if you push no key for the set period of time for each mode.

Not DSC (Default: 10 min)

Setting for when a screen that is not related to DSC is displayed.

DSC (Default: 15 min)

Setting for when a screen that is related to DSC is displayed.

Distress (Default: Off)

Setting for when a screen that is related to a Distress call is displayed.

RT (Default: 30 sec)

Setting for when the transceiver is in the Radio Telephone mode.

GPS

Selects a satellite to be used for GPS (Global Positioning System) to pinpoint the geographic location of your transceiver anywhere in the world.

① This setting may not be usable, depending on the transceiver version or presetting.

GPS (Always: On)

The GPS (Global Positioning System) is permanently set to ON.

GLONASS (Default: On)

Turns the GLONASS (GLObal'naya NAVigatsionnaya Sputnikovaya Sistema) function ON or OFF.

SBAS (Default: Off)

Turns the SBAS (Satellite Based Augmentation System) function ON or OFF.

The SBAS transmits signals to correct errors, and improves accuracy and reliability in data received from regular GNSS satellites. When this function is ON, you can use the corrected data.

◇ Radio Settings

Scan Type (Default: —)

The transceiver has 2 scan types. Select Normal Scan and Priority Scan.

- **Normal Scan:** Scans all Favorite channels in the selected channel group.
- **Priority Scan:** Sequentially scans all Favorite channels, while monitoring Channel 16.

① The default setting differs, depending on the transceiver version.

Scan Timer (Default: Off)

You can use the Scan Timer to pause, or to resume after 5 seconds, when a signal is detected.

- **On:** When a signal is detected on a channel, the scan pauses for 5 seconds, and then resumes. If the signal disappears in less than 5 seconds, the scan immediately resumes.
- **Off:** When a signal is detected on a channel, the scan pauses until the signal disappears, and then resumes.

Dual/Tri-watch (Default: Dualwatch)

Select Dualwatch or Tri-watch.

- **Dualwatch:** Monitors Channel 16 while receiving on another channel.
- **Tri-watch:** Monitors Channel 16 and the Call channel while receiving on another channel.

Channel Group



Select the suitable channel group for your operating area. Select INT, USA, CAN, DSC, or ATIS depending on the transceiver version.

Call Chancel

You can change your Call channel. The default setting differs, depending on the transceiver version.

WX Alert (Default: Off)

For the USA and Australian versions, an NOAA broadcast station transmits a Weather Alert tone before any important weather information.

- ① “WX ” is displayed instead of “WX.”
- ① “WX ” blinks until you push a key after detecting an alert.
- **On W/ SC:** The preset Weather channels are sequentially checked while scanning.
- **On:** The previously selected (last used) Weather channel is checked while scanning.
- **Off:** The Weather Alert tone is not detected.

FAV Settings

You can set all channels as Favorite channels, clear all settings, or reset to default. By default, some channels are preset. The Favorite channels differ, depending on the transceiver version.

- **Set All Channels:** Sets all channels as Favorite channels.
- **Clear All Channels:** Clears all Favorite channels.
- **Set Default:** Resets Favorite channels to the default.

FAV on MIC (Default: Off)

You can select the channel set when you push [**▲**] or [**▼**] on the supplied microphone.

- **On:** Scrolls through only the Favorite channels.
- **Off:** Scrolls through all the channels.

8 MENU SCREEN

CH Display

You can select the number of digits to display the channel number.

- **3 Digits:** The channel number is displayed in 3 digits such as “01A.”
- **4 Digits:** The channel number is displayed in 4 digits such as “1001.”

① This setting may not be usable, depending on the transceiver version or presetting.

CH Close-up

You can select whether or not to display the channel name when changing the operating channel.

- **On:** The channel number and the channel name are briefly displayed when changing the channel.
- **Off:** The channel name is not displayed on the screen.

◇ Radio Info

Displays your transceiver's MMSI, Software version, and GPS version if built-in.



■ Connections

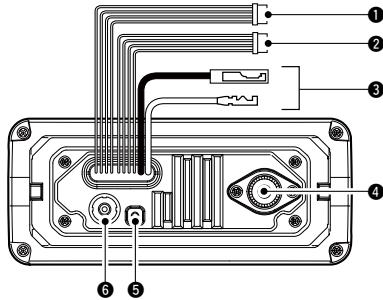

❶ NMEA IN/OUT LEADS

Brown: Talker B (Data-L), Data Out (-)

White: Talker A (Data-H), Data Out (+)

Connects to NMEA 0183 In lines of navigation equipment, to receive position data from other ships.

- An NMEA 0183 (ver. 2.0 or later) sentence format DSC or DSE compatible navigation equipment is required.
- The built-in GPS outputs RMC, GSA, GSV format sentences.

Green: Listener B (Data-L), GPS In (-)

Yellow: Listener A (Data-H), GPS In (+)

Connects to NMEA Out lines of a GPS receiver for position data.

- NMEA 0183 (ver. 2.0 or later) sentence format RMC, GGA, GNS, or GLL and VTG compatible GPS receiver is required. Ask your dealer about suitable GPS receivers.
- The GPS sentences input from an external GPS receiver have priority over the sentences from the built-in GPS.

❷ AF OUT LEADS

Blue: External Speaker (+)

Black: External Speaker (-)

Connects to an external speaker.

Orange: Data line

Gray: Data line

Used only for maintenance purpose.

NOTE for NMEA In/Out and AF Out leads:

The connectors are attached to keep the leads together. Before connecting to a piece of equipment, cut the leads to remove the connector.

❸ DC POWER CONNECTOR

Connects to a 13.8 V DC power source.

(+: Red, -: Black)

CAUTION: After connecting the DC power cable, NMEA leads or external speaker leads cover the connector and leads with a vulcanizing tape, as shown below, to prevent water seeping into the connection.

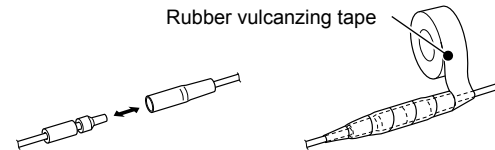

9 CONNECTIONS AND MAINTENANCE

4 ANTENNA CONNECTOR

Connects to a marine VHF antenna with a PL-259 connector.

CAUTION: Transmitting without an antenna may damage the transceiver.

5 GROUND TERMINAL

Connects to a vessel ground to prevent electrical shocks and interference from other equipment occurring. Use a PH M3 × 6 screw (user supplied).

◇ Connecting the MA-500TR

Connect the transceiver to the high-density D-Sub 15-pin connector of the MA-500TR using the OPC-2014* cable. After connecting, you can send an Individual DSC call to an AIS target using the transponder without entering the target's MMSI code.

* The OPC-2014 is supplied with the MA-500TR

- **Listener A (Data-H) lead (Yellow):**
Connects to lead 3 of the OPC-2014.
- **Listener B (Data-L) lead (Green):**
Connects to lead 2 of the OPC-2014.
- **Talker A (Data-H) lead (White):**
Connects to lead 5 of the OPC-2014.
- **Talker B (Data-L) lead (Brown):**
Connects to lead 4 of the OPC-2014.

■ Antenna

A key element in the performance of any communication system is the antenna. Ask your dealer about antennas and the best place to mount them.

■ Fuse replacement

One fuse is installed in the supplied DC power cable. If the fuse blows or the transceiver stops functioning, track down the source of the problem, repair it, and replace the damaged fuse with a new one of the proper rating. Fuse rating: 10 A

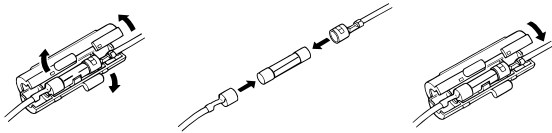

■ Cleaning

If the transceiver becomes dusty or dirty, wipe it clean with a soft, dry cloth.



DO NOT use harsh solvents such as Benzine or alcohol, as they will damage the transceiver's surfaces.

■ Supplied accessories

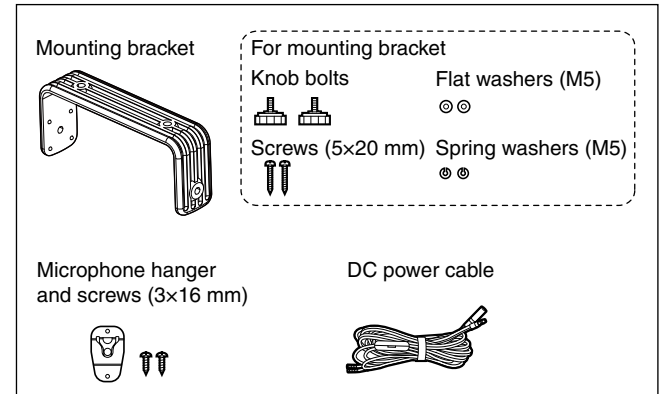

■ Mounting the transceiver

◇ Using the supplied mounting bracket

You can mount the transceiver on a dashboard using the universal mounting bracket supplied with your transceiver.

1. Mount the bracket securely to a surface that is more than 10 mm thick and can support more than 5 kg using the 2 supplied screws (5 × 20 mm).
2. Attach the transceiver to the bracket so that the face of the transceiver is at 90° to your line of sight when operating it.

CAUTION: KEEP the transceiver and microphone at least 1 m (3.3 ft) away from the vessel's magnetic navigation compass.

NOTE: Check the installation angle. The function display may not be easy to read at some angles.

NOTE for the IC-M330G and IC-M330GE:

Built-in GPS receiver is located at the right top of the front panel.

If the transceiver is covered with any object that interrupts the GPS signals from the satellites, the GPS receiver will not calculate its position.

Therefore, when you use the built-in GPS receiver, be sure the transceiver is positioned so the GPS receiver has a clear view to receive signals from satellites.

Mounting Example

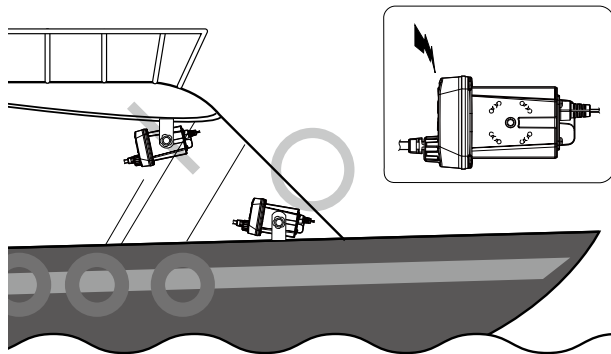
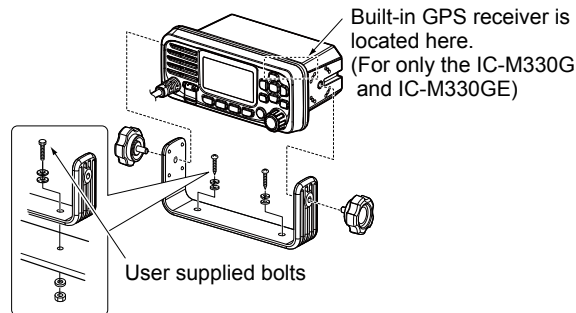

■ MBF-5 installation

An optional MBF-5 FLUSH MOUNT KIT is available for mounting the transceiver to a flat surface (less than 20 mm thick), such as an instrument panel.

KEEP the transceiver and microphone at least 1 meter away from your vessel's magnetic navigation compass.

1. Using the template on [page ??](#), carefully cut a hole into the instrument panel, or wherever you plan to mount the transceiver.
2. Attach the 2 bolts supplied with the MBF-5 on both sides of the transceiver.
3. Slide the transceiver through the hole, as shown below.

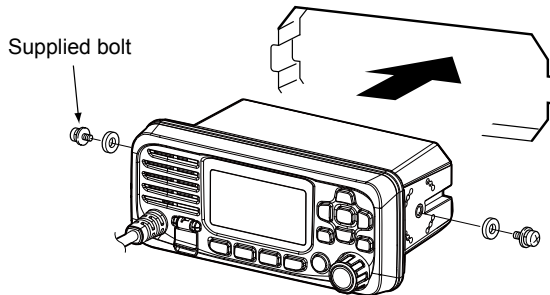

4. Attach the clamps on both sides of the transceiver.
 - ① Make sure that the clamps align parallel to the transceiver body.

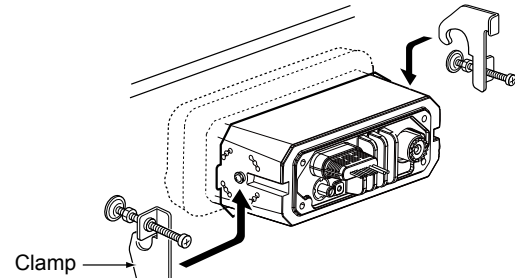

5. Tighten the end bolts on the clamps (rotate clockwise) so that the clamps press firmly against the inside of the instrument control panel. (Torque: 0.6 N•m)
6. Tighten the locking nuts (rotate counterclockwise) so that the transceiver is securely mounted in position, as shown below.
7. Connect the antenna and power cable, then return the instrument control panel to its original place.

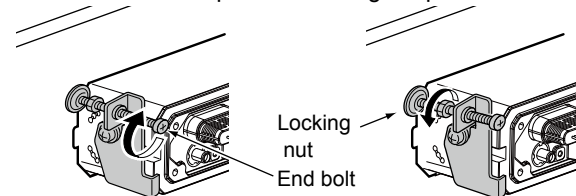

10 SPECIFICATIONS AND OPTIONS

■ Specifications

◇ General

- Frequency coverage:
 - TX IC-M330/IC-M330G 156.025 ~ 157.425 MHz
 - IC-M330E/IC-M330GE 156.025 ~ 161.425 MHz
(Depending on the version)
 - RX IC-M330/IC-M330G 156.050 ~ 163.275 MHz
 - IC-M330E/IC-M330GE 156.050 ~ 161.600 MHz
(Depending on the version)
 - CH70 156.525 MHz
- Mode: 16K0G3E (FM)
16K0G2B (DSC)
- Channel spacing: 25 kHz
- Operating temperature range: -20°C to +60°C;
-4°F to +140°F
- Current drain (at 13.8 V):
 - TX high (25 W) 5 A maximum
 - Maximum audio 1 A maximum
- Power supply requirement: 13.8V DC (10.8 ~ 15.9V)
- Frequency stability: ±5 ppm
- Antenna impedance: 50 Ω nominal
- Dimensions (approximately)
(projections not included): 156.5 (W) × 66.5 (H) × 110.1 (D) mm,
6.2 (W) × 2.6 (H) × 4.3 (D) in
- Weight (approximately): 730 g, 1.61 lb

◇ Transmitter

- Output power: 25 W or 1 W
- Modulation system: Variable reactance frequency modulation
- Maximum frequency deviation: ±5 kHz

- Spurious emissions:
 - IC-M330/IC-M330G Less than -70 dBc (High power)
Less than -56 dBc (Low power)
 - IC-M330E/IC-M330GE Less than 0.25 μW

◇ Receiver

- Receive system: Double conversion superheterodyne
- Sensitivity:
 - FM IC-M330/IC-M330G -120 dBm (typical) (12 dB SINAD)
 - IC-M330E/IC-M330GE -118 dBm (typical) (20 dB SINAD CCITT)
- DSC (CH70)
 - IC-M330/IC-M330G -5 dBμ emf (typical) (1% BER)
 - IC-M330E/IC-M330GE -4 dBμ emf (typical) (1% BER)
- Squelch sensitivity:
 - IC-M330/IC-M330G Less than -10 dBμ
 - IC-M330E/IC-M330GE Less than -2 dBμ emf
- Intermodulation rejection ratio:
 - FM IC-M330/IC-M330G More than 70 dB
 - IC-M330E/IC-M330GE More than 68 dB
- DSC (CH70) More than 73 dBμ emf (1% BER)
- Spurious response rejection ratio:
 - FM More than 70 dB
 - DSC (CH70) More than 73 dBμ emf (1% BER)
- Adjacent channel selectivity:
 - FM More than 70 dB
 - DSC (CH70) More than 73 dBμ emf (1% BER)
- Audio output power:
 - Internal 2 W
 - External 4.5 W at 10% distortion into a 4Ω load

All stated specifications are subject to change without notice or obligation.

◇ Dimensions

Unit: mm (inch)

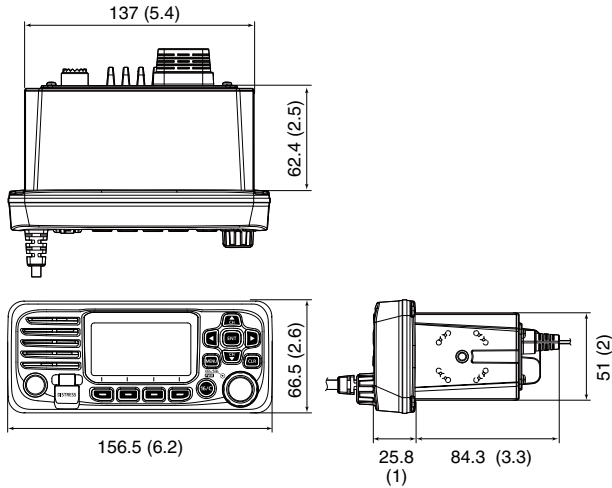

■ Options

- **MBF-5** FLUSH MOUNT KIT
To mount the transceiver to a panel.
- **MA-500TR** CLASS B AIS TRANSPONDER
To transmit individual DSC calls to a selected AIS target.

Count on us!

A7420-1EX
Printed in Japan
© 2017 Icom Inc.

Icom Inc.
1-1-32 Kamiminami, Hirano-ku, Osaka 547-0003, Japan