

INSTALLATION INSTRUCTIONS

Fan Coils

FEM, FSM, FSU

These instructions must be read and understood completely before attempting installation.

Safety Labeling and Signal Words

DANGER, WARNING, CAUTION, and NOTE

The signal words **DANGER**, **WARNING**, **CAUTION**, and **NOTE** are used to identify levels of hazard seriousness. The signal word **DANGER** is only used on product labels to signify an immediate hazard. The signal words **WARNING**, **CAUTION**, and **NOTE** will be used on product labels and throughout this manual and other manuals that may apply to the product.

DANGER - Immediate hazards which **will** result in severe personal injury or death.

WARNING - Hazards or unsafe practices which **could** result in severe personal injury or death.

CAUTION - Hazards or unsafe practices which **may** result in minor personal injury or product or property damage.

NOTE - Used to highlight suggestions which **will** result in enhanced installation, reliability, or operation.

Signal Words in Manuals

The signal word **WARNING** is used throughout this manual in the following manner:



The signal word **CAUTION** is used throughout this manual in the following manner:



Signal Words on Product Labeling

Signal words are used in combination with colors and/or pictures on product labels.

TABLE OF CONTENTS

Introduction	2
Location	2
Heater Packages	3
Position Unit	3 - 7
Air Ducts	7
Electrical Connections	7 - 11
Refrigerant Tubing	11
Refrigerant Metering Device	11
Condensate Drains	12
Accessories	13
Sequence of Operation	14
Start-up Procedure	14
Care and Maintenance	14
R-410A Quick Reference Guide	15

DEATH, PERSONAL INJURY, AND/OR PROPERTY DAMAGE HAZARD

Failure to carefully read and follow this warning could result in equipment malfunction, property damage, personal injury and/or death.

Installation or repairs made by unqualified persons could result in equipment malfunction, property damage, personal injury and/or death.

The information contained in this manual is intended for use by a qualified service technician familiar with safety procedures and equipped with the proper tools and test instruments.

Installation must conform with local building codes and with the National Electrical Code NFPA70 current edition.

INTRODUCTION

Models FEM and FSM are designed for maximum flexibility and can be used for upflow, horizontal left or right, and downflow applications (accessory kit required for downflow or horizontal right).

Model FSU is designed for upflow installation, and can be field modified for downflow and horizontal left or right applications (accessory kits required for downflow or horizontal).

All models are available for system sizes 1½ - 5 tons (18,000 - 60,000 BTUH) nominal cooling capacity.

All models have a factory installed and appropriately sized hard shut-off TXV metering device. FEM2, FSM2 and FSU2 are for R-22 refrigerant ONLY. FEM4, FSM4 and FSU4 are for R-410A refrigerant ONLY.

Factory approved electric heater packages are available in sizes 3kW through 30kW. See Product Specification literature for available accessory kits.

LOCATION

Select the best position which suits the installation site conditions. The location should provide adequate structural support, space in the front of the unit for service access, clearance for return air and supply duct connections, space for refrigerant piping connections and condensate drain line connections. If heaters are being installed make sure adequate clearance is maintained from supply duct work. **See Clearances in Figure 1.**

If the unit is located in an area of high humidity, nuisance sweating of casing may occur. On these installations a wrap of 2" fiberglass insulation with a vapor barrier is recommended.

NOTE: Internal filter can be accessed from separate filter door. If the filter can **NOT** be easily accessed, a remote

filter is recommended. Refer to ACCA Manual D for remote filter sizing.

⚠ WARNING

FIRE HAZARD

Failure to maintain proper clearances could result in personal injury, death, and/or property damage.

When heaters are installed, maintain clearances from combustible materials as specified on unit rating plate. Do not use plastic lined or combustible flexible ducting within 36 inches of the supply end of the fan coil.

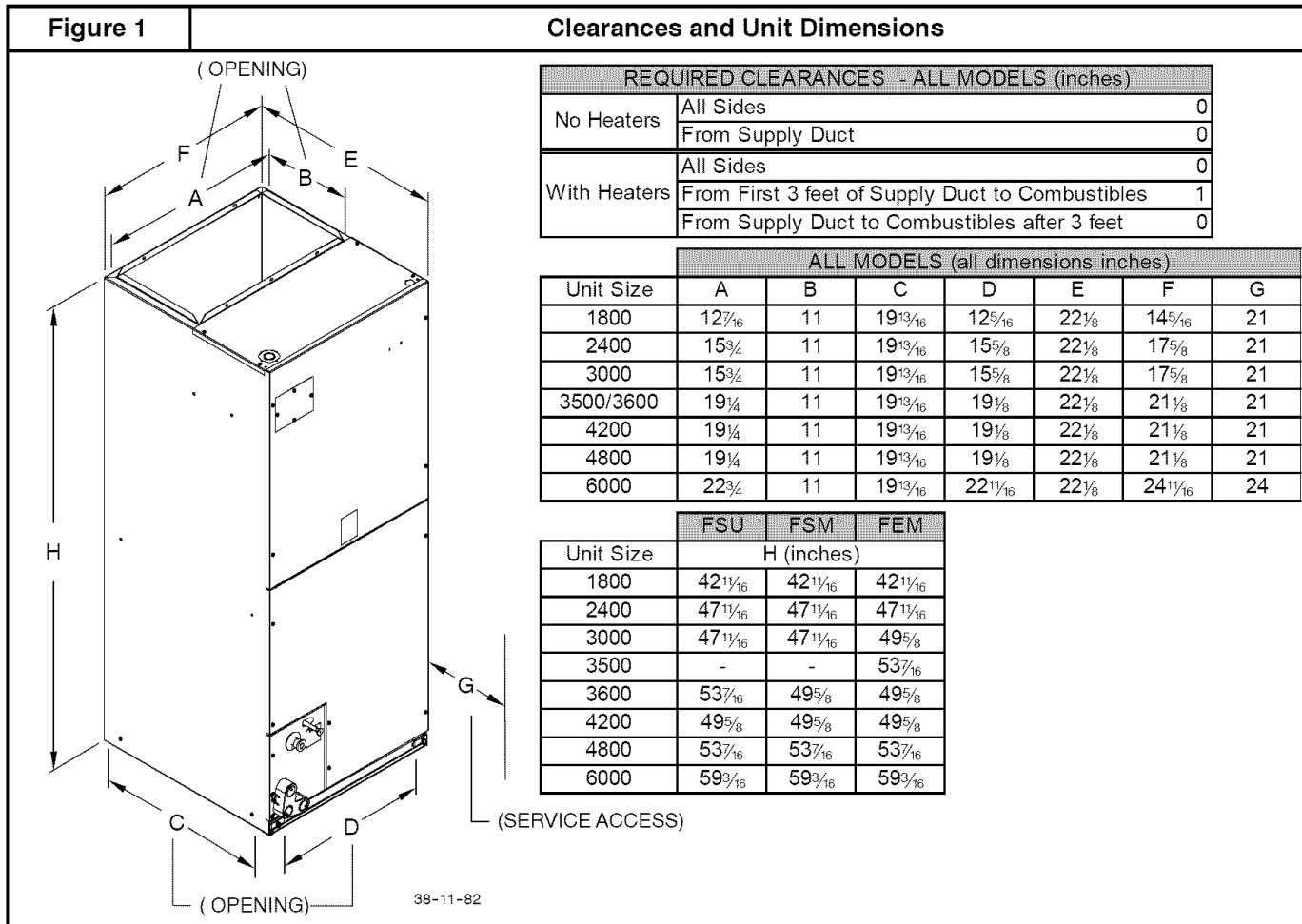

HEATER PACKAGES

Factory approved, field installed, UL listed heater packages are available from the equipment supplier. See unit rating plate for a list of factory approved heaters. Heaters

that are not factory approved could cause damage which would not be covered under the equipment warranty.

POSITION UNIT

Unit can stand or lie on floor, or hang from ceiling or wall. Allow space for wiring, piping, and servicing unit.

⚠ CAUTION

PROPERTY DAMAGE HAZARD

Failure to follow this caution may result in property damage

A field fabricated auxiliary drain pan, with a separate drain is REQUIRED for all installations over a finished living space or in any area that may be damaged by overflow from a restricted main drain pan. In some localities, local codes require an auxiliary drain pan for ANY horizontal installation.

A. UPFLOW INSTALLATION

If return air is to be ducted through a floor, set unit on floor over opening and use 1/8 to 1/4 inch thick fireproof resilient gasket between duct, unit, and floor.

Side return is a field option on slope coil models. Cut opening per dimensions shown in Figure 2. A field-supplied bottom closure is required.

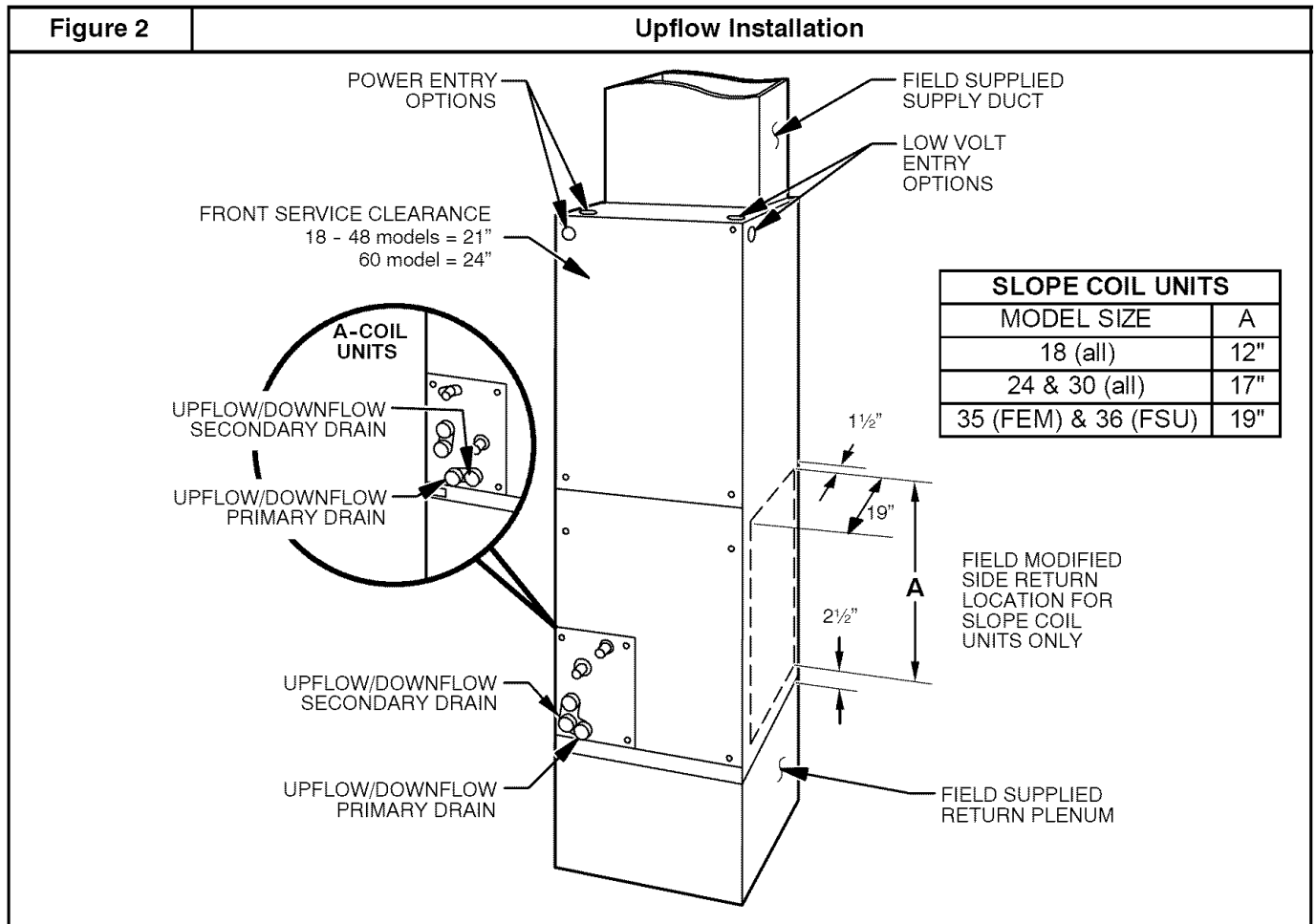

B. DOWNFLOW INSTALLATION

In this application, field conversion of the evaporator coil is required using accessory Downflow Kit along with an accessory Base Kit. See installation instructions packaged with accessory kit. See Product Specification literature for kit part numbers.

C. HORIZONTAL INSTALLATION

Unit must NOT be installed with access panels facing up or down. Access panels must only face to the side.

FEM and FSM models are factory built for horizontal left installation (refer to Figures 3 and 4). They can be field converted to horizontal right (accessory Gasket Kit re-

quired, see Product Specification literature for part number). Refer to Figures 5 and 6.

FSU models require accessory kits for any horizontal installation (see Product Specification literature for required accessory kits).

NOTE: When suspending unit from ceiling, dimples in casing indicate suitable location of screws for mounting metal support straps (refer to Figure 3).

NOTE: For optimum condensate drainage performance in horizontal installations, unit should be leveled along its length and width.

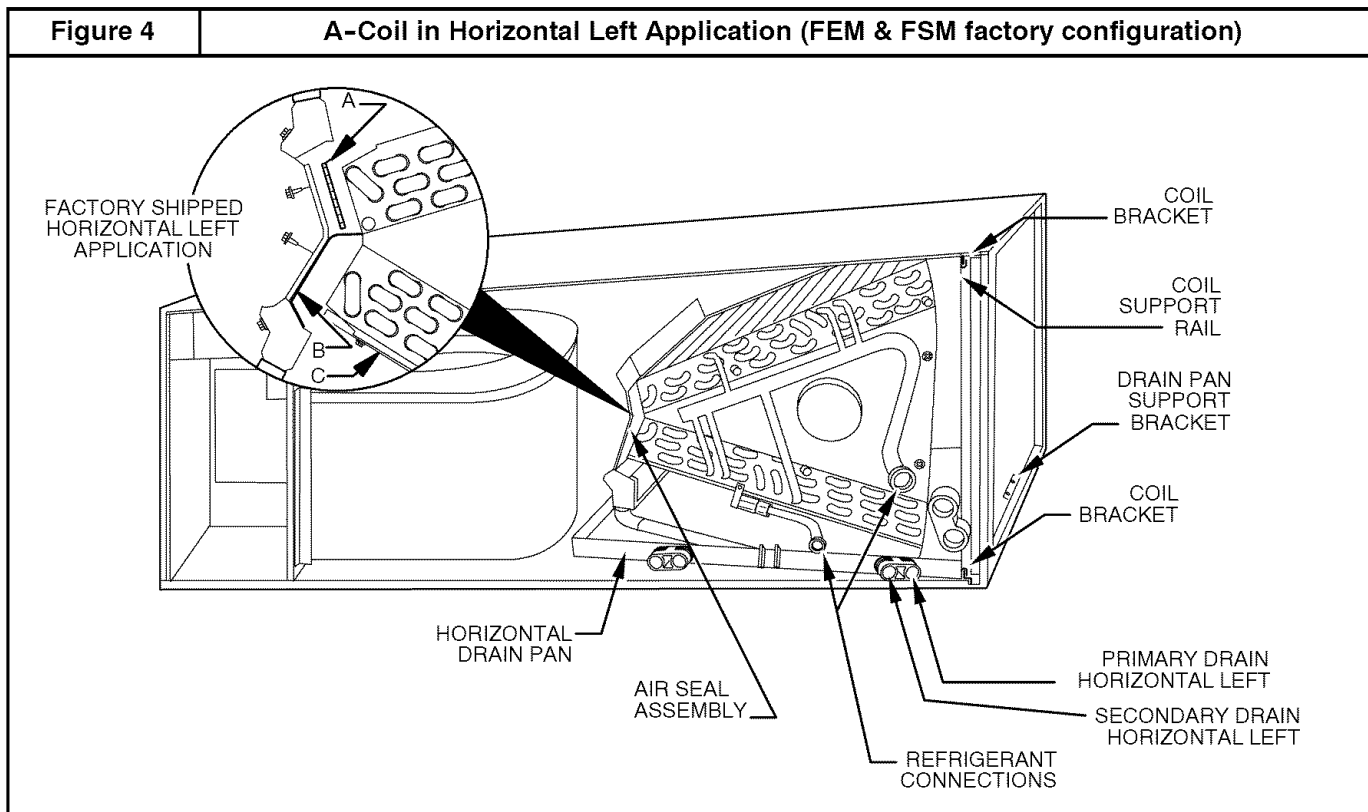
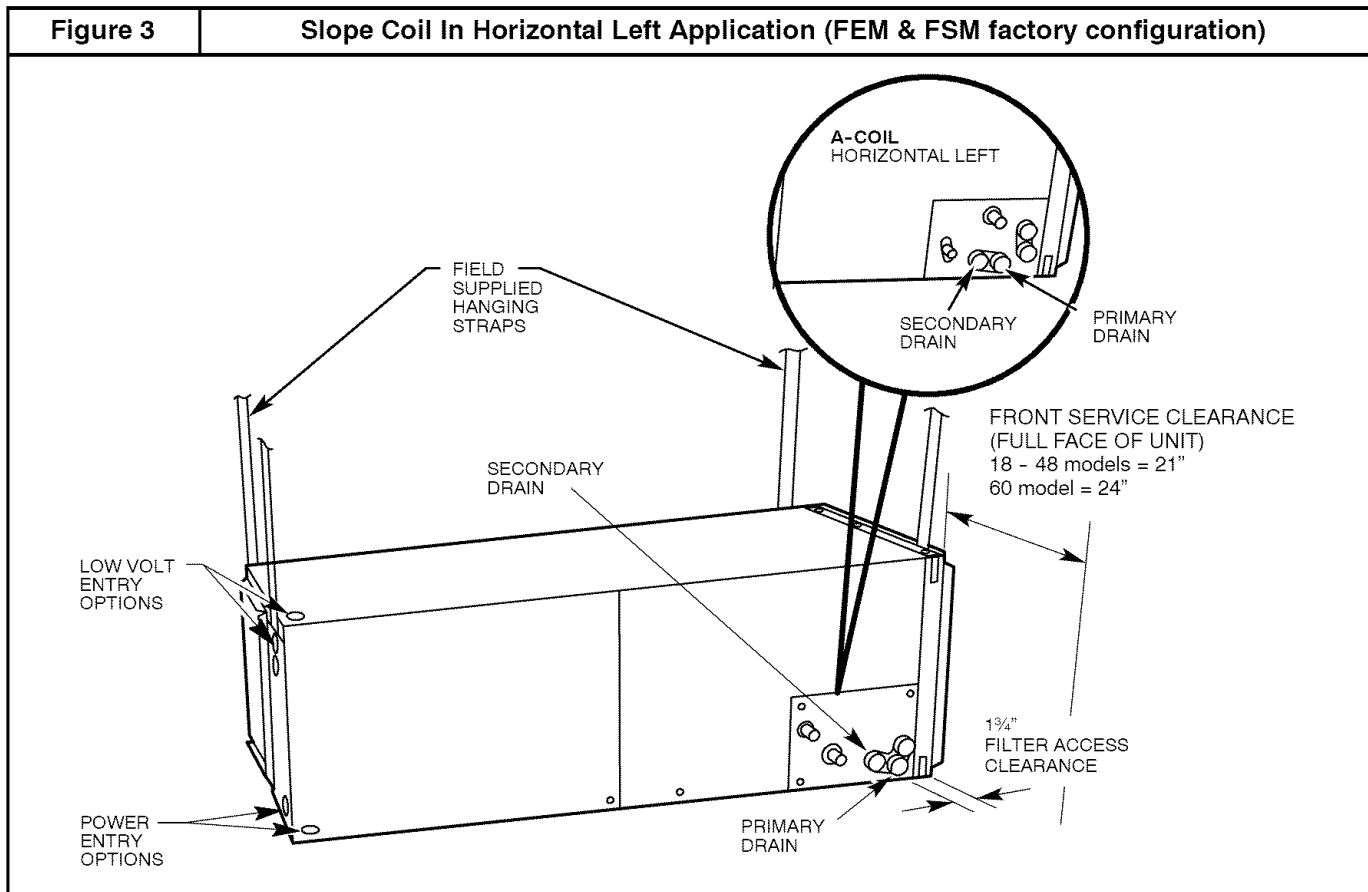

Horizontal Right Conversion of Units With Slope Coils

1. Remove blower and coil access panel and fitting panel (refer to Figure 5).
2. Remove coil mounting screw securing coil assembly to right side casing flange.
3. Remove coil assembly.
4. Lay fan coil unit on its right side and reinstall coil assembly with condensate pan down (refer to Figure 5).
5. Attach coil to casing flange using coil mounting screw previously removed.
6. Align holes with tubing connections and condensate pan connections, and reinstall access panels and fitting panel. After brazing, make sure liquid and suction tube grommets are in place to prevent air leaks and cabinet sweating.

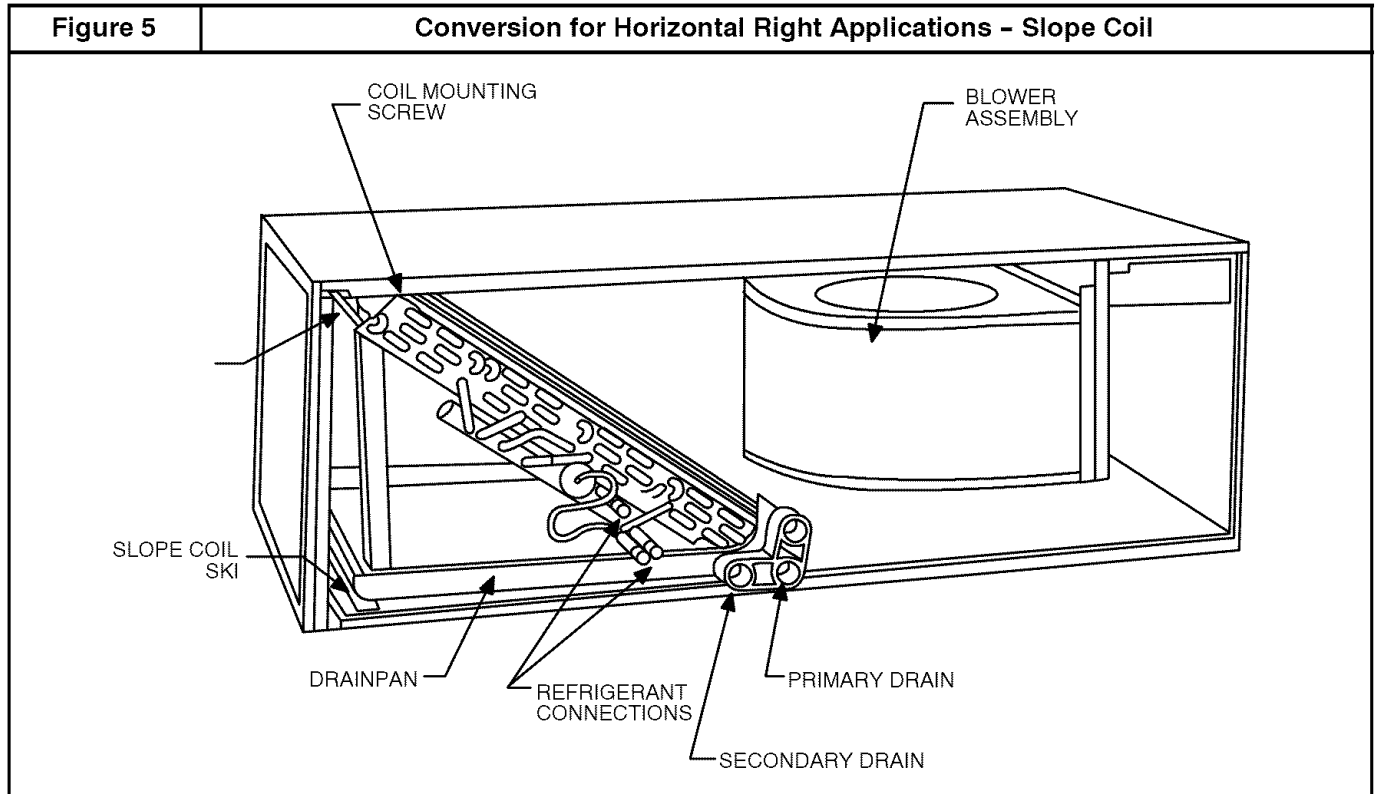

Horizontal Right Conversion of Units With A-Coils

1. Remove blower and coil access panel and fitting panel (refer to Figure 6).
2. Remove coil mounting screw securing coil assembly to right side casing flange.
3. Remove coil assembly.
4. Lay fan coil unit on its right side and reinstall coil assembly with condensate pan down (refer to Figure 6).
5. Remove horizontal drain pan support bracket from coil support rail on left side of unit and reinstall on coil support rail on right side of unit.
6. Convert air-seal assembly for horizontal right (refer to Figure 6).
 - a. Remove air-seal assembly from coil by removing 4 screws.
 - b. Remove coil drip flanges from A-coil and reinstall on right side of coil (same side as horizontal drain pan).
 - c. Remove filler plate (A) and install air splitter (B) in place of filler plate.
 - d. Install filler plate (A) as shown in horizontal right application.
 - e. Remove condensate troughs (C) and install on opposite tube sheets.
 - f. Install hose onto plastic spout.
7. Install horizontal pan on right side of coil assembly.
8. Slide coil assembly into casing. Be sure coil bracket on each corner of vertical pan engages coil support rails.
9. Reinstall 2 snap-in clips to correctly position and secure coil assembly in unit. Be sure clip with large offsets is used on right side of unit to secure horizontal pan.
10. Remove 2 oval coil access panel plugs and reinstall into holes on left side of coil access panel and fitting panel.
11. Remove insulation knockouts on right side of coil access panel

12. Reinstall access fitting panels, aligning holes with tubing connections and condensate pan connections. Be sure to reinstall metal clip between fitting panel and vertical condensate pan.

13. After brazing, make sure liquid and suction tube grommets are in place to prevent air leaks and cabinet sweating.

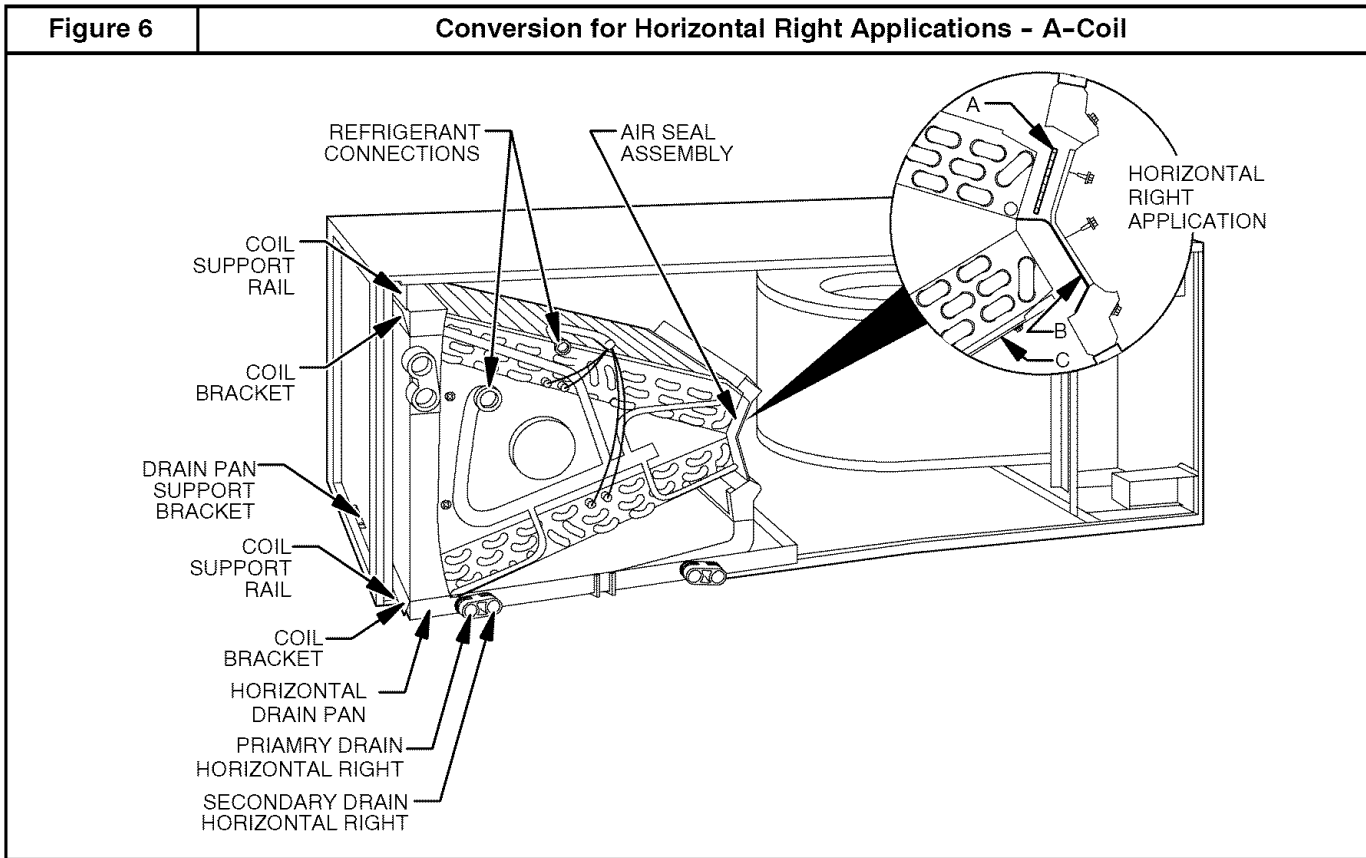

D. MANUFACTURED HOUSING AND MOBILE HOME APPLICATIONS

1. Fan coil unit must be secured to the structure using field-supplied hardware.
2. Allow a minimum of 24 inches clearance from access panels.
3. Recommended method of securing for typical applications:
 - a. If fan coil is away from wall, attach pipe strap to top of fan coil using No. 10 self tapping screws. Angle strap down and away from back of fan coil, remove all slack, and fasten to wall stud of structure using $\frac{5}{16}$ " lag screws. Typical both sides of fan coil.
 - b. If fan coil is against wall, secure fan coil to wall stud using $\frac{1}{8}$ " wide right-angle brackets. Attach brackets to fan coil using No. 10 self tapping screws and to wall stud using $\frac{5}{16}$ " lag screws (refer to Figure 7).

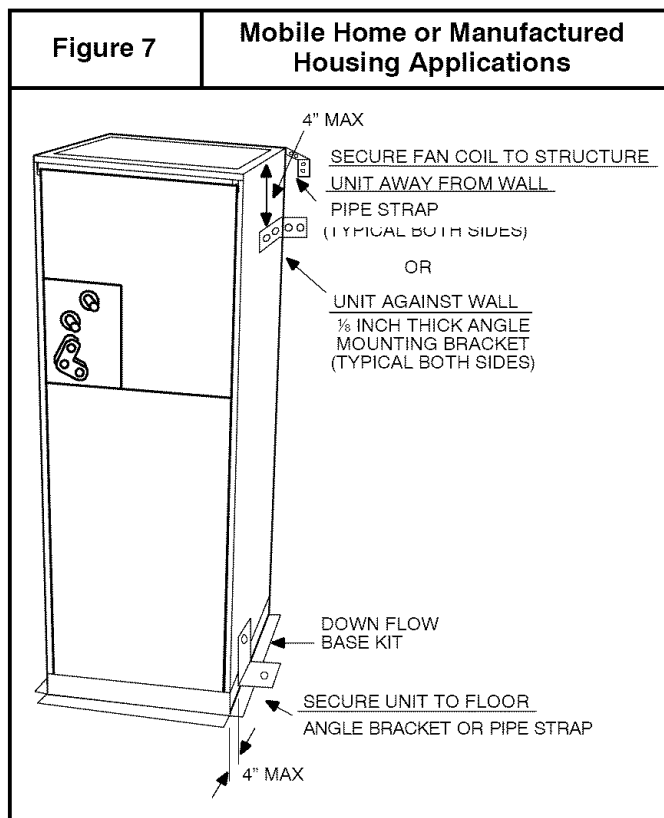

NOTE: Modular units can be disassembled and components moved separately to installation area for reassembly. This process accommodates small scuttle holes and limiting entrances to installation sites (refer to Figure 8).

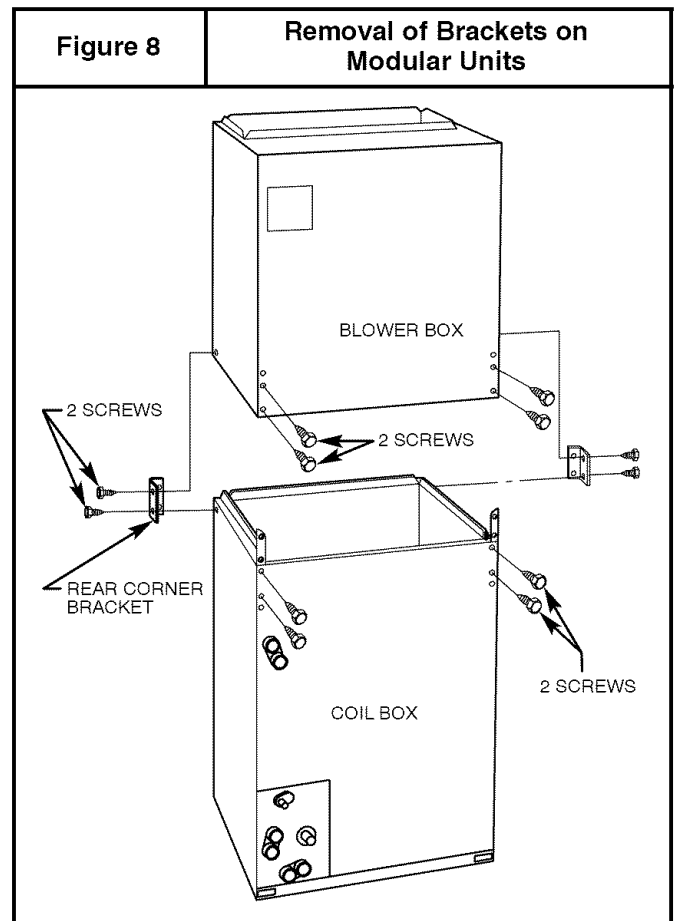

AIR DUCTS

Connect supply-air duct over the outside of 3/4" flanges provided on supply-air opening. Secure duct to flange using proper fasteners for type of duct used, and seal duct-to-unit joint. If return-air flanges are required, install factory authorized accessory kit.

Use flexible connectors between duct work and unit to prevent transmission of vibration. When electric heater is installed, use heat-resistant material for flexible connector between duct work and unit at discharge connection. Duct work passing through unconditioned space must be insulated and covered with vapor barrier.

ELECTRICAL CONNECTIONS

All Fan Coil models utilize an electronic fan board which has a low voltage circuit protective fuse (5 amp), fan motor speed tap terminal (SPT), and time delay relay (TDR). To disable the TDR feature, snip the jumper wire JW1 (refer to Figure 9).

Before proceeding with electrical connections, make certain that supply voltage, frequency, phase, and circuit ampacity are as specified on the unit rating plate. See unit wiring label for proper field high and low voltage wiring. Make all electrical connections in accordance with the NEC and any local codes or ordinances that may apply. Use copper wire only. The unit must have a separate branch electric circuit with a field-supplied disconnect switch located within sight from and readily accessible from the unit.

Duct work Acoustical Treatment

Metal duct systems that do not have a 90 degree elbow and 10 feet of main duct before first branch takeoff may require internal acoustical insulation lining. As an alternative, fibrous duct work may be used if constructed and installed in accordance with the latest edition of SMACNA construction standard on fibrous glass ducts. Both acoustical lining and fibrous duct work shall comply with National Fire Protection Association as tested by UL Standard 181 for Class 1 air ducts.

NOTE: When a pull-out type disconnect is removed from the unit, only the Load side of the circuit is de-energized. The Line side remains live until the main (remote) disconnect is turned off.



WARNING

ELECTRICAL SHOCK or UNIT DAMAGE HAZARD

Failure to follow this warning could result in personal injury, death, and/or unit damage.

If a disconnect switch is to be mounted on unit, select a location where drill and fasteners will not contact electrical or refrigeration components.



WARNING

ELECTRICAL SHOCK HAZARD

Failure to follow this warning could result in personal injury or death.

Turn off the main (remote) disconnect device before working on incoming (field) wiring. Incoming (field) wires on the line side of the disconnect found in the fan coil unit remain live, even when the pull-out is removed. Service and maintenance to incoming (field) wiring cannot be performed until the main disconnect switch (remote to the unit) is turned off.

Figure 9

Fan Coil Printed Circuit Board

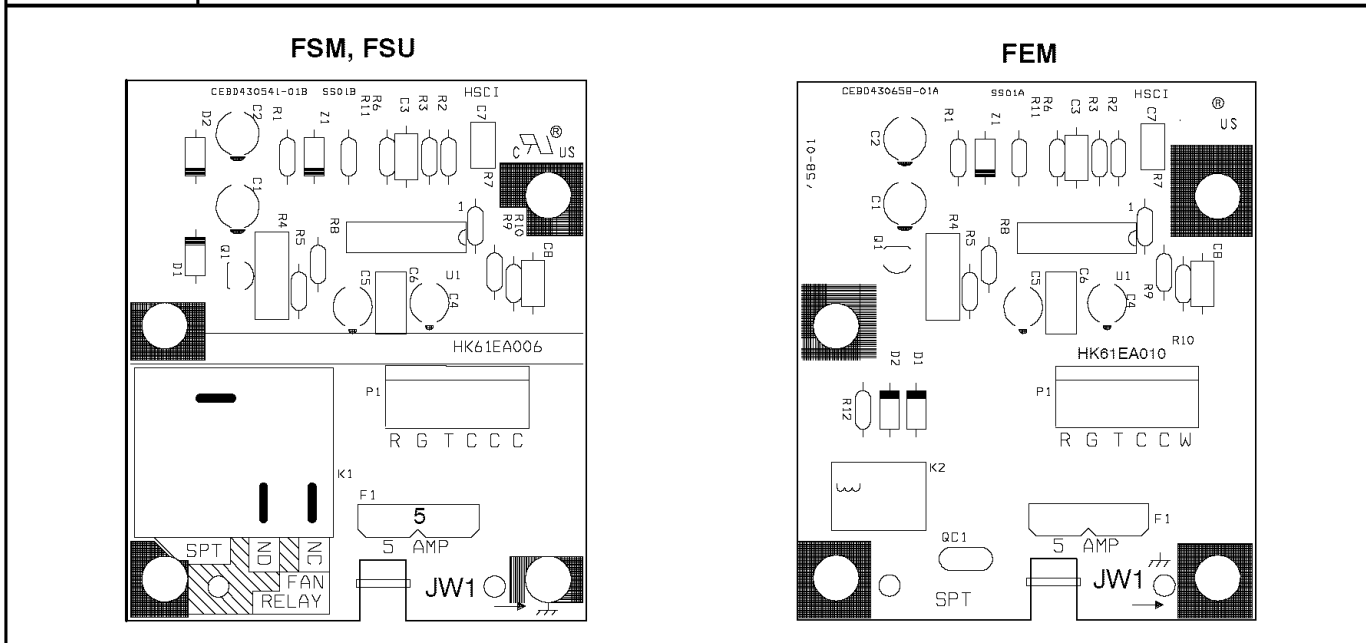

A. LINE VOLTAGE CONNECTIONS

Fan Coils installed without electric heat require the use of a factory-authorized Power Plug Kit (EBAC01PLG). This kit provides the electrical connections necessary to supply the unit with 208/230V power when electric heat is not present. For units without electric heat:

1. Connect 208/230V power leads from field disconnect to yellow and black stripped leads on Power Plug (EBAC01PLG).
2. Connect ground wire to unit ground lug.
3. When installing an electric heater, remove and discard power plug (if equipped) from fan coil and connect male plug from heater to female plug from unit wiring harness. (See Electric Heater Installation Instructions.)

B. 24V CONTROL SYSTEM

Connection to Unit

Wire low voltage in accordance with wiring label on the blower (also refer to Figures 10, 11, 12, 13, and 14). Use 18 AWG color-coded, insulated (35 °C minimum) wire to make the low-voltage connections between the thermostat, the unit, and the outdoor equipment. If the thermostat is located more than 100 feet from the unit (as measured along the low voltage wire), use 16 AWG color-coded, insulated (35 °C minimum) wire. All wiring must be NEC Class 1 and must be separated from incoming power leads. Refer to outdoor unit wiring instructions for additional wiring recommendations.

Heater Staging

The controls are factory circuited for single-stage operation (refer to Figures 11 & 12). When 2 stages are desired, cut W3 at the W2 wire nut, strip, and reconnect according to the thermostat kit instruction (refer to Figure 13 - outdoor thermostat optional). When 3 stages are desired, cut the W2 wire nut off and discard. Strip W2, W3, and E, and reconnect according to the thermostat kit instructions (refer to Figure 14 outdoor thermostats optional).

⚠ CAUTION

UNIT OPERATION HAZARD

Failure to follow this caution may result in improper product operation.

If W2, W3, and E on any 3 stage heater (18, 20, 24, or 30kW) are individually connected - as with outdoor thermostats or any other situation - emergency heat relay must be used. If relay is not used, blower may not operate when heaters are energized.

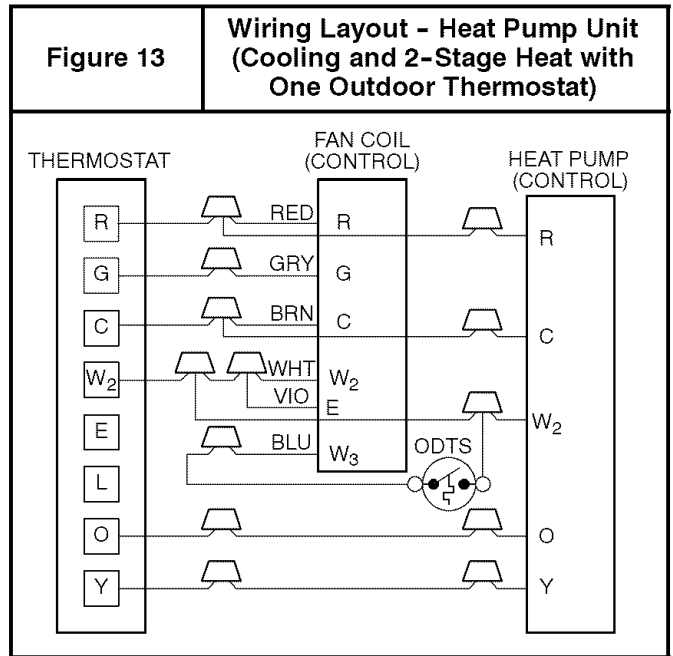
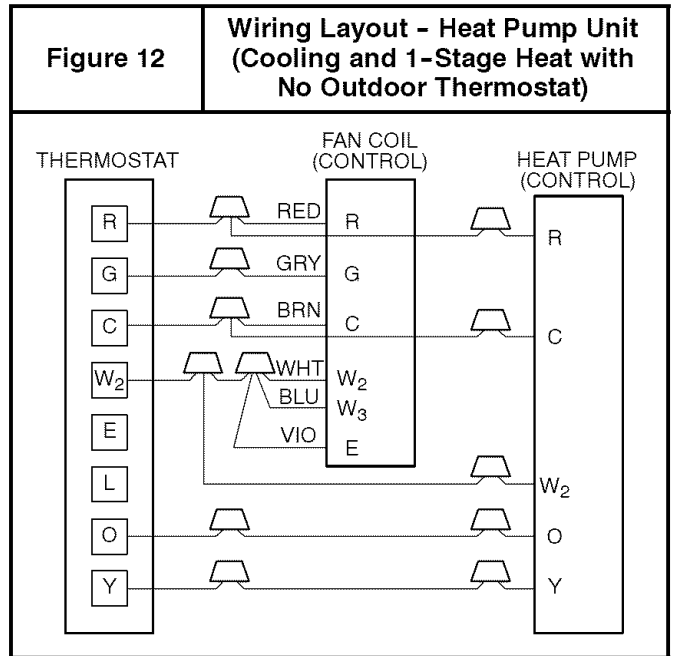
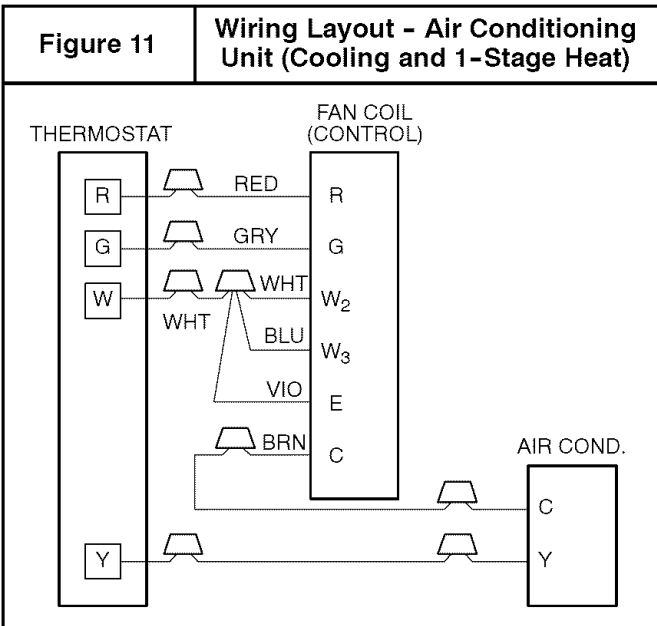
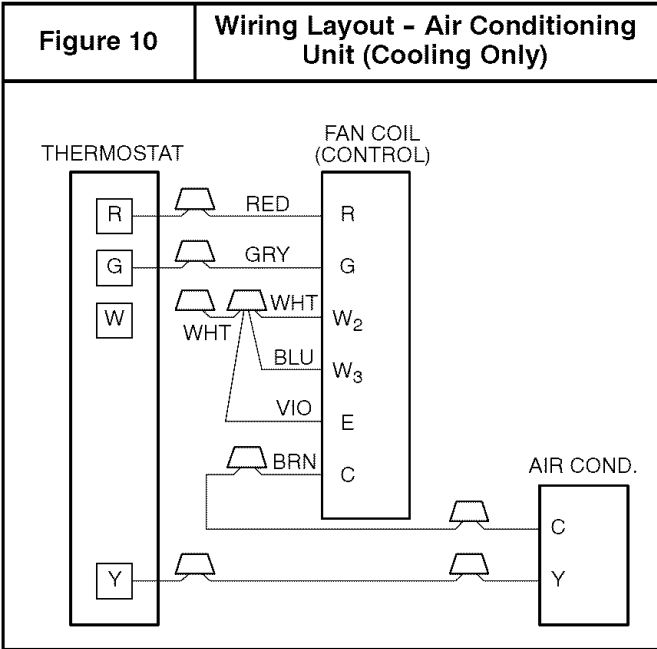

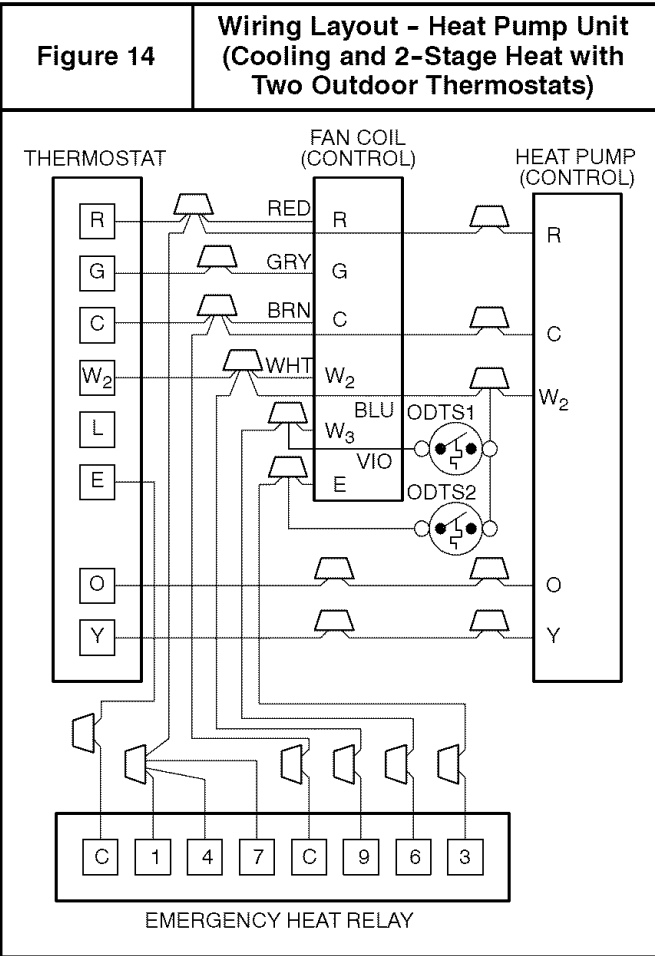

Transformer Information

Transformer is factory wired for 230V operation. For 208V applications, disconnect the black wire from the 230V terminal on transformer and connect it to the 208V terminal (refer to Figure 15).

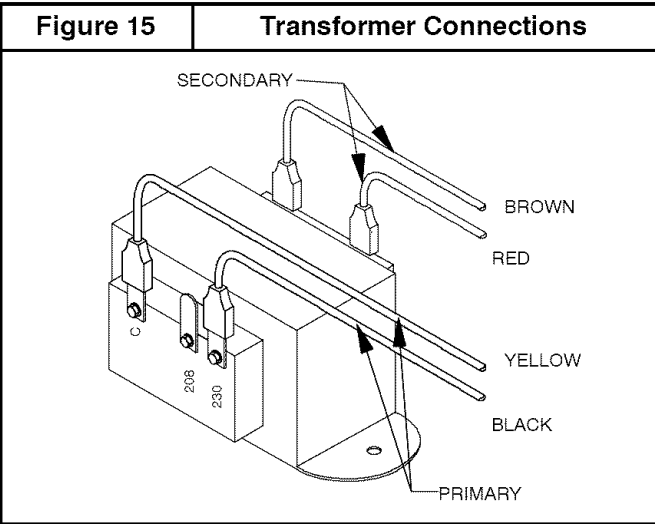

C. GROUND CONNECTIONS

⚠ WARNING

ELECTRICAL SHOCK HAZARD

Failure to establish uninterrupted or unbroken ground could result in personal injury and/or death.

According to NEC, ANSI/NFPA 70, and local codes, the cabinet must have an uninterrupted or unbroken ground in order to minimize potential for personal injury or death if an electrical fault should occur. The ground may consist of electrical wire or metal conduit when installed in accordance with existing electrical codes. If conduit connection uses reducing washers, a separate ground wire must be used.

NOTE: Use UL listed conduit and conduit connectors for connecting supply wire(s) to unit to obtain proper grounding. Grounding may also be accomplished by using grounding lugs provided in control box.

D. MINIMUM CFM AND MOTOR SPEED SELECTION

Units with or without electric heaters require a minimum CFM. Refer to the unit wiring label to ensure that the fan speed selected is not lower than the minimum fan speed indicated.

FEM models: fan speed selection is done at the fan motor. To change motor speeds, reposition wire at fan motor speed terminals labeled 1-2-3 (refer to Figure 16).

FSM and FSU models: fan speed selection is done at the fan relay on the electronic fan board. To change motor speeds, disconnect fan lead used on relay terminal (SPT) and replace with motor speed lead desired (refer to Figure 17). Save insulating cap and place on motor lead removed from relay.

NOTE: In low static applications, lower motor speed tap should be used to reduce possibility of water being blown off coil.

All units have 2 or 3 motor speed taps. Low speed (red or 1) is designed for mismatch outdoor unit applications. Medium speed (blue or 2) is designed for straight matched operations. High speed (black or 3) is used with high external static duct situations on straight matched systems.

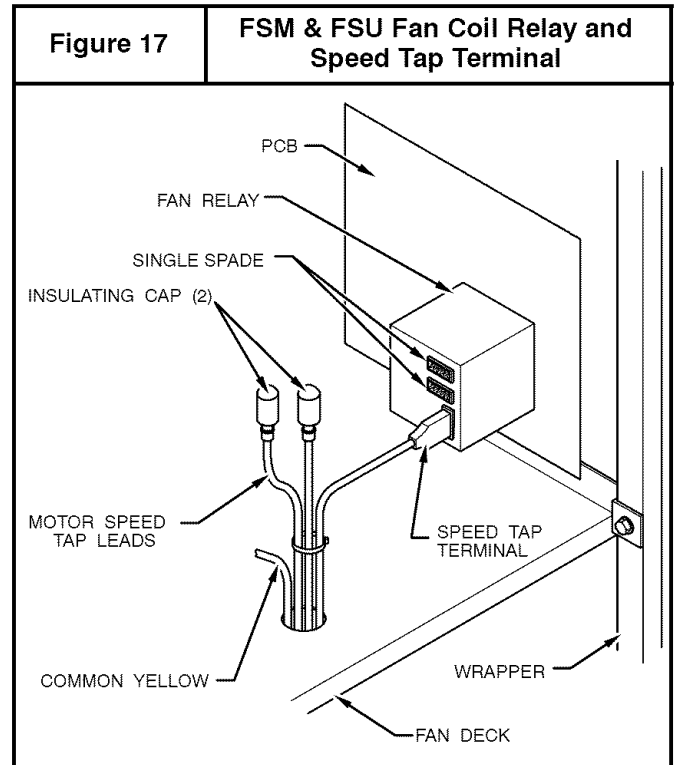
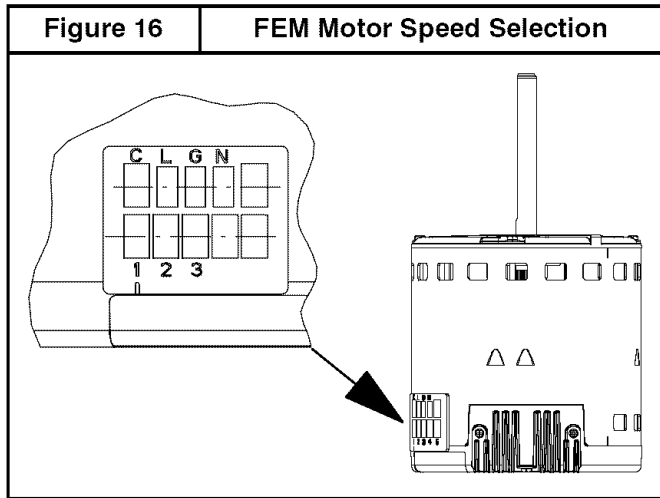

REFRIGERANT TUBING

Size and install refrigerant lines according to information provided with outdoor unit. Route refrigerant lines to the fan coil in a manner that will not obstruct service access to the unit or removal of the filter.

1. Find the liquid tube grommet in the small-parts bag and slide it onto the liquid refrigerant line (field line-set).
2. Remove the lower door. Remove the tubing plate (with suction tube grommet) and slide the plate with grommet onto the refrigerant lines (field line-set), away from braze joints.
3. Remove rubber plugs from coil stubs using a pulling and twisting motion. Hold coil stubs steady to avoid bending or distorting.
4. Wrap TXV and nearby tubing with a heat-sinking material such as a wet cloth.

5. Fit refrigerant lines into coil stubs. Wrap a heat sinking material such as a wet cloth behind braze joints.
6. Braze using a Sil-Fos or Phos-copper alloy.
7. After brazing, allow joints to cool. Slide tubing plate back into place and position grommets around suction and liquid tubes to ensure air seal.

REFRIGERANT METERING DEVICE

FEM2, FSM2, FSU2 Models:

These Fan Coils have a factory installed hard shut-off TXV designed only for use with R-22 refrigerant. Use only with outdoor units designed for R-22.

FEM4, FSM4, FSU4 Models:

These Fan Coils have a factory installed hard shut-off TXV designed only for use with R-410A refrigerant. Use only with outdoor units designed for R-410A.

TXV is factory set and not field adjustable.

⚠ CAUTION

PRODUCT DAMAGE HAZARD

Failure to follow this caution may result in product damage.

Braze with Sil-Fos or Phos-copper alloy on copper-to-copper joints and wrap a wet cloth around rear of fitting to prevent damage to TXV.

⚠ CAUTION

PRODUCT DAMAGE HAZARD

Failure to follow this caution may result in product damage.

This Fan Coil has a hard shut-off TXV metering device. A compressor Hard Start Kit is REQUIRED in all applications where the matching outdoor unit has a single-phase reciprocating compressor.

CONDENSATE DRAINS

Unit is provided with primary and secondary $\frac{3}{4}$ " NPT drain connections. Refer to Figures 2, 3, 4, 5, and 6 to identify the primary and secondary locations. To prevent property damage and achieve optimum drainage performance, BOTH primary and secondary drain lines should be installed and include properly sized condensate traps (refer to Figure 18). Factory approved condensate traps are available (accessory part number EBAC01CTK).

Install traps in the condensate lines as close to the coil as possible (refer to Figure 20), but avoid blocking filter access panel.

Install drain lines below the bottom of the drain pan and pitch the drain lines down from the coil at least $\frac{1}{4}$ inch per foot of run. Horizontal runs over 15 feet long must also have an anti-siphon air vents (stand pipes), installed ahead of the horizontal runs. Extremely long horizontal runs may require oversized drain lines to eliminate air trapping.

Route primary drain line to the outside or to a floor drain. Check local codes before connecting to a waste (sewer) line.

Route the secondary drain line to a place in compliance with local installation codes where it will be noticed when unit is operational. Condensate flowing from secondary (overflow) drain indicates a plugged primary drain - unit requires service or water damage will occur.

Prime all traps, test for leaks, and insulate drain lines where sweating could cause water damage. Consult local codes for additional requirements or precautions.

If a gravity drain cannot be used, install a condensate pump. Install the pump as close to the indoor section as possible.

Be sure to install plastic push-in plugs in unused condensate drain holes.

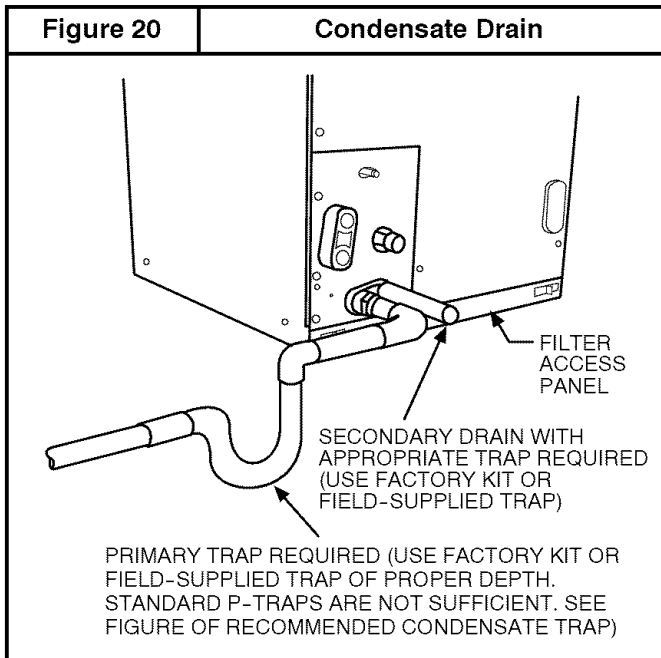
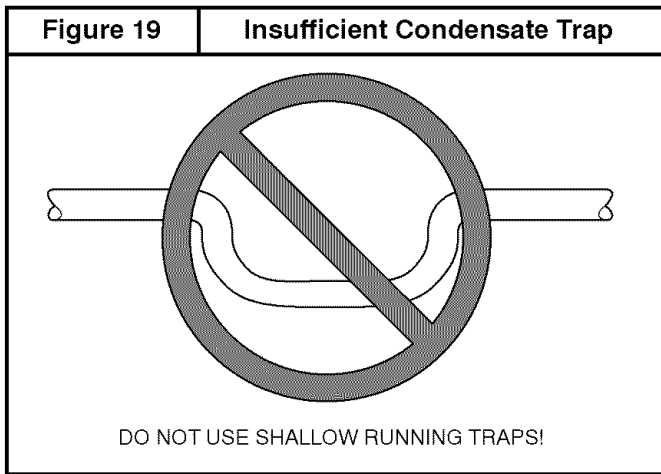
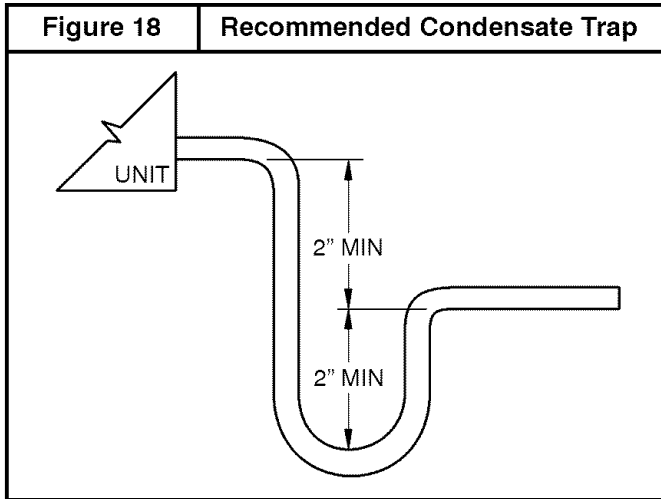

⚠ CAUTION

PRODUCT or PROPERTY DAMAGE HAZARD

Failure to follow this caution may result in product or property damage.

Use only full size P-traps in the condensate line (refer to Figure 18). Shallow, running traps are inadequate and DO NOT allow proper condensate drainage (refer to Figure 19).

ACCESSORIES

A. ELECTRONIC AIR CLEANER

The Electronic Air Cleaner may be connected to FSM and FSU fan coils as shown in Figure 21. This method requires a field supplied transformer. See Electronic Air Cleaner literature for kit requirements.

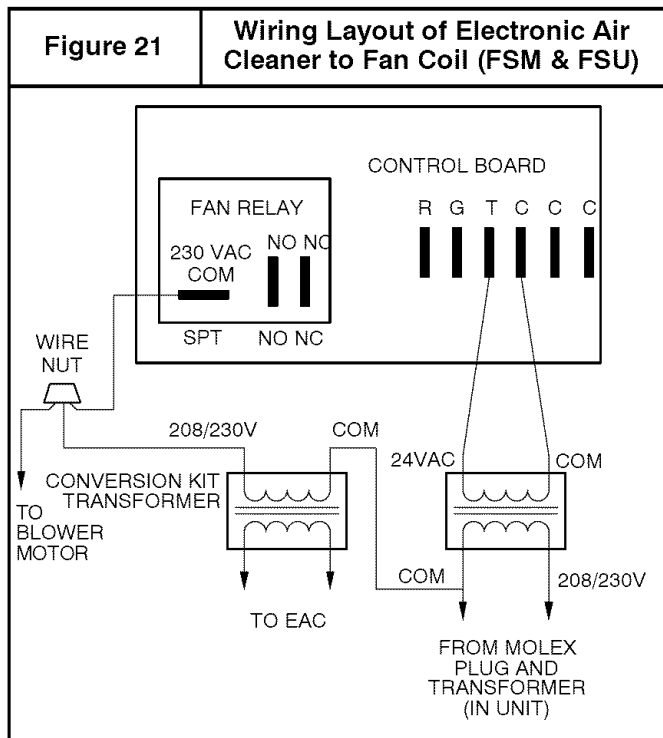

B. HUMIDIFIER

Connect humidifier and humidistat to fan coil unit as shown in Figures 22 & 23.

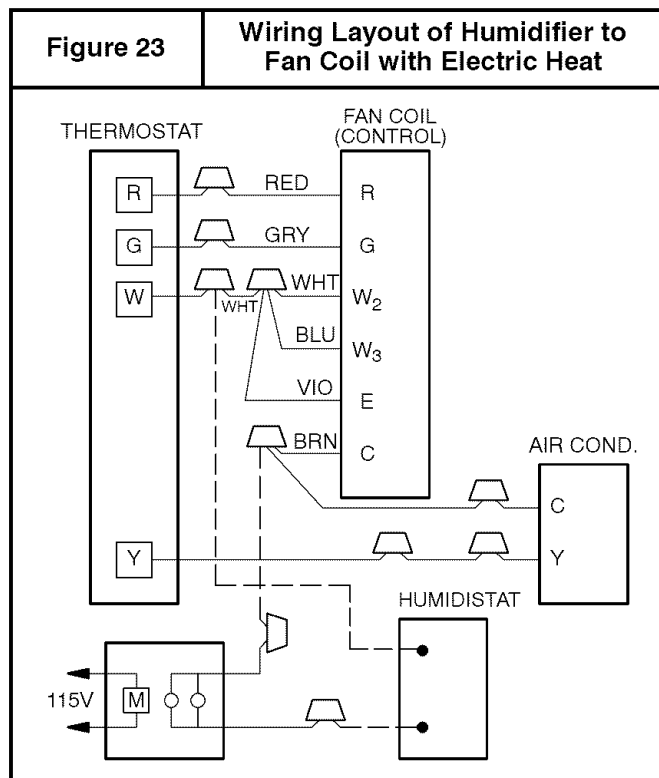
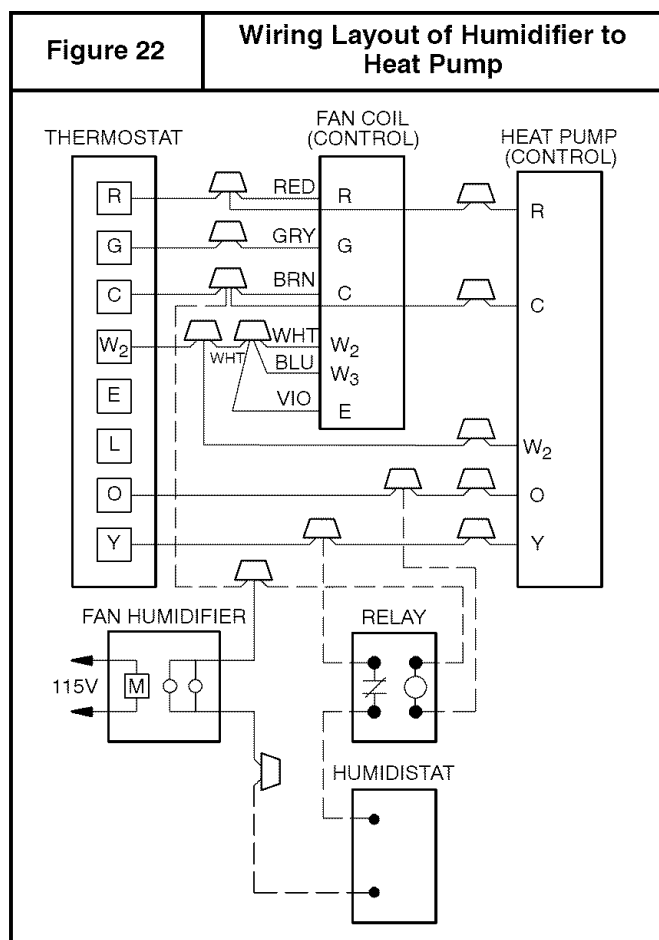

SEQUENCE OF OPERATIONS

A. CONTINUOUS FAN

Thermostat closes R to G. G energizes fan relay on electronic fan board which completes circuit to indoor blower motor. When G is de-energized, there is a 90 second delay before relay opens.

B. COOLING MODE

Thermostat energizes R to G, R to Y, and R to O (heat pump only). G energizes fan relay on electronic fan board which completes circuit to indoor blower motor. When G is de-energized, there is a 90 second delay before fan relay opens.

C. HEAT PUMP HEATING MODE

Thermostat energizes R to G and R to Y. G energizes fan relay on electronic fan board which completes circuit to indoor blower motor. When G is de-energized, there is a 90 second delay before fan relay opens.

D. HEAT PUMP HEATING WITH AUXILIARY ELECTRIC HEAT

Thermostat energizes R to G, R to Y, and R to W. G energizes fan relay on PCB which completes circuit to indoor blower motor. W energizes electric heat relay(s) which completes circuit to heater element(s). When W is de-energized, electric heat relay(s) open, turning off heater elements. When G is de-energized there is a 90 second delay before fan relay opens.

E. ELECTRIC HEAT OR EMERGENCY HEAT MODE

Thermostat closes R to W. W energizes electric heat relay(s) which completes circuit to heater element(s). Blower motor is energized through normally closed contacts on fan relay. When W is de-energized, electric heat relay(s) opens.

START-UP PROCEDURE

Refer to outdoor unit Installation Instructions for system start-up instructions and refrigerant charging method details.

CARE AND MAINTENANCE

The system should be regularly inspected by a qualified service technician. Consult the servicing dealer for recommended frequency.

Between visits, the only consumer service recommended or required is air filter maintenance and condensate drain operation.

Air Filter

Inspect air filters at least monthly and replace or clean as required. Disposable type filters should be replaced. Re-usable type filters may be cleaned by soaking in mild detergent and rinsing with cold water. Install filters with the arrows on the side pointing in the direction of air flow.

Condensate Drain

During the cooling season check at least monthly for free flow of drainage and clean if necessary.



CAUTION

PRODUCT DAMAGE HAZARD

Failure to follow this caution may result in poor unit performance and/or product damage.

Never operate unit without a filter. Factory authorized filter kits must be used when locating the filter inside the unit. For those applications where access to an internal filter is impractical, a field-supplied filter must be installed in the return duct system.

R-410A QUICK REFERENCE GUIDE

- R-410A refrigerant operates at 50% - 70% higher pressures than R-22. Be sure that servicing equipment and replacement components are designed to operate with R-410A.
- R-410A refrigerant operates at 50% - 70% higher pressures than R-22. Be sure that servicing equipment and replacement components are designed to operate with R-410A.
- R-410A refrigerant cylinders are rose colored.
- Recovery cylinder service pressure rating must be 400 psig, DOT 4BA400 or DOT BW400.
- R-410A systems should be charged with liquid refrigerant. Use a commercial type metering device in the manifold hose.
- Manifold sets should be 750 psig high-side and 200 psig low-side with 520 psig low-side retard.
- Use hoses with 750 psig service pressure rating.
- Leak detectors should be designed to detect HFC refrigerant.
- R-410A, as with other HFC refrigerants, is only compatible with POE oils.
- POE oils absorb moisture rapidly. Do not expose oil to atmosphere.
- POE oils may cause damage to certain plastics and roofing materials.
- Vacuum pumps will not remove moisture from oil.
- A liquid line filter-drier is required on every unit.
- Do not use liquid line filter-driers with rated working pressures less than 600 psig.
- Do not install a suction line filter-drier in liquid line.
- Wrap all filter-driers and service valves with wet cloth when brazing.
- Do not use with an R-22 TXV.
- If indoor unit is equipped with an R-22 TXV, it must be changed to an R-410A TXV.
- Do not use capillary tube indoor coils.
- Never open system to atmosphere while it is under a vacuum.
- When system must be opened for service, break vacuum with dry nitrogen and replace all filter-driers.
- Do not vent R-410A into the atmosphere.
- Observe all **WARNINGS**, **CAUTIONS**, **NOTES**, and **bold** text.