

# Installation Instructions

PGF, PGC, PGS, GPFM, GPCM, GPSM  
1<sup>1</sup>/<sub>2</sub> to 5 TON

## COMBINATION UNITS GAS HEAT / ELECTRIC COOL

### Models

|             |             |
|-------------|-------------|
| PGF018K040F | GPFM18K040F |
| PGF024K040F | GPFM24K040F |
| PGF024K060F | GPFM24K060F |
| PGF030K060F | GPFM30K060F |
| PGF030K080F | GPFM30K080F |
| PGF036K060F | GPFM36K060F |
| PGF036K080F | GPFM36K080F |
| PGF036K100F | GPFM36K100F |
| PGF042K080F | GPFM42K080F |
| PGF042K100F | GPFM42K100F |
| PGF048K080F | GPFM48K080F |
| PGF048K120F | GPFM48K120F |
| PGF060K100F | GPFM60K100F |
| PGF060K140E | GPFM60K140E |
| PGC018K040F | GPCM18K040F |
| PGC024K040F | GPCM24K040F |
| PGC024K060F | GPCM24K060F |
| PGC030K060F | GPCM30K060F |
| PGC030K080F | GPCM30K080F |
| PGC036K060F | GPCM36K060F |
| PGC036K080F | GPCM36K080F |
| PGC036K100F | GPCM36K100F |
| PGC042K080F | GPCM42K080F |
| PGC042K100F | GPCM42K100F |
| PGC048K080F | GPCM48K080F |
| PGC048K120F | GPCM48K120F |
| PGC060K100F | GPCM60K100F |
| PGC060K140F | GPCM60K140F |
| PGS024K060F | GPSM24K060F |
| PGS030K080F | GPSM30K080F |
| PGS036K080F | GPSM36K080F |
| PGS036K100F | GPSM36K100F |
| PGS042K080F | GPSM42K080F |
| PGS042K100F | GPSM42K100F |
| PGS048K120F | GPSM48K120F |
| PGS060K140E | GPSM60K140E |

# UNIT DIMENSIONS

1-1/2 TO 3-1/2 TON

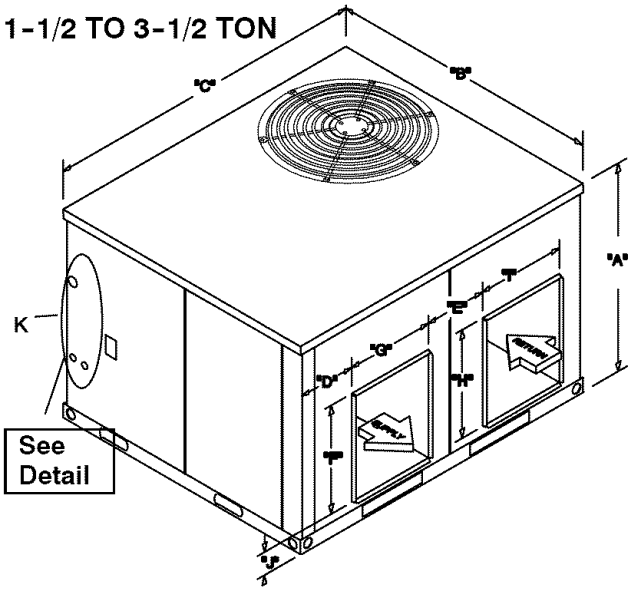

4 TO 5 TON

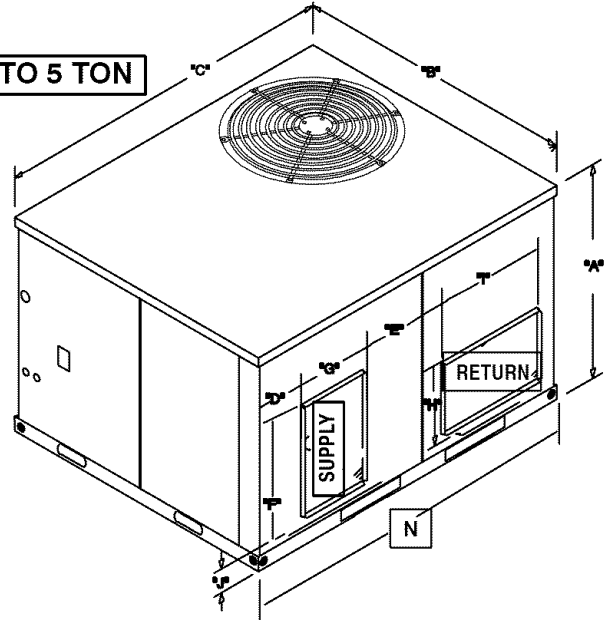

## BASE PAN - CHASSIS

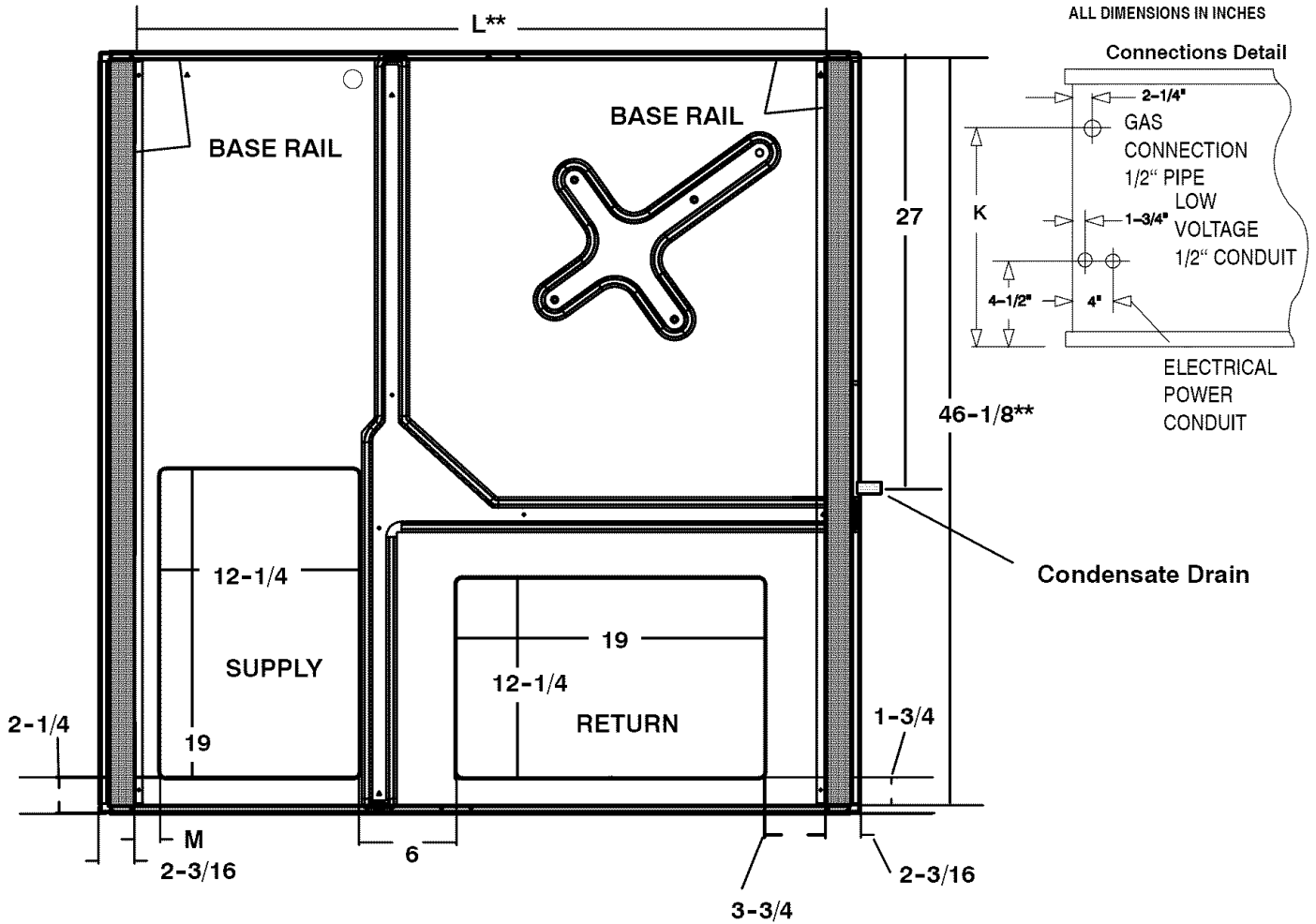

| UNIT SIZE          | A      | B      | C      | D     | E     | F  | G  | H  | I  | J     | K  | L      | M      | N      |
|--------------------|--------|--------|--------|-------|-------|----|----|----|----|-------|----|--------|--------|--------|
| 1-1/2 TO 3-1/2 Ton | 29-1/2 | 47-1/2 | 47-1/2 | 3     | 9-1/2 | 12 | 14 | 12 | 14 | 4-1/2 | 16 | 42-3/4 | 1-9/16 | 46-1/2 |
| 4 TO 5 Ton*        | 37-1/2 | 47-1/2 | 51-1/2 | 7-1/2 | 6-1/2 | 19 | 12 | 12 | 19 | 4-1/2 | 22 | 46-1/4 | 5-3/16 | 49-3/4 |

\*\* Measured from inside to inside on base rails.



## Ground Level Installation

Ground level platform requirements:

- The unit **MUST** be situated to provide safe access for servicing.
- Platform may be made of either concrete or pressure treated wood and **MUST** be level and strong enough to support unit weight.
- Position platform separate from building foundation.
- Install in well-drained area, with top surface of platform above grade level.
- Platform must be high enough to allow for proper condensate trap installation and drainage. See **FIGURE 3** and associated text for more information about condensate drainage.

## Rooftop Installation

Rooftop platform requirements:

- The unit **MUST** be situated to provide safe access for servicing.
- The existing roof structure **MUST** be adequate to support the weight of the unit or the roof **MUST** be reinforced.  
Check the weight of the unit in relation to the roof structure and local building codes or ordinances and reinforce roof structure if necessary. See the last page of this manual for unit weights.
- Support for the unit **MUST** be level and strong enough to carry unit weight. The support may consist of a platform or a combination of platform and roof beams or curb.
- See *Hoisting* section for hoisting instructions.

## HOISTING

**NOTE:** All access panels **MUST** be secured in place before hoisting.

The unit should be hoisted with two lifting slings. Attach the slings to rigging shackles that have been hooked through holes in the base rail.

Two spreader bars **MUST** be placed on top of the unit to protect the unit from damage from the pressure exerted by the slings. Make sure that all equipment is adequate to handle the weight of the unit and that the slings will not allow the unit to shift.

Refer to **FIGURE 17** on the back cover of this manual for illustrated rigging instructions and weight chart.

## DOWNFLOW CONVERSION

**NOTE:** In downflow applications with roof curbs or jack stands, the center rail under the unit must be removed. The center rail is attached to the base rail with screws.

These units are adaptable to downflow use. To convert to downflow use, follow these steps:

1. Remove the blockoff plates found in the return air compartment and the supply air compartment.

**NOTE:** Blockoff plate in the supply air compartment only contains one screw. If reinstalling plate, back part of plate **MUST** fit into mating dimples on flange. To reinstall, slant plate into dimples, then put plate into position and fasten with screw.

2. Install the removed plates on the horizontal return and supply air openings.
3. Install roof curb on the building. Be sure to follow all directions included with curb and all applicable building codes in your installation.

## Heating Vent Assembly

Refer to **FIGURE 2** and assemble as shown.

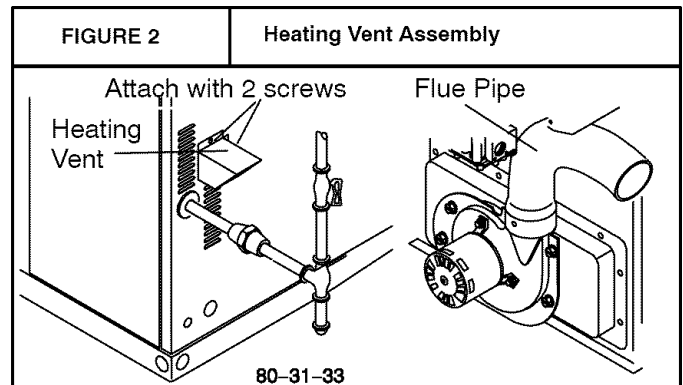

**CAUTION**  
DO NOT OPERATE THE UNIT WITHOUT THE VENT ASSEMBLY INSTALLED

## Condensate Drain

The condensate drain outlet is a  $\frac{3}{4}$ " (19.1mm) female PVC connection located at the bottom on the left hand side (see **FIGURE 3**).

The circulating blower creates a negative pressure on the condensate drain line that can prevent the condensate from draining properly. To combat this negative pressure, a field supplied condensate trap that will allow a standing column of water of at least 2" (50.8mm) **MUST** be installed. Top of outlet from trap **MUST** be at least 1" (25.4mm) below top of outlet from unit. **Install the trap as near to the unit as possible for proper drainage.**

A  $\frac{3}{4}$ " (19.1mm) drain line **MUST** be installed if required by local codes or if location of unit requires it. Run the drain line to an open drain or other suitable disposal point.

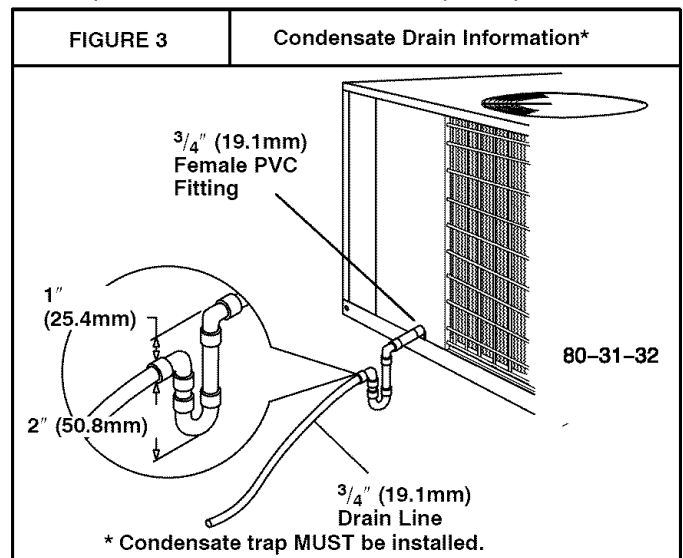

## 5. PRE-EXISTING COMMON VENT CHECK

If the installation of the combination unit involves removing an existing furnace from a common vent with other appliances, the existing venting system will probably be too large for the remaining appliances and they will not vent properly. The existing venting system **MUST** be checked by a qualified technician to ensure it is properly sized and vents properly.

## 6. GAS SUPPLY AND PIPING

**NOTE:** Because there are many types of liquified petroleum (LP) gases, the term LP as used in this manual refers to propane gas. If you intend to use any type of LP gas, proper precautions **MUST** be used in the handling, piping, and use of such gas. **NOTE:** In Canada, installations **MUST** be performed by licensed LP installers.

The UL/CSA Rating Plate located on the side panel on the unit contains the model number, type of gas and gas input rating, and other important information.

**⚠ WARNING**

**FIRE AND/OR EXPLOSION HAZARD**  
Failure to follow this warning could result in property damage, personal injury, and/or death.

Make certain the unit is equipped to operate on the type of gas available. Models designated as natural gas are to be used with natural gas only. Models designated for use with liquefied petroleum (LP) gas are shipped with orifices sized for commercially pure propane gas. They **MUST** not be used with butane or a mixture of butane and propane unless properly sized orifices are installed by a licensed LP installer.

### GAS PIPING

The gas supply line **MUST** be of adequate size to handle the Btu/hr requirements and length of the run for the unit being installed. Determine the minimum pipe size for natural gas from the table in **FIGURE 4** or **FIGURE 5**. Base the length of the run from the gas meter or source to the unit.

#### Gas Pipe Size

Btu ratings of all other gas appliances **MUST** be considered for sizing of main gas line. Check gas line to installation for compliance with local codes or, in the absence of local codes, with the National Fuel Gas Code ANSI Z223.1 or in Canada the National Standard CAN/CGA B149-1 or current editions.

| FIGURE 4                        |                       | Gas Pipe Size, Length and Btu/hr Capacity for Schedule 40 Iron Pipe (English) |        |        |        |  |
|---------------------------------|-----------------------|---|--------|--------|--------|--|
| NATURAL GAS                     |                       |   |        |        |        |  |
| Pipe Length (Includes Fittings) | Btu/hr (in thousands) |   |        |        |        |  |
|                                 | 3/4"                  | 1"  | 1 1/4" | 1 1/2" | 2"     |  |
| 20'                             | 190                   | 350   | 730    | 1,100  | 2,100  |  |
| 40'                             | 130                   | 245   | 500    | 760    | 1,450  |  |
| 60'                             | 105                   | 195   | 400    | 610    | 1,150  |  |
| LP GAS                          |                       |   |        |        |        |  |
| Pipe Length (Includes Fittings) | Btu/hr (in thousands) |   |        |        |        |  |
|                                 | 1/2"                  | 3/4"  | 1"     | 1 1/4" | 1 1/2" |  |
| 20'                             | 189                   | 393   | 732    | 1,496  | 2,299  |  |
| 40'                             | 129                   | 267   | 504    | 1,039  | 1,559  |  |
| 60'                             | 103                   | 217   | 409    | 834    | 1,275  |  |

| FIGURE 5                        |      | Gas Pipe Size, Length and Btu/hr Capacity for Schedule 40 Iron Pipe (English) |        |        |        |  |
|---------------------------------|------|---|--------|--------|--------|--|
| NATURAL GAS                     |      |   |        |        |        |  |
| Pipe Length (Includes Fittings) | kW** |   |        |        |        |  |
|                                 | 3/4" | 1"  | 1 1/4" | 1 1/2" | 2"     |  |
| 6.1m                            | 56   | 103   | 214    | 322    | 615    |  |
| 12.2m                           | 38   | 72  | 147    | 223    | 425    |  |
| 18.3m                           | 31   | 57  | 117    | 179    | 337    |  |
| LP GAS                          |      |   |        |        |        |  |
| Pipe Length (Includes Fittings) | kW** |   |        |        |        |  |
|                                 | 1/2" | 3/4"  | 1"     | 1 1/4" | 1 1/2" |  |
| 6.1m                            | 55   | 115   | 215    | 438    | 674    |  |
| 12.2m                           | 38   | 78  | 148    | 305    | 457    |  |
| 18.3m                           | 30   | 64  | 120    | 244    | 374    |  |

\*\*kW (Kilowatts) is the metric equivalent of Btu/hr.

### PIPING AT UNIT

#### Connections

**NOTE:** The rules listed apply to natural and LP gas pipe installations.

1. If installation is for LP gas, have LP gas installer use **TWO-STAGE REGULATION** and make all connections from storage tank to unit.
2. Use black iron or steel pipe and fittings or other pipe approved by local code.
3. If copper tubing is used, it **MUST** comply with limitation set in Fuel Gas Code.

**NOTE:** If a gas connector is used, it **MUST** be acceptable to local authority. Connector **MUST NOT** be used inside the furnace or be secured or supported by the furnace or ductwork.

**⚠ WARNING**

**FIRE AND/OR EXPLOSION HAZARD**  
Failure to do so could result in property damage, bodily injury or death.

Gas connector **MUST** be properly installed and can **NOT** be used inside the furnace.

4. Use pipe joint compound on external (male) threads **ONLY**. Joint compound **MUST** be resistant to any chemical action of LP gases. Do **NOT** put pipe compound on last 2 threads of pipe.
5. Use ground joint unions and install a drip leg no less than 3 inches (76 mm) long to trap dirt and moisture before it can enter gas valve.

**⚠ CAUTION**

Overtightening assembly may cause damage to the gas valve and/or wiring and may misalign the burners.

6. Use a wrench on gas valve when making connections to prevent gas valve from turning. Do **NOT** use a pipe wrench on the gas valve body.
7. Provide a 1/8 inch (3mm) National Pipe Thread (NPT) plug for test gauge connection immediately upstream of

the gas supply connection to the furnace if none is supplied with the gas valve of unit.

8. Install a manual shutoff valve and tighten all joints securely.
9. Make sure pilot tube and burner orifices are checked for leakage.

## ORIFICES

### Orifice Sizes

Orifice sizes **MUST** be matched to the heating value of the gas (see **FIGURE 6 AND TABLE 1 & 2**). Check with your gas supplier and the National Fuel Gas Code ANSI Z223.1.

**NOTE:** An LP Conversion Kit **MUST** be used for conversion to LP gas.

**TABLE 1 & 2: Equivalent Orifice Sizes at High Altitudes**

**NOTE:** For elevations above 2000 feet (610 meters), the Btu input rating **MUST** be reduced by 4% for each 1000 feet (305 meters) above sea level, unless the gas supplier's Btu/ft<sup>3</sup> content has already been adjusted for altitude. Check **Table 1 & 2** for the proper orifice sizes.

| FIGURE 6                      |                  | Orifice Sizes              |                     |
|-------------------------------|------------------|----------------------------|---------------------|
| Gas Type                      | Specific Gravity | Btu/ft <sup>3</sup> (kJ/L) | Pilot Orifice Sizes |
| Natural                       | 0.6              | 1000                       | .018#               |
| Propane                       | 1.53             | 2500                       | .011#               |
| #Adjust pilot flame as needed |                  |                            |                     |

| Table 1       | NATURAL GAS ORIFICE SIZING          |            |                 |                 |                 |                 |                 |                 |                 |
|---------------|-------------------------------------|------------|-----------------|-----------------|-----------------|-----------------|-----------------|-----------------|-----------------|
|               | MEAN ELEVATION FEET ABOVE SEA LEVEL |            |                 |                 |                 |                 |                 |                 |                 |
|               | 0 to 2000                           |            | 2001 to 4000    | 4001 to 5000    | 5001 to 6000    | 6001 to 7000    | 7001 to 8000    | 8001 to 9000    | 9001 to 10000   |
| Gas Output    | Orifice Drill #                     | Kit Number | Orifice Drill # | Orifice Drill # | Orifice Drill # | Orifice Drill # | Orifice Drill # | Orifice Drill # | Orifice Drill # |
| 040, 060, 080 | 44                                  | 1172664    | 45              | 46              | 47              | 47              | 48              | 48              | 49              |
| 100           | 41                                  | 1098575    | 43              | 43              | 43              | 44              | 44              | 45              | 46              |
| 120, 140      | 42                                  | 1098575    | 43              | 43              | 44              | 44              | 45              | 46              | 47              |

**NOTE:** The orifice sizes in the chart above derate the input rate at 4% per 1000 feet above sea level for altitudes exceeding 2000 feet above sea level. If converting from LP gas to Natural Gas at altitudes exceeding 2000 feet above sea level, a .018 pilot orifice (part # 503211) and gas valve conversion kit (part # 1147772) are required for conversion **OR** use kit # 1172664 plus the required orifice size # shown in Table 1. Natural Gas data is based on 0.60 specific gravity, a heating value of 1030 Btu/Cu.Ft., and 3.5" W.C. manifold pressure. For fuels with different specific gravity, consult the National Fuel Gas Code ANSI Z223.1-2002/NFPA 54-2002 or National Standard of Canada, Natural Gas and Propane Installation Code CSA B149.1-00.

| Table 2       | LP GAS ORIFICE SIZING               |            |                 |            |                 |            |                 |            |                 |            |
|---------------|-------------------------------------|------------|-----------------|------------|-----------------|------------|-----------------|------------|-----------------|------------|
|               | MEAN ELEVATION FEET ABOVE SEA LEVEL |            |                 |            |                 |            |                 |            |                 |            |
|               | 0 to 2000                           |            | 2001 to 4000    |            | 4001 to 7000    |            | 7001 to 9000    |            | 9001 to 10,000  |            |
| Gas Output    | Orifice Drill #                     | Kit Number | Orifice Drill # | Kit Number | Orifice Drill # | Kit Number | Orifice Drill # | Kit Number | Orifice Drill # | Kit Number |
| 040, 060, 080 | 55                                  | 1172663    | 55              | 1172663    | 56              | 1172665    | 56              | 1172665    | 57              | 1172666    |
| 100, 120, 140 | 54                                  | 1172662    | 55              | 1172663    | 55              | 1172663    | 56              | 1172665    | 56              | 1172665    |

**NOTE:** The orifice sizes in the chart above derate the input rate at 4% per 1000 feet above sea level for altitudes exceeding 2000 feet above sea level. LP Gas data is based on 1.52 specific gravity, a heating value of 2500 Btu/Cu.Ft., and 10.0" W.C. manifold pressure. For fuels with different specific gravity, consult the National Fuel Gas Code ANSI Z223.1-2002/NFPA 54-2002 or National Standard of Canada, Natural Gas and Propane Installation Code CSA B149.1-00.

### Changing Orifices

**⚠ WARNING**

**ELECTRICAL SHOCK, FIRE AND/OR EXPLOSION HAZARD**

Failure to follow this warning could result in property damage, personal injury, and/or death.

Shut off electric power at unit disconnect or service panel and shut off gas at manual shut off valve before beginning the following procedure.

Changing orifices requires a qualified service technician.

1. Shut **OFF** gas at manual shut off valve.

2. Shut **OFF** electric power at unit disconnect or service panel. If unit is still running, allow 2.5 minutes after gas shut off before turning off power.
3. Disconnect the wires from the gas valve and disconnect pilot tubing from valve.
4. Remove the four screws holding the manifold to the manifold brackets.
5. Carefully remove the manifold with the gas valve attached.
6. Remove the orifices from the manifold with a  $\frac{7}{16}$ " box end or socket wrench.
7. Check to be sure that the size of each orifice is correct for the Btu input desired.

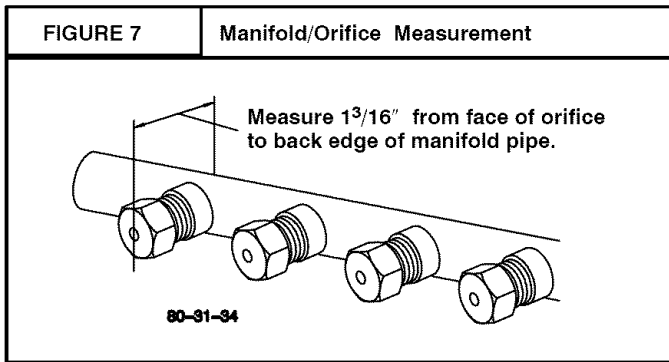

8. Install the correct orifices. Gauge the size of the orifices with a new twist drill bit of the correct size.

Make sure that the orifices go in straight so that they form a right angle (90°) to the manifold pipe.

Tighten the orifices so that there is a 1<sup>3</sup>/<sub>16</sub>" distance between the faces of the orifices to the back of the manifold pipe.

Measure the distance with a set of calipers. If you do not have a calipers, you can use an adjustable wrench and measure between the face of the jaws.

9. Reassemble in reverse order.

## 7. ELECTRICAL WIRING

**⚠ WARNING**

**ELECTRICAL SHOCK HAZARD.**

Failure to follow this warning could result in property damage, personal injury, and/or death.

Disconnect power at fuse box or service panel before making any electrical connections.  
Unit **MUST** be grounded to electrical service panel.

**NOTE:** All electrical work **MUST** conform with the requirements of local codes and ordinances and the National Electrical Code ANSI/NFPA-No. 70-1990 or current edition. Provide line voltage power supply from a separate fused circuit with a disconnect switch located within sight of the unit.

For access, remove the burner access panel. See **FIGURE 1** for access panel location. Wiring **MUST** be protected from possible mechanical damage.

### Line Voltage Wiring

Connections for line voltage are made in the unit control box area. For access, remove the burner access panel.

### Ground Connections

Do **NOT** complete line voltage connections until unit is permanently grounded. All line voltage connections and the ground connection **MUST** be made with copper wire.

A ground lug is installed in the control box area for the ground connection. Use a copper conductor of the appropriate size from the unit to a grounded connection in the electrical service panel or a properly driven and electrically grounded ground rod. See warning above.

### Line Connections

Complete the line service connections to the contactor 'L' terminals inside the control box area. Refer to applicable wiring diagram. Check all screw terminals to ensure they are tight.

### THERMOSTAT/HEAT ANTICIPATOR

The location of the thermostat has an important effect on the operation of the unit. **FOLLOW THE INSTRUCTIONS INCLUDED WITH THE THERMOSTAT FOR CORRECT MOUNTING AND WIRING.**

Set the thermostat heat anticipator in accordance with thermostat instructions.

### Final Electrical Check

1. Make a final wiring check to be sure system is correctly wired. Inspect field installed wiring and the routing to ensure that rubbing or chafing due to vibration will not occur.

**NOTE:** Wiring **MUST** be installed so it is protected from possible mechanical damage.

## 8. DUCTWORK

Maximum recommended velocity in trunk ducts is 1000 feet per minute. Velocity in branches should not exceed 800 feet per minute.

| FIGURE 8  | Capacities Air Delivery       |  |   |                   |  |
|-----------|-------------------------------|--|---|-------------------|--|
|           | Nominal Tons Air Conditioning | Nominal Air Flow Cubic Feet per Minute | Recommended Filter Sizes<br>Sq. In. Surface Area/Nominal Size |                   | Unit Size Heating Input<br>1000 x Btuh |
|           |                               |  | Disposable Filters  | Cleanable Filters |  |
| Up Thru 2 | 800-900                       | 400 or 20 x 25                         | 246 or 15 x 20  | 40 and 60         |  |
| 2 1/2     | 900-1100                      | 487 or 20 x 30                         | 301 or 14 x 25  | 60 and 80         |  |
| 3         | 1100-1300                     | 576 or 14 x 25 (2Req.)                 | 356 or 16 x 25  | 60, 80 and 100    |  |
| 3 1/2     | 1300-1500                     | 665 or 16 x 25 (2Req.)                 | 411 or 20 x25 (2Req.)   | 80 and 100        |  |
| 4         | 1500-1700                     | 753 or 20 x 25 (2 Req.)                | 466 or 20 x 25  | 80 and 120        |  |
| 5         | 1900-2100                     | 960 or 20 x 30 (2 Req.)                | 575 or 24 x 25  | 100 and 140       |  |

Minimum recommended filter areas are based on a velocity of 325 ft./min. for disposable filters and 525 ft./min. for high velocity filters (washable).

**NOTE:** Ductwork sizing affects temperature rise and cooling temperature differential. Be sure to properly size ductwork to the capacity and airflow characteristics of your unit. Failure to do so can affect limit controls, compressors,

motors, and other components and will lead to premature failure of components. This will also adversely affect day to day unit performance. Refer to rating plate and *Temperature Rise Check*.

## Combustion Blower Pipe Installation

Remove the combustion blower pipe from the right corner of burner compartment and position the end of the pipe with the screw hole over the opening of the combustion blower. The other end of the pipe should now be aligned through the opening in the side panel of unit. The pipe should slightly protude through the opening in the side panel.

Remove (1) chisle pointed #10 screw (self drilling) taped to the vent cap. Position the screw to the hole in the pipe and drill through the combustion blower outlet securing the pipe to the combustion blower.

## Ductwork Insulation

Ductwork installed outdoors should have a minimum of 2" fiberglass insulation and a weatherproof vapor barrier. It should be protected against damage. Caulking and flashings, or other means adequate to provide a permanent weather seal, should be used.

Ductwork installed in attics or other areas exposed to outside temperatures should be installed with a minimum of 2" fiberglass insulation and have an indoor type vapor barrier.

## Ductwork Connections

The use of flexible, **non-combustible** connectors between main trunk ducts and supply and return air plenums is recommended to minimize vibration transmission .

**NOTE:** Connect supply and return air plenums to unit in a manner that will allow the top of the unit to be removed without removing plenums. Plenums **MUST** be individually sealed to unit casing with ducts terminating inside structure.

## FILTERS

All return air **MUST** pass through a filter before entering the unit. An electronic air cleaner, optional filter racks, or other accessible filter arrangement **MUST** be installed in the *return* air ductwork. Minimum recommended filter areas are listed in **FIGURE 8** and are based on a velocity of 325 ft/min for disposable filters and 525 ft/min for high velocity filters (washable).

### CAUTION

**DO NOT OPERATE THE UNIT WITHOUT A FILTER.**

## 9. START-UP PROCEDURES

### ⚠ **WARNING**

**FIRE AND/OR EXPLOSION HAZARD**

Failure to follow this warning could result in property damage, personal injury, and/or death.

Do **NOT** attempt to light the pilot or burner with a match or flame of any kind.

## CHECK BEFORE STARTING

1. Check that the blower motor speed terminal block is running the correct heating and cooling speeds.
2. Check to see that clean, properly sized air filters are installed.
3. Replace all service access panels.

## Reverse Rotation (Scroll Compressors Only)

Three phase scroll compressor equipped units **CAN** run in reverse if improperly wired. If the compressor makes an unusually loud noise, or if high and low side pressures are nearly identical, this indicates reverse rotation. To correct, reverse any two wires at line voltage connections **ONLY**. Do **NOT** re-wire any circuits inside the unit to attempt correction of reverse rotation.

## Manifold Gas Pressure Adjustment

**NOTE:** Make adjustment to manifold pressure with burners operating.

### ⚠ **WARNING**

**FIRE OR EXPLOSION HAZARD.**

Failure to properly seal duct could result in personal injury and/or death.

Turn OFF gas at shut off before connecting U-tube manometer.

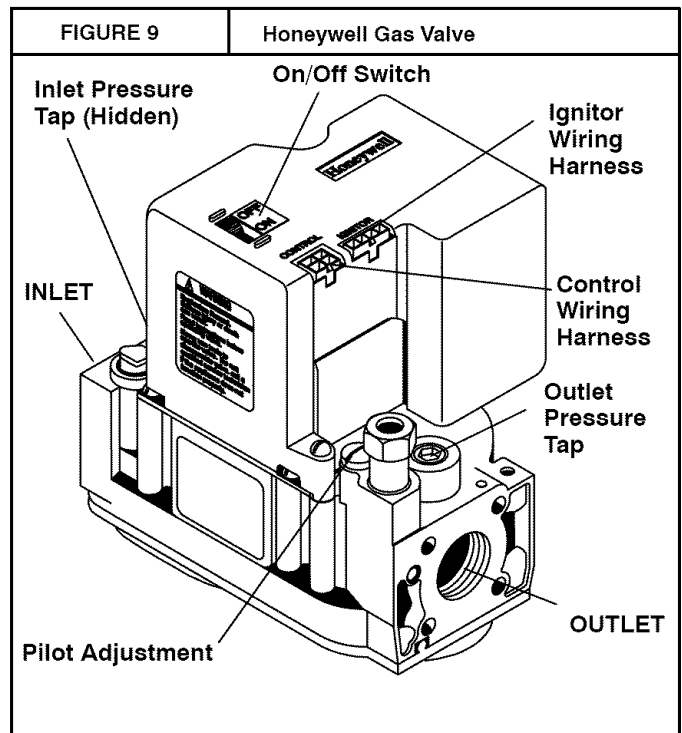

## GAS PRESSURES

1. Do **NOT** allow gas supply pressure to fall below the listed minimums. Doing so will decrease input to furnace. Refer to **FIGURE 10** for gas supply pressures.
2. Gas input **MUST NOT** exceed rated input shown on rating plate.
3. Do **NOT** allow pressures to exceed the maximum limits as listed in **FIGURE 10**.



| FIGURE 10         | Gas Pressures       |                    |
|-------------------|---------------------|--------------------|
|                   | Natural Gas         | LP Gas             |
| Minimum Inlet     | 4.5" W.C. (1120 Pa) | 11" W.C. (2740 Pa) |
| Recommended Inlet | 7" W.C. (1740 Pa)   | 11" W.C. (2740 Pa) |
| Maximum Inlet     | 13" W.C. (3230 Pa)  | 13" W.C. (3230 Pa) |
| Manifold Pressure | 3.5" W.C. (870 Pa)  | 10" W.C. (2490 Pa) |

### Manifold Pressures

Manifold pressures are covered in the startup procedure section. Refer to **Chapter 9 Start-Up Procedures**.

1. With gas **OFF**, Connect U-Tube manometer to tapped opening on gas valve. Use manometer with a 0 to 12 inches water column range.

| FIGURE 11 | Manifold Pressure Settings       |
|-----------|----------------------------------|
| Gas Type  | Manifold Pressure                |
| Natural   | 3.5 Inches Water Column (870 Pa) |
| Propane   | 10 Inches Water Column (2490 Pa) |

2. Turn gas **ON** and remove adjustment screw cover on gas valve. Turn counterclockwise to decrease pressure and clockwise to increase.

**NOTE:** Adjustment screw cover **MUST** be placed on gas valve before reading manifold pressure and operating furnace.

**⚠ WARNING**

**FIRE AND/OR EXPLOSION HAZARD**

Failure to properly set input pressure could result in property damage, personal injury and/or death.

Do NOT adjust manifold pressure more than  $\pm 0.3$  inches water column to obtain rated input.

3. Set pressure to value shown in **FIGURE 11**,  $\pm 0.07$ kPa (0.3 inches) water column. Pressure is also listed on furnace rating plate. In **NO** case should final manifold pressure vary more than  $\pm 0.07$ kPa (0.3 inches) water column.

### CIRCULATING AIR BLOWER

Check the unit's operation as outlined in the following instructions. If any unusual sparking, odors or unusual noises are encountered, shut off electric power immediately. Recheck for wiring errors, or obstructions in or near blower motors.

1. Set thermostat Heat-Cool selector to **OFF**.
2. Set thermostat fan switch to **AUTO**.
3. Turn electric power **ON**. Nothing should start running.
4. Turn manual gas valve **ON**.
5. Turn gas control valve **ON**.
6. Set thermostat fan switch to **ON**.
7. Reset thermostat fan switch to **AUTO**.

### HEATING START-UP PROCEDURE

1. Adjust thermostat setting above room temperature and set thermostat selector to **HEAT**. The combustion air blower should come **ON**.
2. The ignitor should begin to glow and pilot flame should light. Refer to Lighting/Operating Instructions label located on Burner Access Panel of unit.

**NOTE:** On a call for heat the ignitor and pilot valve will remain energized until a flame is detected by the flame sensor. It may take several minutes to purge the air out of the gas lines at initial start-up of the unit.

3. Once the flame sensor detects that a flame is present, the hot surface ignitor will de-energize and the main burners will light from the pilot.
4. 30 seconds after the burners light, the circulating blower should begin to run.

**⚠ WARNING**

**FIRE AND/OR EXPLOSION HAZARD**

Failure to follow this warning could result in property damage, personal injury, and/or death.

Do NOT attempt to light the pilot or burner with a match or flame of any kind.

### Temperature Rise Check

**NOTE:** Air temperature rise is the temperature difference between supply and return air. With a properly designed distribution system, the proper amount of temperature rise will normally be obtained when the unit is operating at rated input with the recommended blower speed.

1. The temperature rise must be within the specifications marked on the unit rating plate.

To check the temperature rise through the unit, place thermometers in the supply and return air ducts as close to the unit as possible.

Open **ALL** registers and duct dampers. Operate unit **AT LEAST** 15 minutes before taking readings.

If the correct amount of temperature rise is not obtained when operating on the recommended blower speed, it may be necessary to change the blower speed. A faster blower speed will decrease the temperature rise. A slower blower speed will increase the temperature rise.

**NOTE:** The blower speed **MUST** be set to give the correct air temperature rise through the furnace as marked on the rating plate. See **FIGURE 13** for more information.

2. After 15 minutes of operation check the limit control function by blocking the return air grille(s).

After several minutes the main burners and pilot should go **OFF**. The circulating air blower should continue to run.

Remove air restrictions. Pilot and main burners should relight after a cool down period of a few minutes.

3. Adjust the thermostat setting below room temperature.

Pilot and main burners and combustion air blower should go **OFF**.

The circulating air blower should continue to run for 60, 100, 140 or 180 seconds. This time is adjustable. See **FIGURE 12** for more information.

- Set thermostat Heat-Cool selector to **OFF**.

### FAN CONTROL CHECK

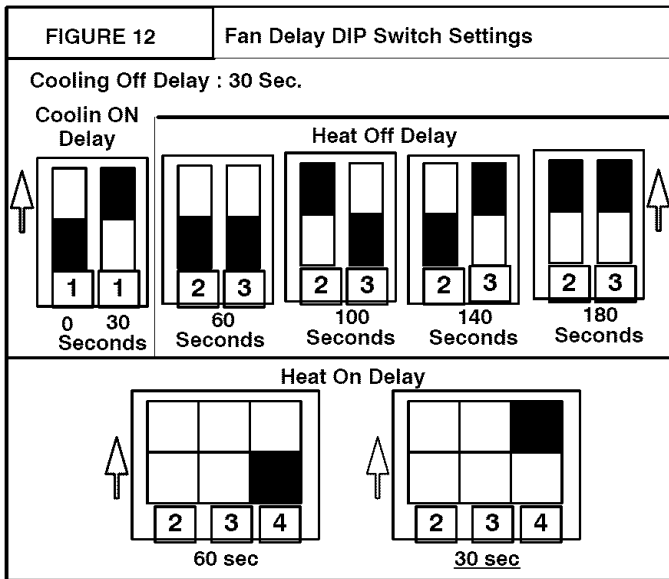

The Fan Control has adjustable settings for the circulating air blower to delay it "ON" and "OFF".

- The "ON" delay is factory pre-set at 30 seconds. It can be adjusted to 60 seconds.
- The "OFF" delay is factory preset at 140 seconds. It can be adjusted to 60, 100 and 180 seconds, respectively.

Refer to **FIGURE 12** for proper DIP switch settings.

- Operate the furnace and ensure that the blower turns **ON** and **OFF** at the appropriate time to provide the desired comfort level.

### SPEED TAPS

After determining necessary CFM and speed tap data, follow the steps below to change speeds.

- Refer to **FIGURE 13** and locate the speed tap block on blower motor.
- The yellow lead **MUST** always be connected to the speed tap block at the common quick connect terminal. The terminal is identified as **COM**. Also, this is the only lead which is  $\frac{3}{16}$ " wide. All other quick connects are  $\frac{1}{4}$ " wide.
- If it has been determined that cooling and heating speeds are needed on the same speed tap, remove the red heating lead from the speed tap block and connect it

to the insulated male terminal on the black cooling lead. Then place the insulated black female quick connect to the required speed tap.

### CONTINUOUS FAN OPERATION

An optional terminal may be provided on the electronic fan control located in the electrical control box area for operation of the continuous fan option. This connection is intended for the low speed motor tap, and has a lower contact rating (8 amps) than the heat and cool taps. When the low speed blower lead is connected to this terminal, this will provide low speed blower operation whenever the other two speeds (**Heat** or **Cool**) are not energized.

Thoroughly check the system after modification to ensure the proper operation of the circulating air blower in all modes of operation.

### Separate Speed Selections for Heat, Cool and Continuous Fan

Connect low speed lead from circulating motor to the "Cont" terminal at the electronic fan control. The appropriate motor leads should already be connected to the "Heat" and "Cool" terminals.

**Note:** See next section "Heating or Cooling and Continuous Blower Speed the Same" if low speed is required for heating to obtain desired temperature rise.

### Heating or Cooling and Continuous Blower Speed the Same

If is necessary to operate the heating or cooling speed and continuous blower speed using the same blower speed, connect a jumper between the "Heat" and "Cont" terminals on the Fan Timer Board.

**Note:** There should be only **ONE** motor lead going to the "Heat" and "Cont" terminals.

### COOLING

- Turn electric power **OFF**
- Set thermostat Heat-Cool select to **COOL**.
- Adjust thermostat setting to below room temperature.
- Turn power **ON**, for approximately one minute, then **OFF**. During power application check the following:
  - Contactor - Contacts Closing
  - Compressor - **ON**
  - Condenser fan motor - **ON**
  - Circulating Air Blower - **ON** 0 or 30 second delay
- Turn power **OFF**, check the following:
  - Contactor contacts opening.
  - Compressor - **OFF**
  - Condenser fan motor - **OFF**
  - Circulating blower - **OFF** after a 30 second delay.

FIGURE 13

Blower Motor Speed Taps (3-Speed and 4-Speed Motors)

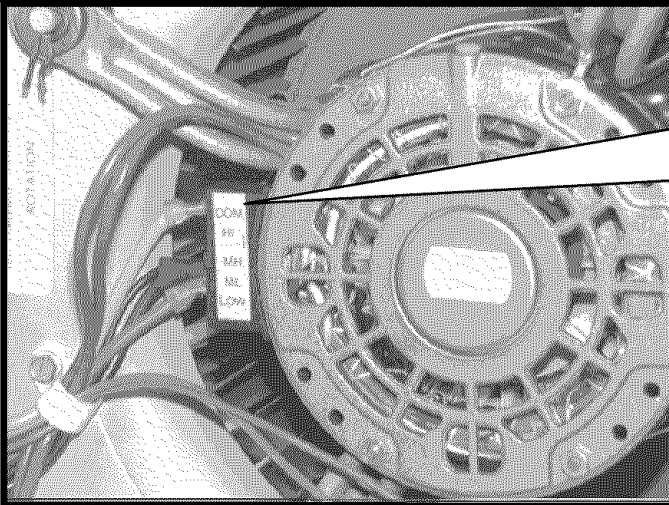

**BE SURE TO CHECK BLOWER MOTOR SPEED DATA IN UNITS TECHNICAL INFORMATION LABEL ON THE UNIT**

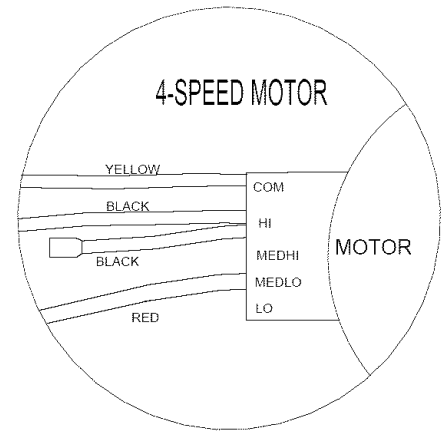
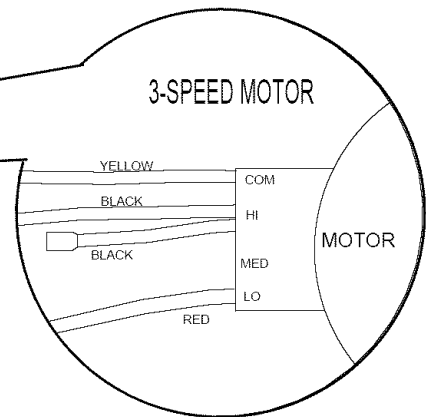

**10. OPERATION**

**⚠ WARNING**  
**ELECTRICAL SHOCK HAZARD.**  
 Failure to follow this warning could result in property damage, personal injury, and/or death.  
 Turn off electric power supply at disconnect switch or service panel before removing any access or service panel from unit.

**COMBUSTION/INDOOR FAN CONTROL**

All functions of the combustion and indoor blower are controlled by the fan control module.

**On a call for heat:**

The fan control energizes the combustion blower. Once the combustion air proving switch closes, the ignition sequence begins. The fan control will sense when the main operator of gas valve has been energized thereby firing the burners and starting the "delay on" timing sequence of the indoor blower.

**NOTE:** If the control senses that one of the safety limits has opened, the combustion and indoor fans will operate until the limit resets.

**On a call for cooling:**

The fan control starts the indoor blower at 0 or 30 seconds.

Once the thermostat is satisfied, the fan control will operate the blower for 30 additional seconds.

**11. MAINTENANCE**

**MONTHLY MAINTENANCE AND INSPECTION CHECKS**

**Air Filters**

**CAUTION**

**Do NOT operate without air filters.**

Inspect filters at least monthly and replace or clean as required. Washable filters may be cleaned by soaking in mild detergent and rinsing with cold water. Replace filters with the arrows on the side pointing in the direction of air flow. Dirty filters are the most common cause of inadequate heating or cooling performance, and of compressor failures.

**HEATING SEASON CHECKS (MONTHLY)**

**Pilot Flame**

While the main burner is on, the flame should envelop the upper part of the flame sensor.

**Main Burner Flame**

Flames should be stable and solid blue, (dust may cause orange tips or they may have wisps of yellow, but they **MUST** not have solid yellow tips). They should extend directly into the heat exchanger tubes and the turbulators

should glow orange (after about five minutes of operation). Main burner flame should be inspected monthly.

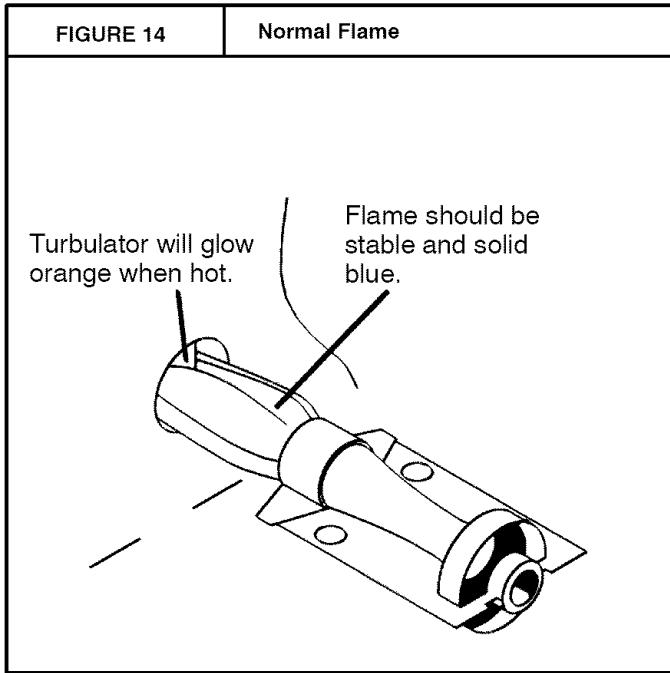

Using a light and mirror (as required) inspect the inside of the vent hood and the inlet air opening in the burner compartment. Look for soot and severe rust or corrosion and any obstructions due to leaves, spiderwebs, etc. Clean as required.

**COOLING SEASON CHECKS (MONTHLY)**

**Condenser Coil**

Keep the condenser inlet and outlet area clean and free of leaves, grass clippings or other debris. Grass should be kept short in front of the condenser inlet. Shrubbery **MUST** be trimmed back so it is no closer than 30 inches to unit.

**Condensate Drain**

Check for condensate drainage. Clean as required.

**ANNUAL MAINTENANCE AND INSPECTION**

|   |
|---|
| <p><b>⚠ WARNING</b></p>   |
| <p><b>ELECTRICAL SHOCK HAZARD.</b></p> <p>Failure to follow this warning could result in property damage, personal injury, and/or death.</p> <p>Turn off electric power supply at disconnect switch or service panel before removing any access or service panel from unit.</p> |

The annual inspection should include lubrication and cleaning as required to ensure efficient operation of the unit. To simplify access, remove all access panels and the top from the unit if possible .

**Condenser Fan Motor**

Oil the condenser fan motor after five years of operation and every five years thereafter, if applicable.

**VENT ASSEMBLY**

|   |
|---|
| <p><b>⚠ WARNING</b></p>   |
| <p><b>BURN HAZARD.</b></p> <p>Failure to follow this warning could result in property damage or personal injury.</p> <p>Flue cover may be hot! Allow adequate time for flue cover to cool</p> |

Use SAE 10W30 motor oil. To oil, remove the hole plugs from the motor end bells and add several drops (approximately 1/2 teaspoonful) of oil with a squeeze type, flexible tube oiler. Replace hole plugs after oiling. Do not over oil.

Clean the surrounding area and the condenser and evaporator coils. Use caution to avoid damage to coil fins.

**BLOWER MOTOR ACCESS**

Refer to **Figure 15** for a view of blower motor and compartment.

1. Remove the blower access panel
2. Remove the three screws securing the blower motor housing. If unit has a support bracket, remove the two screws securing the bracket.
3. Remove the two red wires attached to the limit switch and remove the limit switch.

**Motor removal and replacement**

This method is required to replace or repair blower wheel, blower housing, or any unreachable components behind blower assembly.

1. Remove all screws around rim of unit top, (except screws which are inaccessible because of proximity to structure).
2. Raise unit top at corner of unit closest to blower at least 2" and place a sturdy brace at least 2" thick between top and unit corner. See **FIGURE 15**. A 2X4 piece of wood is ideal for this.
3. Disconnect all wires from housing and slide housing out of unit. Reverse this process to reinstall.

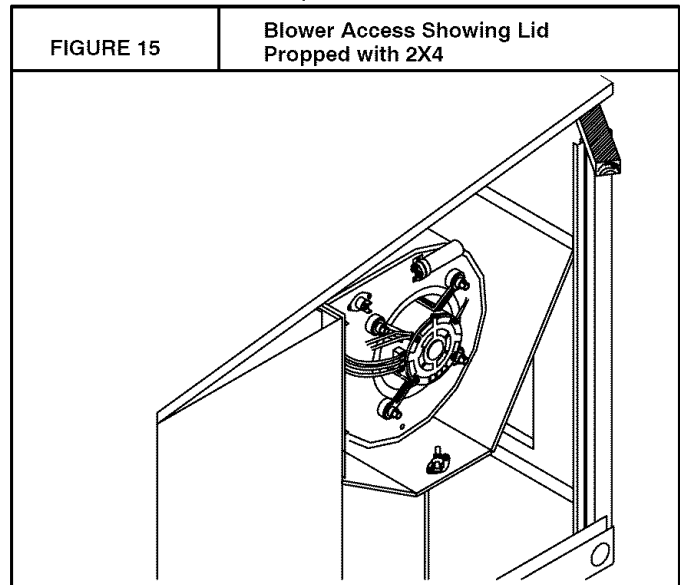

## Circulating Air Blower

Visually inspect the blower wheel for accumulations of dirt or lint. Clean the compartment and the blower wheel. If accumulation is excessive on blower wheel, or does not easily remove, it will be necessary to remove the blower assembly.

Oil the blower motor, if applicable, by adding  $\frac{1}{2}$  teaspoonful (1cc) of SAE 10W30 to each motor bearing. The blower motor should be oiled after five years of operation and every five years thereafter.



## CAUTION

**Do not use 3 in 1 oil, penetrating oil, WD40 or similar oils to oil motor bearings.**

## Burners / Heat Exchangers / Flue Gas Passages

To inspect the burners, heat exchanger and interior flue gas passages, use a light and small mirror on an extension handle.

Check the exterior of the heat exchanger and the interior flue gas passages for any evidence of deterioration due to corrosion, cracking or other causes. If signs of scaling or sooting exist, remove the burners and clean the heat exchanger, as required.

## INSPECTION AND CLEANING OF BURNER ASSEMBLY/HEAT EXCHANGERS/FLUE GAS PASSAGES

### For Qualified Service Technician Only

See **FIGURE 16** for identification of parts.

1. Disconnect electrical power to unit.
2. Turn **OFF** gas at manual shut off valve.
3. Remove burner access panel.
4. Remove the vent assembly flue pipe.
5. Disconnect gas pipe at union.
6. Disconnect wires from gas valve, note connections.
7. Remove screws that secure the flame shield and remove gas control valve, manifold and burners as an assembly.
8. Remove collector box, injector plate, and restrictor plate, including gaskets.
9. Hold the burner assembly vertically and lightly tap it against a wood block. Clean also with a stiff brush. Severe cases of lint clogging may require washing the burners in hot water.
10. Clean flue gas passages by using small brushes and a vacuum cleaner. It may be necessary to fabricate handle extensions for the brushes to reach the areas that require cleaning. Reinspect after cleaning and replace the heat exchanger if defective.
11. Reinstall parts and gaskets in reverse order. On spark to pilot models check the spark gap.  $\frac{1}{8}$  inch is required between the igniter and pilot hood.
12. Turn gas on and check for leaks.
13. Install all access panels, turn power on and check for normal operation.

FIGURE 16

Access to Burners

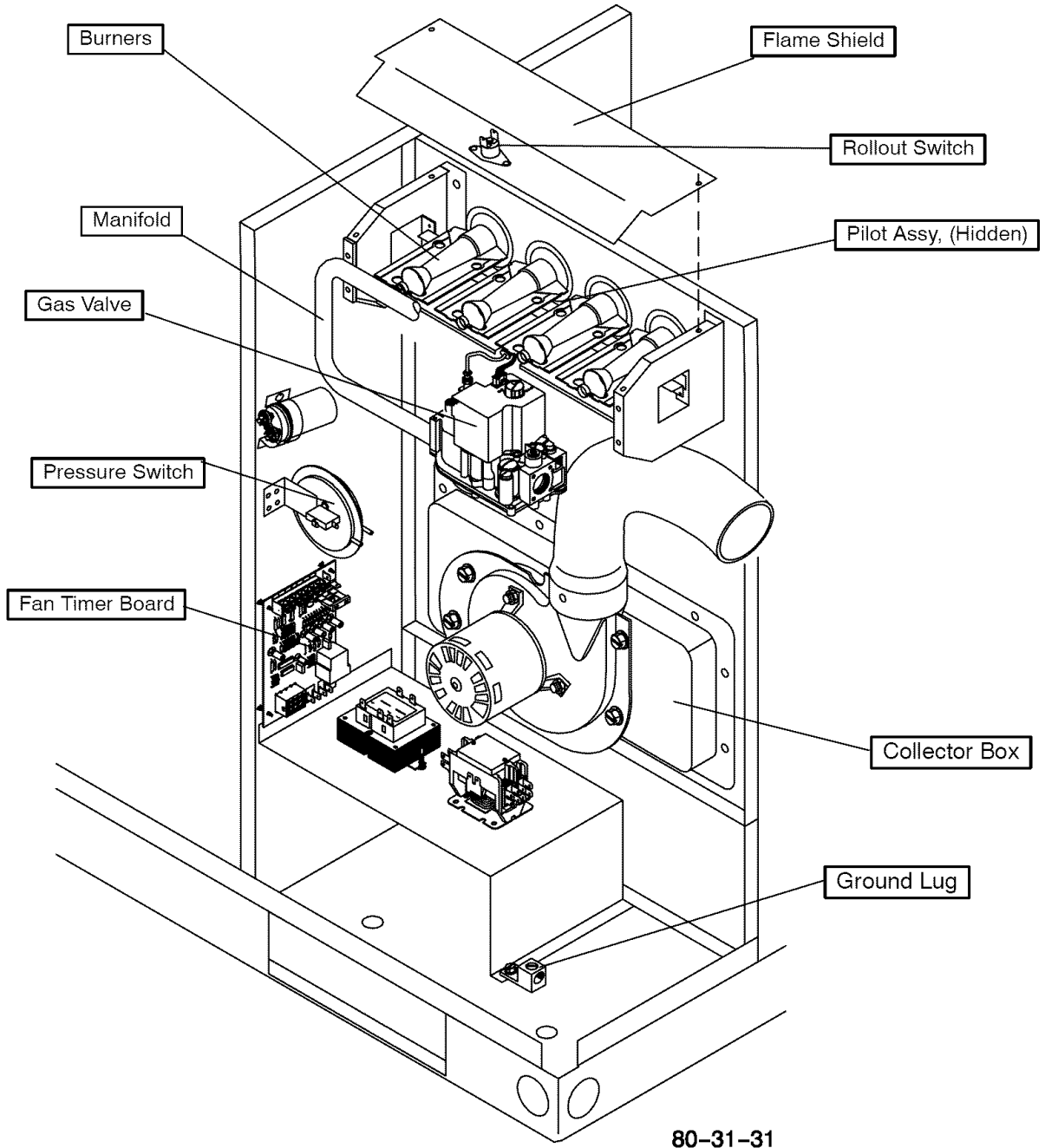

Pilot Assembly

# RIGGING INSTRUCTIONS

1096286



## WARNING

FAILURE TO FOLLOW THESE INSTRUCTIONS CAN RESULT IN PROPERTY DAMAGE, BODILY INJURY OR DEATH.

- ALL PANELS MUST BE IN PLACE WHEN RIGGING AND LIFTING.
- HOOK RIGGING SHACKLES THROUGH HOLES IN BASE RAIL, AS SHOWN IN DETAIL-A.
- USE SPREADER BARS, WHEN RIGGING, TO PREVENT UNIT DAMAGE.
- BE SURE RIGGING AND SHACKLES ARE SUFFICIENT TO HANDLE WEIGHT LISTED BELOW.

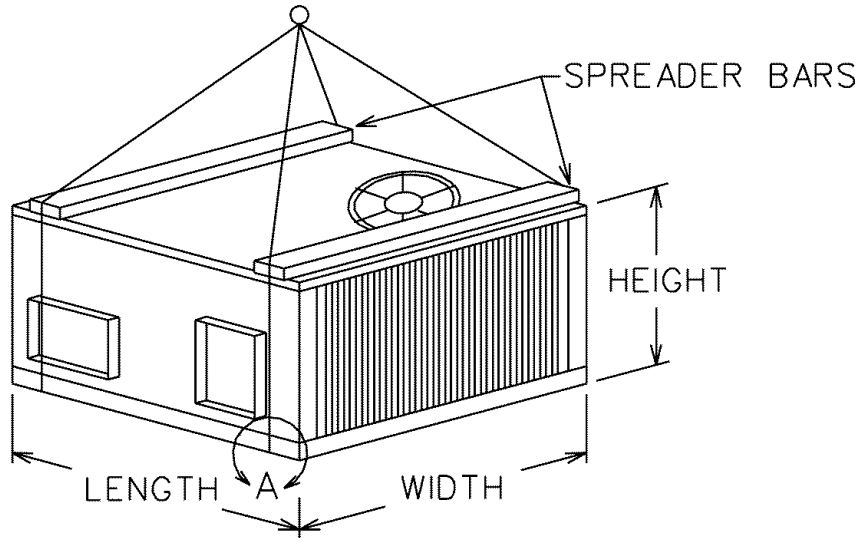

### DETAIL - A

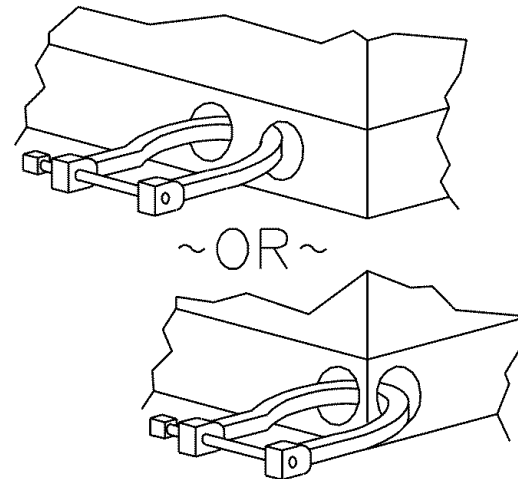

| CABINET | MAX. LENGTH |      | MAX. WIDTH |      | MAX. HEIGHT |     | MAX. WEIGHT |     |
|---------|-------------|------|------------|------|-------------|-----|-------------|-----|
|         | IN          | MM   | IN         | MM   | IN          | MM  | LB          | KG  |
| SMALL   | 52.00       | 1219 | 48.00      | 1219 | 38.00       | 965 | 500         | 227 |
| LARGE   | 73.00       | 1854 | 48.00      | 1219 | 38.00       | 965 | 900         | 409 |