

INSTALLATION INSTRUCTIONS

TXV Coils

EBD, EBA

These instructions must be read and understood completely before attempting installation.

It is important that the Blower and Duct System be properly sized to allow the system to operate at full capacity. Poorly designed systems will not give satisfactory cooling or economy. They may even shorten the service life of the compressor in the outdoor unit.

Safety Labeling and Signal Words

DANGER, WARNING, CAUTION, and NOTE

The signal words **DANGER**, **WARNING**, **CAUTION**, and **NOTE** are used to identify levels of hazard seriousness. The signal word **DANGER** is only used on product labels to signify an immediate hazard. The signal words **WARNING**, **CAUTION**, and **NOTE** will be used on product labels and throughout this manual and other manuals that may apply to the product.

DANGER – Immediate hazards which **will** result in severe personal injury or death.

WARNING – Hazards or unsafe practices which **could** result in severe personal injury or death.

CAUTION – Hazards or unsafe practices which **may** result in minor personal injury or product or property damage.

NOTE – Used to highlight suggestions which **will** result in enhanced installation, reliability, or operation.

Signal Words in Manuals

The signal word **WARNING** is used throughout this manual in the following manner:



The signal word **CAUTION** is used throughout this manual in the following manner:



Signal Words on Product Labeling

Signal words are used in combination with colors and/or pictures on product labels.

TABLE OF CONTENTS

Installation	2 – 3
Condensate Drain	3
Waste Line Connection	4
Refrigerant Line Connections	4 – 5
Refrigerant Metering Device	5
Check and Adjust Airflow	5 – 6
Start-Up Procedure	6

ELECTRICAL SHOCK HAZARD

Failure to turn off electric power could result in personal injury or death.

Before installing or servicing system, turn off main power to the system. There may be more than one disconnect switch, including accessory heater(s).

INSTALLATION

EBA and EBD Coils are designed for Upflow application only (refer to Figures 3 & 4). Using these coils in other configurations may result in excessive water blow-off.

EBA Loose Coils are shipped with a metal collar plate approximately the same size as the drain pan. The collar plate must be installed between the drain pan and the furnace or air handler cabinet to prevent condensation inside the cabinet. Position the collar plate as shown in Figure 1, with the flanges pointing down, towards the furnace or air handler cabinet. Size the plenum or fabricate spacers to seal against the outside of the collar and prevent air bypass.

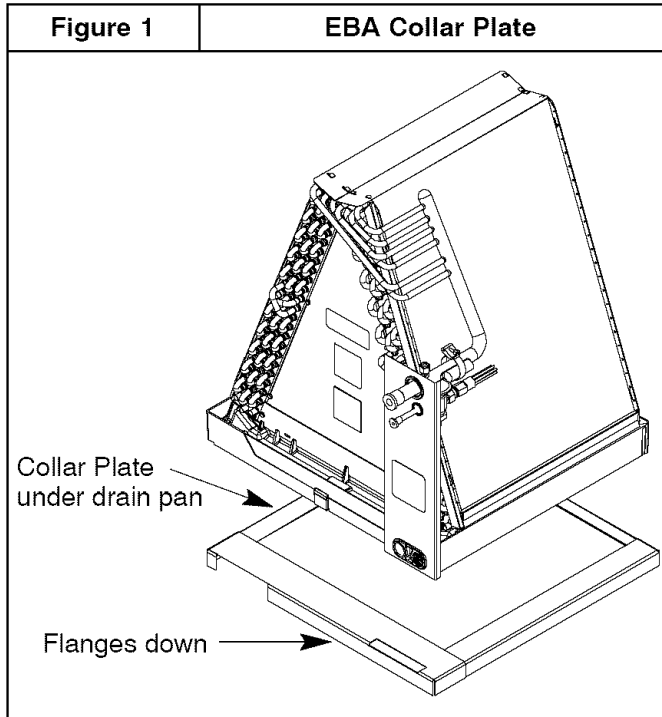

EBD Cased Coils are designed to fit furnaces and air handlers of the same width with no modifications. When an EBD Cased Coil is applied to a narrower or wider furnace or air handler, a field fabricated adapter is required. Refer to Figure 2 for examples of field fabricated adapters.

⚠ CAUTION

PRODUCT DAMAGE HAZARD

Failure to follow this caution may result in product damage.

When a narrower coil is installed on a wider gas furnace (upflow, downflow, or horizontal), a field fabricated adapter must create 3" minimum space between furnace and coil to allow airflow to distribute evenly.

When a loose coil is installed on any GAS furnace, the drain pan must be at least 2" away from the furnace heat exchanger to avoid drain pan damage.

When a loose coil is installed on any OIL furnace, the drain pan must be at least 5" away from the furnace heat exchanger to avoid drain pan damage.

⚠ CAUTION

PROPERTY DAMAGE HAZARD

Failure to follow this caution may result in property damage

A field fabricated auxiliary drain pan, with a separate drain is **REQUIRED** for all installations over a finished living space or in any area that may be damaged by overflow from a restricted main drain pan. In some localities, local codes require an auxiliary drain pan for **ANY** horizontal installation.

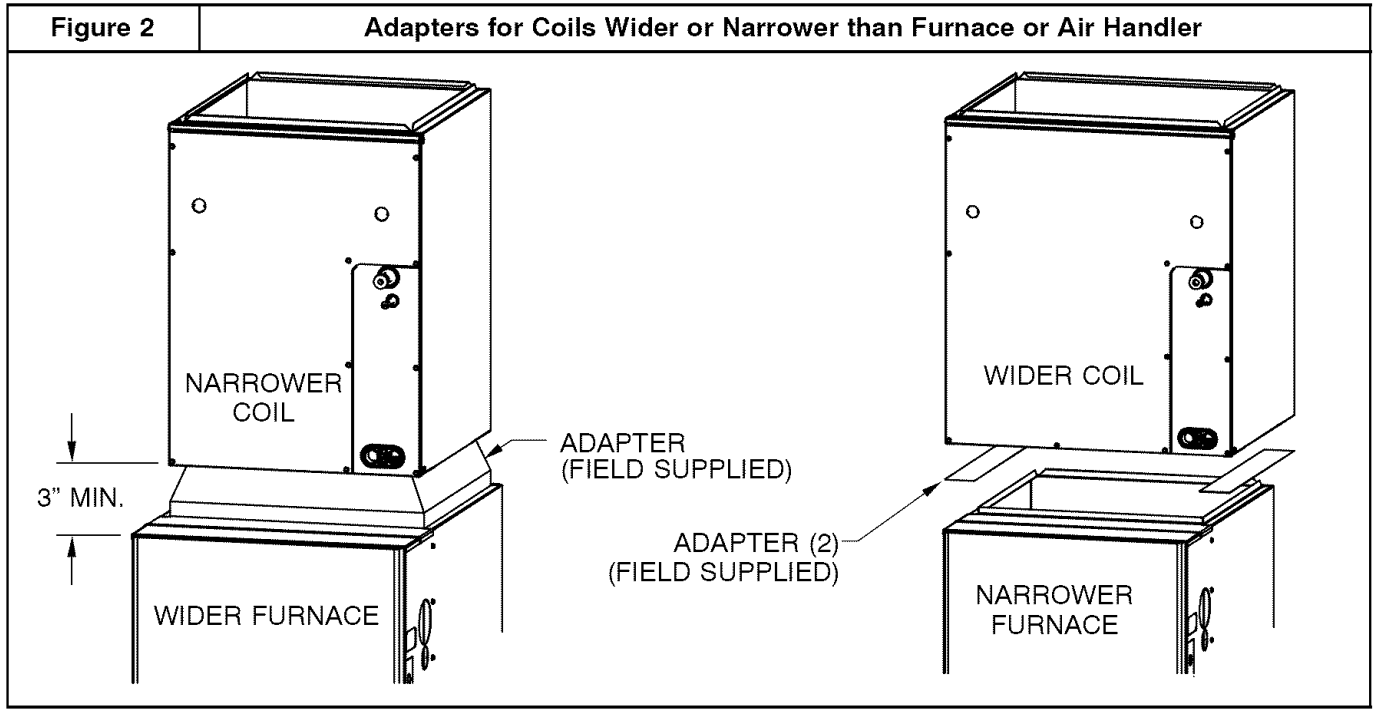

NOTE: When coil is used in a heat pump application with electric heat, coil must be installed upstream of the electric heater (refer to Figure 3). This prevents electric heat from driving up refrigeration system pressure during heating cycle.

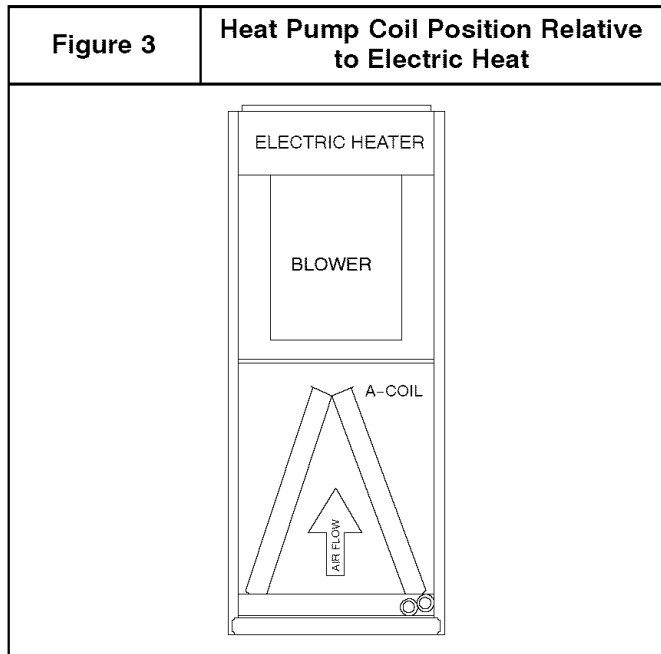

NOTE: When coil is installed with a Heat Pump in conjunction with a fossil fuel heating system, a Fossil Fuel Kit must be used. Refer to Product Specification literature for kit part number.

NOTE: When coil is installed to a gas or oil furnace, coil must be installed downstream of the furnace heat exchanger (refer to Figure 4). This reduces condensate formation in the furnace heat exchanger during the cooling cycle.

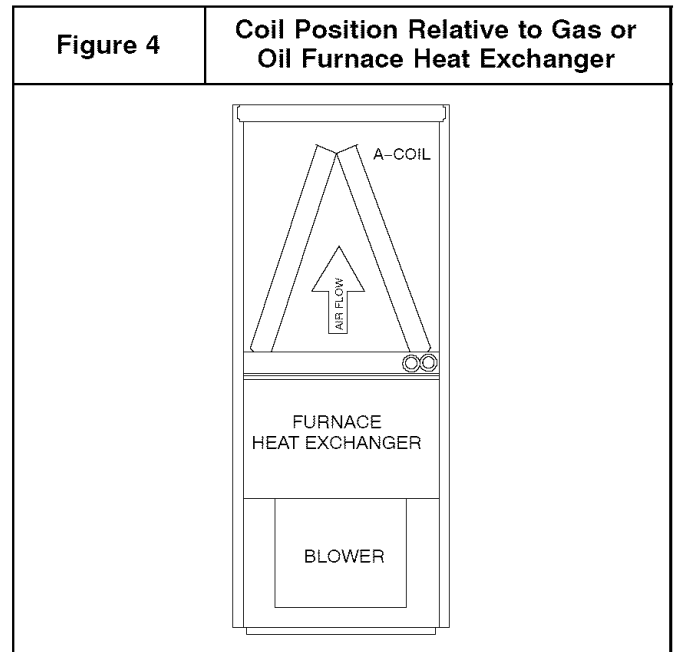

NOTE: On furnace installations where the coil is located in an unconditioned space, nuisance sweating may occur in the area around the cabinet to supply duct joint. Wrap the joint between the cabinet and the supply duct with a 6" wide piece of insulation with vapor barrier.

CONDENSATE DRAIN

Coil is provided with two 3/4" NPT condensate drain connections. The connection with the **larger internal opening is the primary drain**, and the connection with the **smaller internal opening is the secondary (overflow) drain**. Condensate drain lines should be installed in a manner that does not obstruct access to the filter. Use PVC fittings on the plastic condensate pan. Finger tighten plus 1 1/2 turns. Do not over-tighten. Use pipe dope.

If coil is located in or above a living space where damage may result from condensate overflow, a separate 3/4" drain must be provided from secondary (overflow) drain connection. Run this drain to a place in compliance with local installation codes where it will be noticed when unit is operational. Condensate flowing from secondary (overflow) drain indicates a plugged primary drain – unit requires service or water damage will occur.

1. Connect drain lines to the appropriate drain connections. Drain lines should not be smaller than the drain connections (3/4").
2. **NOTE:** Traps must be used when the coil is installed on the return air side of the system. When coil is installed on the supply side (outlet air) it is not necessary to install traps and better drainage is usually achieved without traps.

Install properly sized condensate traps in the drain lines as close to the coil as possible. Install drain lines below the bottom of the drain pan and pitch the

drain lines down from the coil at least 1/4 inch per foot of run. Horizontal runs over 15 feet long must also have an anti-siphon air vent (stand pipe), installed ahead of the horizontal run. An extremely long horizontal run may require an oversized drain line to eliminate air trapping.

Refer to Figure 5 for minimum trap dimensions.

3. Route to the outside or to a floor drain. Check local codes before connecting to a waste (sewer) line.
4. **Prime all traps**, test for leaks, and insulate drain lines where sweating could cause water damage.
5. If a gravity drain cannot be used, install a condensate pump. Install the pump as close to the indoor section as possible.

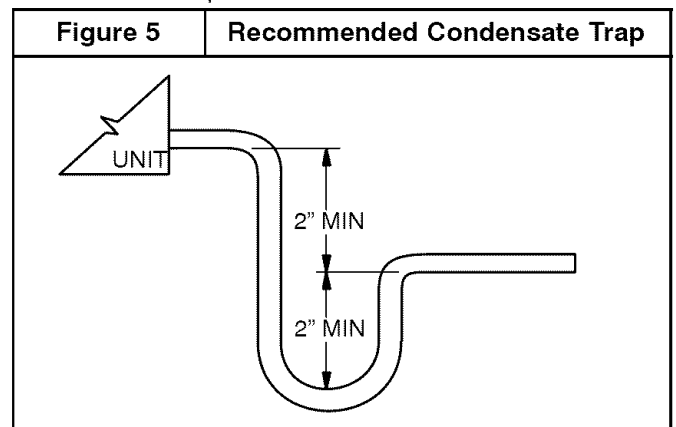

WASTE LINE CONNECTION

If the condensate line is to be connected to a waste (sewer) line, an open trap must be installed ahead of the waste line to prevent escape of sewer gases (refer to Figure 6).

⚠ WARNING

EXPLOSION HAZARD

Failure to provide trap could result in personal injury, death, or property damage.

Provide trap with air gap in drain line when connecting to waste (sewer) line. Refer to Figure 6.

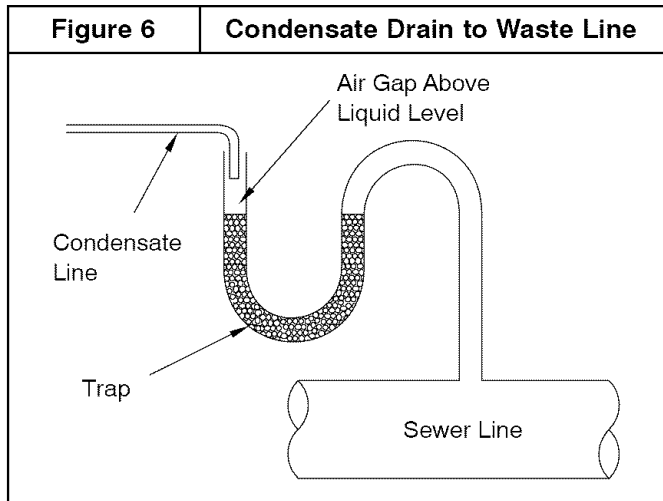

REFRIGERANT LINE CONNECTIONS

⚠ WARNING

PERSONAL INJURY HAZARD

Failure to relieve pressure in the coil could result in personal injury.

Wear eye protection.

Coil is factory charged with 15 psi nitrogen. Pierce the centers of both rubber tubing plugs to relieve pressure before removing plugs.

NOTE: Factory nitrogen charge may escape past rubber plugs during storage. This does not indicate a leaking coil nor warrant return of the coil.

Size and install refrigerant lines according to information provided with outdoor unit. Coil connection tube sizes are shown in Figure 7. Route refrigerant lines to the coil in a manner that will not obstruct service access to the unit or removal of the filter.

Figure 7 Coil Connection Tube Size (inch)

Model Size	Liquid	Suction
18 (1 ½ ton)	3/8	5/8
24 (2 ton)	3/8	5/8
30 (2 ½ ton)	3/8	3/4
36 (3 ton)	3/8	3/4
42 (4 ½ ton)	3/8	7/8
48 (4 ton)	3/8	7/8
60 (5 ton)	3/8	7/8

1. Remove cabinet door. Remove tubing plate with rubber grommets and slide plate with grommets onto the refrigerant lines (field line-set), away from braze joints.
2. Remove rubber plugs from coil stubs using a pulling and twisting motion. Hold coil stubs steady to avoid bending or distorting.
3. Wrap TXV and nearby tubing with a heat-sinking material such as a wet cloth.
4. Fit refrigerant lines into coil stubs. Wrap a heat-sinking material such as a wet cloth behind braze joints. **NOTE:** See outdoor unit Installation Instructions regarding requirements for installation of a filter-drier in the liquid line close to the indoor coil.
5. Braze using a Sil-Fos or Phos-copper alloy.
6. After brazing, allow joints to cool. Slide tubing plate with rubber grommets over joints. Position tubing at center of each grommet to ensure an air seal around the tube (refer to Figure 8).

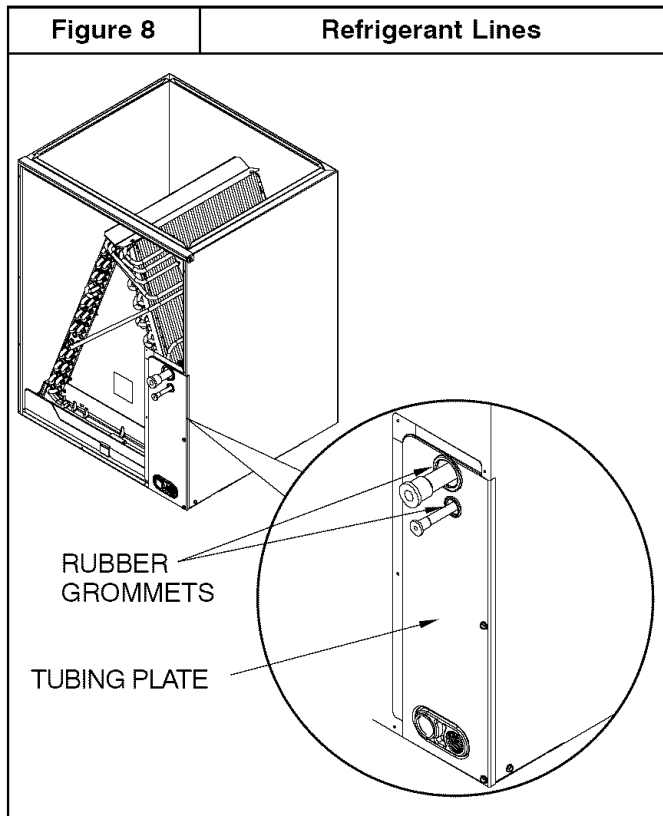

Strainer screen is factory installed inside the liquid tube stub (TXV tube). Leave the strainer screen in place during installation (refer to Figure 9).

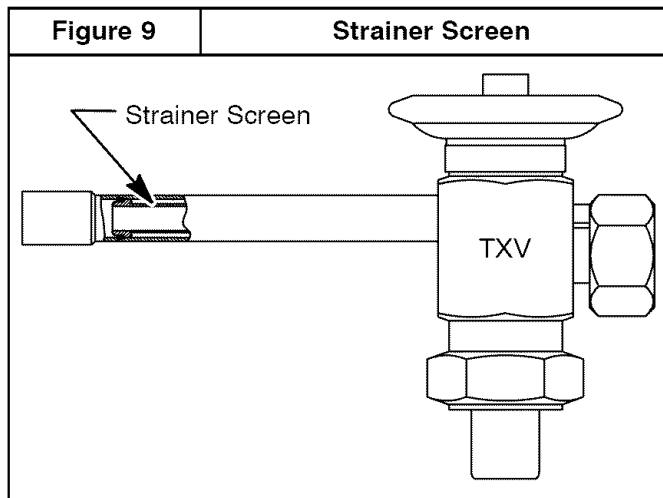

⚠ CAUTION

PRODUCT DAMAGE HAZARD

Failure to follow this caution may result in product damage.

Braze with Sil-Fos or Phos-copper alloy on copper-to-copper joints and wrap a wet cloth around rear of fitting to prevent damage to TXV.

REFRIGERANT METERING DEVICE

EBD and EBA coils have a factory installed hard shut-off TXV designed only for use with R-22 refrigerant. Use only with outdoor units designed for R-22.

TXV is factory set and not field adjustable.

⚠ CAUTION

PRODUCT DAMAGE HAZARD

Failure to follow this caution may result in product damage.

This Coil has a hard shut-off TXV metering device. A compressor Hard Start Kit is required in all applications where the matching outdoor unit has a single-phase reciprocating compressor.

CHECK AND ADJUST AIR FLOW

⚠ WARNING

ELECTRICAL SHOCK HAZARD

Failure to shut off electric power could result in personal injury or death.

Before adjusting blower speed, shut off electric power to the furnace or blower module.

It is important that the correct amount of air (CFM) flows through the coil. The installer must determine the required CFM based on the characteristics of the specific system (such as system size, ducting, components, and accessories). In general, 400 CFM per ton is the nominal required value, with a range of 350 – 450 CFM per ton.

Check Static Pressure Drop and CFM Across Coil

The amount of air (CFM) is related to a pressure drop. To determine the CFM, measure the pressure drop using an inclined manometer (sometimes called draft gauge or air flow gauge).

1. The coil should be dry and clean. The air filter must be clean and in place. All registers open. DO NOT run the outdoor unit when checking air flow.
2. Run the blower on cooling speed.

3. Using the manometer (draft gauge or flow gauge), measure the static pressure drop across the dry coil and compare it to the numbers in Figure 10.
4. Find the corresponding CFM in Figure 10.

Adjusting Air Flow

If CFM is too low, increase the blower speed and measure the static pressure drop again. Determine CFM from Figure 10.

If CFM is too high, reduce the blower speed and measure the static pressure drop again. Determine CFM from Figure 10.

NOTE: Change blower speed as shown in the instructions for the furnace or air handler.

NOTE: It may not be possible to obtain a gauge reading exactly the same as shown in Figure 10. This is due to variations in duct systems and blower speeds.

If the motor is at the highest speed and the CFM is still not high enough, replace the blower and/or motor with a larger size.

If the unit has an adjustable belt driven blower, use an ammeter to check the motor current draw. If the current draw is higher than the motor name plate amps, replace the motor with one of greater horsepower.

Figure 10		CFM and Pressure Drop						
Coil Size	CFM Across Coil	Static Pressure Drop Across Coil (Inches Water Column)		Coil Size	CFM Across Coil	Static Pressure Drop Across Coil (Inches Water Column)		
		Dry	Wet			Dry	Wet	
18B 1½ tons	500	0.096	0.106	42J 3½ tons	1200	0.129	0.137	
	600	0.127	0.140		1300	0.148	0.159	
	700	0.161	0.183		1400	0.168	0.180	
24B 2 tons	700	0.134	0.141		1500	0.189	0.203	
	800	0.166	0.176		1600	0.211	0.228	
	900	0.200	0.215		42L 3½ tons	1200	0.114	0.142
24F 2 tons	700	0.110	0.118	1300		0.130	0.161	
	800	0.134	0.146	1400		0.146	0.182	
	900	0.160	0.176	1500		0.164	0.202	
30B 2½ tons	800	0.137	0.143	48F 4 tons		1600	0.182	0.222
	900	0.169	0.174			1400	0.250	0.263
	1000	0.204	0.211		1500	0.284	0.297	
	1100	0.241	0.251		1600	0.320	0.336	
30F 2½ tons	800	0.101	0.106	48J 4 tons	1700	0.358	0.376	
	900	0.121	0.129		1800	0.398	0.418	
	1000	0.143	0.154		1400	0.192	0.196	
	1100	0.168	0.181		1500	0.219	0.225	
36B 3 tons	1000	0.188	0.202	48L 4 tons	1600	0.245	0.253	
	1100	0.224	0.240		1700	0.273	0.283	
	1200	0.262	0.281		1800	0.303	0.314	
	1300	0.303	0.325		1400	0.180	0.193	
	1400	0.349	0.374		1500	0.198	0.214	
36F 3 tons	1000	0.133	0.139	60J 5 tons	1600	0.222	0.241	
	1100	0.154	0.163		1700	0.247	0.270	
	1200	0.177	0.189		1800	0.275	0.296	
	1300	0.203	0.216		1700	0.260	0.285	
	1400	0.227	0.245		1800	0.288	0.315	
36J 3 tons	1000	0.104	0.106	60L 5 tons	1900	0.316	0.346	
	1100	0.121	0.124		2000	0.347	0.381	
	1200	0.139	0.144		2100	0.378	0.413	
	1300	0.159	0.166		2200	0.409	0.447	
	1400	0.181	0.190		1700	0.232	0.263	
					1800	0.256	0.291	
					1900	0.283	0.321	
					2000	0.308	0.354	
					2100	0.335	0.386	
					2200	0.363	0.419	

START-UP PROCEDURE

Refer to outdoor unit Installation Instructions for refrigeration system start-up instructions and refrigerant charging method details.