

# Installation Instructions and Homeowner's Manual

## WARM AIR FURNACE MULTIPOSITION

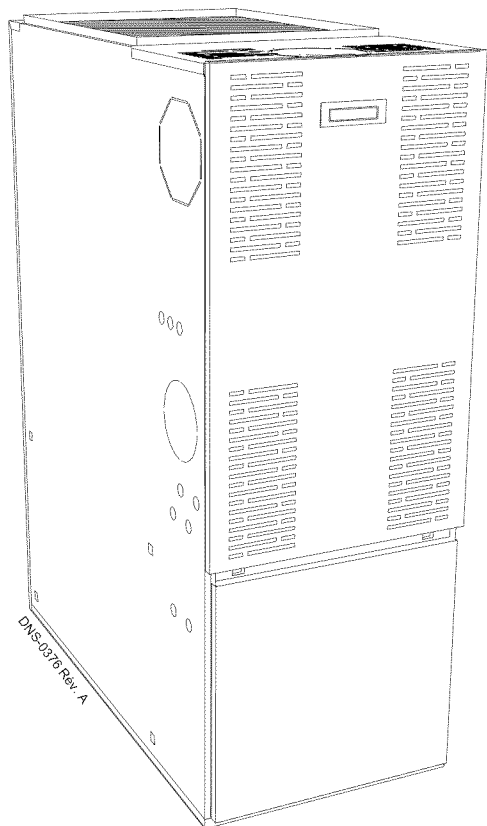

**INSTALLER / SERVICE TECHNICIAN:**

USE THE INFORMATION IN THIS MANUAL FOR THE INSTALLATION / SERVICING OF THE FURNACE AND KEEP THE DOCUMENT NEAR THE UNIT FOR FUTURE REFERENCE.

**HOMEOWNER:**

PLEASE KEEP THIS MANUAL NEAR THE FURNACE FOR FUTURE REFERENCE.

**Models:**

**AMP105-IE2**

**AMP120-IE2**

**NOMF105D12C**

**NOMF155E19C**

**NOMF106D12B**

**NOMF156E19C**



**Attention:**

Do not tamper with the unit or its controls.  
Call a qualified service technician.

Manufactured by:

UTC Canada Corporation

**ICP Division**

3400 Industrial Boulevard

Sherbrooke, Quebec - Canada

J1L 1V8

# PART 1 INSTALLATION

## FOR YOUR SAFETY

DO NOT STORE OR USE GASOLINE OR OTHER FLAMMABLE VAPOURS AND LIQUIDS IN THE VICINITY OF THIS OR ANY OTHER APPLIANCE.

DO NOT ATTEMPT TO START THE BURNER WHEN EXCESS OIL HAS ACCUMULATED, WHEN THE FURNACE IS FULL OF VAPOUR OR WHEN THE COMBUSTION CHAMBER IS VERY HOT.

## CAUTION

These instructions are intended for use by qualified personnel having been trained in installing this type of furnace. Installation of this furnace by an unqualified person may lead to equipment damage and/or hazardous conditions, which may lead to bodily harm.

### 1.1 DANGER, WARNING AND CAUTION

The words DANGER, WARNING and CAUTION are used to identify the levels of seriousness of certain hazards. It is important that you understand their meaning. You will notice these words in the manual as follows:



## DANGER

Immediate hazards which **WILL** result in death or serious bodily and/or material damage.



## WARNING

Hazards or unsafe practices which **CAN** result in death or serious bodily and/or material damage.

## CAUTION

Hazards or unsafe practices which **CAN** result in minor bodily and/or material damage.



## WARNING

For use with grade 2 Fuel Oil maximum. Do not use gasoline, crankcase oil or any oil containing gasoline!



## WARNING

Never burn garbage or paper in the heating system and never leave rags or paper around the unit.

**IMPORTANT:** Please refer to the Sealed Combustion System Manual for installation instructions. The furnace must be installed in an upflow position when used with a Sealed Combustion System.

**IMPORTANT:** All local and national code requirements governing the installation of oil burning equipment, wiring and flue connections must be followed. Some of the codes that may be applicable are:

**CSA B139** Installation Code for Oil Burning Equipment

**ANSI/NFPA 31** Installation of Oil Burning Equipment

**ANSI/NFPA 90B** Warm Air Heating and Air Conditioning Systems

**ANSI/NFPA 211** Chimneys, Fireplaces, Vents and Solid Fuel Burning Appliances

**ANSI/NFPA 70** National Electrical Code

**CSA C22.2 No.3** Canadian Electrical Code

Only the latest issues of the above codes should be used, and are available from either:

The National Fire Protection Agency  
1 Batterymarch Park  
Quincy, MA 02269

or

The Canadian Standards Association  
178 Rexdale Blvd.  
Rexdale, Ontario M9W 1R3

### 1.2 GENERAL

This central heating unit is a true multi-position unit, in that it can operate in four different configurations, i.e., upflow, counter flow (downflow), and horizontal (both left-to-right and right-to-left airflow).

Very few modifications are required during installation, to change the furnace from one configuration to another. The furnace is shipped in the upflow configuration; however, instructions on how to change to the other configurations are included in this manual.

The furnace is shipped complete with burner and controls. It requires a 115VAC line voltage connection to the control panel, thermostat hook-up as shown on the wiring diagram, one or more oil line connections, suitable ductwork and connection to a properly sized vent.

The air handling capacity of this furnace is designed for cooling as well. Please refer to Table 4, p. 14 for the expected airflow at various external static pressures.

### 1.3 LOCATION

The unit must be installed in a location where the ambient and return air temperature is over 15°C (60°F).

**WARNING**

**This furnace is not watertight and is not designed for outdoor installation. This furnace shall be installed in such a manner as to protect the electrical components from water. Outdoor installation will lead to a hazardous electrical condition and to premature furnace failure.**

**CAUTION**

If this furnace is installed in an attic, it is important to keep insulation at least 0.3 m (12") away from any furnace openings. Some types of insulating material may be combustible.

This furnace is approved for reduced clearances to combustible construction. Therefore, it may be installed in a closet or similar enclosure. As this unit may be installed as an upflow, counter flow, or horizontal furnace, it may be located in a basement, on the same level as the area to be heated, suspended, or in a crawlspace. In any case, the unit should always be installed level.

In a basement, or when installed on the floor (as in a crawlspace), it is recommended that the unit be installed on a concrete pad that is 2.5 cm to 5.0 cm (1" to 2") thick.

When installed in the counter flow position, this furnace must not be installed on combustible flooring, unless the approved sub-base is used (Model # DFB-101). Since the flue pipe is in counter flow position, be sure that the clearances from the flue pipe to combustible construction are maintained. Also, it is recommended to use the flue pipe protection kit FPG-101 or FPG-102. Please refer to the above drawing and the installation instructions included with the kit.

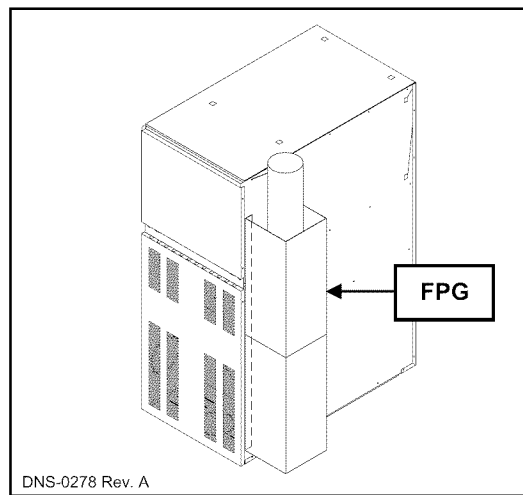

When installed in a horizontal position, the furnace may be suspended by using an angle iron frame, as long as the total weight of both the furnace and the frame are included in the calculations. Other methods of suspension are acceptable. When installed in the horizontal position, this furnace must not be installed on combustible flooring, unless the approved sub-base is used (Model # HFB-101).

**The required minimum clearances for this furnace in all positions are specified in Tables 5.1 and 5.2, p. 15 and 16.**

The furnace should be located as closely as possible to the chimney or vent in order to keep vent connections short and direct. The furnace should also be located near the centre of the air distribution system.

#### 1.3.1 Air for combustion and ventilation

Please refer to the CAN/CSA-B139 Installation Code for complete regulations and for guidance on retrofit applications.

This furnace should be installed in a location in which the facilities for ventilation permit satisfactory combustion of oil, proper venting and the maintenance of ambient temperatures at safe limits under normal conditions of use. The location should not interfere with the proper circulation of air within the confined space.

When this furnace is installed in a closet or similar enclosure, 2 ventilation openings are required for combustion air. The openings should be located about 15.2 cm (6") from the top and the bottom of the enclosure at the front of the furnace. Table 1 indicates the minimum dimensions required for these ventilation openings.

**TABLE 1**

Input (BTU/h)	Width	Height
75,000 – 105,000	45.72 cm (18")	20.32 cm (8")
120,000 – 155,000	50.80 cm (20")	25.40 cm (10")



## WARNING

**Do not block the combustion air openings in the furnace. Any blockage will result in improper combustion and may result in a fire hazard and/or cause bodily harm.**

For chimney application, the barometric draft regulator included with the furnace, shall be installed in the same room or enclosure as the furnace, in such a manner as to prevent any difference in pressure between the regulator and the combustion air supply.

Air requirements for the operation of exhaust fans, kitchen ventilation systems, clothes dryers, and fireplaces shall be considered in determining the adequacy of the space to provide combustion air requirements.

In unconfined spaces, in buildings of conventional frame, brick or stone construction, infiltration may be adequate to provide air for combustion, ventilation and dilution of flue gases. This determination must be made on an individual installation basis and must take into consideration the overall volume of the unconfined space, the number of windows and ventilation openings, the number of doors to the outside, internal doors which can close off the unconfined space and the overall air tightness of the building construction.

Many new buildings and homes (and older ones that have been weatherized must be considered as being tight construction and, therefore, infiltration will not be sufficient to supply the necessary air for combustion and ventilation.

A building can be considered as being of tight construction when:

- Walls and ceilings exposed to the outside have a continuous water vapour retarder with a rating of one perm or less, openings have gaskets or are sealed and/or;
- Weather-stripping has been added on operable windows and doors, and/or;
- Caulking or sealant has been applied to areas such as joints around window and doorframes, between sole plates and floors, between wall-ceiling joints, between wall panels, at penetrations for plumbing, electrical and fuel lines and at other openings.

### 1.3.2 Duct recommendations



## WARNING

**When ducting supplies air to a space other than where the furnace is located, the return air must be sealed and also be directed to the space other than where the furnace is located. Incorrect ductwork termination and sealing will create a hazardous condition that can lead to bodily harm.**

## CAUTION

Return air grilles and warm air registers must not be obstructed.

**IMPORTANT:** The dampers should be adequate to prevent cooled air from entering the furnace, and if manually operated, must be equipped with the means to prevent operation of either the cooling unit or the furnace, unless the damper is in the full cool or heat position.

**NOTE:** THE BACK SHOULD **NOT** BE CUT OUT FOR RETURN AIR DUCTING

The proper sizing of warm air ducts is necessary to ensure satisfactory furnace operation. Ductwork should be in accordance with the latest editions of NFPA-90A (Installation of Air Conditioning and Ventilating Systems) and NFPA-90B (Warm Air Heating and Air Conditioning Systems) or Canadian equivalent.

The supply ductwork should be attached to the flanged opening provided at the discharge end of the furnace. See Figures 7.1 & 7.2, p.15 and 16, for the dimensions of this opening.

Knockouts are provided on both sides of the furnace to cut the required size of opening for the installation of the return air ductwork. This can be done on either the right or the left side of the furnace. See Table 2, p. 9, for location and dimensions.

Also, there is provision on this furnace for a bottom return air duct. Knockouts are provided in the floor of the furnace to facilitate the cut-out requirement for the air filter rack and return ductwork. (We recommend the use of this opening for horizontal and counterflow installations).

The following recommendations should be followed when installing ductwork:

- Install locking type dampers in all branches of the individual ducts to facilitate balancing the system. Dampers should be adjusted such a way as to ensure the proper static pressure at the outlet of the furnace;
- A flexible duct connector of non-combustible material should be installed at the unit on both the supply and return air side. In applications where an extremely quiet operation is necessary, the first 3 m (10') of supply and return ducts should be internally lined with acoustical material (if possible);
- In cases where the return air grille is located close to the fan inlet, there should be at least one 90° turn between fan inlet and grille. Further reduction in sound level can be accomplished by installing acoustical turning vanes or lining the duct as described in item b. above;
- When a single air grille is used, the duct between grille and furnace must be the same size as the return air opening in the furnace.

When installing the furnace with cooling equipment for year round operation, the following recommendations must be followed for tandem or parallel air flow:

- On tandem airflow applications, the coil is mounted after the furnace in an enclosure in the supply air stream. The furnace blower is used for both heating and cooling airflow;

- b. On parallel airflow installation, dampers must be provided to direct air over the furnace heat exchanger when heat is desired and over the cooling coil when cooling is desired.



## WARNING

**The coil MUST be installed on the air discharge side of the furnace. Under no circumstances should the airflow be such that cooled, conditioned air is allowed to pass over the furnace heat exchanger. This will cause condensation in the heat exchanger and possible failure of same, which could result in a fire hazard and/or other hazardous conditions that may lead to bodily harm. Heat exchanger failure due to improper installation may not be covered by the warranty.**

### 1.3.3 Venting instructions

Venting of the furnace must be to the outside and in accordance with local codes and/or requirements of local authorities.

OIL FIRED APPLIANCES INSTALLED WITH CHIMNEY SHALL BE CONNECTED TO FLUES HAVING SUFFICIENT DRAFT AT ALL TIMES TO ENSURE SAFE AND PROPER OPERATION OF THE APPLIANCE.

For additional venting information please refer to ANSI/NFPA 211 Chimneys, Fireplaces, Vents and Solid Fuel Burning Appliances and/or the CSA B139 Installation Code.

This furnace is certified for use with a Type "L" vent (maximum flue gas temperature 302°C (575°F)). The flue pipe clearance knockout in the front top or side panel should be removed. Install the flue elbow so that it exits the furnace cabinet through that opening.

### Pre-installation vent system inspection

Before this furnace is installed, it is strongly recommended that any existing vent system be completely inspected.

On any chimney or vent, this should include the following:

- Inspection for any deterioration in the chimney or vent. If deterioration is discovered, the chimney must be repaired or the vent replaced;
- Inspection to ascertain that the vent system is clear and free of obstructions. Any blockages must be removed before installing this furnace;
- Cleaning the chimney or vent if previously used for venting a solid fuel burning appliance or fireplace;
- Confirming that all unused chimney or vent connections are properly sealed;
- Verification that the chimney is properly lined and sized per the applicable codes. (Please refer to list of codes on page 3)

### Masonry Chimneys

This furnace may be vented into an existing masonry chimney. However, it must not be vented into a chimney servicing a solid fuel-burning appliance. Before venting this furnace into a chimney, the chimney must be checked for deterioration and repaired if necessary. The chimney must be properly lined and sized per local and/or national codes.

If the furnace is vented into a common chimney, the chimney must be of sufficient area to accommodate the total flue products of all appliances vented into the chimney.

The following requirements are provided for a safe venting system:

- Ensure that the chimney flue is clear of any dirt or debris;
- Ensure that the chimney is not servicing an open fireplace;
- Never reduce the pipe size below the outlet size of the furnace;
- All pipes should be supported, using the proper clamps and/or straps. These supports should be installed at least every 4 feet;
- All horizontal runs of pipe should have at least 6.4 mm (1/4") of upward slope per 0.3 m (1');
- All runs of pipe should be as short as possible with as few turns as possible;
- Seams should be tightly joined and checked for leaks;
- The flue pipe must not extend into the chimney but be flush with the inside wall;
- The chimney must extend 0.9 m (3') above the highest point where it passes through a roof of a building and at least 0.6 m (2') higher than any portion of a building within a horizontal distance of 3 m (10'). It shall also be extended at least 1.5 m (5') above the highest connected equipment flue collar;
- Check local codes for any variances.

### Factory Built Chimneys

Approved factory built chimneys may be used. Refer to chimney manufacturer's instructions for proper installation.

### 1.3.4 Draft Regulator (Chimney venting)

The draft regulator supplied with the furnace must be used for proper functioning. Installation instructions are included with the control.

### 1.3.5 Blocked vent shut-off (BVSO) For chimney venting



## WARNING

**It is imperative that this device be installed by a qualified agency.**

This device is designed to detect the insufficient evacuation of combustion gases in the event of a vent blockage. In such a case the thermal switch will shut down the oil burner. The device will then need to be re-armed MANUALLY.

Please refer to Figures 1 to 6, p. 7 & 8, the wiring diagrams on pages 17 and 18 and the detailed instructions supplied with the BVSO for the installation and wiring procedures. The length of wires supplied with the unit is such that the safety device must be installed between the flue outlet of the appliance and the draft regulator, as indicated in the instructions.

It is also essential that the BVSO be maintained annually. For more details please refer to the instructions supplied with the device itself, as well as Section 3 of this Manual.

## CAUTION

A positive pressure venting system (Sealed Combustion System or Direct Vent) MUST NOT use the BVSO. Follow the instructions supplied with the venting system.

FIGURE 1

**Blocked Vent Shut-Off device wiring**  
Installation shown: Upflow with vertical exhaust

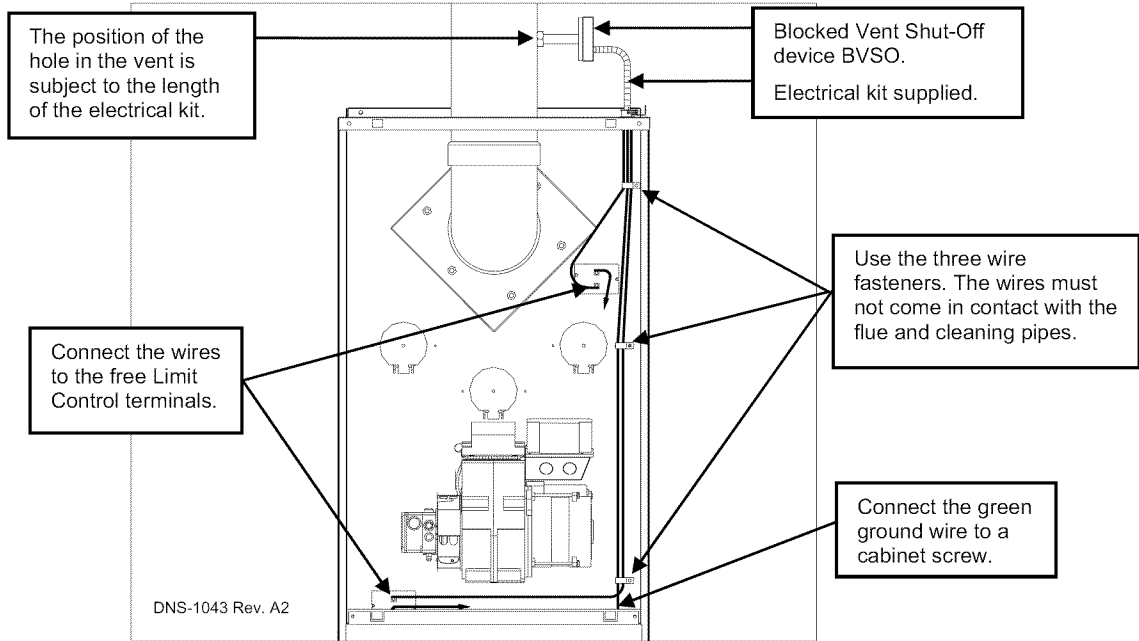

FIGURE 2

**Blocked Vent Shut-Off device wiring**  
Installation: Upflow with vertical exhaust

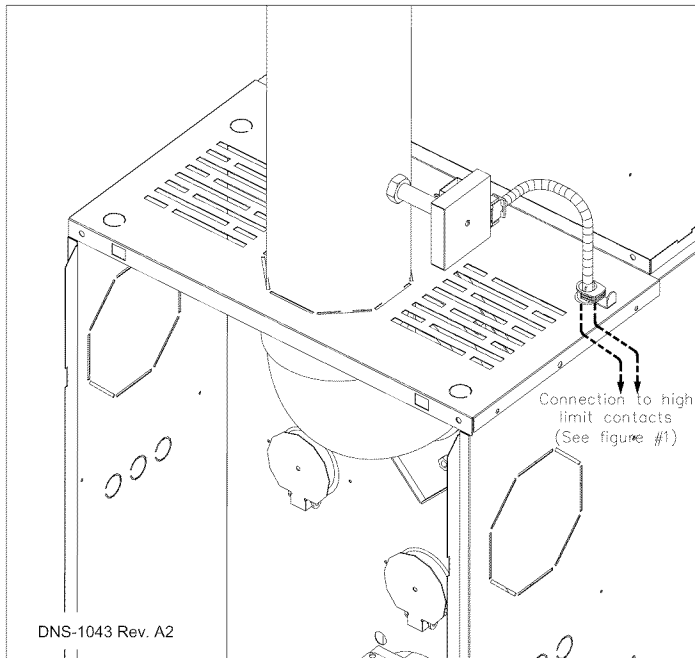
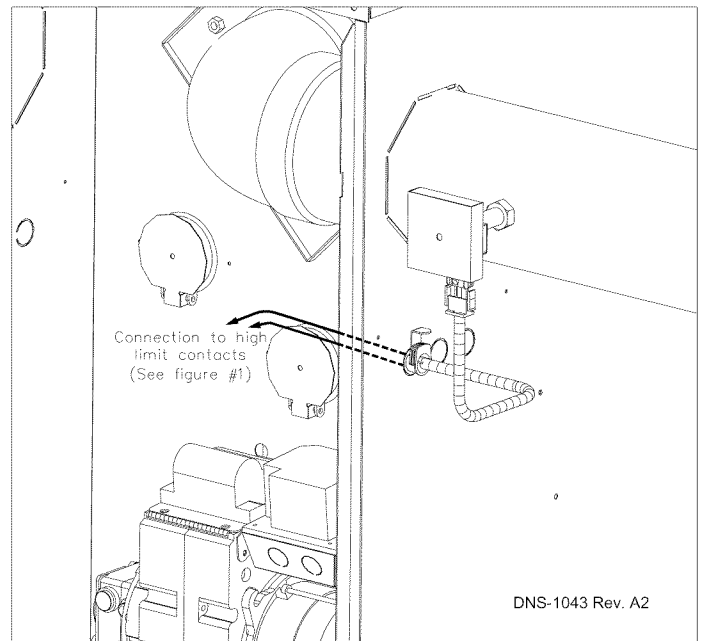

FIGURE 3

**Blocked Vent Shut-Off device wiring**  
Installation: Upflow with horizontal exhaust



**FIGURE 4**

**Blocked Vent Shut-Off device wiring**  
**Installation: Horizontal with horizontal exhaust**

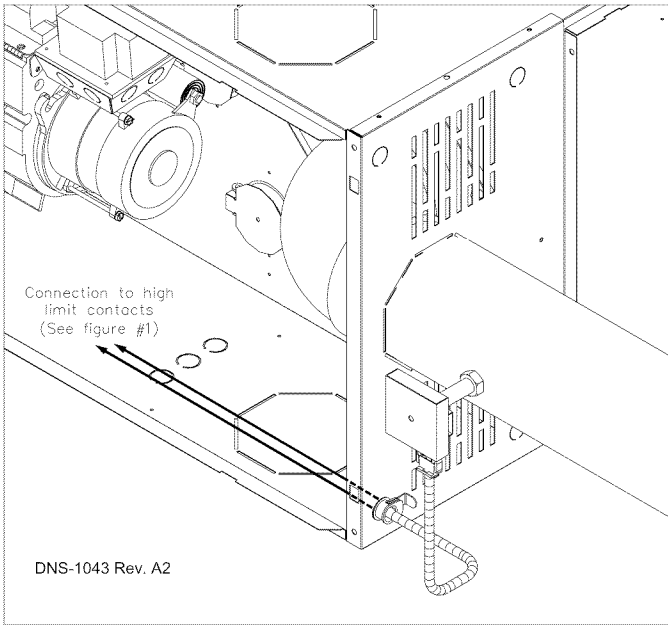

**FIGURE 5**

**Blocked Vent Shut-Off device wiring**  
**Installation: Horizontal with vertical exhaust**

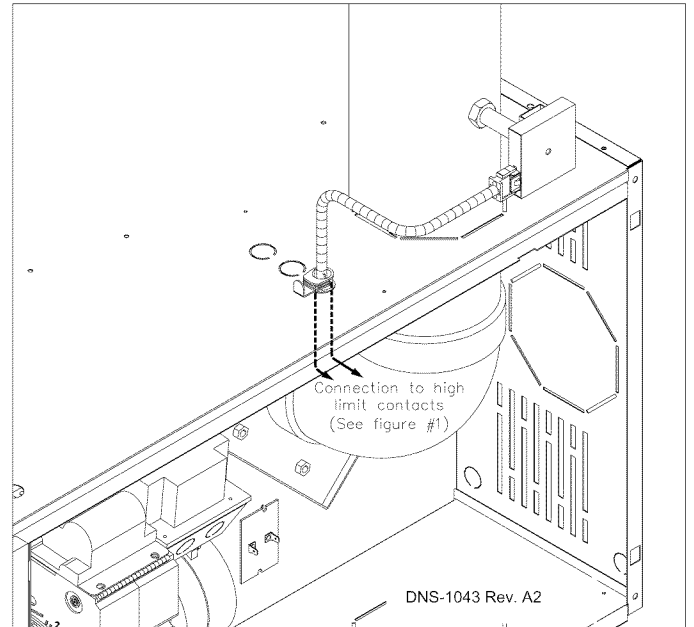

**FIGURE 6**

**Blocked Vent Shut-Off device wiring**  
**Installation: Downflow**

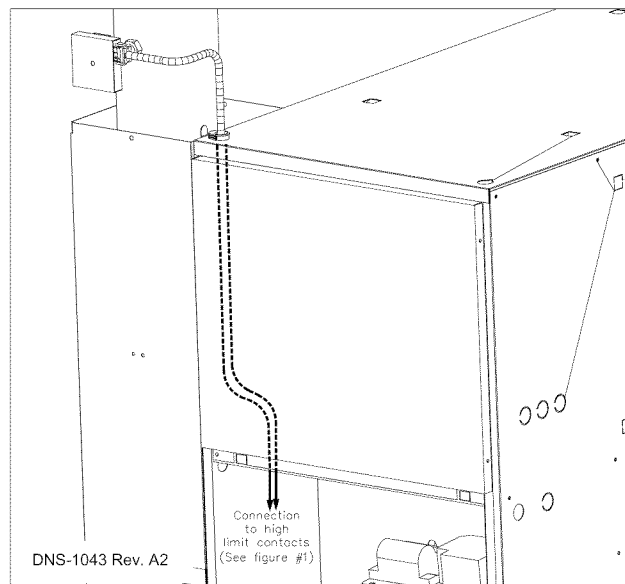

### 1.3.6 Venting instructions (Sealed Combustion Systems)

Please refer to the Sealed Combustion System or Direct Vent System instruction manuals.

### 1.3.7 Oil burner

This furnace is equipped with a high pressure atomizing retention head type burner for use with not heavier than grade 2 Fuel Oil. The mounting flange is fixed to the burner air tube and no adjustment is required for insertion length.

#### CAUTION

**NEVER** use the “interrupted ignition” function if a Beckett AFG burner is installed on the furnace.

#### Oil Connections

Complete instructions for installation of the fuel oil piping will be found in the oil burner installation instructions included with the furnace.

Oil line entry holes are located in the side panels. Two holes are provided on each side, so that a two-pipe system can be used if desired.

A 10-micron (or finer) oil filter should be used with all oil burners, installed as closely as possible to the burner.

### 1.3.8 Electrical system

The appliance must be installed in accordance with the current ANSI/NFPA 70 National Electrical Code, CSA C22.1 Canadian Electrical Code Part 1 and/or local codes.

The control system depends on the correct polarity of the power supply. Connect “HOT” wire (H) and “NEUTRAL” wire (N) as shown in Figures 8.1 to 8.2, p. 17 and 18.

A separate line voltage supply should be used with fused disconnect switch or circuit breaker between the main power panel and the unit.



#### WARNING

**The unit cabinet must have an uninterrupted or unbroken electrical ground to minimize personal injury if an electrical fault should occur. A green ground screw is provided in the control box for this connection.**

Use only copper wire for 115V supply service to the unit.

Metallic conduit (where required/used) may terminate at the side panel of the unit. It is not necessary to extend the conduit inside the unit from the side panel to the control box.

When replacing any original furnace wiring, use only 105°C, 16 AWG copper wire.

Instructions for wiring the thermostat are provided with the thermostat (field supplied). Wire the connections to the 24-volt terminal board on the primary relay as shown in Figures 8.1 to 8.2, p. 17 & 18.

When installing optional accessories to this appliance, follow the manufacturer’s installation instructions included with the accessory. Other than wiring for the thermostat, wire with a minimum of type “T” insulation (17°C rise (63°F)) must be used for accessories.

### 1.3.9 Air filter

An external filter rack is provided as standard equipment with this furnace. The filter rack can be installed on the right or left side panel, or on the bottom of the furnace to accommodate the return air ductwork. A sufficient clearance should be provided for air filter access. Please refer to Table 2 for filter rack flange dimensions for return air duct.

TABLE 2

Furnace Model	Air Filter Size	Flange Opening
AMP & NOMF (105 & 106)	40.64 x 60.96 cm	38.10 X 58.42 cm
	16" x 24"	15" x 23"
AMP & NOMF (120, 155 & 156)	45.72 X 76.20 cm	43.18 X 73.66 cm
	18" x 30"	17" x 29"

### 1.3.10 Air Conditioner (or Heat Pump)

An air conditioning coil may be installed on the supply air side ONLY.



#### WARNING

**Poisonous carbon monoxide gas hazard.**

**Install the evaporator coil on the supply side of the furnace ducting ONLY.**

**An evaporator coil installed on the return air side of the ducting can cause condensation to form inside the heat exchanger, resulting in heat exchanger failure. This in turn can result in death, bodily injury**

No minimum clearance is required between the bottom of the coil drain pan and the top of the heat exchanger. If a heat pump is installed, a “dual-energy” thermostat, or other control is required, in order to prevent the simultaneous operation of the furnace and the heat pump. It also prevents a direct transition from heating by way of the heat pump to heating with oil. Refer to the thermostat instructions or those of another control used for the proper wiring.

If a coil blower compartment is used, install air tight, motorized and automatic air dampers. Cold air coming from the coil and passing across the furnace can cause condensation and shorten the life of the heat exchanger.

### 1.3.11 Horizontal or downflow installation

1. On horizontal installations, determine which “side” will become the “top”, when the unit is laid down. Remove the flue pipe clearance knockout from the top front of that side panel. Install the flue elbow so that it exits the cabinet of the furnace through that opening;



2. On counterflow Installations, the flue pipe must exit the cabinet through one of the side panel openings (as above), then extended up the side of the furnace. Ensure that adequate clearances to combustibles are observed. It may be necessary to install a sheet-metal shield on an adjacent wall to prevent any possibility of a fire hazard;
3. Remove the burner by loosening the mounting nuts and turn the oil burner slightly counter clockwise to unlock the burner flange. Avoid putting undue strain on burner wiring. It may be necessary to disconnect the burner wiring in some cases;
4. To reinstall the burner, insert the burner and the burner flange screws and turn the burner clockwise to lock it; then tighten the nuts.

**IMPORTANT:** The burner must always be installed in the upright position with the ignition control on top.



**DANGER**

**Do not use this furnace as a construction heater. Use of this furnace as a construction heater exposes it to abnormal conditions, contaminated combustion air and the lack of air filters. Failure to follow this warning can lead to premature furnace failure and/or vent failure, which could result in a fire hazard and/or bodily harm.**

## PART 2 START-UP

### 2.1 OPERATIONAL CHECKLIST

- 1=>Has the blower wheel support been removed?
- 2=>Has the electrical wiring been completed according to Figures 8.1 and 8.2, p. 17 and 18?
- 3=>Has the access blower door been secured in place?
- 4=>Is the valve on the oil line open?
- 5=>Has the "RESET BUTTON" on the Primary Control been pushed?
- 6=>Are the flame observation door and the two clean-out access doors located at the front of the unit closed?
- 7=>Is the room thermostat in the heating mode and set above room temperature?
- 8=>Set the main electrical switch to the "ON" position and the burner should start.

**CAUTION**

Do not tamper with the unit or its controls. Call a qualified service technician.

### 2.2 COMBUSTION CHECK

In order to obtain optimum performance from the oil burner, the following set-up procedures must be followed by referring to the Technical Specifications, Table 3, p. 14 in this manual:

1. A test kit to measure the smoke, flue draft and over-fire pressure should be used in order to obtain the proper air band setting. Although all of the above measurements are required for optimum set up and efficiency, the most important reading that must be taken is the smoke number in the flue pipe, downstream from the regulator;

2. The proper smoke number, as established by way of engineering tests, is between 0 and 1. This degree of smoke emission is commonly referred to as a "trace". It is recommended that a Bacharach True Spot Smoke Test kit or equivalent be used;
3. On chimney installations only, a barometric draft regulator (supplied with the furnace) must be installed as closely to the breech of the furnace as possible, in order to ensure proper draft through the furnace. The barometric damper must be mounted with the hinge pins in a horizontal position and the face of the damper vertical for proper functioning, (see instructions included with damper). After the furnace has been firing for at least five minutes, the draft regulator should be set to between -0.025" W.C. and -0.035" W.C.;
4. The overfire pressure that is taken through the observation door located in the centre of the front panel above the burner is a measurement that is necessary to determine if there is a blockage in the heat exchanger or the flue pipe. Please refer to the Technical Specifications in this manual for overfire pressure values. A high pressure condition may be caused by excessive combustion air due to the air band being too wide open or a lack of flue draft (chimney effect) or some other blockage, such as soot in the secondary section of the heat exchanger or the use of an oversize nozzle input or high pressure pump;
5. CO<sub>2</sub> and flue temperature instruments will enable you to obtain the data that are required to determine the true efficiency of the furnace. Although this information is nice to have, it is not essential in the basic set up of the furnace. The proper procedure for performing this operation is as follows:
  - a. Start the appliance and proceed with the smoke test at the test port provided on the BREECH PLATE (of the Sealed Combustion System) or on the flue pipe just before the draft regulator (chimney application), and adjust the burner to a setting of between a "trace" and #1 smoke after 5 to 10 minutes of operation;
  - b. Take a CO<sub>2</sub> reading and mark it down;

- c. Open the burner air shutter to get 1.5% CO<sub>2</sub> less than the previous reading noted in b. above and take a smoke test on this condition;
  - d. The new smoke reading should give you a ZERO smoke reading.
6. A 10-micron (or less) oil filter should be installed as closely to the burner as possible with all oil burners, but it is essential for burners with a low firing rate. We recommend the use of a low pressure drop oil filter with a capacity greater than that of the fuel pump;
  7. On a new installation, the air trapped in the oil line leading from the tank to the nozzle must be thoroughly purged in order to prevent excessive after drip. The oil pump is equipped with a special fitting that facilitates the purging of any air between it and the tank. The proper procedure for performing this operation is as follows:
    - a. Place a piece of 1/4" diameter clear plastic tubing over the purge fitting on the oil pump;
    - b. Start the oil burner, then open the purge fitting and allow the burner to run until the purge tube is completely free of air bubbles;
    - c. At this point tighten the purge fitting, which will allow the oil to run to the nozzle and fire the burner. If the purging takes longer than 15 seconds and no flame has been established the burner will stop. Push the reset button on top of the Primary Control to restart the burner.
- For detailed information on the operation of the Primary Control please refer to the instructions included with the furnace or the burner.
8. After all the set up procedures mentioned above have been completed, the burner should be fired and an inspection mirror should be used to observe the flame pattern at the tip of the nozzle. Any irregularities such as burning to one side or pulsating flame patterns should be corrected by changing the nozzle.

## 2.3 SUPPLY AIR ADJUSTMENTS (4-SPEED MOTORS)

On units equipped with 4-speed blower motors, the supply air must be adjusted based on heating/air conditioning output and the static pressure of the duct system. For the desired air flow please refer to the following table as well as the air flow Table 3, p. 14, based on static pressure in the Technical Specifications section of this manual.

### Blower Speed Adjustments (4 Speed Motors, Heating Mode)

FURNACE MODEL	HEATING INPUT	RECOMMENDED BLOWER SPEED
AMP105 NOMF105/106	0.50 USGPH	MED-LOW
	0.65 USGPH	MED-HIGH
	0.75 USGPH	HIGH
AMP120 NOMF155/156	0.85 USGPH	MED-LOW
	1.00 USGPH	MED-HIGH
	1.10 USGPH	HIGH

### Blower Speed Adjustments (4 Speed Motors, Cooling Mode)

FURNACE MODEL	COOLING CAPACITY	RECOMMENDED BLOWER SPEED
AMP105 NOMF105/106	2.0 TONS	MED-LOW
	2.5 TONS	MED-HIGH
	3.0 TONS	HIGH
AMP120 NOMF155/156	3.5 TONS	MED-LOW
	4.0 TONS	MED-HIGH
	5.0 TONS	HIGH

To effect the adjustment, the RED and BLUE wires can be changed on the motor. Also, please refer to the position of the wires on the electronic board of the unit and consult the wiring diagrams. If the heating and the air conditioning speeds are the same, the RED wire must be moved to "UNUSED LEADS" on the electronic board and the jumper provided with the BLUE wire must be used between the "HEAT" and "COOL" terminals.

The blower start/stop delays can be adjusted by positioning the DIP switches on the electronic board as shown on the following figures.

#### Blower "OFF" delay Board # ST9103A

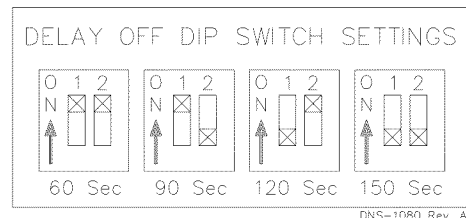

#### Blower start / stop delays Board # 1158

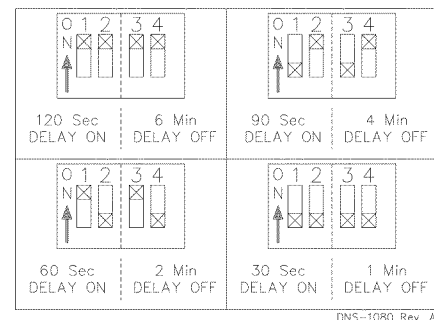

## 2.4 LIMIT CONTROL CHECK

After the furnace has been in operation for at least 15 minutes, restrict the return air supply by blocking the filters or closing the return registers and allow the furnace to shut down on High Limit. The burner will shut OFF but the main blower should continue to run.

Remove the restriction and the burner should come back on in a few minutes.

## 2.5 YEAR ROUND AIR CONDITIONING

The furnace is designed for use in conjunction with cooling equipment, to provide year round air conditioning. The blower has been sized for both heating and cooling; however, the fan motor speed may need to be changed to obtain the necessary cooling airflow.

## 2.6 HEATING

The blower speed is factory set to deliver the required airflow at normal duct static pressure.

## 2.7 COOLING

The blower speed may be adjusted in the field to deliver the required airflow for cooling applications, as outlined in Table 3, p. 14.

## 2.8 CONSTANT BLOWER SWITCH

This furnace is equipped with a constant low speed blower option. Whenever the room thermostat is not calling for heating or cooling, the blower will run on low speed in order to provide air circulation. If this constant blower option is not desired, the rocker switch on the side of the control box can be used to turn it off.

# PART 3 MAINTENANCE

This furnace should never be operated without an air filter. Disposable filters should be replaced at least once a year. If the furnace is equipped to provide cooling as well, filters should be replaced a minimum of twice a year.

### WARNING

Before performing any service functions, make sure that all utilities are turned "OFF" upstream from the appliance, unless operations specifically require the power to be on. Failure to comply with this warning will cause a fire hazard and/or bodily harm.

For optimal performance, the oil burner nozzle should be replaced at least once a year. Contact a qualified service technician for the installation.

The procedure for nozzle installation and/or replacement is outlined in the oil burner Instruction Manual that was supplied with the furnace.

After replacement of the nozzle, the burner should be adjusted in accordance with the "COMBUSTION CHECK" outlined in Section 2.2 of this manual.

## 3.1 HEAT EXCHANGER CLEANING

Ordinarily, it is not necessary to clean the heat exchanger or flue pipe every year, but it is advisable to have a qualified service technician check the unit before each heating season to determine whether cleaning or replacement of parts is necessary.

If cleaning is necessary, the following steps should be taken:

1. Turn "OFF" all utilities upstream from the furnace;
2. Disconnect the flue pipe (only with chimney venting and rigid flue pipe);
3. Remove the breech plate;
4. Remove the radiator baffle;
5. Disconnect the oil line and remove the oil burner from the furnace;

6. Open the two cleanout doors located in the upper part of the front panel of the furnace;
7. Clean the secondary tubes and the primary cylinder with a stiff brush and a vacuum cleaner;
8. Before reassembly, the heat exchanger and combustion chamber should be inspected to determine if replacement is required;
9. After cleaning, replace the radiator baffle, flue collar plate, oil burner and close the two clean out access doors. Reconnect the flue pipe and oil line;
10. Readjust burner for proper operation.

## 3.2 BLOWER REMOVAL

To remove the blower from the furnace:

1. Turn "OFF" all utilities upstream from the furnace;
2. Remove the burner access door and blower door;
3. Remove the blower retaining screw (on the blower partition panel);
4. Remove the control box cover and disconnect the thermostat and power wires from the board;
5. Slide the blower on the rails toward the front of the unit;
6. Reverse the above steps to reinstall the blower. Please refer to the wiring diagrams, Figures 8.1 to 8.2, p. 17 & 18 in this manual, or the diagram located on the inside of the blower door to properly rewire the unit.

### CAUTION

Be sure that the blower is adequately supported when sliding it off the mounting rails, especially in the horizontal or counter flow positions, in order to prevent dropping it and injuring yourself or damaging the blower!

## 3.3 BLOCKED VENT SHUT OFF (BVSO) CLEANING

For continuous safe operation, the Blocked Vent Shut-off Device (BVSO) must be inspected and maintained annually by a qualified service technician.

1. **Disconnect power to the appliance;**
2. Remove the two screws holding on the BVSO assembly cover;
3. Remove the cover;

4. Remove the two screws holding the control box to the heat transfer tube assembly. Sliding the control box in the appropriate direction will unlock it from the heat transfer tube assembly;
5. Carefully remove any build-up from the thermal switch surface;

6. Clean and remove any build-up or obstruction inside the heat transfer tube;
7. Re-mount, lock and fasten the control box with the 2 screws removed in step 4;
8. Re-attach the assembly cover with the screws removed in step 2;
9. Re-establish power to the unit.

**CAUTION**

Do not dent or scratch the surface of the thermal switch. If the thermal switch is damaged it **MUST** be replaced.

## PART 4 FURNACE INFORMATION

Model: \_\_\_\_\_ Serial number: \_\_\_\_\_

Furnace installation date: \_\_\_\_\_

Service telephone – Day: \_\_\_\_\_ Night: \_\_\_\_\_

Dealer name and address: \_\_\_\_\_

### START-UP TEST RESULTS

Nozzle: \_\_\_\_\_ Pressure: \_\_\_\_\_ lb/psi

Burner adjustments: Primary air \_\_\_\_\_

Fine air \_\_\_\_\_

Drawer Assembly \_\_\_\_\_

CO<sub>2</sub>: \_\_\_\_\_ % Smoke scale: \_\_\_\_\_ (Bacharach)

Gross stack temperature: \_\_\_\_\_ °F

Ambient temperature: \_\_\_\_\_ °F

Chimney draft: \_\_\_\_\_ "W.C.

Overfire draft: \_\_\_\_\_ "W.C.

Tests performed by: \_\_\_\_\_

**TABLE 3**  
**Technical Specifications**

Model: AMP & NOMF	105 / 106			120 / 155 / 156		
<b>RATING AND PERFORMANCE</b>						
Firing rate (USGPH)*	0.5	0.65	0.75	0.85	1.00	1.10
Input (BTU/h)*	70,000	91,000	105,000	119,000	140,000	154,000
Heating capacity (BTU/h)*	57,000	74,000	85,000	97,000	115,000	126,000
Heating temperature rise*	13 - 29°C (55 - 85°F)			13 - 29°C (55 - 85°F)		
Flue draft with chimney (inch of w.c.)	-0.06" to -0.025"			-0.06" to -0.025"		
Overfire pressure with chimney (inch of w.c.)	max +0.025"			max +0.025"		
Flue pressure with direct vent (inch of w.c.)				+0.10" to +0.25"		
Overfire pressure with direct vent (inch of w.c.)				+0.12" to +0.27"		
<b>BECKETT BURNER; MODEL AFG (3450 rpm)</b>	<b>AFG53, F3 head</b>			<b>AFG53, F3 head</b>	<b>AFG53, F6 head</b>	
Burner tube insertion length	2 7/8 "			2 7/8 "	2 7/8 "	
Low firing rate baffle	YES			YES	YES	
Static disc, model	3 3/8" # 31646			2 3/4" # 3383	2 3/4" # 3383	
Nozzle (Delavan)	0.50 - 70W	0.55 - 70B	0.65 - 70B	0.75 - 70B	0.85 - 70B	0.85 - 70B
Pump pressure (PSIG)*	100	140	130	130	140	170
Combustion air adjustment (band/shutter)	0 / 5	0 / 7	0 / 8	1 / 8	4 / 4	2 / 8
AFUE % (From CSA B212 standard and Canadian regulation)	80.68	80.4	80.75	82.25	81.01	81.36
AFUE % max. (From ASHRAE 103 standard and US regulation)	80.5	80.5	80.5	80.5	80.5	80.5
<b>RIELLO BURNER; 40-F (chimney vent)</b>	<b>F3 head with VSBT</b>			<b>F5 head with VSBT</b>		
Burner tube insertion length	3 9/16 "			3 9/16 "		
Nozzle (Delavan)	0.40 - 70A	0.50 - 70W	0.65 - 70W	0.75 - 70B	0.85 - 70W	1.00 - 70W
Pump pressure (PSIG)*	155	170	135	130	140	120
Combustion air adjustment (turbulator/damper)	0 / 3	0 / 3.5	0 / 4	0 / 3	0 / 3.5	0 / 4
AFUE % (From CSA B212 standard and Canadian regulation)	82.9	82.4	81.8	▲85.1	83.8	83.0
AFUE % max. (From ASHRAE 103 standard and US regulation)	82.5	82.0	82.0	83.0	82.5	82.5
<b>RIELLO BURNER; 40-BF (direct vent)</b>				<b>F5 head with VSBT</b>		
Burner tube insertion length				3 9/16 "		
Nozzle (Delavan)				0.75 - 70B	0.85 - 70W	1.00 - 70W
Pump pressure (PSIG)*				130	140	120
Combustion air adjustment (turbulator/damper)				0 / 3.75	1/4	1.5/5
AFUE % (From CSA B212 standard and Canadian regulation)				▲85.1	83.8	83.0
AFUE % max. (From ASHRAE 103 standard and US regulation)				83.0	82.5	82.5
<b>ELECTRICAL SYSTEM</b>						
Volts - Hertz - Phase	115 - 60 - 1			115 - 60 - 1		
Rated current (Amps)	12.2			15.7		
Minimum ampacity for wire sizing	13.7			18.1		
Max. wire length (ft.)	26			26		
Max. fuse size (Amps)	15			20		
Control transformer	40 VA			40 VA		
External control power available	Heating	40 VA			40 VA	
	Cooling	30 VA			30 VA	
<b>BLOWER DATA</b>						
Blower speed at 0.50" W.C. static pressure	MED-LOW	MED-HIGH	HIGH	MED-LOW	MED-HIGH	HIGH
Motor (HP) / number of speeds	1/3 HP / 4 speeds			3/4 HP / 4 speeds		
Blower wheel size (in.)	10" x 10"			12" x 10"		
<b>GENERAL INFORMATION</b>						
Overall dimensions (width x depth x height)	20" x 35" x 48½"			20" x 39½" x 53"		
Supply air opening (width x depth)	18.625" x 20"			19" x 24"		
Return air opening (depth x height, with factory filter rack)	15" x 23"			17" x 29"		
Filter size	16" x 24"			18" x 30"		
Shipping weight	100 kg / 221 lbs			122 kg / 270 lbs		
Air conditioning, maximum output (tons) at 0.5 SP	3 tons			5 tons		

\* INPUT & OUTPUT ADJUSTMENT (see information below)  
 Pump pressure can be increased up to 180 PSIG (200 PSIG with Beckett burner at 1.10 USGPH)  
 Adjust flue gas temperature between 400°F and 575°F.  
 Adjust fan speed for air temperature rise of 55°F to 85°F.



**TABLE 4**  
**Air delivery in CFM with air filter**

SPEED	AMP, LBM & NOMF (075, 090 and 105) - EXTERNAL STATIC PRESSURE WITH AIR FILTER			
	0.2" (W.C.)	0.3" (W.C.)	0.4" (W.C.)	0.5" (W.C.)
HIGH	1,425	1,350	1,305	1,250
MED-HIGH	1,130	1,045	1,000	950
MED-LOW	840	810	770	740
SPEED	AMP, LBM & NOMF (120, 140 et 155) - EXTERNAL STATIC PRESSURE WITH AIR FILTER			
	0.2" (W.C.)	0.3" (W.C.)	0.4" (W.C.)	0.5" (W.C.)
HIGH	2,080	2,041	1,965	1,864
MED-HIGH	1,892	1,859	1,770	1,675
MED-LOW	1,556	1,475	1,394	1,318

**FIGURE 7.1**  
**Models : AMP & NOMF 105 / 106**

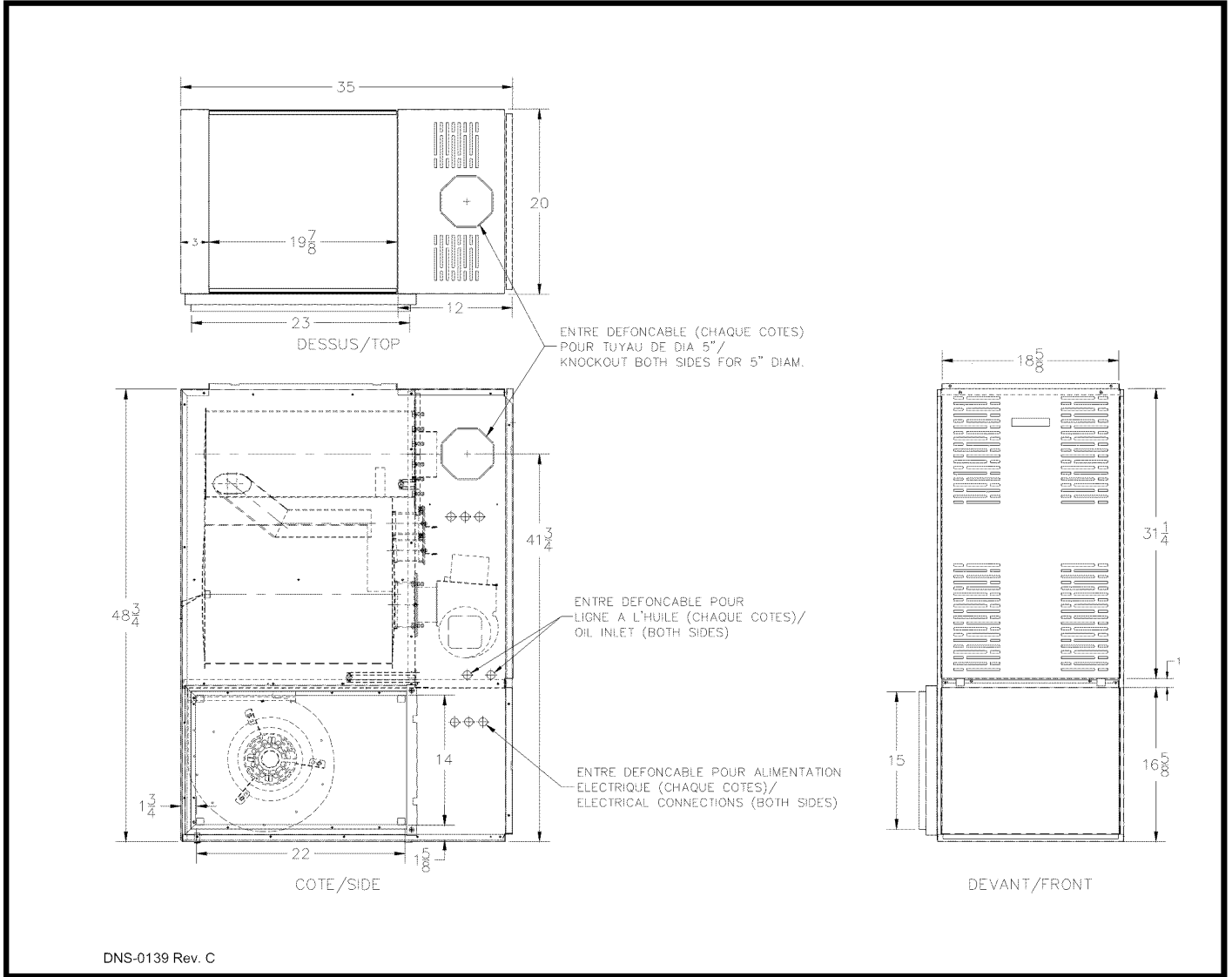
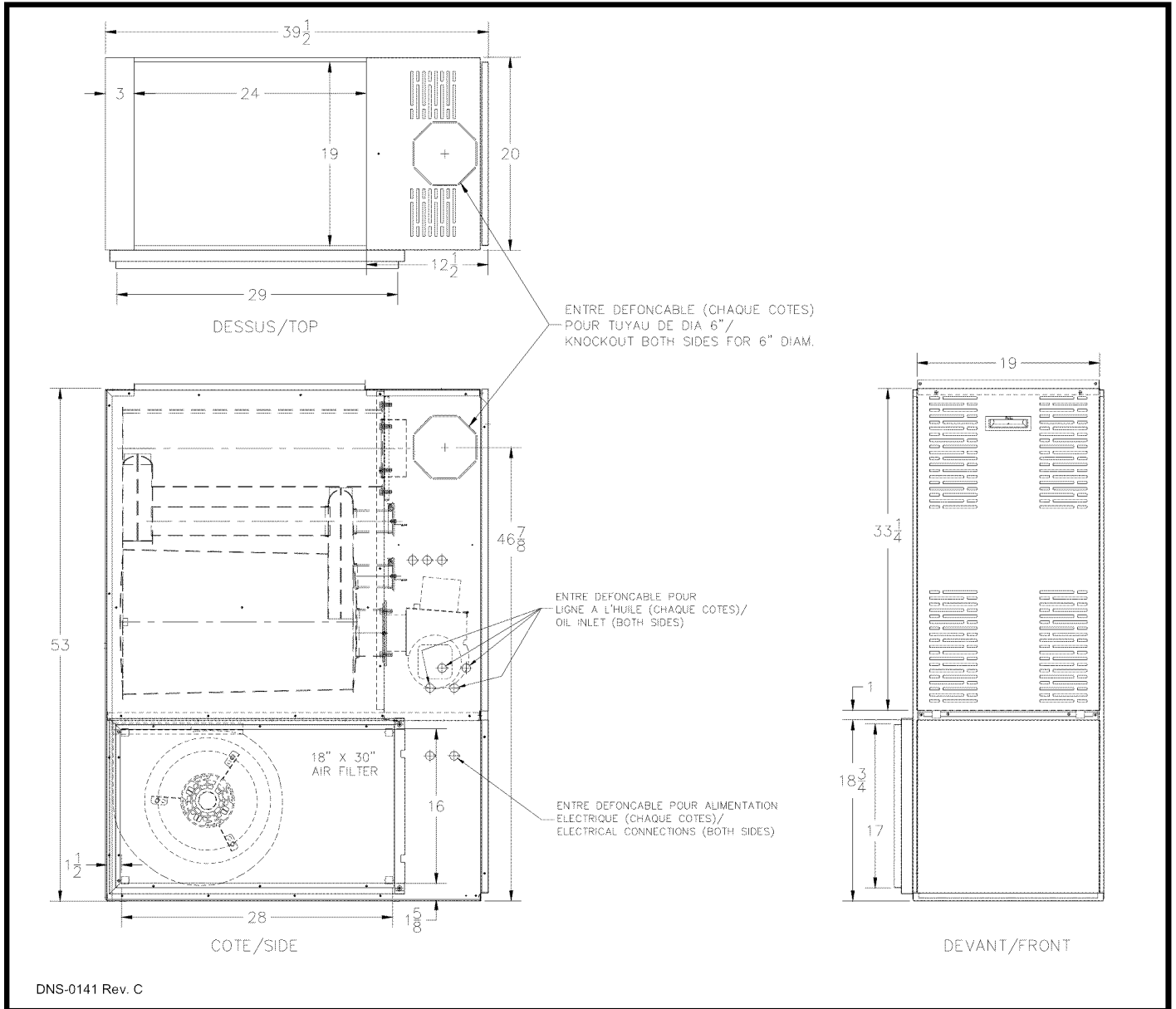

**TABLE 5.1**  
**Minimum clearances to combustible materials**

LOCATION	APPLICATION	UPFLOW	DOWNFLOW	HORIZONTAL
SIDES	FURNACE	Ø	5.08 cm (2")	5.08 cm (2")
	SUPPLY PLENUM WITHIN 6 ft. OF FURNACE	2.54 cm (1")	5.08 cm (2")	2.54 cm (1")
BACK	FURNACE	Ø	2.54 cm (1")	Ø
TOP	FURNACE OR PLENUM	5.08 cm (2")	5.08 cm (2")	5.08 cm (2")
	HORIZONTAL WARM AIR DUCT WITHIN 6 ft. OF FURNACE	5.08 cm (2")	5.08 cm (2")	7.62 cm (3")
BOTTOM	FURNACE (COMBUSTIBLE FLOOR WITH SUB-BASE †)	Ø	* Ø	** Ø
FLUE PIPE	HORIZONTALLY OR BELOW FLUE PIPE	10.16 cm (4")	10.16 cm (4")	10.16 cm (4")
	VERTICALLY ABOVE FLUE PIPE	22.86 cm (9")	22.86 cm (9")	22.86 cm (9")
FRONT	FURNACE	20.32 cm (8")	20.32 cm (8")	60.96 cm (24")

† When used with floor base model: \*DFB-101 or \*\*HFB-101

**FIGURE 7.2**  
**Models: AMP & NOMF 120 / 155 / 156**

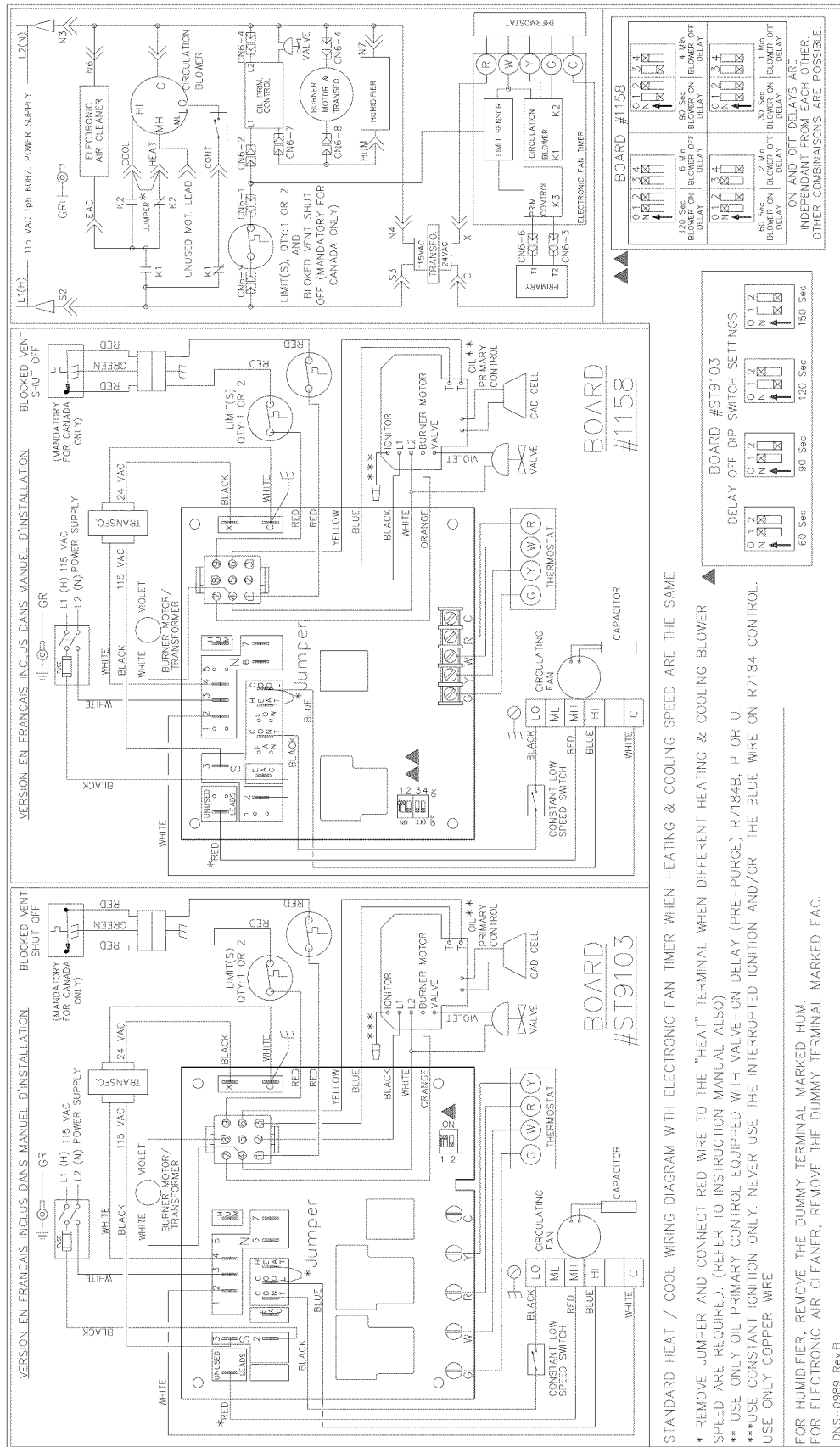

**TABLE 5.2**  
**Minimum clearances to combustible materials**

LOCATION	APPLICATION	UPFLOW	DOWNFLOW	HORIZONTAL
SIDES	FURNACE	Ø	5.08 cm (2")	5.08 cm (2")
	SUPPLY PLENUM WITHIN 6 ft. OF FURNACE	2.54 cm (1")	5.08 cm (2")	2.54 cm (1")
BACK	FURNACE	Ø	2.54 cm (1")	Ø
TOP	FURNACE OR PLENUM	5.08 cm (2")	5.08 cm (2")	5.08 cm (2")
	HORIZONTAL WARM AIR DUCT WITHIN 6 ft. OF FURNACE	5.08 cm (2")	5.08 cm (2")	7.62 cm (3")
BOTTOM	FURNACE (COMBUSTIBLE FLOOR WITH THE SUB-BASE †)	Ø	* Ø	** Ø
FLUE PIPE	HORIZONTALLY OR BELOW FLUE PIPE	10.16 cm (4")	10.16 cm (4")	10.16 cm (4")
	VERTICALLY ABOVE FLUE PIPE	22.86 cm (9")	22.86 cm (9")	22.86 cm (9")
FRONT	FURNACE	20.32 cm (8")	20.32 cm (8")	60.96 cm (24")

† When used with floor base model: \*DFB-101 or \*\*HFB-101

**FIGURE 8.1**  
**Wiring diagram, Beckett burner**



STANDARD HEAT / COOL WIRING DIAGRAM WITH ELECTRONIC FAN TIMER WHEN HEATING & COOLING SPEED ARE THE SAME

\* REMOVE JUMPER AND CONNECT RED WIRE TO THE "HEAT" TERMINAL WHEN DIFFERENT HEATING & COOLING BLOWER SPEED ARE REQUIRED. (REFER TO INSTRUCTION MANUAL ALSO)

\*\* USE ONLY OIL PRIMARY CONTROL EQUIPPED WITH VALVE-ON DELAY (PRE-PURGE) R7184B, P OR U.

\*\*\*USE CONSTANT IGNITION ONLY. NEVER USE THE INTERRUPTED IGNITION AND/OR THE BLUE WIRE ON R7184 CONTROL. USE ONLY COPPER WIRE

FOR HUMIDIFIER, REMOVE THE DUMMY TERMINAL MARKED HUM.  
FOR ELECTRONIC AIR CLEANER, REMOVE THE DUMMY TERMINAL MARKED EAC.

DNS--0989 Rev.B



FIGURE 8.2

Wiring diagram, Riello 40-F or BF burner (without 24 VAC control)

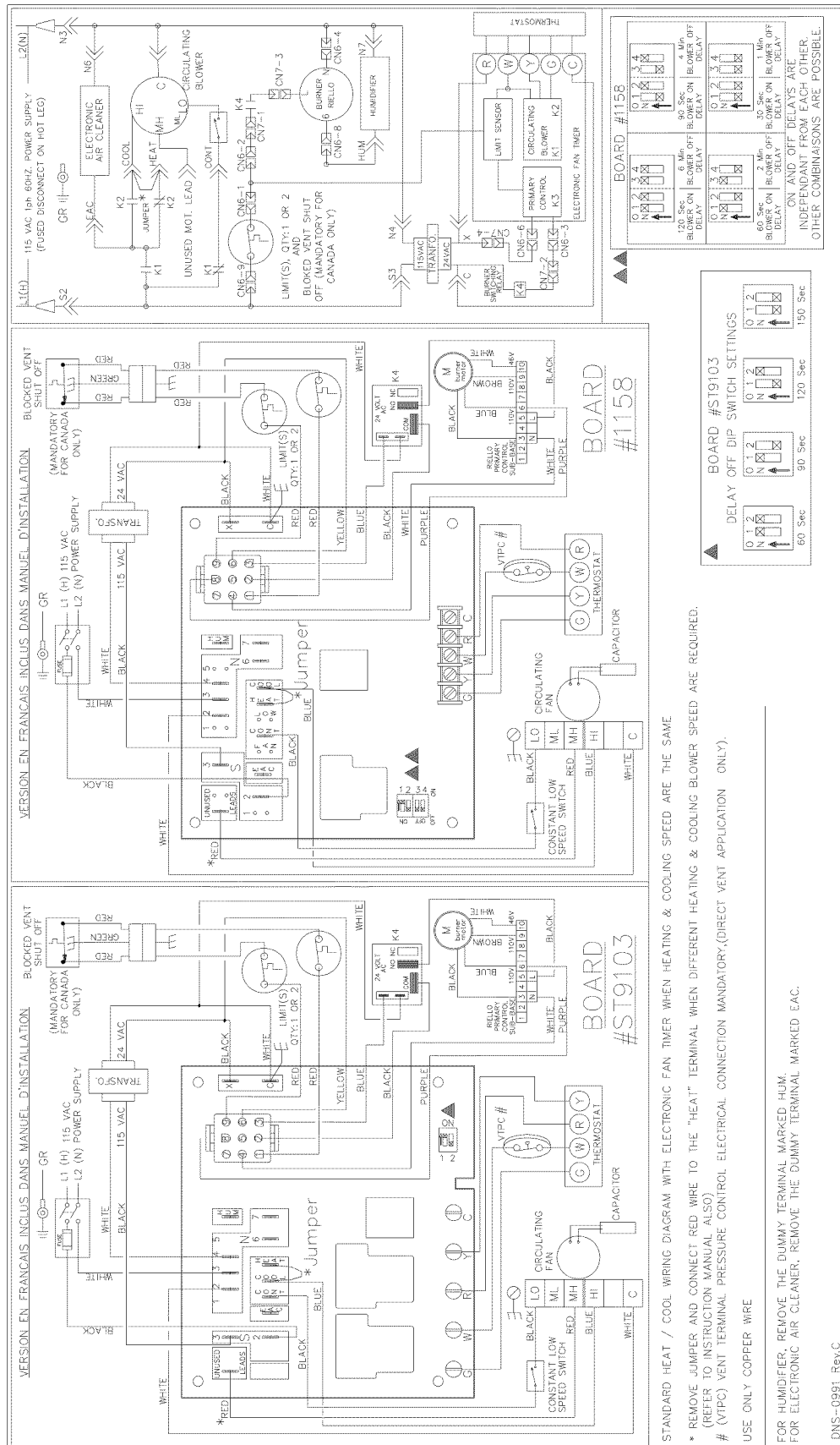

**FIGURE 8.3**

**Wiring diagram, Riello 40-F or BF burner (with 24 VAC control)**

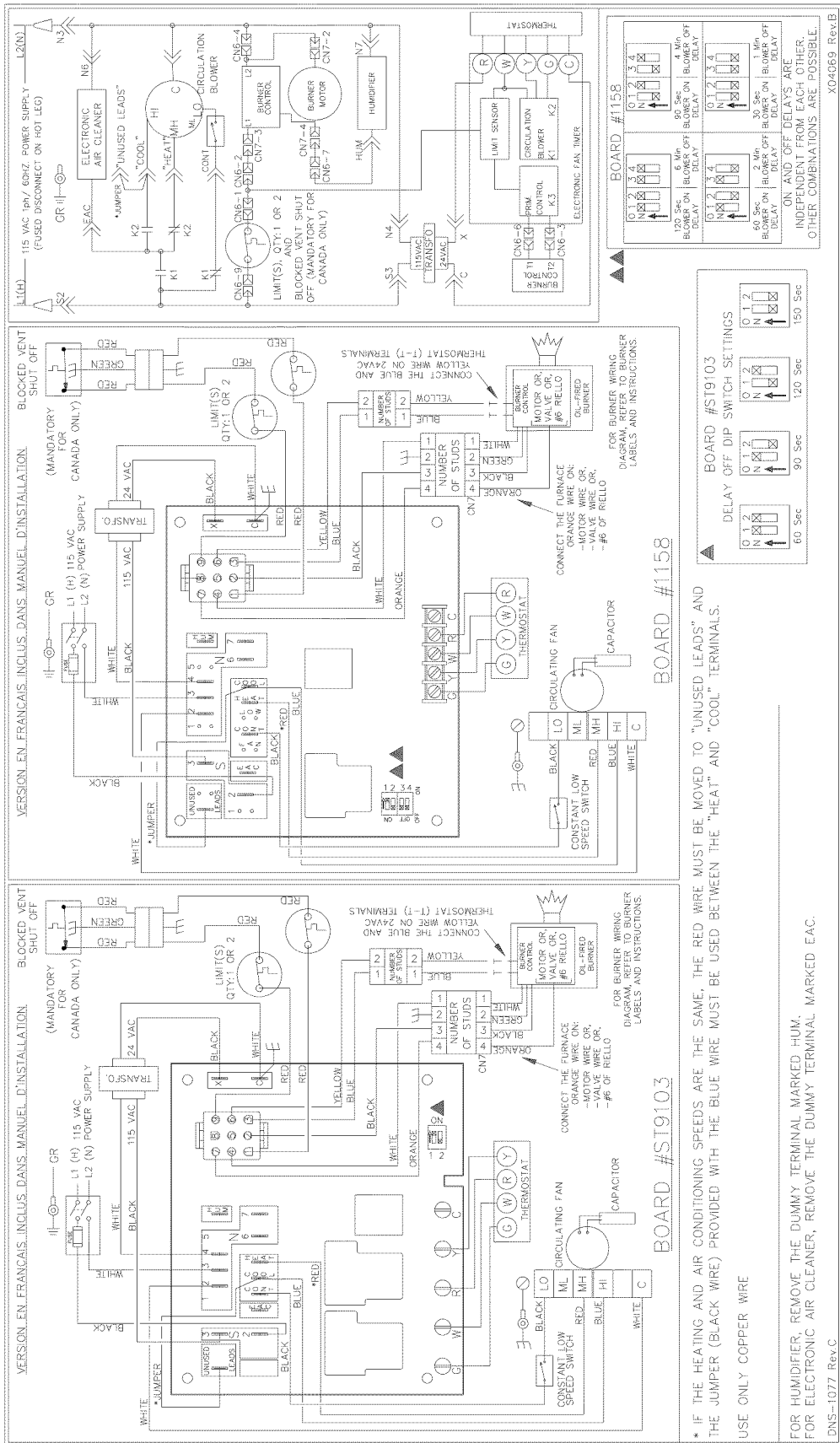

# PARTS LIST

Models : AMP & NOMF 105 / 106, Beckett AFG and 40-F Riello burner (without 24 VAC control)

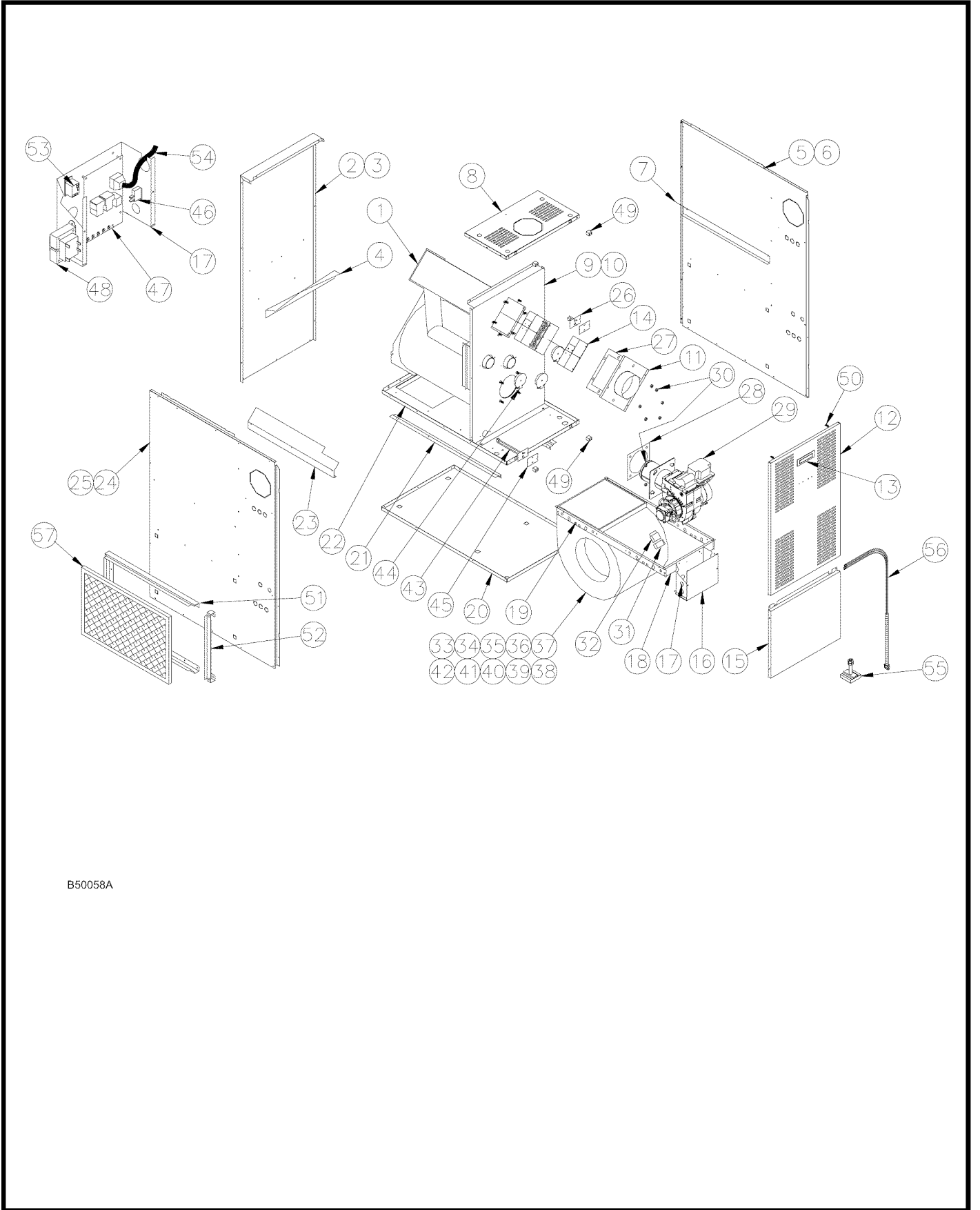

B50058A

**PARTS LIST**

**Models : AMP & NOMF 105 / 106, Beckett AFG and 40-F Riello burner (without 24 VAC control)** ←

ITEM	DESCRIPTION	PART #	COMMENTS
1	HEAT EXCHANGER	B01667	
2	REAR PANEL ASSEMBLY	B01728	Includes panel, insulation and baffle
3	INSULATION, REAR PANEL	B01986	
4	REAR BAFFLE	B01898	
5	PANEL ASSEMBLY, RIGHT SIDE	B01885-01	Includes panel, insulation and baffle
6	INSULATION, SIDE PANEL	B01645-01	
7	RIGHT LATERAL BAFFLE	B01679-01	
8	FRONT TOP PANEL ASSEMBLY	B01861	Includes panel and latch
9	FRONT DIVIDER PANEL ASSEMBLY	B01727	Includes panel, insulation and label
10	INSULATION, FRONT PANEL	B01646	
11	BREECH PLATE	B01697	
12	FRONT DOOR ASSEMBLY	B01882-08	Includes panel, label, latch and handle
13	RECESSED HANDLE, BLACK	Z99F050	
14	BAFFLE ASSEMBLY	B01676	Includes baffle and insulation
15	BLOWER DOOR	B01883-05	Includes door and label
16	ELECTRICAL BOX COVER	B01684	
17	ELECTRICAL BOX	B01683	
18	ELECTRICAL BOX SUPPORT	B01682	
19	BLOWER RAIL	B01681	2 required
20	FLOOR	B01687	
21	BLOWER RAIL	B01680	
22	BLOWER DIVIDER	B01846	Panel only
23	LEFT LATERAL BAFFLE	B01679-02	
24	LEFT SIDE PANEL ASSEMBLY	B01885-02	Includes panel, insulation and baffle
25	INSULATION, LEFT SIDE PANEL	B01645-02	
26	HIGH LIMIT 195-30F	R02R003	
27	GASKET, SMOKE BOX COVER	B01214	
28	GASKET, FIXED BREECH, BECKETT	N04Z026	
29A	BURNER ASSEMBLY	B03091-01	
29B	BURNER, RIELLO 40 F3	N01F011	
30	HEXAGONAL NUT, 3/8-16NC ZINC	F07F011	
31	CAPACITOR HOLDER	B01024	
32	CAPACITOR 5 MF	L01I001	
33	MOTOR SUPPORT ASSEMBLY, 1/3 HP	B01890-01	Includes motor and legs
34A	REPLACEMENT BLOWER ASSEMBLY	B01405-01	Includes blower, motor and capacitor
34B	BLOWER, GT10-10DD	Z01I004	Includes wheel and housing
35	BLOWER WHEEL, GT10-10DD	Z01L002	
36	MOTOR SUPPORT, TRIANGLE BAND	Z01F012	
37	MOTOR SUPPORT, TRIANGLE LEG	Z01F013	
38	SCREW, #F HEX WASHER, 1/4-20 x 1 1/4	F03F023	
39	WASHER, 1/4" BOLT ZINC BB	F06F010	
40	HEX LOCKNUT "K-LOCK" 1/4-20NC	F07J001	
41	HEX BOLT 1/4-20 x 1 1/2 ZINC FULL THREAD	F05F015	
42	BELLY BAND ASSEMBLY	B01888	
43	HIGH LIMIT 140F, 7" STEM	R02R002	
44	OBSERVATION DOOR	B02111	
45	ELECTRICAL INSULATING BARRIER	A00284	
46	ROCKER SWITCH, SPST	L07F003	
47	ELECTRONIC BOARD	R99G004	
48	TRANSFORMER 120V-24Volts, 40VA	L01F009	
49	LATCH ASSEMBLY, FEMALE	Z99F003	
50	LATCH ASSEMBLY, MALE	Z99F038	
51	FILTER RACK FRAME	B01695	
52	FILTER RACK ACCESS	B01696	
53	RELAY, SPDT 24 VAC	L01H009	
54	ELECTRICAL KIT	B00203	
55	BLOCKED VENT SHUT-OFF BVSO-225	Z06G001	
56	BVSO ELECTRICAL KIT	B03341-01	
57	PAPER FILTER 16" x 24" x 1"	Z04F007	

L50058A

# PARTS LIST

→ Models : AMP & NOMF 120 / 155 / 156, Beckett AFG and Riello 40-F burner (without 24 VAC control)

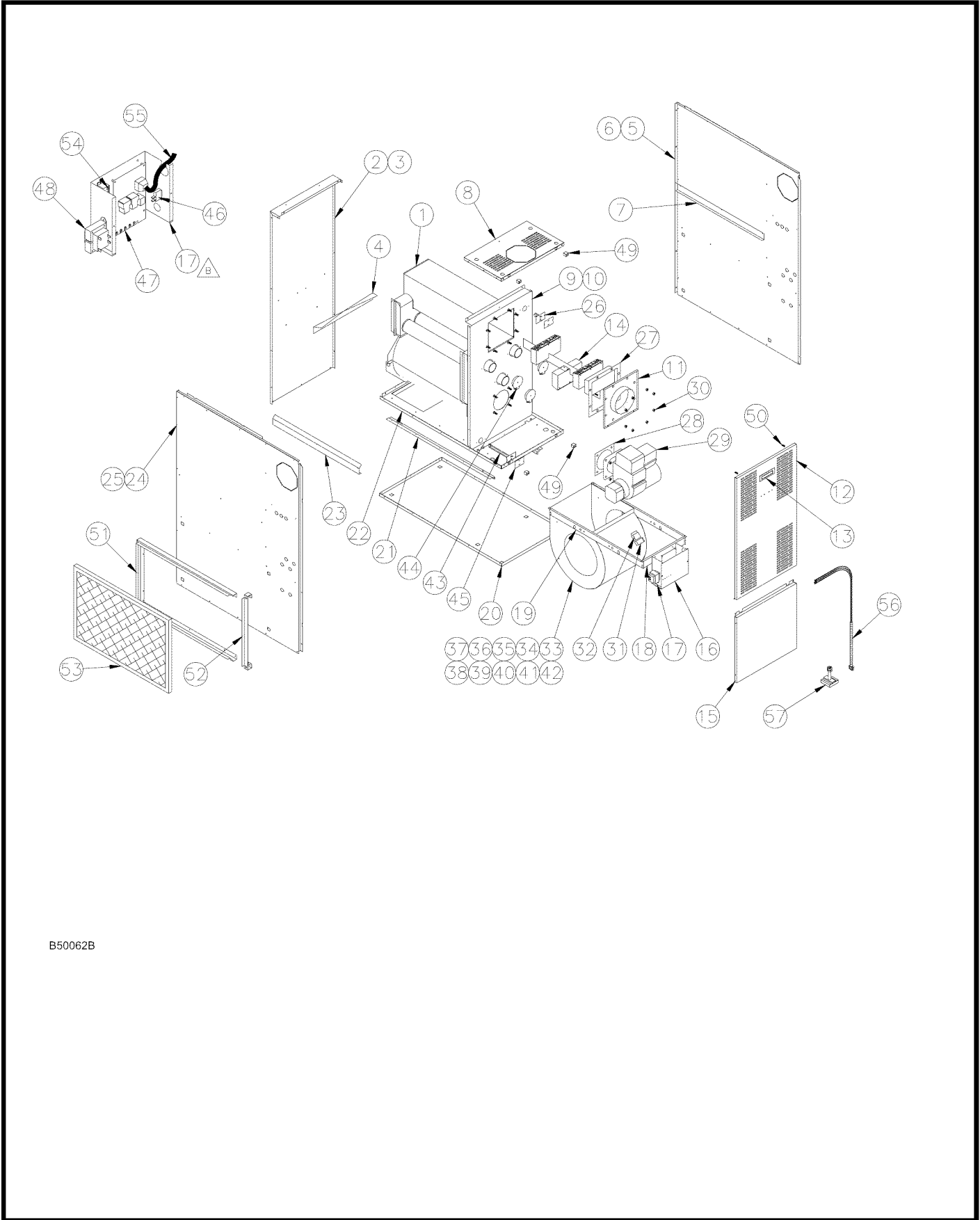

B50062B

## PARTS LIST

Models : AMP & NOMF 120 / 155 / 156, Beckett AFG and Riello 40-F burner (without 24 VAC control) ←

ITEM	DESCRIPTION	PART #	COMMENTS
1	HEAT EXCHANGER	B01787	
2	REAR PANEL ASSEMBLY	B01877	Includes panel, insulation and baffle
3	INSULATION	B01526-25	
4	REAR BAFFLE	B01988	
5	PANEL ASSEMBLY, RIGHT SIDE	B01875-01	Includes panel, insulation and baffle
6	INSULATION, SIDE PANEL	B01800-01	
7	TOP LATERAL BAFLE	B01805	
8	FRONT TOP PANEL ASSEMBLY	B01874	Includes panel and latch
9	FRONT DIVIDER PANEL ASSEMBLY	B01878	Includes panel, insulation and label
10	INSULATION, FRONT DIVIDER	B01853	
11	BRECH PLATE 6"	B01747	Chimney vent application
12	FRONT DOOR	B01852	Includes panel, label, latch and handle
13	RECESSED HANDLE, BLACK	Z99F050	
14	BAFFLE ASSEMBLY	B01751	Includes baffle and insulation
15	BLOWER DOOR ASSEMBLY	B01873-05	Includes door and label
16	ELECTRICAL BOX COVER	B01684	
17	ELECTRICAL BOX	B01683	
18	ELECTRICAL BOX SUPPORT	B01682	
19	BLOWER RAIL	B01681	2 required
20	FLOOR	B01804	
21	BLOWER RAIL	B01794	2 required
22	BLOWER DIVIDER	B01795	Panel only
23	LEFT LATERAL DEFLECTOR	B01805-02	
24	LEFT SIDE PANEL ASSEMBLY	B01875-02	Includes panel, insulation and baffle
25	INSULATION, LEFT SIDE PANEL	B01800-02	
26	HIGH LIMIT 175-20F	R02R005	
27	GASKET, SMOKE BOX COVER	B00205	
28	GASKET, FIXED BREECH, BECKETT	N04Z026	
29A	BURNER BECKETT AFG-F3	B03092-01	
29B	BURNER, RIELLO 40-F5	N01F012	
30	HEXAGONAL NUT, 3/8-16NC ZINC	F07F011	
31	CAPACITOR HOLDER	B01024	
32	CAPACITOR 15 MF	L01I005	
33	MOTOR 3/4 DD 4V	L06I004	
34A	REPLACEMENT BLOWER ASSEMBLY	B01406-01	Includes blower, motor and capacitor
34B	BLOWER GT12-10DD	Z01I008	
35	BLOWER WHEEL GT12-10DD	Z01L003	
36	MOTOR SUPPORT, TRIANGLE BAND	Z01F012	
37	MOTOR SUPPORT, TRIANGLE LEG	Z01I009	
38	SCREW, #F HEX WASHER, 1/4-20 x 1 1/4	F03F023	
39	WASHER, 1/4" BOLT ZINC BB	F06F010	
40	HEX LOCKNUT "K-LOCK" 1/4-20NC	F07J001	
41	HEX BOLT 1/4-20 x 1 1/2 ZINC FULL THREAD	F05F015	
42	BELLY BAND ASSEMBLY	B01889	
43	HIGH LIMIT 140F, 7" STEM	R02R002	
44	OBSERVATION DOOR ASSEMBLY	B02111	
45	ELECTRICAL INSULATING BARRIER	A00284	
46	ROCKER SWITCH, SPST	L07F003	
47	ELECTRONIC BOARD	R99G004	
48	TRANSFORMER 120V-24Volts, 40VA	L01F009	
49	LATCH ASSEMBLY, FEMALE	Z99F003	
50	LATCH ASSEMBLY, MALE	Z99F038	
51	FILTER RACK FRAME	B01809	
52	FILTER RACK ACCESS	B01808	
53	PAPER FILTER 20" x 30" x 1"	Z04F013	
54	RELAY, SPDT 24 VAC	L01H009	
55A	ELECTRICAL KIT	B00203	
55B	ELECTRICAL KIT, RIELLO	B02329	
56	BVSO ELECTRICAL KIT	B03341-01	
57	BLOCKED VENT SHUT-OFF BVSO-225	Z06G001	

L50062A

PARTS LIST

Models : AMP & NOMF 120 / 156, Riello 40-F burner (with 24 VAC control)

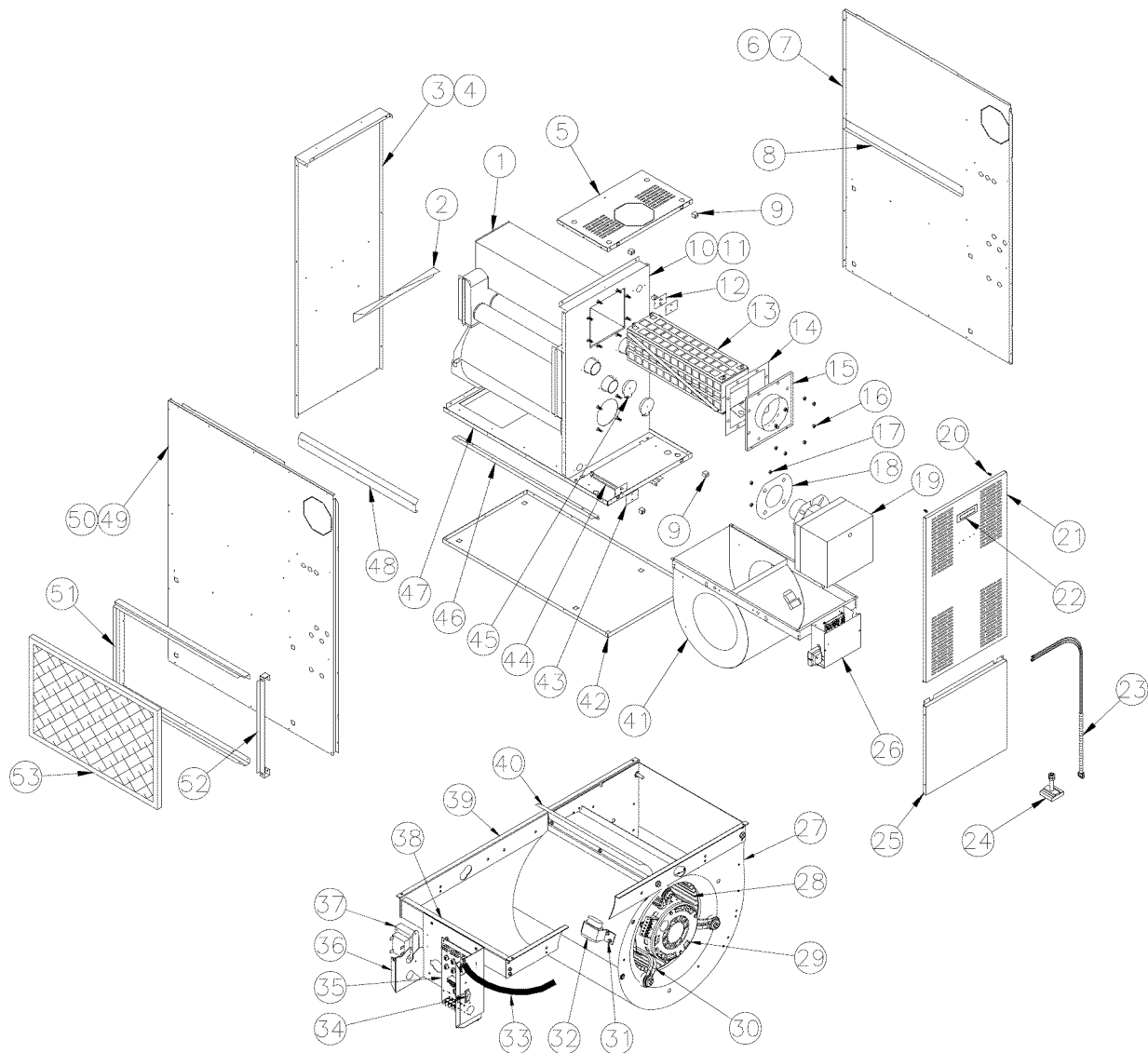

B50085A

## PARTS LIST

Models : AMP & NOMF 120 / 156, Riello 40-F burner (with 24 VAC control) ←

Item	Part	Description	Comments
1	B01787	HEAT EXCHANGER ASSEMBLY	BAFFLE AND GASKETS NOT INCLUDED
2	B01988	REAR BAFFLE	
3	B01877	REAR PANEL ASSEMBLY	INCLUDES PANEL, INSULATION AND BAFFLE
4	B01526-25	INSULATION	
5	B01874	FRONT TOP PANEL ASSEMBLY	INCLUDES PANEL AND LATCH
6	B01800-01	SIDE PANEL INSULATION	
7	B01875-01	RIGHT SIDE PANEL ASSEMBLY	INCLUDES PANEL, INSULATION AND BAFFLE
8	B01805-01	RIGHT SIDE BAFFLER	
9	Z99F003	LATCHE ASSEMBLY, FEMALE	
10	B01878	FRONT DIVIDER PANEL ASSEMBLY	INCLUDES PANEL, INSULATION AND BABELS
11	B01853	FRONT SEPARATOR INSULATION	
12	R02R005	HIGH LIMIT 175-20F 1 3/4"	
13	B03598	SOUND TRAP ASSEMBLY	INCLUDES BAFFLE AND INSULATION
14	B00205	GASKET, FLUE OUTLET FLANGE	
15	B01747	FLUE OUTLET FLANGE 6" DIA.	
16	F07O001	HEX FLANGE NUT 3/8-16NC LAITON	
17	F07F011	HEX NUT 3/8-16NC ZINC	
18	N04Z024	GASKET BURNER FLANGE	
19	N01F045	BURNER RIELLO 40-F5	
20	Z99F038	LATCHE, MALE	
21	B01852	FRONT DOOR	DOOR ONLY
22	Z99F050	RECESSED HANDLE, BLACK	
23	B03341-01	BVSO ELECTRICAL KIT	
24	Z06G001	BLOCKED VENT SHUT-OFF BVSO-225	
25	B01873-05	BLOWER DOOR ASSEMBLY	INCLUDES DOOR AND LABEL
26	B01684	ELECTRICAL BOX COVER	
27	Z01I008	BLOWER GT12-10DD	INCLUDES WHEEL AND HOUSING
28	Z01L003	WHEEL G12-10DD	
29	L06I004	MOTOR 3/4 DD 4S	
30	B01889	MOTOR SUPPORT ASSEMBLY	INCLUDES LEGS, BAND AND FASTENERS
31	B01024	CAPACITOR HOLDER	
32	L01I005	CAPACITOR 15 MF	
33	B03319	ELECTRICAL KIT, RIELLO	
34	L07F003	ROCKER SWITCH SPST	
35	R99G004	ELECTRONIC BOARD 1158-110	
36	B01683	ELECTRICAL BOX	
37	L01F009	TRANSFORMER 120-24Volts, 40VA	
38	B01682	ELECTRICAL BOX BRAQUET	
39	B01681	BLOWER SLIDE RAIL	2 REQUIRED
40	B01291-01	SEAL STRIP 1 1/2" X 13 1/8"	
41	B01406-01	REPLACEMENT BLOWER ASSEMBLY	INCLUDES BLOWER, MOTOR AND CAPACITOR
42	B01804	FLOOR	
43	A00284	HIGH LIMIT PROTECTIVE SHIELD	
44	R02R002	LIMIT CONTROL 140F, 7"	
45	B02111	OBSERVATION DOOR ASSEMBLY	
46	B01794	BLOWER SLIDE SUPPORT	2 REQUIRED
47	B01795	BLOWER DIVIDER	PANEL ONLY
48	B01805-02	LEFT SIDE BAFFLE	
49	B01875-02	LEFT SIDE PANEL ASSEMBLY	INCLUDES PANEL, INSULATION AND BAFFLE
50	B01800-02	SIDE PANEL INSULATION	
51	B01809	FILTER RACK FRAME	
52	B01808	FILTER RACK ACCESS	
53	Z04F013	PAPER FILTER 20 X 30 X 1	

L50085A



**PARTS LIST**  
**Model : AMP120, Riello 40-BF burner**

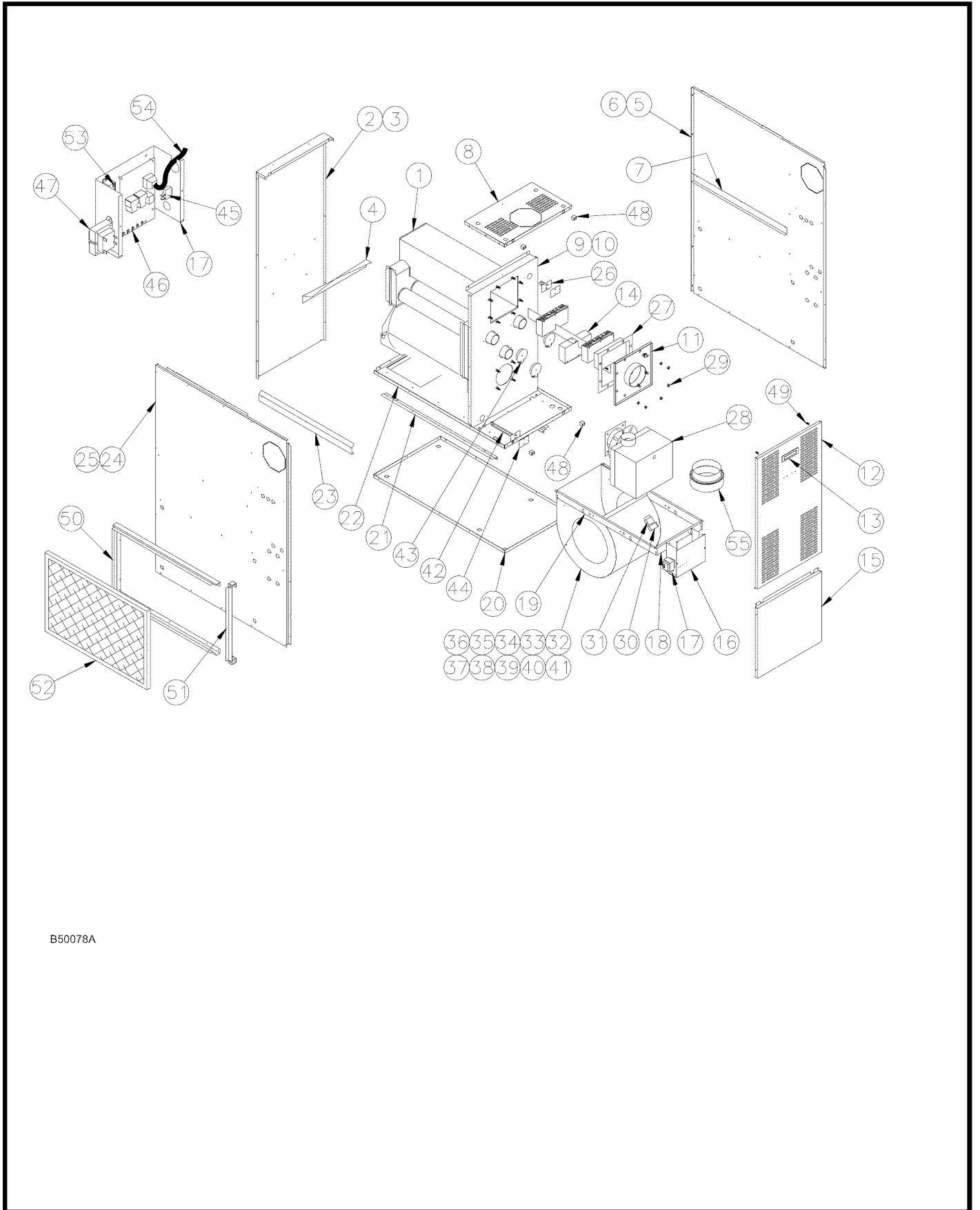

B50078A

## PARTS LIST

Model : AMP120, Riello 40-BF burner

ITEM	DESCRIPTION	PART #	COMMENTS
1	HEAT EXCHANGER	B01787	
2	REAR PANEL ASSEMBLY	B01877	Includes panel, insulation and baffle
3	INSULATION	B01526-25	
4	REAR BAFFLE	B01988	
5	PANEL ASSEMBLY, RIGHT SIDE	B01875-01	Includes panel, insulation and baffle
6	INSULATION, SIDE PANEL	B01800-01	
7	RIGHT LATERAL BAFFLE	B01805-01	
8	FRONT TOP PANEL ASSEMBLY	B01874	Includes panel and latch
9	FRONT DIVIDER PANEL ASSEMBLY	B01878	Includes panel, insulation and label
10	INSULATION, FRONT DIVIDER	B01853	
11	SMOKE OUTLET ASSEMBLY	B03509	
12	FRONT DOOR	B01852	Includes panel, label, latch and handle
13	RECESSED HANDLE, BLACK	Z99F050	
14	BAFFLE ASSEMBLY	B01751	Includes baffle and insulation
15	BLOWER DOOR ASSEMBLY	B01873-05	Includes door and label
16	ELECTRICAL BOX COVER	B01684	
17	ELECTRICAL BOX	B01683	
18	ELECTRICAL BOX SUPPORT	B01682	
19	BLOWER RAIL	B01681	2 required
20	FLOOR	B01804	
21	BLOWER RAIL	B01794	2 required
22	BLOWER DIVIDER	B01795	Panel only
23	LEFT LATERAL DEFLECTOR	B01805-02	
24	LEFT SIDE PANEL ASSEMBLY	B01875-02	Includes panel, insulation and baffle
25	INSULATION, LEFT SIDE PANEL	B01800-02	
26	HIGH LIMIT 175-20F	R02R005	
27	GASKET, SMOKE BOX COVER	B00205	
28	BURNER RIELLO 40-BF5	N01F010	
29	HEXAGONAL NUT 3/8-16NC ZINC	F07F011	
30	CAPACITOR HOLDER	B01024	
31	CAPACITOR 15 MF	L01I005	
32	MOTOR 3/4 DD 4V	L06I004	
33A	REPLACEMENT BLOWER ASSEMBLY	B01406-01	Includes blower, motor and capacitor
33B	BLOWER GT12-10DD	Z01I008	
34	BLOWER WHEEL G12-10DD	Z01L003	
35	MOTOR SUPPORT, TRIANGLE BAND	Z01F012	
36	MOTOR SUPPORT, TRIANGLE LEG	Z01I009	
37	SCREW, #F HEX WASHER 1/4-20X1 1/4	F03F023	
38	WASHER, 1/4" BOLT ZINC BB	F06F010	
39	HEX LOCKNUT "K-LOCK" 1/4-20NC	F07J001	
40	HEX BOLT 1/4-20 X 1 1/2 ZINC FULL THREAD	F05F015	
41	BELLY BAND ASSEMBLY	B01889	
42	HIGH LIMIT 140F, 7" STEM	R02R002	
43	OBSERVATION DOOR ASSEMBLY	B02111	
44	ELECTRICAL INSULATING BARRIER	A00284	
45	ROCKER SWITCH, SPST	L07F003	
46	ELECTRONIC BOARD	R99G002	
47	TRANSFORMER 120-24Volts, 40VA	L01F009	
48	LATCH ASSEMBLY, FEMALE	Z99F003	
49	LATCH ASSEMBLY, MALE	Z99F038	
50	FILTER RACK FRAME	B01809	
51	FILTER RACK ACCESS	B01808	
52	PAPER FILTER 20" x 30" x 1"	Z04F013	
53	RELAY, SPDT 24 VAC	L01H009	
54	ELECTRICAL KIT, RIELLO	B02329	
55	REDUCER PIPE 7@6 GALV 28 GA	Z07F011	

L50078A