



ViVOPay™ VP6300 User Manual



80154502-001 Rev. A



Copyright

Copyright© 2017, International Technologies and Systems Corporation. All rights reserved.

ID TECH
10721 Walker Street
Cypress, CA 90630
USA

This document, as well as the hardware and software it describes, is furnished under license and may only be used in accordance with the terms of such license. The content of this paper is furnished for informational use, subject to change without notice, and not to be construed as a commitment by ID TECH. ID TECH assumes no responsibility or liability for any errors or inaccuracies that may appear in this document.

Except as permitted by such license, no part of this publication may be reproduced or transmitted by electronic, mechanical, recorded, or any other method, or translated into another language or language form without the express written consent of ID TECH. ID TECH is a registered trademark of International Technologies and Systems Corporation. ViVOPay and Value through Innovation are trademarks of International Technologies and Systems Corporation. Other trademarks are the property of the respective owner.

Warranty Disclaimer: The services and hardware are provided "as is" and "as-available," and the use of these services and hardware are at the user's own risk. ID TECH does not make, and hereby disclaims, any and all other express or implied warranties, including, but not limited to warranties of merchantability, title, fitness for a particular purpose, and any warranties arising from any course of dealing, usage, or trade practice. ID TECH does not warrant that the services or hardware will be uninterrupted, error-free, or completely secure.

FCC Regulatory Compliance

Notices Class B Equipment

This equipment has been tested and found to comply with the limits for a Class B digital device pursuant to Part 15 of the FCC Rules. These limits are designed to provide reasonable protection against harmful interference in a residential installation. This equipment generates, uses, and can radiate radio frequency energy and, if not installed and used in accordance with the instructions, may cause harmful interference to radio communications. However, there is no guarantee that interference will not occur in a particular installation. This device complies with part 15 of the FCC rules. Operation is subject to two conditions: (1) This device may not cause harmful interference, and (2) this device must accept any interference received, including interference that may cause undesired operation.

If this equipment does cause harmful interference to radio or television reception, which can be determined by turning the equipment off and on, the user is encouraged to try and correct the interference by one or more of the following measures:

- Reorient or relocate the receiving antenna.
- Increase the separation between the equipment and the receiver.
- Connect the equipment into an outlet on a circuit different from that to which the receiver is connected.
- Consult the dealer or an experienced radio/TV technician for help.
- Changes or modifications to the ViVOPay VP6300 not expressly approved by ID TECH could void the user's authority to operate the ViVOPay VP6300.

IC Compliance Warning

Operation is subject to two conditions: (1) This device may not cause harmful interference, and (2) this device must accept any interference received, including interference that may cause undesired operation.

Cautions and Warnings



	Caution: The ViVOPay VP6300 should be mounted 1-2 feet away from other ViVOPay VP6300 units. Can be adjusted based on lane setup.
	Caution: Danger of Explosion if battery is incorrectly replaced. Replace only with same or equivalent type recommended by the manufacturer. Discard used batteries according to the manufacturer's instructions.
	Warning: Avoid close proximity to radio transmitters which may reduce the ability of the reader.

Table of Contents

1. Overview	5
1.1 Features	7
1.2 ViVOpay VP6300: Approvals	8
1.3 ViVOpay VP6300: Firmware	8
1.4 ViVOpay VP6300: Physical/Mechanical Characteristics	10
1.5 ViVOpay 6300: Durability and Reliability Specs	11
1.6 ViVOpay VP6300: Electrical Power Characteristics	11
1.7 ViVOpay VP6300: Environmental Characteristics	11
1.8 ViVOpay VP6300 Contactless Specifications	12
1.9 ViVOpay VP6300 Contact EMV Specifications	12
1.10 ViVOpay VP6300 MSR Specifications	12
1.11 ViVOpay VP6300 Connectivity	13
2. VP6300 Overall Layout	14
3. VP6300 Installation	14
3.1 Custom Wiring	15
3.2 Parts List	16
3.3 Installation of Reader	16
3.4 Connecting to Power	18
3.5 Using the ViVOpay VP6300 to Make a Purchase	18
Presenting Cards or NFC Phones	18
4. Installation Points	18
5. RF Interference	19
6. Firmware Upgrade	20
Preparation	20
7. Troubleshooting	23
8. CFR 15.19 - Labeling requirements	25

1. Overview

ID TECH's ViVOpay VP6300 is a compact 3-in-1 credit card reader designed to support MSR (magstripe), contact EMV, and contactless card reading (using NFC and/or RFID).

The ViVOpay VP6300 is designed to deliver MSR, EMV, and contactless payment acceptance in unattended payment scenarios, such as Parking, Fueling, ATM, Ticketing, and Payment Kiosks. Through the integrated, high-contrast color digital display, customers can be guided to tap, insert or swipe to complete transactions using MasterCard PayPass, Visa VCPS, American Express ExpressPay, Discover. The unit supports all popular digital wallet technologies, including Apple Pay (including Apple VAS), Android Pay, Google Smart Tap, and Samsung Pay.

The ViVOpay VP6300 is certified to the latest payment standards of EMV (Level 1 and Level 2) and PCI (5.x), and comes in an SRED version for scenarios requiring the tamper resistance and other requirements of SRED.



The ViVOpay VP6300

The ViVOpay VP6300 supports USB and serial (RS-232) host communication using the command protocol defined in the *NEO Interface Developers Guide*. This comprehensive guide describes all of the firmware commands and other features available in ID TECH's contactless payment devices; it is the authoritative source for technical information of interest to systems integrators. (Contact your ID TECH representative to obtain a copy of this guide, which is available under NDA.) Note, also, that a feature-rich, Windows-based Universal SDK is available to aid in rapid development of applications that talk to the VP6300.

Be sure to check the Downloads link on the ID TECH public Knowledge Base at <https://atlassian.idtechproducts.com/confluence/display/KB/Knowledge+Base+-+Home> for the latest VP6300 demos, utilities, SDK updates, white papers, and other downloads, all of which are freely available without registration.

VP6300 PCI/EMV Certified 3-in-1 Reader

Model Number	Description
IDVV-580801	Unattended hybrid vending reader (non-SRED); 0 SAM; TDES; AMDV + Wallet overlay
IDVV-580821	Unattended hybrid vending reader (non-SRED); 2 SAM; TDES; AMDV + Wallet overlay
IDVV-581801P	Unattended hybrid vending reader; SRED; 0 SAM; TDES; AMDV + Wallet overlay
IDVV-581821P	Unattended hybrid vending reader SRED; 2 SAM; TDES; AMDV + Wallet overlay

Optional Accessories

Model Number	Description
80139201-001	Evaluation Cable
220-0012-00	USB Cable (goes with the Eval cable)
220-2463-00	RS232 Cable (connects with Eval cable)
140-2035-00	USA Power Supply

1.1 Features

The ViVOPay VP6300 supports the following:

- Contactless: ISO/IEC 14443 Type A and B
- ISO 18092 peer-to-peer communication
- LEDs:
 - 4 green LEDs at the top
 - 1 tri-color LED indicator for MSR
 - LED indicator for Contact Chip at the Bottom
- RS232 & USB connectivity options
- Programmable beeper for audible cues
- Tamper detection (SRED models only) with automatic data zeroization
- Available with or without 2 SAMs
- Bidirectional magnetic stripe reading of up to 3 tracks of data
- JIS-1 and JIS-II support
- ICC reader (bottom-facing insert slot) with landing contact
- Contact and Contactless EMV Level 1 and 2 certified
- Uses ID TECH's proven Common Kernel, for EMV L2 compatibility
- Encrypted MSR, contact, and contactless EMV output, with DUKPT key management
- TR34 Remote Key Injection Protocol
- Quick Chip and M/Chip Fast compatibility for rapid contact EMV (less than 2 seconds)
- USB or RS-232 (for data communication)
- 1 year manufacturer warranty

1.2 ViVOpay VP6300: Approvals

Item	Regulation & Class
CE	EN55032/EN55035, Class- B
FCC	Part 15, Class-B
RoHS	2002/95/EC
UL	Compliance with UL regulations
REACH	Compliance with REACH regulations
USB IF	Compliance with USB IF regulations
EMV	Contact L1 & L2 / Contactless L1 & L2
American Express	American Express® ExpressPay 3.1
Discover	Discover® DPAS 1.0 Zip 3.1.2
MasterCard	MasterCard® Mchip 3.1.1
Visa	Visa VCPS 2.2
Interac	Interac 1.5d
CUP	qPBOC 3.0
JCB	JCB
PCI	PCI PTS 5.X Certified
OTHERS	Apple Pay Apple VAS Android Pay Google Smart Tap 2.1

1.3 ViVOpay VP6300: Firmware

Feature	Support Function
Magnetic stripe	Meets ISO 7810/ISO 7811 specification Supports AAMVA format Supports JIS I/II card format Supports single, dual and triple tracks. Bi-directional reading
Contactless	EMVCo Contactless Level 1/2 ISO 14443 Type A&B, Mifare, ISO 18092 (including P2P) Visa: VCPS 2.2 or later (MSD and qVSDC)

	<p>IRWIN listed</p> <p>Visa Transit extensions</p> <p>MasterCard: M/Chip 3.1 or later</p> <p>American Express: ExpressPay 3.1</p> <p>Discover: DPAS latest version</p> <p>Interac: Flash version 1.5d</p> <p>PBOC: level 1 and 2</p> <p>MiFare: Classic, Ultralight C, DESFire, DESFire EV1</p> <p>JCB Level 2</p> <p>China Union Pay (CUP)</p> <p>Sony Felica Support (Japan/Asia)</p> <p>Android Pay Support</p> <p>Apple Pay Support</p> <p>Apple VAS</p> <p>Google Smart Tap 2.1</p> <p>Samsung Pay NFC</p> <p>Calypso electronic ticketing system support</p>
Contact	EMVCo Contact Level 1 & 2
External PIN pad	<p>Pairs with ID TECH SmartPIN L100 PIN pad for EMV L2 chip and PIN</p> <p>Uses L100 as user interface for non-payment-related functions</p>
Power Management	Low power modes: Sleep and Stop
Key injection	<p>Compatible with FutureX and Geobridge HSMs for Data Key Injection</p> <p>Can communicate with HSM via USB or RS232 port</p> <p>Support for RSA keys generation and certificates loading</p> <p>Support for Asymmetric TR-34 Remote Key Injection</p>
Security	<p>PCI PTS SRED Certified (5.x or higher)</p> <p>Supports ID TECH Encrypted Data Output Format – 80000502-001</p> <p>Support multiple encryption formats:</p> <ul style="list-style-type: none"> • TDES • AES • RSA-based TransArmor <p>Supports Multiple Key management techniques:</p> <p>DUKPT</p> <p>Master Session Key</p> <p>Secure firmware and application download using PKI</p>

	Secure commands (MAC or PKI) for configuring device (RTC, whitelist, reset device, etc.)
Command Set	Reference the <i>NEO Interface Developers Guide - 800139403-001</i>
Host Interfaces	RS232, USB-HID
Firmware/Application Download	Use host interfaces to download firmware/application
Application	Future development to supports payment applications hosted by the VP6300 to send payment packets to different gateways/processors/acquirers QSPI Flash for code storage and SDRAM for memory
Multiple hosts	Stores multiple sets of keys for different hosts
LEDs	LEDs – Green NFC Certification LED on antenna 2 diagnostic LED 1 tri-color LED indicator for MSR
Audio	Beep for contactless transaction and other functions
Logs	Keep logs for firmware/application download, secure events
Ethernet	Can connect to internet

1.4 ViVOpay VP6300: Physical/Mechanical Characteristics

Item	
Physical Dimensions	108mm x 85mm x 55mm (L x W x H)
Structural Material	PC UL 94V-0 plastic with UV stabilizer
Mounting	Four (4) #8-32 brass nuts
Housing Color	Black
Texture	MT11020
Intrusion Rating	IP54
Impact Rating	IK10
LCD display	Graphic display, 128x64 dots
LED	4 LEDs for EMV certification 1 LED for MSR indicator

	1 LED for ICC indicator 4 Blue LED vending machine
Contactless logo	Minimum size 13x22.2mm
Keypad	Two hard keys

1.5 ViVOPay 6300: Durability and Reliability Specs

Item	Specification
Magnetic Head	1,000,000 swipes minimum
Rail	1,000,000 swipes minimum
Keypad	1,000,000 operations per key
Smartcard connector	500,000 cycles minimum per connector vendor If oxidation of contact is not considered, the life can be longer.
Magnetic Head	1,000,000 swipes minimum

1.6 ViVOPay VP6300: Electrical Power Characteristics

Item	Specification	Note
Power Input: Vin	DC +7.5V~ +45V	Normal operating input range
	DC +6.5V	Absolute minimum input voltage
	DC +47V	Absolute maximum input voltage
Power Consumption	< 1A	Normal operating status

1.7 ViVOPay VP6300: Environmental Characteristics

Item	Specification	Note
Operating Temperature	-20 °C to 70 °C	1. Non-condensing. 2. Product operation temperature is limited to the range for the reason of the constraint of LCD specification.
Storage Temperature	-30 °C to 85 °C	1. Non-condensing. 2. Product storage temperature is limited to the range for the reason of the constraint of LCD specification.
Operating Humidity	5% to 95%	Non-condensing
Storage Humidity	5% to 95%	Non-condensing

ESD	Device Unit	Contact	±8kV	1. Test cable/connector must be fully isolated with insulating material to prevent ESD discharge.
		Air discharge	±12KV	
	Mag Head	Contact	±4kV	
		Air discharge	±8KV	

Note: Cables/connectors must be fully isolated with insulating material to prevent ESD discharge.

1.8 ViVOpay VP6300 Contactless Specifications

Hardware	
MTBF	500,000 hours
Receiver Subcarrier Data	ISO 14443-2 Type A: Modified Manchester ISO 14443-2 Type B: NRZ-L, BPSK ISO 18092 ISO 21481 (PCD & NFC)
Typical Read Range	4-6 cm (1.5 to 2.3 inches)
Electrical	
Working Current	<500mA(@7.5VDCIN)
Rated power	<3.8W
Maximum field strength	2.6 dBuA/m at 3 m

1.9 ViVOpay VP6300 Contact EMV Specifications

Item	Specification
Slot width	0.9mm min
Media Thickness	0.76mm (tolerance ±0.08mm)
Card Formats	ISO-7816
Contact force	0.2 to 0.6N
Technology	Friction type

1.10 ViVOpay VP6300 MSR Specifications

Item	Specification	Note
Head	Standard 3T head	
Head material	Perm alloy	
Lead Out	FPCB	
Slot width	1.5mm±0.05	
Media Thickness	0.76mm (tolerance ±0.08mm) Max 0.89mm	ISO 7810 ID-1 card

Card Formats	ISO-7811	
Media Densities	75 bpi, 210 bpi	
Media Coercivity	250 to 4200 Oersted	
Reading Direction	Bi-direction	
Swipe Speed	3 to 50 IPS	
Low Amplitude Reading	30% @210 bpi, 40% @75 bpi	

1.11 ViVOpay VP6300 Connectivity

Item	Description		
	Function	Specification	
Connector	Type	2 row lock type JST B10B-PADSS-F or equivalent	
	Number of Pins	10 pins	
Connector Pin Assignment	No	Signal	Description
	1	+5VIN	Power input: 5VDC
	2	GND_EARTH	Chassis Ground
	3	RS232TX	RS232 TX signal
	4	RS232RX	RS232 RX signal
	5	GND_EARTH	Chassis Ground
	6	GND	Power ground
	7	USB_DATA+	USB DATA+ signal
	8	USB_DATA-	USB DATA- signal
	9	VIN	Power input: 7.5 ~ 45 VDC
10	GND	Power ground	

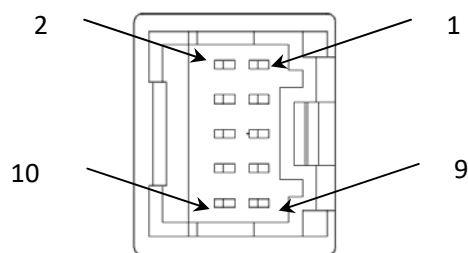

2. VP6300 Overall Layout

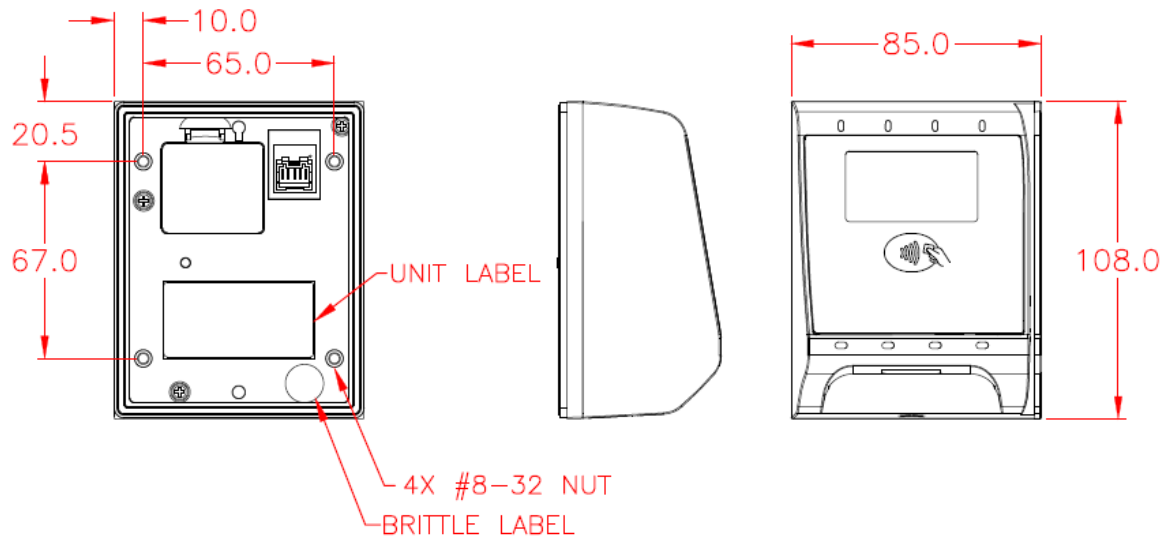

3. VP6300 Installation

This section provides information needed for installing the ViVOpay VP6300 on a mounting surface.

The drill template is as follows.

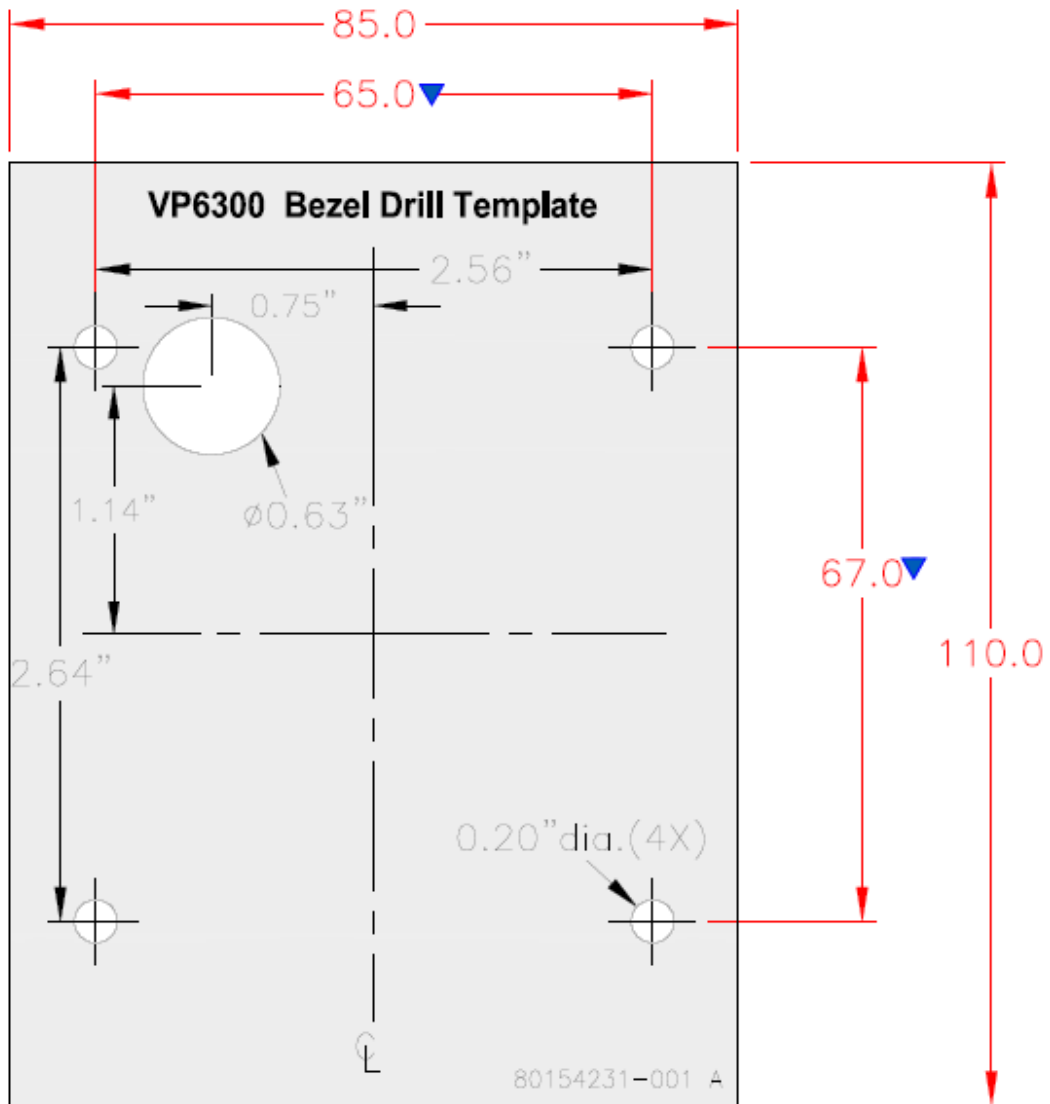

3.1 Custom Wiring

If there is a need to fabricate custom wiring for the unit, refer to the wire connection layout below.

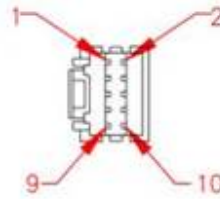

JST PADP-10V-1-S
OR APPROVED EQUIVALENT
CRIMP TERMINALS:
JST SPH-002T-P0.5L
OR APPROVED EQUIVALENT

◆ WIRE CONNECTIONS				
P2	P3	SIGNAL	COLOR	P1
	7	ISP	BLACK	1
	–			2
	1	TXD	RED	3
	2	RXD	BROWN	4
	–			5
	–			6
	4	USB D+	GREEN	7
	5	USB D–	ORANGE	8
PIN	–	DC POWER	YELLOW	9
SLEEVE	6, 8	GROUND	DRAIN 	10

3.2 Parts List

Verify that you have the following hardware for the installation of the ViVOpay VP6300:

- ViVOpay VP6300 P/N SPTP2-988-33-2C-0C or SPTP2-988-33-2CD-0C.
- (Optional) ViVOpay VP6300 NFC Antenna P/N ID-80152002-001 or ID-80152002-002. You will need this item, and its cable (P/N 80136204-001), if you will be using VP6300's contactless (NFC) capabilities.
- USB cable P/N 80152210-001, or RS-232 cable P/N 80152211-001.
- Power supply P/N 140-2035-00.

3.3 Installation of Reader

Refer to the VP6300 drawing shown further above ([Overall Layout](#)). Verify that power cords can physically reach the unit. Then proceed to:

- Locate, mark, and drill 0.20-in. holes for the main mounting points of the unit, spaced 67 mm apart lengthwise (on center), and spaced 55 mm apart (on center) along the shorter axis. Use a #12 drill.

- Secure the unit to the enclosure with bolts or screws of appropriate depth. Ensure that the gasket is compressed to a degree necessary to protect against unnecessary moisture ingress.

3.4 Connecting to Power

The VP6300 can be powered through the RS-232 communications cable or the USB Y-connector.

Connect the +7.5 to 45VDC power supply (P/N 140-2035-00) to the barrel receptacle on the RS-232 cable, or the barrel part of the Y-cable for USB, by sliding the power supply barrel into the receiving recess.

Plug the unit in to an AC outlet and verify that the VP6300 lights up.

3.5 Using the ViVOpay VP6300 to Make a Purchase

Presenting Cards or NFC Phones

The ViVOpay VP6300 allows for credit/debit card purchases using Contactless technology.

Present the card/phone in close proximity to the front portion of the module. Present the card/phone so that maximum surface area is parallel to the antenna area. The unit should beep and all four green LEDs should illuminate briefly to indicate a successful test.

This tests the antenna's ability to read the Contactless test card. If unsuccessful, there will be no reaction from the reader. If you can connect the VP6300 to a tablet or laptop and run the Universal SDK Demo program ("UDemo"), you can issue a CTLS (contactless) Start Transaction command and see results come back in the log pane of the demo UI.

4. Installation Points

- The VP6300 is designed to be mounted on a metal surface and in reasonably close proximity to any internal motors and electrical devices that may be operating inside the host machine. However, the unit (like all NFC/RFID devices) is susceptible to RF and electromagnetic interference. ***It is important that the unit not be mounted near (within 3 or 4 feet) large electric motors, computer UPS systems, microwave transmitters, anti-theft devices, radio transmitters, routers, and so on.***
- Close proximity of large metal objects to the RF-emitting end of the NFC antenna can greatly reduce the range of the antenna.
- Tie all cables neatly with nylon cable-ties and route them so that they are inaccessible and invisible to customers. Label the cable ends as "host," "ViVOpay" and "power," to simplify connection testing or component replacement, particularly when untrained individuals might be involved.
- Test the installation using a test card to perform an end-to-end transaction. The front bezel's lights should illuminate. Even if the transaction is declined (as it should be with a test card), it will prove connectivity all the way through the system. If possible, the store manager or some other responsible party should test each VP6300 on a regular basis (perhaps at the start of

each day or at least once per week) with a test card, to ensure proper operation and correct functionality. If the unit is rebooted on a regular basis (such as every night) it is important to test the contactless reader portion as soon as possible thereafter, to ensure continued communication.

5. RF Interference

Q. Why do I need to know about RF interference?

A. Contactless payment devices use radio frequency technology to send card data to a contactless terminal reader.

Q. How can RF interference affect contactless payment?

A. Radio frequency interference can cause data errors. If RF interference is present, contactless payment devices may operate intermittently or inconsistently.

Q. Where does RF interference come from?

A. Radio frequency interference (RFI) can originate from a wide number of sources at the point-of-sale (POS). Some examples of sources of RF energy and RF interference include:

- AM/FM radio and TV transmitters
- 2-way radios, pagers
- Mobile telephones
- Power lines, transformers
- Large electric motors
- Medical equipment
- Microwaves
- Electromechanical switches
- Wireless Routers

Q. What should I do if I suspect RF interference exists in my environment?

A. Begin by inspecting your environment for possible sources of RF interference.

Q. Do equipment manufacturers test their devices for RF interference?

A. Yes. Electronic equipment is tested for RFI sensitivity by the manufacturers. These tests are performed in a controlled laboratory environment and will often not replicate the types of situations that would be encountered in your own point-of-sale (POS) environment.

Q. What RF levels will impact RF operations?

A. Factors that can cause RF interference vary case-by-case. There are no set rules defining a single RF level that will cause RFI. RFI depends on the sensitivity of the equipment under consideration, or how low an interpreting signal can be in the presence of the equipment and cause problems.

Equipment can be particularly sensitive to very low signal levels of one frequency and yet be quite immune to high signal levels of another frequency -- so frequency is an important factor. Some electronic system components are internally shielded and have a very high immunity to interference; but generally, most equipment has not been so engineered.

6. Firmware Upgrade

The VP6300 can have its firmware upgraded in the field using either serial or USB interfaces.

Preparation

To update the new firmware you will need:

- PC with available serial or USB port
- VP6300 with a serial data cable or a USB cable attached
- Firmware files (including Boot Loader files) for the desired firmware
- Software (for the PC) that will upload the firmware files to the VP6300

6.2 Uploading Firmware for RS232 or USB

1. Move firmware files (*.fm) and bootloader .exe files into into the same folder.
2. Check and confirm device is correctly connected to the power source and RS-232/USB connection.
3. If RS232 is the interface choice, then please close all software that is using RS-232 communication.
4. Run the bootloader utility, choosing communication type and parameters according to the connection interface.
 - For serial interface, choose “COM” and Baud Rate of 19200 (default).
 - For USB interface, choose “HID” and verify VID displaying 0ACD.
5. Click the “Load” button - the firmware will be loaded into the device. When “Firmware successfully downloaded” appears on the utility, then the firmware has been successfully installed. The Utility may be closed at that time.

Serial Interface:

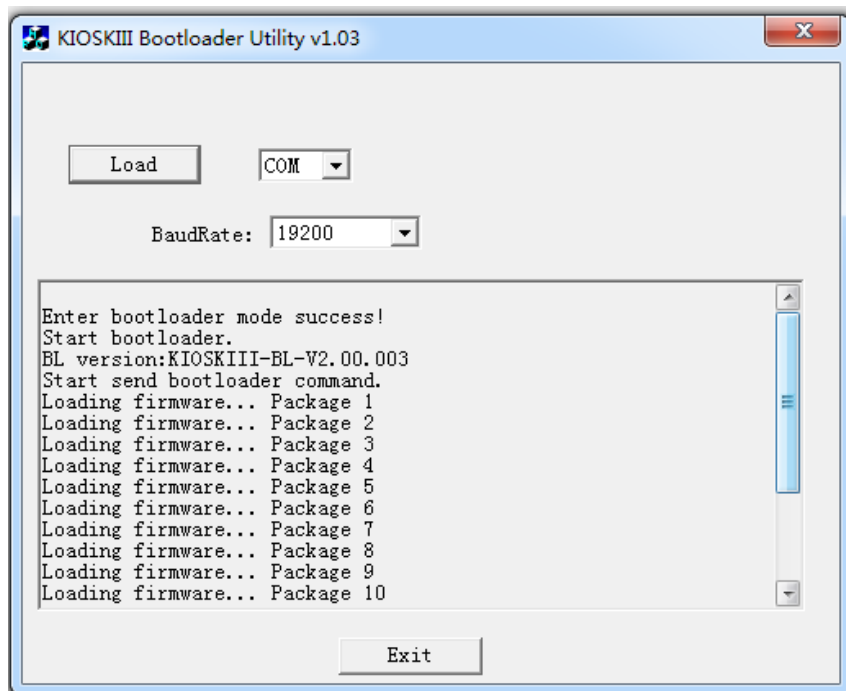

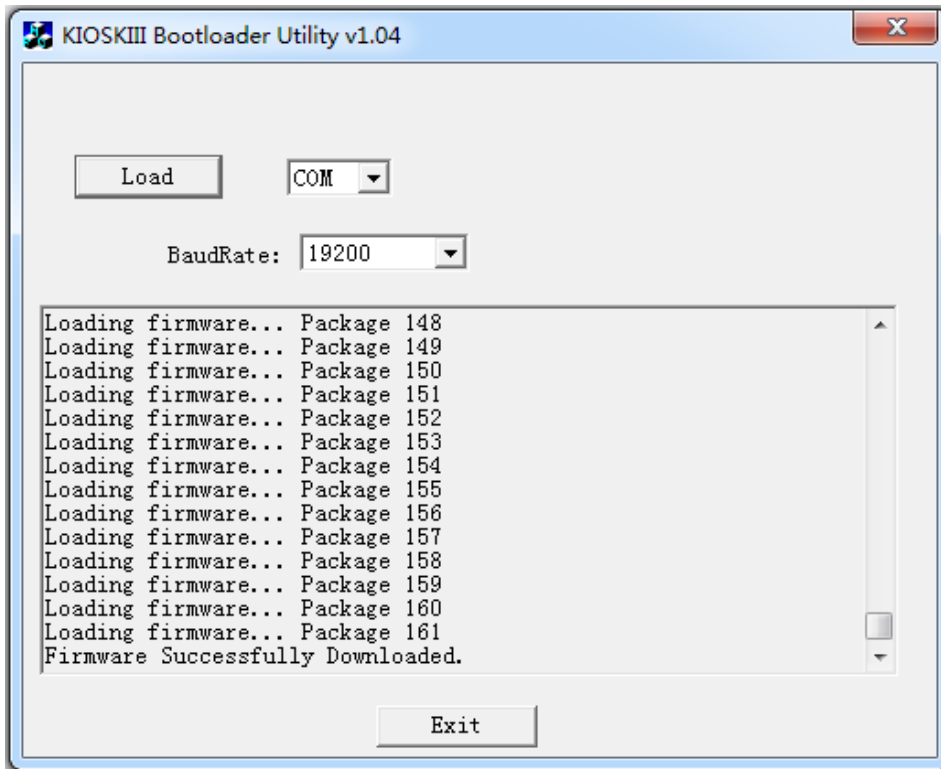

USB interface:

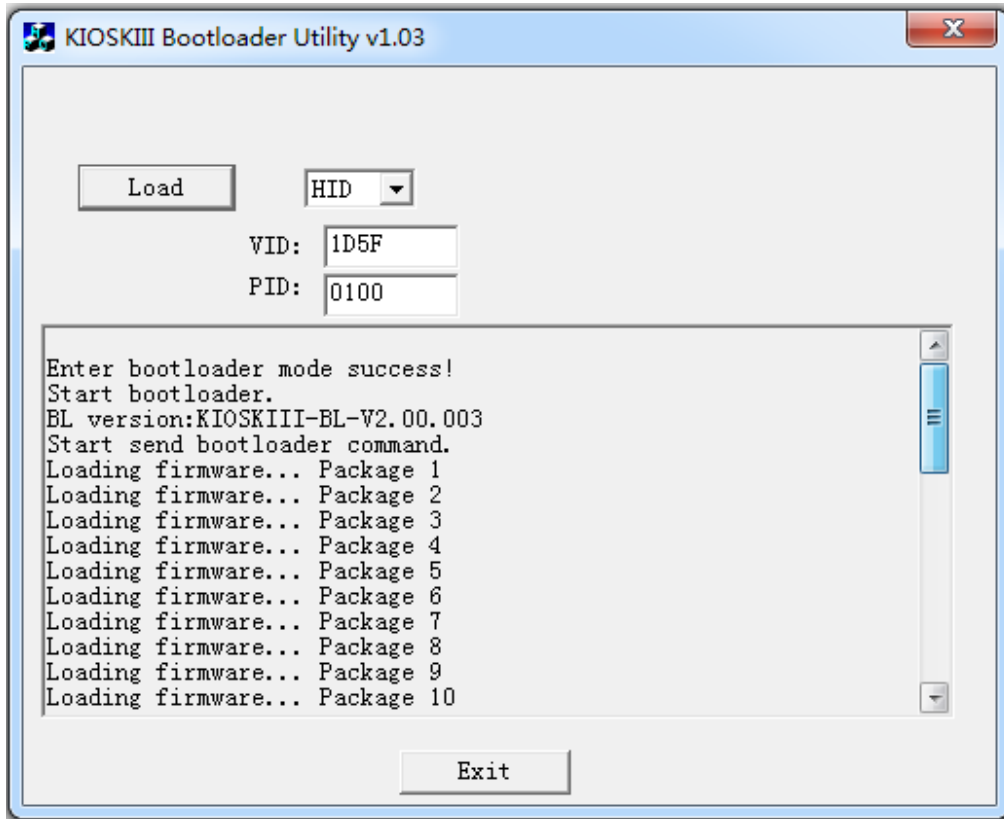

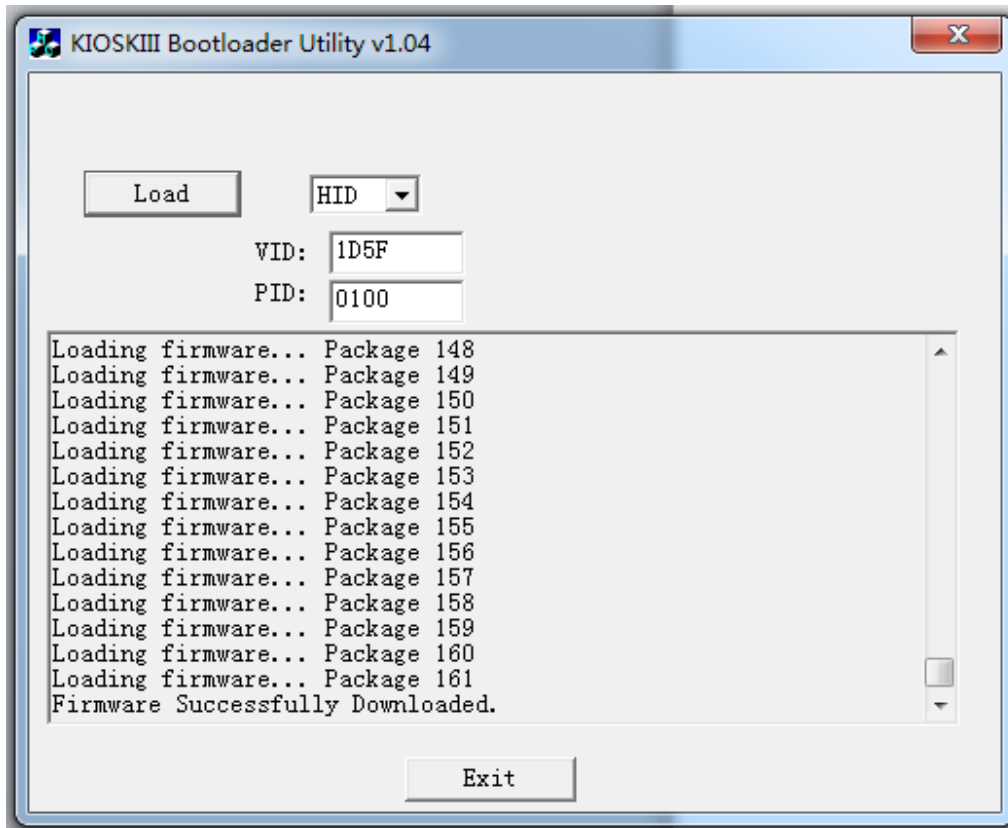

7. Troubleshooting

The ViVOPay VP6300 reader is designed to be reliable and easy to troubleshoot. The components that may require troubleshooting include the power module (if applicable), the reader, and the serial cable.

Symptom	Possible Cause	Remedy
General Issues		
Reader does not appear to be powered on (no LEDs are lit).	<ul style="list-style-type: none"> • Reader not powered on or incorrect voltage. • Improper use of internal power supply provided by the kiosk. 	<ul style="list-style-type: none"> • Check cable connections. • Verify that power is on and correct voltage and current are present. • Make sure that the correct pins are utilized. • Make sure that the power provided is within the specified range of the reader. • Make sure that the correct polarity is observed. • For more information, refer to the Input Voltage under the Electrical specification section.

Symptom	Possible Cause	Remedy
		<ul style="list-style-type: none"> • Replace the device with a known-good device to verify that the power supply and wiring in the installation are sound.
Reading Cards/Phones		
<p>LEDs do not light and beeper is not audible when card/fob presented.</p>	<ul style="list-style-type: none"> • Card/fob/phone not properly presented. • RF interference. • Unsupported card used. • Wrong firmware (contact your local support representative). 	<ul style="list-style-type: none"> • Present card/fob/phone closer to the antenna, and ensure it is parallel to the face of the reader. • Verify that the card/fob/phone is valid/current. • Verify that metal is not interfering with the antenna. • Test with “ViVOCARD Contactless Test Card” part number 241-0015-03 Rev A. • Try a different card/fob. • Check to see if card/fob is damaged. • Verify that correct firmware is loaded on reader (local support representative only). • Power cable plug is fully inserted. • Replace the unit.

Some cards/fobs read, but not all.	<ul style="list-style-type: none"> • Possible bad card/fob. • Unsupported card used. • Wrong firmware (contact your local support representative). 	<ul style="list-style-type: none"> • Check to see if card/fob is damaged. • Verify that correct firmware is loaded on reader (local support representative only). • Card readers must contain the latest versions of card-brand public certificates (CAPKs). If a CAPK is out of date, one particular kind of card may no longer be usable. Update the CAPK.
Communication to Kiosk		
No data is received, or data is garbled.	<ul style="list-style-type: none"> • Faulty or incorrect cable connections. 	<ul style="list-style-type: none"> • Check that the cable connection is secure and in the correct port on the unit.
Load Firmware		
Firmware loading software indicates "open RS-232 failed"	Device is not well connected to PC. Or other software is using the serial interface.	<ul style="list-style-type: none"> • Check the cable connection • Close other software which might be using the same serial interface.
Firmware loading software indicates "Load firmware failed."	Device is not well connected to PCs.	<ul style="list-style-type: none"> • Check the cable connections.
Firmware loading software indicates "Send Command failed."	Bootloader firmware in device is destroyed.	<ul style="list-style-type: none"> • Contact your support representative to reload manufacture's firmware.

If you are unable to resolve the problem, please contact support@idtechproducts.com (sending an e-mail to this address will automatically open a support ticket).

8. CFR 15.19 - Labeling requirements

15.19 Statement

This device complies with Part 15 of the FCC Rules.

Operation is subject to the following two conditions:

- 1) this device may not cause harmful interference and
- 2) this device must accept any interference received, including interference that may cause undesired operation of the device.