

# MorphoWave Compact

## Installation guide



DRAFT



---

# Warning

COPYRIGHT © 2018 Idemia. All rights reserved.

Reproduction in whole or in part in any form or medium without the express written permission of Idemia is prohibited. The trademarks identified herein are the trademarks of registered trademarks of Idemia, or other third party.

This legend is applicable to all pages of this document.

Information in this document is subject to change without notice and do not represent a commitment on the part of Idemia.

This manual makes reference to names and products that are trademarks of their respective owners.

DRAFT

---

# Revision history

Version	Date	Reference	Description
01	May 2018	2018_2000035853	Document creation

DRAFT

---

# Table of content

---

<b>1 / Introduction</b>	<b>8</b>
1.1 > MorphoWave Compact terminal	9
1.2 > Scope of the document	10
1.3 > Safety Instructions	11
1.4 > Wiring Recommendations	12
1.5 > Regulatory, safety and Environmental notices	13
1.5.1 > European Union (CE) regulatory notices	13
1.5.2 > USA (FCC) regulatory notices	14
1.5.3 > Canada (IC) regulatory notices	15
1.6 > Others recommendations	16
1.7 > Recommendations for terminal implementation	17
<b>2 / General description</b>	<b>20</b>
2.1 > Box opening	21
2.2 > Components of the initial package	22
2.3 > Terminal's front view description	23
2.4 > Terminal's rear view description	24
2.5 > MorphoWave Compact Technical Characteristics	25
<b>3 / Installation procedure</b>	<b>28</b>
3.1 > Before proceeding to the installation	29
3.2 > Installation	30
3.3 > Step by step procedure	31
3.3.1 > Drill the mounting holes	32
3.3.2 > Make the connections	33
3.3.3 > Attach the base plate on the wall	35
3.3.4 > Attach the device on the base plate	36
3.3.5 > Connect the connector assembly on the device	37
3.3.6 > Close the device on the base plate	38
<b>4 / Electrical interface</b>	<b>40</b>
4.1 > Wiring overview	41
4.2 > Power Supply	42

---

4.3 > Output Relay	44
4.4 > Tamper Switch	45
4.5 > Wiegand wiring	46
4.6 > Wiegand output	47
4.7 > Serial port wiring	49
4.8 > GPIO wiring	51
4.9 > Ethernet connection	52
4.10 > Internal USB connection	53
4.11 > Wi-Fi™ dongle installation	55
<hr/>	
<b>5 / User interface</b>	<b>57</b>
5.1 > Modes for controlling access rights	58
5.1.1 > Introduction	58
5.1.2 > Identification mode	58
5.1.3 > Authentication (verification) mode	58
5.1.4 > Multi-factor mode	58
5.1.5 > Proxy mode	59
5.1.6 > External database mode (also called polling mode)	59
5.1.7 > MorphoWave Compact native mode	61
5.1.8 > Anti-tamper / anti-pulling switches	62
<hr/>	
<b>6 / Accessories, Software Licenses and PC Applications</b>	<b>63</b>
6.1 > Compatible Accessories, Licenses and Software	64
6.2 > Compatible PC applications	65
<hr/>	
<b>7 / Recommendations</b>	<b>66</b>
<hr/>	
<b>8 / Annex 1 : finger placement recommendations</b>	<b>69</b>
8.1 > Main principles	70
8.2 > Capture recommendations	71
Proper Use	71
Improper Use	72
<hr/>	
<b>9 / Annex 2 : Bibliography</b>	<b>74</b>
9.1 > How to get the latest versions of documents	75
9.2 > Documents about the MorphoWave Compact terminal	76
<hr/>	
<b>10 / Annex 3 : Support</b>	<b>77</b>
10.1 > Troubleshooting	78
10.2 > Technical Support and Hotline	78

---

<b>1 / Introduction</b>	<b>9</b>
1.1 > MorphoWave Compact terminal	10
1.2 > Scope of the document	11
1.3 > Safety Instructions	12
1.4 > Wiring Recommendations	13
1.5 > Regulatory, safety and Environmental notices	14
1.5.1 > European Union (CE) regulatory notices	14
1.5.2 > USA (FCC) regulatory notices	15
1.5.3 > Canada (IC) regulatory notices	16
1.6 > Others recommendations	17
1.7 > Recommendations for terminal implementation	18

---

<b>2 / General description</b>	<b>21</b>
2.1 > Box opening	22
2.2 > Components of the initial package	23
2.3 > Terminal's front view description	24
2.4 > Terminal's rear view description	25
2.5 > MorphoWave Compact Technical Characteristics	26

---

<b>3 / Installation procedure</b>	<b>29</b>
3.1 > Before proceeding to the installation	30
3.2 > Installation	31
3.3 > Step by step procedure	32
3.3.1 > Drill the mounting holes	33
3.3.2 > Make the connections	34
3.3.3 > Attach the base plate on the wall	36
3.3.4 > Attach the device on the base plate	37
3.3.5 > Connect the connector assembly on the device	38
3.3.6 > Close the device on the base plate	39

---

<b>4 / Electrical interface</b>	<b>41</b>
4.1 > Wiring overview	42
4.2 > Power Supply	43
4.3 > Output Relay	45
4.4 > Tamper Switch	46
4.5 > Wiegand wiring	47
4.6 > Wiegand output	48

4.7 > Serial port wiring	50
4.8 > GPIO wiring	52
4.9 > Ethernet connection	53
4.10 > Internal USB connection	54
4.11 > Wi-Fi™ dongle installation	56

---

## **5 / User interface** **58**

5.1 > Modes for controlling access rights	59
5.1.1 > Introduction	59
5.1.2 > Identification mode	59
5.1.3 > Authentication (verification) mode	59
5.1.4 > Multi-factor mode	59
5.1.5 > Proxy mode	60
5.1.6 > External database mode (also called polling mode)	60
5.1.7 > MorphoWave Compact native mode	62
5.1.8 > Anti-tamper / anti-pulling switches	63

---

## **6 / Accessories, Software Licenses and PC Applications** **64**

6.1 > Compatible Accessories, Licenses and Software	65
6.2 > Compatible PC applications	66

---

## **7 / Recommendations** **67**

## **8 / Annex 1 : finger placement recommendations** **70**

8.1 > Main principles	71
8.2 > Capture recommendations	72
Proper Use	72
Improper Use	73

---

## **9 / Annex 2 : Bibliography** **75**

9.1 > How to get the latest versions of documents	76
9.2 > Documents about the MorphoWave Compact terminal	77

---

## **10 / Annex 3 : Support** **78**

10.1 > Troubleshooting	79
10.2 > Technical Support and Hotline	79



---

# 1 / Introduction

DRAFT

## 1.1 > MorphoWave Compact terminal

Congratulations for choosing MorphoWave Compact Automatic Fingerprint Recognition Terminal!

MorphoWave Compact provides an innovative and effective solution for access control applications using very fast acquisitions of four (4) fingerprints without any contact.

Among a range of alternative biometric technologies, the use of finger imaging has significant advantages: very fast acquisition from a single wave of the hand through the sensor, and no physical contact between the applicant and the glass.

Each finger constitutes an unalterable physical signature, developed before birth and preserved until death. Unlike DNA, a finger image is unique to each individual - even identical twins.

By “on-the-fly”, we mean:

- | Contactless acquisition: The user does NOT need to touch any part of the sensor
- | Acquisition in movement: Users swipe their hand across the sensor; no need to stop & position fingers. At the end of the swipe, the acquisition is complete.

MorphoWave Compact integrates Idemia image processing and feature matching algorithms. This technology is based on lessons learned during 25 years of experience in the field of biometric identification and the creation of literally millions of individual fingerprint identification records.

We believe you will find the MorphoWave Compact fast, accurate, easy to use and suitable for physical access control.

The MorphoWave Compact offers the following advantages:

- | high quality optical sensor with false finger detection option,
- | supports multiple input/output interfaces used in the physical access control industry,
- | Local Area Network interface for easy interaction with other host systems ; LAN and WLAN possibilities (Wi-Fi™ as an option),
- | intuitive man machine interface with touch panel and display, that is easy to use in both setup and operational modes,
- | sturdy wall mounting with easy holding of product during cabling or maintenance,

To ensure the most effective use of your MorphoWave Compact terminal, we recommend that you read this Installation Guide completely.

## 1.2 > Scope of the document

This guide deals with the installation of MorphoWave Compact, which is made up of the following list of products:

MorphoWave Compact Marketing Name	Biometrics	Fake Finger Detection	Contactless smartcard reader			Water Resistant	Regulatory Model Number (*)
			iCLASS®	MIFARE® DESFire® NFC	Prox®		
MorphoWave Compact MD	✓	✓		✓		✓	MPH-AC004A
MorphoWave Compact MDPI	✓	✓	✓	✓	✓	✓	MPH-AC004B

(\*) The Regulatory Model Number is the main product identifier in the regulatory documentation and test reports associated to the product

DRAFT

## 1.3 > Safety Instructions

 means Direct Current (DC)

The installation of this product should be made by a qualified service Person and should comply with all local regulations.

It is strongly recommended to use a class II power supply at 12V-24V and 2.5 A. min (at 12V) in conformity with Safety Electrical Low Voltage (SELV). The power supply cable length should not exceed 10 meters.

This system must be installed in accordance with the National Electrical Code (NFPA 70), and the local authority having jurisdiction.

This product is intended to be installed with a power supply complying with IEC60950-1, in accordance with the NEC Class 2 requirements; or supplied by a listed IEC60950-1 external Power Unit marked Class 2, Limited Power source, or LPS and rated 12VDC, 2.5 A minimum or 24VDC, 1.25 A minimum.

In case of building-to-building connection it is recommended to connect 0V to ground. Ground cable must be connected with the terminal block Power Ground.

Note that all connections of the MorphoWave Compact terminal described hereafter are of SELV (Safety Electrical Low Voltage) type.

DRAFT

## 1.4 > Wiring Recommendations

Idemia recommends using a AWG16 gauge and 24V power supply when PoE+ supply is not used.

The voltage specified is the one measured on the product block connector: 12V-24V (-15% / +10%).

The voltage drop due to the cable shall be taken into account. The following table shows the maximum distance between power supply and one (1) unique device, depending on cable gauge and power supply rating:

Gauge AWG	Section (mm <sup>2</sup> )	Maximum distance (meters) vs power source rating		
		12V+/-10%	12V+/-5%	24V+/-10%
<b>16</b>	1.31	9 m	20 m	300 m
<b>18</b>	0.82	6 m	12 m	200 m
<b>20</b>	0.52	3 m	8 m	120 m
<b>22</b>	0.32	2 m	5 m	75 m

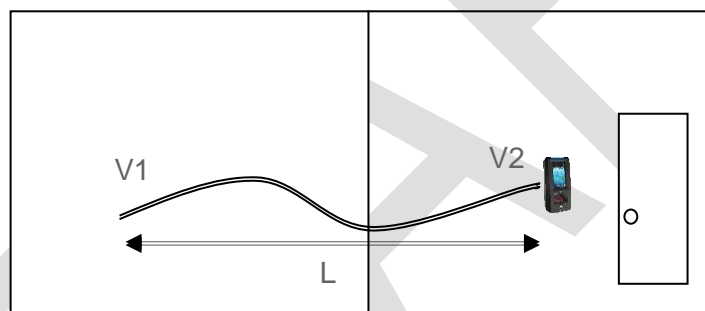

Drop voltage = loss of power due to wire resistance and its length:  $V2 = V1 - \text{Drop voltage}$

## 1.5 > Regulatory, safety and Environmental notices

### 1.5.1 > European Union (CE) regulatory notices

#### ***Declaration of Conformity***



Products bearing the CE marking comply with one or more of the following EU Directives as may be applicable:

- | Low Voltage Directive 2006/95/EC
- | EMC Directive 2004/108/EC
- | R&TTE Directive 1999/5/EC
- | Ecodesign Directive 2009/125/EC
- | RoHS Directive 2011/65/EU.

Compliance with these directives is assessed using applicable European Harmonised Standards.

MorphoWave Compact terminals are intended to be used for professional application only (buildings, airport...).

This is an EMC Class A product according to EMC directive 2004/108/EC. This product may cause interference if used in residential areas. Such use must be avoided unless the user takes special measures to reduce magnetic emissions to prevent interference to the reception of radio and television broadcast.

The full Declaration of Conformity is available on demand to your reseller. Please, provide him the product model name or its Regulatory Model Number (Model on the label).

#### ***Products with wireless features (EMF)***

This product meets the provisions of the EU's Council recommendation 1999/519/EC on the limitation of the exposure of the general public to electromagnetic fields (0 Hz to 300 GHz).

## 1.5.2 > USA (FCC) regulatory notices



*This device complies with part 15 of the FCC Rules. Operation is subject to the following two conditions: (1) this device may not cause harmful interference, and (2) this device must accept any interference received, including interference that may cause undesired operation.*

*This device complies with FCC RF radiation exposure limits set forth for general population. This device must be installed to provide a separation distance of at least 20cm from all persons and must not be co-located or operating in conjunction with any other antenna or transmitter*

Changes or modifications not expressly approved by the party responsible for compliance could void the user's authority to operate the equipment.

Responsible Party:

**Idemia**  
**11, boulevard Gallieni**  
**92130 Issy-les-Moulineaux – France**

**NOTA :** *This equipment has been tested and found to comply with the limits for a Class B digital device, pursuant to Part 15 of the FCC Rules. These limits are designed to provide reasonable protection against harmful interference in a residential installation. This equipment generates, uses and can radiate radio frequency energy and, if not installed and used in accordance with the instructions, may cause harmful interference to radio communications. However, there is no guarantee that interference will not occur in a particular installation. If this equipment does cause harmful interference to radio or television reception, which can be determined by turning the equipment off and on, the user is encouraged to try to correct the interference by one of the following measures:*

- | Reorient or relocate the receiving antenna.
- | Increase the separation between the equipment and receiver.
- | Connect the equipment into an outlet on a circuit different from that to which the receiver is connected.
- | Consult the dealer or an experienced radio/TV technician for help.

Shielded cables must be used with this unit to ensure compliance with category B FCC restrictions.

- | MPH-AC004B product model includes a module tested under the FCC rules for a Modular Approval.
  - o FCCID: JQ6-SE3210

### 1.5.3 > Canada (IC) regulatory notices

#### *WARNING TO USERS IN THE CANADA / ATTENTION POUR LES UTILISATEURS AU CANADA*

This device complies with Industry Canada license-exempt RSS standard(s). Operation is subject to the following two conditions: (1) this device may not cause interference, and (2) this device must accept any interference, including interference that may cause undesired operation of the device.

Under Industry Canada regulations, this radio transmitter may only operate using an antenna of a type and maximum (or lesser) gain approved for the transmitter by Industry Canada.

To reduce potential radio interference to other users, the antenna type and its gain should be so chosen that the equivalent isotropically radiated power (e.i.r.p.) is not more than that necessary for successful communication.

This device complies with Industry Canada RF radiation exposure limits set forth for general population. This device must be installed to provide a separation distance of at least 20cm from all persons and must not be co-located or operating in conjunction with any other antenna or transmitter.

Note: UL LLC has not verified this product for compliance in respect to Canadian standards.

- | MPH-AC004B product model includes a module compliant with limits set by Industry Canada
  - IC: 2236B-SE3210

Le présent appareil est conforme aux CNR d'Industrie Canada applicables aux appareils radio exempts de licence. L'exploitation est autorisée aux deux conditions suivantes:

- 1) l'appareil ne doit pas produire de brouillage, et
- 2) l'utilisateur de l'appareil doit accepter tout brouillage radioélectrique subi, même si le brouillage est susceptible d'en compromettre le fonctionnement.

Conformément à la réglementation d'Industrie Canada, le présent émetteur radio peut fonctionner avec une antenne d'un type et d'un gain maximal (ou inférieur) approuvé pour l'émetteur par Industrie Canada. Dans le but de réduire les risques de brouillage radioélectrique à l'intention des autres utilisateurs, il faut choisir le type d'antenne et son gain de sorte que la puissance isotrope rayonnée équivalente (p.i.r.e.) ne dépasse pas l'intensité nécessaire à l'établissement d'une communication satisfaisante.

Le présent appareil est conforme aux niveaux limites d'exigences d'exposition RF aux personnes définies par Industrie Canada. L'appareil doit être installé afin d'offrir une distance de séparation d'au moins 20cm avec l'utilisateur, et ne doit pas être installé à proximité ou être utilisé en conjonction avec une autre antenne ou un autre émetteur.

- | Le modèle de produit MPH-AC004B intègre un module conforme aux limites d'exigences définies par Industrie Canada.
  - IC: JQ6-SE3210



## 1.6 > Others recommendations

### ***Potential safety conditions notice***

If you notice any of the following conditions (or if you have other safety concerns), do not use the product: crackling, hissing, or popping sound, or a strong odor or smoke coming from the product. It is normal for these conditions to appear when an internal electronic component fails in a safe and controlled manner. However, these conditions may also indicate a potential safety issue. Do not assume it is a safe failure. Turn off the product, disconnect it from its power source, and contact technical support for assistance.

### ***Disposal of waste equipment by users***



This symbol means do not dispose of your product with your other household waste. Instead, you should protect human health and the environment by handing over your waste equipment to a designated collection point for the recycling of waste electrical and electronic equipment.

## 1.7 > Recommendations for terminal implementation

Every installation is unique. Sometimes the issues are well defined and can be handled in a standard fashion; sometimes the issues are very specific and may not be immediately recognizable.

Idemia recommends following these steps for a successful installation:

- | **Plan the installation** - Choose the type of hardware required, decide if a network is required, and decide on the location and number of required terminals.
- | **Unpack all items** - Unpack all items and check against the packing list.
- | **Install network hardware components** - Install the cabling and components needed to run the system.
- | **Install software** - Install the software needed to set up the terminals.
- | **Pre-configure device** - Connect the terminals to the Ethernet, supply power to the terminals, and pre-configure the terminals.
- | **Mount devices** - Mount the terminals in their final locations
- | **Power distribution and device hook up** - Connect the terminals wiring via the back panel.
- | **Power-up procedure** - Check the power connections, and then start the system safely. First Boot Assistant screen is displayed, where you can perform **fundamental** configuration.

To secure properly an access, Idemia recommends installing the MorphoWave Compact terminal as a part of the typical Access Control environment described in the figure below.

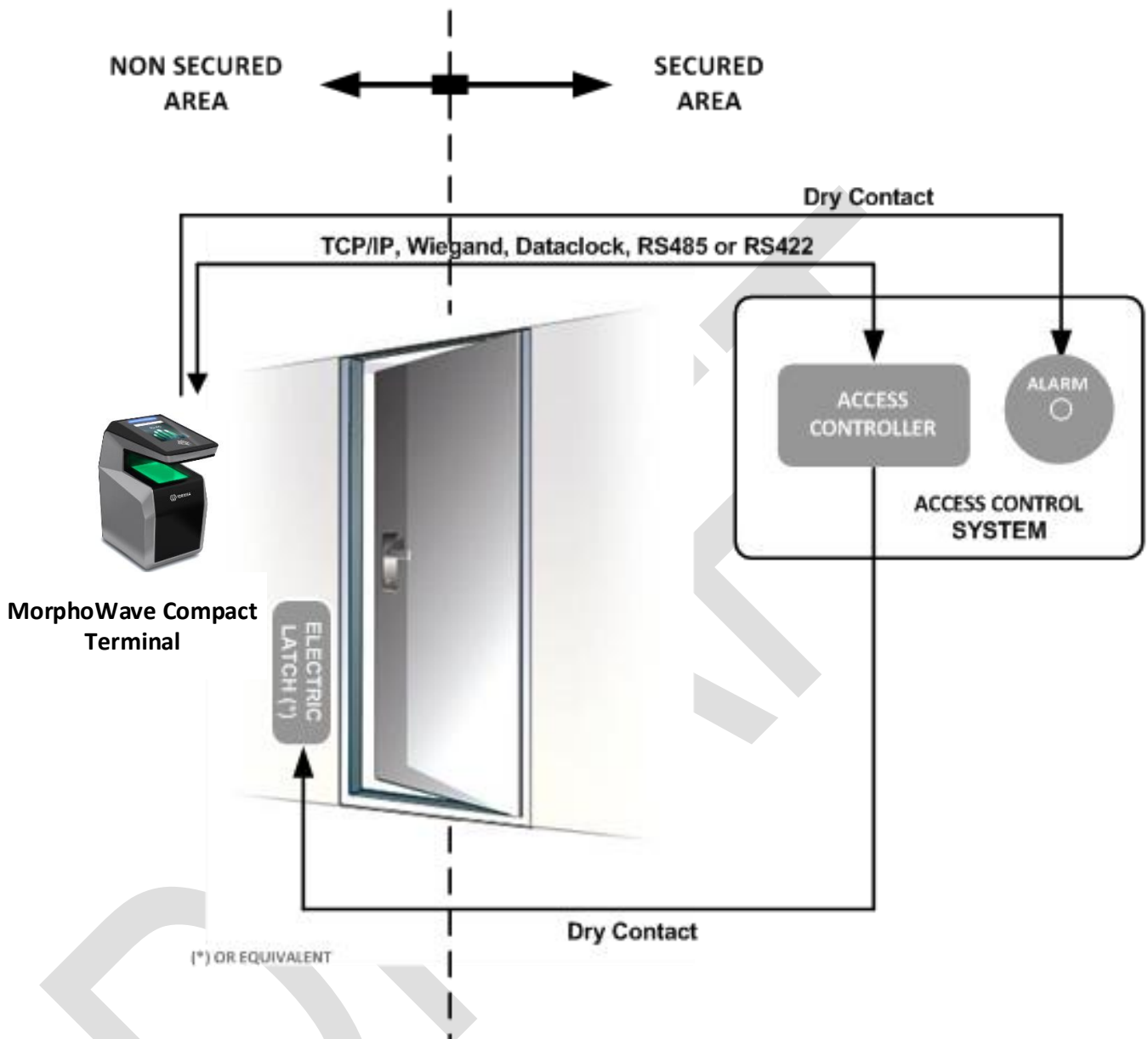

**Figure: Implementation Recommendations**

This environment comprises:

*The MorphoWave Compact terminal itself*

Its role is to perform one-to-many biometric identification or one-to-one biometric verification, i.e. to identify the individual who is presenting his finger on the terminal sensor by comparing his biometric data with the references previously stored in the terminal database (in the form of biometric templates) or to verify his identity using the reference stored in a contactless card presented to the terminal.

*An Access Controller (3rd party product)*

The Controller is the element which controls the access rights of the individuals to the secured area. For that reason, it must be located in the secured area.

The individuals who are authorized to access the secured area have their User ID listed in a so-called "Authorized User List" (in contrast with a banned card list).

The MorphoWave Compact terminal and the Controller are communicating according to one of the TCP/IP, Wiegand, Dataclock or RS485 protocols:

- | The MorphoWave Compact terminal sends User ID to the Controller
- | The Controller sends its decision to the MorphoWave Compact terminal (which displays access granted or access denied depending on the answer)
- | The MorphoWave Compact terminal sends an alarm signal to the Controller as soon as a malicious operation is detected (terminal pulled out from the wall or opened for maintenance operations); refer the paragraph dealing with anti-pulling and anti-tamper switches for more explanations.

The Controller is part of the global Access Control System of the secured area, which can provide useful features such as manage:

- | authorized user lists (i.e. for VIP),
- | banned card lists (i.e. for lost user cards),
- | an access request log (who and when, access granted or denied,..),
- | an event log (i.e. tamper detection, access control for evacuation of the building,...).

The MorphoWave Compact terminal is able to work alone, without Controller, but the protection level of the secured area is lower.

#### ***An Alarm (3rd party product)***

This element is connected to the MorphoWave Compact terminal through a dry contact.

The MorphoWave Compact terminal sends the command to activate the Alarm as soon as a malicious operation (terminal pulled out from the wall or having its bottom cover opened out of maintenance operations) is detected; refer the paragraph dealing with anti-pulling and anti-tamper switches for more explanations.

#### ***A Door Electric Latch or equivalent (3rd party product)***

This element once activated opens the access. The Controller is the one which sends the command to activate the latch if access is granted (i.e. if the individual's User ID is listed in the Controller Authorized User List). Connection between these two elements is done through a dry contact.

---

## 2 / General description

DRAFT

## 2.1 > Box opening

At the box opening, components shall be extracted from the protection casing as depicted in the pictures below.

Extract the wall plate (which is not screwed to the terminal) and keep it separate until the installation of the terminal is completed. The screwing of the product to the wall plate is the last stage of the installation.

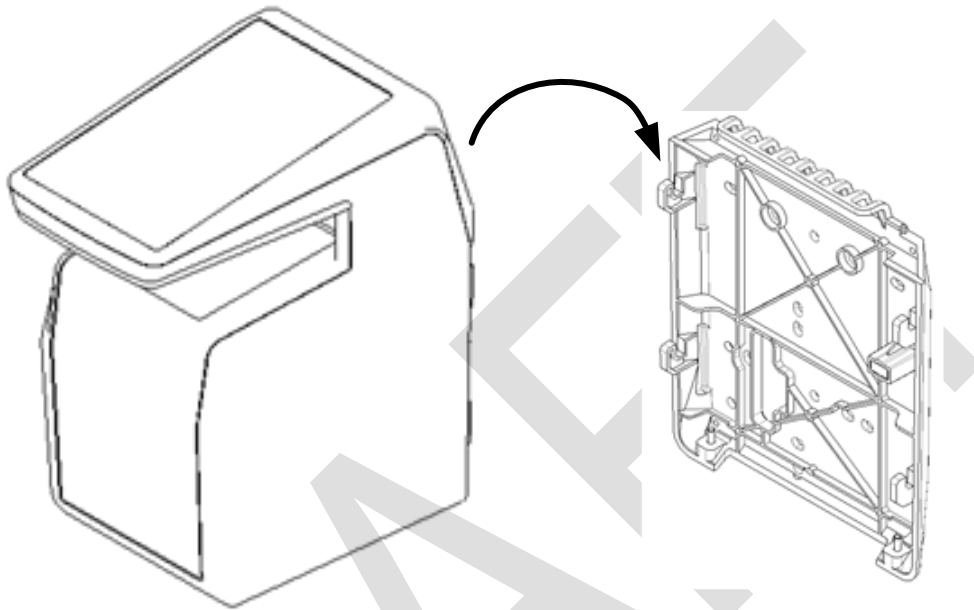

**Figure 1: Box Opening**

## 2.2 > Components of the initial package

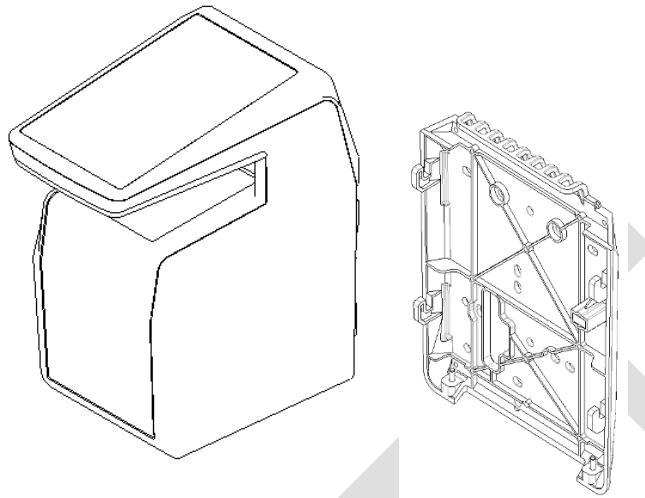

**Figure 2: Box Content**

1. One (1) Terminal's body
2. One (1) Wall frame

## 2.3 > Terminal's front view description



Figure 3: MorphoWave Compact terminal front view



## 2.4 > Terminal's rear view description

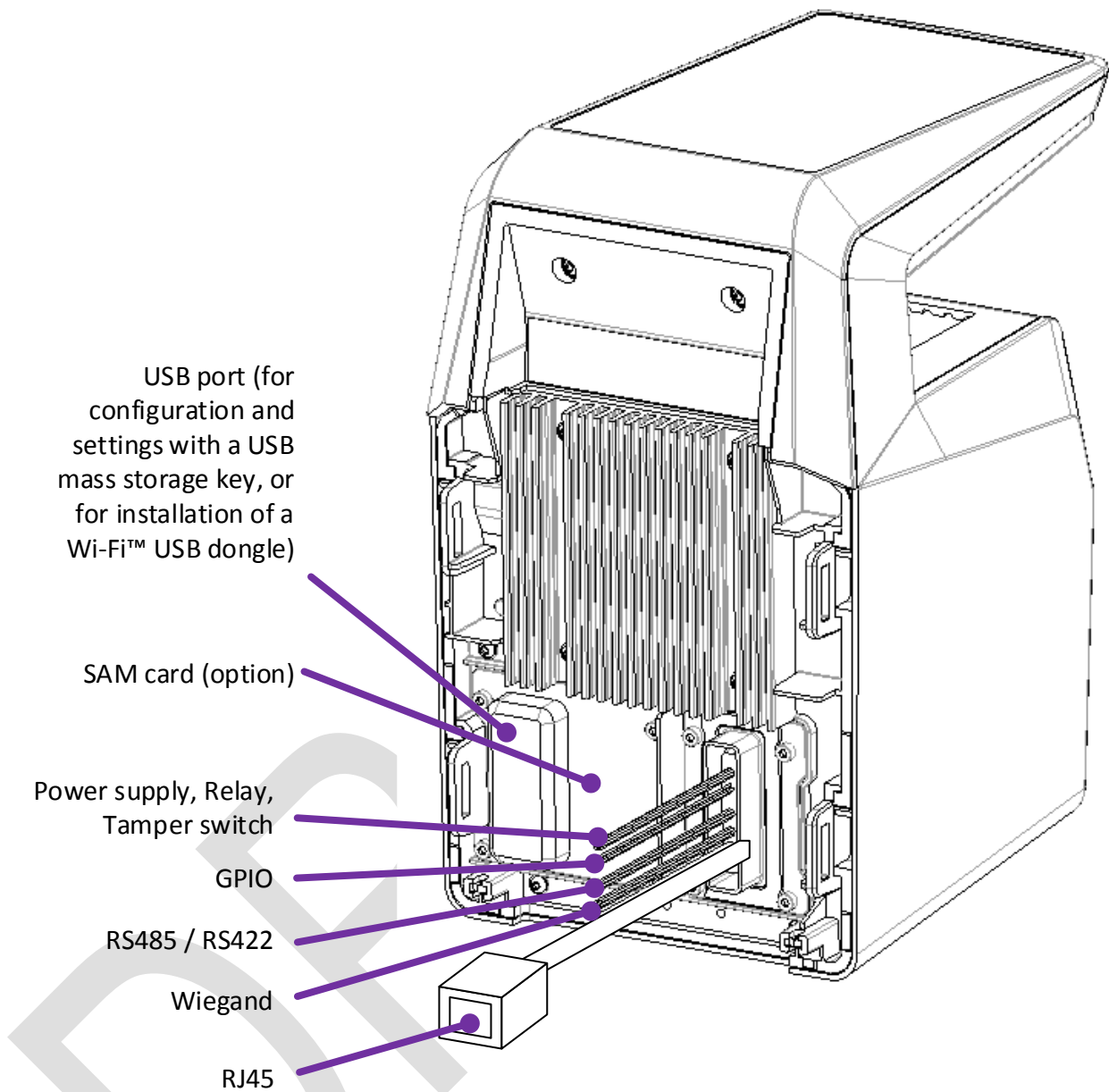

**Figure 4: MorphoWave Compact terminal rear view**

## 2.5 > MorphoWave Compact Technical Characteristics

Item	Description
Access control modes	Identification (search for fingerprints in a local database)
	Authentication with contactless smartcard, with or without fingerprint check
	Multi-factor: identification or authentication (only if terminal is equipped with a contactless smartcard reader)
	Proxy: the access control check is fully driven by a remote system
Man Machine Interface	4.3" WVGA color capacitive Touchscreen
	Powerful Loudspeaker & Microphone
Biometrics	Hand swipe through the active volume without contact: 40 x 25 x 80 mm (WxHxD) capture volume (1.57" x 0.98" x 3.14") 500dpi, 256 gray levels optical sensor 0.5 m/s (19.7 in/s) maximum hand speed Up to 4 fingers capture capacity per swipe motion
	False Acceptance Rate (FAR) adjustable from 1% down to 10 <sup>-7</sup> %
	Database capacity: 20,000 users (standard) and up to 100 000 users (with specific license)
Log capacity	1 000 000
LAN/WLAN connection	For terminal configuration and data transfer: Ethernet 10/100 Base T (MDI, MDI-X) Or Wi-Fi™ Wireless LAN (option), WEP, WPA (PSK) and WPA2 (PSK) encryption available Either TCP, SSL or TLS protocol
	MIFARE Classic 1KB & 4KB (4b and 7b UID)

RFID cards (depending on product version)	MIFARE Plus SL1 cards
	DESFire 3DES legacy 2K, 4K and 8K (EV0 & EV1) DESFire AES 2k, 4k, 8k (EV1)
	All HID iClass cards (incl. iClass legacy, iClass SR and iClass SE), except 2K2
	HID Prox 125 kHz whatever the format (26, 37 ....)
Serial port	The serial port supports WIEGAND, DATACLOCK (ISO2), RS422 and RS485 protocols
GPIO	3 GPI, 3 GPO
Output relay switches	Access granted: 1 switch two outputs (normally “open” and normally “closed”) 30V – 1A max (Resistive loads, 100 000 cycles)
USB host port	terminal configuration through a USB mass storage key connection with an external Wi-Fi™ USB dongle using an adapter cable
Input signals	LED1/LED2 to activate the access granted relay
Power supply	12 to 24 V DC power supply (2.5A min @12V) Or by Power Over Ethernet through RJ-45 connector Note for UL 294 Compliance power supply shall be UL 294 and UL 294B with power limited output
Security of the terminal	Anti-tamper-pulling switches Tamper-pulling detection: one switch closed when product wall mounted, open when pulled out
Size and weight	W x H x D: 152 mm x 250 mm x 220 mm (6.98” x 9.84” x 8.66”) Weight : ~ 2 kg
Environmental conditions	Operating temperature: -10 °C to + 55 °C (14°F to 131°F) when ECO-mode is ON

	-10 °C to + 45 °C (14°F to 113°F) when ECO-mode is OFF
	Operating humidity 10 % < RH < 80 % (non condensing)
	Storage temperature -25 °C to + 70 °C (-13°F to 158°F)
	Storage humidity 5% < RH < 95 %
	The terminal should be installed in controlled lighting conditions Avoid direct exposure to sunlight or to UV lights
Certification planned	CE, IEC 60950-1, FCC Part 15, RSS210 - Issue 8 : 2010, RSS-102 - Issue 5 : 2015, RSS-Gen – Issue : 2014, RoHS, REACH, WEEE

DRAFT

---

## 3 / Installation procedure

DRAFT

### 3.1 > Before proceeding to the installation

- | Make sure that you have all the components described in “Components of the initial package” section at your disposal.
- | Remove the wall plate. Keep this element at hand.

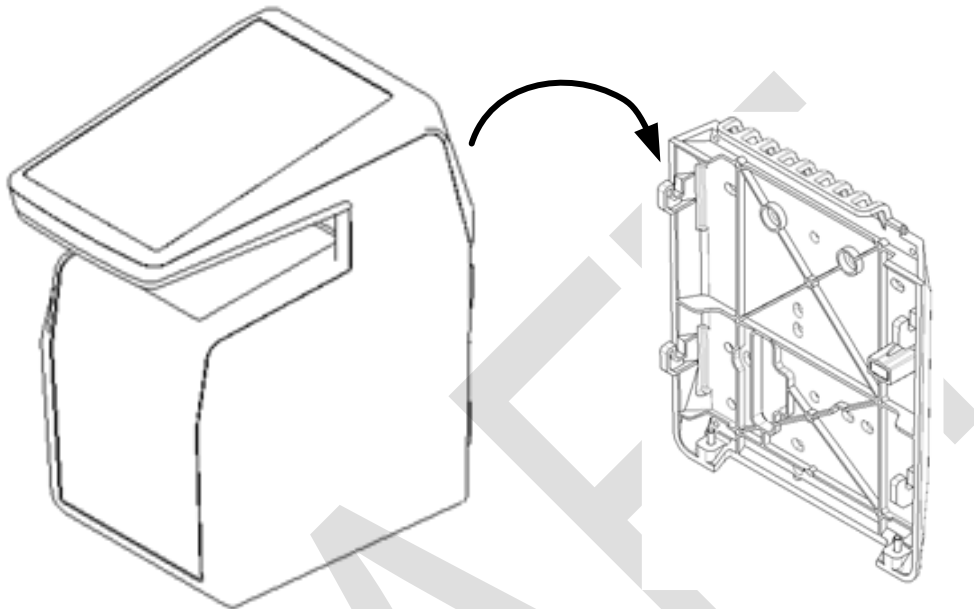

**Figure 5: Removing wall frame**

It is then possible to fix the terminal on the wall.



*For an optimal use the terminal must be installed in an area where the lighting conditions are controlled. Avoid direct exposure of the sensor to the sun light and ensure good ambient lighting for face detection if used.*

## 3.2 > Installation

### *Required tools (not supplied)*

- | Four (4) raw plugs + four (4) screws  $\varnothing$ 4mm max and length adapted to the wall material.
- | One (1) screwdriver adapted to screws above.
- | One (1) Drill (with a drill bit diameter adapted to raw plugs above).
- | One (1) hole saw (depending on installation case).
- | A (1) CHC H2 screwdriver
- | A (1) CHC H2.5 screwdriver
  
- | Deadbolt/door strike
- | Snubber diode required to protect regulated DC power supply from inductive kickback (1N4007 diode or equivalent recommended)
- | Separate power supply for the deadbolt/door strike based on supplier's recommendations.
- | External relay (if required)
- | Networking cable

For UL-294 compliance, an earthed screen in the wire or around all wires to/from product is only required when the wires share space/compartments/tube with high voltage cables.

### *Equipment from the initial package to use*

- | One (1) Terminal's body.
- | One (1) wall plate.

### 3.3 > Step by step procedure

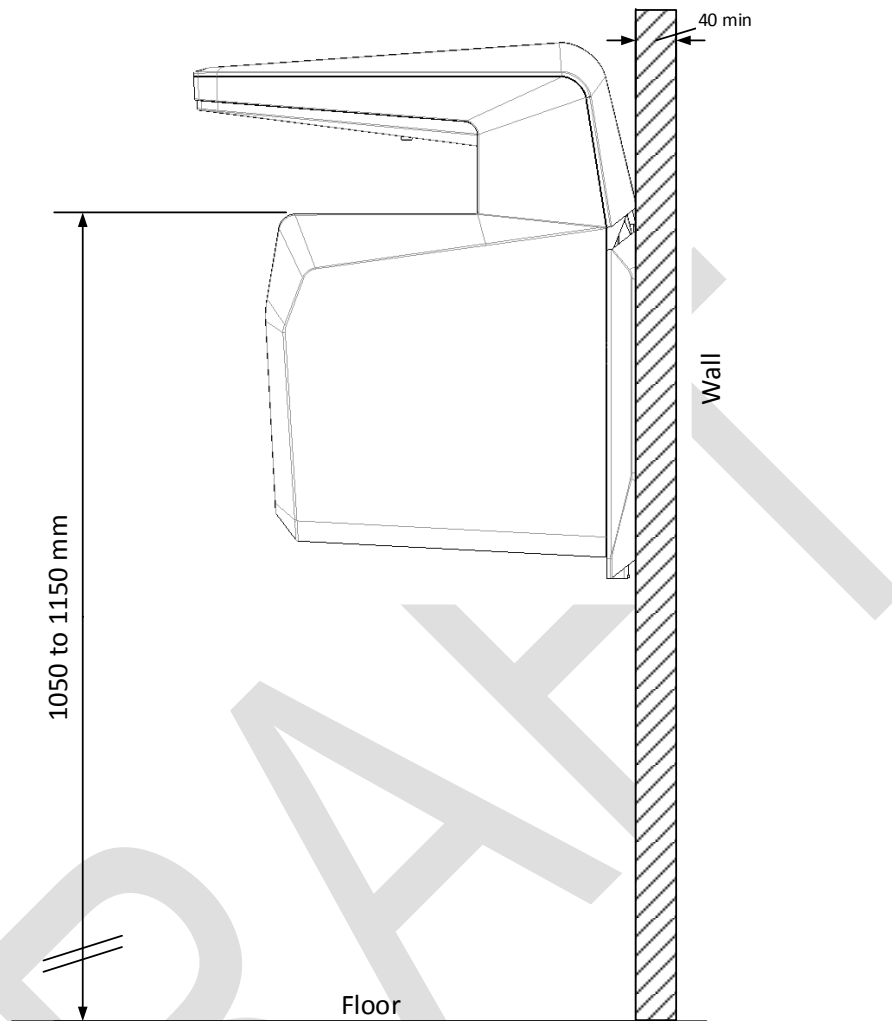

Figure 6: Face camera viewing angle

The recommended height for fixing of the terminal is 1.05 to 1.15 m (height of the acquisition glass).



*For an optimal use the terminal must be installed in an area where the lighting conditions are controlled. Avoid direct exposure of the sensor to the sun light.*



*Power supply from electrical source shall be switched off before starting the installation.*



*The strength of the attachment depends on the solidity of the wall on which the terminal is mounted.*



### 3.3.1 > Drill the mounting holes



*Be sure that the wall behind the wall plate has a good flatness.*

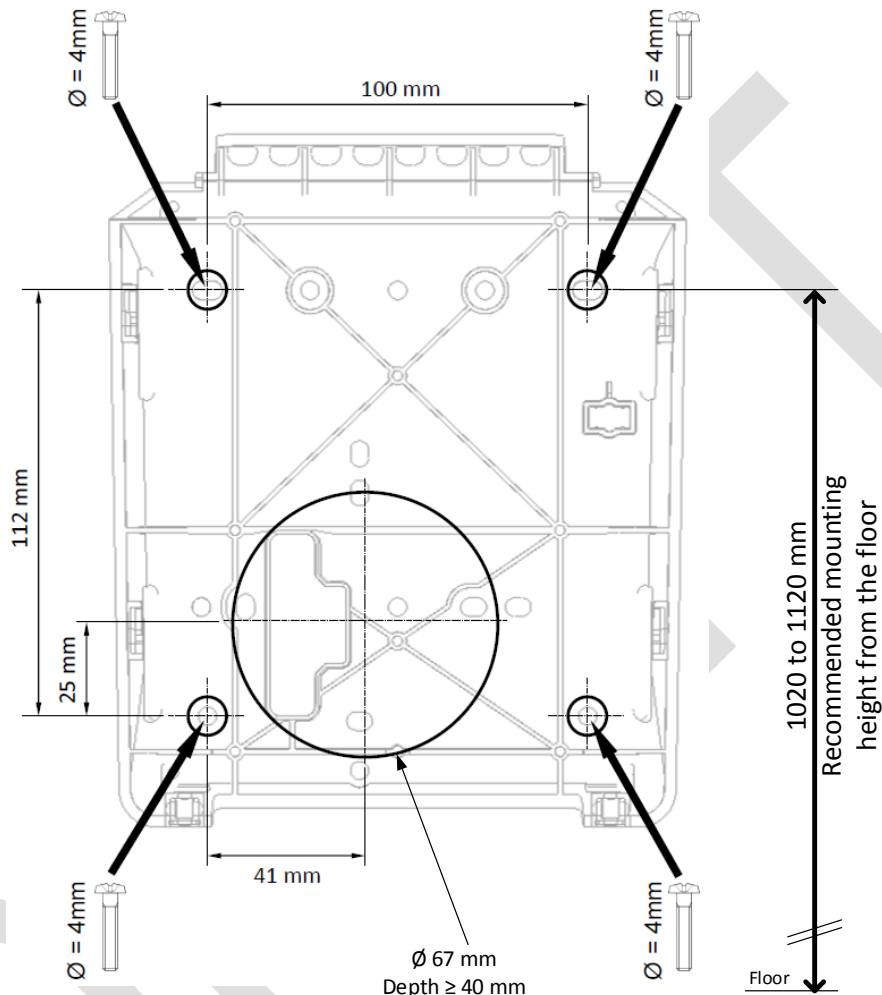

**Figure 7: Drilling template**

If not present, drill in the wall a hole with a diameter adapted to the width of the terminal and the cable to be hosted in (see Figure 7: Drilling template. This template can be found in the Quick Installation Guide).

The 67 mm diameter hole (cf. drilling template) should be at least 40 mm deep in order to fit the connections and cables. A deeper hole is recommended is possible, to make the connection process easier.

Confirm the presence inside the hole of all the cables needed for the electrical installation (see **Erreur ! Source du renvoi introuvable.**)

Drill in the wall 4 holes with a diameter adapted to screws and fit them with the raw plugs (see Figure 7: Drilling template).



*Be sure that a sufficient space is reserved in the wall for the passage of cables, in particular for Ethernet.*

### 3.3.2 > Make the connections

Unscrew the connector from the device:

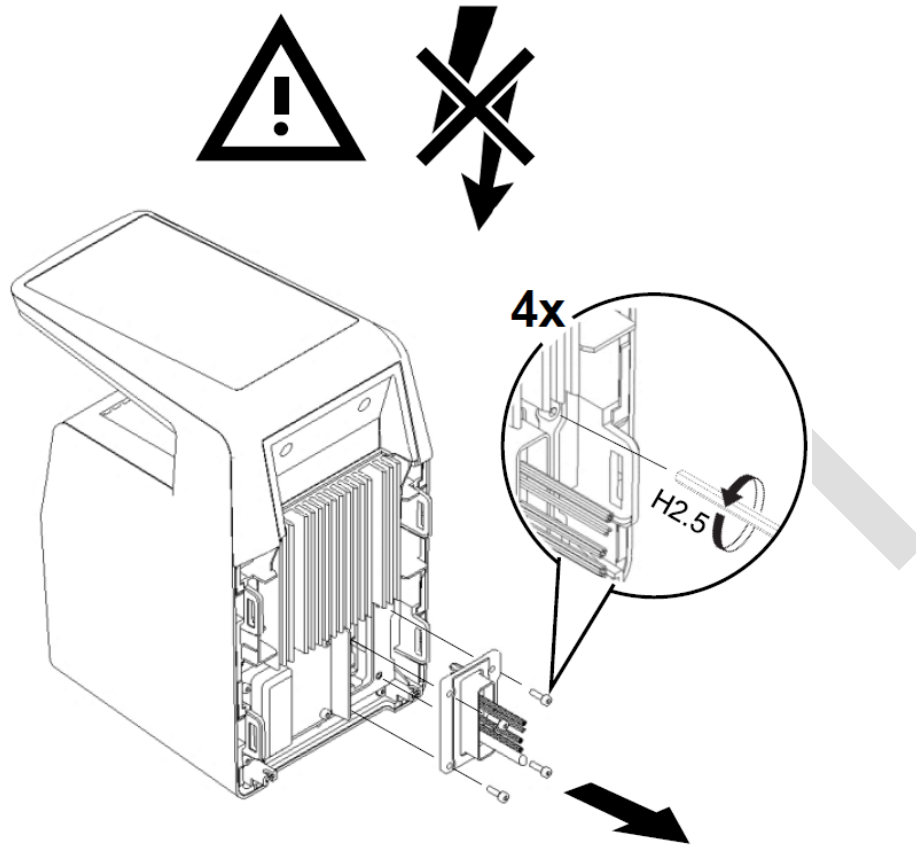

Fit the cables through the mounting plate:

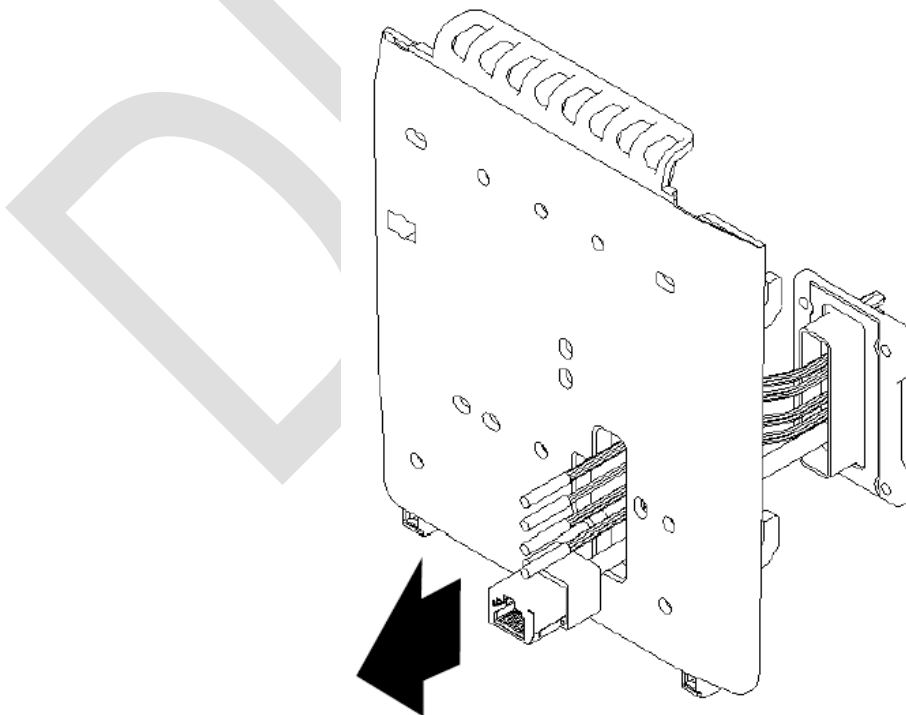

Then connect the cables:

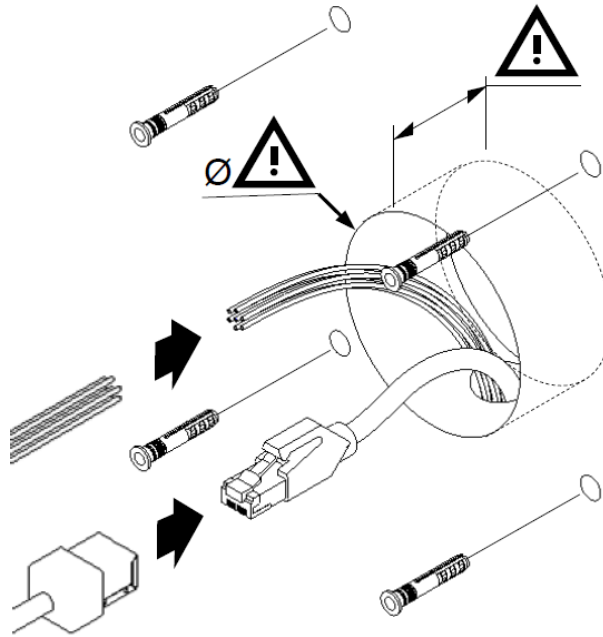

Before cabling the product, remove the connector by cutting cables in the middle of heat shrink tube. Please refer to section 4 / for explanations of how cables/wires should be connected, according to wire color code.

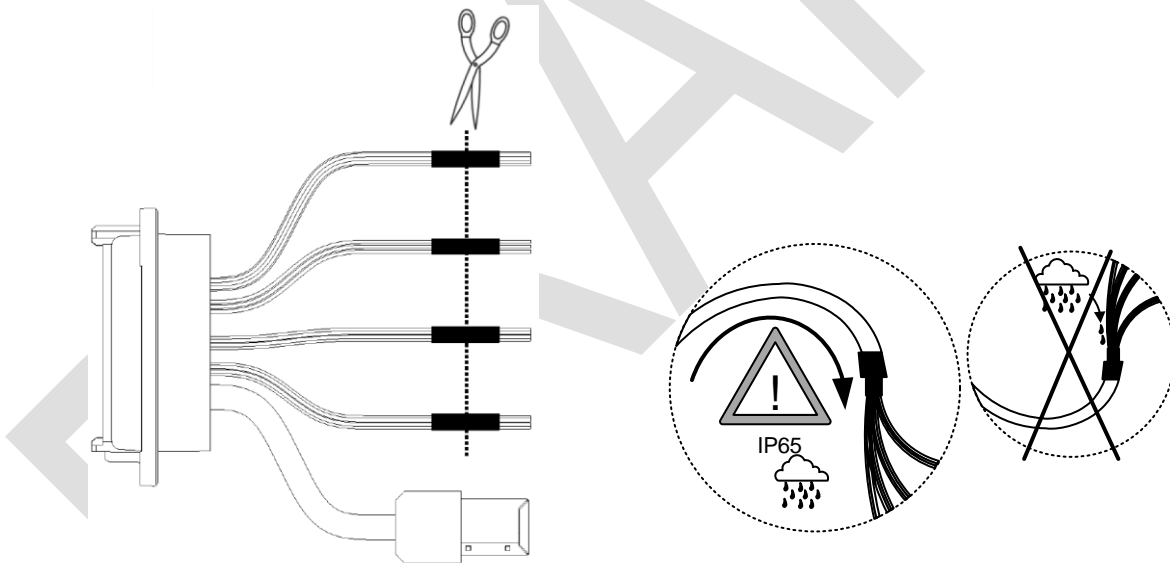

Figure 8: Cable preparation : cable position for water tightness

Cable for wiring shall be AWG 20 to 24, length shall be adapted to the size of the hole in the wall, to terminal connections, and to the distance between the electric source and the terminal itself.



*To ensure water tightness, be sure to bend the cable downward.*

For test purpose, it is possible to use the existing connector without cutting it. This connector mates with Molex PCB header reference 5016452620. The pinout of this connector is described in this document in section 4 /.

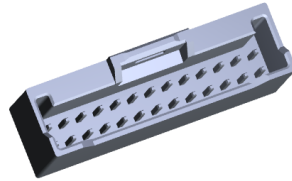

*The pinout indications that you can see on the labels of the cable shall NOT be taken into account as they correspond to the OTHER connector on the device side. Please use only the pinout information given in this document in section 4 /.*

### 3.3.3 > Attach the base plate on the wall

Fix the base plate on the wall with the 4 screws.

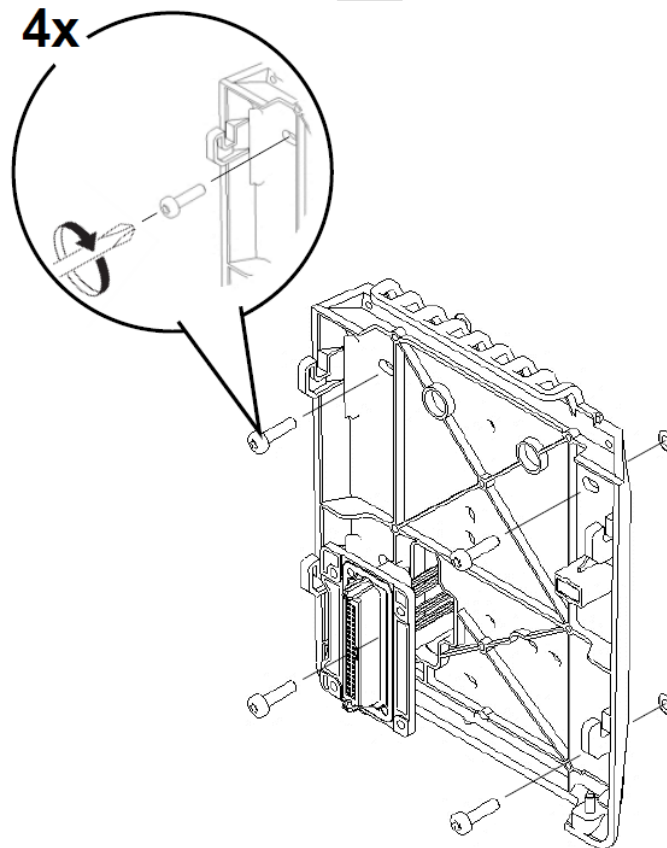

### 3.3.4 > Attach the device on the base plate

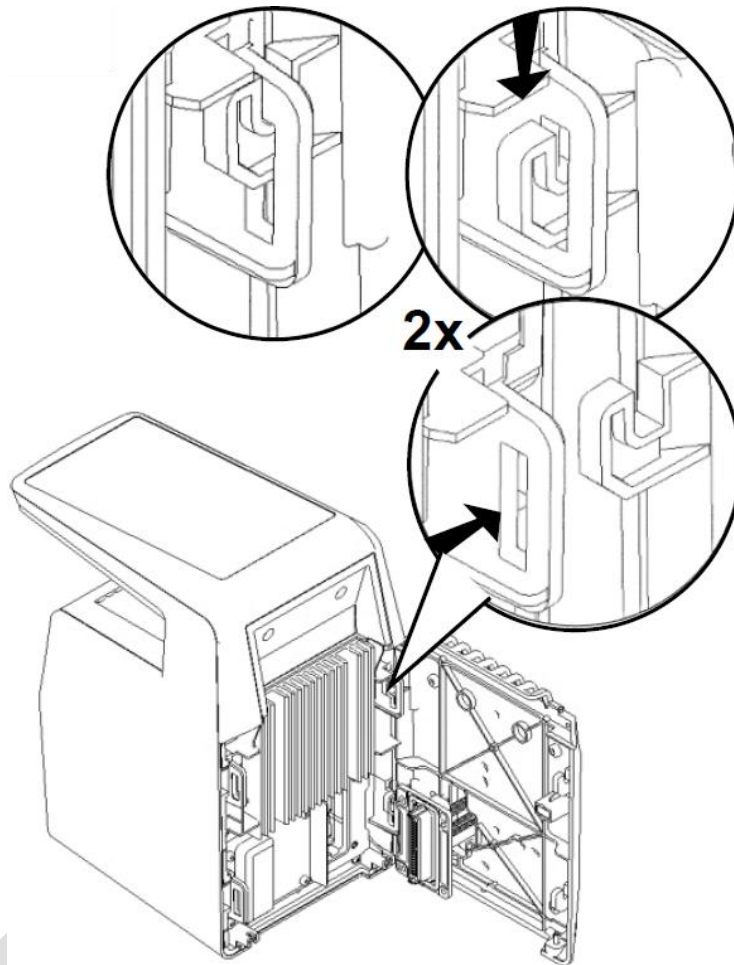

### 3.3.5 > Connect the connector assembly on the device

Attach the connector assembly on the device with the 4 screws.

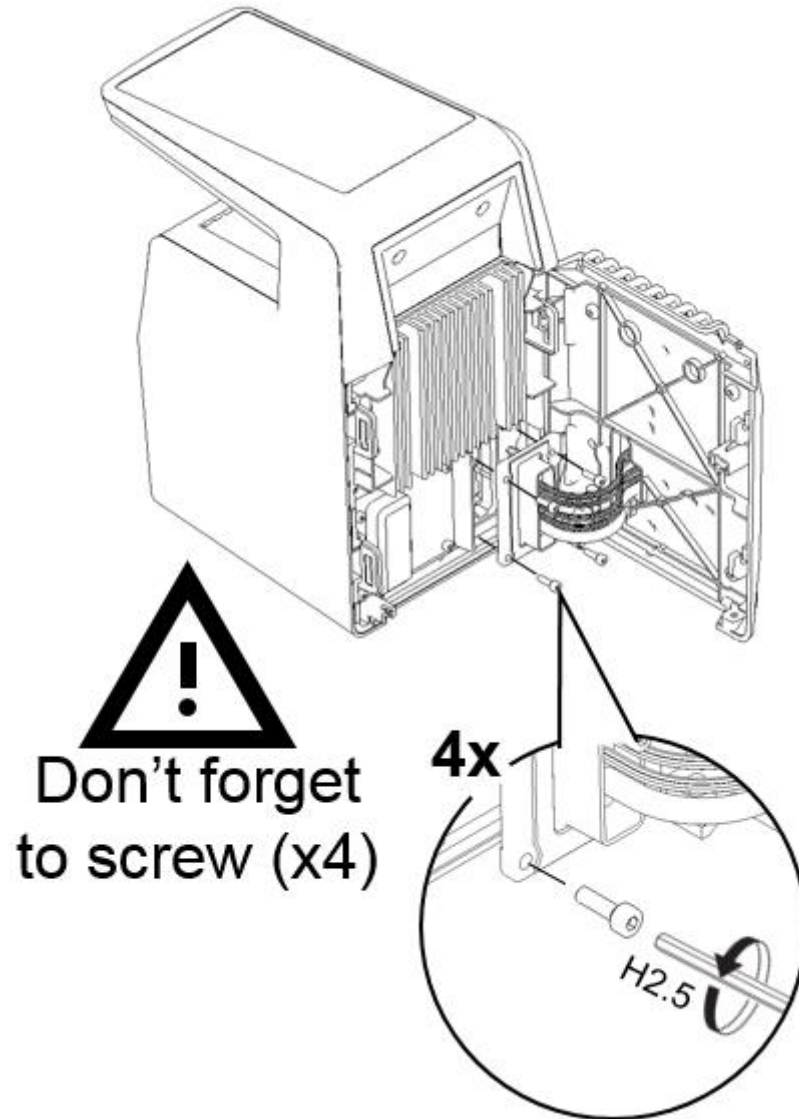

### 3.3.6 > Close the device on the base plate

Detach the device from the plate: first lift the device upwards, then pull it towards you, and hold it.

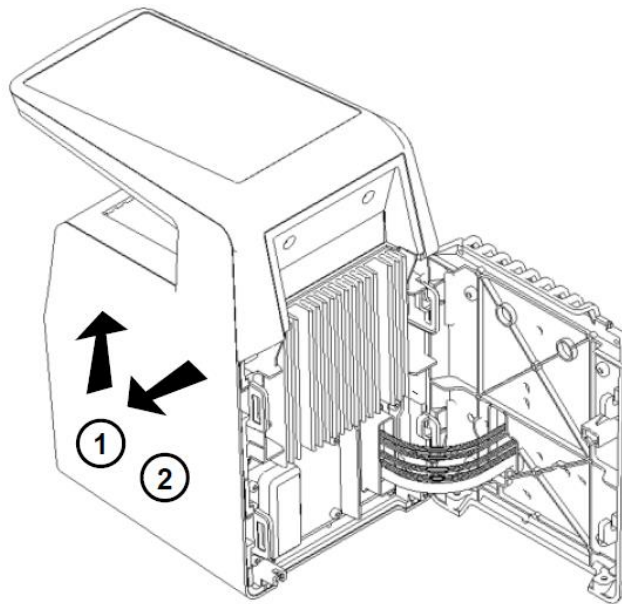

*Do not try to turn the product directly while it is attached on the base plate, as this would definitely damage the plate and the device !*

Then rotate the device 90° to align it in the final position in front of the plate. Push the device towards the wall, then downwards until the device is locked on the plate.

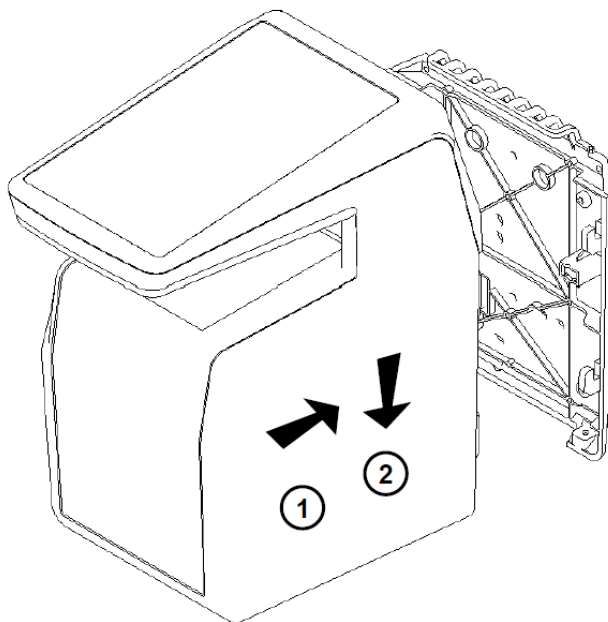

Then to secure the device on the plate, attach the last screw on the bottom of the device:

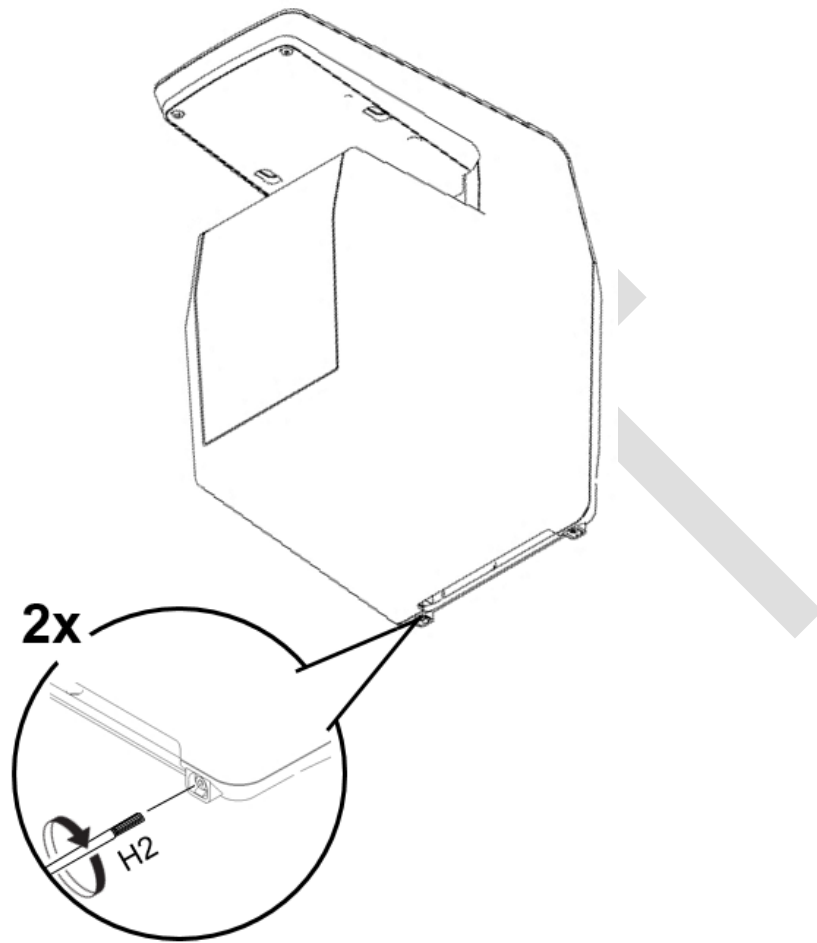

The hardware installation of the product on the wall is complete !

Power can be switched ON just after closing it. If the product has to be stored for a long time (more than 48 hours), don't forget to restore its configuration before use.



---

## 4 / Electrical interface

DRAFT

## 4.1 > Wiring overview



Before proceeding, make sure that the person in charge of installation and connections is properly connected to earth, in order to prevent Electrostatic Discharges (ESD).



Power supply ground shall not be used for peripheral ground. All other grounds can be used indifferently.

Note that all connections of the MorphoWave Compact terminal described hereafter are of SELV (Safety Electrical Low Voltage) type.

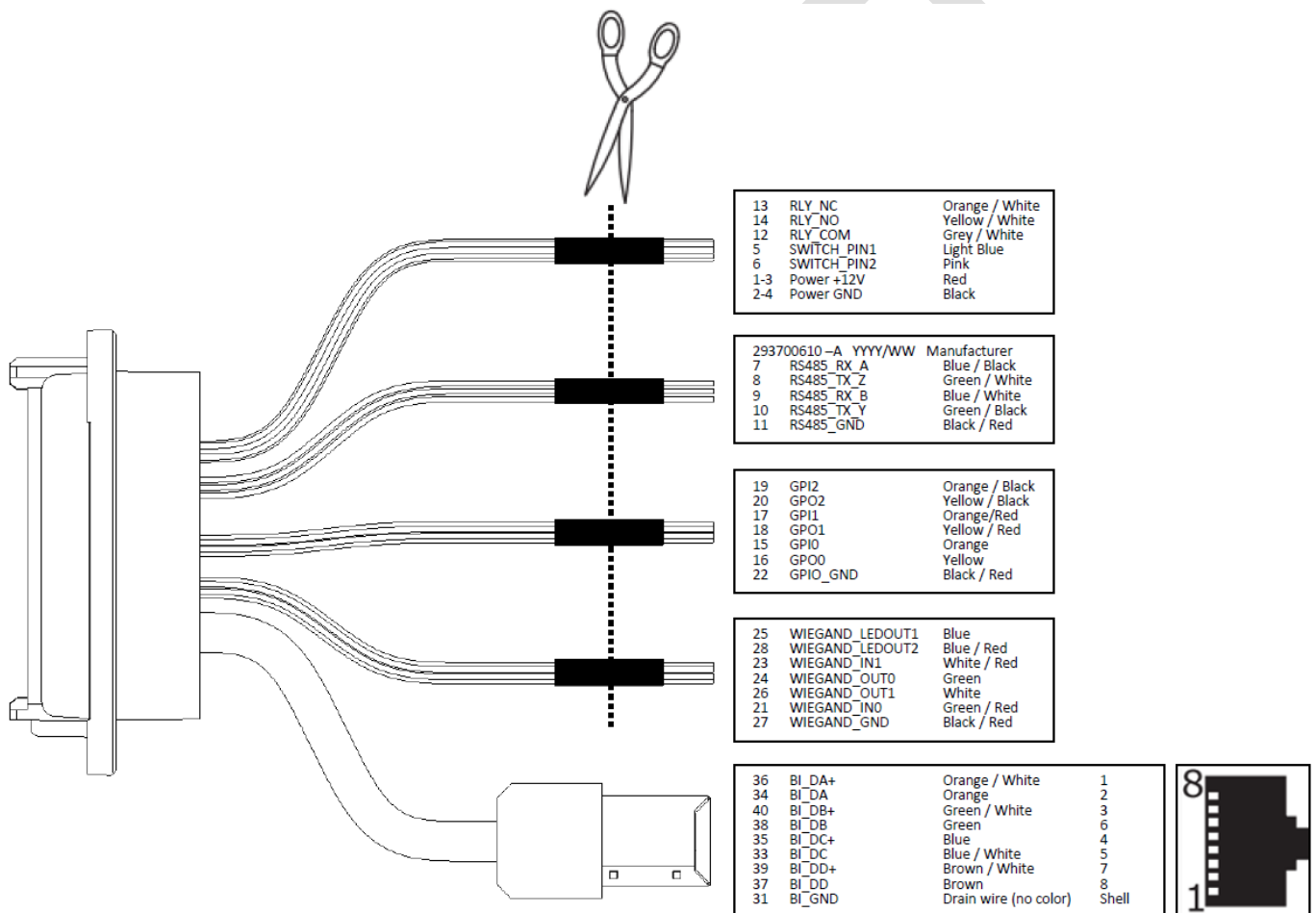

Figure 9: Cabling layout

## 4.2 > Power Supply

PoE+ and external power supply are not used at the same time: if both power supplies are used, priority is given to external power supply. If external power supply is shut down, switch to PoE+ without reboot is not guarantee.

### External Power supply

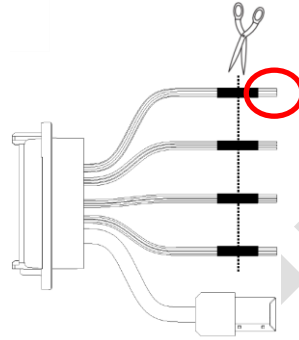

Figure 10: Power supply wiring

1-3	Red	Power Supply 12-24V DC	In	Positive 12-24 Volts, power supply
2-4	Black	Power ground	In	Ground power supply

The External power supply

- | Must comply with IEC 60950-1 standard marked Class 2, Limited Power source (LPS)
- | 12V to 24V Dc (regulated and filtered) 2.5 Amp min at 12V.
- | If sharing power between devices, each unit must receive 2.5A (e.g. two units would require a 12vDC, 5A supply).

IDEMIA recommends using a 24V power supply and AWG16 gauge cable. The voltage measured on the product block connector of the terminal must be equal to 12V-24V (-15% / +10%).

The voltage drop due to the cable shall be taken into account. The table below shows as an example the maximum distance between power supply and one (1) unique device, depending on cable gauge and power supply rating.

Gauge AWG	Section (mm <sup>2</sup> )	Maximum distance (meters) vs power source rating		
		12V $\pm$ 10%	12V $\pm$ 5%	24V $\pm$ 10%
16	1.31	9 m	20 m	300 m
18	0.82	6 m	12 m	200 m
20	0.52	3 m	8 m	120 m
22	0.32	2 m	5 m	75 m



*If several terminals are powered by the same cable, make sure to select a wire gauge that complies with maximum voltage drop, cable length, and power source minimum voltage rating.*

### *PoE+ (Power over Ethernet Plus)*

MorphoWave Compact terminal's power supply can also be provided by the Ethernet using RJ45 connection (Power over Ethernet Plus mode - IEEE802.3at type 2 compliant).

The terminal may be powered via a UL 294B PSE PoE+ Limited power source with a range of 48VDC (-10% /+15%). UL 294 compliance was verified with PoE+ (PSE-Power Sourcing Equipment manufacturer Microsemi, part number PowerDsine 9501G).



*If several terminals are powered through the same PoE+ switch, make sure the switch is capable of providing enough power to each device (25W).*



*Some functions are available ONLY with an external and not with PoE power supply: Wi-Fi, SAM, PIV/TWIC. External DC power is required for these features.*

DRAFT

## 4.3 > Output Relay

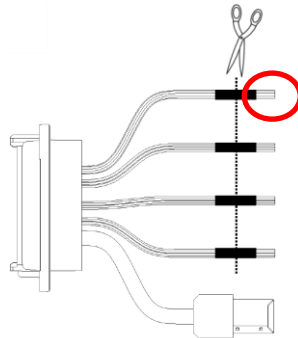





Figure 11: Output relay wiring

14	Yellow / White	RLY_NO		Contact relay (normally open)
12	Grey / White	RLY_COM		Contact relay common
13	Orange / White	RLY_NC		Contact relay (normally closed)

### Nominal characteristics of relay

Load characteristics:

- | 1 A max @ 30 VDC (according to the safety extra low voltage requirements independently of the power supply),
- | Resistive load or inductive load; see warning information hereafter for inductive load,
- | The internal relay is designed for at least 100 000 cycles (resistive load).



*Inductive load management requires a parallel diode for a better contact lifetime.*

### Example of connection for electrical door locks

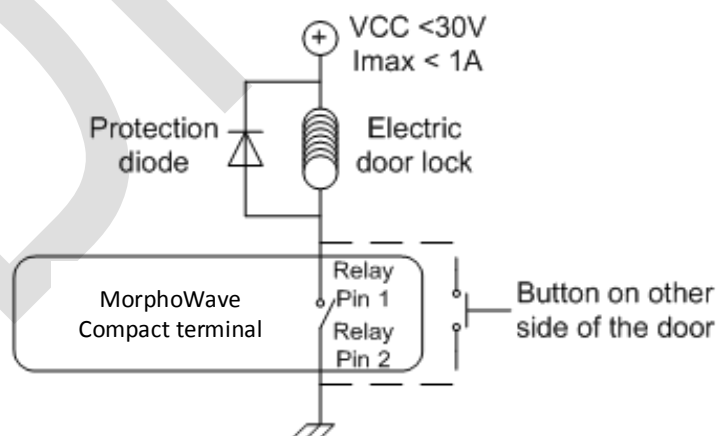

Figure 12: Example of electric latch connection

## 4.4 > Tamper Switch

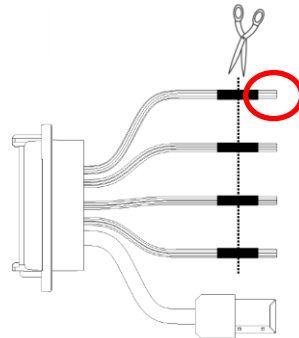



Figure 13: Tamper switch wiring

5	Light Blue	SWITCH_PIN1		Tamper switch contact
6	Pink	SWITCH_PIN2		Strip on tamper switch

### *Operating principle for the switch*

- | Product installed on the wall plate: switch enabled (contact closed).
- | Product opened (rear connectors accessible): switch disabled (contact open).

### *Nominal characteristics of switch block*

100 mA at 30 VDC max (Resistive load) according to the safety extra low voltage standard.



*This MorphoWave Compact terminal is part of security system; it is customer's responsibility to connect the tamper switch (contact) to physical access controller, in order to prevent the access to the connector blocks.*

## 4.5 > Wiegand wiring

### Wiegand input

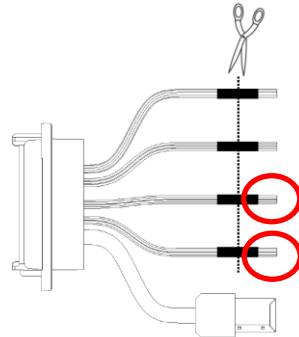

**Figure 14: Wiegand input wiring**

21	Green / Red	WIEGAND_IN0	In	Wiegand IN D0 (Output type required: Open drain or 5V+/-5%)
23	White / Red	WIEGAND_IN1	In	Wiegand IN D1 (Output type required: Open drain or 5V+/-5%)
16	Yellow	GPO0	Out	Wiegand LEDIN (typical = 5VDC) (option)
27	Black / Red	WIEGAND_GND		Ground for Wiegand



*If pull-up's to 12V have been added on Wiegand IN D0 and Wiegand IN D1 inputs on a previous installation with a MorphoAccess® 500 Series terminal, these resistors must be removed to avoid any damage to the MorphoWave Compact terminal.*

## 4.6 > Wiegand output

The following figure shows how to cable the wires of the serial port of the terminal for the Wiegand protocol

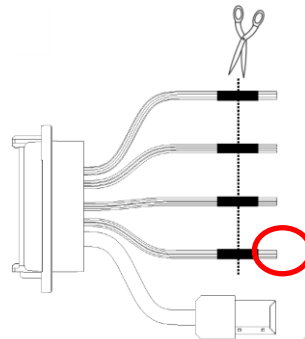

**Figure 15: Wiegand output wiring**

24	Green	WIEGAND_OUT0	Out	Wiegand OUT D0 (5V TTL)
26	White	WIEGAND_OUT1	Out	Wiegand OUT D1 (5V TTL)
25	Blue	WIEGAND_LEDOUT1	In	Wiegand LED IN 1 (option): panel feedback (Output type required: Open drain or 5V+/-5%)
28	Blue / Red	WIEGAND_LEDOUT2	In	Wiegand LED IN 2 (option): panel feedback (Output type required: Open drain or 5V+/-5%)
27	Black / Red	WIEGAND_GND		Ground for Wiegand

The use of LED1 and LED2 wires is described in the paragraphs below.

### *The controller supports neither LED1 nor LED2 signals*

When the access controller has no relay contact to provide an answer to the MorphoWave Compact terminal, then the decision to emit either the “access granted” signal or the “access denied” signal is taken by another way. It is either the MorphoWave Compact terminal itself that decide, or it waits for the access controller answer through the local area network (TCP), or on the serial port in (RS485 or RS422).

It is strongly recommended to disable the LED IN feature, to avoid any interference on MorphoWave Compact terminal behavior.

### *The controller supports only LED1 signal*

When the access controller has only one relay contact which is dedicated to the “access granted” answer, this one must be connected between the LED1 and GND wires. The LED1 wire is set to the low level by closing the contact between the LED1 and the GND wires, and it means “access granted”.

The MorphoWave Compact terminal uses the timeout of the wait for a low level on the on LED1 wire or LED2 wire as “access denied” answer.

To minimize at most the waiting time of the user, the MorphoWave Compact terminal timeout value, must be adjusted to a value a little bit higher than the maximal value of the controller response time.

**Warning:** if the LED2 wire is connected, it must be constantly maintained in the high state.



### *The controller supports LED1 and LED2 signals*

When the controller supports one relay contact for each of the possible answers then:

- | The « access granted » contact must be connected between the LED1 and the GND wires of the terminal
- | The « access denied » contact must be connected between the LED2 and the GND wires of the terminal.

The MorphoWave Compact terminal considers that:

- | The answer of the controller is "access granted", when the controller puts the LED1 wire to the low state (by closing a contact between the LED1 and the GND wires), **and leaves the LED2 wire to the high state.**
- | The answer of the controller is "access denied", when the controller puts the LED2 wire to the low state (by closing a contact between the LED2 and the GND wires), **whatever is the state of the LED1 wire.**

The MorphoWave Compact terminal also considers that the answer of the controller is "access denied" in case of time-out while expecting for a closure between LED1 and GND wires, or between LED2 and GND wires.

## 4.7 > Serial port wiring

### DataClock Input

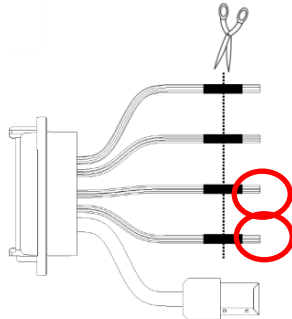

**Figure 16: Serial port wiring – DataClock Input**

21	Green / Red	WIEGAND_IN0	In	Data (Output type required: Open drain only)
23	White / Red	WIEGAND_IN1	In	Clock (Output type required: Open drain only)
16	Yellow	GPO0	Out	Card present signal (if configured, only one selectable for Morpho Legacy)
27	Black / Red	WIEGAND_GND		Ground for Wiegand

### DataClock Output

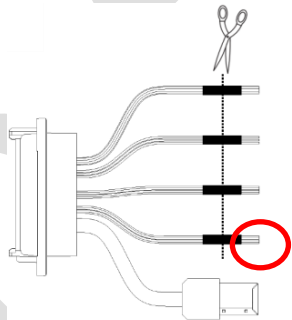

**Figure 17: Serial port wiring – DataClock Output**

24	Green	WIEGAND_OUT0	Out	Data ( 5V TTL )
26	White	WIEGAND_OUT1	Out	Clock ( 5V TTL )
25	Blue	WIEGAND_LEDOUT1	In	LED IN 1 (option): panel feedback (Output type required: Open drain or 5V+/-5%)
28	Blue / Red	WIEGAND_LEDOUT2	In	LED IN 2 (option): panel feedback (Output type required: Open drain or 5V+/-5%)
27	Black / Red	WIEGAND_GND		Ground for Wiegand

## RS485

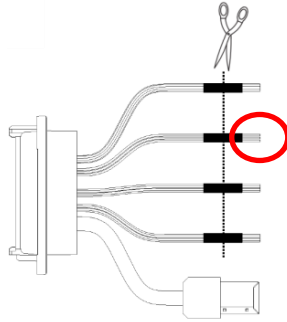

**Figure 18: Serial port wiring – RS485**

7	Blue / Black	RS485_RX_A	In/Out	RS485 Rx/Tx non inverting signal
9	Blue / White	RS485_RX_B	In/Out	RS485 Rx/Tx inverting signal
11	Black / Red	RS485_GND		Ground

RS485 implementation is limited to half-duplex communication. So only Tx+, Tx- and ground reference signals are necessary.

Depending on the RS485 network, an impedance adaptation may be required.

For farthest terminal, a 120-Ohms resistor termination may be added outside the terminal between TX+ and TX-.

## RS422

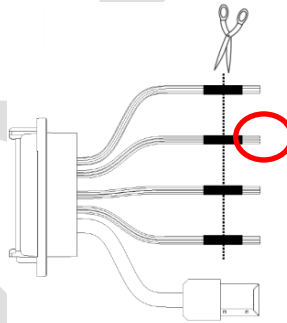
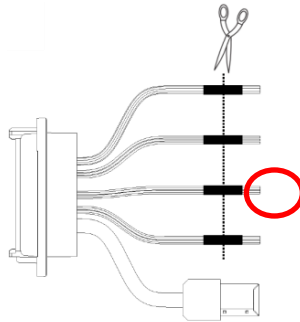

**Figure 19: Serial port wiring – RS422**

7	Blue / Black	RS485_RX_A	In	RS422 non inverting Receive
9	Blue / White	RS485_RX_B	In	RS422 inverting Receive
10	Green / Black	RS485_TX_Y	Out	RS422 non inverting Transmit
8	Green / White	RS485_TX_Z	Out	RS422 inverting Transmit
11	Black / Red	RS485_GND		Ground

RS422 interface is a full duplex communication.

## 4.8 > GPIO wiring



**Figure 20: GPIO wiring**

19	Orange / Black	GPI2	In	Digital Input (1,8V to 5V)
20	Yellow / Black	GPO2	Out	Digital Output (5V – 5mA max)
17	Orange / Red	GPI1	In	Digital Input (1,8V to 5V)
18	Yellow / Red	GPO1	Out	Digital Output (5V – 5mA max)
15	Orange	GPI0	In	Digital Input (1,8V to 5V)
16	Yellow	GPO0	Out	Digital Output (5V – 5mA max)
22	Black / Red	GPIO_GND		Ground

### Single Door Access Control (SDAC) implementation

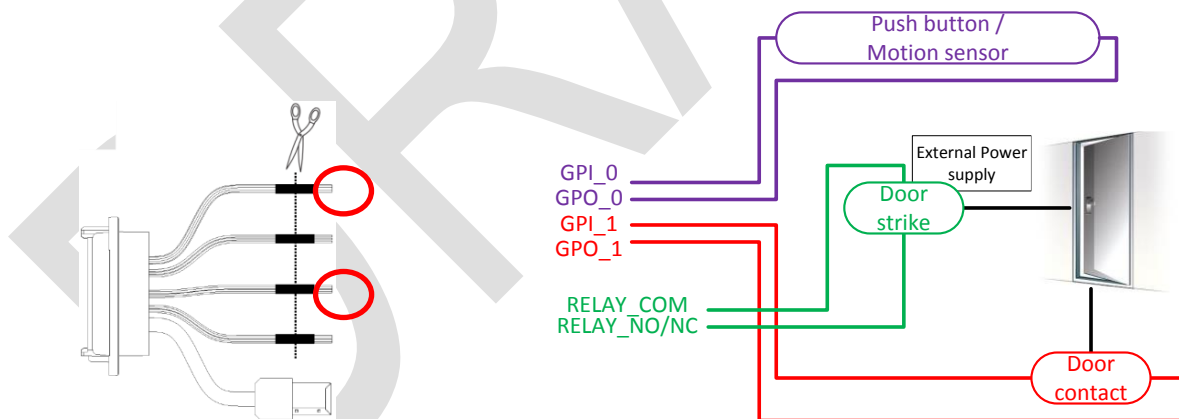

**Figure 21: SDAC wiring**



*If door contact is not used, GPI1 and GPO1 shall be connected together*

## 4.9 > Ethernet connection

Use a category 6 shielding cable (120 Ohms) or better. It is strongly recommended to insert a repeater unit every 90 m.

### Recommendations for RJ45 wiring

Pin	1	2	3	4	5	6	7	8
<b>Signals</b>	Data pair 1	Data pair 1	Data pair 2	NC/POE pin dedicated (+)	NC/POE pin dedicated (+)	Data pair 2	Ground/ pin dedicated (-)	NC/POE pin dedicated (-)
<b>EIA / TIA T568B Colors</b>	White orange	Orange	White green	Blue	White blue	Green	White brown	Brown
<b>EIA / TIA T568A Colors</b>	White green	White green	White green	White green	White green	White green	White green	White green
<b>Corel L120 Colors</b>	Grey	White	Pink	Orange	Yellow	Blue	Purple	Brown

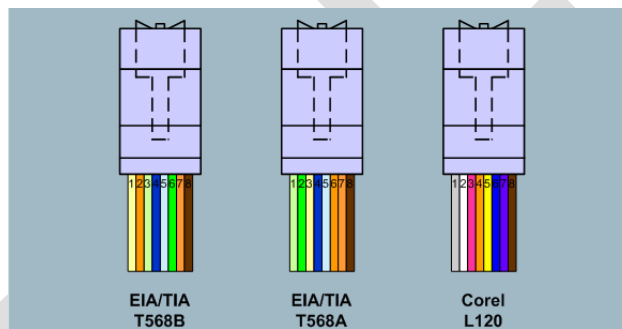

Figure 22: RJ45 wiring

RJ45 plug pinout is compliant with 10/100 base T, IEEE802.3 Specification. Product is compliant also with MDI or MDI-X.



*Ethernet cable shall be shielded*

Ethernet interface can be used to power the MorphoWave Compact terminal through PoE+ (Power Over Ethernet Plus - IEEE802.3at type 2 mode). According to the PoE+ standard two modes are available: power on data pins and power on dedicated pins.

Use either one of these modes depending on PoE+ implementation on your local Ethernet network.



*Some functions are available ONLY with an external and not with PoE power supply: Wi-Fi, SAM, PIV/TWIC. External DC power is required for these features.*

### Default Ethernet configuration

By default, MorphoWave Compact terminal is configured in STATIC mode with the following configuration:  
IP Address : 192.168.1.10; Gateway Address : 192.168.1.254; Subnet Mask : 255.255.254.0

## 4.10 > Internal USB connection

Remove the 4 screws of the cover, as shown on the following drawing. Then remove the cover.

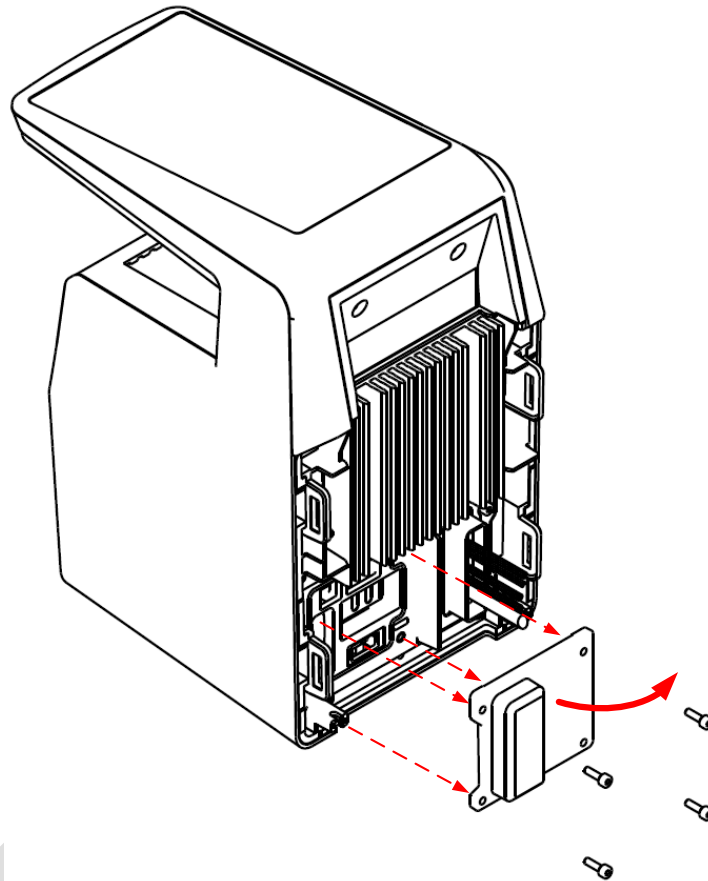

Then you can see a Mini USB plug.

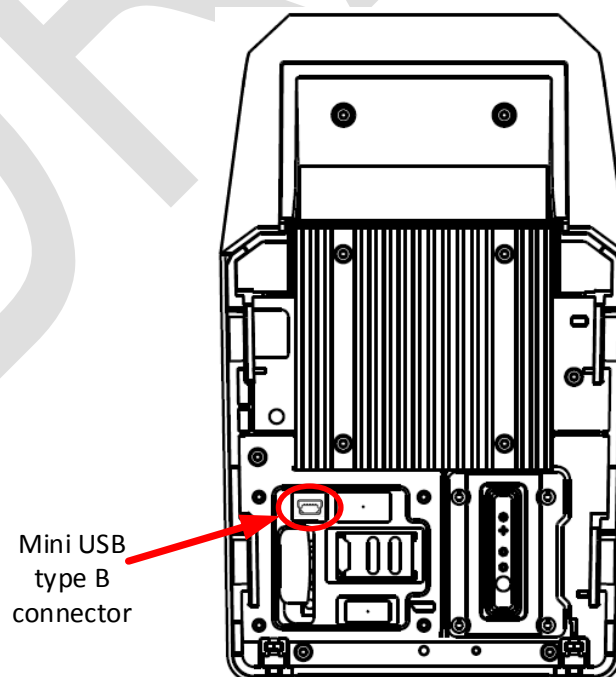

**Figure 23: Internal USB connection**

The internal Mini USB-type B can be used for administration only to connect a mass storage USB key (with a standard Mini USB-type B / USB-type A female OTG adapter).

This cable can be found in Idemia catalogue with ref TBD.

Please refer to MorphoWave Compact Administration Guide for more information.



*USB connection is limited to USB key connection (power consumption shall not exceed 200mA)*

DRAFT

## 4.11 > Wi-Fi™ dongle installation

Wi-Fi™ dongle shall be installed inside the product and connected to the internal USB Mini B (at the rear of the terminal) using Idemia cable provided in the kit.

Product integrating Wi-Fi™ dongle shall not be exposed to temperature exceeding 35°C and shall not be exposed to direct sun.

Wi-Fi™ feature requires the product to be powered from an external DC 12V to 24V power supply (the PoE+ doesn't provides enough power for both the terminal and the Wi-Fi™ dongle).

Only Wi-Fi™ USB dongle delivered by Idemia (kit reference 293686787, containing the dongle and the cable) may be installed with the terminal for WLAN (Wireless Local Area Network) operation.

Remove the cover on the rear panel:

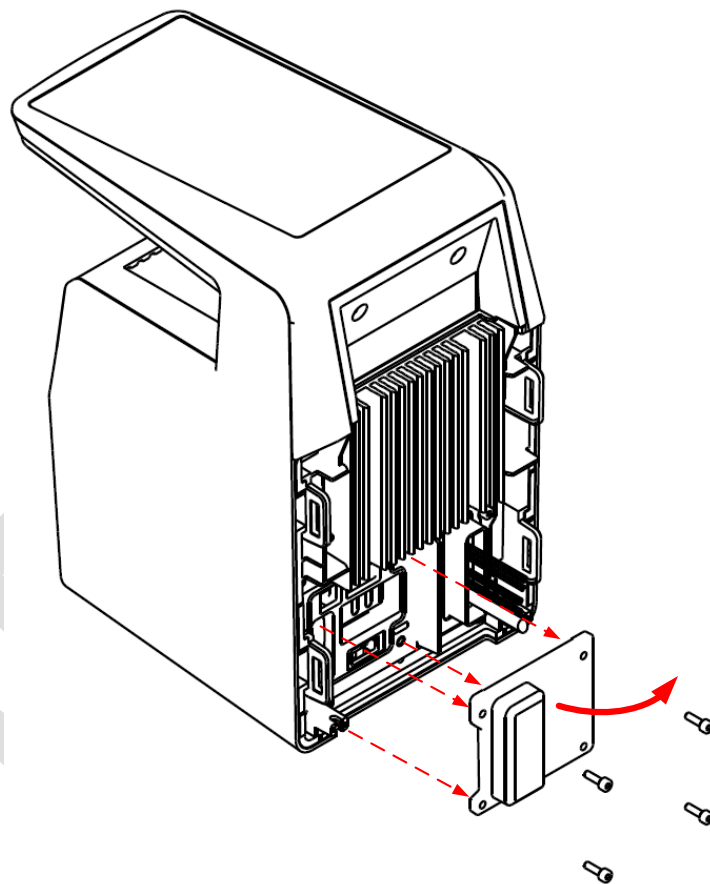



Then plug the Wi-Fi™ dongle on the provided cable, connect the cable on the Mini-USB socket, and fit the dongle inside the hole, as described on the following picture:

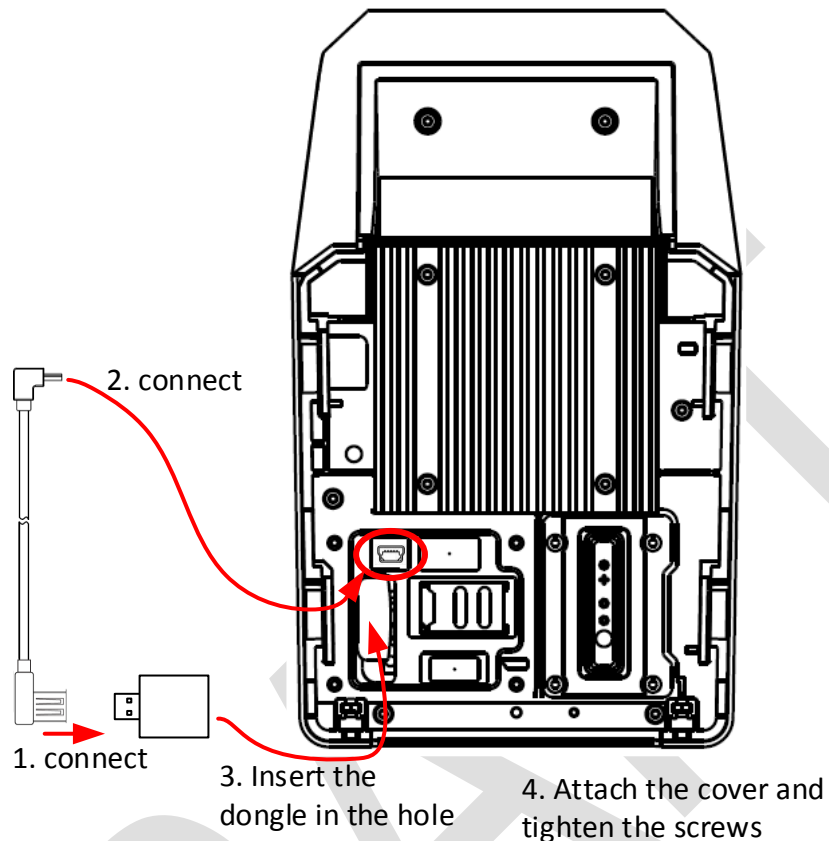

**Figure 24: Wi-Fi™ dongle installation**

Close the product with the cover and tighten the 4 screws.

---

## 5 / User interface

DRAFT

## 5.1 > Modes for controlling access rights

### 5.1.1 > Introduction

The MorphoWave Compact terminal offers several methods for controlling access rights: it needs to be configured in one of the following four modes:

- | Identification mode,
- | Authentication mode (requires a contactless smartcard reader in the terminal),
- | Multi-factor mode (requires a contactless smartcard reader in the terminal),
- | Proxy mode

Refer to MorphoWave Compact Administration Guide for more information on Access Control.

### 5.1.2 > Identification mode

The Identification process of the MorphoWave Compact terminal proceeds by comparison of the biometric data of the finger placed on the biometric sensor, with all the biometric data stored in the database.

It means that the biometric data of the allowed users must be stored in the internal database before they can request the access on the terminal. This biometric data is acquired either directly on the terminal (using the embedded), or on an enrolment system using the same type of biometric sensor.

The access control by identification process is started when a finger is detected on the biometric sensor

When the user requests the access, his identity is unknown, and it is the terminal that searches for his identity. The terminal grants the access if a match is found (the user is identified); otherwise the access is denied (the user remains unknown).

For further information, please see the "Identification mode" section in the MorphoWave Compact Administration Guide.

### 5.1.3 > Authentication (verification) mode

Unlike the "identification" mode, the user identity must be known in order to execute the authentication process.

Indeed, authentication is an identity verification process: the user provides his identity and the terminal checks it with the relevant process.

This mode doesn't compare the user's data to the data of several users: it compares the data provided by the user with the reference data provided by the same user during enrollment phase. The data can be on a card presented to the terminal or in a database and ID is provided by the user.

Access is authorized if the terminal finds a correspondence.

For further information, please see the "Authentication mode" section in the MorphoWave Compact Administration Guide.

### 5.1.4 > Multi-factor mode

In this mode, the "identification" and "authentication" modes are available simultaneously; the user decides which control method will be used:

- | by placing his finger on the sensor, thereby triggering the identification process,
- | by placing his contactless card on the reader, thereby triggering the authentication process,

This is the default mode for terminals fitted with a contactless smartcard reader.

For further information, please see the "Multi-factors method" section in the MorphoWave Compact Administration Guide.

## 5.1.5 > Proxy mode

The Proxy mode is an operating mode where the access control main application is located in a distant system. This is not a standalone mode like Identification and Authentication modes.

It means that the terminal becomes a slave of the host system application. The access control application is running on the host system and uses MorphoWave Compact terminal high level functions:

- | Identification function
- | Authentication function
- | Read data on a contactless card
- | Access control result signal command

The MorphoWave Compact terminal is driven through an Ethernet (or Wi-Fi™) link using TCP, SSL or TLS protocol.

The MorphoWave Compact terminal acts as a server: it is either waiting for a command or executing a command.

The commands allowed by the MorphoWave Compact terminal are described in the MorphoWave Compact Host System Interface Specification document.

For further details about SSL or TLS on the MorphoWave Compact terminal, please refer to the MorphoWave Compact Administration Guide.

## 5.1.6 > External database mode (also called polling mode)

When external database mode is activated, the MorphoWave Compact terminal does not verify user template in its local database. This mode is useful when the user templates are stored in external database.

When authentication is initiated on the terminal, the terminal will poll the user ID to external controller. On polling out the ID, the corresponding template (if exists) is fetched from the external database and is authenticated against user's biometric on the terminal. Once the template request is posted to the external database, the terminal shall wait for the finger template from the external database to start authentication. Further process shall be same as authentication.

### *Polling Process using buffer:*

- | The user's input ID will be queued in the terminal's queue, which is polled by external application.
- | External application waits for the User ID by polling the buffer. After getting an ID, it will search the template in database and send template to terminal for further authentication.
- | The user is authenticated by the external device and granted access accordingly.

MorphoWave Compact terminal also has distant commands to retrieve polling buffer status and polling buffer data. Refer to the MorphoWave Compact Host System Interface Specification document.

### *How to Activate?*

External database mode can be activated through Webserver > Complete Configuration, by setting "ucc.enable\_external\_database" parameter to 1. Only an admin user can activate polling mode. You can

refer to the MorphoWave Compact Host System Interface Specification document to know how to set this parameter.

### *Configuring the terminal*

MorphoWave Compact terminals are standalone biometric systems which offers advance features for access control. MorphoWave Compact terminals are equipped with a facility to support the MorphoAccess® and Bioscrypt legacy systems.

When MorphoWave Compact terminal is set in any of the legacy modes, it supports the database structures and configurations of the selected legacy system. When the terminal is booted for the first time, user can select any of the following modes:

DRAFT

## 5.1.7 > MorphoWave Compact native mode

MorphoWave Compact terminal is by default in native mode, that is named MA5G. It will support the new features and configurations only in the native mode.

**NOTA :** *When terminal mode is switched from MA5G to Morpho legacy mode, the entire configuration (excepted communication links) and all databases are erased*

**NOTA :** *The terminal is rebooted on mode change and factory settings are applicable.*

Once the product is configured in native mode, the following methods can be used to configure the terminal:

- | through the Ethernet interface (remote management)
- | through a Wi-Fi™ connection (license and dongle required)

Configuration procedures are described inside the MorphoWave Compact Administration Guide as follows:

- | Section 4: Terminal Configuration And Administration

## 5.1.8 > Anti-tamper / anti-pulling switches

Please refer also to “Tamper Switch” section.

These switches are activated as soon as there is enough pressure applied on the terminal against the wall. They are deactivated as soon as this pressure is not big enough, e.g. when the terminal is pulled out of the wall.

When the switches are deactivated, the MorphoWave Compact terminal acts as required by the related configuration key (see MorphoWave Compact Administrator / User Guide for key configuration description):

- | Ignore the event (default): useful during normal maintenance operations.
- | Send an alarm message to the Central Access Controller, through the usual channel of the access control result messages (Wiegand, DataClock, RS485, Ethernet or Wi-Fi™). An alarm switch (relay contact) is directly available on block terminal «tamper switch pins». Please refer to “Wiring overview” and to “Tamper Switch” sections.
- | Generate an audible alarm signal with the speaker and an alert message on the screen.

DRAFT

---

## 6 / Accessories, Software Licenses and PC Applications

DRAFT



## 6.1 > Compatible Accessories, Licenses and Software

The following items can be ordered directly to Idemia or to an official distributor, so as to enjoy all the features of your MorphoWave Compact terminal:

- | Power supply units,
- | Contactless smartcards: MIFARE® 1k, 4k; DESFire® 2k, 4k, 8k,
- | MA WI-FI PACK: containing a Wi-Fi™ USB dongle and a Wi-Fi™ license to activate Wi-Fi™ capability on your terminal,
- | User database size licenses (MA\_10K\_USERS, MA\_50K\_USERS, MA\_100K\_USERS): enabling database size upgrade from 3,000 to 10,000, 20,000, 50,000 or 100,000 users capacity (max 3 fingers per record) at creation of the database. Requires Micro SD card in the terminal.

DRAFT

## 6.2 > Compatible PC applications

MorphoWave Compact terminals are fully compatible with:

- | MorphoManager (version 11 or higher)
- | Morpho Integrator's Kit (MIK) software development kit (version 6 or higher).
- | MorphoBioToolBox (version 3.4.3 or higher)

Using Legacy Morpho mode, MorphoWave Compact is also compatible with:

- | MEMS (version 7.3.1 or higher),
- | MIK (version 5.4 or higher),

The limitations in Morpho Legacy mode are described in the following document:

- | MorphoWave Compact Release Note - Legacy Morpho limitations

DRAFT

---

## 7 / Recommendations

DRAFT

### *Global warning*

- | The manufacturer cannot be held responsible in case of non-compliance with the following recommendations or incorrect use of the terminal.

### *General precautions*

- | Do not attempt to repair your terminal yourself. The manufacturer cannot be held responsible for any damage/accident that may result from attempts to repair components. Any work carried out by non-authorized personnel will invalidate your warranty.
- | Do not expose your terminal to extreme temperatures.
- | Use your terminal with original accessories. Attempts to integrate unapproved accessories to the terminal will void your warranty.
- | Due to electrostatic discharge, and depending on the environment, synthetic carpet should be avoided in areas where the terminal has been installed.
- | Do not tilt the product.
- | Do not use blunt force on the product.
- | Do not attach anything to the product.
- | Do not place anything on the product.
- | Switch off the device before unplugging it.

### *Biometric performance*

- | Do not scratch the product, particularly on the glass, because the performance of the product depends of the state of the glass surface and its anti-reflective face.
- | Clean the glass every day to optimize performance of the product.
- | Avoid direct sun light on the product.

### *Areas containing combustibles*

- | It is strongly recommended that you do not install your terminal in the vicinity of gas stations, petroleum processing facilities or any other facility containing flammable or combustible gasses or materials.

### *Specific precautions for terminals equipped with a contactless smartcard reader*

- | It is recommended to install terminals equipped with a contactless smartcard reader at a certain distance (> 30cm) from metallic elements such as iron fixations or lift gates or radio product (such as contactless smartcard reader). Performances in terms of contactless badge reading distance will decrease when metallic elements are closer.

### *Ethernet connection*

- | It is recommended to use a category 5 shielding cable (120 Ohms). It is also strongly recommended to insert a repeater unit every 90m.
- | Extreme care must be taken while connecting Ethernet wire to the terminal block board since low quality connection may strongly impact Ethernet signal sensibility.
- | It is recommended to connect Rx+ and Rx- with the same twisted-pair wire (and to do the same with Tx+/Tx- and the other twisted-pair wire).

### *Date / Time synchronization*

- | The terminal clock has a +/-10 ppm typical time deviation at +25°C (roughly around +/- 6 sec per 48 hours). At lower and higher temperature (but within normal operating temperatures), deviation may be more important (worst case: - 14 seconds per 48 hours).

- | If the terminal is used in an application requiring high time precision, we recommend synchronizing regularly your terminal time with an external clock (using NTP). Every 24 hours is usually enough for most applications.
- | Please note that the date/time of the terminal is protected from power failure during at least 24 hours. If the duration of the power failure or power down is longer, the date/time of the terminal will be lost.

#### *Cleaning precautions*

- | Use a dry cloth to clean the terminal, especially the front face. It is recommended that the product be cleaned daily to ensure the best performance level over its lifetime.
- | The use of acid liquids, alcohol or abrasive materials is prohibited.
- | Use dry air spray to remove the dust out of the sensor glass.

DRAFT

---

## 8 / Annex 1 : finger placement recommendations

DRAFT

## 8.1 > Main principles

MorphoWave Compact is a biometric acquisition terminal which captures fingerprints by the applicant waving their hand through the active volume. The product can track and capture simultaneously up to 4 fingerprints at a maximum speed of 0.5m/s.

To acquire fingerprints, the applicant waves his hand between the product glass and protective cap as shown in the Figure below.



Note: The recommended hand wave direction is from right to left, even though the sensor will accept both directions.



## 8.2 > Capture recommendations

### Proper Use

Below are several illustrations and guidelines on how to best use your new MorphoWave Compact device.



1. **Insert your hand flat, palm down, from the front of the scanner**



2. **Slightly spread apart your fingers**



3. **Place your hand between the cover and the optical sensor**



4. **Position your fingertips according to the marking on the left/right side of the acquisition area**



5. **Slide your hand from right to left or left to right**



## Improper Use

The following illustrations show what NOT to do when using Finger on the Fly.



1. Do not place your hand upside down



2. Do not cross your fingers



3. Do not place your hand with fingers spread wide



4. Do not place your fingers tightly together



5. Do not place 2 hands inside



6. Do not place your hand on the cover



7. Do not touch the cover



8. Do not place your hand on the optical sensor



9. Do not place your hand on the edge of the optical sensor



10. Do not place your hand too far up on the optical sensor



11. Do not tilt your hand (left to right or fingertip to palm)"



12. Do not insert your hand fingers first from either the left or right side of the scanner



13. Do not swipe your hand too fast

---

## 9 / Annex 2 : Bibliography

DRAFT

## 9.1 > How to get the latest versions of documents

The last version of the documents can be downloaded from our web site at the address below:

[www.biometric-terminals.com](http://www.biometric-terminals.com)

(Login and password required).

To request a login, please send us an email to the address below:

[hotline.biometrics@morpho.com](mailto:hotline.biometrics@morpho.com)

DRAFT

## 9.2 > Documents about the MorphoWave Compact terminal

### *Documents about installing the terminal*

MorphoWave Compact Installation Guide,

Ref. 2018\_2000035853

This document describes terminal physical mounting procedure, electrical interfaces and connection procedures. This document is in English.

### *Documents about administrating / using the terminal*

MorphoWave Compact Quick User Guide,

Ref. 2018\_2000035854

This document gives a quick overview of the product and the basics of configuration and use. This document is in English.

MorphoWave Compact Administrator Guide,

Ref. TBD

This document describes the different functions available on the terminal and procedures for configuring the terminal. It also contains the full description of all the configuration parameters for the terminal. This document is in English.

MorphoWave Compact Parameters Guide,

Ref. TBD

This document contains the full description of all the terminal configuration parameters. This document is in English.

### *Documents for the developer*

MorphoWave Compact Host System Interface Specification,

Ref. TBD

This document describes the commands supported by the MorphoAccess® terminal. This document is in English.

MorphoWave Compact Remote Message Specification,

Ref. TBD

This document describes the format of messages sent by the terminal to a distant system. This document is in English.

### *Release note*

For each firmware version, a release note is published describing the new features, the supported products, the potential known issues, the upgrade / downgrade limitations, the recommendations, the potential restrictions...

---

## 10 / Annex 3 : Support

DRAFT

## 10.1 > Troubleshooting

*The terminal IP address is unknown or it is not possible to connect to the terminal*

Use terminal interface to configure a valid set of network parameters in your terminal.

*The sensor is switched off*

Check that the database contains at least one record.

Check that the identification mode is enabled.

*The terminal returns erratic responses to Ping commands*

Check the subnet mask.

Ask the network administrator for the correct value.

Check that each device connected to the network has a different IP address.

## 10.2 > Technical Support and Hotline

*North America:*

Mail: [cscenter@morpho.com](mailto:cscenter@morpho.com)

Tel: +1 888 940 7477

*South America:*

Mail: [cscenter@morpho.com](mailto:cscenter@morpho.com)

Tel: +1 714 575 2973

*South Africa:*

Mail: [sec.san.bio.support@morpho.com](mailto:sec.san.bio.support@morpho.com)

Tel: + 27 11 286 5855

*India:*

Mail: [support.morphoindia@morpho.com](mailto:support.morphoindia@morpho.com)

Tel: 0120-4699900

*Europe and rest of the world:*

Mail: [hotline-biometrics@morpho.com](mailto:hotline-biometrics@morpho.com)

Tel: +33 1 30 20 30 40

(9H00am to 5H30pm French Time, Monday to Friday)

*Web site*

For the latest firmware, software, document releases, and news, please check our websites :

- | **North and South America:** e-mailing [cscenter@morpho.com](mailto:cscenter@morpho.com) with your name, phone number, product serial number and “Send Links For MorphoWave Compact Documents” in the subject line
- | **Other countries:** please visit our web site [www.biometric-terminals.com](http://www.biometric-terminals.com) (To get your log in and password please contact your sales representative).

DRAFT



[www.idemia.com](http://www.idemia.com)



[www.idemia.com](http://www.idemia.com)

