



IEI Technology Corp.



MODEL:
IOVU-570M

**Panel PC, 5.7" Touch Screen, 520 MHz Marvell XScale PXA270,
Fast Ethernet, 2 x USB, 802.11b/g Wireless, RS-232/422/485
RoHS Compliant, IP 64 Protection**

User Manual

Rev. 1.00 – 17 September, 2010





Revision

Date	Version	Changes
17 September, 2010	1.00	Initial release

Copyright

COPYRIGHT NOTICE

The information in this document is subject to change without prior notice in order to improve reliability, design and function and does not represent a commitment on the part of the manufacturer.

In no event will the manufacturer be liable for direct, indirect, special, incidental, or consequential damages arising out of the use or inability to use the product or documentation, even if advised of the possibility of such damages.

This document contains proprietary information protected by copyright. All rights are reserved. No part of this manual may be reproduced by any mechanical, electronic, or other means in any form without prior written permission of the manufacturer.

TRADEMARKS

All registered trademarks and product names mentioned herein are used for identification purposes only and may be trademarks and/or registered trademarks of their respective owners.

Table of Contents

1 INTRODUCTION.....	1
1.1 OVERVIEW.....	2
1.2 BENEFITS	2
1.3 FEATURES.....	3
1.4 TECHNICAL SPECIFICATIONS	3
1.5 CERTIFICATIONS	4
2 DETAILED SPECIFICATIONS	5
2.1 FRONT PANEL.....	6
2.2 CONNECTOR PANEL.....	6
2.3 DIMENSIONS.....	8
2.4 POWER SUPPLY	9
3 UNPACKING	10
3.1 ANTI-STATIC PRECAUTIONS.....	11
3.2 UNPACKING PRECAUTIONS.....	11
3.3 UNPACKING CHECKLIST	12
4 INSTALLATION	13
4.1 INSTALLATION PRECAUTIONS	14
4.2 SD CARD INSTALLATION	14
4.3 EXTERNAL PERIPHERAL INTERFACE CONNECTORS.....	15
4.3.1 12 V~36 V DC Terminal Block	16
4.3.2 RS-232/422/485 Serial Port	16
4.3.2.1 Connecting the Serial Port	16
4.3.2.2 RS-232/422/485 Selection	17
4.3.2.3 Pinouts.....	18
4.3.3 USB Connectors.....	19
4.3.4 Ethernet Connector	20
4.4 MOUNTING THE SYSTEM	22
4.4.1 Wall Mounting	23

IOVU-570M Panel PC

4.5 SOFTWARE.....	25
4.5.1 Wireless AP.....	26
A CERTIFICATIONS	29
A.1 RoHS COMPLIANT	30
A.2 IP 64 COMPLIANT FRONT PANEL	30
B SAFETY PRECAUTIONS	31
B.1 SAFETY PRECAUTIONS.....	32
<i>B.1.1 General Safety Precautions</i>	<i>32</i>
<i>B.1.2 Anti-static Precautions</i>	<i>33</i>
B.2 MAINTENANCE AND CLEANING PRECAUTIONS	33
<i>B.2.1 Maintenance and Cleaning.....</i>	<i>33</i>
<i>B.2.2 Cleaning Tools</i>	<i>34</i>
B.3 FCC PRECAUTIONS	35
C HAZARDOUS MATERIALS DISCLOSURE	36
C.1 HAZARDOUS MATERIALS DISCLOSURE TABLE FOR IPB PRODUCTS CERTIFIED AS RoHS COMPLIANT UNDER 2002/95/EC WITHOUT MERCURY	37

List of Figures

Figure 1-1: IOVU-570M	2
Figure 2-1: Front Panel	6
Figure 2-2: IOVU-570M Peripheral Connectors	6
Figure 2-3: IOVU-570M Physical Dimensions (millimeters)	8
Figure 4-1: SD Card Installation	15
Figure 4-2: IOVU-570M Peripheral Connectors	15
Figure 4-3: Power Terminal Block	16
Figure 4-4: Serial Device Connector	17
Figure 4-5: Serial Port Mode Setting	18
Figure 4-6: Serial Port Pinouts	19
Figure 4-7: USB Connector	20
Figure 4-8: LAN Connection	21
Figure 4-9: Ethernet Connector	22
Figure 4-10: Wall-mounting Bracket	23
Figure 4-11: Chassis Support Screws	24
Figure 4-12: Secure the IOVU-570M	25
Figure 4-13: Wireless AP	26
Figure 4-14: Wireless Network Properties	27
Figure 4-15: Wireless AP Connected	27
Figure 4-16: IP Information	28

List of Tables

Table 1-1: Technical Specifications	4
Table 3-1: Package List Contents	12
Table 4-1: External Interface Connectors	15
Table 4-2: 12~36 V Power Connector Pinouts	16
Table 4-3: Serial Port Pinouts	19
Table 4-5: USB Connector Pinouts	20
Table 4-6: Ethernet Connector Pinouts	21
Table 4-7: Ethernet Connector LEDs	22

Chapter

1

Introduction

1.1 Overview



Figure 1-1: IOVU-570M

The IOVU-570M Panel PC comes with a 5.7" touch panel screen. It is powered by the 520 MHz Marvell XScale PXA270 processor and has 128 MB of SDRAM.

The IOVU-570M includes an SD card with Windows CE 5.0 installed. The package also includes a software development kit and documentation to help easily customize the operating system according to needs.

The IOVU-570M is an extremely low power Panel PC. The system is fanless, which allows quiet and reliable operation

1.2 Benefits

Some of the IOVU-570M benefits include:

- Customizable operating system to suit application needs.
- Less downtime from overheating because there are not fans to fail
- Cost savings with low power consumption
- Easy installation with a wide range of input voltages supported
- Can handle tough environments because of solid-state storage and IP64 protection of the front cover

IOVU-570M Panel PC

1.3 Features

The IOVU-570M features are listed below:

- 520 MHz Marvell XScale PXA270 processor
- 128 MB of SDRAM
- Two Ethernet ports
- Two USB ports
- One RS-232/422/485 serial communication connection
- Two built-in speakers
- 4-wire resistive touch panel
- 12-36 VDC input
- RoHS compliant

1.4 Technical Specifications

The IOVU-570M technical specifications are listed in Table 1-1.

Specifications	
System	
CPU	520 MHz Marvell XScale PXA270 processor
Memory	128 MB of SDRAM 1.0 GB SD card
Real-time Clock	Battery backup RTC
Watchdog Timer	Software programmable supports 1~255 sec. system reset
Reset	Reset button
Display	
Display Type	TFT LCD screen
Display Size	5.7"
Resolution	640 x 480, 262,000
Brightness	400 cd/m ²
Touch Panel	4-wired resistive touch panel

Specifications	
I/O and Communications	
Ethernet	2 x 10/100 Mb/s
Serial Ports	1 x RS-232/422/485
USB Interfaces	2 x USB host connectors
Audio	2 x 1.5 Watt speakers
Power	
Power Supply	12-36 VDC
Power Consumption	8.5 W
Environmental and Mechanical	
Operating Temperature	Minimum: -20°C (-4°F) Maximum: 60°C (140°F)
Humidity	5%RH to 90%RH (non-condensing)
Vibration	Operating Random Vibration Mode (MIL-STD-810F 514.5C-3) 1.Axes: 3 axs (Vertical / Transverse / Longitudinal). 2.10-500 Hz, 60min/axis. 3.Equivalent to Z:2.18 Grms X:1.6 Grms Y:1.96 Grms
Front Panel Color	Pantone Black C
Physical Dimensions	180 mm x 135.8 mm x 46.7 mm
Ingress Protection	IP 64 compliant front panel

Table 1-1: Technical Specifications

1.5 Certifications

All IOVU-570M series models comply with the following international standards:

- RoHS
- IP 64

For a more detailed description of these standards, please refer to **Appendix A**.

Chapter

2

Detailed Specifications

2.1 Front Panel

The IOVU-570M front panel (Figure 2-1) comprises a 5.7" TFT WVGA 16-bit color touch screen LCD in an ABS+PC plastic frame.

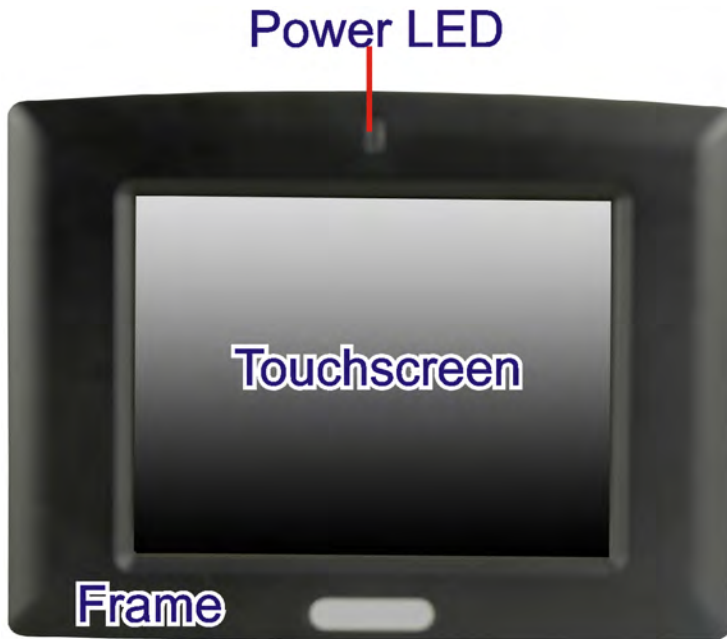

Figure 2-1: Front Panel

2.2 Connector Panel

All external peripheral interface connectors are located on the bottom panel of the IOVU-570M . The peripheral interface connectors are shown in Figure 2-2.

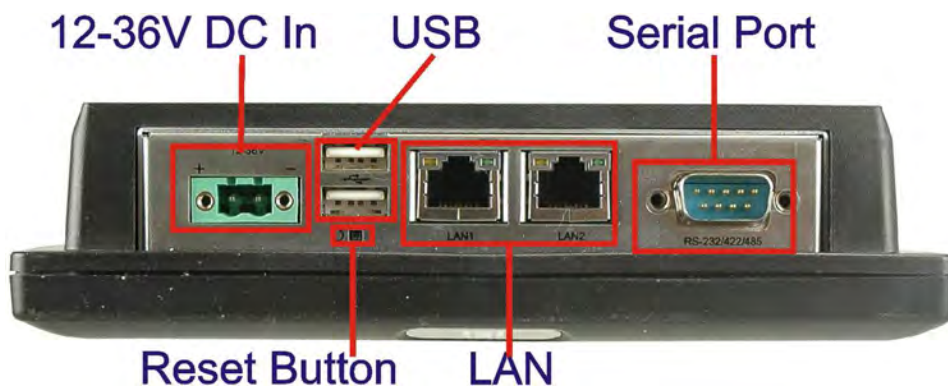

Figure 2-2: IOVU-570M Peripheral Connectors

IOVU-570M Panel PC

External peripheral interface connectors on the IOVU-570M include:

- 1 x DC-IN bare wire terminal block
- 2 x RJ-45 LAN connectors
- 1 x RS-232/422/485 connector
- 2 x USB connectors

2.3 Dimensions

The physical dimensions of the IOVU-570M are shown in Figure 2-3 and listed below:

- Width: 180 mm
- Height: 135.8 mm
- Depth: 46.7 mm

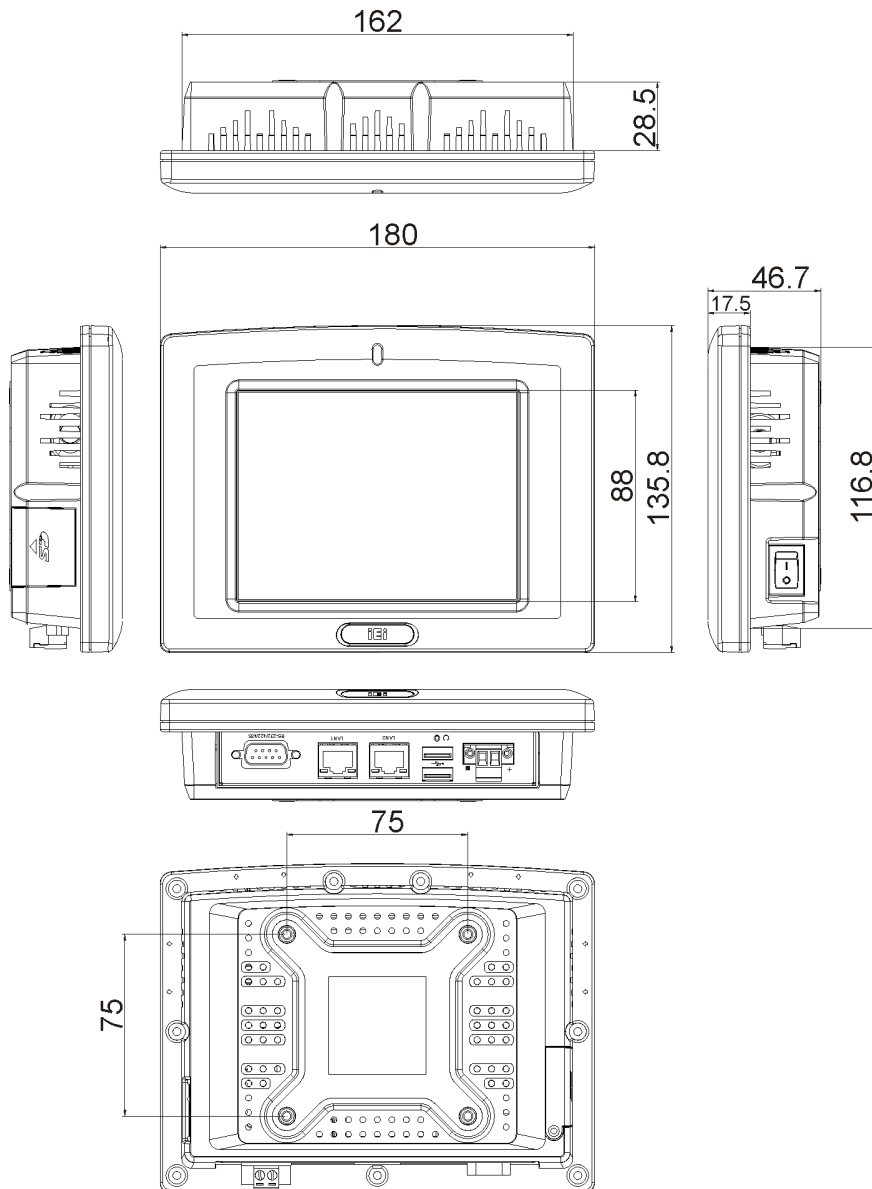

Figure 2-3: IOVU-570M Physical Dimensions (millimeters)

2.4 Power Supply



WARNING:

Whenever you need to remove a part for maintenance or upgrading,
switch off the power supply and unplug the power cord first.

And Risk of explosion if battery is replaced by an incorrect type.

Dispose of used batteries according to the instructions

The IOVU-570M has a terminal block connector on the bottom panel.



Chapter

3

Unpacking

3.1 Anti-static Precautions



WARNING:

Failure to take ESD precautions during installation may result in permanent damage to the IOVU-570M and severe injury to the user.

Electrostatic discharge (ESD) can cause serious damage to electronic components, including the IOVU-570M. Dry climates are especially susceptible to ESD. It is therefore critical that whenever the IOVU-570M or any other electrical component is handled, the following anti-static precautions are strictly adhered to.

- **Wear an anti-static wristband:** Wearing a simple anti-static wristband can help to prevent ESD from damaging the board.
- **Self-grounding:** Before handling the board touch any grounded conducting material. During the time the board is handled, frequently touch any conducting materials that are connected to the ground.
- **Use an anti-static pad:** When configuring the IOVU-570M, place it on an anti-static pad. This reduces the possibility of ESD damaging the IOVU-570M.

3.2 Unpacking Precautions

When the IOVU-570M is unpacked, please do the following:

- Follow the anti-static precautions outlined in **Section 3.1**.
- Make sure the packing box is facing upwards so the IOVU-570M does not fall out of the box.
- Make sure all the components shown in **Section 3.3** are present.

3.3 Unpacking Checklist

NOTE:

If some of the components listed in the checklist below are missing, please do not proceed with the installation. Contact the IEI reseller or vendor you purchased the IOVU-570M from or contact an IEI sales representative directly. To contact an IEI sales representative, please send an email to sales@iei.com.tw.

The IOVU-570M is shipped with the following components:





Quantity	Item and Part Number	Image
1	IOVU-570M	
1	Utility CD including SDK, utilities, and technical documentation	
1	Null modem cable	
1	Touch pen	

Table 3-1: Package List Contents

Chapter

4

Installation

4.1 Installation Precautions

During installation, be aware of the precautions below:

- **Read the user manual:** The user manual provides a complete description of the IOVU-570M, installation instructions and configuration options.
- **DANGER! Disconnect Power:** Power to the IOVU-570M must be disconnected during the installation process, or before any attempt is made to access the rear panel. Electric shock and personal injury might occur if the rear panel of the IOVU-570M is opened while the power cord is still connected to an electrical outlet.
- **Qualified Personnel:** The IOVU-570M must be installed and operated only by trained and qualified personnel. Maintenance, upgrades, or repairs may only be carried out by qualified personnel who are familiar with the associated dangers.
- **Air Circulation:** Make sure there is sufficient air circulation when installing the IOVU-570M. The IOVU-570M's cooling vents must not be obstructed by any objects. Blocking the vents can cause overheating of the IOVU-570M. Leave at least 5 cm of clearance around the IOVU-570M to prevent overheating.
- **Grounding:** The IOVU-570M should be properly grounded. The voltage feeds must not be overloaded. Adjust the cabling and provide external overcharge protection per the electrical values indicated on the label attached to the back of the IOVU-570M.

4.2 SD Card Installation

The IOVU-570M supports a single SD card. To install the SD card, follow the steps below.

Step 1: Undo the SD card cover screw.

Step 2: Slide open the SD card cover.

Step 3: Slide the SD card into the slot. Replace the SD card slot cover and screw.

IOVU-570M Panel PC

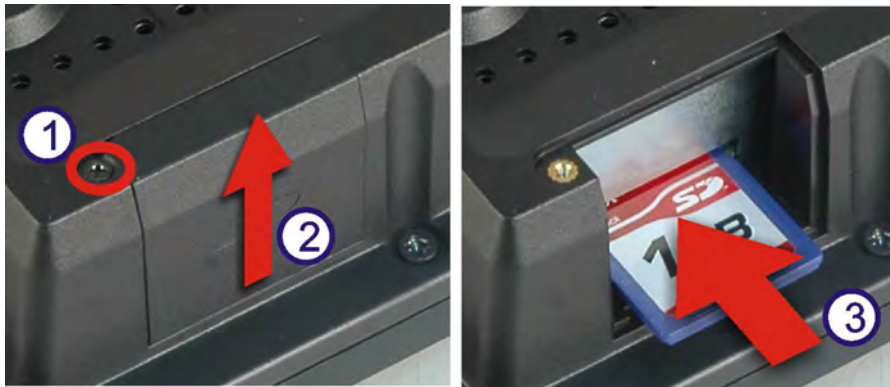

Figure 4-1: SD Card Installation

4.3 External Peripheral Interface Connectors

Table 4-1 lists the external interface connectors on the IOVU-570M. Detailed descriptions of the connectors can be found following the table.

Connector	Type
12-36 V DC bare wire power terminal	Terminal Block
Ethernet connectors	RJ-45 Jack connector
RS-232/422/485 Serial connector	D-sub 9 Male connector
USB connectors	Dual USB port

Table 4-1: External Interface Connectors

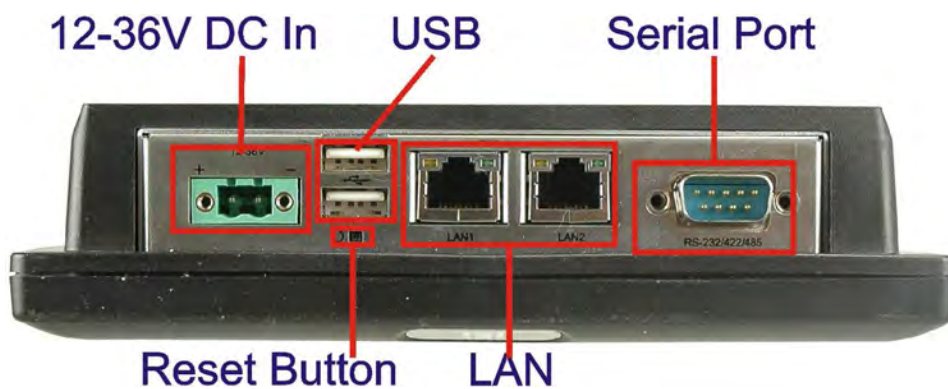

Figure 4-2: IOVU-570M Peripheral Connectors

4.3.1 12 V~36 V DC Terminal Block

The power terminal block connects to a 12 V~36 V DC power source.

- CN Label:** 12-36 V
- CN Type:** Terminal block
- CN Location:** See Figure 4-2
- CN Pinouts:** See Table 4-2 and Figure 4-3

Pin	Description
1	12~36 V DC Power in
2	GND

Table 4-2: 12~36 V Power Connector Pinouts

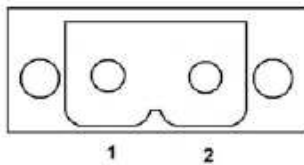

Figure 4-3: Power Terminal Block

4.3.2 RS-232/422/485 Serial Port

This section outlines the usage and setup of the serial port on the rear I/O panel.

4.3.2.1 Connecting the Serial Port

The IOVU-570M has a single female DB-9 connector on the external peripheral interface panel for a serial device. Follow the steps below to connect a serial device to the IOVU-570M.

- Step 1: Insert the serial connector.** Insert the DB-9 connector of a serial device into the DB-9 connector on the external peripheral interface. See Figure 4-4.

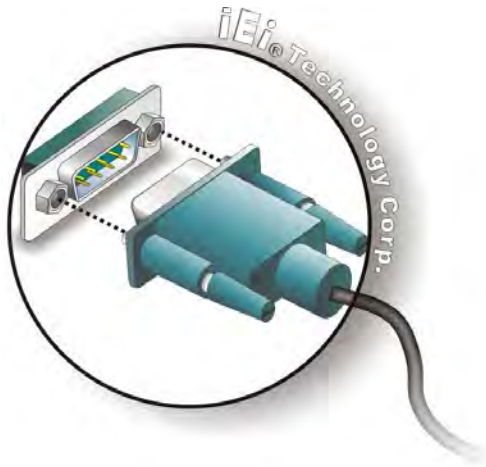

Figure 4-4: Serial Device Connector

Step 2: Secure the connector. Secure the serial device connector to the external interface by tightening the two retention screws on either side of the connector.

4.3.2.2 RS-232/422/485 Selection

To select RS-232, RS-422, or RS-485 mode, please follow the directions below.

Step 1: Select "Start > Programs > IEI > IEI CEUTILITY.exe" to run IEI_CEUTILITY.exe in the "SYSTEM" folder on the SD/CF card).

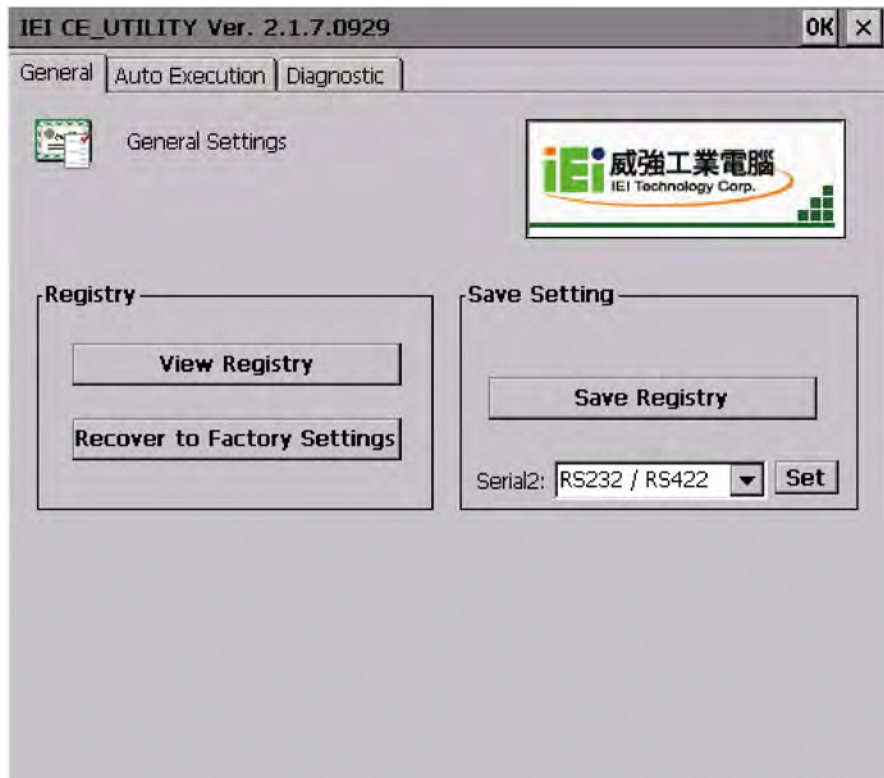

Figure 4-5: Serial Port Mode Setting

- Step 2:** **Change serial port mode setting.** Change the value in Figure 4-5 to the desired mode setting.
- Step 3:** **Click "Set"**
- Step 4:** **Click "Save Registry"** to save the changes.

4.3.2.3 Pinouts

Serial port pinouts are shown below.

Pin	RS-232	RS-422	RS-485
1	DCD	RXD-	DATA-
2	RX	RXD+	DATA+
3	TX	TXD-	
4	DTR		
5	GND	GND	GND

IOVU-570M Panel PC

Pin	RS-232	RS-422	RS-485
6	DSR		
7	RTS	TXD+	
8	CTS		
9	RI		

Table 4-3: Serial Port Pinouts

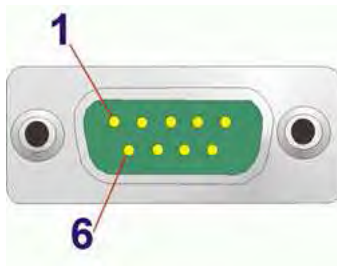

Figure 4-6: Serial Port Pinouts

4.3.3 USB Connectors

The external USB Series "A" receptacle connectors provide easier and quicker access to external USB devices. Follow the steps below to connect USB devices to the IOVU-570M.

- Step 1: Insert a USB Series "A" plug.** Insert the USB Series "A" plug of a device into the USB Series "A" receptacle on the external peripheral interface. See Figure 4-7.

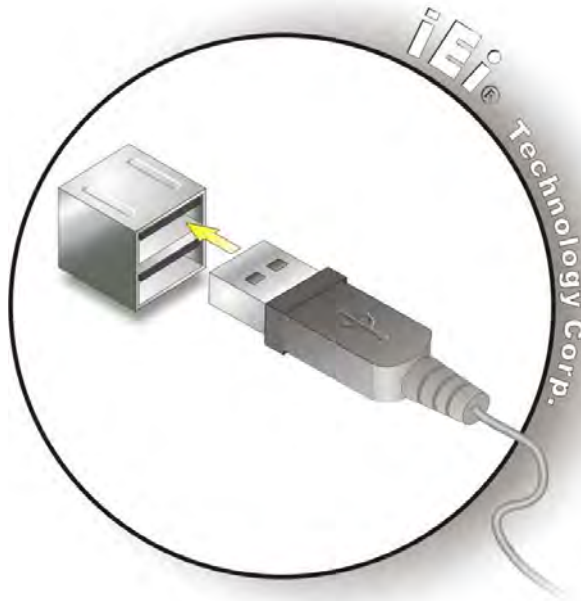

Figure 4-7: USB Connector

USB devices connect directly to the USB connectors on the external peripheral connector panel.

Pin	Description	Pin	Description
1	VCC	5	VCC
2	D1-	6	D2-
3	D1+	7	D2+
4	GND	8	GND

Table 4-4: USB Connector Pinouts

4.3.4 Ethernet Connector

There are two external RJ-45 LAN connectors. The RJ-45 connectors enable connection to an external network. To connect a LAN cable with an RJ-45 connector, please follow the instructions below.

Step 1: Align the connectors. Align the RJ-45 connector on the LAN cable with one of the RJ-45 connectors on the IOVU-570M. See Figure 4-8.

IOVU-570M Panel PC

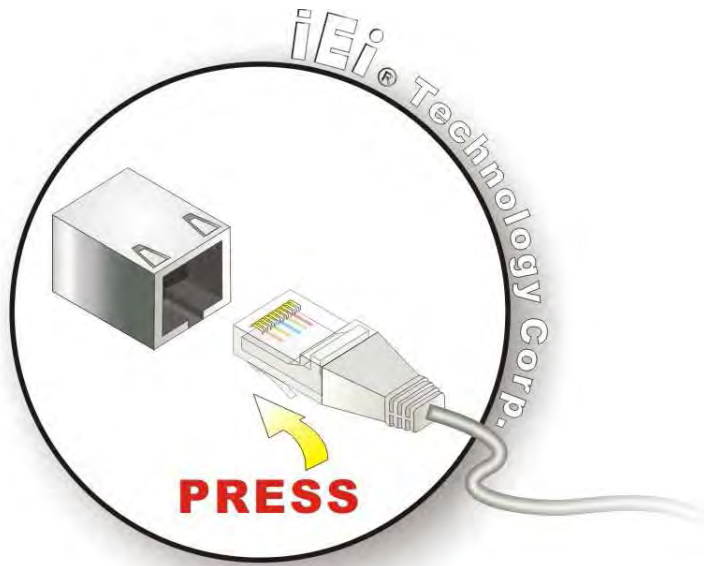

Figure 4-8: LAN Connection

Step 2: Insert the LAN cable RJ-45 connector. Once aligned, gently insert the LAN cable RJ-45 connector into the on-board RJ-45 connector.

The Ethernet connector pinouts are shown below.

PIN	DESCRIPTION
1	TPT+
2	TPT-
3	TPR+
4	LAN_GND
5	LAN_GND
6	TPR-
7	LAN_GND
8	LAN_GND

Table 4-5: Ethernet Connector Pinouts



Figure 4-9: Ethernet Connector

The RJ-45 Ethernet connector has two status LEDs, one green and one yellow. The green LED indicates activity on the port and the yellow LED indicates the port is linked (Table 4-6).

SPEED LED		LINK LED	
Status	Description	Status	Description
GREEN	ON: 100 MB OFF: 10 MB	YELLOW	ON: Linked Flashing: Activity

Table 4-6: Ethernet Connector LEDs

4.4 Mounting the System



WARNING!

When mounting the flat panel PC onto an arm, onto the wall or onto a panel, it is better to have more than one person to help with the installation to make sure the panel PC does not fall down and get damaged.

Three methods of mounting the IOVU-570M are listed below.

- Wall mounting

The mounting methods are described below.

4.4.1 Wall Mounting

To mount the IOVU-570M onto the wall, please follow the steps below.

IOVU-570M Panel PC

- Step 1:** Select the location on the wall for the wall-mounting bracket.
- Step 2:** Carefully mark the locations of the four screw holes in the bracket on the wall.
- Step 3:** Drill four pilot holes at the marked locations on the wall for the bracket retention screws.
- Step 4:** Align the wall-mounting bracket screw holes with the pilot holes.
- Step 5:** Secure the mounting-bracket to the wall by inserting the retention screws into the four pilot holes and tightening them (Figure 4-10).

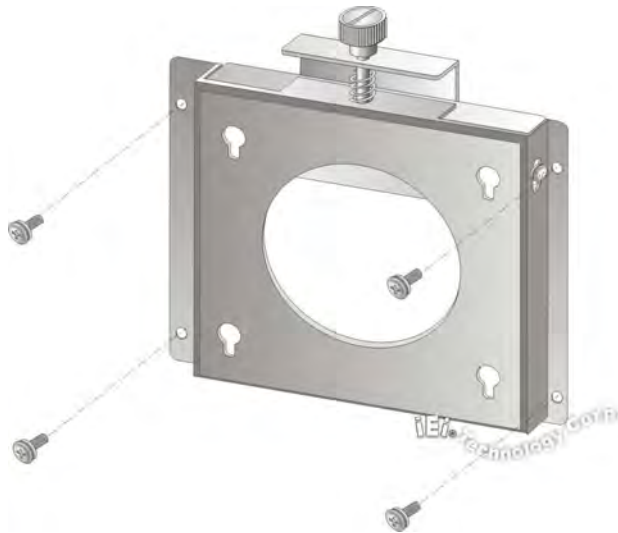

Figure 4-10: Wall-mounting Bracket

- Step 6:** Insert the four monitor mounting screws provided in the wall mounting kit into the four screw holes on the rear panel of the IOVU-570M and tighten until the screw shank is secured against the rear panel (Figure 4-11).
- Step 7:** Align the mounting screws on the monitor rear panel with the mounting holes on the bracket.
- Step 8:** Carefully insert the screws through the holes and gently pull the monitor downwards until the monitor rests securely in the slotted holes (Figure 4-11). Ensure that all four of the mounting screws fit snugly into their respective slotted holes.



NOTE:

In the diagram below the bracket is already installed on the wall.

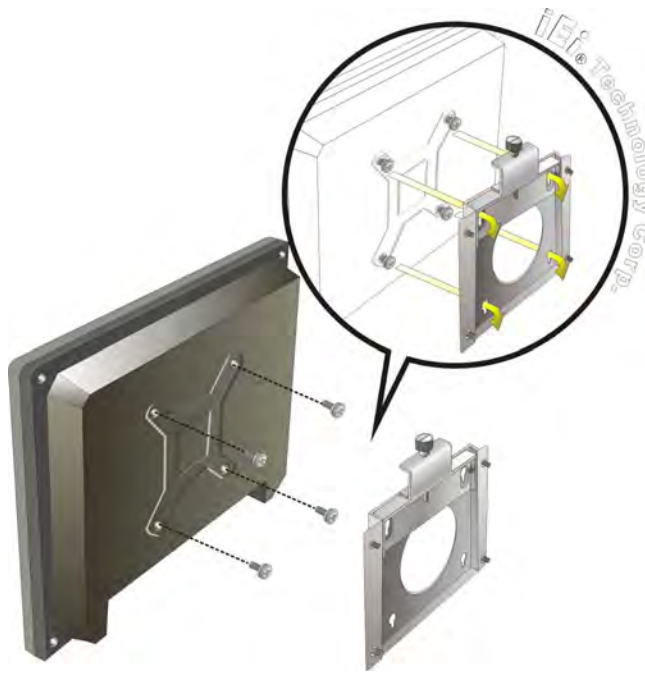

Figure 4-11: Chassis Support Screws

Step 9: Secure the panel PC by fastening the retention screw of the wall-mounting bracket. (Figure 4-12).

IOVU-570M Panel PC

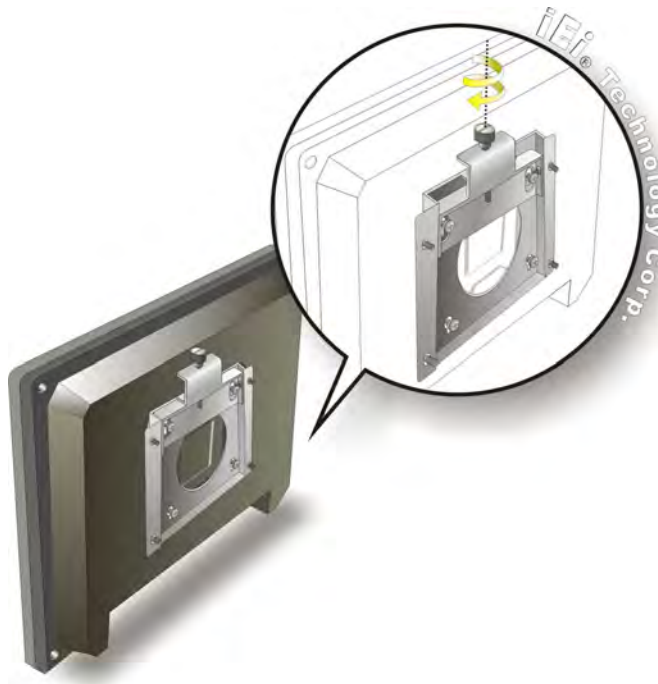

Figure 4-12: Secure the IOVU-570M

4.5 Software

The IOVU-570M comes with a pre-installed Windows CE 5.0 or Linux 2.6.x operating system and a rich software application development kit. For information about configuring the operating system, adding remote management tools or additional software and drivers, refer to the user manuals on IEI IOVU Utility CD that came with the IOVU-570M. The IOVU includes the following software:

- Standard Windows® CE5.0 professional version license.
- Optional Board Support Package (BSP) for customers to customize their own OS image.
- Attached Software Development Kit (SDK) for embedded Visual C++ to program Windows CE application.
- Built-in .NET Compact Framework support with related SDK
- Thin Client Technology, Microsoft RDP (Remote Desktop Protocol), to enable IOVU-570M to access Microsoft Windows® based applications installed on Microsoft Terminal Service server.
- Free pre-installed utilities for configuring and diagnosing your IOVU-570M.

- Free remote management tools installed in laptop for remotely configuring, monitoring, and managing your IOVU-570M.

4.5.1 Wireless AP

To select Wireless AP, please follow the instructions below.

Step 1: When turn on the power, Wireless AP start to search wireless base stations around as shown below. (Figure 4-13).

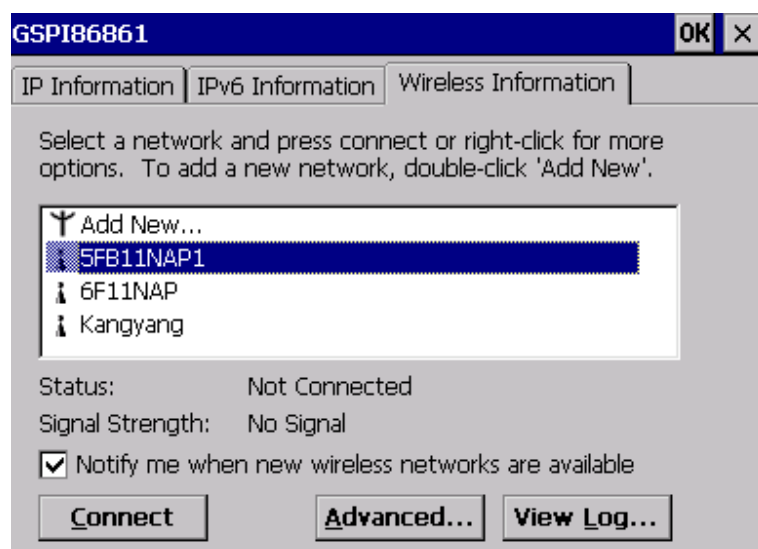

Figure 4-13: Wireless AP

Step 2: Select your Internet connection and click Connect.

Step 3: The Wireless Network Properties screen appears next. (Figure 4-14).

IOVU-570M Panel PC

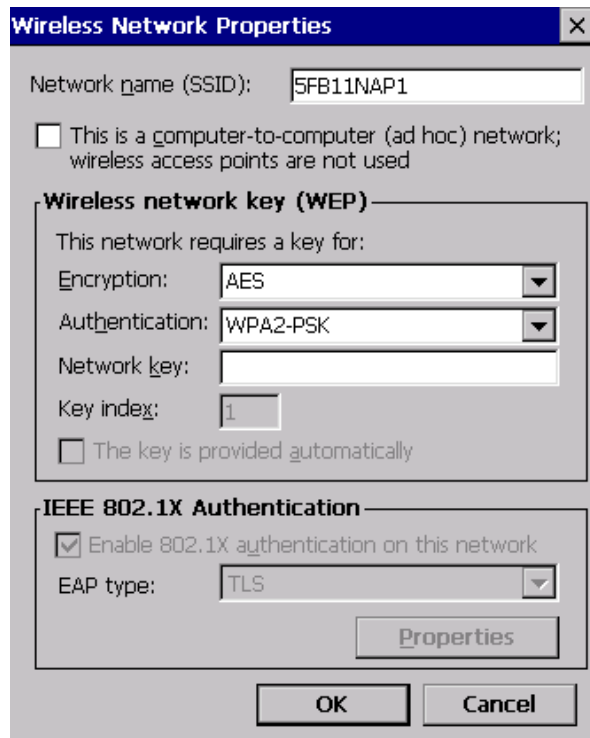

Figure 4-14: Wireless Network Properties

Step 4: You must input the password into the Network key. Click OK. The soft AP configuration is finished. (Figure 4-15).

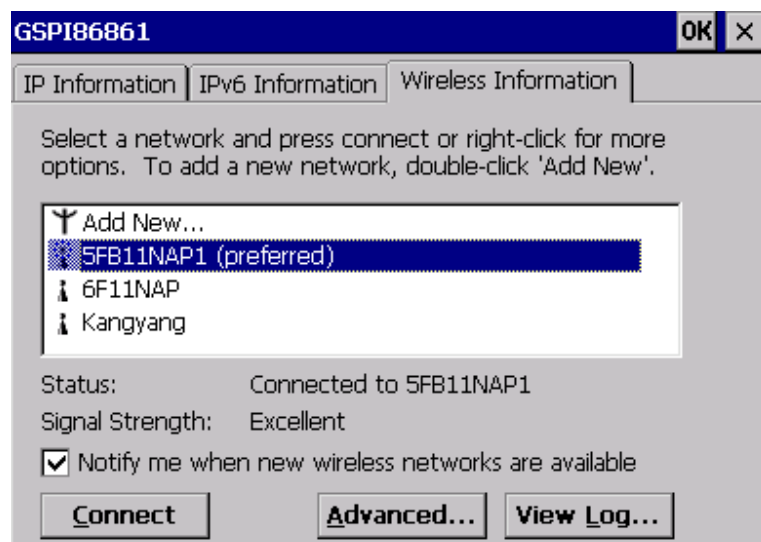

Figure 4-15: Wireless AP Connected

Step 5: Click the IP Information button to view the information of the Wireless AP Solo.If the server function is enabled on the AP. You can automatically get the IP address, subnet mask. (Figure 4-16).

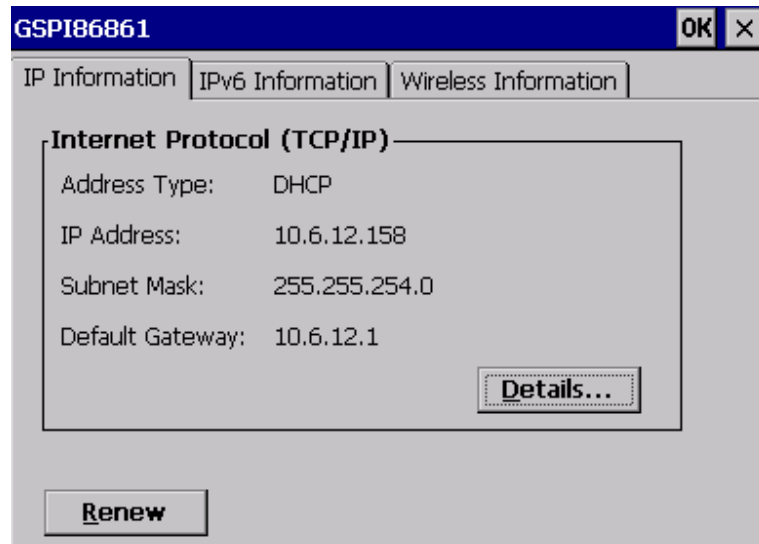

Figure 4-16: IP Information

Appendix

A

Certifications

A.1 RoHS Compliant

All models in the IOVU series comply with the Restriction of Hazardous Materials (RoHS) Directive. This means that all components used to build the industrial workstations and the workstation itself are RoHS compliant.

The RoHS Directive bans the placing on the EU market of new electrical and electronic equipment containing more than agreed levels of lead, cadmium, mercury, hexavalent chromium, polybrominated biphenyl (PBB) and polybrominated diphenyl ether (PBDE) flame retardants.

A.2 IP 64 Compliant Front Panel

The front panels on all models in the IOVU series have an ingress protection rating (IP) of 64, IP 64 or greater. The front panels are protected from dust particles and splashed water.

Appendix

B

Safety Precautions

B.1 Safety Precautions



WARNING:

The precautions outlined in this appendix should be strictly followed. Failure to follow these precautions may result in permanent damage to the IOVU-570M.

Please follow the safety precautions outlined in the sections that follow:

B.1.1 General Safety Precautions

Please ensure the following safety precautions are adhered to at all times.

- ***Make sure the power is turned off and the power cord is disconnected*** whenever the IOVU-570M is being installed, moved or modified.
- ***Do not apply voltage levels that exceed the specified voltage range.*** Doing so may cause fire and/or an electrical shock.
- ***Electric shocks can occur*** if the IOVU-570M chassis is opened when the IOVU-570M is running.
- ***Do not drop or insert any objects*** into the ventilation openings of the IOVU-570M.
- ***If considerable amounts of dust, water, or fluids enter the IOVU-570M,*** turn off the power supply immediately, unplug the power cord, and contact the IOVU-570M vendor.
- **DO NOT:**
 - Drop the IOVU-570M against a hard surface.
 - Strike or exert excessive force onto the LCD panel.
 - Touch any of the LCD panels with a sharp object
 - In a site where the ambient temperature exceeds the rated temperature

IOVU-570M Panel PC

B.1.2 Anti-static Precautions



WARNING:

Failure to take ESD precautions during the installation of the IOVU-570M may result in permanent damage to the IOVU-570M and severe injury to the user.

Electrostatic discharge (ESD) can cause serious damage to electronic components, including the IOVU-570M. Dry climates are especially susceptible to ESD. It is therefore critical that whenever the IOVU-570M is opened and any of the electrical components are handled, the following anti-static precautions are strictly adhered to.

- ***Wear an anti-static wristband:*** Wearing a simple anti-static wristband can help to prevent ESD from damaging any electrical component.
- ***Self-grounding:*** Before handling any electrical component, touch any grounded conducting material. During the time the electrical component is handled, frequently touch any conducting materials that are connected to the ground.
- ***Use an anti-static pad:*** When configuring or working with an electrical component, place it on an anti-static pad. This reduces the possibility of ESD damage.
- ***Only handle the edges of the electrical component:*** When handling the electrical component, hold the electrical component by its edges.

B.2 Maintenance and Cleaning Precautions

When maintaining or cleaning the IOVU-570M, please follow the guidelines below.

B.2.1 Maintenance and Cleaning

Prior to cleaning any part or component of the IOVU-570M, please read the details below.

- Except for the LCD panel, never spray or squirt liquids directly onto any other components. To clean the LCD panel, gently wipe it with a piece of soft dry cloth or a slightly moistened cloth.

- The interior of the IOVU-570M does not require cleaning. Keep fluids away from the IOVU-570M interior.
- Be cautious of all small removable components when vacuuming the IOVU-570M.
- Turn the IOVU-570M off before cleaning the IOVU-570M.
- Never drop any objects or liquids through the openings of the IOVU-570M.
- Be cautious of any possible allergic reactions to solvents or chemicals used when cleaning the IOVU-570M.
- Avoid eating, drinking and smoking within vicinity of the IOVU-570M.

B.2.2 Cleaning Tools

Some components in the IOVU-570M may only be cleaned using a product specifically designed for the purpose. In such case, the product will be explicitly mentioned in the cleaning tips. Below is a list of items to use when cleaning the IOVU-570M.

- **Cloth** – Although paper towels or tissues can be used, a soft, clean piece of cloth is recommended when cleaning the IOVU-570M.
- **Water or rubbing alcohol** – A cloth moistened with water or rubbing alcohol can be used to clean the IOVU-570M.
- **Using solvents** – The use of solvents is not recommended when cleaning the IOVU-570M as they may damage the plastic parts.
- **Vacuum cleaner** – Using a vacuum specifically designed for computers is one of the best methods of cleaning the IOVU-570M. Dust and dirt can restrict the airflow in the IOVU-570M and cause its circuitry to corrode.
- **Cotton swabs** - Cotton swabs moistened with rubbing alcohol or water are excellent tools for wiping hard to reach areas.
- **Foam swabs** - Whenever possible, it is best to use lint free swabs such as foam swabs for cleaning.

B.3 FCC Precautions

**WARNING:**

This equipment has been tested and found to comply with the limits for a Class A digital device, pursuant to Part 15 of the FCC Rules. These limits are designed to provide reasonable protection against harmful interference in a residential installation. This equipment generates, uses and can radiate radio frequency energy and, if not installed and used in accordance with the instructions, may cause harmful interference to radio communications. However, there is no guarantee that interference will not occur in a particular installation. If this equipment does cause harmful interference to radio or television reception, which can be determined by turning the equipment off and on, the user is encouraged to try to correct the interference by one or more of the following measures:

- Reorient or relocate the receiving antenna.
- Increase the separation between the equipment and receiver.
- Connect the equipment into an outlet on a circuit different from that to which the receiver is connected.
- Consult the dealer or an experienced radio/TV technician for help.

FCC Caution: Any changes or modifications not expressly approved by the party responsible for compliance could void the user's authority to operate this equipment.

This device and its antenna(s) must not be co-located or operating in conjunction with any other antenna or transmitter.

IMPORTANT NOTE: FCC Radiation Exposure Statement: This equipment complies with FCC radiation exposure limits set forth for an uncontrolled environment. This equipment should be installed and operated with minimum distance 20cm between the radiator & your body.

For product available in the USA/Canada market, only channel 1~11 can be operated. Selection of other channels is not possible.

This device complies with Part 15 of the FCC Rules. Operation is subject to the following two conditions: (1) This device may not cause harmful interference, and (2) this device must accept any interference received, including interference that may cause undesired operation.



Appendix

C

Hazardous Materials Disclosure

C.1 Hazardous Materials Disclosure Table for IPB Products Certified as RoHS Compliant Under 2002/95/EC Without Mercury

The details provided in this appendix are to ensure that the product is compliant with the Peoples Republic of China (China) RoHS standards. The table below acknowledges the presences of small quantities of certain materials in the product, and is applicable to China RoHS only.

A label will be placed on each product to indicate the estimated “Environmentally Friendly Use Period” (EFUP). This is an estimate of the number of years that these substances would “not leak out or undergo abrupt change.” This product may contain replaceable sub-assemblies/components which have a shorter EFUP such as batteries and lamps. These components will be separately marked.

Please refer to the table on the next page.

Part Name	Toxic or Hazardous Substances and Elements					
	Lead (Pb)	Mercury (Hg)	Cadmium (Cd)	Hexavalent Chromium (CR(VI))	Polybrominated Biphenyls (PBB)	Polybrominated Diphenyl Ethers (PBDE)
Housing	X	O	O	O	O	X
Display	X	O	O	O	O	X
Printed Circuit Board	X	O	O	O	O	X
Metal Fasteners	X	O	O	O	O	O
Cable Assembly	X	O	O	O	O	X
Fan Assembly	X	O	O	O	O	X
Power Supply Assemblies	X	O	O	O	O	X
Battery	O	O	O	O	O	O

O: This toxic or hazardous substance is contained in all of the homogeneous materials for the part is below the limit requirement in SJ/T11363-2006

X: This toxic or hazardous substance is contained in at least one of the homogeneous materials for this part is above the limit requirement in SJ/T11363-2006

IOVU-570M Panel PC

此附件旨在确保本产品符合中国 RoHS 标准。以下表格标示此产品中某有毒物质的含量符合中国 RoHS 标准规定的限量要求。

本产品上会附有“环境友好使用期限”的标签，此期限是估算这些物质“不会有泄漏或突变”的年限。本产品可能包含有较短的环境友好使用期限的可替换元件，像是电池或灯管，这些元件将会单独标示出来。

部件名称	有毒有害物质或元素					
	铅 (Pb)	汞 (Hg)	镉 (Cd)	六价铬 (CR(VI))	多溴联苯 (PBB)	多溴二苯 醚 (PBDE)
壳体	X	O	O	O	O	X
显示	X	O	O	O	O	X
印刷电路板	X	O	O	O	O	X
金属螺帽	X	O	O	O	O	O
电缆组装	X	O	O	O	O	X
风扇组装	X	O	O	O	O	X
电力供应组装	X	O	O	O	O	X
电池	O	O	O	O	O	O

O: 表示该有毒有害物质在该部件所有物质材料中的含量均在 SJ/T11363-2006 标准规定的限量要求以下。
X: 表示该有毒有害物质至少在该部件的某一均质材料中的含量超出 SJ/T11363-2006 标准规定的限量要求。