



IEI Technology Corp.



MODEL:
TUS3400

User Manual

Rev. 1.01 – 15 March, 2017





Revision

Date	Version	Changes
17 September, 2013	1.00	Initial release
11 November, 2016	1.01	USB port update

Copyright

COPYRIGHT NOTICE

The information in this document is subject to change without prior notice in order to improve reliability, design and function and does not represent a commitment on the part of the manufacturer.

In no event will the manufacturer be liable for direct, indirect, special, incidental, or consequential damages arising out of the use or inability to use the product or documentation, even if advised of the possibility of such damages.

This document contains proprietary information protected by copyright. All rights are reserved. No part of this manual may be reproduced by any mechanical, electronic, or other means in any form without prior written permission of the manufacturer.

TRADEMARKS

All registered trademarks and product names mentioned herein are used for identification purposes only and may be trademarks and/or registered trademarks of their respective owners.

Table of Contents

1. INTRODUCTION.....	5
1.1 OVERVIEW.....	6
1.2 DIMENSIONS.....	7
1.3 SPECIFICATIONS.....	9
2 UNPACKING.....	11
2.1 UNPACKING.....	12
2.2 PACKING LIST.....	13
3 INSTALLATION	14
3.1 ANTI-STATIC PRECAUTIONS.....	15
3.2 INSTALLATION PRECAUTIONS.....	15
3.3 PREINSTALLED COMPONENTS.....	16
3.4 REMOVING THE BACK COVER.....	17
3.5 REMOVING THE CONSOLE.....	18
4 SYSTEM MAINTENANCE.....	19
4.1 SYSTEM MAINTENANCE INTRODUCTION.....	20
4.2 MOTHERBOARD REPLACEMENT.....	20
4.3 BACK COVER REMOVAL.....	20
4.4 CONSOLE REPLACEMENT.....	21
4.5 SO-DIMM REPLACEMENT.....	21
5 SAFETY PRECAUTIONS.....	23
A.1 SAFETY PRECAUTIONS.....	24
A.1.1 General Safety Precautions.....	24
A.1.2 Anti-static Precautions.....	25
A.1.3 Product Disposal	26
A.2 MAINTENANCE AND CLEANING PRECAUTIONS.....	26
A.2.1 Maintenance and Cleaning.....	26
A.2.2 Cleaning Tools.....	27
A.2.3 Federal Communication Commission Interference Statement.....	28
6 HAZARDOUS MATERIALS DISCLOSURE.....	29
B.1 HAZARDOUS MATERIAL DISCLOSURE TABLE FOR IPB PRODUCTS CERTIFIED AS ROHS COMPLIANT UNDER 2002/95/EC WITHOUT MERCURY.....	30

Chapter

1

Introduction

1.1 Overview

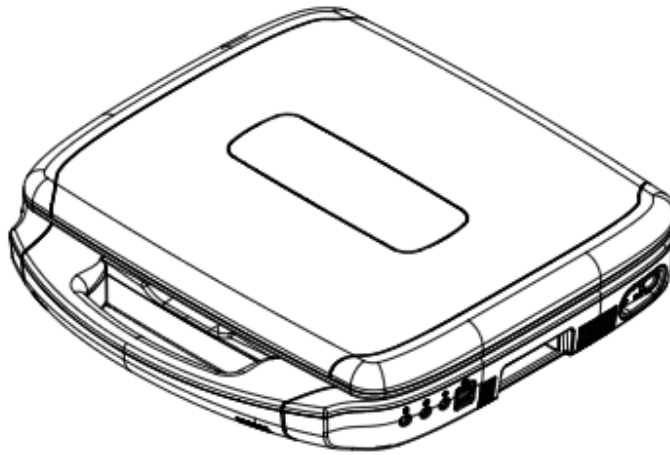

Figure 1-1: TUS3400 Portable Computer

The TUS3400 portable computer provides all the features of a PC. The TUS3400 provides wireless networking for integration into company/facility networks. The major external device connections include USB 3.0/2.0 and serial port connectors. Storage options include a 2.5" hard drive, allowing for flexibility in choosing solid state drives or traditional hard drives. 2 HDMI outputs on the left side allow the TUS3400 to connect to a second/third screen for duplicating the screen contents or extending the user interface.

TUS3400

1.2 Dimensions



{ISOMETRIC FRONT}

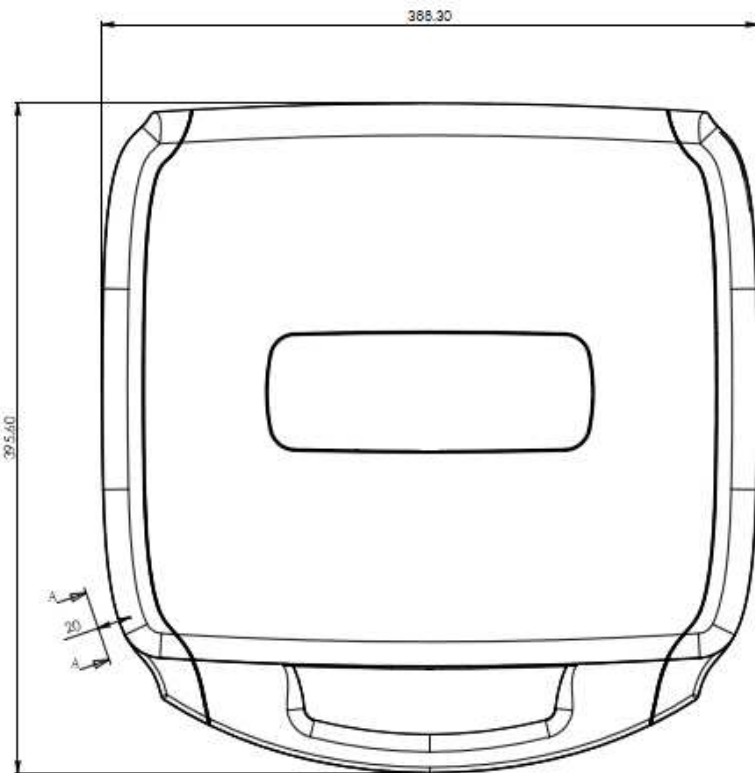

{FRONT}

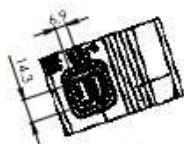

SECTION A-A
Scale 1:1.5

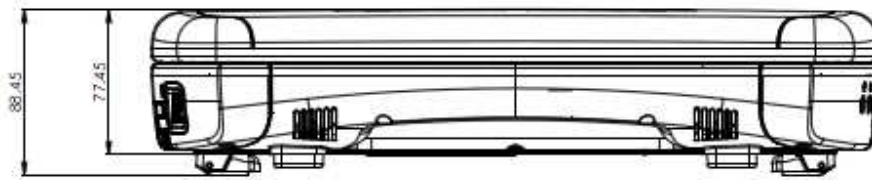

{BOTTOM}

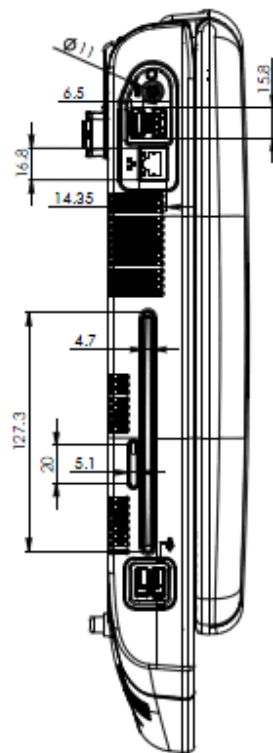

{LEFT}

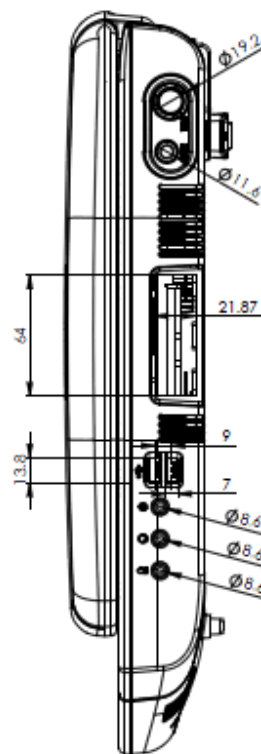

{RIGHT}

TUS3400 Dimensions (mm)

TUS3400

1.3 Specifications

The technical specifications for the TUS3400 system are listed in below table.

Model Name		TUS3400
MB	SBC Model	TRN-HM65-MB
	CPU	2nd Generation Intel® Core™i7-3555LE processor
	Chipset	Intel HM65
	RAM	2 x 4G DDR3 1333 SO-DIMM (Support ECC)
Display	LCD Size	15"
	Max Resolution	1024x768
	Brightness (cd/m2)	minimum of 300 nits
	Contrast Ratio	500:1
	LCD Color	16.2M
	Pixel Pitch (mm)	0.297(H) x 0.297(V)
	Viewing Angle (H-V)	170(H)/ 170(V)
I/O Port		1x Power DC-JACK Connector
		1x RJ-45 Connector For LAN
		2x USB3.0 port, 2x USB2.0 port
		2 x HDMI connector
		1xExt Power Switch connector
		1xLine in Jack connector
		1x Line out Jack connector
LED	Sleep LED	Blue
	Charging LED	Bi-color, blue or amber. It is amber when charging, and blue when fully charged and the power adapter is connected.
Storage		1 x 2.5" 1T HDD
Main Module	DVD	1 x Slot-in DVD, 8x SuperDrive DVD +/- R DL/DVD +/-RW, CD- RW
	WiFi	1 x Wireless LAN 802.11a/b/g/n module by internal Mini PCIe interface
	Speaker	2 x stereo speakers + 1 x sub-woofer (internal speaker)
	Console	1 x Keyboard/Trackball Console
	Camera module	Up to UXGA resolution (1600X1200) to take still image, support VGA (640x480) resolution up to 30fps at YUY2 mode

Physical	Construction Material	PC+ABS
	Dimension (WxHxD)	388.3*395.6*88.45 (mm)
	Weight	6.8kg
	Magnetic Latch	a. Magnet size: 30mm x 8mm x 6mm. b. Q'ty : 8pcs (B part*4, C part *4) c. Open/Close Force : 2.0kgf ~ 2.5kgf.
Environment	Operation Temperature	0~35℃
	Storage Temperature	0~60℃
Power	Battery	SANYO UR18650FK, 11.1V, 5400mah, 3S2P=59.94WH
	Power Supply	Power adapter: medical grade AC/DC adapter, Output: 19 VDC
OS		Windows 7 32bit
Others	Logo	Terason, illuminated logo
	Flip-down feet	

Chapter

2

Unpacking

2.1 Unpacking

To unpack the Portable Computer, follow the steps below:



WARNING!

The front side LCD screen has a protective plastic cover stuck to the screen. Only remove the plastic cover after the panel PC has been properly installed. This ensures the screen is protected during the installation process.

- Step 1:** Use box cutters, a knife or a sharp pair of scissors that seals the top side of the external (second) box.
- Step 2:** Open the external (second) box.
- Step 3:** Use box cutters, a knife or a sharp pair of scissors that seals the top side of the internal (first) box.
- Step 4:** Lift the monitor out of the boxes.
- Step 5:** Remove both polystyrene ends, one from each side.
- Step 6:** Pull the plastic cover off the portable computer.
- Step 7:** Make sure all the components listed in the packing list are present.

TUS3400

2.2 Packing List

The TUS3400 is shipped with the following components:

Quantity	Item	Remark
1	TUS3400	
1	Power Adapter (P/N: TRN-63040-010120-020-RS)	

Packing List

If any of the above items are missing or damaged, contact the distributor or sales representative immediately.



Chapter

3

Installation

3.1 Anti-static Precautions



WARNING:

Failure to take ESD precautions during the maintenance may result in permanent damage to the system and severe injury to the user.

Electrostatic discharge (ESD) can cause serious damage to electronic components, including the TUS3400. Dry climates are especially susceptible to ESD. It is therefore critical that whenever the TUS3400 is accessed internally, or any other electrical component is handled, the following anti-static precautions are strictly adhered to.

- ***Wear an anti-static wristband:*** - Wearing a simple anti-static wristband can help to prevent ESD from damaging the board.
- ***Self-grounding:*** - Before handling the board touch any grounded conducting material. During the time the board is handled, frequently touch any conducting materials that are connected to the ground.
- ***Use an anti-static pad:*** - When configuring the TUS3400, place it on an anti-static pad. This reduces the possibility of ESD damaging the TUS3400.
- ***Only handle the edges of the PCB:*** - When handling the PCB, hold the PCB by the edges.

3.2 Installation Precautions

When installing the portable computer, please follow the precautions listed below:

- **Power turned off:** When installing the portable computer, make sure the power is off. Failing to turn off the power may cause severe injury to the body and/or damage to the system.
- **Certified Engineers:** Only certified engineers should install and modify onboard functionalities.

- **Anti-static Discharge:** If a user open the portable computer to configure the jumpers or plug in added peripheral devices, ground themselves first and wear an anti-static wristband.

3.3 Preinstalled Components

The following components are all preinstalled.

- **Motherboard**
- **DDR3 memory module**
- **TFT LCD**
- **System cooling fans**
- **CPU**
- **HDD**
- **Wi-Fi module**
- **Optical disk drive**

TUS3400

3.4 Removing the Back Cover

Remove all the retention screws on the back cover. Lift the cover up to remove.



3.5 Removing the Console

Remove all the retention screws on the chassis base. Lift the console up to remove.



Chapter

4

System Maintenance

4.1 System Maintenance Introduction

The following system components may require maintenance.

- Motherboard
- SO-DIMM module
- Wifi module
- Cooling fans
- HDD

If these components fail, they must be replaced. Please contact the system reseller or vendor to purchase replacement parts. Replacement instructions for the above listed components are described below.

4.2 Motherboard Replacement

A user cannot replace a motherboard. If the motherboard fails it must be shipped back to IEI to be replaced. If the system motherboard has failed, please contact the system vendor, reseller or an IEI sales person directly.

4.3 Back Cover Removal



WARNING!

Before removing the back cover, make sure all power to the system has been disconnected. Failing to do so may cause severe damage to the TUS3400 and injury to the user.

To access the HDD and install ECG, ultrasound module, the back cover must be removed. To remove the back cover, please refer to Section 4 for removal instructions.

4.4 Console Removal



WARNING!

Before removing the console, make sure all power to the system has been disconnected. Failing to do so may cause severe damage to the TUS3400 and injury to the user.



WARNING!

Please take antistatic precautions when working with the internal components. The interior of the TUS3400 contains very sensitive electronic components. These components are easily damaged by electrostatic discharge (ESD). Before working with the internal components, make sure all anti-static precautions described earlier have been observed.

To access the portable computer internal components, the console must be removed. To remove the console, please refer to Section 3.5 for console removal instructions.

4.5 SO-DIMM Replacement

Please read the warnings at the beginning of the previous section before attempting to access any TUS3400 internal components.

To install/replace the SO-DIMM modules, please follow the steps below.

- Step 1:** Remove the Console (Section 3.5).
- Step 2:** Locate the SO-DIMM module on the motherboard.
- Step 3:** Release the SO-DIMM module by pulling both the spring retainer clips outward from the socket.

- Step 4:** Grasp the SO-DIMM module by the edges and carefully pull it out of the socket.
- Step 5:** Install the new SO-DIMM module by pushing it into the socket at an angle (Figure 4-1).
- Step 6:** Gently push the rear of the SO-DIMM module down (Figure 4-1). The spring retainer clips clip into place and secure the SO-DIMM module in the socket.

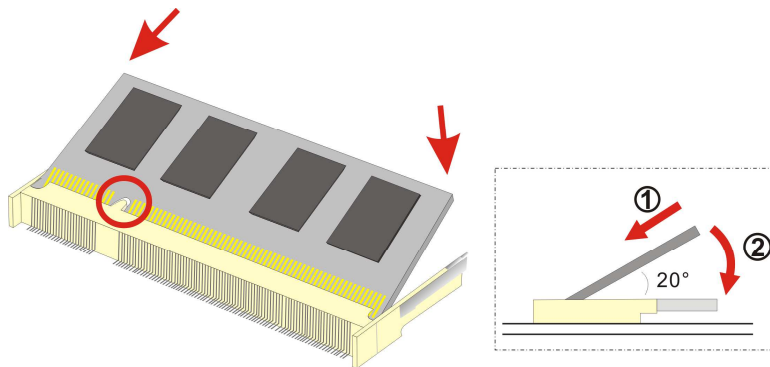

Figure 4-1: SO-DIMM Module Installation

- Step 7:** Push the new DIMM module until it engages and the white plastic end clips

Chapter

5

Safety Precautions

**WARNING:**

The precautions outlined in this chapter should be strictly followed. Failure to follow these precautions may result in permanent damage to the system.

A.1 Safety Precautions

Please follow the safety precautions outlined in the sections that follow:

A.1.1 General Safety Precautions

Please ensure the following safety precautions are adhered to at all times.

- *Follow the electrostatic precautions* outlined below whenever the EP series is opened.
- *Make sure the power is turned off and the power cord is disconnected* whenever the EP series is being installed, moved or modified.
- *Do not apply voltage levels that exceed the specified voltage range.* Doing so may cause fire and/or an electrical shock.
- *Electric shocks can occur* if the chassis is opened when the system is running.
- *Do not drop or insert any objects* into the ventilation openings of the portable computer
- *If considerable amounts of dust, water, or fluids enter the portable computer,* turn off the power supply immediately, unplug the power cord, and contact the system vendor.
- **DO NOT:**
 - Drop the portable computer against a hard surface.
 - Strike or exert excessive force onto the LCD panel.
 - Touch any of the LCD panels with a sharp object
 - In a site where the ambient temperature exceeds the rated temperature

A.1.2 Anti-static Precautions



WARNING:

Failure to take ESD precautions during the installation of the system may result in permanent damage to the system and severe injury to the user.

Electrostatic discharge (ESD) can cause serious damage to electronic components, including the TUS3400. Dry climates are especially susceptible to ESD. It is therefore critical that whenever the TUS3400 is opened and any of the electrical components are handled, the following anti-static precautions are strictly adhered to.

- ***Wear an anti-static wristband:*** Wearing a simple anti-static wristband can help to prevent ESD from damaging any electrical component.
- ***Self-grounding:*** Before handling any electrical component, touch any grounded conducting material. During the time the electrical component is handled, frequently touch any conducting materials that are connected to the ground.
- ***Use an anti-static pad:*** When configuring or working with an electrical component, place it on an anti-static pad. This reduces the possibility of ESD damage.
- ***Only handle the edges of the electrical component:*** When handling the electrical component, hold the electrical component by its edges.

A.1.3 Product Disposal



CAUTION:

Risk of explosion if battery is replaced by and incorrect type. Only certified engineers should replace the on-board battery.

Dispose of used batteries according to instructions and local regulations.

- Outside the European Union - If you wish to dispose of used electrical and electronic products outside the European Union, please contact your local authority so as to comply with the correct disposal method.
- Within the European Union:

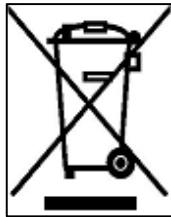

EU-wide legislation, as implemented in each Member State, requires that waste electrical and electronic products carrying the mark (left) must be disposed of separately from normal household waste. This includes monitors and electrical accessories, such as signal cables or power cords. When you need to dispose of your display products, please follow the guidance of your local authority, or ask the shop where you purchased the product. The mark on electrical and electronic products only applies to the current European Union Member States.

Please follow the national guidelines for electrical and electronic product disposal.

A.2 Maintenance and Cleaning Precautions

When maintaining or cleaning the TUS3400, please follow the guidelines below.

A.2.1 Maintenance and Cleaning

Prior to cleaning any part or component of the TUS3400, please read the details below.

- Except for the LCD panel, never spray or squirt liquids directly onto any

- other components. To clean the LCD panel, gently wipe it with a piece of soft dry cloth or a slightly moistened cloth.
- The interior of the TUS3400 does not require cleaning. Keep fluids away from the EP series interior.
 - Be cautious of all small removable components when vacuuming the TUS3400.
 - Turn the TUS3400 off before cleaning it.
 - Never drop any objects or liquids through the openings of the TUS3400.
 - Be cautious of any possible allergic reactions to solvents or chemicals used when cleaning the TUS3400.
 - Avoid eating, drinking and smoking within vicinity of the TUS3400.

A.2.2 Cleaning Tools

Some components in the TUS3400 may only be cleaned using a product specifically designed for the purpose. In such case, the product will be explicitly mentioned in the cleaning tips. Below is a list of items to use when cleaning the TUS3400.

- *Cloth* – Although paper towels or tissues can be used, a soft, clean piece of cloth is recommended when cleaning the TUS3400.
- *Water or rubbing alcohol* – A cloth moistened with water or rubbing alcohol can be used to clean TUS3400.
- *Using solvents* – The use of solvents is not recommended when cleaning the TUS3400 as they may damage the plastic parts.
- *Vacuum cleaner* – Using a vacuum specifically designed for computers is one of the best methods of cleaning the TUS3400. Dust and dirt can restrict the airflow in the TUS3400 and cause its circuitry to corrode.
- *Cotton swabs* - Cotton swaps moistened with rubbing alcohol or water are excellent tools for wiping hard to reach areas.
- *Foam swabs* - Whenever possible, it is best to use lint free swabs such as foam swabs for cleaning.

A.2.3 Federal Communication Commission Interference Statement

This equipment has been tested and found to comply with the limits for a Class B digital

device, pursuant to part 15 of the FCC Rules. These limits are designed to provide reasonable protection against harmful interference when the equipment is operated in a commercial environment. This equipment generates, uses, and can radiate radiofrequency energy and, if not installed and used in accordance with the instruction manual, may cause harmful interference to radio communications. Operation of this equipment in a residential area is likely to cause harmful interference in which case the user will be required to correct the interference at his own expense.

FCC Caution: Any changes or modifications not expressly approved by the party responsible for compliance could void the user's authority to operate this equipment.

This device complies with part 15 of the FCC Rules.

Operation is subject to the following two conditions:

- (1) This device may not cause harmful interference, and
- (2) this device must accept any interference received, including interference that may cause undesired operation.

This transmitter must not be co-located or operating in conjunction with any other antenna or transmitter.

Radiation Exposure Statement:

This equipment complies with FCC radiation exposure limits set forth for an uncontrolled environment. This equipment should be installed and operated with minimum distance 20cm between the radiator & your body.

Note: The country code selection is for non-US model only and is not available to all US model. Per FCC regulation, all WiFi product marketed in US must be fixed to US operation channels only.

Chapter

6

Hazardous Materials Disclosure

B.1 Hazardous Material Disclosure Table for IPB Products Certified as RoHS Compliant Under 2002/95/EC Without Mercury

The details provided in this appendix are to ensure that the product is compliant with the Peoples Republic of China (China) RoHS standards. The table below acknowledges the presences of small quantities of certain materials in the product, and is applicable to China RoHS only.

A label will be placed on each product to indicate the estimated “Environmentally Friendly Use Period” (EFUP). This is an estimate of the number of years that these substances would “not leak out or undergo abrupt change.” This product may contain replaceable sub-assemblies/components which have a shorter EFUP such as batteries and lamps. These components will be separately marked.

Please refer to the table on the next page.

TUS3400

Part Name	Toxic or Hazardous Substances and Elements					
	Lead (Pb)	Mercury (Hg)	Cadmium (Cd)	Hexavalent Chromium (CR(VI))	Polybrominated Biphenyls (PBB)	Polybrominated Diphenyl Ethers (PBDE)
Housing	X	O	O	O	O	X
Display	X	O	O	O	O	X
Printed Circuit Board	X	O	O	O	O	X
Metal Fasteners	X	O	O	O	O	O
Cable Assembly	X	O	O	O	O	X
Fan Assembly	X	O	O	O	O	X
Power Supply Assemblies	X	O	O	O	O	X
Battery	O	O	O	O	O	O

O: This toxic or hazardous substance is contained in all of the homogeneous materials for the part is below the limit requirement in SJ/T11363-2006

X: This toxic or hazardous substance is contained in at least one of the homogeneous materials for this part is above the limit requirement in SJ/T11363-2006

此附件旨在确保本产品符合中国 RoHS 标准。以下表格标示此产品中某有毒物质的含量符合中国 RoHS 标准规定的限量要求。

本产品上会附有“环境友好使用期限”的标签，此期限是估算这些物质“不会有泄漏或突变”的年限。本产品可能包含有较短的环境友好使用期限的可替换元件，像是电池或灯管，这些元件将会单独标示出来。

部件名称	有毒有害物质或元素					
	铅 (Pb)	汞 (Hg)	镉 (Cd)	六价铬 (CR(VI))	多溴联苯 (PBB)	多溴二苯醚 (PBDE)
壳体	X	O	O	O	O	X
显示	X	O	O	O	O	X
印刷电路板	X	O	O	O	O	X
金属螺帽	X	O	O	O	O	O
电缆组装	X	O	O	O	O	X
风扇组装	X	O	O	O	O	X
电力供应组装	X	O	O	O	O	X
电池	O	O	O	O	O	O

O: 表示该有毒有害物质在该部件所有物质材料中的含量均在 SJ/T11363-2006 标准规定的限量要求以下。
X: 表示该有毒有害物质至少在该部件的某一均质材料中的含量超出 SJ/T11363-2006 标准规定的限量要求。