

# IER 506B

## PRINTER

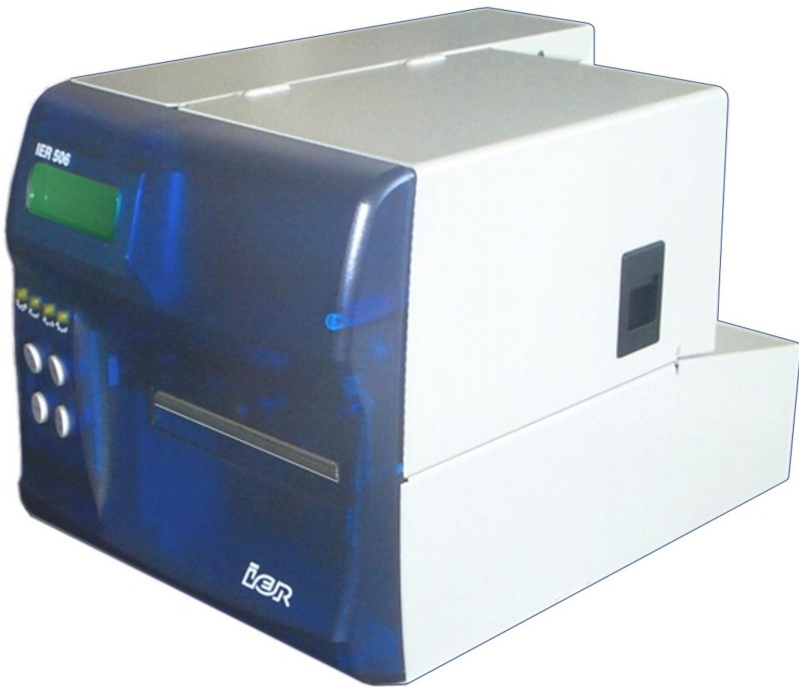

## User Guide

### N0B402A

## **IER SIEGE - HEADQUARTERS**

### **IER S.A.**

3, rue Salomon de Rothschild  
92156 SURESNES CEDEX  
FRANCE  
Tel. +33 (0)1 41 38 60 00  
Fax +33 (0)1 41 38 62 75

## **IER dans le monde - IER Worldwide**

### **CHINA**

---

#### **IER Shanghai**

Kuen Yang Plaza #1101  
798 Zhao Jia Bang Road  
SHANGHAI 200030  
P.R.C.  
Phone: +86 (21) 6473 6792  
Fax: +86 (21) 6473 6806

### **SINGAPORE**

---

#### **IER PTE Ltd**

120 Lower Delta Road  
#14-13/16 Cendex Centre  
SINGAPORE 169208  
Phone: +65 6276 6966  
Fax: +65 6271 5563

### **UNITED ARAB EMIRATES**

---

#### **IER Dubai**

PO Box 37585  
DUBAI  
Phone: +971 4 347 67 20  
Fax: +971 4 347 67 03

### **UNITED STATES**

---

#### **IER Inc. Dallas**

2015 Midway Road, Suite 118  
CARROLLTON TX 75006  
Phone: +1 (972) 991 2292  
Fax: +1 (972) 991 1044  
Toll free: 1-800 624 8538

#### **IER Inc. Belton**

815 Kirkley Blvd  
BELTON TX 76513  
Phone: +1 (254) 933 5000  
Fax: +1 (254)933 5050

### **GERMANY**

---

#### **IER GmbH**

Praklastr. 1  
D-31311 UETZE  
Phone: +49 (0) 5173/6906 30  
Fax: +49 (0) 5173/6906 50

### **SPAIN**

---

#### **IER Impresoras Especializadas, S.L.**

C/ Torre de Don Miguel, 23  
E-28031 - MADRID  
Phone: +34 91 535 89 75  
Fax: +34 91 535 89 76

### **UNITED KINGDOM**

---

#### **IER Ltd**

Unit G4  
Middlesex Business Centre  
Bridge Road  
SOUTHALL, MIDDX, UB2 4AB  
Phone: +44 (0)208 744 7650  
Fax: +44 (0)208 744 7670

---

## **NOTICE**



**THIS PRODUCT COMES WITH A LITHIUM BATTERY. BATTERY REPLACEMENT MUST IMPERATIVELY BE PERFORMED BY QUALIFIED MAINTENANCE PERSONNEL. MOREOVER, ONLY IER APPROVED MODELS MAY BE USED.**



**DANGER OF EXPLOSION IF BATTERY IS INCORRECTLY REPLACED. REPLACE ONLY WITH THE SAME OR EQUIVALENT TYPE RECOMMENDED BY THE MANUFACTURER. DISPOSE OF USED BATTERIES ACCORDING TO THE MANUFACTURER'S INSTRUCTIONS.**

---

The United States Federal Communications Commission (in 47 CFR 15.105) has specified that the following notice be brought to the attention of users of this product.

**NOTE:** This equipment has been tested and found to comply with the limits for a Class B digital device, pursuant to Part 15 of the FCC Rules. These limits are designed to provide reasonable protection against harmful interference in a residential installation. This equipment generates, uses and can radiate radio frequency energy and, if not installed and used in accordance with the instructions, may cause harmful interference to radio communications. However, there is no guarantee that interference will not occur in a particular installation.

If this equipment does cause harmful interference to radio or television reception, which can be determined by turning the equipment off and on, the user is encouraged to try to correct the interference by one or more of the following measures:

- Reorient or relocate the receiving antenna.
- Increase the separation between the equipment and receiver.
- Connect the equipment into an outlet on a circuit different from that to which the receiver is connected.
- Consult the dealer or an experienced radio/TV technician for help.

Pursuant to Part 15.21 of the FCC Rules, any changes or modifications to this equipment not expressly approved by IER could void the user's authority to operate this equipment.

Use of a shielded cable is required to comply within Class B limits of Part 15 of FCC Rules.

**NORWAY: This product is also designed for IT power distribution system with phase-to-phase voltage 230V.**

**NORWAY & SWEDEN: Apparaten skall anslutas till jordat uttag när den ansluts till ett nätverk.**

---



**WARNING**

**THIS APPLIANCE MUST BE GROUNDED.  
THIS PRODUCT MUST EXCLUSIVELY BE CONNECTED  
TO AN ELECTRICAL CIRCUIT THAT IS**

- PROVIDED WITH A GROUND FAULT CIRCUIT INTERRUPTER (GFCI) COMPLYING WITH IEC 364 AND NFC15-100 REGULATIONS, AND**
  - CONFORMING WITH THE VOLTAGE CHARACTERISTICS SPECIFIED BY THE NF EN 50160 STANDARD.**
- 

The cover(s), door(s) and/or drawer(s) of this product is (are) intended for occasional use and must be normally closed.

The warranty shall be null and void in case of use of any spare part, special tool or consumable not expressly approved in writing by IER and in the event of attempted repair or servicing of the machines by persons lacking the requisite technical qualifications.

**This document contains proprietary information of IER. It may not be reproduced or communicated without prior written authorization of IER. It is intended solely for the use of the product described herein, to the exclusion of any other usage.**

**It is provided as is, for information purposes only, without any warranty of any kind, including any warranty of fitness or a particular purpose, and may be modified by IER at any time.**

*The information and specifications contained in this document are subject to change without prior notice.*

*Translated from French - IER Documentation Department*

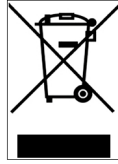

In compliance with the European Directive 2002/96/CE relative to the management of Waste Electrical and Electronic Equipment (WEEE) implemented as of August 13, 2005, this product may not be disposed of with regular household waste. All products concerned by this directive are marked with the above symbol.

The end owner of this product is responsible for either:

- Transferring the product to an authorized treatment facility where the product components, recognized to present a hazard to the environment and/or public health, will be recycled and recovered properly, or
- Consulting with the manufacturer for appropriate product waste management according to the terms of the manufacturer.

# CONTENTS

<b>1. GENERAL .....</b>	<b>8</b>
<b>1.1 CONTENTS OF THE SHIPPING CONTAINER .....</b>	<b>8</b>
<b>1.2 IER 506B PRINTER DESCRIPTION .....</b>	<b>9</b>
<b>2. CONNECTING THE PRINTER AND POWER UP....</b>	<b>10</b>
<b>2.1 CONNECTING THE PRINTER.....</b>	<b>10</b>
2.1.1 PROCEDURES .....	10
2.1.1.1 Connecting the Printer to the AC Power .....	11
2.1.1.2 Connecting the Printer to the Data Communications System .....	12
<b>2.2 POWERING UP THE IER 506B PRINTER.....</b>	<b>13</b>
2.2.1 PROCEDURE .....	13
<b>2.3 POWERING DOWN THE IER 506B PRINTER.....</b>	<b>14</b>
2.3.1 PROCEDURE .....	14
<b>3. LOADING BLANK MEDIA AND INSERTING IT .....</b>	<b>15</b>
<b>3.1 LOADING FANFOLD MEDIA.....</b>	<b>15</b>
3.1.1 PROCEDURE .....	15
<b>3.2 LOADING ROLL MEDIA - FIRST GENERATION MEDIA         HOLDER.....</b>	<b>16</b>
3.2.1 PROCEDURE .....	16
<b>3.3 LOADING ROLL MEDIA - SECOND GENERATION MEDIA         HOLDER .....</b>	<b>18</b>
3.3.1 PROCEDURE .....	18
<b>3.4 ADJUSTING THE PAPER PATH WIDTH.....</b>	<b>20</b>
3.4.1 PROCEDURE .....	20
<b>3.5 INSERTING BLANK MEDIA INTO THE PRINTER.....</b>	<b>23</b>
3.5.1 PROCEDURE .....	23
<b>4. PRINTER OPERATION.....</b>	<b>24</b>
<b>4.1 IER 506B PRINTER FRONT PANEL .....</b>	<b>24</b>
<b>4.2 MODES OF IER 506B PRINTER OPERATION .....</b>	<b>26</b>
<b>4.3 PRINTING DOCUMENTS.....</b>	<b>26</b>
4.3.1 PROCEDURE .....	26

<b>5. PRINTER MAINTENANCE.....</b>	<b>28</b>
<b>5.1 RECOMMENDED PERIODIC MAINTENANCE SCHEDULE.....</b>	<b>28</b>
5.1.1 PERIODIC MAINTENANCE SCHEDULE.....	28
5.1.2 PRELIMINARY STEPS.....	29
<b>5.2 PERIODIC MAINTENANCE PROCEDURES.....</b>	<b>30</b>
5.2.1 REMOVING DUST FROM THE PRINTER INTERIOR .....	30
5.2.2 CLEANING THE PRINTHEAD AND PLATEN.....	32
<b>5.3 RESTORING THE PRINTER TO OPERATIONAL CONDITION....</b>	<b>34</b>
5.3.1 STEPS TO BE CARRIED OUT BEFORE USING THE PRINTER .....	34
<b>6. TROUBLESHOOTING.....</b>	<b>35</b>
<b>6.1 OPERATING FAULTS .....</b>	<b>35</b>
6.1.1 AT SWITCH-ON THE PRINTER DOES NOT START UP.....	35
6.1.2 THE PRINTER DOES NOT RECEIVE ANY MESSAGES FROM THE HOST.....	35
6.1.3 MEDIA FEEDING PROBLEM.....	36
6.1.4 POOR PRINT QUALITY.....	36
6.1.5 MOST FREQUENT ERROR MESSAGES.....	37
<b>6.2 CLEARING A DOCUMENT JAM.....</b>	<b>38</b>
6.2.1 PROCEDURES .....	38
6.2.1.1 Clearing a Document Jam Automatically.....	39
6.2.1.2 Clearing a Document Jam Manually.....	40
<b>6.3 OPENING THE PRINTHEAD ASSEMBLY.....</b>	<b>41</b>
6.3.1 PROCEDURE .....	41
<b>6.4 CLOSING/LOCKING THE PRINTHEAD ASSEMBLY.....</b>	<b>43</b>
6.4.1 PROCEDURE .....	43
<b>7. PRINTER PROVIDED WITH AN OPTIONAL   STACKER.....</b>	<b>45</b>
<b>7.1 STACKER OPTION .....</b>	<b>45</b>
<b>7.2 CLEARING A PAPER JAM IN THE MOTORIZED STACKER.....</b>	<b>47</b>
7.2.1 PROCEDURE .....	47

# 1 GENERAL

## 1.1 CONTENTS OF THE SHIPPING CONTAINER

The box contains the following items:

- IER 506B Printer
- User Guide
- AC power cord
- Set of test coupons, one of which containing the default (factory) configuration of the printer.

**IMPORTANT:** We recommend that you save the packing material at least throughout the warranty period. Also, make sure to keep the IER 506B Printer User Guide and coupon with the default (factory) configuration with your printer.

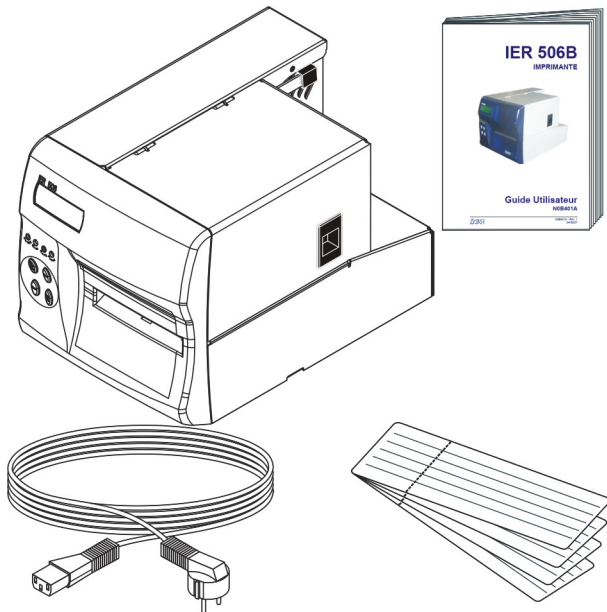

**Figure 1.1**  
**Contents of the Shipping Container**



## 1.2 IER 506B PRINTER DESCRIPTION

The IER 506B Printer is designed to print bag tags and ATB1 type documents.

The print technology used by this printer is the direct thermal method requiring the use of heat-sensitive media.

Continuous blank bag tag or boarding pass media feeding takes place through the rear feed slot. The IER 506B Printer accepts fanfold media or roll media if fitted with the IER roll media holder option.

The standard output slot of the IER 506B Printer comes with a serrated tear strip for tearing off the printed document.

Optionally, the IER 506B Printer can feature two automatic document separation systems:

- Burster, for media provided with perforations.
- Cutter for applications requiring varying lengths for the printed documents.

Printers equipped with the automatic document separation system can be equipped with an optional stacker. This stacker, available in two versions, either motorized or non motorized, attaches to the front panel and collects (exclusively) ATB1 size documents for delivery in sets, see page 45

For applications offering luggage tracking during transport by means of Radio Frequency Identification (RFID), the optional RFID module of the IER 506B Printer allows printing and encoding of bag tags featuring a radio frequency antenna.

## 2 CONNECTING THE PRINTER AND POWER UP

### 2.1 CONNECTING THE PRINTER

---



**WARNING**

This appliance must be grounded.

This product must exclusively be connected to an electrical circuit that is

- Provided with a ground fault circuit interrupter (gfc) complying with iec 364 and nfc15-100 regulations, and
  - conforming with the voltage characteristics specified by the nf en 50160 standard.
- 

#### 2.1.1 Procedures

To connect the printer, simply proceed as follows:

- Connect it to the AC power
- Connect it to the data communications system (PC, network)

Auxiliary connectors may exist on your printer if the corresponding optional interfaces are installed for serial RS232, USB, Ethernet, or UHF connections.

Note: For these specific applications to be operational, it may be necessary to install additional programs and to perform the corresponding configurations (contact IER Technical Support).

### 2.1.1.1 Connecting the Printer to the AC Power



**IT IS IMPORTANT TO PROCEED IN THE ORDER BELOW:**

- a) Make sure the printer is switched off (power switch set to the **0**-position).
- b) Plug the power cord (1) into the corresponding connector at the rear of the printer.
- c) Connect the power cord to the line power outlet.

**Note:** The printer switches automatically to the available AC line power within the authorized voltage range.

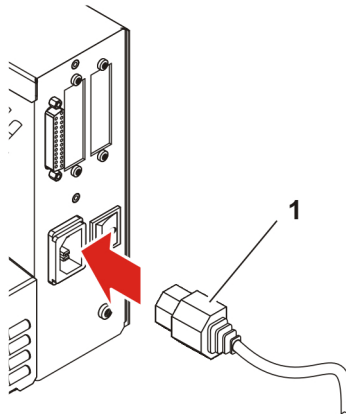

1 - Power cord

### Connecting the Printer to the AC Power

### 2.1.1.2 Connecting the Printer to the Data Communications System



- To comply with class A FCC regulations it is necessary to use a data cable provided with a braided shield.
- Use a shielded RS232 cable fitted with metal plated connector hoods. The cable shield must be linked to these hoods and cable length must not exceed 15 m (49.2 ft).
- The length of a USB cable must not exceed 5 m (16.4 ft).

Depending on the printer configuration, connect either the:

- serial data I/O cable (1) to the RS232 connector, located at the rear of the printer, or the
- USB cable (2) to the corresponding connector at the rear of the printer.

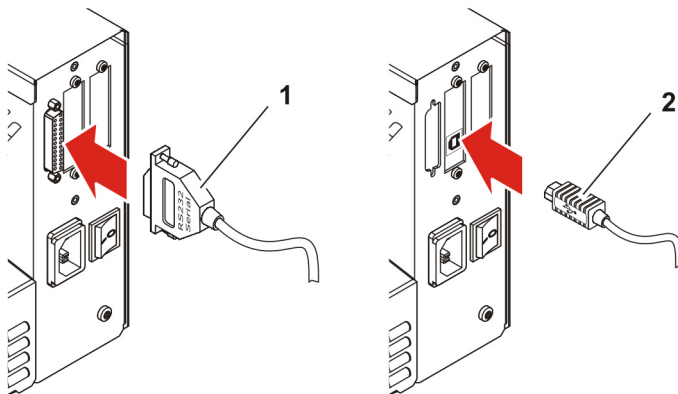

- 1 - Serial RS232 data I/O cable
- 2 - USB cable

**Figure 2.2**  
**Connecting the I/O Data cable**

## 2.2 POWERING UP THE IER 506B PRINTER

### 2.2.1 Procedure

- a) At the rear of the printer, set the AC power switch to the I-position

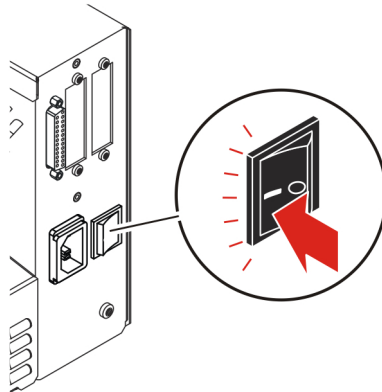

**Figure 2.3**  
**Powering Up the Printer**

For a few seconds, the printer tests the heating elements of the printhead and displays the test results.

On completion of the testing phase, the printer either

- beeps and displays a message requesting paper loading if no media has been loaded, see page 23, or
- is ready for printing, if media has been loaded.

## 2.3 POWERING DOWN THE IER 506B PRINTER

### 2.3.1 Procedure

- a) At the rear of the printer, set the AC power switch to the 0-position.

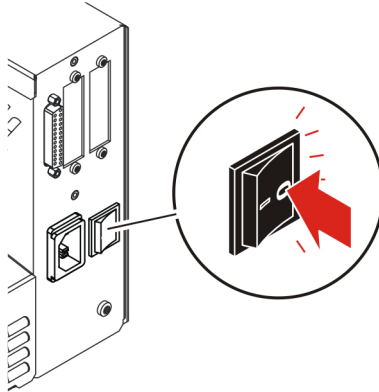

**Figure 2.4**  
**Powering Down the Printer**

## 3 LOADING BLANK MEDIA AND INSERTING IT

### 3.1 LOADING FANFOLD MEDIA

#### 3.1.1 Procedure

- a) Install the box of blank fanfold media at the rear of the printer by following the instructions below:

**IMPORTANT:** Make sure to place the box:

- parallel to the printer
- centered in relation to the insertion slot
- with the heat-sensitive side of the media facing up

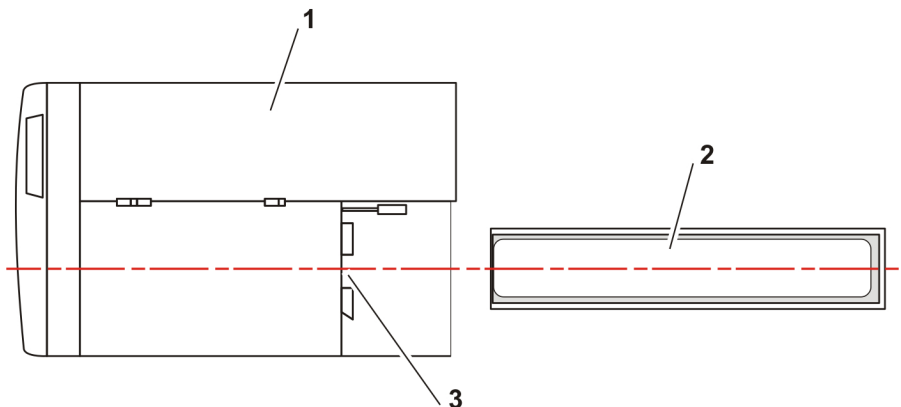

- 1 - Printer top view  
2 - Box with fanfold media  
3 - Media insertion slot

**Figure 3.1**  
**Correctly Installing the Box of Fanfold Media**

## 3.2 LOADING ROLL MEDIA - FIRST GENERATION MEDIA HOLDER

### 3.2.1 Procedure

**IMPORTANT:** When installing the media roll, make sure that the heat-sensitive side of the media will be facing up when inserted into the printer.

- a) Remove the removable flange (4).
- b) Place the media roll (2) on the plastic hubs (3) and set it against the fixed flange (1).
- c) Install the removable flange (4) on the spindle of the media holder and set it against the media roll (2).

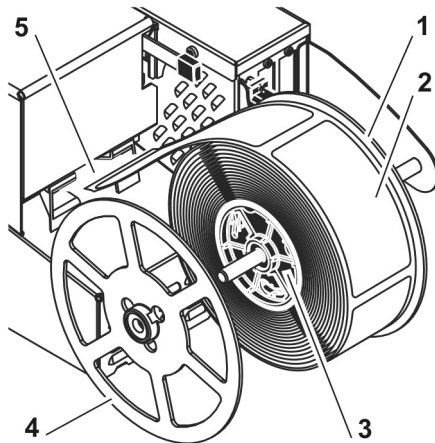

- 1 - Fixed flange
- 2 - Media roll
- 3 - Plastic hubs
- 4 - Removable flange
- 5 - Media insertion slot

**Figure 3.2**  
**Installing Roll Media**



**IMPORTANT:** Check that the roll (2) is centered in relation to the insertion slot (5). If this is not the case, contact the help desk.

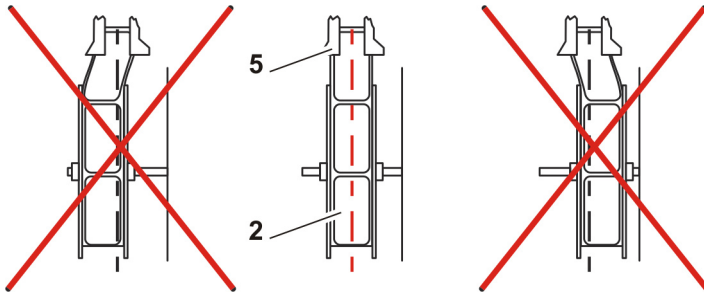

- 2 - Media roll
- 5 - Insertion slot

**Figure 3.3**  
**Correctly Installing the Roll Media**

## 3.3 LOADING ROLL MEDIA - SECOND GENERATION MEDIA HOLDER

### 3.3.1 Procedure

**IMPORTANT:** When installing the media roll, make sure that the heat-sensitive side of the media will be facing up when inserted into the printer.

- a) Slide the roll media holder adjustment pin (3) outwards.
- b) Place the media roll (2) on the plastic spindle (4) and set it against the holder (1).
- c) Slide the pin (3) back and set it against the roll.

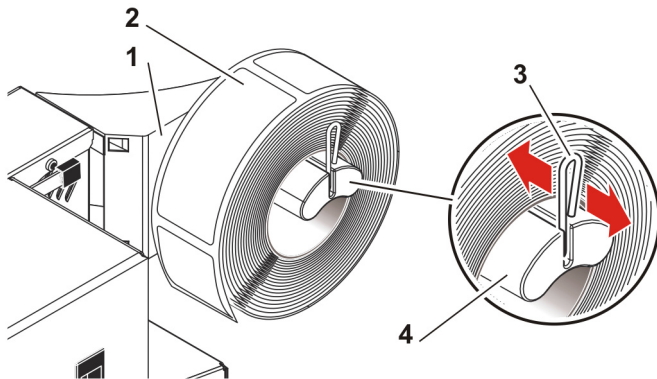

- 1 - Roll Media Holder
- 2 - Media roll
- 3 - Adjustment pin
- 4 - Spindle

**Figure 3.4**  
**Installing Roll Media**

**IMPORTANT:** Check that the roll (2) is centered in relation to the insertion slot (5). If this is not the case, contact the help desk.

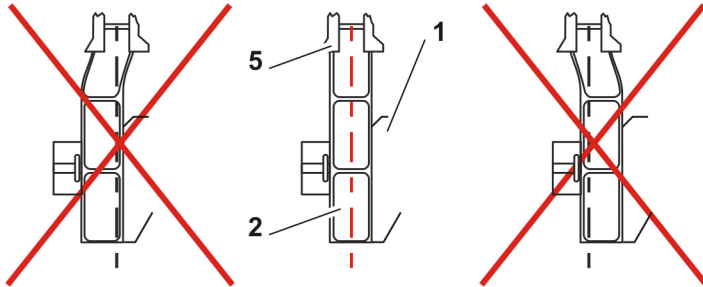

- 1 - Roll media holder
- 2 - Media roll
- 5 - Insertion slot

**Figure 3.5**  
**Correctly Installing the Roll Media**

## 3.4 ADJUSTING THE PAPER PATH WIDTH

**Preliminary Steps:** - Correctly load the printer with the appropriate media stock, refer to the relevant chapter in the User Guide.

### 3.4.1 Procedure

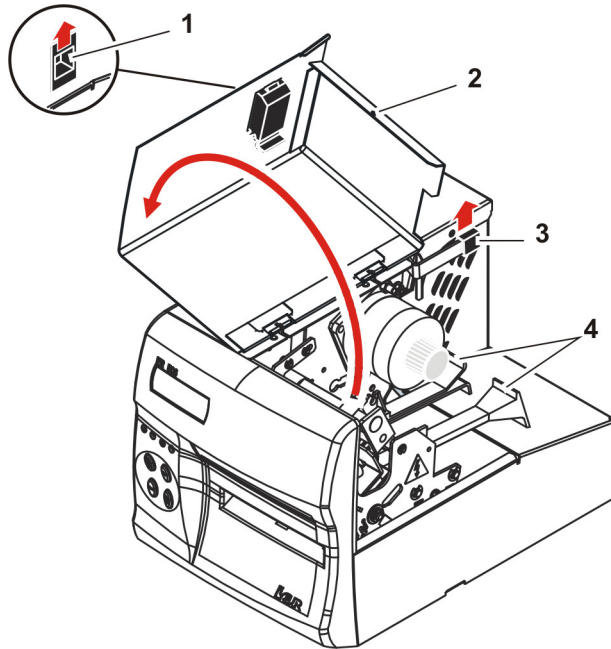

- Push latch (1) to open the printer cover (2).
- Lift the printhead lever (3) and locate the two paper guides (4) making up the paper path.

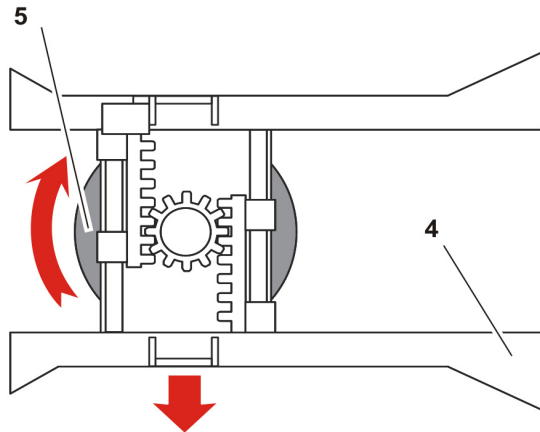

- Loosen the paper guide locking wheel (5) located under the paper guides (4).
- Move the outer paper guide (4) outwards.

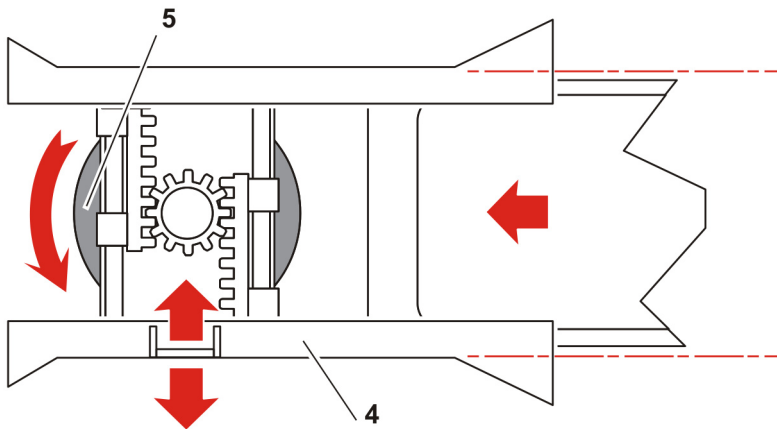

- Insert the media into the two paper guides until it protrudes from the front.
- Fine-adjust the distance between the two guides to ensure that media feeding is smooth and accurate at the same time, i.e. without friction nor excessive play.

- Having adjusted the paper guides (4), retighten the paper guide locking wheel (5).

**Final Steps:** - Lower the printhead lever (3) and close the printer cover (2).

## 3.5 INSERTING BLANK MEDIA INTO THE PRINTER

- Preliminary Steps:**
- Adjust the paper path width, see page 20
  - Power up the printer, see page 13

### 3.5.1 Procedure

- Insert the leading document of the fanfold or roll media stock into the insertion slot, made up of the two paper guides (1).
- Push the document into the printer until it is sensed and drawn in.

**Note:** Once the document has been pulled in, printer initialization starts, i.e. the media is correctly positioned according to the printer configuration and to the type of separating marks.

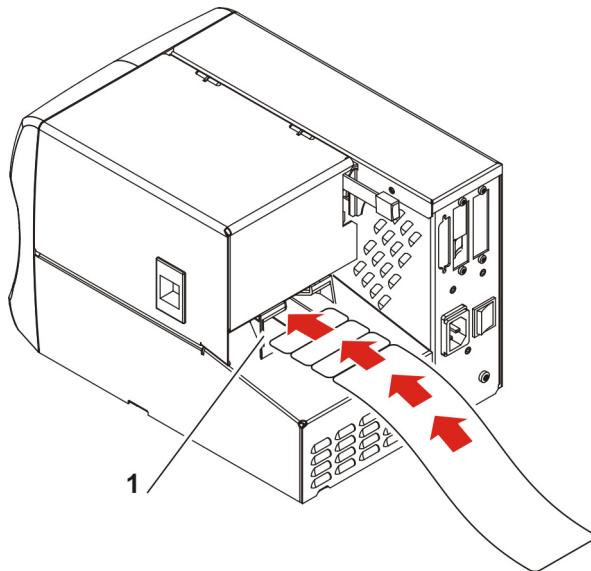

1 - Insertion slot

**Figure 3.9**  
**Inserting Blank Media**

## 4 PRINTER OPERATION

### 4.1 IER 506B PRINTER FRONT PANEL

The printer front panel features the following elements:

- 4-line by 20-alphanumeric character Liquid Crystal Display (LCD) module (1)
- Four indicators (2) see table page 25
- Four keys (3) see table page 25,
- Output slot (4).



**Figure 4.1**  
**IER 506B Printer Front Panel**



Name	Status	Meaning
<b>On/Off</b>	Off	<i>Off line</i> mode operation
	On	<i>On line</i> mode operation
<b>Error</b>	Blinking	Reception error
	Steadily on	Hardware error
<b>Rcvg</b>	On	Message reception in progress. LED is automatically turned off on completion of message reception.
<b>Power</b>	On	Printer powered up

### Control Panel LED Indicator Functions

Key	On line Mode	Off line Mode
<b>On/Off Line</b>	Press this key to select the <i>off line</i> mode.	Press this key to select the <i>on line</i> mode.
<b>Test</b>	n.a.	Press this key to print out the test coupons or select the configuration mode.
<b>Reset</b>	Press this key to: <ul style="list-style-type: none"> <li>- acknowledge an operating error</li> <li>- stop the sound alarm</li> <li>- clear a paper jam without lifting the printhead.</li> </ul>	Press this key repeatedly to remove the blank media from the inside of the printer through the rear feed slot.
<b>Paper Feed</b>	n.a.	Press this key to eject a blank coupon (function can be inhibited).

### Control Panel Key Functions

## 4.2 MODES OF IER 506B PRINTER OPERATION

The printer features two modes of operation:

- *On line* mode, used for normal printer operation.  
In this mode, the printer to host connection is active.
- *Off line* mode giving access to the following three functions:
  - Printing test documents, refer to the IER 506B Maintenance Manual, IER P/N **NOB472A**,
  - Configuring the printer, refer to the IER 506B Printer Technical Manual, IER P/N **NOB412A**,
  - Ejecting a document through the rear feed slot, see page 38.

In this mode, the printer to host connection is inactive.

## 4.3 PRINTING DOCUMENTS

**Preliminary Steps:** Before starting to print, it is important to check the following:

- Printer connection to the AC line power and the data I/O source, see page 10
- Printer power up, see page 13
- Media loading, see page 23
- Printer Functions, see page 24

### 4.3.1 Procedure

- a) Set the printer to the **On line** mode by pressing the **On/Off line** key.
- b) Send a print command from the host system.  
The **Reception** indicator lights up and remains lit until the document is printed.

When printing is completed and if the printer features the optional cutter or buster, the document is automatically separated from the continuous media and made available to the operator.

On the standard model, the upper edge of the output slot is provided with a serrated tear-off strip. This allows the operator to easily separate the printed document by tearing it off the continuous media with a fast upward movement.

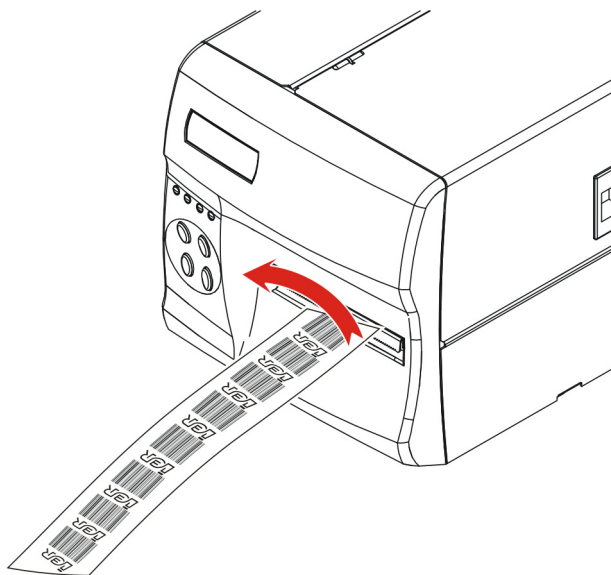

**Figure 4.2**  
**Separating the Printed Document: Tear-Off Method**

## 5 PRINTER MAINTENANCE

### 5.1 RECOMMENDED PERIODIC MAINTENANCE SCHEDULE

**Schedule:** Every two weeks or after printing 2000 m (6562 ft) of documents, whichever occurs first.

**Estimated Time:** 15 min.

**Tools Required / Maintenance Products:** - Cleaning kit, IER P/N S32129A

---



**WARNING**

**Before starting any of these operations, make sure to:**

- remove any media from the printer
  - switch off the printer
  - disconnect the printer from the AC power source
  - disconnect the data I/O cable from the printer
- 

#### 5.1.1 Periodic Maintenance Schedule

For optimum printer performance under normal operating conditions, **IER** recommends the following periodic maintenance schedule: **every two weeks** or after printing of **2000 m (6562 ft)** of documents, whichever occurs first.

**IMPORTANT:** However, the periodic maintenance schedule must be adapted to the particular printer environment and operating conditions (presence of dust, quality of the media used, throughput, etc.)

To carry out these operations, it is essential to use the **IER** Cleaning Kit, P/N **S32129A** and to follow the procedures described in the present document.

---



**CAUTION**

**IER will not be responsible for any problem consequent to the customer's failure to adhere to the recommendations regarding the maintenance schedule, the maintenance products and the specific instructions to follow.**

---

## 5.1.2 Preliminary Steps

- Open the cover.
- Fully open the printhead, see page 41.

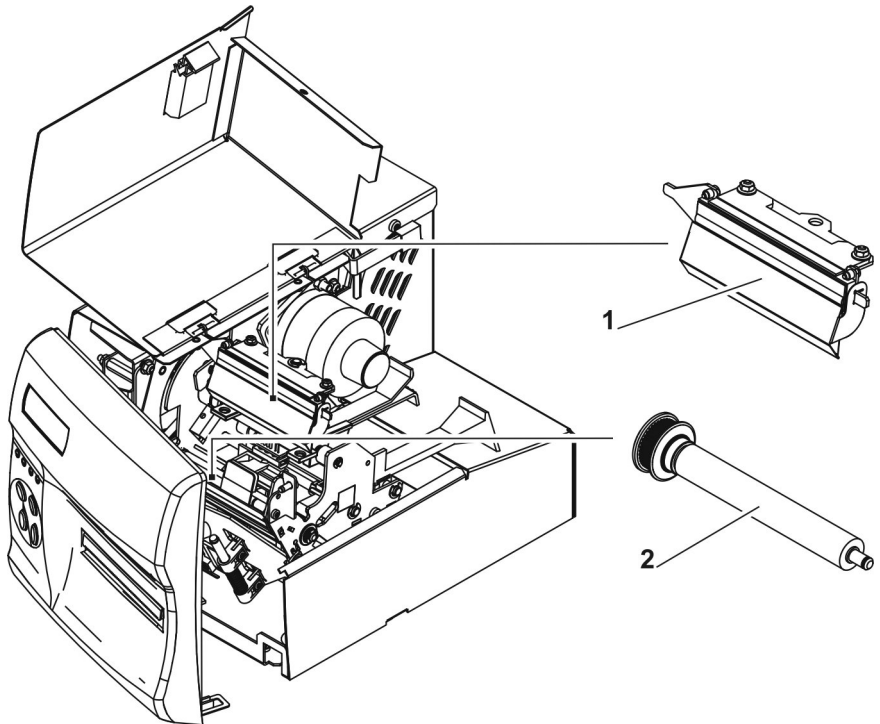

- 1 - Printhead
- 2 - Platen

**Figure 5.1**  
**Elements Concerned by the Periodic Maintenance**

## 5.2 PERIODIC MAINTENANCE PROCEDURES

### 5.2.1 Removing Dust from the Printer Interior



**WARNING**

To carry out this operation, *IER* recommends that you use exclusively the can with compressed air supplied with the cleaning kit, since it has been tested and approved non-flammable and non-explosive.

*IER* will not be responsible if any another product is used.

**DO NOT USE THE DUSTER CAN IF THERE IS ONLY LITTLE AIR LEFT. THE CAN CONTAINS MOSTLY PROPELLANT WHICH IGNITES EASILY WHEN EXPOSED TO THE SLIGHTEST SPARK.**

---

Use the duster can supplied with the *IER* Cleaning Kit and follow the safety precautions on the can and those mentioned above, blow air into the printer to dislodge any paper chaff and dust by directing the air blow to the following zones:

- Arrow #5: inside the two paper guides
- Arrow #4: under the two paper guides and into the printing mechanism
- Arrow #3: to the end of the paper path around the sensor
- Arrow #2: to the front of the printhead and behind the front panel where the optional cutter or burster is located (if applicable)
- Arrow #1: to the front ejection slot

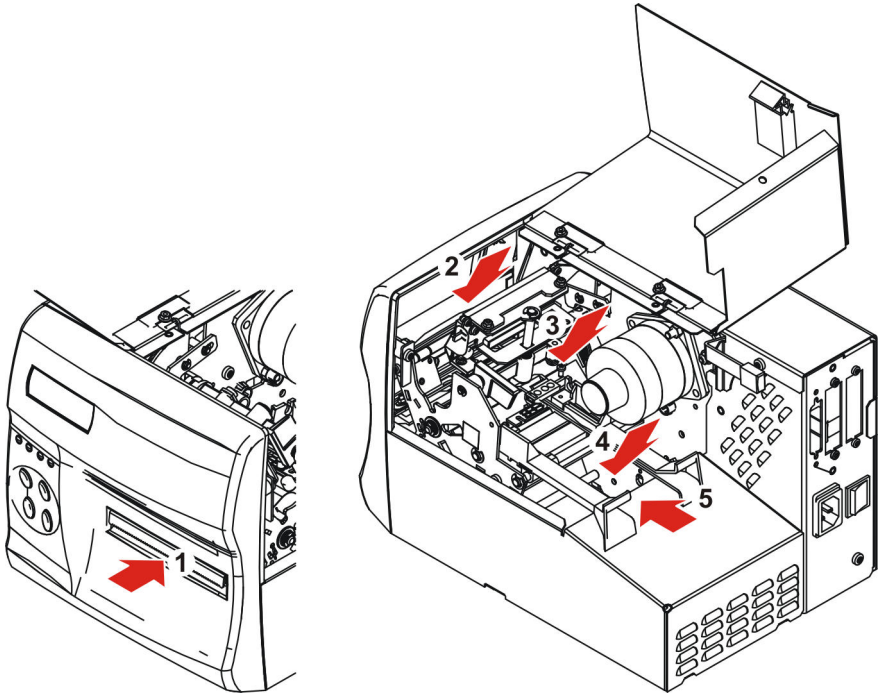

**Figure 5.2**  
**Removing Dust from the Printer**

## 5.2.2 Cleaning the Printhead and Platen

---



- The printhead is a sensitive electronic component:**
- before handling it, put on an anti-static wrist strap,
  - avoid physical shocks to the printhead,
  - do not use tools that may damage the printhead,
  - do not touch the printhead heating elements.
- 

Proceed as follows, using the products in the **IER** cleaning kit and following the enclosed instructions:

- a) Using a soft, lint-free cloth lightly moistened with the recommended cleaning product, clean the entire platen surface (2). To accomplish this, turn the motor drive knob (3) so as to cover the whole surface of the platen (2).
- b) Using alcohol filled foam swabs, clean the whole surface of the printhead heating elements (1).



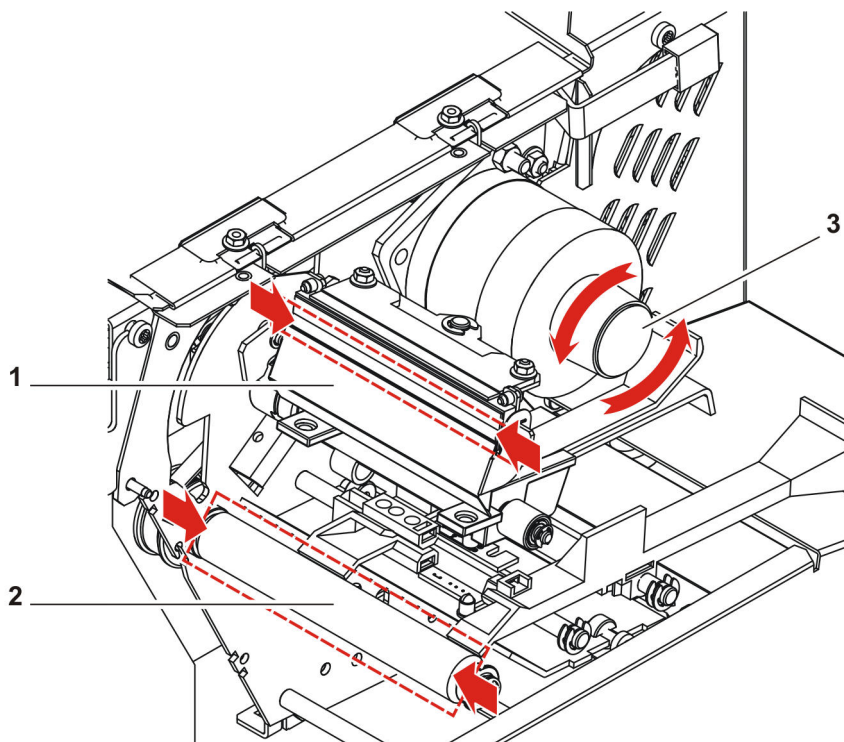

- 1 - Printhead
- 2 - Platen
- 3 - Motor drive knob

**Figure 5.3**  
**Cleaning the Printhead and Platen**

## 5.3 RESTORING THE PRINTER TO OPERATIONAL CONDITION

### 5.3.1 Steps to be Carried out Before Using the Printer

Having carried out the periodic maintenance operations, it is necessary to:

- to close and lock the printhead assembly, see page 43
- to connect the data I/O cable and the AC power cable, see page 10
- switch on the printer, see page 13
- load the printer with media, see page 23
- print a document to check the print quality, see page 26

## 6 TROUBLESHOOTING

### 6.1 OPERATING FAULTS

Printer operating faults usually generate an error message on the display and a sound alarm.

**Note:** A short beep (5 sec. approx.) signals a minor fault, whereas a long beep indicates a hardware problem.

#### 6.1.1 At Switch-On the Printer Does not Start Up

- a) Switch the printer off (set the power switch to the **0**-position).
- b) Check the AC line power by plugging in another electrical appliance.
- c) Check that the AC power cord is correctly plugged into the power connector on the printer and the line power outlet.
- d) Power up the printer (set the power switch to the **I**-position) and check that the **Power** indicator lights up.

If the printer still fails to power up, call the help desk.

#### 6.1.2 The Printer Does Not Receive Any Messages from the Host

- a) Power down the printer (set the power switch to the **0**-position).
- b) Check that the data transmission cable is properly connected to the printer and to the IT system (computer, network, hub, etc.).
- c) Power up the printer (set the AC power switch to the **I**-position) and check that the **Power** indicator lights up.
- d) Ensure that the **On / Off** indicator is on. If not, press the **On/Off Line** key and check that the wording **On Line Mode** is displayed.
- e) Send a printing command from the host to the printer and check that the task is executed.

If the above steps do not correct the fault, call the help desk.

### 6.1.3 Media Feeding Problem

- a) Check that the printhead assembly is correctly locked, see page 43
- b) Insert the media into the printer and place it under the printhead assembly, see page 23
- c) Make sure there is no paper chaff in the paper path that could interfere with media feeding.

If all these corrective actions do not solve the problem, call the help desk.

### 6.1.4 Poor Print Quality

Poor print quality can have several reasons:

- Dirty printing mechanism
- Printing parameter settings do not correspond to the media used
- Faulty part

Call the help desk, whatever the reason.

## 6.1.5 Most Frequent Error Messages

**IMPORTANT:** Having solved the problem encountered, press the Reset key to reinitialize the printer.

Message displayed	Reason
RECEPT. DEFAULT erron. message	Command syntax error. Send the command again. If this results in a second failure, call the help desk.
RECEPT. DEFAULT transmis. default	Data transmission error. Check data I/O cable connection. Send the command again. If this results in a second failure, call the help desk.
WARNING paper out	Out of media. Load new media: - see page 15, - see page 16, - see page 18, - see page 23.
WARNING paper jam	Paper jam inside the printer. Open the printer cover, locate the paper jam and remove the jammed document, see page 38. If necessary, open the printhead assembly, see page 41.

### Error Messages

## 6.2 CLEARING A DOCUMENT JAM

- Preliminary Steps:**
- Refer to the description of the key and indicator functions, see figure page 24
  - Refer to the description of the modes of printer operation, see page 26

### 6.2.1 Procedures

A jammed document can be removed either automatically or manually.

We recommend manual removal in the event of an important jam or if a document cannot be removed automatically.

**Note:** If necessary, open the printer cover to locate and remove the document causing the problem.

### 6.2.1.1 Clearing a Document Jam Automatically

- a) Press the **On/Off Line** key to switch to Off line mode.
- b) Repeatedly press the **Reset** key until the faulty document has left the site of the jam and appears at the rear insertion slot.
- c) Grasp the document and remove it by hand.

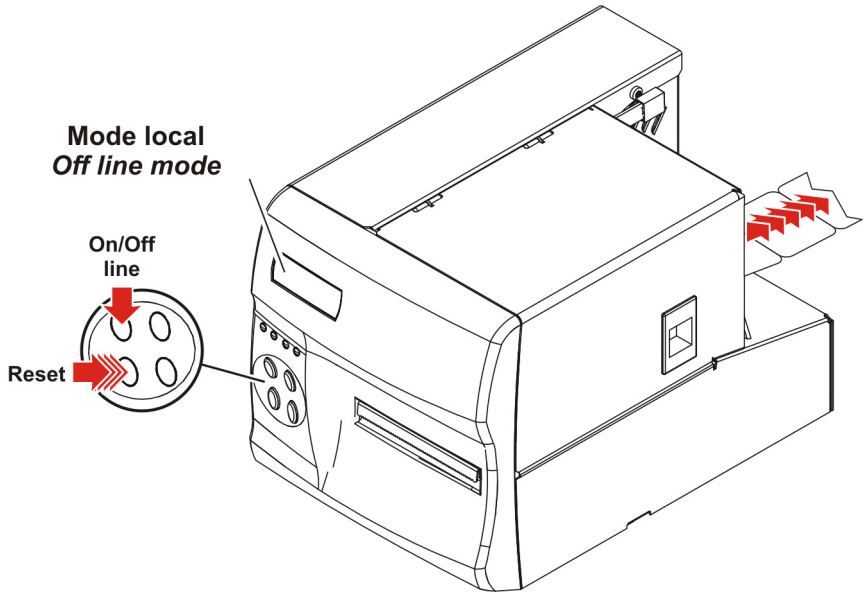

**Figure 6.1**  
**Clearing a Document Jam Automatically**

### 6.2.1.2 Clearing a Document Jam Manually

- a) Raise the paper drive lever (1) and grasp the document. Pull it out of the printer through the rear slot.
- b) Lower the paper drive lever (1) once the document has been removed from the printer.

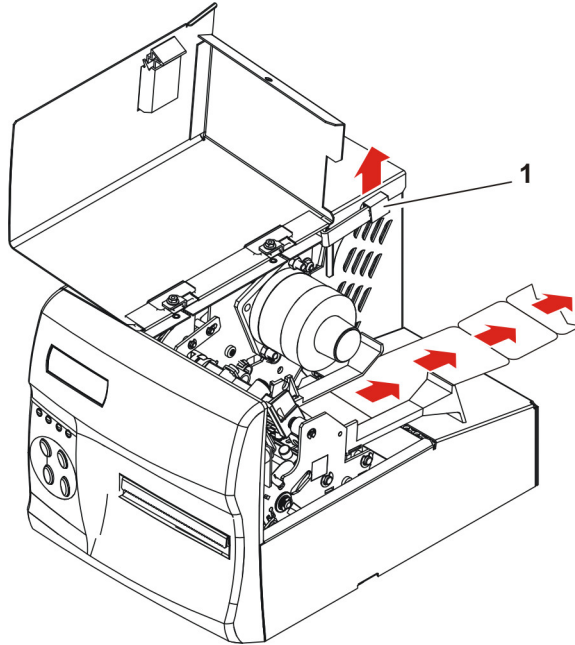

1 - Paper drive lever

**Figure 6.2**  
**Clearing a Document Jam Manually**

**IMPORTANT:** Should you need to unlock and move the paper guides to remove the jammed document more easily, imperatively readjust the guide position to the width of the media used before operating the printer again, see page 20.

**Final Steps:** Having removed the jammed document, reload the printer with media see page 23.



## 6.3 OPENING THE PRINTHEAD ASSEMBLY



Before performing any service operation on the printer:

- unload the paper from the printer,
- switch off the printer,
- disconnect the printer from the power supply,
- disconnect the data cable.



The printhead is a sensitive electronic component, therefore it is essential:

- to put on an anti-static wrist strap, before handling it
- to avoid any shock to the printhead
- not to use any tools that could damage it
- not to touch the line of heating elements

**IMPORTANT:** Make sure the printhead assembly is closed and locked during normal printing operation.

Note: Open the printhead assembly only when necessary, for example, when you need to have access to the paper path to clear a paper jam, or to service the printer.

**Preliminary Steps:** - Open the printer cover.

### 6.3.1 Procedure

- a) Raise the printhead lever (1) to unlock the printhead assembly.
- b) Pull and rotate the printhead support (2) to the rear to be able to rotate the printhead assembly.
- c) The printhead assembly is fully open when the printhead (3) is in its vertical position.

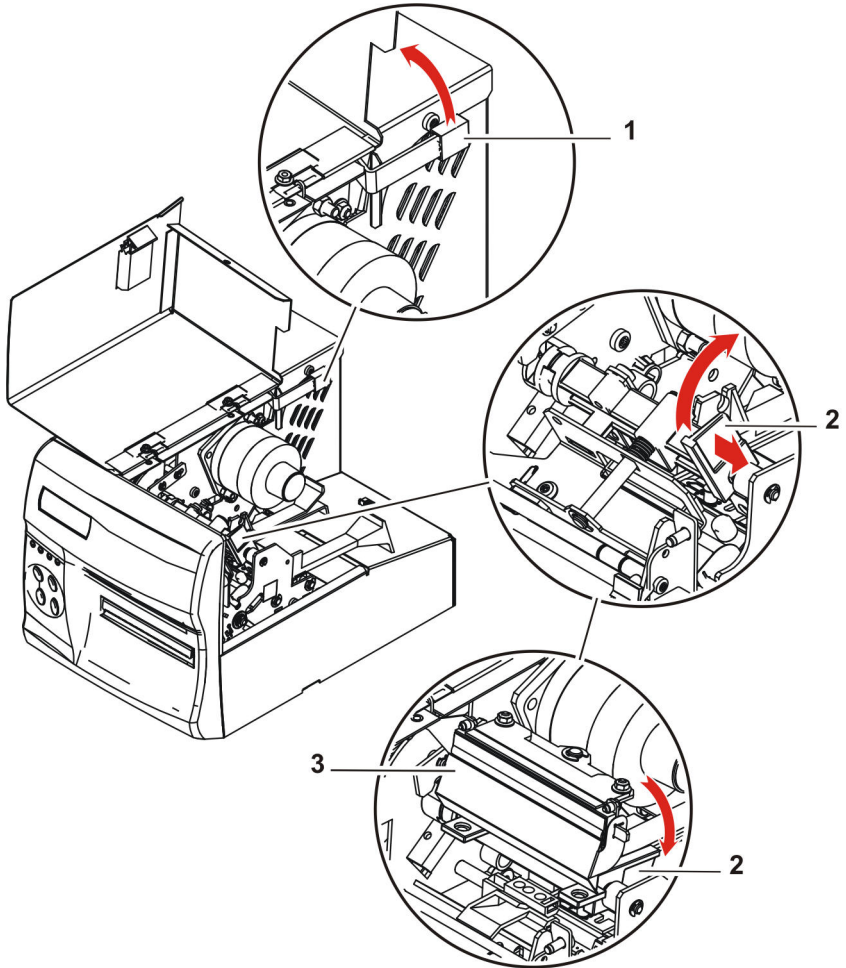

- 1 - Printhead lever
- 2 - Printhead support
- 3 - Printhead

**Figure 6.3**  
**Opening the Printhead Assembly**

## 6.4 CLOSING/LOCKING THE PRINTHEAD ASSEMBLY

### 6.4.1 Procedure

- a) Fully rotate the printhead support (2) towards the front until the printhead assembly locks into its lower position.
- b) Lower the printhead lever (1) to lock the printhead assembly into the operating position.
- c) If no other service operation is to be performed on the printer:
  - close the printer cover
  - connect the data I/O cable
  - connect the printer to the power source
  - switch on the printer
  - and load the printer with media

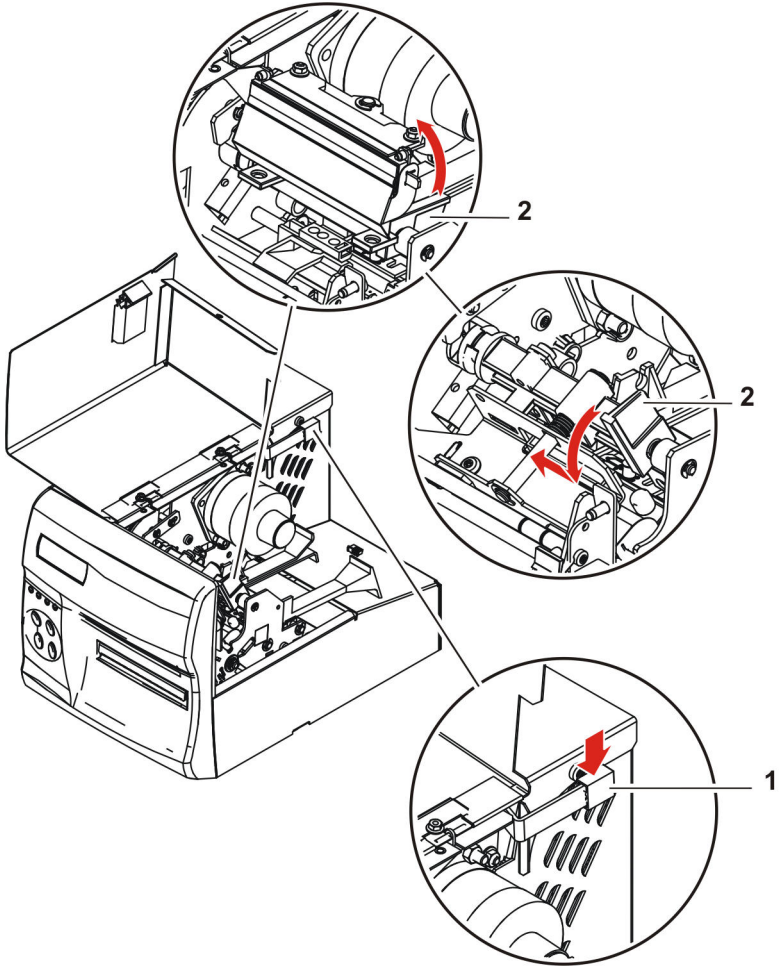

- 1 - Printhead lever
- 2 - Printhead support

**Figure 6.4**  
**Closing/Locking the Printhead Assembly**

## 7 PRINTER PROVIDED WITH AN OPTIONAL STACKER

### 7.1 STACKER OPTION

**IMPORTANT:** This option can exclusively be used with ATB1 type media.

An optional stacker can be added on the printer, to collect the printed documents. The storage capacity of the stacker is 10 to 15 documents, depending on media grammage.

Two stacker models are available:

- Standard model offering a frontal presentation of the documents
- Motorized stacker presenting the printed documents vertically

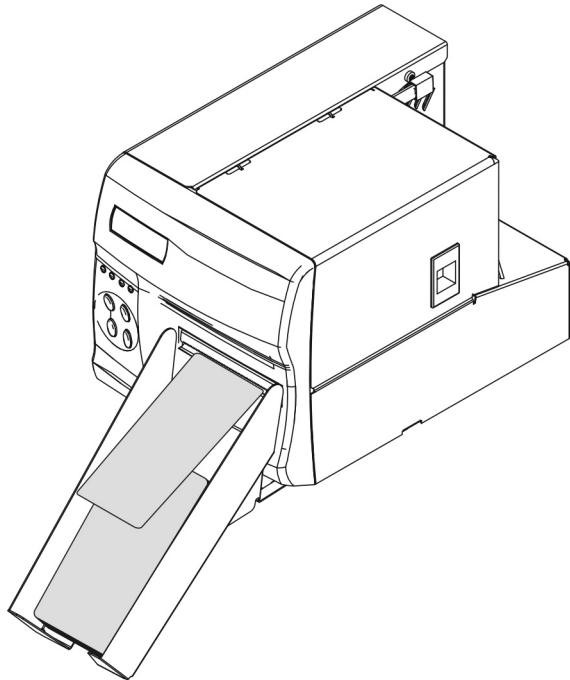

**Figure 7.1**  
**Standard Stacker**

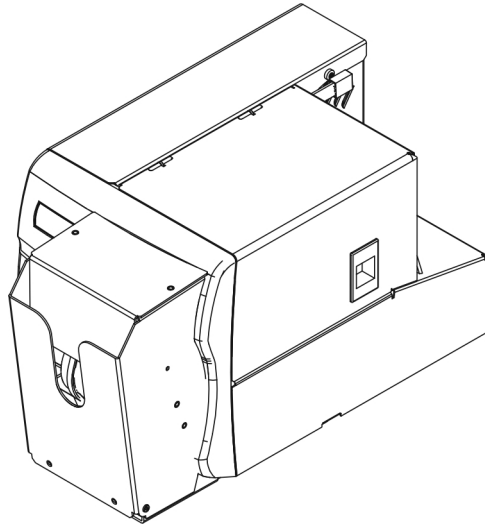

**Figure 7.2**  
**Motorized Stacker**

## 7.2 CLEARING A PAPER JAM IN THE MOTORIZED STACKER

### 7.2.1 Procedure

To remove a jammed document from the stacker, swing the stacker open to have access to the printer front panel. Then, simply pull on the document located between the printer output slot and the stacker drive roller and remove it.

Having cleared the jam, rotate the stacker back to its closed position against the front panel.

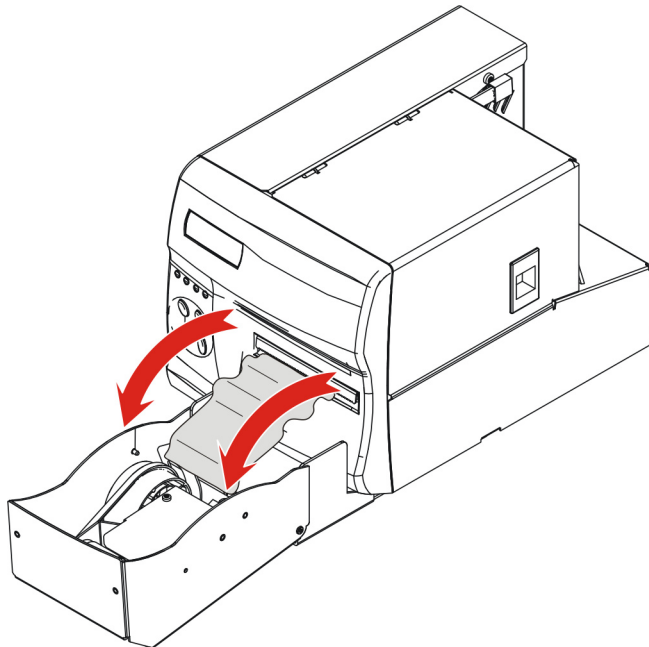

**Figure 7.3**  
**Clearing a Paper Jam in the Motorized Stacker**

