



ICC-1 connectivity module

Document ID: SCDOC-129-142

Author's name: Olof Blomé

Approver's name: Tomas Mellblom

Revision	Author's name	Comment	Revision date
0.1	Olof Blomé	Document created	2016-03-08
0.2	Olof Blomé	Formatting	2016-03-09
0.3	Olof Blomé	Added: <ul style="list-style-type: none">• Antenna gain -2.5dBi• Limitations on usage• Label guidance User manual regulatory info	2016-04-24
0.4	Sigma Connectivity	Added additional required host label text	2016-05-04
0.5	Sigma Connectivity	Layout updates Added limitation update	2016-05-16
0.6	Sigma Connectivity	Added info about the limited modular approval (LMA) for ICC-1 NA	2016-06-30
0.7	Sigma Connectivity	Added additional info in limitations.	2016-07-05



Contents

1	ICC-1 module description	4
1.1	Description of ICC-1	4
1.2	Pin description	5
1.3	Radio front-end and crystal	6
1.4	Type approval markings.....	6
1.5	Module physical size and footprint.....	7
1.6	Mounting options	7
2	Design rules for antenna integration	8
2.1	Distance to metal objects.....	9
2.2	Distance to plastic objects.....	9
2.3	Grounding of metal heat sink.....	10
2.4	Module mounting options	11
3	Power supply for ICC-1.....	12
3.1	Regulated power supply.....	12
3.2	Coin cell battery operation	12
4	Electrical specifications.....	13
4.1	Absolute maximum ratings.....	13
4.2	Recommended operating conditions	13
4.3	Environmental	13
4.4	Transceiver characteristics	14
4.5	Wake up timing	14
4.6	General purpose input/output.....	14
5	Regulatory instructions.....	15
5.1	Limitations	15
5.2	User manual.....	15
5.3	Label	15
6	Certification	16



6.1 FCC statement..... 16

6.2 Industry Canada statement..... 17

Figures

Figure 1 - Module with shield can 4

Figure 2 - Overview pin out numbering for ICC-1 5

Figure 3 - Silkscreen printing 6

Figure 5 - Physical dimensions of the ICC-1 module..... 7

Figure 6 - Antenna area front and back of module..... 8

Figure 7 - Metal free area to secure antenna performance 9

Figure 8 - Suggested grounding point 10

Figure 9 - Grounding point for heatsink..... 10

Figure 10 - Mounted 90 degree angle 11

Figure 11 - Flat board-to-board connection..... 11

1 ICC-1 module description

ICC-1 is a ZigBee module with integrated antenna with highly flexible input and output options. The ICC-1 module will be integrated within the IKEA TRÅDFRI wireless product range and is not a standalone product.

- IEEE Std- 802.15.4 compliant RF transceiver
- Supports ZigBee / Bluetooth Low Energy (BLE) / Thread on 2.4 GHz ISM band
- Output power maximum 10 dBm e.i.r.p and sensitivity up to -97 e.i.r.p with built-in PCB antenna
- Operational within -40°C to 125°C
- Module size is approximately 18.0 mm x 24.5 mm

1.1 Description of ICC-1

- 2.4 GHz 802.15.4 compliant module with multiple mounting options and configurations.
- 17 connections, 6 pins on the left and 10 pins on the right.
- 12 connections can be used as General-purpose input/output (GPIO) connections.
- Working temperature range -40° C to +125° C.
- Built-in thermistor to compensate crystal drift to control temperature variations.

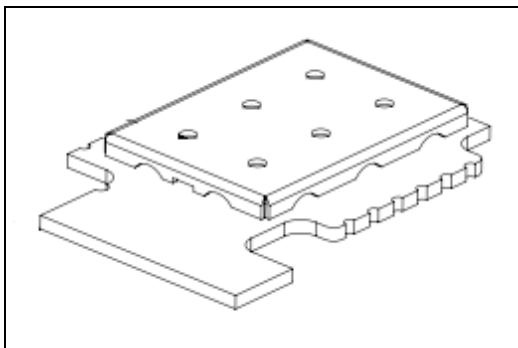

Figure 1 - Module with shield can

1.2 Pin description

The pin out is flexible and all pins can be configured as analogue port or data channel, such as I2C. Each GPIO has its own mux configuration and set of PU and PD. The software is defined for each product.

The pin number is counted from the lower left corner, see Figure 2.

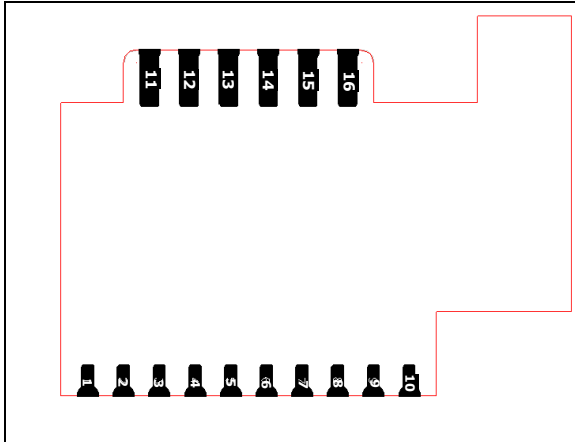

Figure 2 - Overview pin out numbering for ICC-1

Pin description					
Pin number	Logic number	Notes	Pin number	Logic number	Notes
1	GND	Connected to main ground	10	RESETn	Hardware reset
2	PB15	GPIO	11	VDD	Power supply
3	PB14	GPIO	12	GND	Ground
4	PC10	GPIO	13	PB13	GPIO
5	PC11	GPIO	14	PB12	GPIO
6	PF0	DBG_SWCLKTCK	15	PA1	GPIO
7	PF1	DBG_SWDIOTMS	16	PA0	GPIO
8	PF2	DBG_SWO	17	PC11	FTM
9	PF3	DBG_TDI			

1.3 Radio front-end and crystal

The ICC-1 radio chipset has a built-in balun. The radio output is connected to an antenna using a wave guide type of trace to minimize losses because of the two-layer structure of the PCB. The front-end has a discrete RF-filter to comply with harmonic emission regulations. The radio uses an XO with integrated frequency control via built-in thermistor to cover the wide temperature range.

If a stable slow clock source is needed, oscillators can be calibrated in runtime instead of using a dedicated 32 kHz clock.

1.4 Type approval markings

The ICC-1 module has a FCC ID and Industry Canada (IC) number silkscreen printing for reference located at the bottom. The host shall be labelled with *Contains Transmitter Module FCC ID: FHO-ICC-1 and IC: 10912A-ICC1*.

- ICC-1
- FCC ID: FHO-ICC-1
- IC: 10912A-ICC1

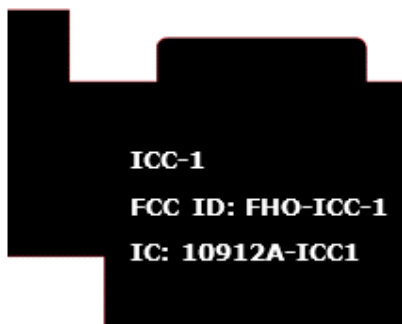

Figure 3 - Silkscreen printing

1.5 Module physical size and footprint

- Total width: 18 mm x 24.5 mm
- Height, including PCB and shield can: 2.1 mm

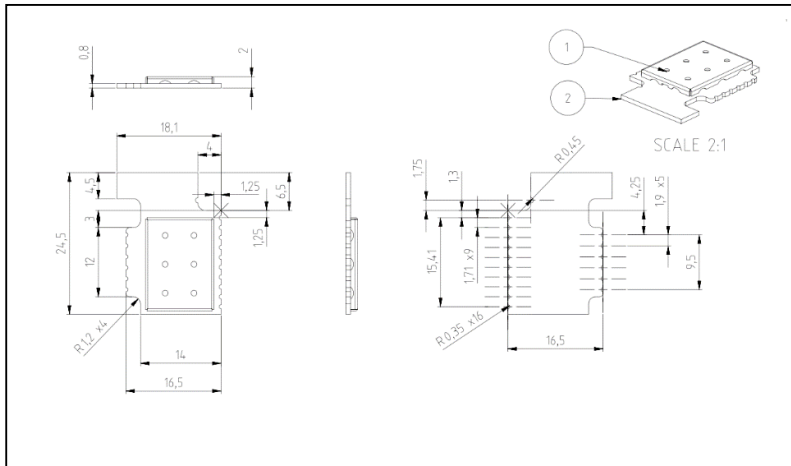

Figure 4 - Physical dimensions of the ICC-1 module

1.6 Mounting options

There are two mounting options for the ICC-1 module:

- Wave solder the 6 pin connector to the right in a 90° angle to the carrier board. See Figure 9 - Mounted 90 degree angle.
- Use standard surface mounting techniques for the board when soldered flat to a PCB. Follow the GND clearance guidelines on the carrier board. See Figure 10 - Flat board-to-board connection.

2 Design rules for antenna integration

The ICC-1 module can be integrated into various IKEA TRÅDFRI products. Follow the described antenna integration design rules to ensure acceptable and correct radiated performance. The antenna gain is -2.5dBi .

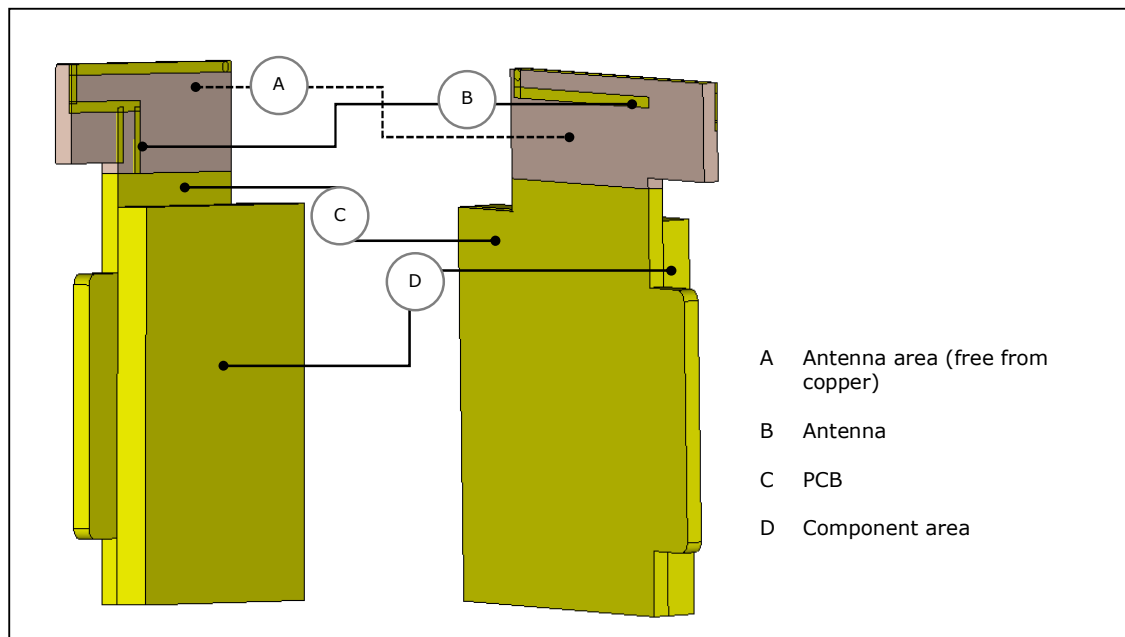

Figure 5 - Antenna area front and back of module

2.1 Distance to metal objects

Place large metal objects above the indicated surface as shown in Figure 6 and at least 30 mm from the antenna to secure antenna performance.

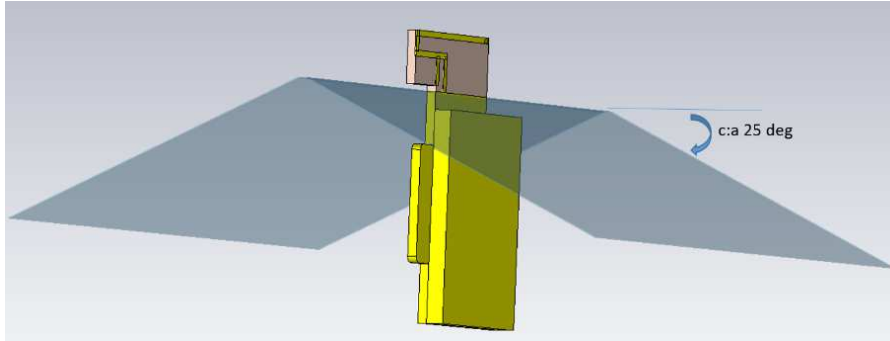

Figure 6 - Metal free area to secure antenna performance

2.2 Distance to plastic objects

Place large plastic objects at least 10 mm from the antenna. This can affect the resonance frequency.

2.3 Grounding of metal heat sink

When using opening A in the solder mask of the Poly PCB as shown in Figure 7, the antenna connection shall be as short and close to antenna feed as possible.

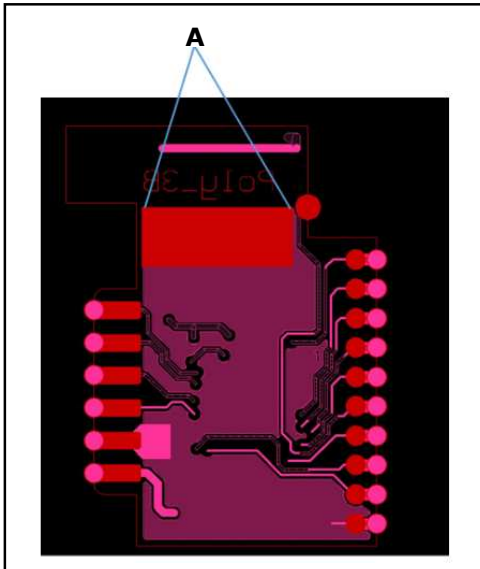

Figure 7 - Suggested grounding point

If integrated in LED bulbs, when inserted into an opening the module PCB shall be grounded to the heatsink plate as shown in Figure 8.

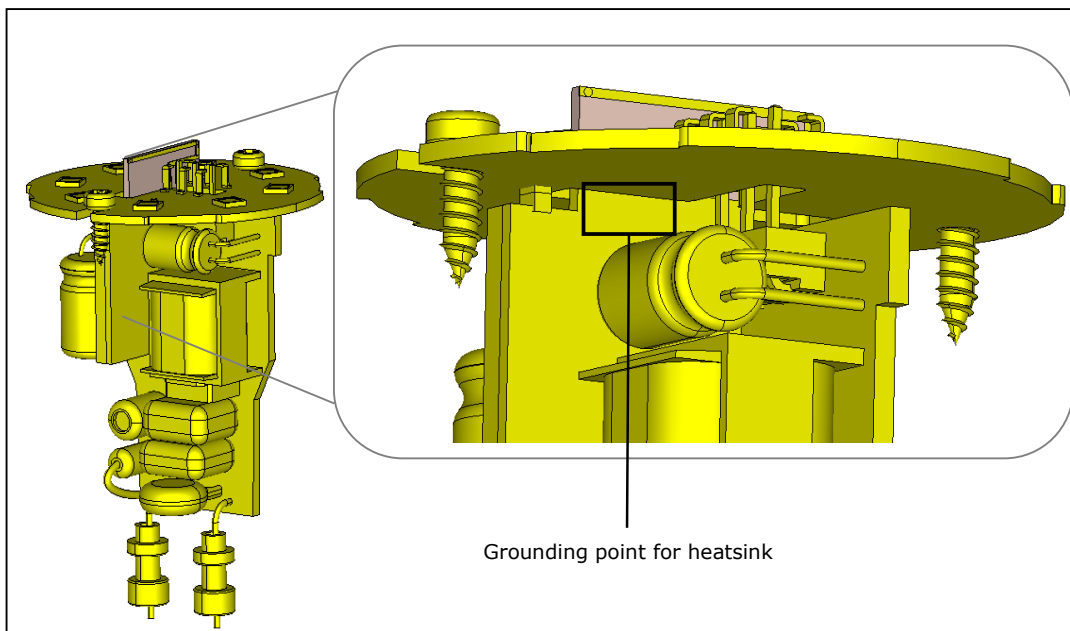

Figure 8 - Grounding point for heatsink

2.4 Module mounting options

If the ICC-1 module needs to be attached to another PCB during the integration process, the connections shall be solid and stable to prevent unwanted effects on the antenna performance. See Figure 10 and Figure 10 for possible attachment methods of the ICC-1 PCB to carrier board.

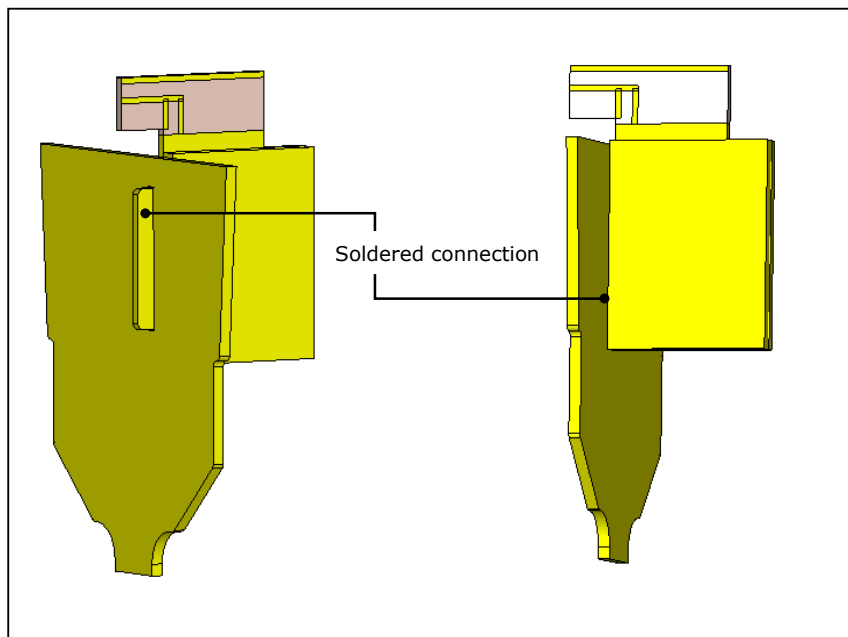

Figure 9 - Mounted 90 degree angle

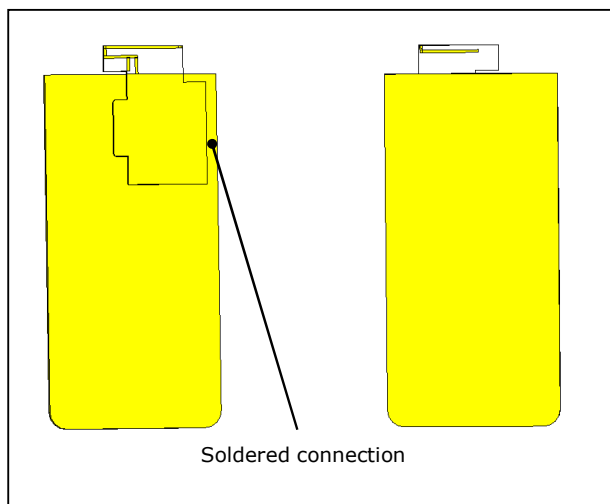

Figure 10 - Flat board-to-board connection

2.4.1 Noisy signals

Keep potentially noisy traces and components of the motherboard as far as possible from the antenna to prevent sensitivity of the module.



3 Power supply for ICC-1

3.1 Regulated power supply

ICC-1 can be supplied from a regulated power supply down to 1.85V in all conditions. During peak load transients, power supply can be up to 145mA when using high power mode. The product designer shall verify unconditional stability during peak load to secure that voltage is not dropping below 1.85V.

The actual design of the regulator affects the decoupling capacity. Make sure that no noise is injected via the power supply that impacts the analogue parts or the radio supply.

3.2 Coin cell battery operation

ICC-1 can be operated from a single 3.0V coin cell battery. A minimum of sustaining 1.85V during all peak transients until battery end of life is required to guarantee proper operation.

Make sure to fulfil the below requirements:

- Add enough decoupling to the device to avoid brown out during transient load in TX burst. $20\mu\text{F} < 200\mu\text{F}$.
- Limit output power to minimize peak power load.
- Schedule power consuming tasks to prevent tasks running parallel to minimize peak load.
- Minimize over the air communication (OTA), time to perform tasks (like pairing), fast poll, etc.
- Do not power the module via DCDC or other sources that have poor efficiency at light loads.



4 Electrical specifications

4.1 Absolute maximum ratings

Parameter	Condition	Min	Max	Unit
Ambient temperature range		-40	125	°C
Storage temperature		-50	150	°C
VDDMAX	External voltage supply	0	3.35 ¹	V
VDIGPIN	Voltage on any GPIO pin except pin 2 and pin 3	-0.3	V _{DD} + 2	V
VLFXOPIN	Voltage on pin 2 and pin 3	-0.3	V _{DD} + 0.3	V
IIOMAX	Current sink per I/O pin	0	50	mA

4.2 Recommended operating conditions

Parameter	Condition	Min	Typ	Max	Unit
Operating supply voltage	VREGVDD	1.62	3.3 ¹	3.35	V

4.3 Environmental

Parameter	Condition	Min	Typ	Max	Unit
VESDHBM	ESD HBM model			2	kV
VESDCDM	ESD CDM model			500	V

¹ Products using this module either uses battery with nominal voltage of 3.0V, or a regulated power at 3.3V or lower.



4.4 Transceiver characteristics

Parameter	Condition	Min	Typ	Max	Unit
Maximum TX power, 802.15.4 DSSS-QPSK	Conducted, 3.3V			14	dBm
RX Sensitivity 1% PER	Conducted, 20 octets			-99	dBm
FOFF	Input frequency offset tolerance 1% PER	-120		120	ppm
Co-channel interferer rejection 1% PER	Received signal 10dB above sensitivity level		-3		dB
Adjacent channel rejection 5MHz	Interferer +-1 channel spacing		55		dB
Adjacent channel rejection 10MHz	Interferer +-2 channel spacing		58		dB

4.5 Wake up timing

Parameter	Condition	Min	Typ	Max	Unit
From EM2 deep sleep	Executing RAM or cache		2.8	3.4	µs
From EM2 deep sleep	Executing from flash		7.8	10.4	µs

4.6 General purpose input/output

Parameter	Condition	Min	Typ	Max	Unit
VIOIL	Input low voltage			VDD*0.3	V
VIOIH	Input high voltage	VDDIO*0.7			V
VIOOL	Output low voltage relative to VDD			VDD*0.4	V
VIOOH	Output high voltage relative to VDD	VDDIO*0.6			V
IIOLEAK	Input leakage current		0.1		nA
RPU	I/O pin pull-up resistor	30	40	50	kOhm
RPD	I/O pin pull-down resistor	30	40	50	kOhm



5 Regulatory instructions

5.1 Limitations

ICC-1 shall only be installed in limb-worn devices and only be used as described in this document and cannot be co-located with other antennas or transmitters, exceptionally if specified in the grant condition of the equipment authorization. Other electronic functions not associated with the certified module or certified transmitter requires additional equipment authorization.

A host product itself is required to comply with all other applicable FCC equipment authorization regulations, requirements, and equipment functions that are not associated with the transmitter module portion. To ensure compliance for all non-transmitter functions, a host product manufacturer is responsible for ensuring compliance with the module(s) installed and fully operational.

ICC-1 fulfils the RF exposure requirements as portable limb-worn device and as mobile device, with a separation distance equal to or more than 20 cm between product and users body in normal operation.

ICC-1 must only be installed in portable limb-worn devices (not body worn) or in mobile devices with a separation distance equal to or more than 20 cm from users body under normal operations.

If ICC-1 is installed in a mobile device (host), a special text needs to be added in the host user manual. This text needs to include information regarding the separation distance and advise the end user that it is not allowed to be closer than 20 cm from the device during normal operation. The text needs to be in both English and French language.

5.2 User manual

User manual for license-exempt radio using the ICC-1 module needs to contain ICC-1 regulatory information.

5.3 Label

The label for license-exempt radio using the ICC-1 module shall be printed separately and needs to contain the FCC ID/ISED certification number clearly visible on the product.



6 Certification

The ICC-1 module is certified with FCC ID: FHO-ICC-1 and Industry Canada IC: 10912A-ICC1.

Caution: *Changes or modifications not expressly approved by the party responsible for compliance could void the user's authority to operate the equipment.*

For more information, go to: http://www.ecfr.gov/cgi-bin/text-idx?SID=a1be5f56bcd8d1391a26085ba51c6478&mc=true&node=se47.1.15_121&rqn=div8.
http://www.ecfr.gov/cgi-bin/text-idx?SID=a1be5f56bcd8d1391a26085ba51c6478&mc=true&node=se47.1.15_121&rqn=div8

6.1 FCC statement

This device complies with part 15 of the FCC Rules.

Operation is subject to the following two conditions:

- (1) This device may not cause harmful interference, and
- (2) This device must accept any interference received, including interference that may cause undesired operation.

Note: This equipment has been tested and found to comply with the limits for a Class B digital device, pursuant to part 15 of the FCC Rules.

These limits are designed to provide reasonable protection against harmful interference in a residential installation.

This equipment generates, uses and can radiate radio frequency energy and, if not installed and used in accordance with the instructions, may cause harmful interference to radio communications.

However, there is no guarantee that interference will not occur in a particular installation.

If this equipment does cause harmful interference to radio or television reception, which can be determined by turning the equipment off and on, the user is encouraged to try to correct the interference by one or more of the following measures:

- Reorient or relocate the receiving antenna.
- Increase the separation between the equipment and receiver.



- Connect the equipment into an outlet on a circuit different from that to which the receiver is connected.
- Consult the dealer or an experienced radio/TV technician for help.

6.2 Industry Canada statement

This device complies with Industry Canada's license-exempt RSSs.

Operation is subject to the following conditions:

- (1) This device may not cause interference; and
- (2) This device must accept any interference, including interference that may cause undesired operation of the device.
- (3) Changes or modification not expressly approved by the party responsible for compliance could void the user's authority to operate the equipment.

6.2.1 Avis d'industrie Canada

Le présent appareil est conforme aux CNR d'Industrie Canada applicables aux appareils radio exempts de licence. L'exploitation est autorisée aux deux conditions suivantes:

- (1) l'appareil ne doit pas produire de brouillage, et,
- (2) l'utilisateur de l'appareil doit accepter tout brouillage radioélectrique subi, même si le brouillage est susceptible d'en compromettre le fonctionnement.
- (3) Tout changement ou modification non expressément approuvé par la partie responsable de la conformité peut annuler le droit de l'utilisateur à utiliser l'équipement.