

E529.RF Thermostat Installation Guide

The e529.RF battery-operated thermostat is designed to work in conjunction with an HVAC controller to monitor and maintain room temperature (other devices may also be controlled from the e529.RF).



There are three general scenarios for using the e529.RF:

- A basic IRAS application with the e529.RF communicating wirelessly to another device
- An IRAS application with RF communication to a network backbone
- An IRAS application with wired communication to a network backbone

Installation



CAUTION!

- The e529.RF is intended for indoor use only.
- The E529.RF installer must be a trained, experienced service technician.
- All wiring must comply with local codes and ordinances.
- Failure to follow the instructions provided with the product could damage the product or cause a hazardous condition.

Placement

Without the need for power input, the e529.RF affords great placement options for optimal performance with virtually any fan coil unit, heat pump, or packaged terminal air conditioner found in guestrooms.

Since RF is critical to the e529.RF's operation, placement of the device and careful consideration of possible sources of radio interference are important. For instance, the unit should not be placed close to floor or ceiling or near pipe or other metal pieces.

To minimize external conditions interference with room temperature measurement, locate the e529.RF away from external doors or windows and areas in direct sunlight.

Mounting Instructions

Separate the e529.RF body and the mounting plate by pulling the bottom of the mounting plate away from the e529.RF body and then pull the mounting plate down.

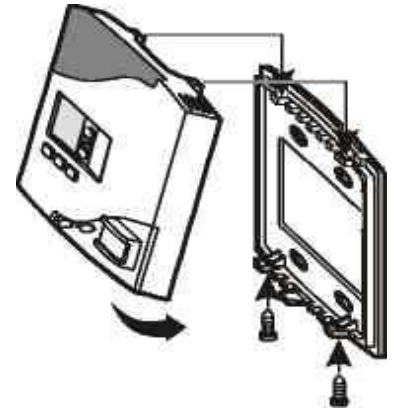

NOTE: If the back-mounting plate is rotated more than 2 or 3 degrees, the plastic tabs at the top of the plate may fracture or break off.

- Attach the mounting plate to the wall or electrical box with the arrow embossed on the mounting plate pointing upward.
- The e529.RF is provided with four 6-32 3/4" sheet metal screws for mounting the plate to an existing 4" x 4" electrical box. If attaching the mounting plate to sheetrock or a similar wall surface, install four 6-8 x 3/4 anchors. The four holes on the mounting plate can be used to mark the location for the anchors.
- Install the four AA alkaline batteries (NOTE: Use alkaline batteries only) provided into the battery compartment located on the rear of the e529.RF. Depress the battery clamp latch at the top of the battery compartment and then swing open the battery clamp. Insert the 4 AA alkaline batteries, matching the "+" terminals on the batteries to the "+" symbols in the battery compartment. Close the battery clamp and verify the latch is securely fastened.
- Verify that the e529.RF display is now showing information. If the display is blank, verify that the batteries are completely installed with the right polarities and that the batteries are not dead.

- Hook the tabs at the top rear of the e529.RF housing into the matching depressions at the top of mounting plate and rotate the bottom of the e529.RF housing toward the wall until it snaps into the place on the mounting plate.
- Secure the e529.RF housing to the mounting plate with the two small screws provided with the e529.RF. The screws thread into two small holes on the bottom of the e529.RF housing (see figure above).

Service Mode

The installation technician must enter the e529.RF's Service Mode to set parameters for uniquely identifying a room, binding the INNCOM devices in the room to that identity, setting the operational characteristics of the devices, and, if necessary, connecting the room to floor- or building-wide network.

Entering Service Mode

To enter Service Mode

1. Press and **hold** the °F/°C button on the e529.RF
2. Press and release the OFF/AUTO button
3. Press and release the DISPLAY button
4. Release the °F/°C button

Entering Values in Service Mode

- **rId**— Sets Room ID, a number that uniquely identifies the room to other device or on a network. Room ID consists of 5 digits divided into 3 bytes of data labeled HI_MED_LO (default is 6_55_35). The number will be included on the commissioning list and generally corresponds to the actual room number.
 - Enter Service Mode
 - At rId, press OFF/AUTO; the Room ID scrolls across the LCD, then the first digit (HI) appears
 - Use the UP/DOWN arrow to scroll to the first number of the Room ID entry from the commissioning list (HI values can be from 0 to 6)
 - Accept the HI number by pressing DISPLAY. The MED value will now show on the LCD
 - Enter the MED 2 digits in the same manner (value 0–99). LCD shows LO
 - Enter the LO 2-digit value (0–99). On pressing DISPLAY, the new rId will scroll across the LCD, then the e529.RF returns to the menu list
- **PAn**—The ID number of a network coordinating device, e.g., a B574, in a network bridge application. The number will be included on the commissioning list.

- Enter Service Mode if not already there
- Scroll to PAn and press OFF/AUTO
- Use the UP/DOWN arrows to find the PAN ID on the commissioning list
- Press DISPLAY. The e529.RF beeps to confirm the Pan ID value is stored, and the LCD returns to the menu list
- **rF**—Selects the RF channel for IRAS communication. The number will be included on the commissioning list.
 - Enter Service Mode if not already there
 - Scroll to rF and enter using OFF/AUTO
 - Use UP/DOWN to set the RF channel between 11 and 26
 - Press DISPLAY. The e529.RF beeps to confirm the value is stored and the LCD returns to menu
- **Adr**—Used to “teach” IRAS devices the unique identification information (e.g., Room ID, PAN ID, I/O map for a room) that binds them to a room or network.
 - Enter Service Mode if not already there
 - Scroll to Adr and enter using OFF/AUTO
 - Prepare the partner device to learn from the e529.RF
 - Scroll to the Address for the device to be taught (from the commissioning list)
 - Press DISPLAY. The unit will send the teach command on all RF channels (11–26), then the LCD displays the selected address
 - Accept in partner device

Note: When in Address mode, the FAN button can be used to Reset the target device.

- **Io**—Used to configure the Input/Output map of a partner device. [Note: Some INNCOM devices can have variable roles in a room, e.g., an S217 can be configured to control a light or a switch. The device roles are contained in the I/O map.]
 - Enter Service Mode if not already there
 - Scroll to Io and enter using OFF/AUTO
 - Prepare the partner device to learn from the e529.RF
 - Scroll to the Address for the device to be taught (from the commissioning list)
 - Press DISPLAY. The unit sends the I/O map out over all channels

Note: Whenever a device is taught information, it is important to verify that the instruction was received and accepted by “pinging” the device. See PnG below.

- **SEr**—In legacy (3G) e529s, configures CBL8 Partner (Server) devices (e.g., X07). The e529.RF will eventually be able to configure CBL32 devices (e.g., X47) from here. Press DISPLAY to write parameters; press FAN to execute them.
- **LoC**—Menu of local parameters. This menu is typically not used by Installation Technicians. The entry below is provided solely for informational purposes. The list of local parameters below will change and grow.
 - Enter Service Mode if not already there
 - Scroll to Loc and enter using OFF/AUTO. The LCD shows a “P” and a number for each parameter (0–255).

- Select a parameter; press OFF/AUTO again to get the value of the parameter
- P0, 1: Set Room ID (Room ID should be set using rld)
- P2, 3: Set PAN ID (set PAN ID using the PAN parameter). Not required for RF
- P4: Set the transmission (Tx) radio power. Tx may need to be boosted to meet local conditions.
- P5: Set the RF channel (set RF channel using the rF parameter)
- P6: Set the e529.RF local address (default is 13)
- P7: Set the P5 channel (default channel is 1)
- P8: Set P5 partner (default partner is e528.36_X529.RF)
- **run**—Selects built-in tests of the e529.RF
 - Enter Service Mode if not already there
 - Scroll to run and enter using OFF/AUTO.
 - Use the UP/DOWN arrows to select one of the following tests. Use the DISPLAY button to begin test
 - 1—Reset: On execution, the LCD screen flashes red, then briefly shows reset information from a bound device
 - 2—CI Connectivity test
 - 3—Broadcast Room ID, Network ID, and PAN ID to RF bridge device
 - 11—PIR test: On execution, the LCD shows Pir and the unit emits a loud noise when movement is detected by the passive infrared module.
 - 12—Door Test: On execution, the e529 responds with a beep when the door switch is actuated
 - 13—Window Test: On execution, the E529 responds with a beep when the window switch is actuated
 - 14—Remote PIR Test: On execution, the LCD shows Pir and the unit emits a noise when movement is detected by a remote device with a passive infrared module
 - 20—Reset counter: On execution, the LCD displays the number of times that the unit has been reset, then reverts to the test number
 - 23— Press DISPLAY to start a real-time temperature test. The Set temperature ticks up every second for one minute.
 - 24—Tests room relative humidity (if sensor available)
 - 25—Tests the built-in light sensor
 - 26—Tests battery power (255 = full charge)

- **PnG**—Sends a signal to connected devices and registers response
 - Enter Service Mode if not already there
 - Scroll to PnG
 - Scroll to the address of the device to be pinged. After 2 seconds, the version of the partner device will scroll across the LCD, verifying communication with the e529.RF

Note: Pressing DISPLAY after a device has been pinged allows entry into the NVRAM of partner devices. Activity in the NVRAM space can severely affect functionality. This parameter should be used only by INNCOM technicians.

Commissioning Process

As noted in the Application Overview, the e529.RF may be employed in 3 scenarios. For each scenario, establishing the unique room ID, binding devices, and establishing communication will be different. Some devices for instance, initiate binding (reverse bind) and some must be actively “taught” (forward bind). Consult the Commissioning instructions for the particular device. See also the e529.RF User Manual for detailed instructions.

Testing

Testing the e529.RF Operational Controls

The e529.RF and the other INNCOM devices in a room setup or network have been subjected to rigorous unit, integration, operational and production testing prior to shipment for installation. The installation technician needs only to test generally that the thermostat functions as intended.

1. At power ON, confirm all segments and characters are displayed on the LCD display.
2. Press the DISPLAY button to verify that the LCD briefly shows the Room (measured) temperature (which should be close to or equal the Set temperature). If the e529.RF is networked to an outdoor sensor, press DISPLAY again to check that outside temperature is displayed.
3. Press the °F/°C button once to verify that the temperature scale changes. Verify that the LCD resets to the default scale in 5 seconds.

4. Use the OFF/AUTO button to test Heat/Cool functions (depending on the HVAC system, fan operation may only subside to a minimal level). Press OFF/AUTO to return to Auto mode. Press the FAN button to cycle fan speed from LO to MED to HI. Press the ecoMODE™ button. Verify that the LCD displays notification that the ecoMODE option has been chosen.
 5. Test the PIR by entering the Run menu and selecting Value 11. On execution, the LCD shows Pir and the unit emits a buzzing noise when movement is detected by the passive infrared module.
 6. Test the door monitor by entering the Run menu and selecting value 12.
 7. If balcony door or window sensors are linked to the e529.RF, open the linked opening. Verify that the e529.RF displays notification that the door or window is open.
- Consult the dealer or experienced radio/TV technician for help

Testing e529.RF IRAS and RF network connections

1. Use the PING parameter to test each device on the network.
2. Verify that e529.RF LCD displays a dot in lower right corner of the screen indicating RF link to HVAC partner.
3. Enter the RUN menu value 2. Execute a test of the IWAN. If the test is successful, the Room ID will scroll across the LCD, indicating communication with the server.

FCC Statement

This equipment has been tested and found to comply with the limits for Class B digital device, pursuant of part 15 of the FCC Rules. These limits are designed to provide reasonable protection against harmful interference in a residential installation. This equipment generates, uses and can radiate radio frequency energy and, if not installed and used in accordance with the guarantee that interference will not occur in a particular installation. If this equipment does cause harmful interference to radio or television reception, which can be determined by turning the equipment off and on, the user is encouraged to try to correct the interference by one or more of the following measures:

- Reorient or relocate the receiving antenna.
- Increase the separation between the equipment and receiver.
- Connect the equipment into an outlet on a circuit different from that to which the receiver is connected.

