

**ION<sup>®</sup>**

# **TOTAL PA GLOW**

iPA69C

**Quickstart Guide**



## Federal Communications Commission (FCC) Statement

This device complies with part 15 of the FCC Rules. Operation is subject to the following two conditions: (1) This device may not cause harmful interference, and (2) this device must accept any interference received, including interference that may cause undesired operation.

**Note:** This equipment has been tested and found to comply with the limits for a Class B digital device, pursuant to part 15 of the FCC Rules. These limits are designed to provide reasonable protection against harmful interference in a residential installation. This equipment generates, uses and can radiate radio frequency energy and, if not installed and used in accordance with the instructions, may cause harmful interference to radio communications. However, there is no guarantee that interference will not occur in a particular installation. If this equipment does cause harmful interference to radio or television reception, which can be determined by turning the equipment off and on, the user is encouraged to try to correct the interference by one or more of the following measures:

- Reorient or relocate the receiving antenna.
- Increase the separation between the equipment and receiver.
- Connect the equipment into an outlet on a circuit different from that to which the receiver is connected.
- Consult the dealer or an experienced radio/TV technician for help.

**Warning:** Changes or modifications made to this device not expressly approved by ION Audio, LLC may void the FCC authorization to operate this device.

**Note:** The manufacturer is not responsible for any radio or TV interference caused by unauthorized modifications to this equipment. Such modifications could void the user's authority to operate the equipment.

**IC Statement:** This device complies with Industry Canada licence-exempt RSS standard(s). Operation is subject to the following two conditions: (1) this device may not cause interference, and (2) this device must accept any interference, including interference that may cause undesired operation of the device.

Le présent appareil est conforme aux CNR d'Industrie Canada applicables aux appareils radio exempts de licence. L'exploitation est autorisée aux deux conditions suivantes : (1) l'appareil ne doit pas produire de brouillage, et (2) l'utilisateur de l'appareil doit accepter tout brouillage radioélectrique subi, même si le brouillage est susceptible d'en compromettre le fonctionnement.

## Quickstart Guide (English)

### Introduction

1. Make sure all items listed in the **Box Contents** are included in the box. Look in the box under the foam sheet for the speaker stand rubber feet, speaker stand mounting knob, power cable, and microphone.
2. **Read the safety instruction booklet before using the product.**
3. Study the **Connection Diagram**.
4. Make sure all input devices such as microphones, CD players, or digital media players are turned off and volume settings are set at “zero.”
5. Connect all devices as shown.
6. Switch everything on in the following order:
  - audio input sources (i.e. microphones, instruments, CD players)
  - Total PA Glow
7. When turning off, always reverse this operation:
  - Total PA Glow
  - any input devices

### Box Contents

Total PA Glow

Microphone with Cable

Telescoping Speaker Stand

Remote Control

Power Cable (IEC)

Quickstart Guide

Safety Instructions & Warranty Information Booklet

### Support

For the latest information about this product (system requirements, compatibility information, etc.) and product registration, visit [ionaudio.com](http://ionaudio.com).

For additional product support, visit [ionaudio.com/support](http://ionaudio.com/support).



**Caution:** Do not expose Total PA Glow to rain or standing water.

**Quick Setup**

**Connection Diagram**

Items not listed under **Introduction > Box Contents** are sold separately.

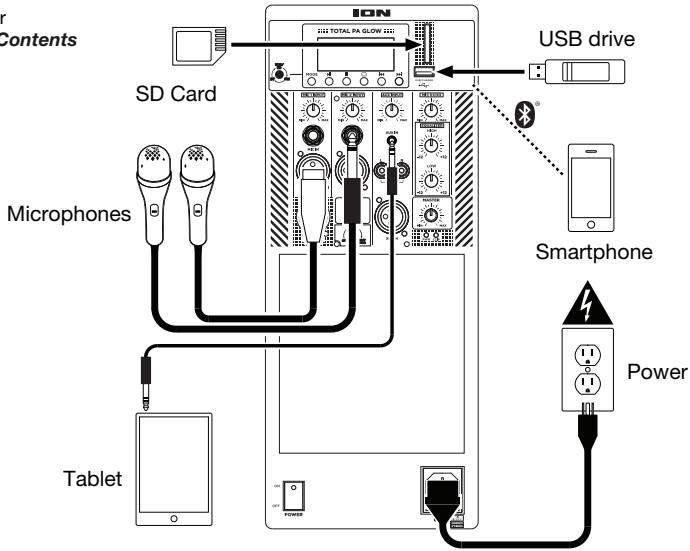

**Speaker Stand Installation**

1. Fully extend the speaker stand tripod legs on a flat, stable surface. Look in the box contents under the foam sheet for the rubber feet and speaker stand mounting knob.
2. Raise the mounting pole up to the appropriate height needed and tighten the side adjustment knob.
3. Insert the pin into the bottom pin-hole so the mounting pole stays at your set height.
4. On Total PA Glow, adjust the bottom knob counter-clockwise so the screw is not blocking the opening.
5. Line up the Total PA Glow mounting hole with the speaker stand pole and place on the pole.
6. Tighten the mounting knob clockwise on Total PA Glow.

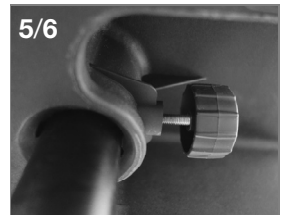
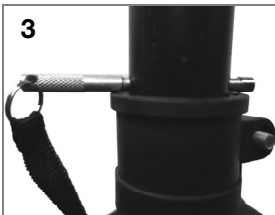

## Features

### Rear Panel

- Media Panel:** Controls for the USB, SD, FM radio (*if applicable*), and Bluetooth sources. The Media Panel Mode source symbol will illuminate when that source is playing.
- USB Port:** Connect your USB flash drive here to play music.
- SD Card Slot:** Insert your SD card here to play music.
- Display:** Displays the media panel modes for USB, SD, FM radio (*if applicable*), and Bluetooth.
 

**Note:** The display comes with a plastic protector on it. Remove this for optimal viewing.
- Mic Inputs (1/4"/6.35 mm & XLR):** Connect a dynamic microphone to the 1/4" (6.35 mm) or XLR inputs. Control the volume of the inputs using the **Mic Input Volume** knobs.
- Mic Input Volume:** Turn this knob to adjust the input volume of the **Mic Input**.
- Aux Input (1/8"/3.5 mm):** Connect a CD player, digital media player, or other audio source to this 1/8" (3.5 mm) stereo auxiliary input. Control the volume using the **Aux Input Volume** knob.
- XLR Input (XLR):** Connect a line-level mixer or musical instrument to this XLR line-level input. Control the volume using the **Aux Input Volume** knob. Use this line-level input when linking together two Total PA Glow units.
- RCA Inputs:** Connect a CD player, digital media player, mixer, or other media source to these inputs. Control the volume using the **Aux Input Volume** knob.
- Aux Input Volume:** Turn this knob to adjust the input volume of the **Aux Input**, **XLR Input**, and **RCA Inputs**.
- Mix Out (XLR):** Connect this XLR output to another active (powered) speaker. The level of the output is controlled by the **Mic Input Volume**, **Aux Input Volume**, and **Master Volume**.
- Mic Echo:** Use this knob to add or remove an echo effect to the **Mic Inputs**.
- High EQ:** Increases or decreases the high (treble) frequencies for **Mic Input**, **Line Input**, and **Media Panel** sources at a range between -12 dB to +12 dB.
- Low EQ:** Increases or decreases the low (bass) frequencies for **Mic Input**, **Line Input**, and **Media Panel** sources at a range between -12 dB to +12 dB.
- Master Volume:** Turn this knob to adjust the overall output volume of the loudspeaker.

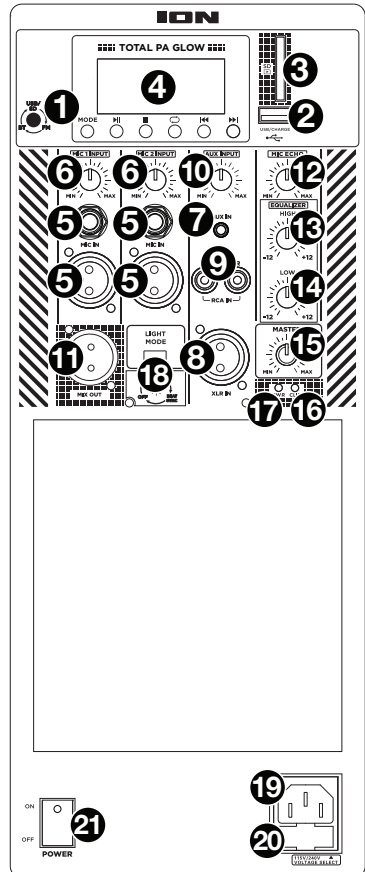



16. **Clip LED:** This LED will flash red if the signal from the inputs or media panel source is clipping. If this happens, decrease the setting of the **Mic Input Volume** knob, **Aux Input Volume** knob, or **Master Volume** knob.
17. **Power LED:** Indicates whether Total PA Glow is powered on or off.
18. **Light Mode Button:** Press this button to select how the lights on the front panel function:
  - **Color Cycle:** The lights slowly glow and cycle through colors. Press and hold the light mode button to freeze the lights on one color. This is the default mode when Total PA Glow is first powered on.
  - **Beat Sync:** The lights react to the beat of the music.
  - **Off:** The lights turn off.
19. **Power Cable Input (IEC):** Insert the included power cable here to power the unit.
20. **Fuse:** The orientation of the fuse holder determines the current voltage setting of Total PA Glow. The current setting is shown above the white triangle ( $\Delta$ ): **110–120 V** or **220–240 V**. If you use Total PA Glow in a region with a different voltage, change the voltage setting by removing the fuse holder, inverting it, and reinserting it.  
  
If the unit's fuse is broken, remove the fuse holder and replace the broken fuse with one with the same rating (printed on the fuse holder). Using a fuse with an incorrect rating can damage the unit and/or fuse.
21. **Power Switch:** Turns Total PA Glow on or off.

## Media Panel

### Media Panel Functions:



**MODE Mode:** Switches modes from USB, SD, FM radio (*if applicable*), or Bluetooth.

 **Play/Pause:** Play/pause the USB, SD, or Bluetooth source. Press and hold **Play/Pause** for 2 seconds to begin the preset auto-store function (*if applicable*). This jumps to the lowest station (87.5) and then travels through the bandwidth to auto-store the strongest stations as presets.

 **Repeat:** Repeat all of the tracks (**ALL**), repeat all of the tracks in the folder (**FOLD**), repeat the current playing USB or SD track (**OnE**), or shuffle the track order (**rAn**).

 **Previous:** Plays the previous USB, SD, or Bluetooth track. When listening to the FM radio (*if applicable*), press the button once to skip back through the FM stations and hold the button down to seek back through the channel presets.

 **Next:** Plays the next USB, SD, or Bluetooth track. When listening to the FM radio (*if applicable*), press the button once to tune the radio down one preset and hold the button down to seek forward through the channel presets.

**Note:** In some apps, pressing the **Previous** () or **Next** () buttons may go to another playlist or music genre.

## Media Panel Remote

**Note:** Aim the remote straight at the front of the speaker woofer. Room lighting and battery life can affect the operating range of the remote control.

**Note:** In order to use the remote control for the first time, first pull out the tab attached to the battery compartment. To change the remote battery, follow the diagram located on the back of the remote. Use a 3 V DC CR2032 lithium button cell battery for replacement.

1. **Stop:** Stops the media panel source from playing.
2. **Mode:** Selects the media panel source: USB, SD, FM radio (*if applicable*), or Bluetooth.
3. **Mute:** Silences the music playback on media panel sources.
4. **Prev (◀◀):** Goes to the previous USB or SD card track. When listening to Bluetooth sources, pressing **Prev** in some apps may go to another playlist or music genre. When listening to the FM radio (*if applicable*), press the **Prev** button once to skip back through the FM stations and hold the button down to seek back through the channel presets.
5. **Next (▶▶):** Advances to the next USB or SD card track. When listening to Bluetooth sources, pressing **Next** in some apps may go to another playlist or music genre. When listening to the FM radio (*if applicable*), press the **Next** button once to tune the radio down one preset and hold the button down to seek forward through the channel presets.
6. **Play/Pause (▶||):** Plays or pauses the USB, SD, or Bluetooth media panel source. Press and hold **Play/Pause** for 2 seconds to begin the preset auto-store function (*if applicable*). This jumps to the lowest station (87.5) and then travels through the FM band to auto-store the strongest stations as presets.

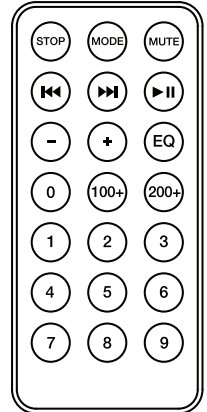

**Note:** Files are played from the USB or SD source first by alphabetical order of what is on the root level, then alphabetical by folder, and then alphabetical by the track name.

7. **Vol -:** Decreases the media panel source volume.
8. **Vol +:** Increases the media panel source volume.
 

**Note:** The remote volume only affects the media panel source and works together with the physical media panel volume knob on the unit's rear panel.
9. **EQ:** Selects one of the following digital EQ presets to use with a media panel source: Bass (**BAS**), Pop (**POP**), Rock (**ROC**), Jazz (**JA2**), Classical (**CLA**), Country (**COU**), No EQ (**OFF**, factory default setting).
 

**Note:** The digital EQ only works for Bluetooth, USB flash drive, and SD card sources.
10. **100+:** Jumps ahead by 100 tracks.
11. **200+:** Jumps ahead by 200 tracks.
12. **Number Keys:** Provides channel selection for FM radio stations (*if applicable*), and track selection for USB and SD card sources.

## Operation

### Pairing a Bluetooth Device

1. Turn on your Bluetooth device.
2. Power on Total PA Glow.
3. Use the **Mode** button to select Bluetooth mode, which appears as "bt" in the display. Total PA Glow will automatically go into pairing mode to search for Bluetooth devices. You will know you are in pairing mode when the Bluetooth icon is flashing.
4. Navigate to your Bluetooth device's setup screen, find **Total PA Glow**, and connect. The **Bluetooth icon** will remain solidly lit.

**Note:** Users should consider updating their device's OS if experiencing trouble with pairing or playing music.

5. To disconnect pairing, turn off Bluetooth on your device or select **Forget this device** from your device.

### Troubleshooting

**If the sound is distorted:** Try lowering the volume control of your sound source or musical instrument. Also, try to reduce the overall volume of Total PA Glow.

**If there is too much bass:** Try adjusting the tone or EQ control from Total PA Glow or your sound source to lower the bass level. This will allow you to play the music louder before clipping (distortion) occurs.

**If there is a high-pitched whistling noise when using a microphone:** This is probably feedback. Point the microphone away from the speaker.

**If you can't hear the microphone over the music volume:** Turn down the music volume from your source.

**When I press Previous (◀◀) or Next (▶▶), it doesn't increment to the next FM station:** Short presses of the button will jump to presets. Hold the button down to **seek** to the next station. *(If applicable)*

**If the radio station channel is flashing:** The unit is currently muted. Unmute to stop the flashing and resume playback.

**If the Bluetooth logo is flashing rapidly:** The unit is currently in pairing mode.

**If the Bluetooth logo is flashing slowly:** A device is paired, but the music is muted. Unmute to stop the flashing and resume playback.

**The USB track number (Example: 001) is flashing slowly:** The USB drive music playback is muted. Unmute to stop the flashing and resume playback.

**The LCD shows "NONE":** The unit is in USB/SD mode, but there is no USB drive attached or no SD card inserted.