



***IP*Series**

B32450-25 Base Station Product Owner's Manual

Date Released: January 23, 2004

Document #: 516-80520-POM
Version: A

Copyright 2004 IPMobileNet, Inc.

16842 Von Karman Avenue, Suite 200 ☐ Irvine, CA 92606
Voice: (949) 417-4590 ☎ Fax: (949) 417-4591

The term "IC": before the radio certification number only signifies that Industry of Canada technical specifications were met.

Operation is subject to the following two (2) conditions: (1) this device may not cause interference, and (2) this device must accept any interference, including interference that may cause undesired operation of this device.

The following U.S. Patents apply to this product:

U.S. Patent numbers 5,640,695,6,018,647,6,243,393

Information contained in this document is subject to change without notice.

All rights reserved. Reproductions, adaptations, or translation without prior written permission is prohibited, except as allowed under copyright laws.

SECTION 1: THEORY OF OPERATION	4
General Block Diagram	4
<u>General Block Diagram Definitions</u>	4
Input/Output	4
System Controller.....	4
<u>Modems</u>	5
<u>Diversity Reception</u>	5
RX Injection.....	5
Transmitter	5
Receiver 1/ 2/ 3.....	5
Power Supply	5
B32450-25 Base Station Section Descriptions	6
System Controller.....	6
Input/Output	6
Modem Switching.....	6
Modem	7
Receive Signal Strength Indication Comparator.....	7
Baseband	8
Receiver Board	8
IF Amplifier	8
Receiver Injection.....	9
Exciter Board.....	9
Analog Modulation	10
Phase Locked Loop	10
Power Amplifier	11
SECTION 2: FACTORY TEST PROCEDURE	12
Equipment List	12
Programming and Configuring the Base Station	13
Adjustment / Alignment Procedure	14
Receiver Injection.....	14
Receiver	14
Diversity Reception	15
Receive Data.....	16
Exciter	17
Power Amplifier	17
SECTION 3: FCC LABEL	18
B32450-25 Base Station FCC Label Placement	18
B32450-25 Base Station FCC Label	18
APPENDIX A: B32450-25 CIRCUIT BOARD DIAGRAM	19
APPENDIX B: B32450-25 TEST DATA SHEET	23

GENERAL BLOCK DIAGRAM

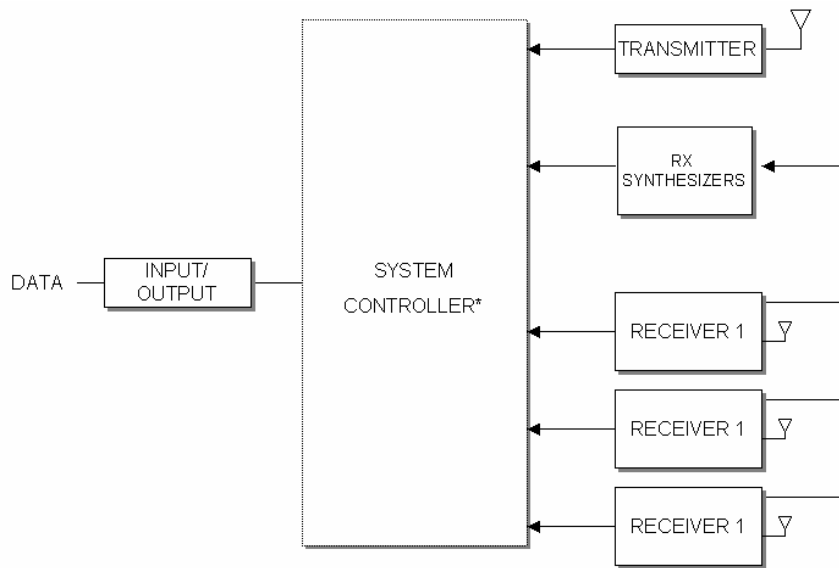

*System Controller houses modem, diversity, Ethernet, and transmit processing

General Block Diagram Definitions



For increased data security, the modem supports the U.S. Government developed Digital Encryption Standard (DES) data encryption and decryption protocols. This capability requires installation of third-party IP compliant DES encryption and decryption software.

The standard *IP*Series base station circuit board contains five (5) main sections defined below:

Input/Output

Circuitry associated with one of the following base station's data connectors:

- RS232 Serial Port DB9 Data Connector
- RJ45 Ethernet 10 Base T Interface Connection

System Controller

Houses the modem, diversity, and Ethernet circuitry. Manages the operation of the base station's modem providing transmit timeout protection in the event a fault causes the base station to become halted in the transmit mode. The system controller also handles the loading of selected transmit and receive frequencies into the injection synthesizer. Includes memory for storage through Electrically Erasable Programmable Read Only Memory (EEPROM) of the base station's operating parameters, which are retained after the base stations power is cycled off.

<u>Modems</u>	Convert data into an analog audio waveform for transmission and analog audio from the receiver to serial data interface. There is one (1) modem that is dedicated to the transmit operation and two (2) modems dedicated to the receive operation. The modem dedicated to transmitting supports a 115.2 KBPS data transmission rate on the serial port, SLIP protocol, and a 32 KBPS over-the-air data transmission rate. Provides Forward Error Correction (FEC) and Error Detection (CRC), bit interleaving for more robust data communications, and third generation collision detection and correction capabilities.
<u>Diversity Reception</u>	Circuitry selects one of three (3) diversity receiver audio outputs for processing by the modem by comparing the Received Signal Strength Indication (RSSI) output from each receiver. Audio from the receiver with the highest RSSI value is passed to the modems.
RX Injection	The Injection Synthesizer board provides a highly stable local oscillator signal for the three (3) receivers. This displays a serial data input/output interface, synthesizer, and VCO.
Transmitter	Consists of an exciter and a power amplifier module covering various frequency bands in segments. A different power amplifier module is required for each segment. The transmitter power control is included with the power supply circuitry on the same board.
Receiver 1/Receiver 2/ Receiver 3	Uses three (3) discrete receivers tuned to the same frequency. The three (3) receivers are required to support <i>IPMobileNet</i> 's base station Diversity Reception System (DRS). NOTE: Some installations use only two (2) receivers. The receivers are double-conversion superhetrodynes with an Intermediate Frequency (IF) of 45 MHz. Each receiver consist of bandpass filters, RF amplifiers, a mixer, 45 MHz crystal filter, and a one-chip IF system. The injection synthesizer provides the first local oscillator signal and outputs from each receiver including RSSI and analog audio for Diversity Reception.
Power Supply	Power supply circuitry derives the various operating voltages required by the base station. Fixed voltage regulators are employed through the base station for this purpose.

B32450-25 Base Station Section Descriptions

System Controller

This section displays the Central Processing Unit (CPU)(U1), clock, and power-on reset circuitry. It provides more processing power than required for future capabilities to be incorporated without changing processors. Such capabilities include data encryption/decryption (DES) and remote fault monitoring. U1 features a 16-bit address bus and 128K of internal flash random access memory (RAM).

NOTE: To enter the programming mode it is necessary to reset the switch (S1) and power up again.

CPU operations are controlled by Y3 an 18.432 MHz clock module. Capacitor (C1) and an internal Schmidt trigger circuit inside of U1 generates the power on reset signal. The RESET* output from U1 drives a latch and decoder found elsewhere on the board.

This section displays the RAM, decoder, EEPROM, and programming power supply circuitry. U2 is a 512K x 8 bit static RAM chip, which provides temporary storage of base station configuration data while the power is on. This is necessary in order to program the base station. U2 is controlled directly by the address, data, and control busses from the CPU.

Chip U5 decodes the A11-A14 address bus to provide chip selects for the modem and EEPROM memory. Chip U6 is an 8-bit latch. It latches inputs from the D0-D7 bus and lights the front panel status indicators (*TX, CD, RX1, RX2, and RX3*).

Chip U3 is a serial EEPROM, which provides 2K bits of pre-programmed data storage for the CPU. Data is clocked out of U3 by EECLK, and back into the CPU via EEDATA.

A programming power supply is required for the flash RAM inside of the CPU, and this function is performed by U4. This chip is a low dropout voltage regulator with a shutdown control. Resistors R22 and R21 set the output voltage. When the base station configuration data is to be stored in flash RAM, the CPU makes VPP_ENABLE high. This turns on the regulator, producing a 12-volt output via VPP for the flash RAM.

This section displays a dedicated processor and voltage regulator. Chip U7 is a processor, which permits manual keyboard operation of the base station. Regulator VR2 provides 5 volts DC power for all logic circuitry on the System Controller Board.

Input/Output

This section displays the CPU input/output circuitry. Chip U8 is an RS232 transceiver, which interfaces the CPU to the modem via J1. From there, the RS232 data goes directly to a rear panel DB9 connector. U8 converts 5-volt logic-level data to +/-12 volt data in RS232C form, and vice-versa. A charge pump power supply on the chip converts the +5 volt DC power to the +/-12 volt levels required. The charge pump uses capacitors (C28 to C31) to generate voltages.

NOTE: The RS232 serial port data transmission rate of the base station is 115.2 KBPS.

Modem Switching

This section displays the connector wiring and modem switching circuitry. Connector J7 is routed to the front-panel TX, CD, and RX1-RX3 LED indicators. The base station will also accept modulation from an external source (modem or amplified microphone audio). Transmission gate U10A switches this signal source.

Modem

This base station uses separate modems for receive and transmit functions so that full-duplex operation may be obtained. The A0-A1 address bus in addition to the individual read (RD*), write (WR*), and chip select (MODEMTXCS*) lines control all three (3) modems. Modem operations are timed by Y2, a 4.9152 MHz clock module.

Modem chip U14 is dedicated to the transmit operation. Data from the D0-D7 bus is read by the chip, and then converted to a 4-level FSK analog signal, which appears on the TXOUT pin. Op amp U21B buffers the signal, which becomes the MODEM_TXMOD output. From this point, the signal is routed to the modulation circuitry on the Exciter Board.

Chip U14 has the ability to demodulate receiver audio, although this capability is not used in most systems. Incoming data-bearing audio from the Diversity Reception circuitry (and selected receiver) appears at DISC_AUDIO. The signal passes through resistor R54 and into the modem chip. Resistor R52 and capacitor C41 serve as feedback elements, limiting both the gain and bandwidth of an amplifier within U14. The modem chip demodulates the audio into 8-bits of data, which exit U14 on the D0-D7 bus.

Chip U14 also provides a bias voltage for the analog circuitry on the Exciter Board. This voltage is about 2.5 volts DC, and it appears on the VBIAS line. The purpose of VBIAS is to bias the Exciter Board analog circuitry for proper operation. Please note that if this voltage is low or missing, the Exciter Board circuitry may not work.

Modem chip U15 is dedicated to the receive operation. Incoming data-bearing audio from the Diversity Reception circuitry (and selected receiver) appears at DISC_AUDIO. The signal passes through resistor R56 and into the modem chip. Resistor R55 and capacitor C46 serve as feedback elements, limiting both the gain and bandwidth of an amplifier within U15. The modem chip breaks down the audio into 8 bits of data, which exit U15 on the D0-D7 bus.

Modem chip U16 is also dedicated to the receive operation, although it may not be used in this application. The operation of U16 is exactly the same as U15.

Receive Signal Strength Indication Comparator

This section displays the RSSI comparator circuitry. A series of comparators (U20BCD) simultaneously compare RSSI1 to RSSI2, RSSI2 to RSSI3, and RSSI1 to RSSI3. Within this process eight (8) possible results are then forwarded by the comparators to a series of NAND gates (U18ABC), which reduce the number of results to three (3) and translates the results for an analog multiplexer (U19A). To determine which of the three (3) results is the strongest, the following needs to occur:

- ❑ For Receiver 1 to be selected as the strongest signal, both input pins on the NAND gate (U18D) must go high (driving pin 7 of U19A). If Receiver 1 has the strongest signal, a light emitting diode (LED)(D1) lights indicating Receiver 1 was selected.
- ❑ For Receiver 2 to be selected as the strongest signal, the inverter (U17B) must go high (driving pin 6 of U19A). If Receiver 2 has the strongest signal, D2 lights indicating Receiver 2 was selected.
- ❑ For Receiver 3 to be selected the strongest signal, the inverter (U17C) must go high (driving pin 5 of U19A). If Receiver 3 has the strongest signal, D3 lights indicating Receiver 3 was selected.

SEL_RSSI is the output selected with the strongest signal. When RSSI voltage exceeds a threshold, another LED (D4) lights. As the other three (3) LEDs, this circuit is intended as a diagnostic tool. It provides a go/no go indication that an RF signal has been received. A pot (R74) sets the turn-on voltage.

Baseband

This circuitry amplifies the audio from each receiver, routes it through a RF multiplexer, and selects the audio from the receiver with the highest RSSI value. The comparator circuit on the previous sheet controls it.

There are three (3) channels of audio, with separate gain and DC offset adjustments to compensate for performance differences in the receivers. For example, incoming audio from receiver 1 appears at AUDIO 1. An op amp (U12D) is then amplifies the audio. A pot (R72) adjusts the gain, while another pot (R57) adjusts the DC offset on the output. The amplifier output passes through a RF multiplexer (U19B), then drives a low pass filter (U9) through another op amp (U12A) and through the AUDIO_OUT line, which goes to a switch (S3) and to pin 4 of a connector (J3).

The remaining audio circuits work in the same manner.

The output from U19B also appears on DISC_AUDIO, which goes to the CPU (U1) and from there the audio is demodulated by the modems.

Receiver Board



Please be aware that the base station uses three (3) identical receiver boards. As a result, the circuitry will be described only once.

Front end. Incoming signals pass through a bandpass filter (FLT4). The desired signals are amplified by U8 and additional selectivity is provided by a monolithic bandpass filter (FLT5). Another amplifier (U7) further amplifies the signal and the output pass through two (2) crystal filters (FLT2 and FLT3).

IF Amplifier

The incoming 45 MHz signal passes through C17, C18, and R28 which provides impedance matching to the IF amplifier input. U6 is a super heterodyne IF subsystem. Inside the chip, the signal is applied to a mixer. The mixer also accepts a 44.545 MHz local oscillator input. The local oscillator consists of an internal amplifier, plus crystal (Y4) and associated components. The mixer output passes through Y3, a 455 KHz ceramic IF filter. It is amplified, passed through ceramic filter (Y2), and on to a second IF stage. The IF output drives a quadrature detector. The phase shift elements for the detector are C20 and FLT1. The recovered audio appears at pin 9, while RSSI appears at pin 7.

Within the RSSI circuitry, chip U6 uses a detector, which converts the AGC voltage generated inside the chip into a DC level corresponding logarithmically to signal strength. RSSI is used by Diversity Reception on the System Controller to select the receiver with the highest quality signal.

A filter consisting of a resistor (R21) and a capacitor (C40) provides high frequency de-emphasis for the audio. The audio is buffered by op amp U3A. From there the AUDIO output line goes to a connector, for hookup to Diversity Reception on the System Controller Board.

Resistor (R22) and capacitor (C41) provides RF filtering for the DC RSSI voltage. The RSSI is buffered by op amp U3B. From there the RSSI output line goes to a connector, for hookup to Diversity Reception on the System Controller Board.



Several sets of 455 KHz IF filters (Y3 and Y2) are available to suit receiver selectivity requirements. Should replacement of these filters be required, exact replacement parts must be used.

Receiver Injection

This displays a serial data input/output interface, synthesizer, and VCO. The I/O interface circuitry accepts clock, serial data, and enable signals from the System Controller Board via terminal block TB1. A lock detect (LD) status output is returned to the System Controller Board from the synthesizer. U3 is a hex Schmidt Trigger inverter, which squares up incoming signals for reliable operation of the synthesizer chip. This is necessary because of a cable run between the two (2) boards.

The main section of this board is synthesizer chip (U2). The device contains the key components of a phase locked loop (PLL), including a 1.1 GHz prescaler, programmable divider, and phase detector. In operation, the desired frequency is loaded into U2 as a clocked serial bit stream via the CLK and DATA/I inputs. The lock detection circuitry consists of inverters U3E/U3F, diode CR3, and resistor R5. When the synthesizer is in lock, the LD pin on U2 is high, making the LD output on terminal block TB1 high. The EXC LD input on TB1 routes the lock detect output from the Exciter Board through diode CR3, and out through LD. This configuration tells the CPU on the System Controller Board that it is acceptable to process received data, or to key the transmitter when LD is high. Otherwise, if a fault in either synthesizer prevents a lock, receive and transmit operation will be inhibited.

Other items of interest include a programming switch and serial data output. Switch (JMP1) may be used to program the firmware configuration inside chip U2. The system controller board performs programming so a jumper is installed in the LNVCC (operation) position instead. The EXT DATA output on block TB1 sends frequency programming data to the transmitter synthesizer on the Exciter Board.

The UHF injection signal is generated by module VCO1. This device is a wide-range voltage controlled oscillator (VCO). A voltage on the VT input determines the VCO frequency. The voltage is generated by the phase detector output (PD/O) of U2, which drives a loop filter consisting of R4, C19, C20, R21 and C10. The filter integrates the pulses, which normally appear on PD/O into a smooth DC control signal for the VCO. The output of VCO1 is attenuated by module AT1, resulting in improved VCO stability.

This section displays the DC power supplies, frequency reference, and RF output circuitry. Regulator VR1 provides 9 volts DC for VCO module VCO1, and RF amplifier (U7). Regulator (VR2) provides a low noise 5-volt DC output for inverter (U3), synthesizer (U2), and reference (Y1).

Reference module (Y1) provides a high-stability 10 MHz reference frequency. Y1 is a voltage controlled, temperature controlled crystal oscillator (VCTCXO). This device also has a VC input which accepts a control voltage from pot R23. The pot permits a slight shift in the reference frequency which enables the three (3) receivers to be tuned precisely to the assigned receive frequency. A diode (CR2) provides additional voltage regulation, improving the frequency stability of reference Y1.

The RF output circuitry consists of RF amplifier (U7), and power splitters (U8, U5, and U6). U7 increases the signal level to correct for losses in the splitters. The splitter U8 provides two (2) RF outputs. One output drives splitter U5, which provides local oscillator injection for receivers 2 and 3. The other output drives splitter (U6), which drives receiver 1 and the PLL_FEEDBACK input on chip U2.

Exciter Board

This section displays the input/output interface, transmitter keying, and power supply circuitry. The input/output interface is built around terminal block (TB1) and Schmidt Trigger inverters (U7). Incoming clock, serial data, and chip select signals on block TB1 are squared up by U7. Then they are sent to the appropriate inputs on the transmitter synthesizer (U2). The EXCDATA source comes from the receive synthesizer on the Injection Synthesizer Board. A Schmidt Trigger chip is used here because of a cable run to the System Controller Board. The synthesizer returns a lock detect output to the Injection Synthesizer Board via U6 and EXCLD.

A regulator (VR2) powers the T/R switch circuitry. When the System Controller Board makes TXKEY* low, inverter U6D goes high, turning on transistor Q2 and FET Q1. This applies 5-volt power to the TXENABLE output, turning on the T/R switch on the Power Amplifier Board. At the same time, transistor Q3 conducts, grounding the KEY* input of the Power Amplifier Board. Finally, inverter U6C goes high and turns on RF switch U1, connecting the VCO output to the Power Amplifier Board for transmission.

The power supply consists of two (2) voltage regulators. A regulator (VR1) provides 9-volt power for the VCO. Another regulator (U11) provides low noise 5-volt power for the logic circuitry, synthesizer chip, and analog circuitry.

Analog Modulation

This section displays the analog modulation circuitry. Incoming modem audio from the System Controller Board appears at TXMOD, and is buffered by op amp U5C. If an external modulation source (modem or amplified microphone) is connected to the base station's DB9 connector, audio appears at EXTMOD. From there the audio passes through low pass filter U10. The audio is inverted and amplified by an op amp (U5D). It then passes on to the VCO module via VCOMOD. Pot R42 adjusts the level to suit the VCO.

The 10 MHz reference is also modulated in order to counteract the corrective effects of the synthesizer loop circuitry. For example, if only the VCO were modulated, the synthesizer would try to compensate for the frequency "error," caused by the modulation. This effectively reduces the amount of modulation available. Modulating the reference *and* the VCO simultaneously deceives the loop into not compensating for the modulation, because when the reference frequency goes high, the VCO frequency goes high, and vice-versa.

An op amp (U9A) amplifies the AUDIO output from another op amp (U5D) and applies it to jumper block JMP1. Pot R30 adjusts the gain of U9A. Op amp (U9B) inverts the phase of the audio and applies it to the other side of jumper block JMP1. The purpose of the jumper block is to select the proper phase of the audio. If the wrong phase is used, on modulation peaks the reference will swing in the same direction as the VCO, canceling out most of the modulation. The output from the jumper block goes to the 10 MHz reference via REFMOD.

The VBIAS input is a 2.5-volt DC source, which biases the op amps to the correct operating point. It is generated by modem chip (U14) on the System Controller Board.

Phase Locked Loop

This section displays phase locked loop (PLL) circuitry. The 10-MHz reference (Y1), runs synthesizer (U2), which in turn controls VCO VCO1. The main section of this board is the synthesizer chip (U2). The device contains the key components of a PLL, including a 1.1 GHz prescaler, programmable divider, and phase detector.

In operation, the desired frequency is loaded into U2 as a clocked serial bit stream via the CLK and DATA inputs. The lock detection circuitry consists of inverters U6A and U6B, diode CR1, and resistor R1. When the synthesizer is in lock, the LD pin on U2 is high, making the EXCLD output on terminal block (TB1) high. The EXCLD output on TB1 routes the lock detect output from the Exciter Board. This configuration tells the CPU on the System Controller Board that it is acceptable to process received data, or to key the transmitter when LD is high. Otherwise, if a fault in either synthesizer prevents a lock, receive and transmit operation will be inhibited.

The switch (JMP1) is used to select the supply voltage to chip U2. The UHF injection signal is generated by module VCO1. This device is a wide-range voltage controlled oscillator (VCO). A voltage on the VT

input determines the VCO frequency. The voltage is generated by the phase detector output (PD/O) of U2, which drives a loop filter consisting of R19, C16, C17, and C47. The filter integrates the pulses, which normally appear on PDOOUT into a smooth DC control signal for the VCO. The output of VCO1 is attenuated by module AT2, resulting in improved VCO stability.

Amplifier U8 amplifies the signal and applies it to a splitter (U3). One output of U3 is connected to a switch (U1). U1 is enabled by signal TX when the transmitter is enabled. The other output of the splitter is connected through AT1 and provides feedback to U2.

Power Amplifier

The transmit injection signal from the RF injection section is applied to the high-powered linear amplifier (U1) one (1) watt amplifier. The signal is then routed to the final power amplifier boosting the output signal to 40 watts. The transmitter output power is controlled with R3. R3 controls the output voltage of an adjustable regulator (U3). The signal KEY* enables the regulator. The output of the amplifier is routed to transmit antenna port ANT (via SW1).

Equipment List

The following table lists the equipment required to perform the B32450-25 Base Station Factory Test Procedure.

CHECKLIST OF REQUIRED MATERIAL FOR PRELIMINARY TESTING OF THE <i>IP</i>Series BASE STATION		
NO.	REQUIRED TOOLS	<input checked="" type="checkbox"/>
1	Calibrated Base Station System – Consisting of the following components: (1) Appropriate version <i>IP</i> Series Base Station to be tested (2) Desktop or laptop computer configured as an Internet Protocol Network Controller (IPNC) (3) Corresponding <i>IP</i> Series Mobile Radio (If an B32450-25 base, use M32450-25 mobile) (4) Desktop or laptop computer with two (2) available serial ports and Microsoft Windows 95 or greater and <i>IP</i> MobileNet Dial-Up Networking, <i>IP</i> Message software (SLIP2IPMN.exe), and HyperTerminal for base station installed	<input type="checkbox"/>
2	Comm Test Set (HP 8920A or B)	<input type="checkbox"/>
3	High Frequency Probe (85024A)	<input type="checkbox"/>
4	Power Supply for 85024A Probe (HP1122A)	<input type="checkbox"/>
5	Four (4) Channel Scope (Tektronix TDS 460A)	<input type="checkbox"/>
6	General Purpose Scope Probe	<input type="checkbox"/>
7	Digital multi-meter Tektronix Fluke (DMM912 77)	<input type="checkbox"/>
8	DC power supply with ammeter, 13.8V, 12 amps or more (Astron VS12M or equivalent)	<input type="checkbox"/>
9	100-watt dummy load/attenuator (Pasternack PE7021-40 or equivalent)	<input type="checkbox"/>
10	Four (4) antennas (generic mag mounts) tuned to frequency or transceiver	<input type="checkbox"/>
11	Serial cable DB9M – DB9F connectors (generic)	<input type="checkbox"/>
12	Input/Output (I/O) Board (IPMN p/n: 502-80081)	<input type="checkbox"/>
13	<i>IP</i> Series Base Station power cable specified for use with the specific base station being used	<input type="checkbox"/>
14	Three (3) serial DB9F-DB9M Null Modem cables	<input type="checkbox"/>

Programming and Configuring the Base Station



This section applies to the 450 to 460 MHz frequency range of the *IP*Series Base Station. **Important!** The base station's IP address must be known prior to performing the procedures in this section.

The programming procedure should be performed when it is necessary to upgrade a base station's Firmware or to change the operating parameters to suit client needs.

Viewing the Base Station's Configuration Data

Step 1 At the HyperTerminal window, type in the appropriate password and press **[ENTER]**.

Step 2 Type **?** and press **[ENTER]**. The following example displays in the HyperTerminal window:

```

Host serial = 115200,N,8,1, timeout=200
Host framing = SLIP, no split frames no status messages
tunnel = 0
TX format = new
Injection = LOW SIDE, 45MHz
channel spacing = 25000
Channel = 0
      Channel   Tx freq   Rx freq   Inj freq
Frequency=0, 450.000000, 463.000000, 418.000000
Serial number: yyyyyyyy
RIM address = 1
Frequency group = 1
TX quiet time = 5
Symbol sync time = 12 milliseconds, 0 extra inter-split-frame count
TX tail time = 5
Radio data rate = 19200
Max data tx time = 60 seconds
Carrier detect delay time = 1 millisecond
Station ID = ABC123
Station ID time = 10 minutes
Polarity = TX+, RX+
Allow crc errors = 0
Suppress keep alive = 0
Allow base to base = 0
Timeslot status = 0
Duplicate time = 10 milliseconds
Control head grant delay = 50 milliseconds
RIM DD delay = 0 milliseconds
Retry interval = 0 milliseconds
Retry time limit = 0 milliseconds
RSSI step = 25 (=19dBm)
IPNC = 192.168.3.3
SLIP Address = 192.168.4.6
RF IP Address = 192.168.3.1
SNTP interval = 60 seconds
num timeslots = 16
timeslot period = 992ms
timeslots per voice packet = 4
noise = -128dBm
Fixed TX Delay = 0 milliseconds
Scale TX Delay = 0 microseconds
    
```

Adjustment / Alignment Procedures

Make appropriate notations of any items that require attention during this procedure. This information is needed later during the repair process.

Startup

- Step 1** Remove the base station cover placing the screws in a location where they will not be misplaced.
- Step 2** Connect the base station to the appropriate components.
- Step 3** Power up the base station and computer. The power supply ammeter must read 1.2 amps or less with a 13.8 VDC input.

Receiver Injection

- Step 1** Using the HP high frequency probe verify that the receiver injection frequency is present at each of the three (3) receivers by monitoring the receivers R24 surface mount pad which lies on the 50 ohm track between P1 and C43.
- Step 2** Adjust R23 on the receiver injection circuit board to set the injection frequency within 10 Hz of the exact injection frequency. The amplitude of the injection frequency should read approximately +5 dBm \pm 1 dBm.

Receiver

- Step 1** **Using the high frequency probe, monitor the 44.545 MHz second injection frequency** at U6 pin 3, adjust trimmer capacitor (C22) to the center of the oscillator's oscillation range. The amplitude level of pin 3 of U6 should read between +5 and +10 dBm.
- Step 2** Inject an on-frequency signal at a level of -80 dBm, modulated with a 1 KHz test tone at \pm 5.0 KHz deviation into the receiver under test.
- Step 3** Check the receiver's sensitivity, verifying that the SINAD is 12 dB or better at a maximum level of -119 dBm (-120 is typical).

Diversity Reception

- Step 1** Inject an on-frequency signal at a level equal to Receiver 1 12dB SINAD level, modulated with a 1 KHz test tone at ± 5.0 KHz deviation into Receiver 1.
- Step 2** While monitoring TP1 with the digital multi-meter, adjust RSSI1 low adjust potentiometer (R12) for a reading of 0.750 VDC ± 10 mV.
- Step 3** Increase the amplitude of the signal by 50 dBm.
- Step 4** While monitoring TP1 with the digital multi-meter, adjust RSSI1 high adjust potentiometer (R11) for a reading of 2.75 VDC ± 10 mV.



Adjustments R11 and R12 are interactive adjustments, therefore continue adjustments until the DC voltage at TP1 is 0.750 VDC for the receiver's 12 dB SINAD level and 2.75 VDC for a 50 dBm increase from the receiver's 12 dB SINAD level.

- Step 5** Inject an on-frequency signal at a level equal to Receiver 2 12dB SINAD level, modulated with a 1 KHz test tone at ± 5.0 KHz deviation into Receiver 2.
- Step 6** While monitoring TP2 with the digital multi-meter, adjust RSSI1 low adjust potentiometer (R10) for a reading of 0.750 VDC ± 10 mV.
- Step 7** Increase the amplitude of the signal by 50 dBm.
- Step 8** While monitoring TP2 with the digital multi-meter, adjust RSSI1 high adjust potentiometer (R9) for a reading of 2.75 VDC ± 10 mV.



Adjustments R9 and R10 are interactive adjustments, therefore continue adjustments until the DC voltage at TP2 is 0.750 VDC for the receiver's 12 dB SINAD level and 2.75 VDC for a 50 dBm increase from the receiver's 12 dB SINAD level.

- Step 9** Inject an on-frequency signal at a level equal to Receiver 3 12dB SINAD level, modulated with a 1 KHz test tone at ± 5.0 KHz deviation into Receiver 3.
- Step 10** While monitoring TP3 with the digital multi-meter, adjust RSSI1 low adjust potentiometer (R33) for a reading of 0.750 VDC ± 10 mV.
- Step 11** Increase the amplitude of the signal by 50 dBm.
- Step 12** While monitoring TP3 with the digital multi-meter, adjust RSSI1 high adjust potentiometer (R35) for a reading of 2.75 VDC ± 10 mV.



Adjustments R33 and R35 are interactive adjustments, therefore continue adjustments until the DC voltage at TP3 is 0.750 VDC for the receiver's 12 dB SINAD level and 2.75 VDC for a 50 dBm increase from the receiver's 12 dB SINAD level.

SECTION 2: FACTORY TEST PROCEDURE

Step 13 Inject on-frequency signal at a level of -80 dBm, modulated with a 1 KHz test tone at ± 5.0 KHz deviation into Receiver 1.

Step 14 While monitoring the AC voltage at TP6 adjust audio 1 AC adjustment potentiometer (R72) for 350 mVRMS (± 1 mV).

Step 15 While monitoring the DC voltage at TP6 adjust audio 1 DC adjustment potentiometer (R57) for 2.500 VDC (± 1 mV).



The audio AC and DC adjustments are interactive, therefore continue adjusting R72 for 350 mVRMS and R57 for 2.500 VDC until further adjustments are no longer required.

Step 16 Inject on-frequency signal at a level of -80 dBm, modulated with a 1 KHz test tone at ± 5.0 KHz deviation into Receiver 2.

Step 17 While monitoring the AC voltage at TP6 adjust audio 1 AC adjustment potentiometer (R71) for 350 mVRMS (± 1 mV).

Step 18 While monitoring the DC voltage at TP6 adjust audio 1 DC adjustment potentiometer (R58) for 2.500 VDC (± 1 mV).



The audio AC and DC adjustments are interactive, therefore continue adjusting R71 for 350 mVRMS and R58 for 2.500 VDC until further adjustments are no longer required.

Step 19 Inject on-frequency signal at a level of -80 dBm, modulated with a 1 KHz test tone at ± 5.0 KHz deviation into Receiver 3.

Step 20 While monitoring the AC voltage at TP6 adjust audio 1 AC adjustment potentiometer (R53) for 350 mVRMS (± 1 mV).

Step 21 While monitoring the DC voltage at TP6 adjust audio 1 DC adjustment potentiometer (R59) for 2.500 VDC (± 1 mV).



The audio AC and DC adjustments are interactive, therefore continue adjusting R53 for 350 mVRMS and R59 for 2.500 VDC until further adjustments are no longer required.

Step 22 Adjust the carrier detect potentiometer (R74) to illuminate a level of -116 dBm.

Receive Data

Step 1 Using a calibrated mobile radio, generate uplink data messages using the **X=1400,19** command in the *IPMessage Utility* program.

Step 2 Attach an antenna to one of the base station's receiver ports and verify on the base station monitor screen (HyperTerminal) that the received message data quality are consistently 240 and higher for 1400 character messages. Repeat test for each receiver.

Exciter

- Step 1** Using the **X=1400,19** command, generate data messages so the transmit power and frequency can be checked.
- Step 2** Note the power level and then on the power amplifier circuit board adjust the potentiometer (R3) fully counterclockwise (this will enable low power transmit operation).
- Step 3** Connect the base stations' transmit port to the HP communication test set.
- Step 4** While transmitting data messages using the **X=1400,19** command, adjust the following:
- TCXO Y1 for minimum frequency error
 - R42 for ± 5 KHz deviation



Transmit output power should be approximately 1mWatt. The REFMOD adjustment needs to be made while the base station is transmitting real data messages to and from a mobile radio. This is most easily done using the ping command to ping the IPNC from a mobile radio. This will cause the base station to repeatedly send data messages and will facilitate the REFMOD adjustment.

- Step 5** Connect the base station to the IPNC.
- Step 6** Using a calibrated mobile radio operating on the base station's channel, adjust R30 for consistent data quality readings of 248 (as observed on the mobile radio's attached PC *IPMessage* window). Access the MSDOS prompt and ping using the following command:

```
>ping 192.168.3.3 -t -l 500 -w 2000
```



This command will ping the IPNC continuously with a 500-character test message. Press **[Ctrl]+C** to stop the ping.

Power Amplifier

- Step 1** Connect the base station's transmit port to the communication test set.
- Step 2** Using the **X=1400,19** command, generate data messages.
- Step 3** Slowly increase the base station output power by turning the power control potentiometer clockwise until the power noted in Step 2.



Do not exceed 40 watts output power, as this will reduce the life of the amplifier module. If the base station uses a power amplifier, output power must be set to achieve power output specified for the specific base station installation.

- Step 4** Perform a close visual inspection of the base station paying close attention to manufacturing related problems such as loose screws, solder practices, etc.

B32450-25 Base Station FCC Label Placement

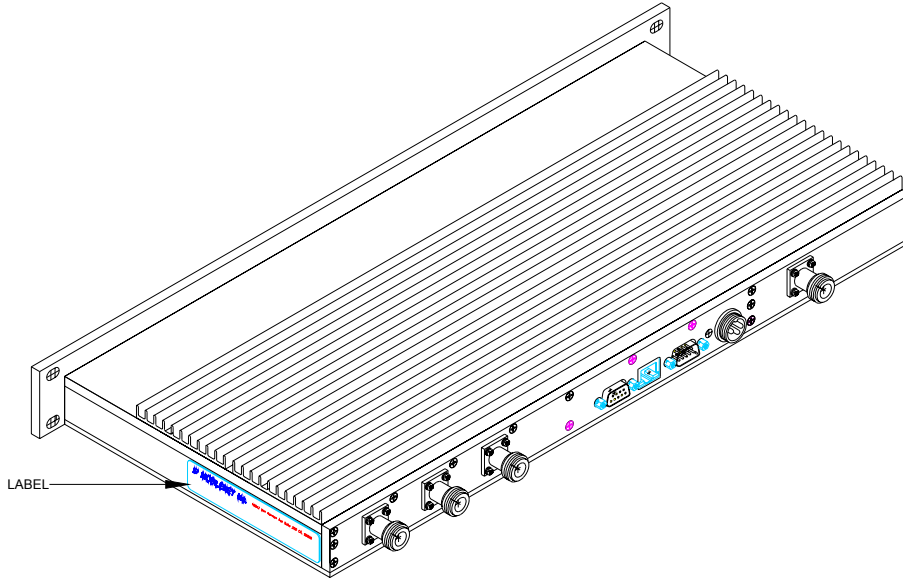

B32450-25 Base Station FCC Label

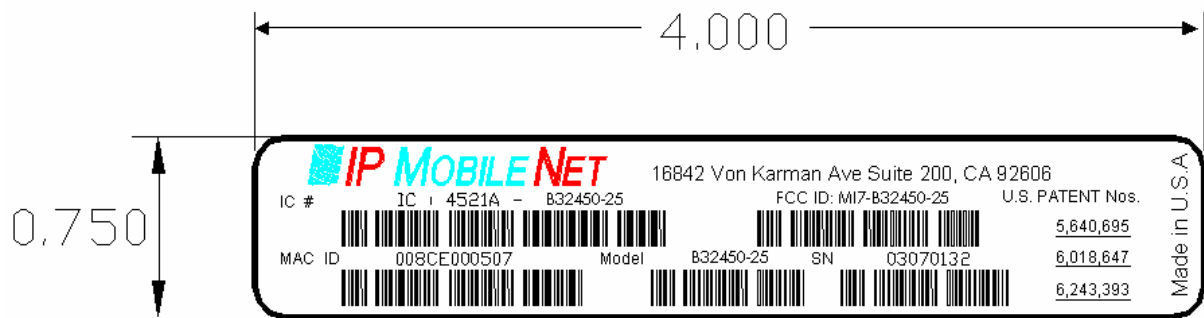

System Controller

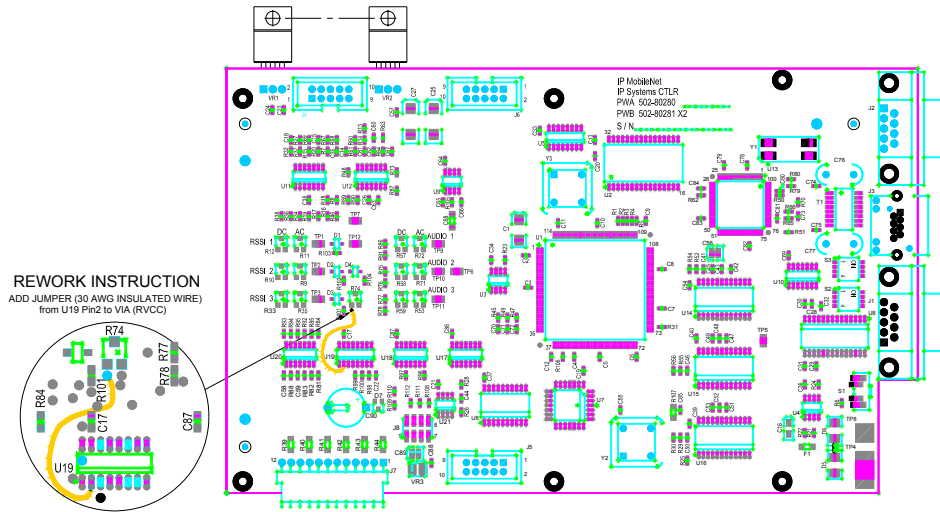

Receiver - Top

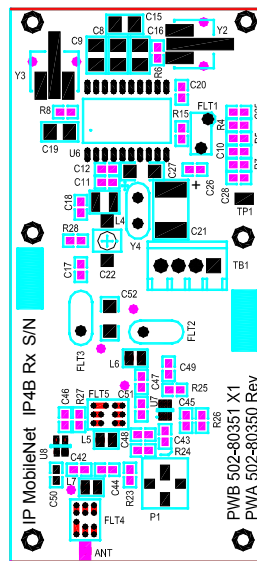

Receiver – Bottom

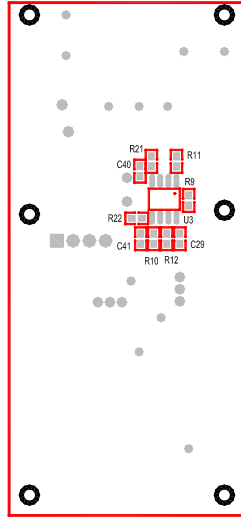

Receiver Injection

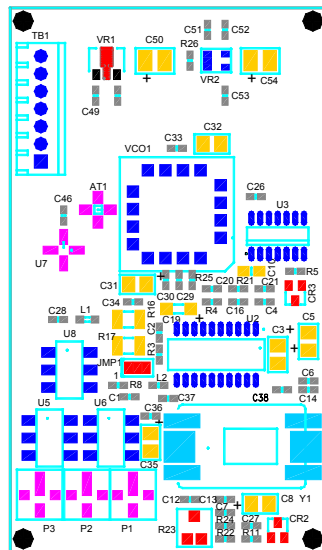

APPENDIX A: CIRCUIT BOARD DIAGRAMS

Exciter – Top

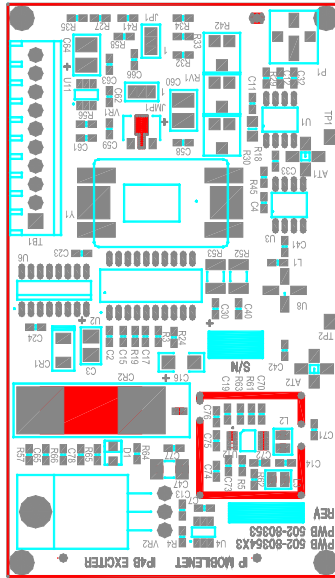

Exciter – Bottom

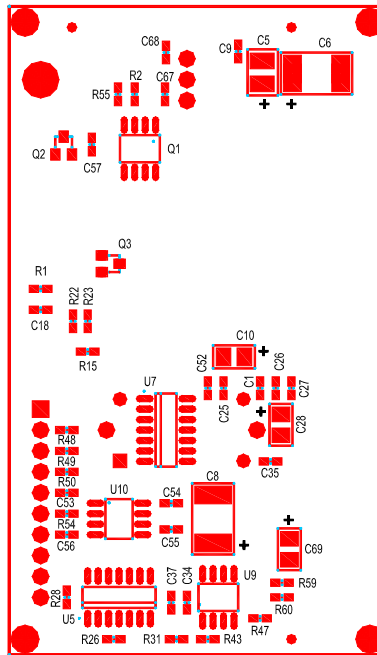

Power Amplifier

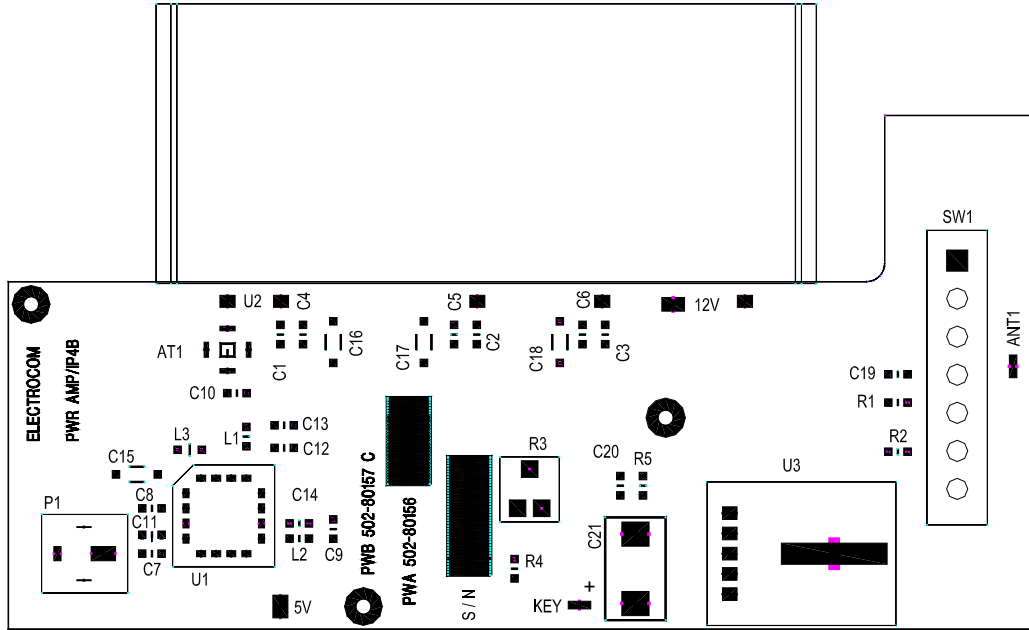

Program and Configure the Base Station

Date _____
 Serial Number _____
 Firmware Revision _____
 End User _____
 Tester _____

Adjustment / Alignment Procedures

Receiver Injection

<u>Parameter</u>	<u>Spec</u>	<u>Measured</u>
Injection Frequency Error at RXINJ1(within +/- 10 Hz of exact injection frequency)	+/- 100 Hz	_____
P1 & C39	5 +/- 1 dBm	_____

Receiver Diversity Reception Controller 1, 2 & 3

<u>Parameter</u>	<u>Spec</u>	<u>Receiver 1 Measured</u>	<u>Receiver 2 Measured</u>	<u>Receiver 3 Measured</u>
U6 Pin 4	+10 to +5 dBm	_____	_____	_____
RSSI Test Point TB1-4	2.8 to 3.0 VDC	_____	_____	_____
Distortion (1 kHz Test Tone @ 5.0 kHz)	3%<	_____	_____	_____
SINAD 12 dB (1 kHz Test Tone @ 5 kHz)	-119dBm >	_____	_____	_____
SINAD 12 dB TP1	0.75 VDC +/- 1 mV	_____	_____	_____
SINAD +50 dB TP1	2.75 +/- 1 mV	_____	_____	_____
Audio AC Amplitude (1 kHz Test Tone @ 5 kHz Deviation)	350 mVRMS +/- 1mV	_____	_____	_____
Audio DC Amplitude (1 kHz Test Tone @ 5 kHz Deviation)	2.5 VDC +/- 1mV	_____	_____	_____
Carrier Detect Light Set	-116 dBm	_____	_____	_____

APPENDIX B: B32450-25 TEST DATA SHEET

Data Quality

<u>Parameter</u>	<u>Spec</u>	<u>Measured</u>
Receiver 1 Data Quality (x=1400, 19 Command <i>IPMessage Utility</i>)	240>	_____
Receiver 2 Data Quality (x=1400, 19 Command <i>IPMessage Utility</i>)	240>	_____
Receiver 3 Data Quality (x=1400, 19 Command <i>IPMessage Utility</i>)	240>	_____

Exciter

<u>Parameter</u>	<u>Spec</u>	<u>Measured</u>
Transmit Frequency Error (Transmitting 1400 character test message)	+/- 500 Hz	_____
Transmit Modulation Deviation (5.3 kHz while transmitting 1400 character test message)	5.1 kHz to 5.3 kHz	_____
Transmit Data Quality (While transmitting 1400 character test message to the base station)	240>	_____

Transmit Power Control

Warning: Do Not exceed 40 Watts RF output power during this test

<u>Parameter</u>	<u>Spec</u>	<u>RF Out</u>	<u>RF Out Max</u>	<u>Level set to</u>
Output Power (Use x=1400,19 command)	40 +/- 1 Watt	_____	_____	_____

Test Check List

<u>Test Task</u>	<u>Completed</u>
Attached copy of Base Station's Firmware Settings	(✓)

Attached copy of Base Station's Firmware Settings

Visual Inspection

Copy Base Station Settings Below: