



Instrument Specialties Company, Inc. — World Compliance Center

EXHIBIT B:

DT450 Product Support Manual

DT450 Product Support Manual

ECS 516-82025 Revision X1

| | | |
|-------|--|----|
| 1. | INTRODUCTION | 1 |
| 1.1 | Document Scope | 1 |
| 1.2 | Reference Documents | 1 |
| 1.3 | Product Features | 2 |
| 1.4 | General Product Description | 2 |
| 1.5 | Functional Block Diagram | 4 |
| 2. | INTERFACE DESCRIPTION | 6 |
| 2.1 | External | 6 |
| 2.1.1 | RF Ports | 6 |
| 2.1.2 | DC Input Power | 6 |
| 2.1.3 | Interface Pinouts | 7 |
| 2.1.4 | Interface Functional Description | 8 |
| 3. | SPECIFICATIONS | 9 |
| 3.1 | DT450 General Specifications | 9 |
| 3.2 | Transmitter Specifications | 10 |
| 3.3 | Receiver Specifications | 11 |
| 3.4 | Mechanical Specifications | 12 |
| 3.5 | Environmental Specifications | 12 |
| 3.6 | Regulatory Agency Specifications | 13 |
| 3.6.1 | FCC | 13 |
| 3.7 | Reliability | 13 |
| 4. | OPERATION AND MAINTENANCE | 14 |
| 4.1 | Modes of Operation | 14 |
| 4.2 | Programming | 14 |
| | | 15 |
| 4.3 | Maintenance | 15 |

| | | |
|-----------|---|-----------|
| 5. | THEORY OF OPERATION | 16 |
| 5.1 | Microcontroller Section | 18 |
| 5.2 | 4-Level FSK Modem Section | 20 |
| 5.3 | Injection Synthesizer | 21 |
| 5.4 | Transmit Baseband Processing | 23 |
| 5.5 | UHF Receiver | 24 |
| | 5.5.1 UHF Front-End Section | 24 |
| | 5.5.2 45 MHz Receiver Section | 26 |
| 5.6 | Diversity Reception Controller | 27 |
| | 5.6.1 RSSI Input Section | 28 |
| | 5.6.2 RSSI Level Shifter | 28 |
| | 5.6.3 Receiver Selector | 29 |
| | 5.6.4 Recovered Modulation Input | 29 |
| | 5.6.5 Recovered Modulation Switch | 30 |
| | 5.6.6 Carrier Detector | 30 |
| 5.7 | Receive Baseband Processing | 31 |
| 5.9 | T/R (Transmit/Receive) Switch | 32 |
| 6. | RECOMMENDED TOOLS AND TEST EQUIPMENT | 33 |
| 6.1 | Recommended Tools | 33 |
| 6.2 | Recommended Test Equipment | 33 |
| 7 | INSTALLATION | 34 |
| 7.1 | Unpacking and Inspection | 34 |
| 7.2 | Installation Instructions | 35 |
| | 7.2.1 Equipment Requirements | 35 |
| | 7.2.2 Installation Procedures | 36 |
| 7.3 | Antenna Considerations | 39 |
| | 7.3.1 Antenna Radiation Pattern | 39 |
| | 7.3.2 Antenna Near-Field Exclusion Zone | 39 |
| | 7.3.3 Antenna Correlation Coefficient | 40 |

| | | |
|------------|---|-----------|
| 7.3.4 | Microstrip Patch Antennas | 40 |
| 8. | MAINTENANCE AND ALIGNMENT PROCEDURES | 41 |
| 8.1.1 | Test Equipment Setup | 41 |
| | | 41 |
| 8.2 | RECOMMENDED TOOLS AND TEST EQUIPMENT | 42 |
| 8.2.1 | Recommended Tools | 42 |
| 8.2.2 | Recommended Test Equipment | 42 |
| 8.3 | Transmitter Alignment Procedure | 43 |
| 8.3.1 | Injection Frequency Adjustment | 43 |
| 8.3.2 | Transmit Modulation Adjustment | 44 |
| 8.4 | Receiver Alignment | 45 |
| 8.4.1 | Receiver #1 Distortion and SINAD Alignment | 45 |
| 8.4.2 | Receiver #2 Distortion and SINAD Alignment | 47 |
| 8.5 | Diversity Reception Controller Alignment | 49 |
| 8.5.1 | RSSI Alignment for Receiver #1 | 49 |
| 8.5.2 | RSSI Alignment for Receiver #2 | 50 |
| 8.5.3 | Receiver Audio Equalization | 51 |
| 9.1 | Transmitter Troubleshooting Flowchart | 53 |
| 9.2 | Receiver Troubleshooting Flowchart | 54 |
| 9.3 | Diversity Reception Controller Functional Troubleshooting Flowchart | 55 |
| 9.4 | Diversity Reception Controller Audio Level Troubleshooting Flowchart | 56 |
| 10 | GLOSSARY | 57 |

1. INTRODUCTION

1.1 Document Scope

This document describes the ElectroCom Model DT450 mobile radio comprehensively.

Section 1: non-technical overview of the product and its features.

Section 2: more detailed; describes various interfaces (i.e. connectors, power sources, interconnections, etc.).

Section 3: covers various specifications the product is designed to meet.

Section 4: contains operating and maintenance instructions.

Section 5: theory of operation, this section contains detailed functional descriptions of circuit operation.

The remaining sections need no explanation.

Throughout this document, SMALL CAPITAL LETTERS are used to indicate signal names used on schematics and *italics* are used when describing circuitry, methods, or devices which affect regulatory compliance.

1.2 Reference Documents

Schematic Diagram, DT450 502-82006 Rev B (attached)

MX●COM MX919A 4-Level FSK Modem Data Pump Product Specification

ATMEL AT89S8252 8-Bit Microcontroller Product Specification

BRXI Protocol Specification ECS PN 517-00001

1.3 Product Features

DT450 Features:

- Patented, dual receiver, diversity reception system
U.S. Patent No. 5,640,695
- High stability - 1.0 ppm
- Internal 4-level FSK modem, 4800, 9600, 19200 bps with DES
- Fast transmit attack time - less than 10 msec
- 2 advanced-architecture, extremely sensitive, high-overload, FM receivers
- 40 Watt Tx output power
- Digital PLL frequency synthesizer
- Broadband operation by design
- Compact size, rugged construction

1.4 General Product Description

The DT450 is a no-compromise, high-performance, synthesized, UHF (400 to 512 MHz) mobile radio with dual-receiver, post-detection diversity reception. The diversity reception system significantly reduces the damaging effects of multipath fading.

Frequency stability over temperature is ensured by a TCVCXO (Temperature Compensated Voltage Controlled Crystal Oscillator) with 1.0 ppm (part per million) frequency stability over the temperature range of -30 to +60 C.

The DT450 includes a 4-level FSK (Frequency Shift Key) modem which supports data rates of 4800, 9600, and 19200 bps. The radio is intended to operate at data rates of up to 19200 bps in a 25 kHz channel, up to 9600 bps in a 12.5 kHz channel, and 4800 bps in a 6.25 kHz channel.

The transmitter design enables stable, on-frequency, RF carrier attack times of less than 10 milliseconds and an output power level of 40 Watts.

The DT450 receivers feature an advanced architecture, cascaded LNA (Low-Noise

Amplifier) design which results in extreme sensitivity and high overload capability.

The radio is capable of operating with any authorized transmit-to-receive frequency separation and is capable of operating on all authorized channels within the 400 to 512 MHz band.

The mechanical package of the DT450 is extremely robust, constructed primarily of machined 1/4" aluminum plate. The excellent thermal conductivity characteristics of heavy gauge aluminum enable the chassis to act as a heat spreader, distributing heat uniformly throughout the entire structure. A mil-spec chemical finish protects the chassis from oxidation.

All inputs and outputs are via EMI/RFI filtered connectors resulting in extremely low undesired emissions (both radiated and conducted) and reduced susceptibility to external sources of EMI/RFI.

The DT450 electrical design reflects a total commitment to Surface Mount Technology (SMT) resulting in reduced size, lower cost, and increased performance.

1.5 Functional Block Diagram

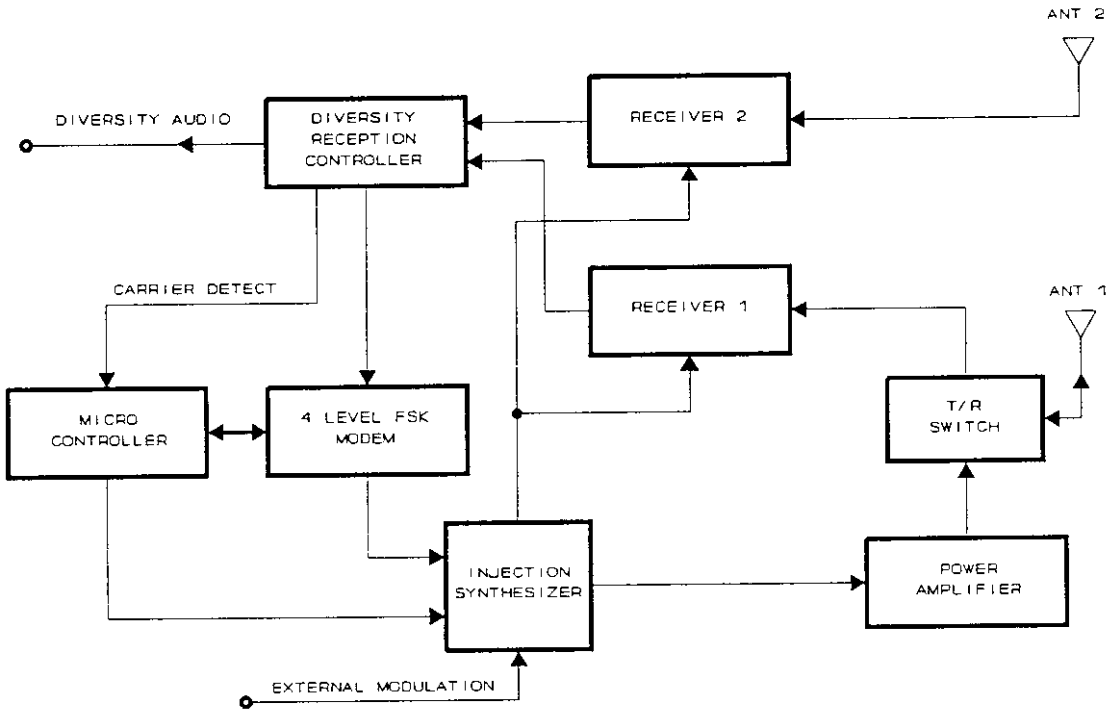

Figure 1. DT450 Functional Block Diagram

The DT450 is divided into eight functional blocks as depicted in *Figure 1*.

Microcontroller: Programs the injection frequency synthesizer, controls the internal 4-level FSK (Frequency Shift Key) radio modem, the RS232 interface, transmit timer, and peripheral devices.

4-Level FSK Modem: Interfaces with the microcontroller and the radio modulation/demodulation circuits to deliver reliable two-way transfer of high-speed data over a wireless link. The modem supports data rates of 4800, 9600, and 19200 bps, under software control.

Injection Synthesizer: Generates the receiver injection signals in the receive mode. Generates the exciter injection signal and accomplishes frequency modulation in the transmit mode.

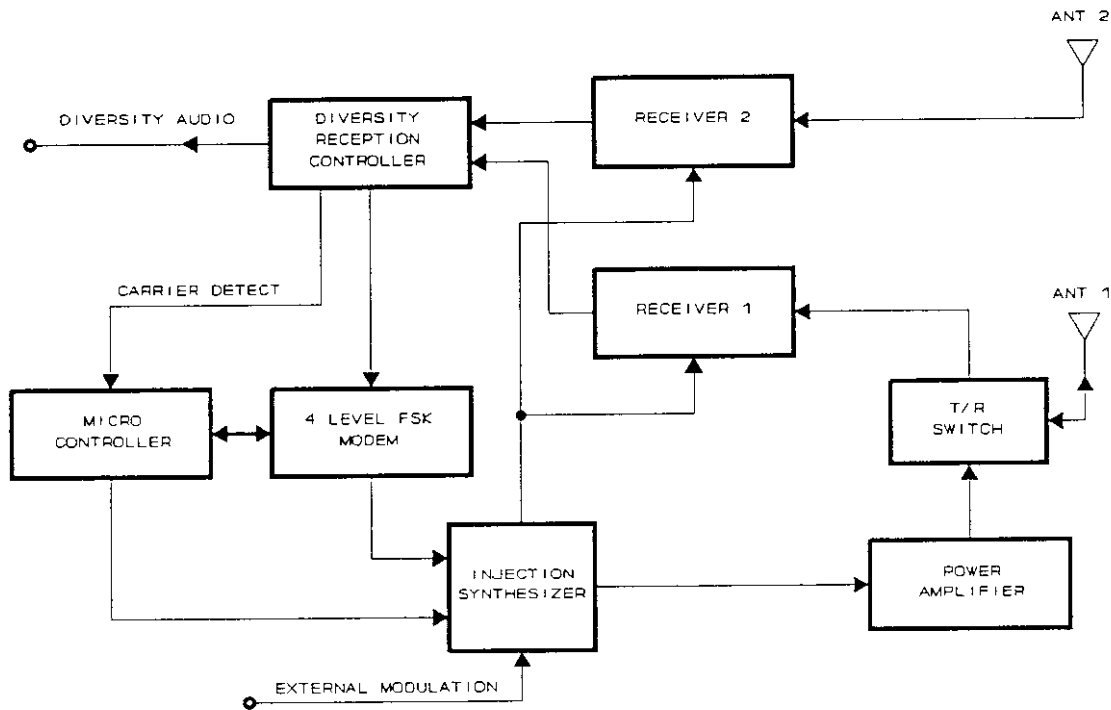

Figure 2. DT450 Functional Block Diagram (Repeated for reader convenience)

- Receiver:** Provides reception and demodulation of Frequency Modulated (FM) UHF (400 to 512 MHz) RF signals. The receivers also provide RF carrier amplitude information used by the diversity reception system.
- DRC (Diversity Reception Controller):** A patented feature which provides diversity reception capability by continuously selecting the receiver with the higher SNR (Signal to Noise Ratio).
- Power Amplifier:** Amplifies the low-level transmit carrier signal from the RF injection section to the final output power level (40 Watts).
- T/R Switch:** Allows one antenna to be used for both transmit and receive operations.

2. INTERFACE DESCRIPTION

2.1 External

2.1.1 RF Ports

The DT450 has two external RF ports. Both are type "N" coaxial connectors mounted directly to the chassis of the radio. J2 is a bi-directional port which serves as the transmit port during transmit operation, and as the receive port for receiver 1 in the receive mode. J3 is a receive only port for receiver 2 and is dedicated to diversity reception.

2.1.2 DC Input Power

DC input power (for the power amplifier) and ground (for the entire radio) is supplied via J4, a 2-conductor quick-disconnect connector. *The positive conductor (red) feeds DC input power to the power amplifier through EMI/RFI (ElectroMagnetic Interference / Radio Frequency Interference) filtered connector FLT1.* The ground conductor (black) is soldered directly to the body of FLT1.

2.1.3 Interface Pinouts

External interface to the radio is provided by connector J1, a EMI/RFI filtered 25 pin "D" type connector. All signals are CMOS levels unless otherwise specified. An asterix at the end of a signal name indicates the signal is active low. The pinouts for J1 connector are defined below.

| PIN # | SIGNAL |
|-------|----------------|
| 1 | GND |
| 2 | SW12VIN |
| 3 | TXKEY* |
| 4 | RXDATA |
| 5 | CTRLHEADENABLE |
| 6 | EXTMOD |
| 7 | CD* |
| 8 | RSSI |
| 9 | RCS0* |
| 10 | RCS1* |
| 11 | RCS2* |
| 12 | RCS3* |
| 13 | GND |
| 14 | GND |
| 15 | RCS4* |
| 16 | TXD |
| 17 | RXD |
| 18 | RESETIN* |
| 19 | SPIDATAOUT |
| 20 | SPICLOCK |
| 21 | SPIDATAIN |
| 22 | CTS |
| 23 | RTS |
| 24 | RX1/RX2* |
| 25 | GND |

2.1.4 Interface Functional Description

| Signal Name | Input Output Power | Description |
|-------------|--------------------|--|
| GND | P | Signal ground |
| SW12VIN | P | Switched 12.0 volt DC power source |
| TXKEY* | I | A logic low on this pin will cause the DT450 to key, used by a control head or an external modem device to key the radio |
| RXDATA | O | Recovered modulation, diversity reception discriminator audio, low-pass filtered by a 4th-order 4800 Hz Bessel filter, approximately 600 mV peak-to-peak for a 1.0 kHz test tone at +/- 4.0 kHz deviation |
| CHENABLE | O | Control head enable, used to program the DT control head. |
| EXTMOD | I | External transmit modulation from the DT control head or an external modem device |
| CD* | O | Carrier Detect signal, a logic level low on this pin indicates channel activity |
| RCS0 - RCS4 | I | Parallel data interface Radio Channel Select lines, 5 bit - 32 channel. Used by an external device to select radio channels |
| TXD | I | RS232 transmit data, this pin is used by an external device to transmit application data to the internal modem, this pin is not used when the DT450 is using an external modem |
| RXD | O | RS232 receive data, this pin is used by the internal modem to transmit application data to the external device, this pin is not used when the DT450 is using an external modem |
| RESETIN* | I | This pin is used to program the DT450 microcontroller |
| SPIDATAOUT | O | Serial communication data out line, used to program the DT450 control head |
| SPICLOCK | IO | Serial communication clock line, bi-directional |
| SPIDATAIN | I | Serial communication data in line, |
| CTS | O | RS232 Clear To Send signal, used for hardware flow control |
| RTS | I | RS232 Request To Send signal, used for hardware flow control |
| RX1/RX2* | I | A logic high on this pin will manually select receiver #1 to supply recovered modulation; a logic low will select receiver #2 to supply recovered modulation, used for receiver maintenance and alignment purposes |

3. SPECIFICATIONS

3.1 DT450 General Specifications

| PARAMETER | SPECIFICATION |
|--|--|
| Frequency range | 400 to 512 MHz (in 20 MHz bands) |
| Channel spacing | 12.5 / 25.0 kHz |
| Mode of operation | Half-duplex, diversity reception |
| Operating temperature range | -30 to +60 C (-22 to +140 F) |
| Power supply voltage | 13.8 VDC +/- 20% |
| Power supply current consumption | 0.75 A receive 9.0 A transmit |
| Diversity reception system | Dual-receiver, diversity reception system |
| Antenna connections | Two type "N" connectors (Tx/Rx1, Rx2) |
| <i>Interface connection</i> | <i>EMI shielded 25 pin "D" type connector</i> |
| Frequency selection: External frequency control | Parallel data interface, five bit 32 channel or serial communication interface |

3.2 Transmitter Specifications

| PARAMETER | SPECIFICATION |
|--|---|
| Frequency range | 400 to 512 MHz |
| Channel spacing | 12.5/25.0 kHz |
| Frequency source | Dielectric resonator based VCO |
| Frequency stability | +/- 1.0 ppm (.00001%) -30C to +60C (-22F to +140F) |
| <i>Spurious and harmonic emissions</i> | <i>-13 dBm (maximum level)</i> |
| Transmit power | 40 watts minimum (20 MHz bandwidth) |
| VSWR at transmit antenna port | 2.0 or less (400 to 512 MHz) |
| Load mismatch tolerance | 8.8 : 1 (no degradation) |
| Transmit attack time | Less than 10 ms |
| Transmit duty cycle | Intermittent |
| Modulation | 4-level FSK using internal modem, or any CPM compliant narrow-band FM modulation using an external modem device |
| Transmit modulation group delay | Constant (+/- 2.0 usec) from 3 Hz to 4.8 kHz, fourth-order Bessel response |
| Modulation input | 1.0 volt peak-to-peak for + / - 4.0 kHz deviation (1.0 kHz test tone). |

3.3 Receiver Specifications

| PARAMETER | SPECIFICATION |
|----------------------------|--|
| Frequency Range | 400 to 512 MHz (in 20 MHz bands) |
| Channel Spacing | 12.5 / 25.0 kHz |
| Injection Frequency | 45 MHz below the base station frequency (low-side injection) |
| Sensitivity | 12.0 dB SINAD at -121 dBm maximum level 12.0 dB SINAD at -122 dBm typical 12.0 dB SINAD at -123 dBm typical with diversity |
| Selectivity | 70 dB (minimum at +/- 25 kHz) |
| Spurious response | 85 dB minimum |
| Intermodulation distortion | 75 dB minimum |
| IF bandwidth | +/- 7.5 kHz standard, +/- 4.5 kHz & +/- 10 kHz optional |
| Modulation acceptance | +/- 7.5 kHz minimum with standard bandwidth |
| Recovered modulation | Approximately 600 mV peak-to-peak for 1.0 kHz test tone at +/- 4.0 kHz deviation |
| Distortion | Less than 3% at 1.0 kHz, less than 1.5% at 1.0 kHz typical |

3.4 Mechanical Specifications

| PARAMETER | SPECIFICATION |
|-------------------------------------|---------------|
| Width (excluding mounting bracket) | 4.40" |
| Depth (excluding mounting bracket) | 8.60" |
| Height (excluding mounting bracket) | 2.75" |
| Width (including mounting bracket) | 8.60" |
| Depth (including mounting bracket) | 8.60" |
| Height (including mounting bracket) | 3.50" |
| Weight | 4.0 lbs |

3.5 Environmental Specifications

| PARAMETER | SPECIFICATION |
|-----------------------------------|---------------|
| High Humidity - Transmitter | EIA/TIA-152-C |
| High Humidity - Receiver | EIA/TIA-204-D |
| Shock Stability - Transmitter | EIA/TIA-152-C |
| Shock Stability - Receiver | EIA/TIA-204-D |
| Vibration Stability - Transmitter | EIA/TIA-152-C |
| Vibration Stability - Receiver | EIA/TIA-204-D |
| Temperature Range - Transmitter | EIA/TIA-152-C |
| Temperature Range - Receiver | EIA/TIA-204-D |

3.6 Regulatory Agency Specifications

3.6.1 FCC

| SPECIFICATION | RULE SECTION |
|---|-----------------------------------|
| <i>Transmitter conducted spurious emissions</i> | <i>CFR 47 Part 2 Section 991</i> |
| <i>Transmitter radiated spurious emissions</i> | <i>CFR 47 Part 2 Section 993</i> |
| <i>Transmitter frequency stability</i> | <i>CFR 47 Part 2 Section 995</i> |
| <i>Transmitter RF output power</i> | <i>CFR 47 Part 2 Section 985</i> |
| <i>Transmitter occupied bandwidth</i> | <i>CFR 47 Part 2 Section 989</i> |
| <i>Receiver Spurious emissions</i> | <i>CFR 47 Part 15 Section 63</i> |
| <i>Computer emissions (Class B)</i> | <i>CFR 47 Part 15 Section 810</i> |

3.7 Reliability

The DT450 is constructed of top quality components with the highest possible level of integration resulting in an inherently reliable product.

The DT450 shall operate reliably.

4. OPERATION AND MAINTENANCE

4.1 Modes of Operation

The DT450 is a simplex / half-duplex two-way mobile radio with dual receiver diversity reception. The radio can operate with carrier frequencies between 400 and 512 MHz in bands of 20 MHz. The DT450 has two RF ports, one transmit/receive port, and one receive only port (dedicated to diversity reception).

The radio is capable of operating with any authorized transmit-to-receive frequency separation and is capable of operating on all authorized channels within the 400 to 512 MHz band.

The DT450 is capable of voice operation with an external control head. In this configuration, the radio is also capable of talk-around operation (transmitting on the repeater down-link frequency for short range communications). The radio may also be used with an external radio modem provided the modulation scheme is a form of CPM (Continuous Phase Modulation).

The DT450 includes a 4-level FSK modem which supports data rates of 4800, 9600, and 19200 bps. The ability to operate at any particular data rate is subject to regulatory compliance and is primarily a function of channel bandwidth. The radio is intended to operate at data rates of up to 19200 bps in a 25 kHz channel, up to 9600 bps in a 12.5 kHz channel, and 4800 bps in a 6.25 kHz channel.

The DT450 receivers come standard with a 15 kHz IF bandwidth (standard for 25 kHz channel spacing). Other IF bandwidths (20 kHz, 12.5 kHz, etc.) are available optionally.

4.2 Programming

Radio channel transmit/receive frequencies, internal / external modem operation, voice operation parameters, and transmit timer functions are programmed into the radio prior to operation. Programming can be accomplished at the factory, or in the field using a DT series radio programming kit ECS PN 502-82029. The kit consists of software (which will run on any IBM PC or compatible), a radio programming cable (which connects from the PC's printer port to the radio), and a radio programming instruction manual. The radio may be re-programmed up to 1,000 times.

4.3 Maintenance

WARNING

FCC regulations require that the frequency and deviation of a transmitter must be checked before it is placed into service and re-checked at one year intervals thereafter.

FCC regulations also state that the RF output power of a radio transmitter shall be no more than that required for satisfactory operation considering the area to be covered and local conditions.

FCC ID number for the DT450 Transmitter: MI7-ECSDT450TX

In addition to the required annual frequency and deviation checks, it is recommended the following items be checked (and adjusted, if necessary) at yearly intervals:

- Transmit output power
- Receiver sensitivity
- Receiver distortion
- DRC (Diversity Reception Controller) operation

5. THEORY OF OPERATION

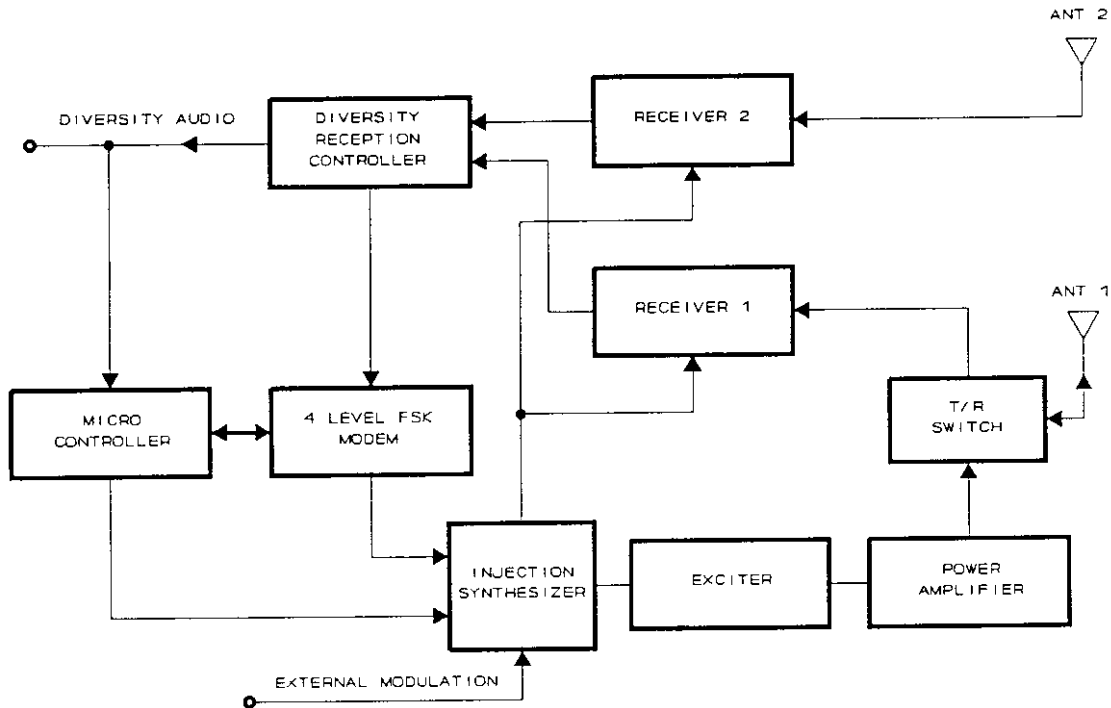

Figure 3. DT450 Functional Block Diagram (Repeated for reader convenience)

The DT450 is divided into eight functional blocks as depicted in *Figure 3*.

- Microcontroller:** Programs the injection frequency synthesizer, controls the internal 4-level FSK radio modem, the RS232 interface, Parallel RCS (Radio Channel Select) interface, the transmit timer, and peripheral devices (control head display, CTCSS (Continuous Tone Coded Squelch System) encoder/decoder, etc.)
- 4-Level FSK Modem:** Interfaces with the microcontroller and the radio modulation/demodulation circuits to deliver reliable two-way transfer of high-speed data over a wireless link.
- Injection Synthesizer:** Generates the receiver injection signals in the receive mode and generates the exciter injection signal and accomplishes modulation in the transmit mode

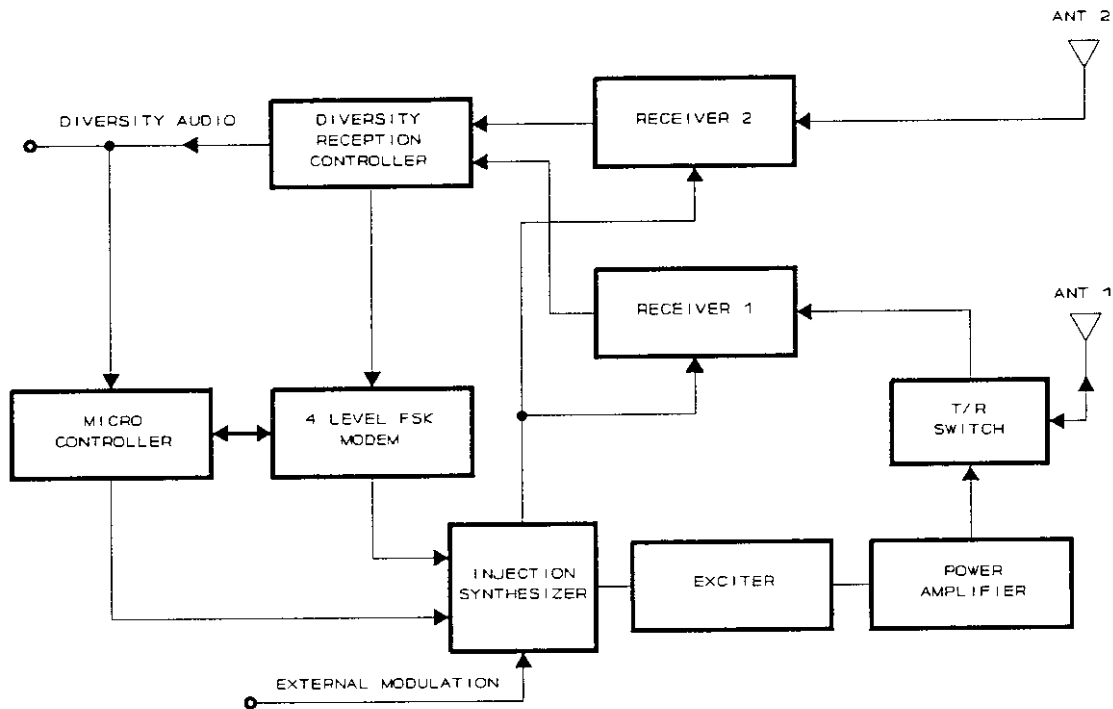

Figure 1. DT450 Functional Block Diagram (Repeated for reader convenience)

- Receiver:** Provides reception and demodulation of FM (Frequency Modulated) UHF RF signals. The receivers also provide RF carrier amplitude information used by the DRC.
- DRC (Diversity Reception Controller):** Provides diversity reception operation by continuously selecting the receiver with the highest SNR (Signal to Noise Ratio) at any particular point in time.
- Power Amplifier:** Amplifies the low-level transmit carrier signal from the injection synthesizer to the final output power level (40 Watts).
- T/R Switch:** Allows one antenna port to be used for both transmit and receive operations.

5.1 Microcontroller Section

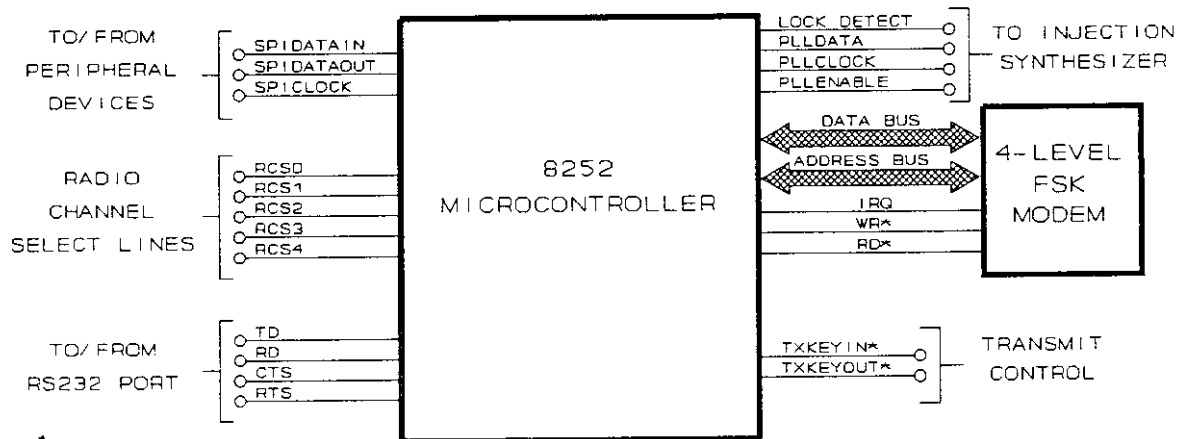

Figure 3. Microcontroller Functional Block Diagram

The DT450 microcontroller controls all programmable devices in the radio and handles all internal and external communications. The microcontroller is in essence, the brain of the radio. The microcontroller is designed around the ATMEL AT89S8252 8-Bit Microcontroller with 8k bytes of downloadable Flash memory (programmable and erasable read only memory), 2k bytes of EEPROM (Electrically Erasable Programmable Read Only Memory), and 256 x 8 bit internal RAM (Random Access Memory). The microcontroller also contains a SPI serial interface for programming peripheral devices, and a programmable UART (Universal Asynchronous Receiver/Transmitter) which handles the serial port. Reference ATMEL AT89S8252 product specification for more detailed information on this part.

The microcontroller is responsible for keeping the radio on channel by programming the digital PLL frequency synthesizer. This task is accomplished via a serial communications interface which consists of three signals PLLDATA, PLLCLOCK, and PLENABLE. The PLLDATA signal provides the PLL data for the synthesizer, the PLLCLOCK signal clocks the data into the synthesizer, and the PLENABLE signal enables synthesizer programming. After initially programming the synthesizer, the microcontroller monitors the synthesizer's lock detect signal. Upon detecting a un-locked condition, the microcontroller will re-program the synthesizer to lock the radio on channel.

The microcontroller controls the DT450's internal 4-Level FSK modem. In the transmit mode of operation, the microcontroller accepts application data from an external device via a RS232 interface using the BRXI protocol. The BRXI protocol provides for error checking and identifies the individual messages (also known as frames) in the serial data stream. The microcontroller then encrypts the message using DES and forwards this data to the modem

for transmission. In the receive mode of operation, the modem passes received application data to the microcontroller. The microcontroller checks the ID field of the standard message portion of the received message to determine whether to pass this message to the external device. If so, it decrypts the message, attaches the BRXI header and forwards the data to the external device via the RS232 interface.

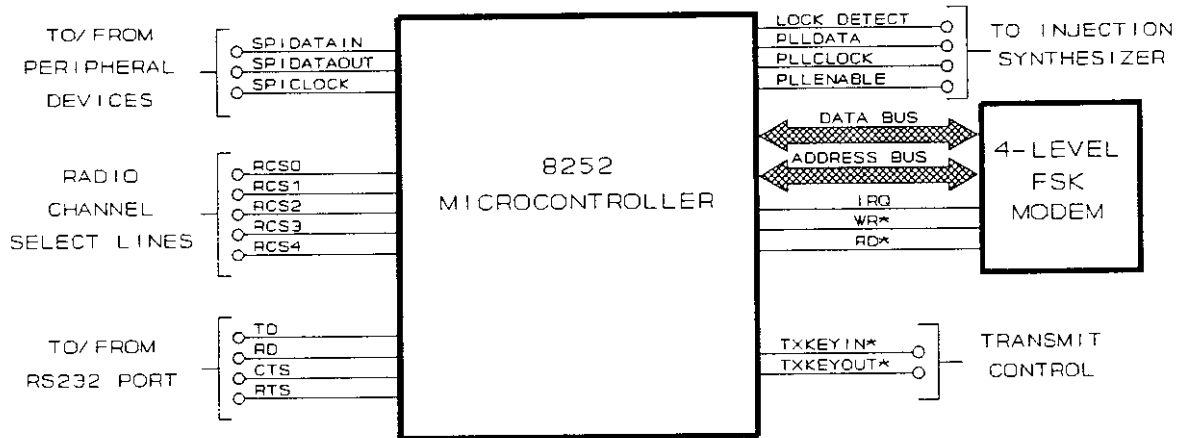

Figure 6. Microcontroller Functional Block Diagram (Repeated for reader convenience)

The microcontroller controls peripheral devices (control head display, CTCSS encoder/decoder, etc.) via a serial communications interface which consists of SPIDATAIN, SPIDATAOUT, SPICLOCK, and various chip enable signals. SPIDATAIN provides data to the microcontroller, SPIDATAOUT provides data from the microcontroller to various devices, SPICLOCK provides synchronization of the data and the various chip enable lines determine which device is communicating with the microcontroller. The microcontroller also supports a 5-bit parallel data interface for external channel selection (32 channels can be accommodated by this method). The microcontroller continuously monitors the five RCS (Radio Channel Select) lines (RCS0* through RCS4*); and, upon detecting a change in state, will automatically load new frequency information into the frequency synthesizer. The microcontroller also reloads the frequency synthesizer when switching between transmit and receive modes.

The microcontroller provides a programmable transmit time-out-timer function to eliminate the possibility of inadvertent continuous transmit operation.

5.2 4-Level FSK Modem Section

The DT450 contains an internal 4-Level FSK modem for reliable transfer of data over-the-air. The modem interfaces with the microcontroller and the DT450's modulation / demodulation circuits to deliver reliable two-way transfer of high-speed application data over a wireless link.

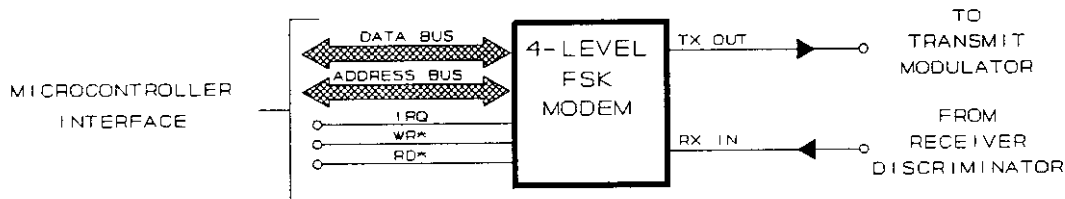

Figure 6. 4-Level FSK Modem Functional Block Diagram

The modem assembles application data received from the microcontroller, adds forward error correction (FEC) and error detection (CRC) information and interleaves the result for burst-error protection. After automatically adding symbol and frame sync codewords, the data packet is converted into filtered 4-Level analog signals for modulating the DT450's transmitter.

In the receive mode, the modem performs the reverse function using the analog signals from the receiver's discriminator. After error correction and removal of packet overhead, the recovered application data is supplied to the microcontroller. CRC detected residual errors will be flagged.

The modem uses data block sizes and FEC/CRC suitable for high-speed transfer of data over narrow-band radio links. The modem can be operated at 4.8 kbps, 9.6 kbps, and 19.2 kbps under software control.

The modem is a highly integrated device incorporating many advanced features which are beyond the scope of this document. Reference MX•COM MX919A 4-Level FSK Modem Data Pump product specification for more detailed information regarding this device.

5.3 Injection Synthesizer

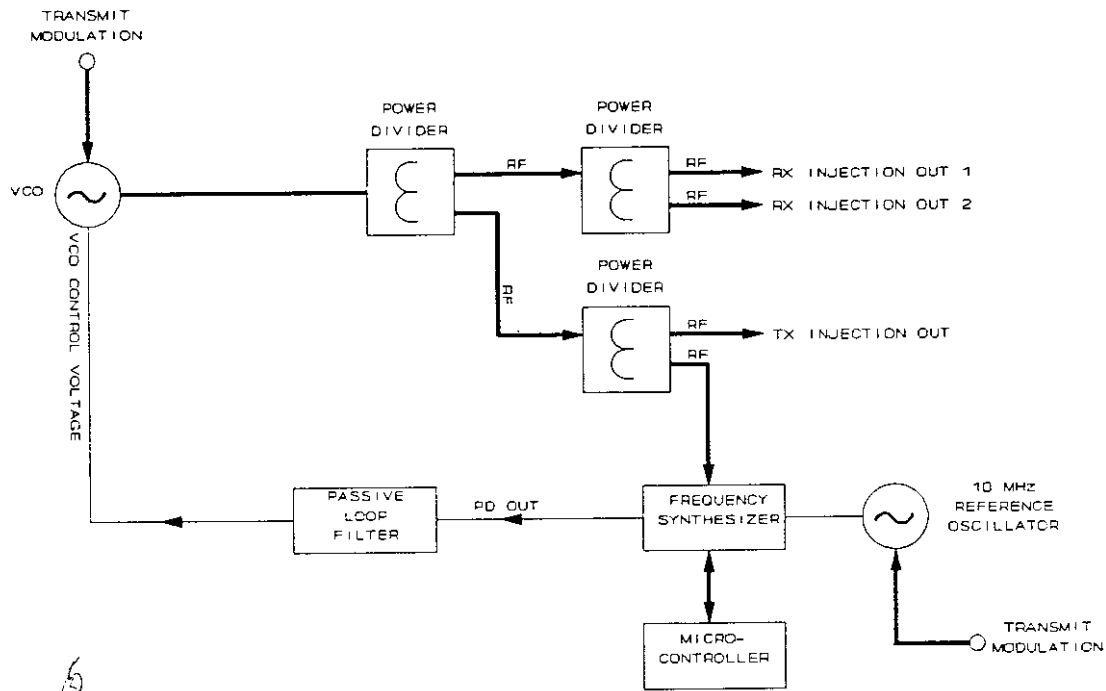

Figure 7. Injection Synthesizer Functional Diagram

The injection synthesizer creates the receiver injection signals in the receive mode of operation, and the transmit injection signal during transmit operation. Figure 7 is a functional diagram of the DT450's injection synthesizer section.

The receiver injection frequency is 45 MHz below the base station transmit frequency

The 450 MHz (nominal) signal from the VCO is applied to a divider. The divider splits this signal into two equal amplitude signals. Each of these signals are further divided by two additional dividers to produce a total of four equal amplitude injection signals. Two of these signals (RX INJECTION OUT 1 and RX INJECTION OUT 2) are used by the DT450's dual receivers in the receive mode. The receivers mix the injection signals (45 MHz below the operating frequency) with the 450 MHz (nominal) received signal to produce a 45 MHz IF (Intermediate Frequency) signal.

The third RF signal (TX INJECTION OUT) is used by the DT450's transmitter during transmit operation. Transmit modulation is applied to VCO as well as the 10 MHz reference oscillator to produce FM modulation (reference the transmit processing section for more detailed information). The TX INJECTION OUT signal is sent to the power amplifier section

for final amplification prior to transmission.

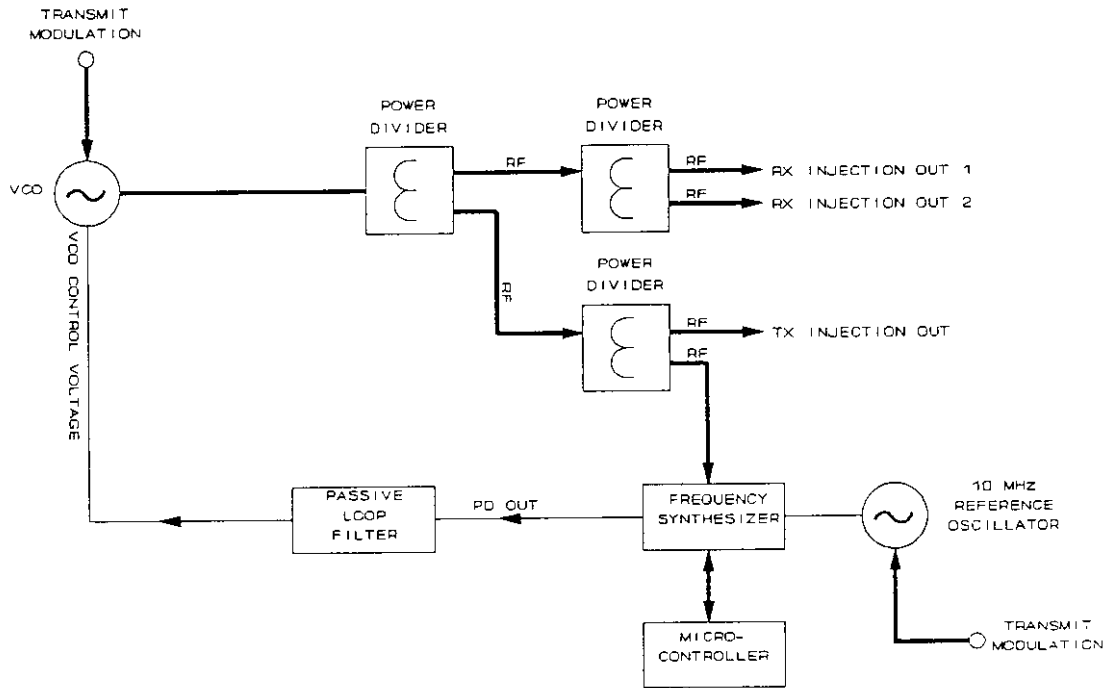

Figure 8. Injection Synthesizer Functional Diagram (Repeated for reader convenience)

The fourth injection signal is used at all times by the digital frequency synthesizer to keep the radio on channel.

The frequency synthesizer divides the injection signal to produce a quotient signal of 12.5 kHz. The synthesizer also divides the signal from the 10.0 MHz reference oscillator to produce a 12.5 kHz signal. The synthesizer compares the phase of these two signals and outputs a signal (PD OUT) proportional to their phase difference. A passive loop filter converts the PD OUT signal to a DC control voltage which locks the VCO on channel.

In this manner, the VCO is compared to - and forced to emulate - the high-stability reference oscillator. This configuration is commonly referred to as a digital Phase-Locked-Loop (PLL) frequency synthesizer.

5.4 Transmit Baseband Processing

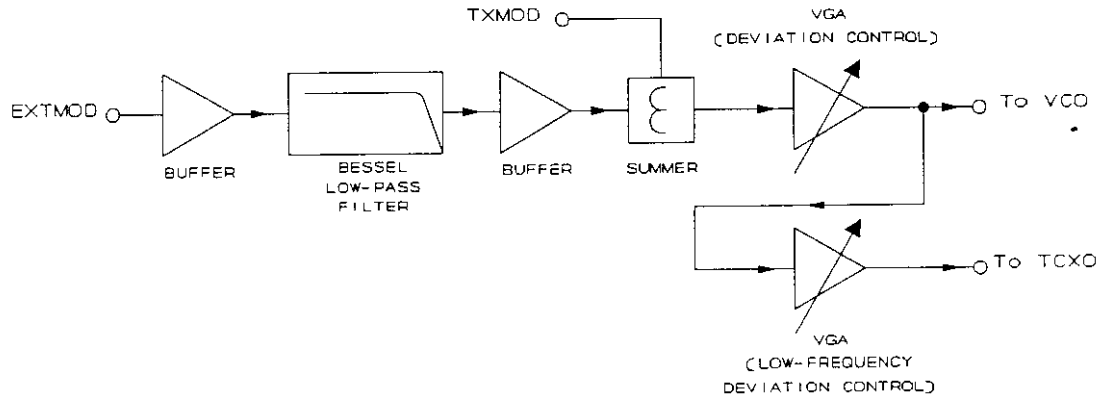

Figure 9. Transmit Baseband Processing Functional Diagram

Figure 9 is a functional diagram of the DT450's transmit baseband processing section.

The DT450 is capable of being modulated by an external device (control head, external modem, etc.) or by the internal 4-level FSK modem. External modulation and internal modem modulation are, at any one point in time, mutually exclusive.

External modulation (EXTMOD) from an external device (control head, external modem, etc.) is buffered to provide load isolation and is then routed to a fourth-order Bessel low-pass filter. The purpose of this filter is to remove any high-frequency components present in the external modulation prior to application to the transmit modulator. Following the filter, the external modulation is buffered to provide load isolation to the filter. The modulation is routed through a summer and is applied to a VGA (Variable Gain Amplifier) which provides transmit modulation deviation control.

The output of the first VGA directly modulates the VCO. This signal is also routed through another VGA which provides low-frequency deviation control by modulating the reference oscillator. This configuration is referred to as two-point modulation (with the VCO and the reference oscillator being the two modulation points). Two point modulation prevents the radio's PLL circuitry from counteracting the modulation process, and provides a clean flat modulation response to the low frequency portion of the baseband spectrum.

4-level FSK modulation from the internal modem bypasses the Bessel filter as the modem contains built-in filtering. This modulation is routed through the summer and is similarly sent to the VCO and reference oscillator in the same manner as the external modulation.

5.5 UHF Receiver

The DT450 employs two independent, high-performance, low-noise, dual conversion FM receivers. The receiver is divided into two main sections, a front-end section and a 45 MHz receiver section.

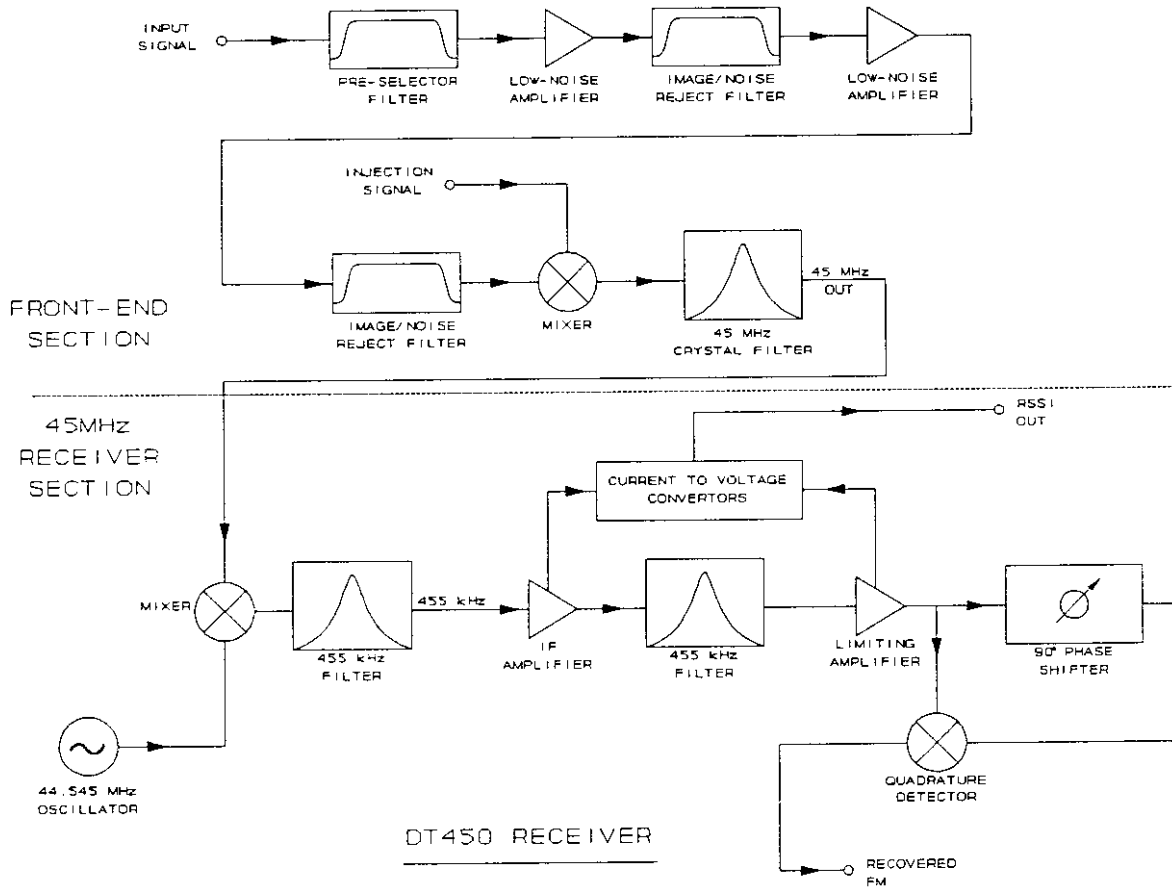

Figure 10. UHF Receiver Functional Diagram

5.5.1 UHF Front-End Section

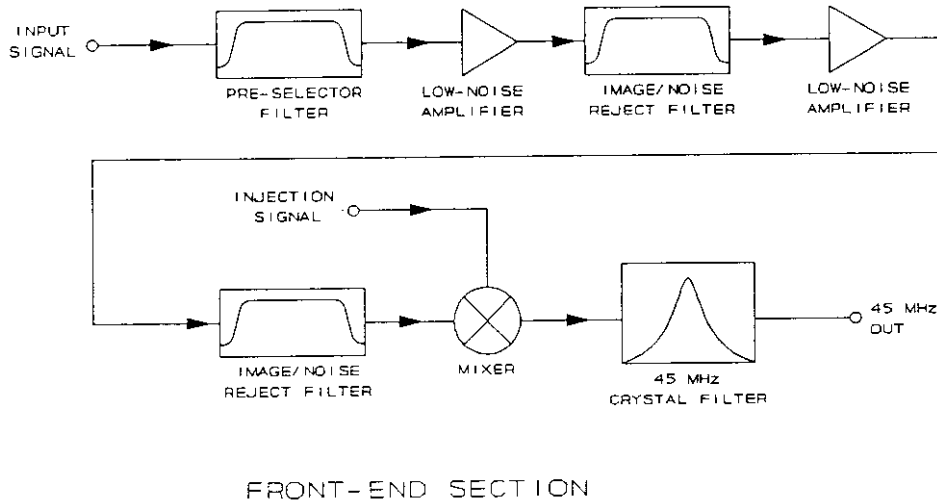

Figure 11. UHF Receiver Front-End Functional Diagram

Figure 11 is a functional block diagram of the receiver front-end section. The front-end section employs an advanced-architecture cascaded-LNA (Low Noise Amplifier) design for extreme sensitivity and high-overload performance.

Receiver input signals are first filtered by a pre-selector band-pass filter and are then routed to a LNA. The amplified signal is routed through another band-pass filter (which functions as a image/noise reject filter) to a second LNA. The output of the second LNA is passed through yet another band-pass filter.

The cascaded LNA configuration ensures a very low receiver noise figure which translates to increased sensitivity. The cascaded band-pass filter configuration acts to sharpen the filter's frequency response skirts, thereby providing greater out-of-band rejection performance.

After the final band-pass filter, the signal is applied to a mixer where it is mixed with the receiver injection signal (45 MHz below the received signal) to produce a first IF (Intermediate Frequency) of 45 MHz. The 45 MHz IF is passed by a 45 MHz crystal filter and is routed to the 45 MHz receiver section for further processing.

5.5.2 45 MHz Receiver Section

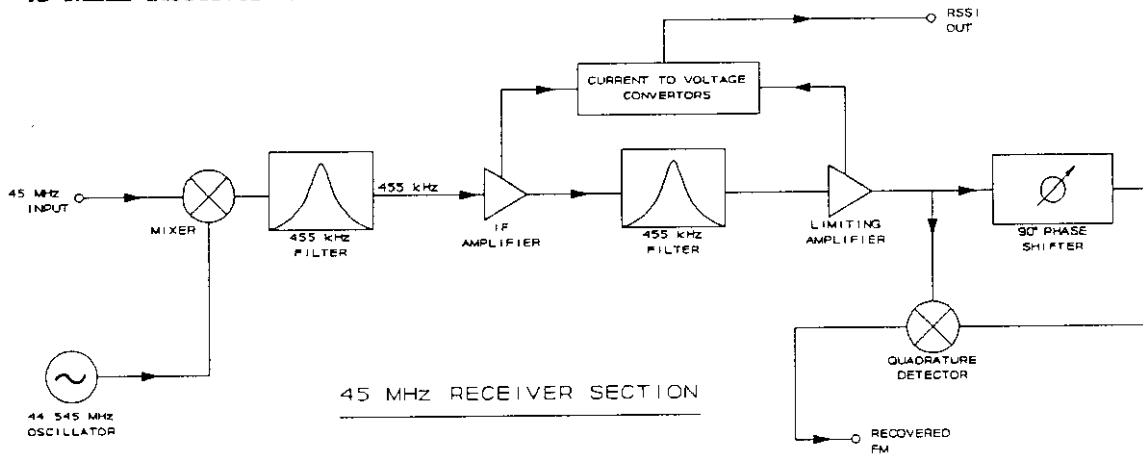

Figure 12. 45 MHz Receiver Functional Diagram

Figure 12 is a functional block diagram of the 45 MHz receiver. The 45 MHz first IF from the front-end is mixed with a 44.545 MHz injection frequency to produce a 455 kHz second IF which is passed by a 455 kHz filter. The second IF is then amplified and limited by an IF amplifier and limiting amplifier respectively. A 455 kHz filter provides interstate filtering between the IF amplifier and the IF limiting amplifier.

This section includes the current-to-voltage convertors which produce the RSSI signal (a DC voltage proportional to the log of the received signal strength). The RSSI responds to signals as low as -132 dBm and rises monotonically over a range of approximately 90 dB. RSSI is used by the diversity reception system to select the best receiver at any particular point in time.

The output of the limiting amplifier is applied to a tuned quadrature detector which outputs recovered Frequency Modulation (FM).

5.6 Diversity Reception Controller

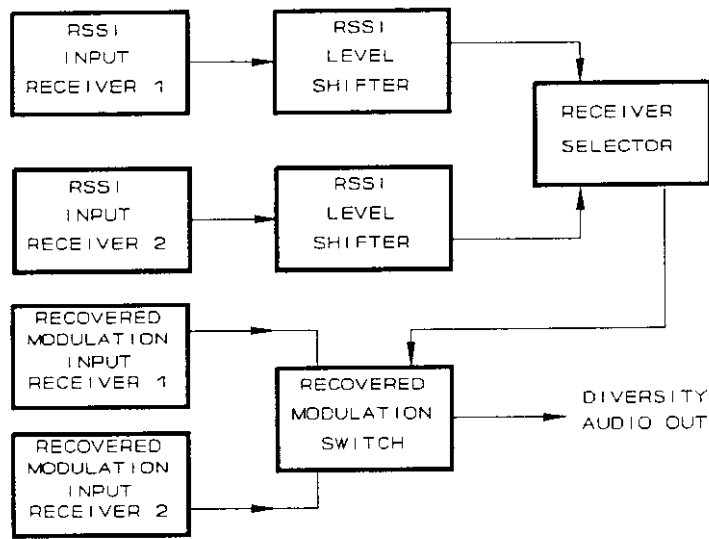

Figure 13. DRC Functional Block Diagram

Figure 13 is a functional block diagram of the DRC (Diversity Reception Controller). The DRC is the central processor of a dual-receiver diversity reception system. The DRC accepts inputs from two receivers, determines which receiver has the better SNR (Signal to Noise Ratio), and selects that receiver to supply recovered modulation.

High-speed RSSI from both receivers are processed by the RSSI input and RSSI level shifter sections and are then forwarded to the receiver selector, and carrier detector sections. The receiver selector selects the appropriate receiver and the carrier detector provides a high-speed indication of channel activity.

Recovered modulation from both receivers is processed by the recovered modulation input and is sent to the recovered modulation switch which performs the actual selection process as directed by the receiver selector.

The DRC is divided into 7 functional sections.

5.6.1 RSSI Input Section

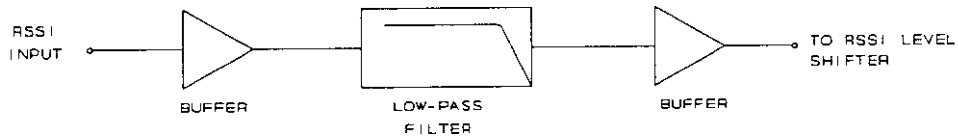

Figure 14. RSSI Input Section Functional Diagram

Figure 14 is a functional diagram of the RSSI input section of the DRC (for ease of explanation, only one section is shown). RSSI from each receiver is buffered to provide RSSI load isolation. Next, the buffered RSSI is low-pass filtered to remove high frequency components (above the frequency of fade induced amplitude fluctuations). This improves the diversity selection process at relatively low RF levels. Finally, the conditioned RSSI is buffered again for isolation and forwarded to the level shifter for further processing.

5.6.2 RSSI Level Shifter

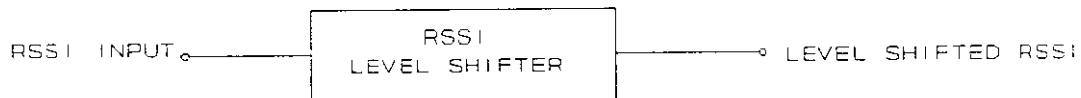

Figure 15. RSSI Level Shifter Block Diagram

Figure 15 is a block diagram of the DRC's RSSI level shifter (for ease of explanation, only one section is shown). The purpose of the level shifter is to compensate for discrepancies in RSSI and sensitivity between receivers. The RSSI level shifter essentially equalizes the performance of the receivers. The level shifter contains an amplifier with adjustable slope and adjustable threshold levels. The output of the level shifter is sent to the receiver selector and carrier detector sections.

5.6.3 Receiver Selector

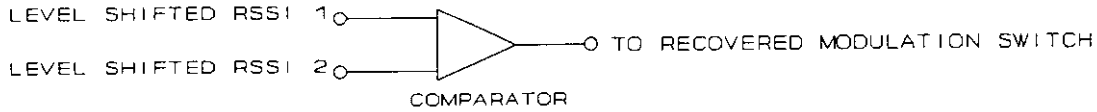

Figure 16. Receiver Selector Functional Diagram

Figure 16 is a functional diagram of the DRC's receiver selector. The receiver selector uses level-shifted RSSI to select the appropriate receiver. In essence, the selector is a comparator which will output one logic level if receiver 1 RSSI is higher than receiver 2 RSSI (and will output the other logic level otherwise). This section develops the control signal used to actuate the recovered modulation switch.

5.6.4 Recovered Modulation Input

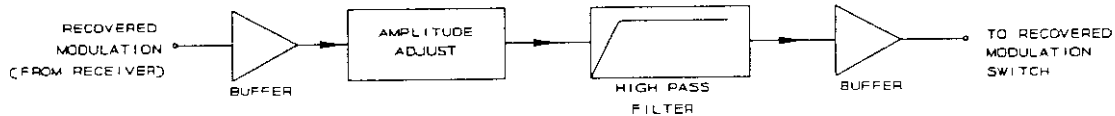

Figure 17. Recovered Modulation Input Functional Diagram

Figure 17 is a functional diagram of the recovered modulation input. Recovered modulation from the receiver is first buffered to provide load isolation. This buffered signal is then sent to a level adjust circuit which equalizes its amplitude. The signal is then high-pass filtered to remove low-frequency components of the recovered signal (below the frequency of the modulation). Finally, the signal is buffered for isolation and forwarded to the recovered modulation switch.

5.6.5 Recovered Modulation Switch

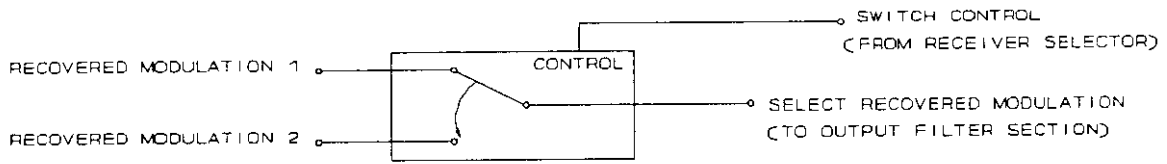

Figure 18. Recovered Modulation Switch Functional Diagram

Figure 18 is a functional diagram of the DRC's recovered modulation switch. This section receives recovered modulation from both receivers as inputs. A control signal from the receiver selector actuates the switch appropriately. The output of the switch is diversity reception recovered modulation.

5.6.6 Carrier Detector

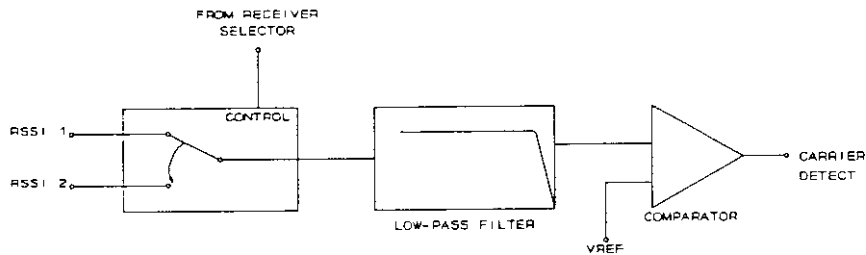

Figure 19. Carrier Detector Functional Diagram

Figure 19 is a functional diagram of the DRC carrier detector. The carrier detector receives RSSI from both receivers. A control voltage (from the receiver selector) continuously selects RSSI from the selected receiver. This select RSSI signal is then low-pass filtered to remove any switch induced transients and to improve performance at relatively low RF levels. This signal is applied to a comparator. If the signal is above a reference value, the comparator will generate a logic low indicating carrier activity. The threshold of carrier detect is factory set to -107 dBm.

5.7 Receive Baseband Processing

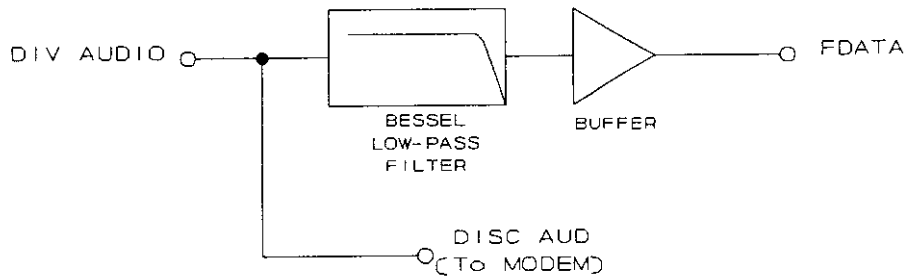

Figure 20. Receive Baseband Processing

Figure 20 is a functional diagram of the receive baseband processing section.

DIVAUDIO (diversity audio) from the diversity reception controller is routed to two separate paths, depending on whether the audio is destined for an external device (control head, external modem, etc.) or for the internal 4-level FSK modem.

DIVAUDIO is routed directly to the internal modem as the modem contains internal filtering of received signals.

For an external device, DIVAUDIO is routed through a 4800 Hz fourth-order Bessel low-pass filter. The primary purpose of the filter is to improve the SNR (Signal to Noise Ratio) of the recovered signal. Secondly, the filter removes any transients induced by the high-speed switching action of the diversity reception controller. Following the filter, the signal is buffered to provide load isolation and is routed to an external device as FDATA (filtered, diversity recovered modulation).

5.8 Power Amplifier Module

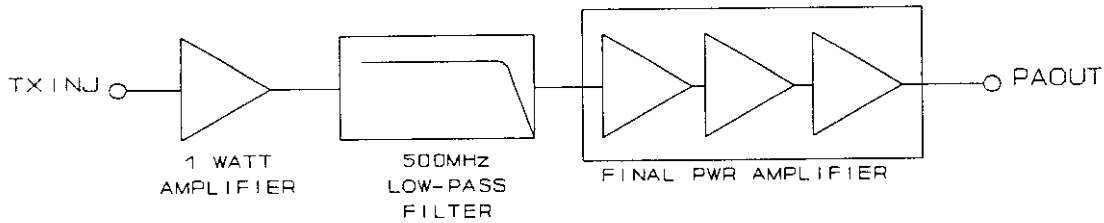

Figure 21. Power Amplifier Functional Diagram

Figure 21 is a functional diagram of the power amplifier. The transmit injection signal from the RF injection section is applied to a 1 watt amplifier. Following the amplifier, a 500 MHz low-pass filter reduces spurious and harmonic emissions. The signal is then routed to the final power amplifier which provides approximately 20 dB of gain, boosting the output signal to 40 Watts. This signal is routed to the T/R switch for transmission.

5.9 T/R (Transmit/Receive) Switch

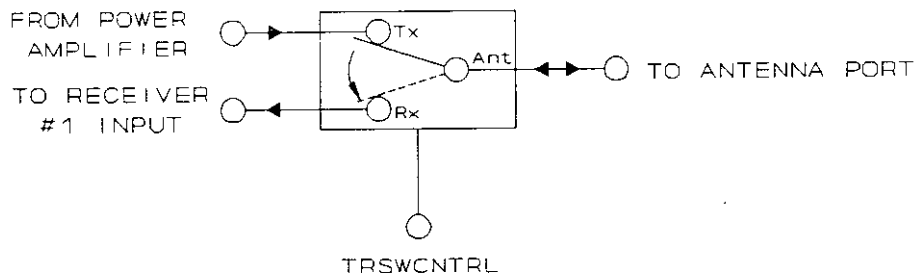

Figure 22. Transmit/Receive Switch Functional Diagram

Figure 22 is a functional diagram of the T/R switch. The T/R switch enables one antenna port to function as both a transmit port and as a receive port. A control signal TRSWCNTRL is used to actuate the switch. The internal configuration of the T/R switch also attenuates even-order harmonics.

6. RECOMMENDED TOOLS AND TEST EQUIPMENT

6.1 Recommended Tools

| Item | ECS Part Number | Note |
|-------------------------|-----------------|--|
| Ceramic tuning tool | 44010006 | used to tune trimmer capacitors and potentiometers |
| Disengagement tool | 44010008 | used to disengage SSMT RF connectors |
| #0 Phillips screwdriver | | used for 0-80 sized screw fasteners on bottom cover |
| #1 Phillips screwdriver | | used for 4-40 screws on and bottom cover and all PCB mounting screws |
| #2 Phillips screwdriver | | used for 40 watt P.A. module removal and replacement |

6.2 Recommended Test Equipment

| Item | Model | Note |
|---------------------------|------------------------|--|
| RF communication test set | HP 8920 or equivalent | used to measure RF output power, frequency error, SINAD, audio level out, distortion, etc. |
| DMM | Fluke 77 or equivalent | used for test point voltage measurements |
| Oscilloscope | 20 MHz BW | audio stage gain measurements |
| DC power supply | 13.8 VDC @ 10 Amps | main DC input power for the DT450 |
| DT Series test box | ECS P/N 502-82030 | convenient test box for miscellaneous test functions |

7 INSTALLATION

7.1 Unpacking and Inspection

Carefully unpack the data radio. It is recommended you verify the items shipped match the items ordered before discarding the packing material. Standard and optional items are listed below. If any damage has occurred during shipment, file a claim with the carrier immediately.

Standard Equipment:

- DT450 Mobile Radio with mounting brackets attached
- Mounting hardware (4 ea number 10 self tapping screws)
- Power cable pigtail with fuse holder and ground lug

Optional Equipment:

- Heavy-duty noise filter
- Microstrip patch antenna

7.2 Installation Instructions

It is recommended the installation be performed by qualified technicians familiar with two-way mobile radio installation procedures. Contact your sales representative for a list of authorized installation facilities in your area.

CAUTION

Automotive Electronics RF Susceptibility - Certain automotive electronic systems such as ABS (Anti-Skid Braking) systems, electronic fuel injection systems, electronic cruise control systems, electronic entertainment systems, etc. may be adversely affected by RF energy during transmit operation of the radio. If radio is to be installed in a vehicle using these types of electronic systems, consult the automobile manufacturer for any precautionary measures required to avoid adverse operation of these electronic systems.

7.2.1 Equipment Requirements

The following equipment is required to perform the installation.

- Electric screw gun for self-tapping screws
- #2 Phillips screwdriver for mounting bracket screws
- Crimping tool for power cable
- Crimping tool for antenna connections

7.2.2 Installation Procedures

Prior to installing the radio, it is recommended you ensure the following conditions are satisfied:

- The radio will be securely mounted in a safe location (ensure the radio will not become a projectile in the event of a collision)
- The radio will be located in an area free from standing water
- The radio will be located in an area easily accessible to the radio technician
- The radio will be located in an area which will not obstruct any automotive mechanisms
- The radio will be installed in a neat and proper fashion

CAUTION

Before installing the self-tapping screws, check the opposite side of the mounting surface and ensure adequate clearance exists for the full length of the screw. Ensure no possibility of penetration into any vital system (brake lines, fuel tank, etc.).

The radio may be mounted vertically or horizontally. The position of the interface connector and the antenna connectors should always be considered carefully (right-angle antenna connectors can reduce the space requirements). Cables should be routed in a manner which ensures the cables will not be pulled or damaged in any way by cargo or passenger feet or any other mechanism.

The supplied quick-disconnect power pigtail has a red lead terminated into one end of an in-line fuse holder; the other end of the fuse holder is left un-terminated. Optional noise filters are recommended. All cabling in the vicinity of the radio should have enough slack to allow the radio to be serviced with the power connected if required. A typical installation diagram is depicted below.

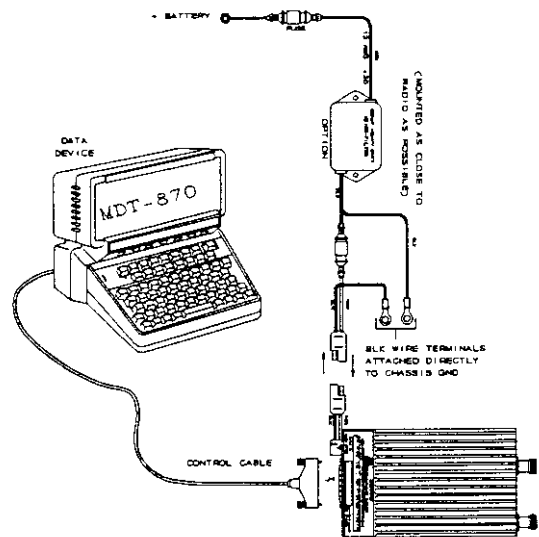

WARNING

FCC regulations require that the frequency and deviation of a transmitter must be checked before it is placed into service and re-checked at one year intervals thereafter.

FCC regulations also state that the RF output power of a radio transmitter shall be no more than that required for satisfactory operation considering the area to be covered and local conditions.

FCC ID number for the DT450 Transmitter: ECSDT450TX

WARNING

Vehicles powered by Liquified Petroleum gas (LP gas) with the gas container in the trunk or other sealed-off space must conform to National Fire Protection Association Standard 58 requiring:

- Space containing radio equipment shall be isolated by a seal from the space containing the LP gas container and its fitting.
 - Outside filling connections shall be used for the LP gas container.
 - The LP gas container space shall be vented to the outside of the vehicle.
-

7.3 Antenna Considerations

In general, the most important part of a radio is the antenna. This is particularly of the dual receiver, dual RF port, DT450. The unique architecture of the DT450 enables considerable operational flexibility; however, closely spaced antennas, and controlled antenna correlation require careful consideration. It is not practical to cover all possible situations; therefore, this section should be used as a guide to proper antenna configuration practices.

7.3.1 Antenna Radiation Pattern

In the mobile environment, the RF energy is as likely to come from one direction as any other. Therefore, an omnidirectional horizontal antenna radiation pattern is required.

An omnidirectional horizontal pattern precludes horizontal gain; therefore, antenna gain must be realized in the vertical dimension. Producing antenna gain in the vertical axis is problematic at the mobile unit.

As the gain of an omnidirectional antenna is increased, the vertical beamwidth is reduced. In areas where line of sight conditions between transmit and receive antennas do not exist, the vertical angle of arrival of energy is as likely to be from one angle as any other (this is especially true of urban areas and areas with heavy topographic relief). In this situation, a high gain antenna (with narrow vertical beamwidth) will not perform as well as a low gain antenna (with a wider vertical beamwidth) because much of the energy is arriving at from an elevation angle in excess of the vertical beamwidth of the high gain antenna. For this reason, antennas with greater than 3 dB gain should not be used in the mobile environment.

7.3.2 Antenna Near-Field Exclusion Zone

For most omnidirectional mobile antennas, as the gain of the antenna is increased, the length of the radiating element is also increased. This becomes problematic when one considers the fact that the antenna near-field exclusion zone (the area surrounding an antenna which must be kept free from objects) is proportional to the square of the length of the longest radiating element. Specifically, in order to avoid antenna radiation pattern perturbations, the area surrounding the antenna must be free from conductive or reflective

objects (including other antennas) by a distance equal to the antenna's near field given by the following formula:

$$F_n = \frac{2*d^2}{\lambda}$$

where: F_n is the near field radius in inches,
 d is the length of the radiating element in inches,
and λ is the wavelength in inches.

For example, a 5 dB gain antenna with a length of 33 inches will require an area free from objects extending 57 inches from the antenna in all directions. Locating two such antennas on the roof of an automobile, with an adequate ground plane surrounding each antenna is not normally possible.

The near-field exclusion zone of a unity gain quarter-wave antenna, with a vertical radiator length of 6.5 inches is less than 3.5 inches. This spacing requirement is easily achievable, but at the cost of 3 dB of gain.

7.3.3 Antenna Correlation Coefficient

One final parameter of concern is related to the separation of diversity reception antennas. The lower the correlation between diversity antennas, the higher the diversity gain. Field tests have determined the separation distance which produces the smallest correlation coefficient is 0.8 wavelengths (21 inches at 450 MHz). Clearly, this is inside the near-field exclusion zone of the 5 dB gain antenna.

7.3.4 Microstrip Patch Antennas

One antenna which satisfies the above criteria quite well is the microstrip patch antenna. A circular patch antenna can produce 3.0 dB gain with the longest radiating element being 5.5 inches. This results in a near-field exclusion zone of only 2.3 inches. This allows the .8 wavelength separation without violating the near-field exclusion zone. The antenna's physical orientation (no vertical radiator) has several other benefits related to protecting the antenna from willful or accidental damage.

8. MAINTENANCE AND ALIGNMENT PROCEDURES

8.1.1 Test Equipment Setup

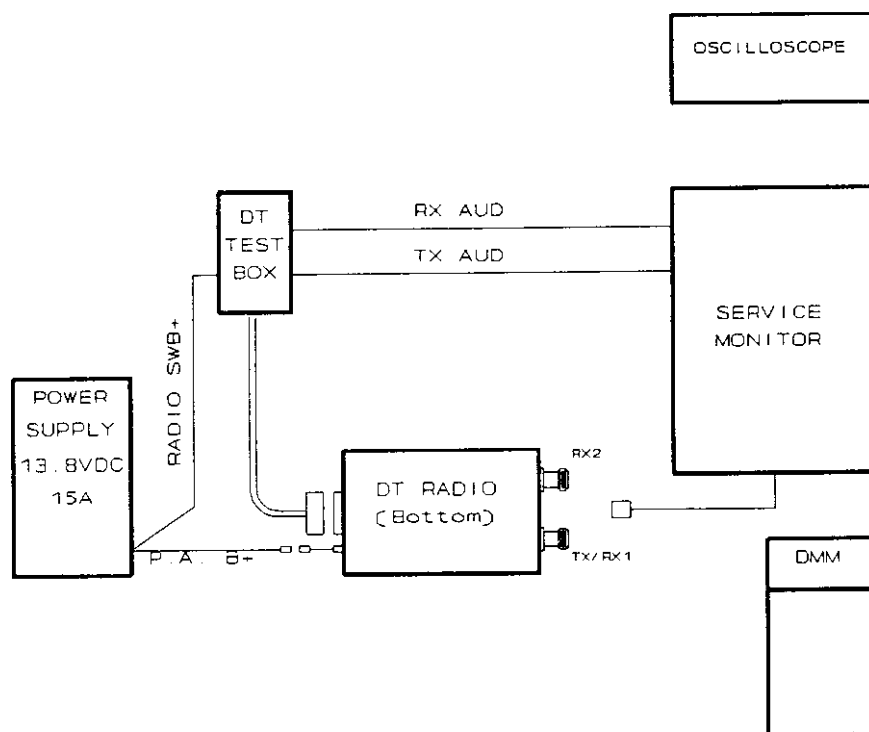

Figure 25. Test Equipment Setup

The typical test equipment setup is illustrated in *Figure 25.* and should be used to perform functional tests and alignment procedures.

It is recommended the troubleshooting flowcharts be used as the first step in verifying proper radio operation.

8.2 RECOMMENDED TOOLS AND TEST EQUIPMENT

8.2.1 Recommended Tools

| Item | ECS Part Number | Note |
|-------------------------|-----------------|--|
| Ceramic tuning tool | 44010006 | used to tune trimmer capacitors and potentiometers |
| Disengagement tool | 44010008 | used to disengage SSMT RF connectors |
| #0 Phillips screwdriver | | used for 0-80 sized screw fasteners on bottom cover |
| #1 Phillips screwdriver | | used for 4-40 screws on and bottom cover and all PCB mounting screws |
| #2 Phillips screwdriver | | used for 40 watt P.A. module removal and replacement |

8.2.2 Recommended Test Equipment

| Item | Model | Note |
|---------------------------|------------------------|--|
| RF communication test set | HP 8920 or equivalent | used to measure RF output power, frequency error, SINAD, audio level out, distortion, etc. |
| DMM | Fluke 77 or equivalent | used for test point voltage measurements |
| Oscilloscope | 20 MHz BW | audio stage gain measurements |
| DC power supply | 13.8 VDC @ 10 Amps | main DC input power for the DT450 |
| DT Series test box | ECS P/N 502-82030 | convenient test box for miscellaneous test functions |

8.3 Transmitter Alignment Procedure

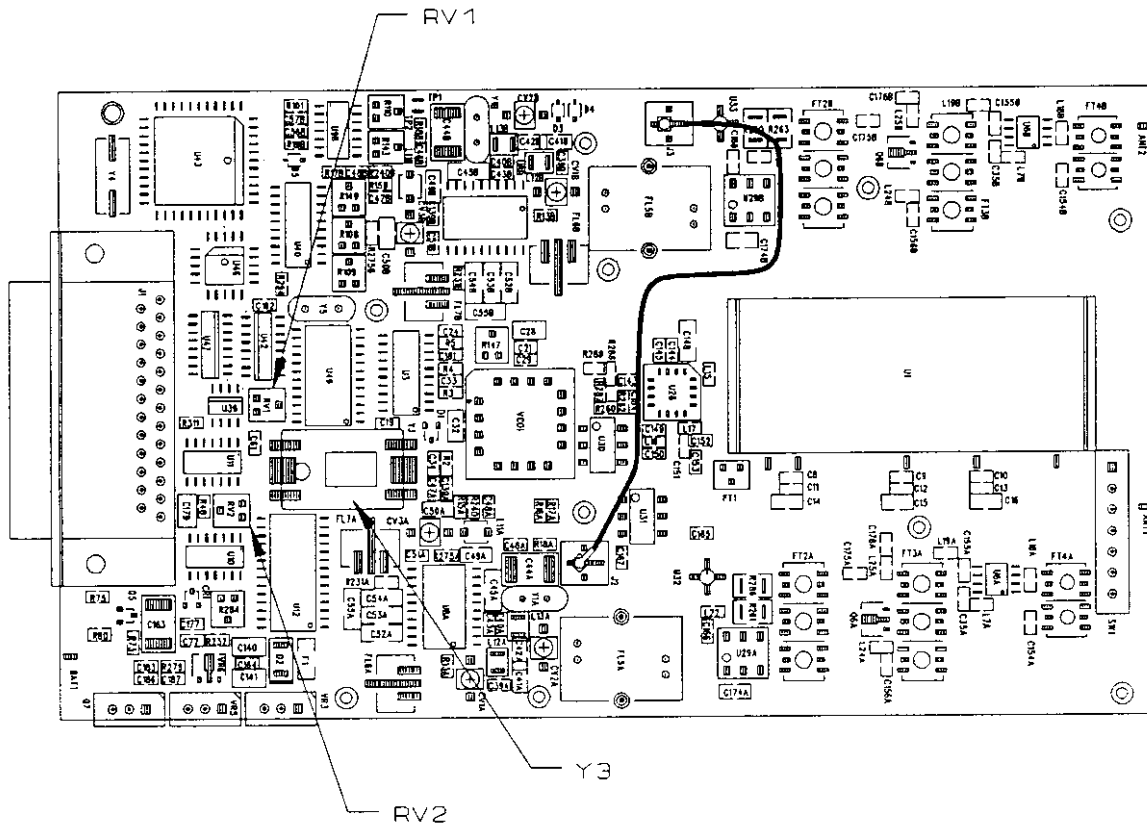

Figure 26. Transmit Adjustment PCB Locations

8.3.1 Injection Frequency Adjustment

- a. Select one of the six radio channels (0, 1, 2, 4, 8, or 16) with the DT series test box and key the radio with the "PTT" switch.
- b. Using ceramic tuning tool, adjust Y3 for minimum frequency error.

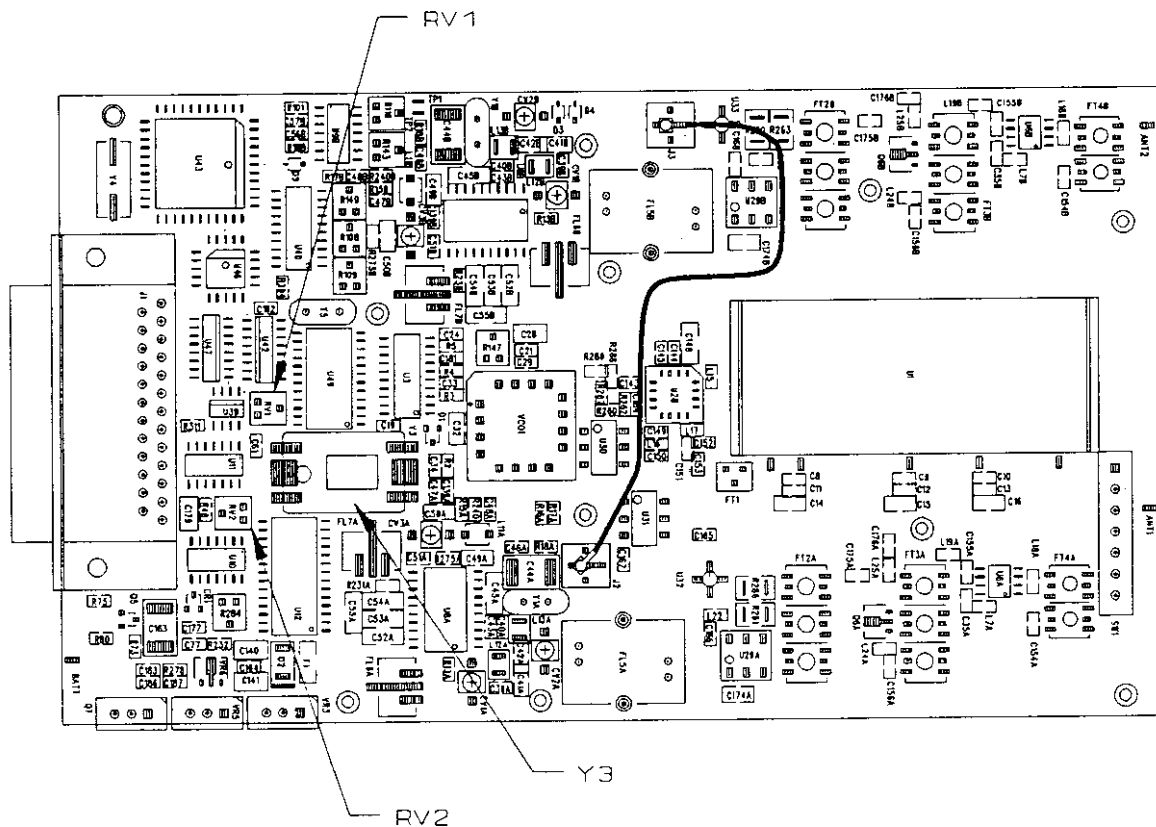

Figure 27. Transmit Adjustment PCB Locations (repeated for reader convenience)

8.3.2 Transmit Modulation Adjustment

- a. Inject a 1.0 Volt peak-to-peak 1.0 kHz audio test tone into "TX AUD" on DT series test box.
- b. While monitoring the service monitor, adjust potentiometer RV2 for required system deviation.
- c. Inject a 1.0 Volt peak-to-peak 100 Hz audio test tone into "TX AUD" on DT series test box.
- d. While monitoring the service monitor, adjust potentiometer RV1 to the same deviation as in step b.

Note: RV1 and RV2 are interactive adjustments; therefore, repeat steps b through e until further adjustments are no longer required.

8.4 Receiver Alignment

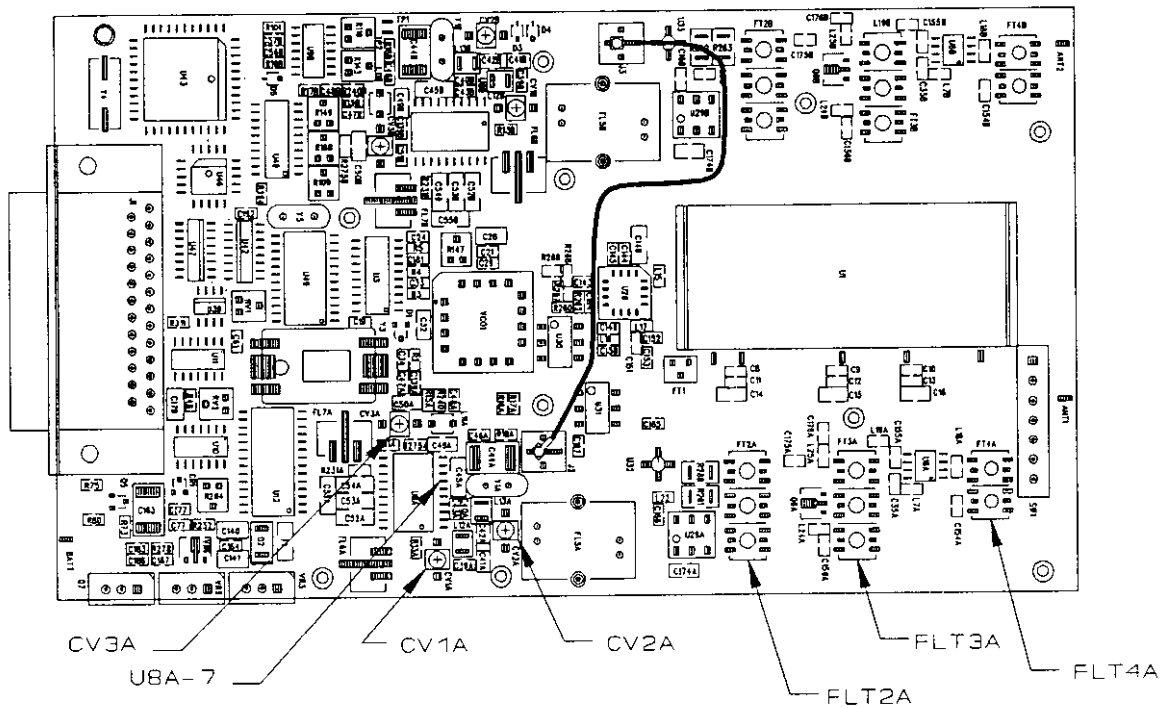

Figure 28. Receiver #1 Adjustment PCB Locations

8.4.1 Receiver #1 Distortion and SINAD Alignment

- Manually select receiver #1 and monitor "RX AUD" using DT series test box.
- Inject an on-frequency RF carrier signal at a level of -80 dBm modulated with a 1.0 kHz test tone at +/- 4.0 kHz into receiver #1 RF port J2.
- Adjust trimmer capacitor CV2A to the center of its tuning range (reference schematic sheet 7).
- Alternately adjust trimmer capacitors CV1A and CV3A for the lowest attainable distortion (3% maximum, 1.5% typical). If distortion can not be adjusted to less than 3%, CV2A may be used to improve the distortion by rotating CV2A +/- 1/4 turn from its center position.

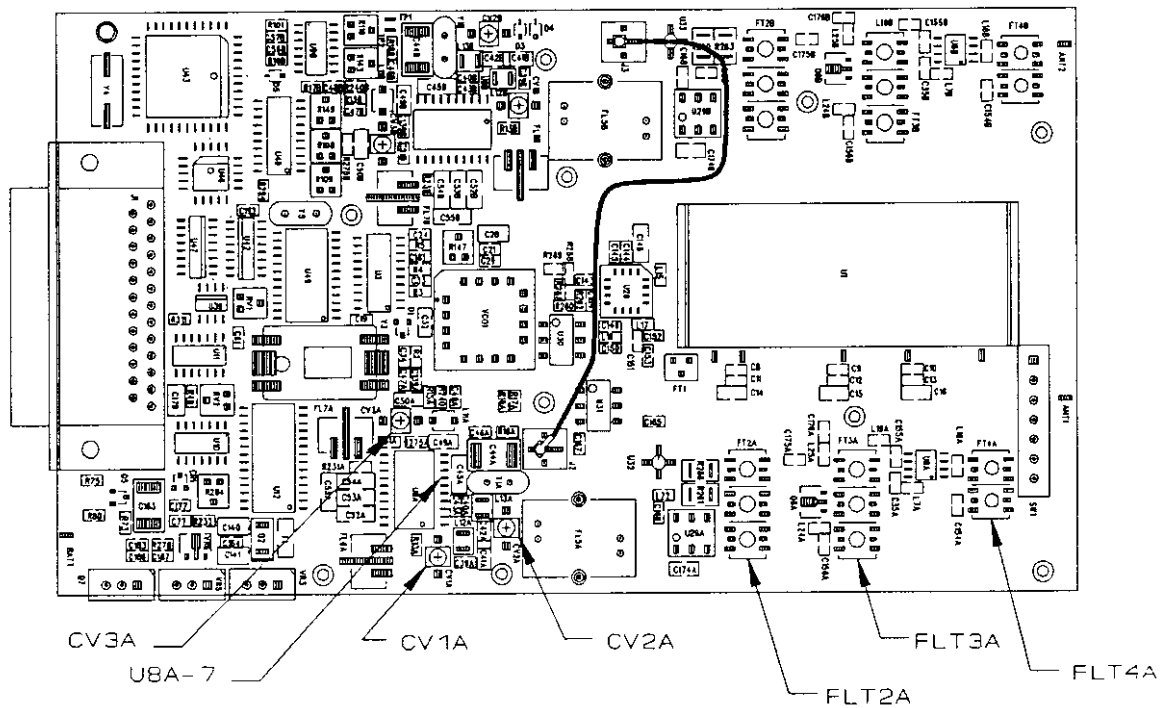

Figure 29. Receiver #1 Adjustment PCB Locations (repeated for reader convenience)

- e. While monitoring the DC voltage at U8A pin 7, carefully adjust FT4A, then FT3A, then FT2A for maximum DC voltage at U8A pin 7 (typically 2.6 VDC).
- f. Reduce the RF level and verify minimum 12 dB sensitivity is within specification.
- g. Record 12 dB SINAD RF level for DRC alignment purposes.

Note: DRC (diversity Reception Controller) alignment procedure Section XXX must be performed after completing the above procedure.

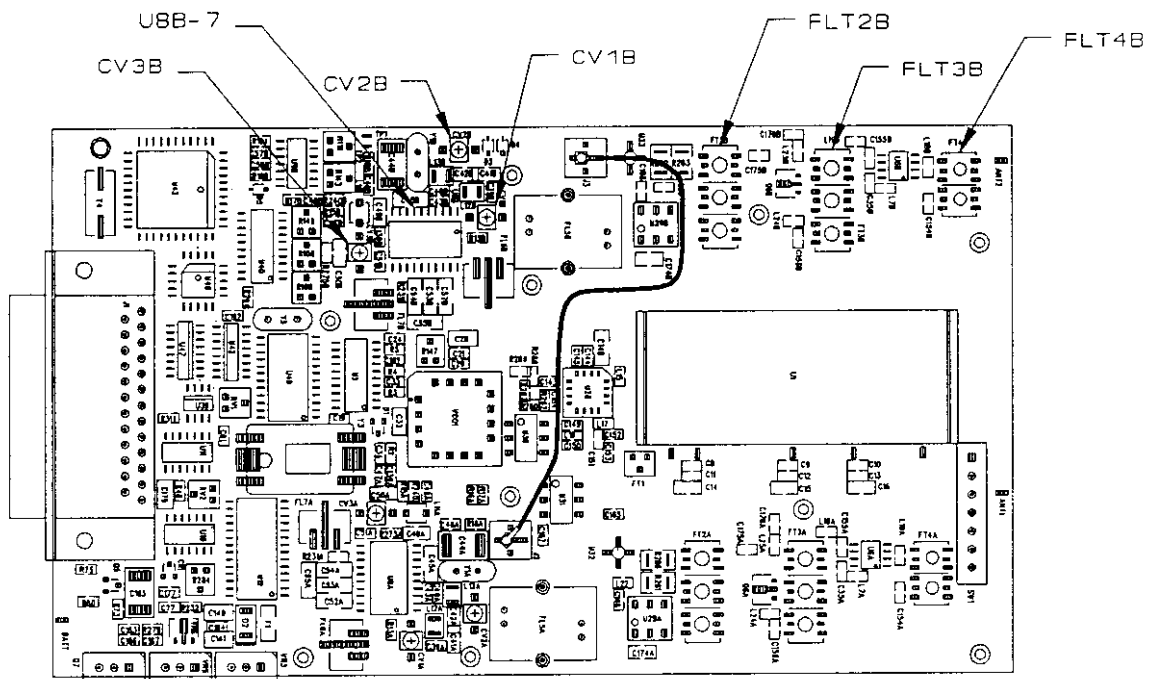

Figure 30. Receiver #2 Adjustment PCB Locations

8.4.2 Receiver #2 Distortion and SINAD Alignment

- a. Manually select receiver #2 and monitor "RX AUD" using DT series test box.
- b. Inject an on-frequency RF carrier signal at a level of -80 dBm modulated with a 1.0 kHz test tone at +/- 4.0 kHz into receiver #2 RF port J3.
- c. Adjust trimmer capacitor CV2B to the center of its tuning range (reference schematic sheet 12).
- d. Alternately adjust trimmer capacitors CV1B and CV3B for the lowest attainable distortion (3% maximum, 1.5% typical). If distortion can not be adjusted to less than 3%, CV2B may be used to improve the distortion by rotating CV2B +/- 1/4 turn from its center position.

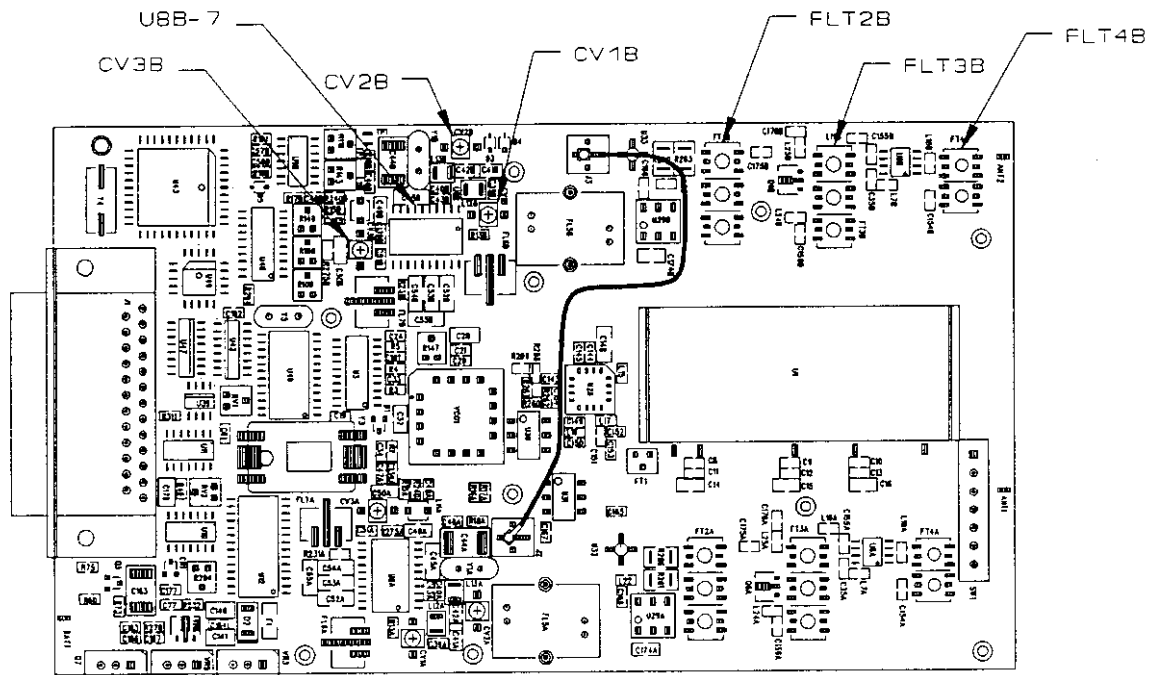

Figure 31. Receiver #2 Adjustment PCB Locations (Repeated for reader convenience)

- e. While monitoring the DC voltage at U8B pin 7, carefully adjust FT4B, then FT3B, then FT2B for maximum DC voltage at U8B pin 7 (typically 2.6 VDC).
- f. Reduce the RF level and verify minimum 12 dB sensitivity is within specification.
- g. Record 12 dB SINAD RF level for DRC alignment purposes.

Note: DRC (diversity Reception Controller) alignment procedure Section XXX must be performed after completing the above procedure.

8.5 Diversity Reception Controller Alignment

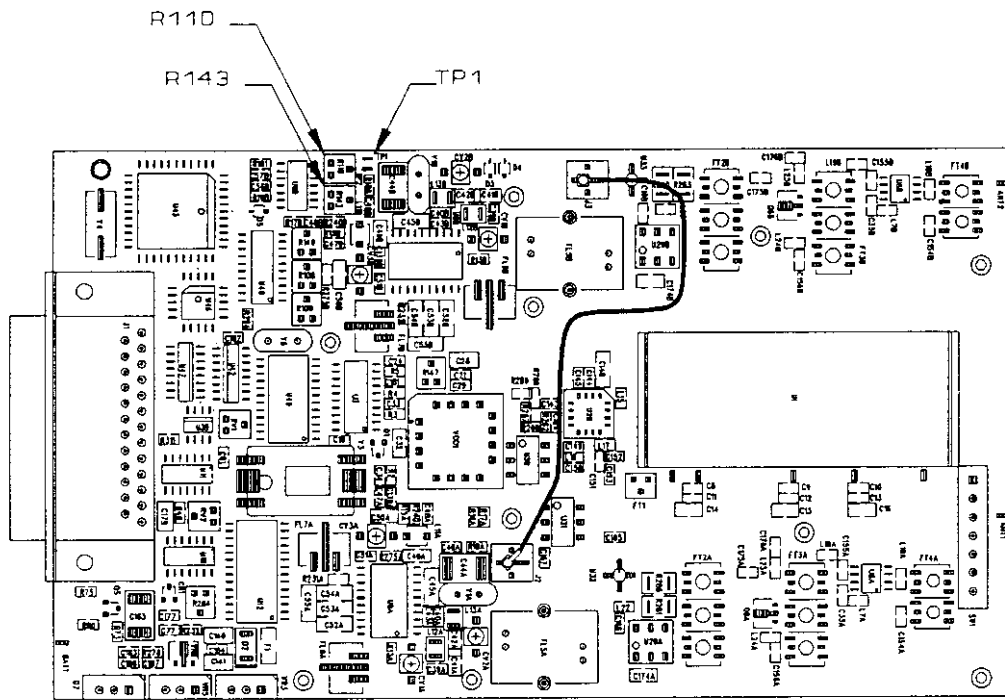

Figure 32. RSSI Alignment for Receiver #1 PCB Adjustment Locations

8.5.1 RSSI Alignment for Receiver #1

Note: Receiver sensitivity must be measured and recorded in order to perform this alignment procedure.

- a. Inject an on-frequency, un-modulated RF carrier to RF port J2 with an amplitude equal to receiver #1's 12 dB SINAD level.
- b. While monitoring TP1, adjust R110 to attain a level of 0.50 VDC at TP1 (reference schematic sheet 13 C7).
- c. Increase the RF carrier amplitude by 50 dBm.
- d. While monitoring TP1, adjust R143 to attain a level of 2.50 VDC at TP1 (reference schematic sheet 13 C7).
- e. Adjustments R110 and R143 are interactive adjustments; therefore, repeat steps a through d until further adjustments are no longer necessary.

8.5.2 RSSI Alignment for Receiver #2

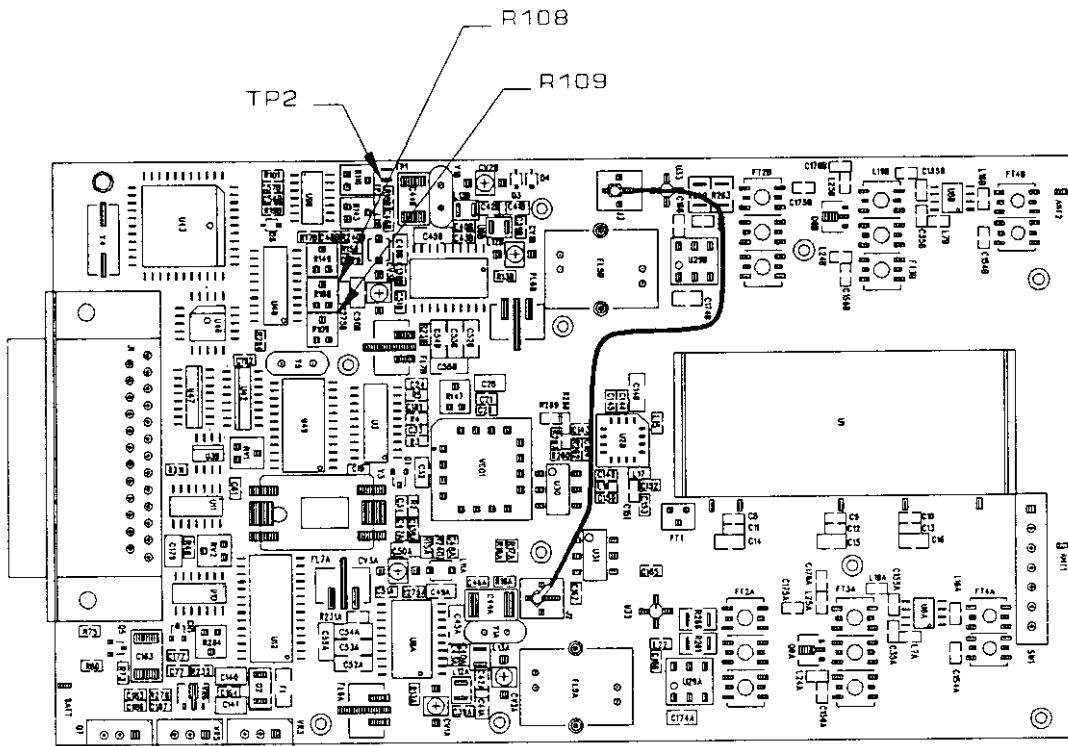

Figure 33. RSSI Alignment for Receiver #2 PCB Adjustment Locations

Note: Receiver sensitivity must be measured and recorded in order to perform this alignment procedure.

- a. Inject an on-frequency, un-modulated RF carrier to RF port J3 with an amplitude equal to receiver #1's 12 dB SINAD level.
- b. While monitoring TP1, adjust R109 to attain a level of 0.50 VDC at TP1 (reference schematic sheet 13 D7).
- c. Increase the RF carrier amplitude by 50 dBm.
- d. While monitoring TP2, adjust R108 to attain a level of 2.50 VDC at TP2 (reference schematic sheet 13 D7).
- e. Adjustments R109 and R108 are interactive adjustments; therefore, repeat steps a through d until further adjustments are no longer necessary.

8.5.3 Receiver Audio Equalization

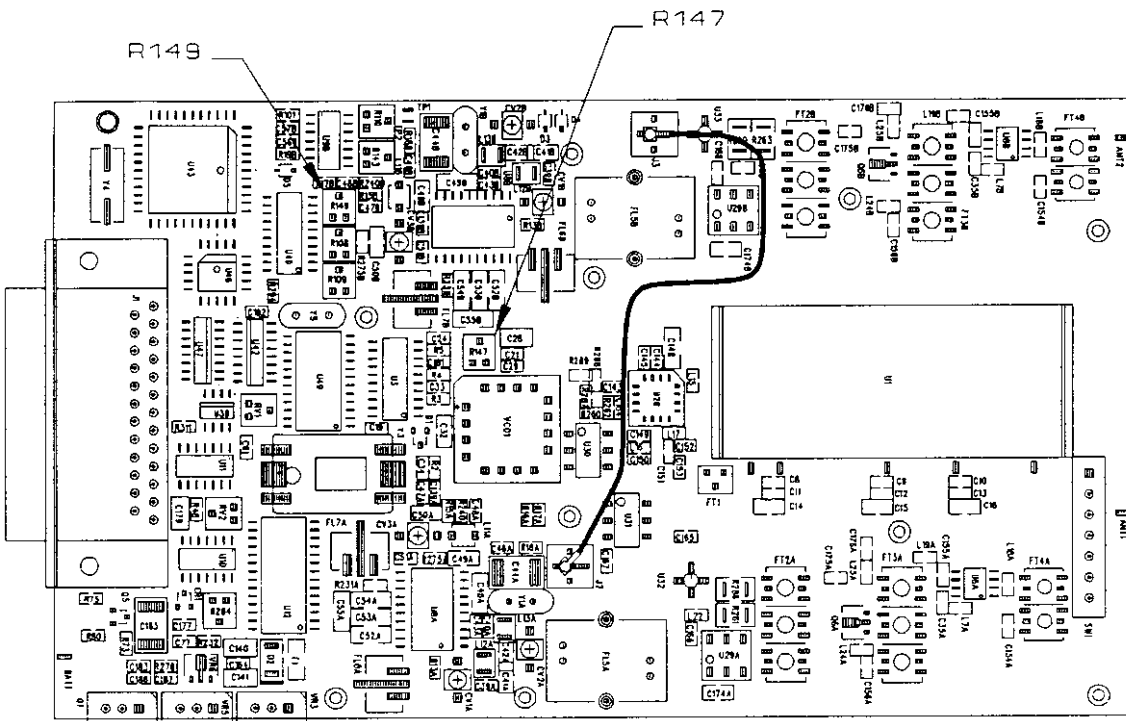

Figure 34. Receiver Audio Level Equalization PCB Adjustment Locations

- a. Using DT series test box, select "auto" and monitor receiver audio at "RX AUD".
- b. Adjust R147 and R149 fully clockwise.
- c. Inject an on-frequency RF signal at a level of -80 dBm, modulated with a 1.0 kHz test tone at a level of +/- 4.0 kHz deviation into RF port J2 (receiver #1).
- d. Record receiver audio level.
- e. Inject an on-frequency RF signal at a level of -80 dBm, modulated with a 1.0 kHz test tone at a level of +/- 4.0 kHz deviation into RF port J3 (receiver #2).
- f. Adjust the higher of the two levels to equal the amplitude of the lower level (adjust R147 for receiver #1 and R149 for receiver #2, reference schematic sheet 13 B3).

9 Troubleshooting Flow Charts

9.1 Transmitter Troubleshooting Flowchart

TRANSMITTER FUNCTIONAL TEST

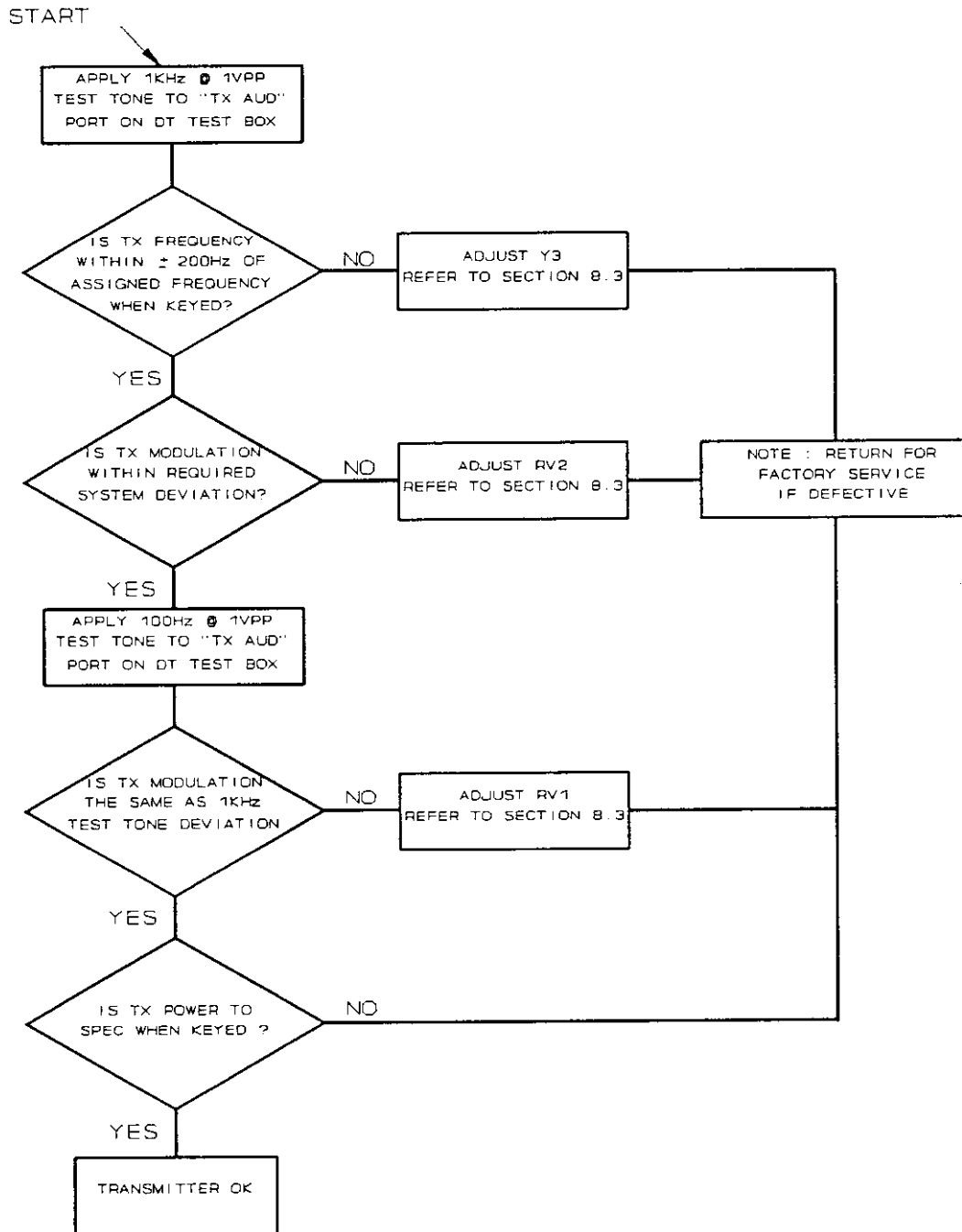

9.2 Receiver Troubleshooting Flowchart

RECEIVER FUNCTIONAL TEST

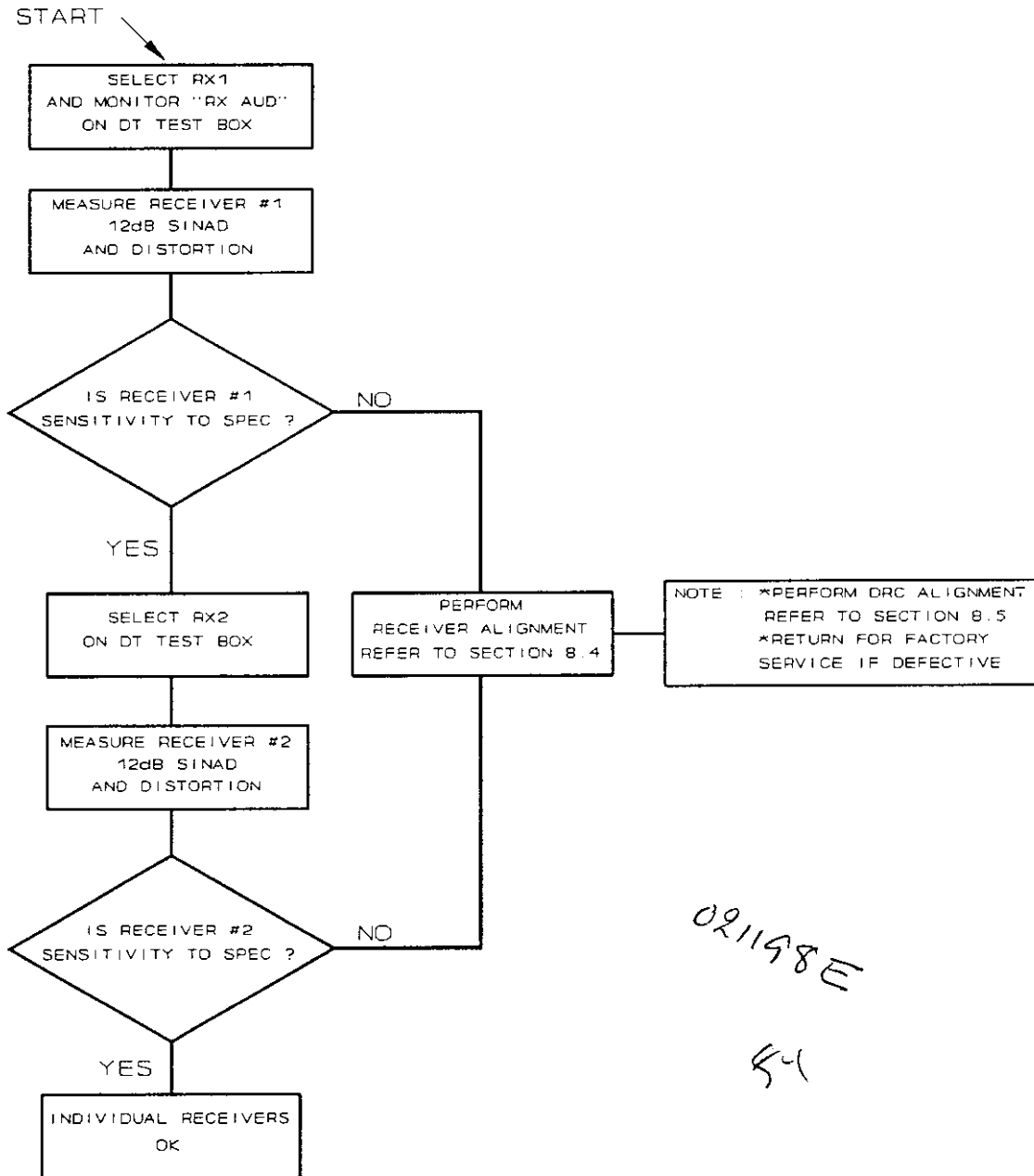

021198E

5-1

9.3 Diversity Reception Controller Functional Troubleshooting Flowchart

DIVERSITY RECEPTION CONTROLLER FUNCTIONAL TEST

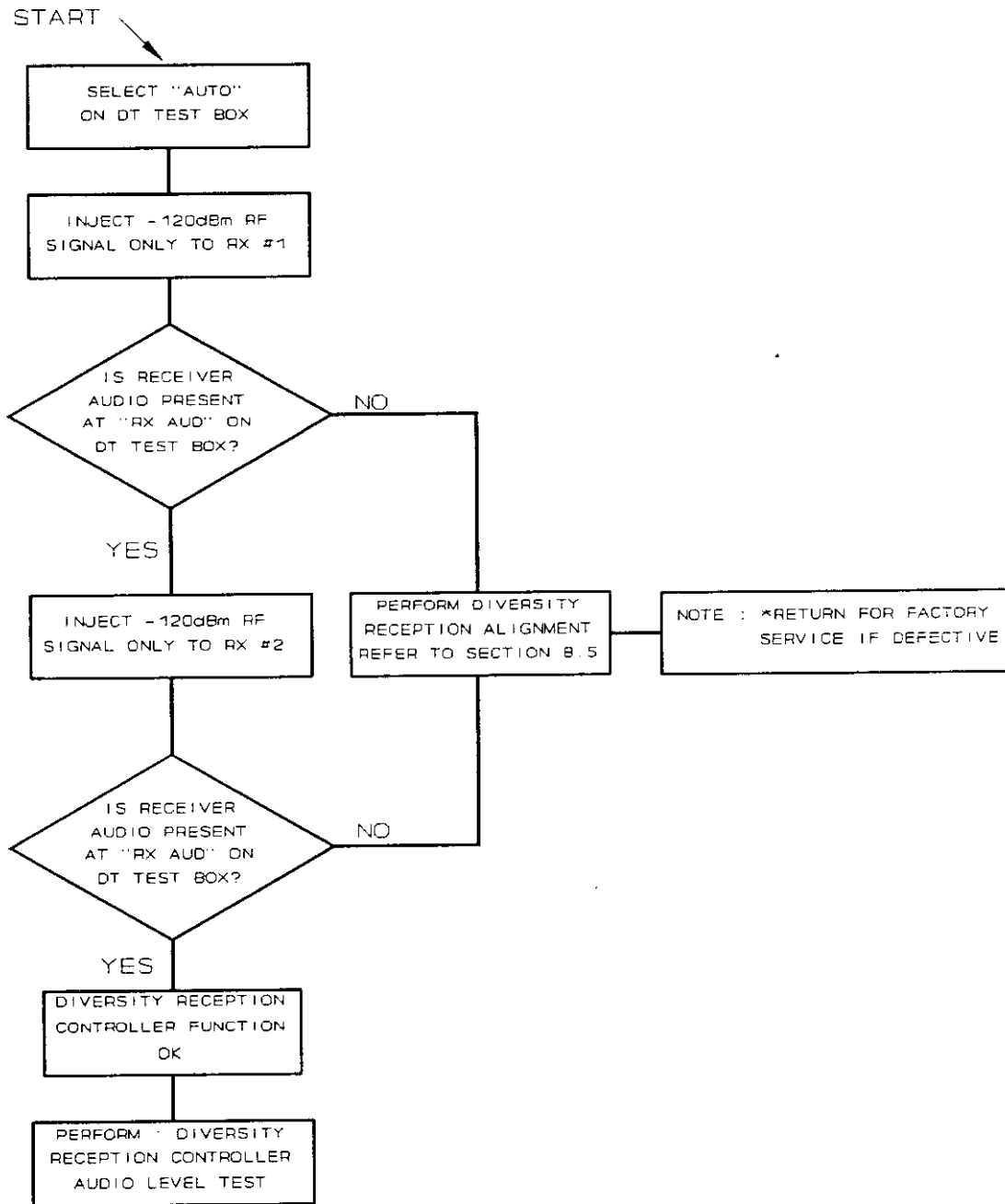

9.4 Diversity Reception Controller Audio Level Troubleshooting Flowchart

DIVERSITY RECEPTION CONTROLLER AUDIO LEVEL TEST

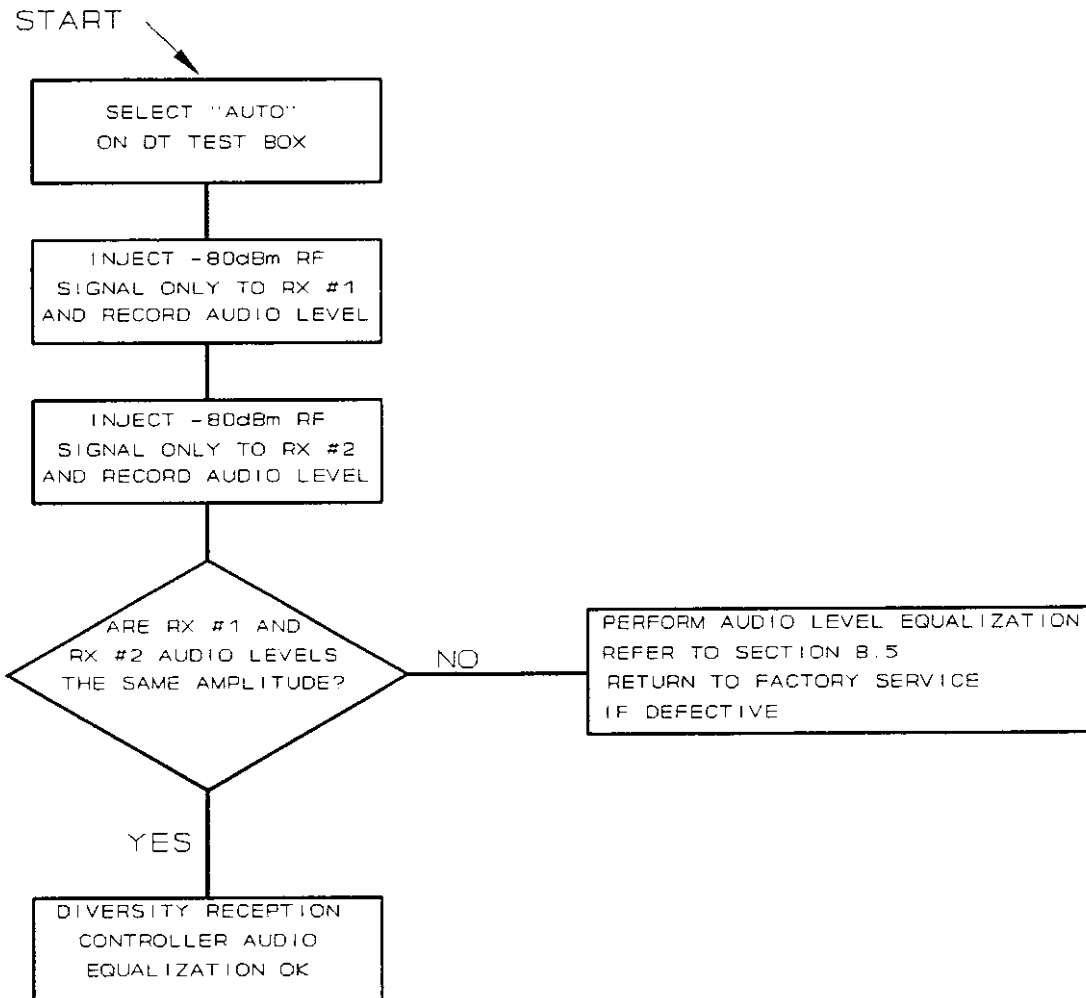

10 GLOSSARY

| | |
|-----------------|---|
| BASEBAND | A signal whose frequency content is centered around DC (or 0 frequency) |
| BESSEL FILTER | A filter with a linear phase response. |
| CMOS | Complementary Metal Oxide Semiconductor - A type of integrated circuit with low power consumption. |
| CPM | Continuous Phase Modulation, a family of modulation schemes in which no phase discontinuities are present. |
| CTCSS | Continuous Tone Coded Squelch System, a sub-audible signalling format which utilizes tones between 67 and 254 Hz. Used primarily to separate different voice systems sharing the same RF channel. |
| DES | DES is the Data Encryption Standard, a block cipher defined and endorsed by the U. S. government in 1977 as an official standard. |
| EEPROM | Electrically Erasable Programmable Read Only Memory |
| EMI | Electromagnetic Interference |
| FM | Frequency Modulation - a form of modulation where the carrier frequency is shifted an amount proportional to the modulating signal's amplitude at a rate proportional to the modulating signal's frequency. |
| FSK | Frequency Shift Key - digital modulation (a form of FM) where the carrier frequency is shifted above and below the operating frequency (in discreet steps) in response to a digital data input. |
| 4-LEVEL FSK | A form of FSK where the carrier frequency is shifted from the operating frequency by 1 of 4 displacement frequencies, 2 above and 2 below the operating frequency |
| IMAGE FREQUENCY | The unwanted sum or difference frequency which occurs naturally in the frequency conversion |

process.

| | |
|--------------|--|
| HALF DUPLEX | A dual frequency mode of operation which inhibits simultaneous transmission and reception. |
| LNA | Low Noise Amplifier |
| NOISE FIGURE | The "Figure of Merit" of an amplifier. Specifically, noise figure is a measure of the degradation in SNR between the input and output ports of a network. |
| PCB | Printed Circuit Board |
| PHASE NOISE | A measure of the purity of a discrete frequency (expressed in -dBc/Hz at some offset frequency) |
| PLL | Phase Locked Loop - a circuit configuration used to lock the frequency of a VCO to a high stability reference oscillator. |
| PPM | Parts Per Million (normally expressed with lower case letters, ppm) |
| PROM | Programmable Read Only Memory |
| RCS | Radio Channel Select |
| RF | Radio Frequency |
| RFI | Radio Frequency Interference |
| SINAD | The ratio of (Signal + Noise + Distortion) to (Noise + Distortion) |
| SMT | Surface Mount Technology - electronic components which make electrical contact on the surface layer of a PCB (as opposed to thru-hole components). SMT devices provide reduced size and increased performance. |
| SNR | Signal to Noise Ratio |
| TCVCXO | Temperature Compensated Voltage Controlled Crystal |

Oscillator

| | |
|----------------------|--|
| TRANSMIT ATTACK TIME | The elapsed time from transmit key assertion to 90% rated RF power is achieved. |
| UHF | Ultra High Frequency, the frequency band from 300 to 3,000 MHz |
| VCO | Voltage Controlled Oscillator - an oscillator whose frequency can be adjusted by a DC control voltage. |
| VGA | Variable Gain Amplifier |