

# INSTALLATION GUIDE

## IP SERIES MOBILE RADIO SYSTEM

**IP Series Mobile Radio**

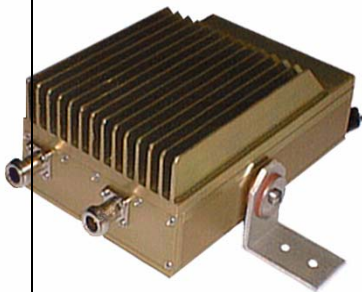

### INSTALLATION GUIDE CONTENTS:

<u>Section Title</u>	<u>Page</u>
▪ IP Series Mobile Radio Illustration.....	2
▪ Installation Overview and Safety Reminder.....	2
▪ Installation Requirements .....	3
▪ Pre-Installation Guidelines .....	5
▪ Mounting the Mobile Radio .....	5
▪ Serial Cable Connection and Routing.....	5
▪ EMI Filter Installation .....	6
▪ Power Supply Installations.....	6
▪ Switch Installation .....	7
▪ Delay Timer Installation .....	7
▪ Antenna Installation .....	8
▪ VIU (Vehicle Interface Unit) Connections .....	9
▪ Testing and Installation Checklist .....	10
▪ Vehicle Unit Wiring Interconnection Layout.....	11
▪ Diversity Antenna Vehicle Installation Detail Diagram.....	12
▪ Mobile Antenna Distance Matrix .....	13
▪ Vehicle Unit Wiring Interconnection Layout with VIU (Voice Interface Unit).....	14
▪ Vehicle Unit Wiring Interconnection Layout with Data911 and VIU (Voice Interface Unit).....	15
▪ Vehicle Unit Wiring Interconnection Layout with Litton Computer and RF Filters.....	16

IPMN p/n: 516-80307

Document Control #: DC-10  
Version: C-3

11909 East Telegraph Road, Santa Fe Springs, CA 90670-3785  
Voice: (562) 946-9493 Fax: (562) 949-0223

Copyright 2001-2002 IPMobileNet, Inc.

Notice:

While reasonable efforts were made to ensure that the information in this document was complete and accurate at the time of printing, IPMobileNet, Inc. can assume no responsibility for any inaccuracies. Changes and corrections to the information within this document may be incorporated into future releases.

## IP Series Mobile Radio Illustration

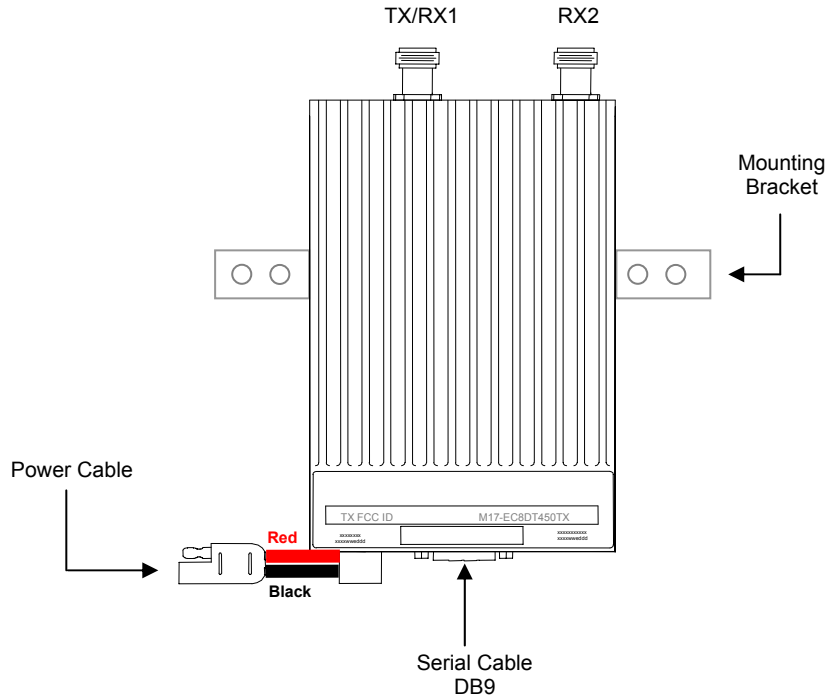

### Installation Overview

This guide will provide standard steps involved in the installation process of an IP Series Mobile Radio. This guide includes wire routing and connections between the radio, other components, and the vehicle's power.

### Safety Reminder

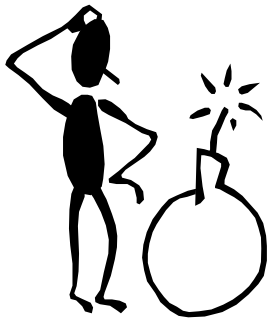

1. To prevent personal injury and vehicle damage, exercise extreme caution throughout this installation process.
  - Follow safety precautions for handling wiring, tools, and a vehicle's engine.
  - Handle the vehicle's battery with extreme caution to avoid burns.
  - Do not alter the components listed in the Installation Requirements on page 3 unless substitutions are noted within this document.
  - Once the antennas are installed, as directed within this guide on page 8 of 15, all persons must maintain a distance of no less than 39 inches from the antennas.

# INSTALLATION REQUIREMENTS

**PL502-82019-51 - MOBILE ACCESSORY KIT -- A Mobile Radio includes the following components (part of mobile top assembly):**

Qty	Description	IPMN Part Number
1	Cable, Power Extension	502-82020-53
2	'L' Brackets	50026749
2	Screws Skt Cap Button Head 10-32 X 5/8	37081032-10
6	Washers Split Lock #10	271-0062-010
2	Washers Fender 1" O.D. X .28 I.D. X .05 THK	271-0059-001
4	Washers Rubber 1" O.D. X .65 I.D. X .12 THK	36040001
2	Hoses, Rubber Black .380 O.D. X .191 I.D. X .3	34010295
4	Screws Self-Tapping #10 X 5/8	37040010-10
0	Installation Manual	516-80307
0	Technical Manual	516-82025

**PL502-80208-51 - INSTALLATION KIT – The following components are required for a Mobile Radio Installation and are available for purchase through IPMobileNet, Inc.**

Qty	Description	IPMN Part Number
1	EMI Filter	127-0020-001
1	Timer, 2 hours	150-0127-001
1	Relay	128-0117-001
1	Relay Socket	128-0116-001
2	Butt Connectors #8 AWG	120-0256-001
1	Terminal, Ring #8 AWG, #10 Screw Insulated	120-0127-001
4	Terminal, Ring #18-22 AWG, #10 Screws Insulated	120-0250-004
4	Terminal, Ring #10-12 AWG, #10 Screws Insulated	120-0250-005
4	Terminal, Disconnect #14-16 F	120-0244-002
18	Terminal, Disconnect #10-12 F	120-0244-003
2	Disconnect Tab, Quad Male	200-1377-001
1	Wire, 12 AWG Black, order 5 ft.	156-0242-001
1	Wire, 12 AWG Red, order 44 ft.	156-0242-003
1	Fuse, 30 AMPS ATO	122-0042-001
1	Fuse Holder, 30 AMPS	120-0253-001
1	Switch, Toggle DPST	144-0136-001
1	Diagram, Mobile Installation without VIU	502-80259
1	Diagram, Mobile Installation with VIU	502-80260
1	Diagram, Mobile Installation with Data 911 and VIU	502-80306
1	Diagram, Litton Interconnection with RF Filters	VEH-01-0503

## OPTIONAL INSTALLATION SUPPLIES – Order each item individually:

Qty	Description	IPMN Part Number
1	Serial Cable (DB9MF), 20 ft.	156-0245-020
1	Wire, 8 (133/29) AWG VW-1 Red, by foot, order 19.5 ft.	156-0243-003
1	Wire, 8 (133/29) AWG VW-1 Black, by foot, order 19.5 ft.	156-0243-001
2	RG58U Cable and Mount, VHF, 17 ft. (incl 3/4" Brass Mount and N Male Crimp)	102-0200-001
2	RG8X Cable and Mount, UHF & 800 MHz, 17 ft. (incl 3/4" Brass Mount & N Male Crimp)	102-0200-002
2	Antenna, Radome Type, 142-164 MHz, Unity Gain (requires 1 MB8UN for ea antenna)	102-0205-001
2	Antenna, Radome Type, 150-174 MHz, Unity Gain (requires 1 MB8UN for ea antenna)	102-0205-002
2	Antenna, Radome Type, 410-430 MHz, 3dB Gain (requires 1 MB8XN for ea antenna)	102-0206-001
2	Antenna, Radome Type, 430-450 MHz, 3dB Gain (requires 1 MB8XN for ea antenna)	102-0206-002
2	Antenna, Radome Type, 450-470 MHz, 3dB Gain (requires 1 MB8XN for ea antenna)	102-0206-003
2	Antenna, Radome Type, 470-490 MHz, 3dB Gain (requires 1 MB8XN for ea antenna)	102-0206-004
2	Antenna, Radome type, 806-866 MHz, 3dB Gain (requires 1 MB8XN for ea antenna)	102-0207-001
2	Antenna, Radome Type 821-896 MHz, 3dB Gain (requires 1 MB8XN for ea antenna)	102-0207-002
2	Antenna, 5/8 Wave, 406-430 MHz, 3dB Gain (requires 1 MB8XN for ea antenna)	102-0199-003
2	Antenna, 5/8 Wave, 430-450 MHz, 3dB Gain (requires 1 MB8XN for ea antenna)	102-0199-004
2	Antenna, 5/8 Wave, 450-470 MHz, 3dB Gain (requires 1 MB8XN for ea antenna)	102-0199-005
2	Antenna, 5/8 Wave, 470-490 MHz, 3dB Gain (requires 1 MB8XN for ea antenna)	102-0199-002
2	Antenna, 5/8 Wave 490-512 MHz, 3dB Gain (requires 1 MB8XN for ea antenna)	102-0199-006
2	Antenna, 5/8 Wave, 806-866 MHz, 3dB Gain (requires 1 MB8XN for ea antenna)	102-0199-001
2	Antenna, 1/4 Wave, 136-144 MHz, Unity Gain (requires 1 MB8UN for ea antenna)	102-0204-001
2	Antenna, 1/4 Wave, 144-152 MHz, Unity Gain (requires 1 MB8UN for ea antenna)	102-0204-002
2	Antenna, 1/4 Wave, 152-162 MHz, Unity Gain (requires 1 MB8UN for ea antenna)	102-0204-003
2	Antenna, 1/4 Wave, 162-174 MHz, Unity Gain (requires 1 MB8UN for ea antenna)	102-0204-004
2	Antenna, 1/4 Wave, 406-430 MHz, Unity Gain (requires 1 MB8XN for ea antenna)	102-0204-005
2	Antenna, 1/4 Wave, 430-450 MHz, Unity Gain (requires 1 MB8XN for ea antenna)	102-0204-006
2	Antenna, 1/4 Wave, 450-470 MHz, Unity Gain (requires 1 MB8XN for ea antenna)	102-0204-007
2	Antenna 1/4 Wave, 470-490 MHz, Unity Gain (requires 1 MB8XN for ea antenna)	102-0204-008
2	Antenna, 1/4 Wave, 490-512 MHz, Unity Gain (requires 1 MB8XN for ea antenna)	102-0204-009
2	Antenna, 1/4 Wave, 806-896 MHz, Unity Gain (requires 1 MB8XN for ea antenna)	102-0204-010

# INSTALLATION INSTRUCTIONS

## Pre-Installation Guidelines

1. Prior to installing new equipment, remove existing equipment and all related components to include stock clips on radio wiring harness and antenna.
2. Mounting of the radio, delay timer, relay, and filter will take place in the trunk compartment (see Fig. 1) unless installing in a vehicle without a trunk.

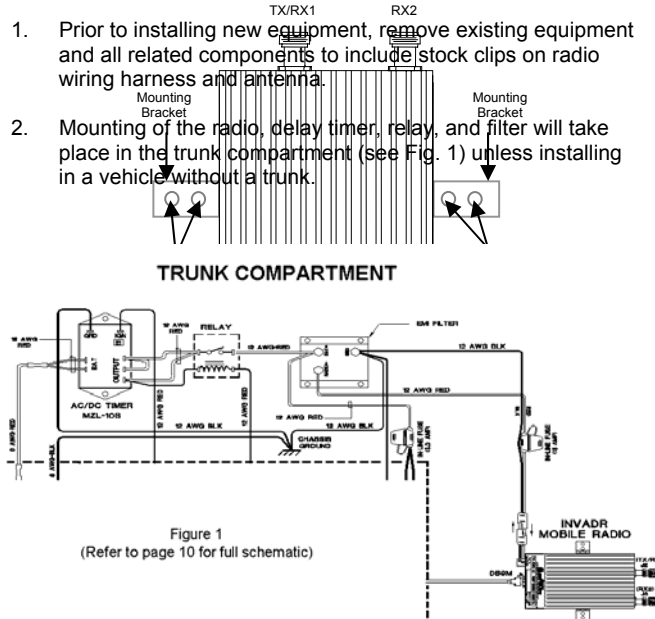

**NOTE:** Removal of seats, rubber mats, and other obstructions, from inside the driver compartment, may be necessary to facilitate routing of wires to the engine and trunk compartments.

3. To ensure appropriate cable and wire routing, exercise the following precautions:
  - Route cables away from sharp edges that can penetrate cable insulation and damage wires.
  - Protect wires with silicone rubber grommets when routing through the engine compartment firewall or through other holes with sharp edges.
  - Use high-quality electrical tape when covering exposed wires in the engine compartment.
  - Avoid routing cables through areas exposed to extreme heat, such as the exhaust system.
  - Keep wires routed through the engine compartment away from hot and/or moving parts.
4. Prior to drilling holes in the engine compartment firewall, inspect both sides to avoid obstructions.
5. For grounding point, use the engine block or the negative (-) terminal of the vehicle battery. Ground connection surfaces must be free of paint, rust, and other corrosion to maximize performance and avoid damage.
6. To simplify troubleshooting problems, label all connecting points and wires.

## Mounting the Mobile Radio

To mount the radio, perform the following steps:

- Step 1** Secure the radio into the trunk compartment. Insert four (4) sheet metal screws in the radio brackets; two (2) screws on either side of the radio (see Fig. 2).



### CAUTION:

If less than four (4) screws are used, the radio can become loose in the trunk compartment. This may cause the radio not to function properly.

When inserting screws, be careful not to disturb the vehicle gas tank.

## Serial Cable Connection and Routing

(IPMN p/n: 156-0245-020)

The serial cable connects the radio to the Mobile Data Computer (MDC) located in the driver compartment.

To connect the serial cable, perform the following steps:

- Step 1** Attach the 20-foot serial cable male connector (DB9M – see Fig. 3) to the radio.

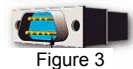

- Step 2** Route the female connector (DB9F – see Fig. 4) to the driver compartment and connect to the serial port located on the rear of the MDC.

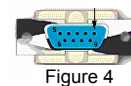

**NOTE:** Route the serial cable to minimize foot pressure and other potential stresses. Use split loom tubing and nylon cable ties for cable protection.

(If connecting a Voice Interface Unit, see page 9 for instructions).



## Carling Switch Installation (DPST Heavy Duty Toggle) (IPMN p/n: 144-0136-001)

To install the switch, perform the following steps:

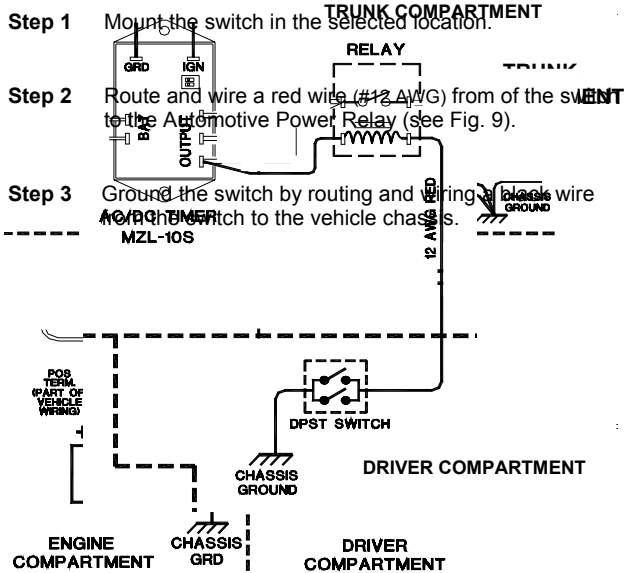

Figure 9

**NOTE:** Install switch in a location convenient to the driver ensuring that the switch cannot be inadvertently moved to the Off position.

## Delay Timer Installation (IPMN p/n: 150-0127-001)

To install the Delay Timer, perform the following steps:

- Step 1** Secure Delay Timer to the trunk compartment of the vehicle.
- NOTE:** When inserting screws be careful not to puncture the vehicle gas tank.
- Step 2** Route the black wire (#12 AWG) from ground connection on the Delay Timer to the vehicle chassis (see Fig. 10).
- Step 3** Route and wire red wire (#8 AWG) from the positive (+) terminal connection on the vehicle battery connection via a 30 AMP in-line fuse toward the battery connection on the Delay Timer.
- Connect the red wire (#8 AWG) to the two red wires (#12 AWG). Route and wire the red (#12 AWG) wires to the two (2) battery connections on the Delay Timer.

Figure 10

- Step 4** Route a red wire (#12 AWG) from the ignition connection on the Delay Timer to the ignition switch in the driver compartment (see Fig. 10).
- Step 5** Route a red wire (#12 AWG) from the first and last output connections on the Delay Timer to the Automotive Power Relay.
- Step 6** Route and wire a red (#12 AWG) wire from the second output connection on the Delay Timer to the last output connection on the Delay Timer.
- Step 7** Route and wire a red (#12 AWG) wire from the last output connection on the Delay Timer to the Automotive Power Relay coil at the position shown in Figure 10.
- Step 8** Route and wire a black (#8 AWG) wire from the vehicle chassis in the trunk compartment to the negative (-) terminal on the vehicle battery.

# Antenna Installation



Two (2) antennas are mounted and installed on the roof of the vehicle using specific measurements for distance.

and install the antennas, perform the following steps:

**Step 1** Install antennas (see sample drawing DT450-10-0201 and Fig. 11 below).

The separation distance between the two (2) antennas is 19". The preferred is 31.25".

The minimum distance of the RX2 antenna from the light bar is 3.2".

Observe correct separation between antennas (refer to the Mobile Antenna Distance Matrix for midpoint distance calculations on page 12) and minimum Near Field Exclusion Zone (NFEZ) for proper diversity reception operation.

**Step 2** Cut a mounting hole in the roof of the vehicle using an electric drill or hole saw.

**NOTE:** The antenna-mounting hole provides ground connection to the antenna. Ensure that a metal-to-metal connection between the antenna shields exists.

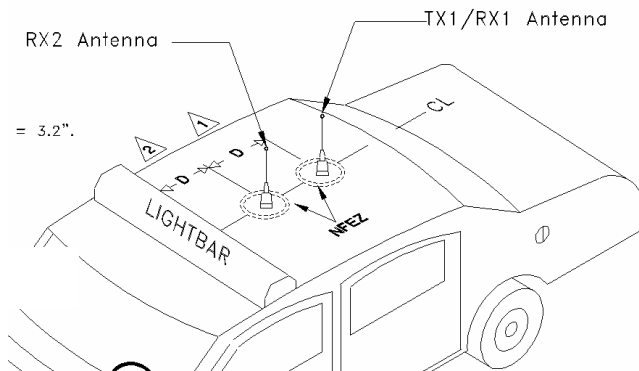

Figure 11

**NOTE:** Figure 11 represents the recommended front-to-rear antenna installation. The receiver antenna (RX2) should be the antenna nearest to the light bar.

**Step 3** All antenna mounts must be environmentally tight. Install or use O-rings to seal the antenna base to the rooftop of the vehicle.

**Step 4** Route the coaxial cables to the radio through one of the hollow spaces in the roof supports into the trunk compartment where the radio is mounted.

**NOTE:** Both antennas should be checked and tested to ensure they are functioning properly.

If these installation guidelines are followed, it is safe for persons to stand at a distance no less than 39 inches from the antennas.

**NOTE:** The following test is performed without any power, thus can be performed immediately after the installation of the coax and antenna, following the installation of the N-type connector on the coax.

To measure Return Loss, perform the following steps:

**Step 1** Select one of the following Antenna Analysts to perform the test:

- 450 to 508 MHz installations, use the 140-525 Analyst
- 806 to 960MHz installations, use the CellMate Analyst

**Step 2** Connect the antenna to be tested to the Antenna Analyst.

**Step 3** Turn on the Antenna Analyst and the Return Loss (RETL) is displayed in dB to the left of the Voltage Standing Wave Ratio (VSWR) curve.

**NOTE:** The Return Loss Specification is -14 dBm or greater (with good antennas the typical range will be between -14 and -28).

To measure the Voltage Standing Wave Ratio (VSWR) Reflected Power, perform the following steps:

**Step 1** After selecting the appropriate Analyst and connecting the antenna to be tested, press **F1** to access the Analyst Menu.

**Step 2** Press **F1** again to access the Display (DSPLY) menu, which lists the modes.

**Step 3** Press **F2** to select the VSWR display mode. Plotting will resume and the VSWR value is highlighted.

**NOTE:** The VSWR Reflected Power Specification is 1.6 watts or less.

To measure Insertion Loss of an unterminated length of coax, perform the following steps:

**Step 1** Connect the antenna to be tested to the appropriate Antenna Analyst.

**Step 2** Turn on the Antenna Analyst and the Return Loss is displayed in dB to the left of the VSWR curve.

**NOTE:** To switch from the RETL mode to VSWR mode, refer back to the previous set of instructions.

**Step 3** Divide the result by two (2).



## VIU Connections

If connecting a VIU, an additional serial cable is required.

- 10-ft serial cable (part number: 156-0245-010) included with VIU

To connect the serial cables, perform the following steps:

- Step 1** Attach 20-ft serial cable male connector (DB9M) to the radio.
- Step 2** Route the female connector (DB9F) to the driver compartment and connect to the serial port located on the rear of the VIU near the microphone hang up clip.
- Step 3** Attach the 10-foot serial cable male connector (DB9M) to the other serial port located on the rear of the VIU.
- Step 4** Route the female connector (DB9F) serial cable to the serial port located on the rear of the MDC.

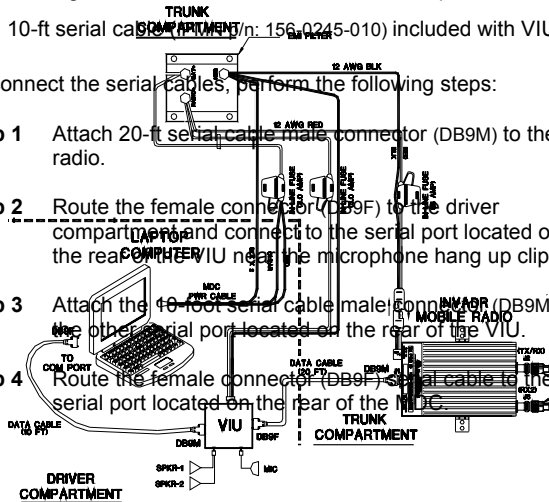

Figure 12

To connect the VIU power supply, perform the following steps:

- Step 1** Route the VIU's power supply cable from the driver compartment to the trunk compartment.
- Step 2** Connect the black (#18 AWG) wire from the VIU power cable to the negative (-) terminal on the EMI Noise Filter.
- Step 3** Attach the red (#18 AWG) wire of the VIU power cable via the 3 AMP in-line fuse to the radio connection on the EMI Noise Filter.

Figure 13

## Mobile Radio Testing

1. To verify that the Mobile Radio setup works properly, use a wattmeter and a service monitor.

**NOTE:** If a wattmeter and a service monitor are not available, begin test from Step 3 through 6 and 10 through 12.

2. Connect the wattmeter between the radio and the coax connector.
3. Connect the radio to a computer with the IPMobileNet IP Message Utility program loaded. See the following documents for further details:
  - *Mobile Data Computer for Communication with the IP Series Mobile Radio – IPMN p/n: 516-80310*
4. Double click on the **SLIP2IPMN** icon to start the dial-up connection.
5. Double click on the **IP Message** shortcut.
6. In the **To:** field, enter the radio's **IP address** and click on the **Send** button and the radio's configuration will list in the upper message screen.
7. Tune the service monitor to the assigned transmitter frequency.
8. On the computer, in the lower message screen of the IP Message Utility, type **unlock=password** (entering the appropriate password to unlock the radio).
9. In the lower message screen, type **x=2000, 19** and click on the **Send** button to key the transmitter and measure the forward power and reflected power.
10. Measure the transmitted frequency and the modulation level.
11. At the computer, using the IP Message Utility program, in the lower message window, type **V** and click on the **Send** button to enable verbose.
12. Ping the IPNC via MS-Dos using the following command:

**Ping (IPNC IP address) -n 20 -l 500**

Performance statistics showing TX data, RX data quality (DQ) and signal levels (RSSI) will display on the IP Message window.

## Installation Checklist



Throughout the installation process and once the installation is complete, make sure to perform the following tasks:

- Thoroughly scope out the vehicle to find any obvious problem areas.
- Check wiring for safety concerns.
- Use tie wraps to ensure that all wires routed in parallel are bundled together.
- Check to see if any wires are exposed.
- If any wires are exposed, use electrical tape to cover.

**REMINDER:** When covering wires in the engine compartment, use high-quality electrical tape.

- Perform appropriate testing as described in this guide to ensure radio works properly.
- Once installation is completed, remove all debris and restore dismantled parts and rubber mats to appropriate locations.

# VEHICLE UNIT WIRING INTERCONNECTION LAYOUT

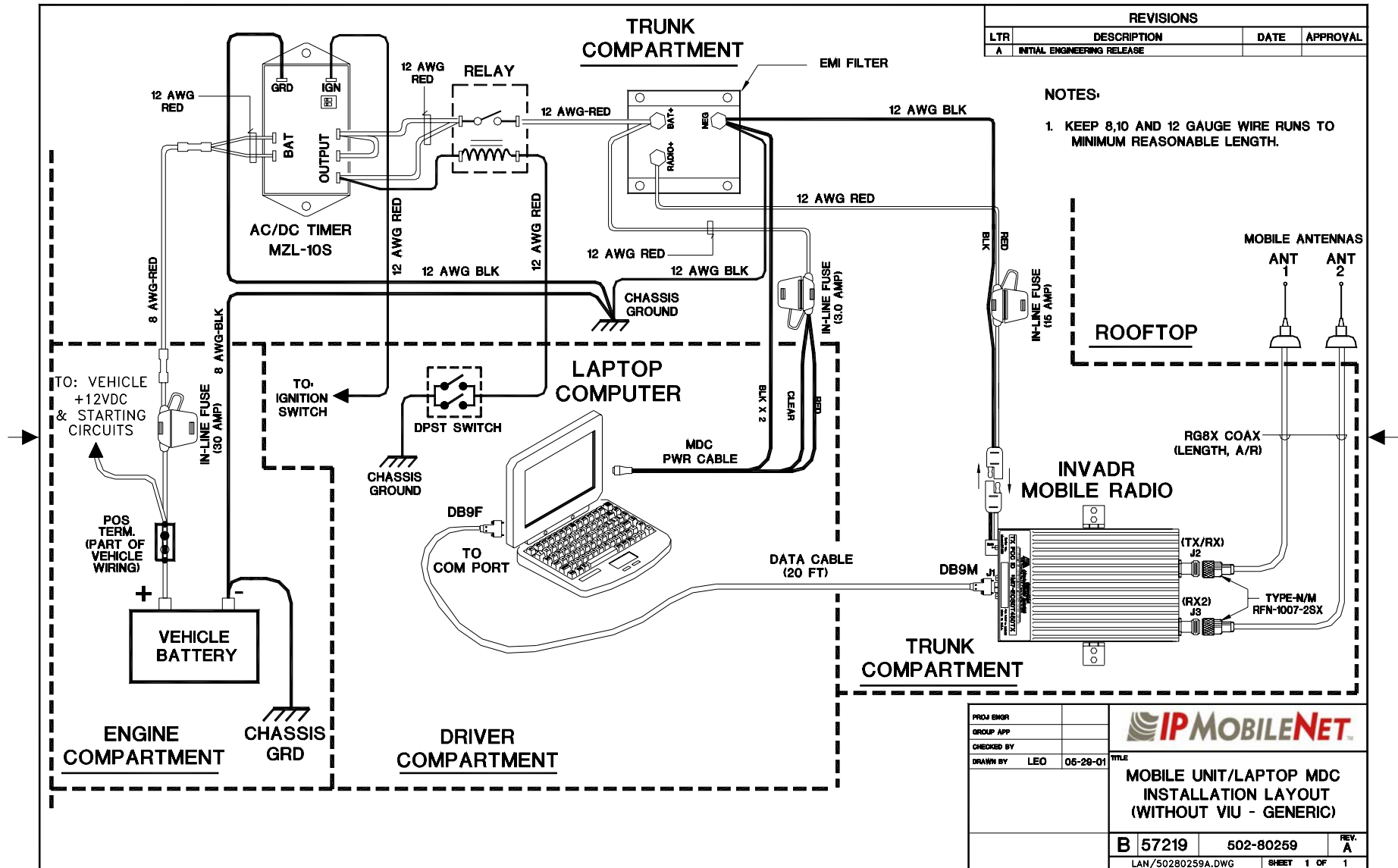

REVISIONS			
LTR	DESCRIPTION	DATE	APPROVAL
A	INITIAL ENGINEERING RELEASE		

**NOTES:**  
 1. KEEP 8,10 AND 12 GAUGE WIRE RUNS TO MINIMUM REASONABLE LENGTH.

PROJ ENGR GROUP APP CHECKED BY DRAWN BY LEO 06-29-01	
<b>TITLE</b> MOBILE UNIT/LAPTOP MDC INSTALLATION LAYOUT (WITHOUT VIU - GENERIC)	
<b>B</b> 57219	502-80259
LAN/50280259A.DWG	SHEET 1 OF 1

## MOBILE ANTENNA DISTANCE MATRIX

Frequency Band in MHz	Center Frequency in MHz	Antenna Spacing** @ ¼ Wavelength	Antenna Spacing** @ ¾ Wavelength	NFEZ* in inches for Radome Antenna	NFEZ* in inches for ¼ Wavelength Whip	NFEZ* in inches for “5/8” Wavelength Whip	Wavelength in Inches
130-140	135.000	21.87	N/A	0.25	10.94	N/A	87.49
140-150	145.000	20.36	N/A	0.27	10.18	N/A	81.46
150-160	155.000	19.05	N/A	0.29	9.53	N/A	76.20
160-174	162.000	18.23	N/A	0.30	9.11	N/A	72.91
400-430	415.000	N/A	21.35	0.77	3.56	11.88	28.46
430-450	440.000	N/A	20.13	0.81	3.36	10.37	26.84
450-470	460.000	N/A	19.26	0.85	3.21	9.43	25.68
470-490	480.000	N/A	18.45	0.89	3.08	9.31	24.61
490-512	501.000	N/A	17.68	0.92	2.95	9.35	23.57
806-866	836.000	N/A	10.60	1.54	1.77	3.36	14.13

\*NFEZ = Minimum Near Field Exclusion Zone

\*\*Round antenna spacing to the nearest 1/8”

## DIVERSITY ANTENNA MOBILE INSTALLATION DETAIL (Typical installation)

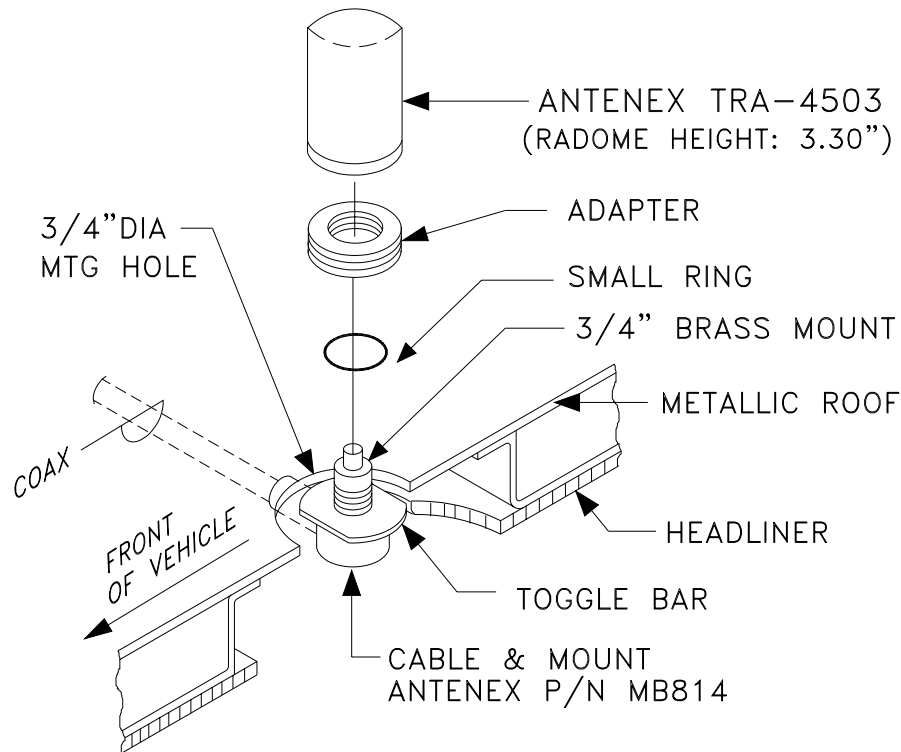

**DETAIL A**

**NOTES:**

1. THE MB8X14 BRASS MOUNT REQUIRES A 3/4" HOLE IN A METAL FLAT AREA WITH A THICKNESS BETWEEN .040" AND .075".
2. FEED THE COAXIAL CABLE THROUGH THE HOLE UNTIL THE ASSEMBLY IS IN A POSITION TO DROP IN THE HOLE.
3. BE SURE THAT THE SMALL RING IS IN THE LOCK-NUT GROOVE.
4. THEN THREAD THE ADAPTER ONTO THE BUSHING. THE ADAPTER SHOULD BE TIGHTENED UNTIL IT COMES IN CONTACT WITH THE ROOF METAL SURFACE AND THE SMALL RING IS COMPRESSED.
5. THEN THREAD THE ANTENNA ONTO THE ADAPTER. MAKE SURE IT IS HAND TIGHTENED.
6. ROUTE THE CABLE TO THE RADIO. CUT OFF ANY EXCESS CABLE.
7. ATTACH THE N-MALE, CRIMP CONNECTOR, CN58, TO THE CABLE.

CAD GENERATED FILE, DO NOT MANUALLY CHANGE REVISIONS			
DRAWN	LEO	DATE	06-06-01
CHECKED		TITLE	
DESIGN		<b>450MHz DIVERSITY ANTENNA MOBILE INSTALLATION (ANTENEX MODEL TRA-4503)</b>	
APPROVED	SCALE	CODE IDENT NO.	REV
RELEASED	NONE	57219	00
SCALE		40201-5A.DWG	SHEET 5 OF 8

# VEHICLE UNIT WIRING INTERCONNECTION LAYOUT (with Voice Interface Unit – VIU)

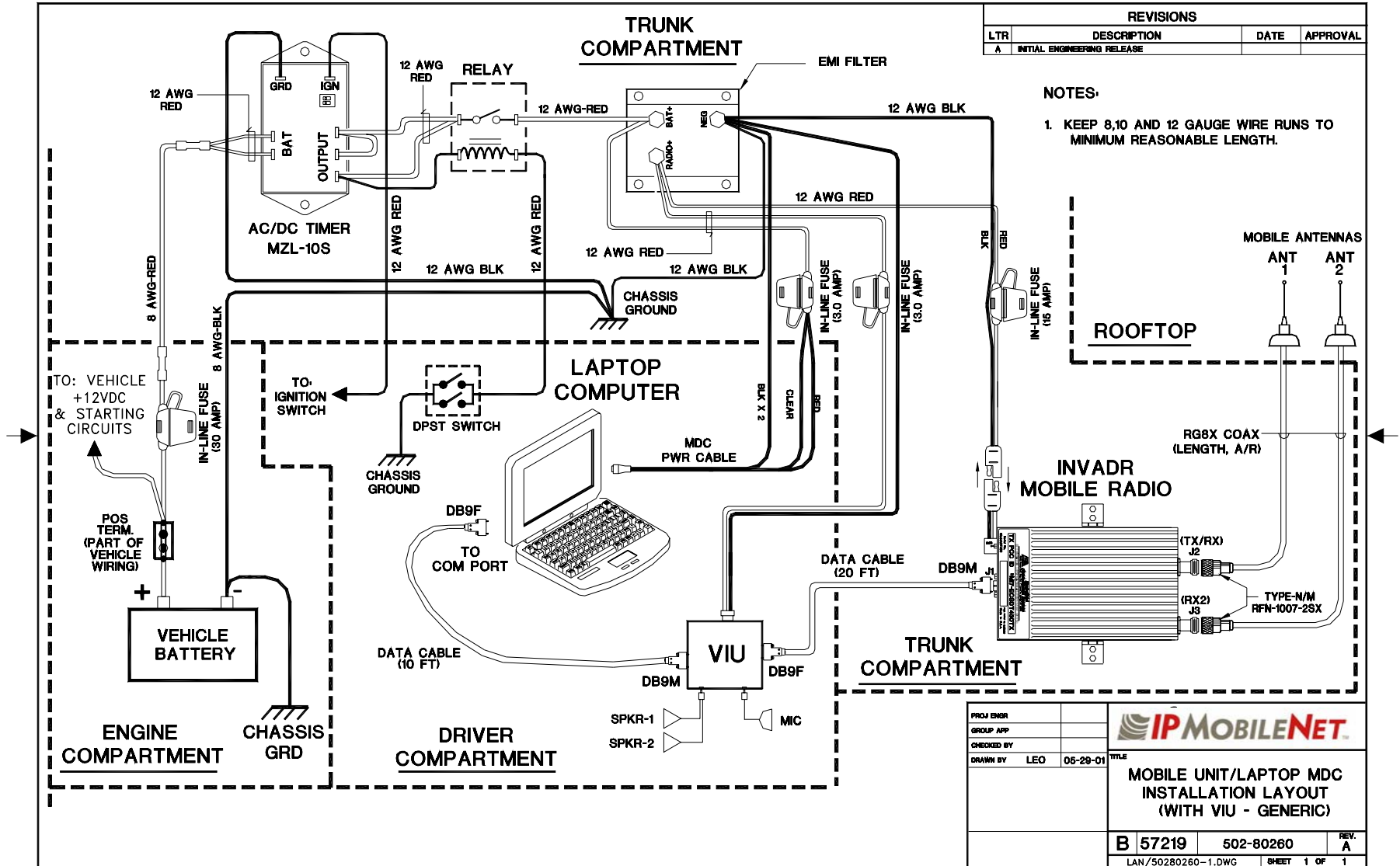

REVISIONS			
LTR	DESCRIPTION	DATE	APPROVAL
A	INITIAL ENGINEERING RELEASE		

**NOTES:**  
1. KEEP 8,10 AND 12 GAUGE WIRE RUNS TO MINIMUM REASONABLE LENGTH.

PROJ ENGR			TITLE <b>MOBILE UNIT/LAPTOP MDC INSTALLATION LAYOUT (WITH VIU - GENERIC)</b>	
GROUP APP				
CHECKED BY				
DRAWN BY	LEO 05-29-01	B 57219	502-80280	REV. A
		LAN/50280260-1.DWG		SHEET 1 OF 1

# VEHICLE UNIT WIRING INTERCONNECTION LAYOUT

## (Data 911 with Voice Interface Unit – VIU)

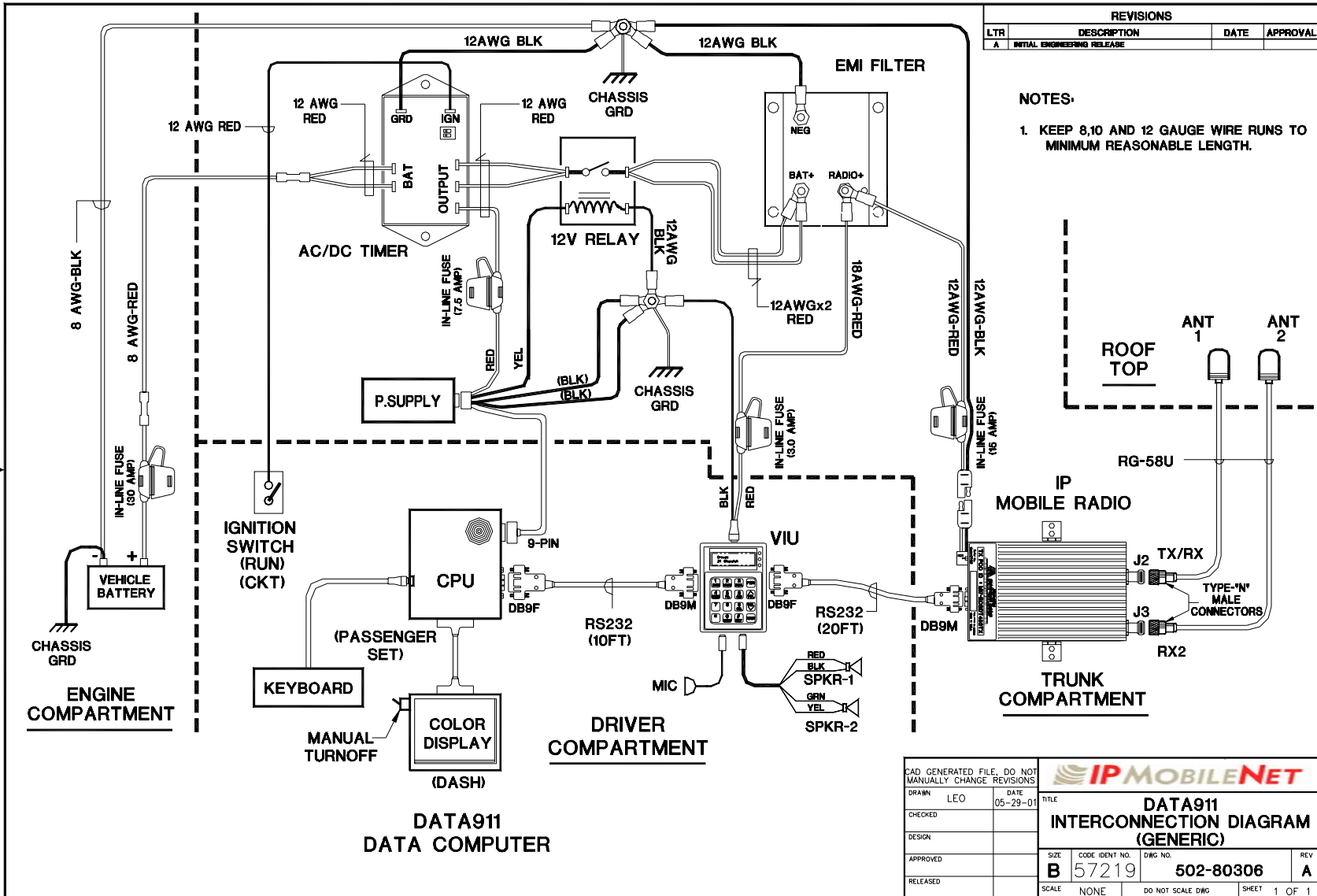

REVISIONS			
LTR	DESCRIPTION	DATE	APPROVAL
A	INITIAL ENGINEERING RELEASE		

**NOTES:**

- KEEP 8,10 AND 12 GAUGE WIRE RUNS TO MINIMUM REASONABLE LENGTH.

CAD GENERATED FILE. DO NOT MANUALLY CHANGE REVISIONS		<b>IPMOBILENET</b>	
DRAWN LEO	DATE 05-29-01	TITLE DATA911 INTERCONNECTION DIAGRAM (GENERIC)	
CHECKED		SIZE B	CODE IDENT NO. 57219
DESIGN		DWG NO. 502-80306	REV A
APPROVED		SCALE NONE	DO NOT SCALE DWG
RELEASED		SHEET 1 OF 1	

LAN/50280.306.DWG

# VEHICLE UNIT WIRING INTERCONNECTION LAYOUT (with Litton Computer)

