

WIFI-V897 Series

IEEE 802.11 2X2 MIMO ac/a/b/g/n WiFi

Features :

- **Reserving System**
 - IEEE Std. 802.11a
 - IEEE Std. 802.11b
 - IEEE Std. 802.11g
 - IEEE Std. 802.11n
 - IEEE Std. 802.11ac
- **Chip Solution**
 - Marvell 88W8897



Model	Standard	Rate	Channel	POWER
WIFI-2-V897EA1	IEEE 802.11a/b/g/n/ac	866.7Mbps	2.4G/5G	5V

Sichuan AI-Link Technology Co.,Ltd

Add: Anzhou,Industrial park,Mianyang,Sichuan,China

Fax : +86-0816-2416943

<http://www.changhong.com>

Feedback of customer's Confirmation

We accept the specification after Confirmed

Customer name	Customer signature	Confirmation Date

Please feed back this paper and first paper after your signature by the address,thanks!

ADD: Anzhou,Industrial park,Mianyang,Sichuan,China

Factory: Sichuan iLink Technology Co.,Ltd.

Approved	Checked	Designed	Product	WiFi Module
Bai lang	Qian zijin	Fan xijun	Model	WIFI-2-V897EA1
			Date	2018-05-18

Record of Modification

No	Date of modification	Main content of modification	Reason of modification	Serial number of modification	Confirm
1	20180518	Confirmed for the first time			Fan xijun

1. Introduction

WIFI-2-V897EA1 is based on Marvell 88W8897, complied with IEEE 802.11a/b/g/n/ac. The Module is a highly integrated MAC/BBP and 2.4/5GHz RF/PA/LNA single chip which supports a 866.7Mbps PHY rate. The Module is designed to support standard-based features in the areas of security, quality of service, and international regulations, giving end users the greatest performance anytime and in any circumstance. This documentation describes the engineering requirements specification.

- IEEE802.11ac (draft)compliant,2x2 MIMO spatial stream multiplexing with data rates up to MCS9(866.7Mbps)

1.1 RF module Overview

The general HW architecture for the module is shown in Figure 1. This WLAN Module design is based on Marvell 88W8897. It is a highly integrated single-chip MIMO(Multiple In Multiple Out) Wireless LAN (WLAN) network interface controller complying with the 802.11ac specification over SDIO,PCIE,USB and UART interface.. It combines a MAC, a 2T2R capable baseband, and RF in a single chip. The 88w8897 provides a complete solution for a high throughput performance wireless client .

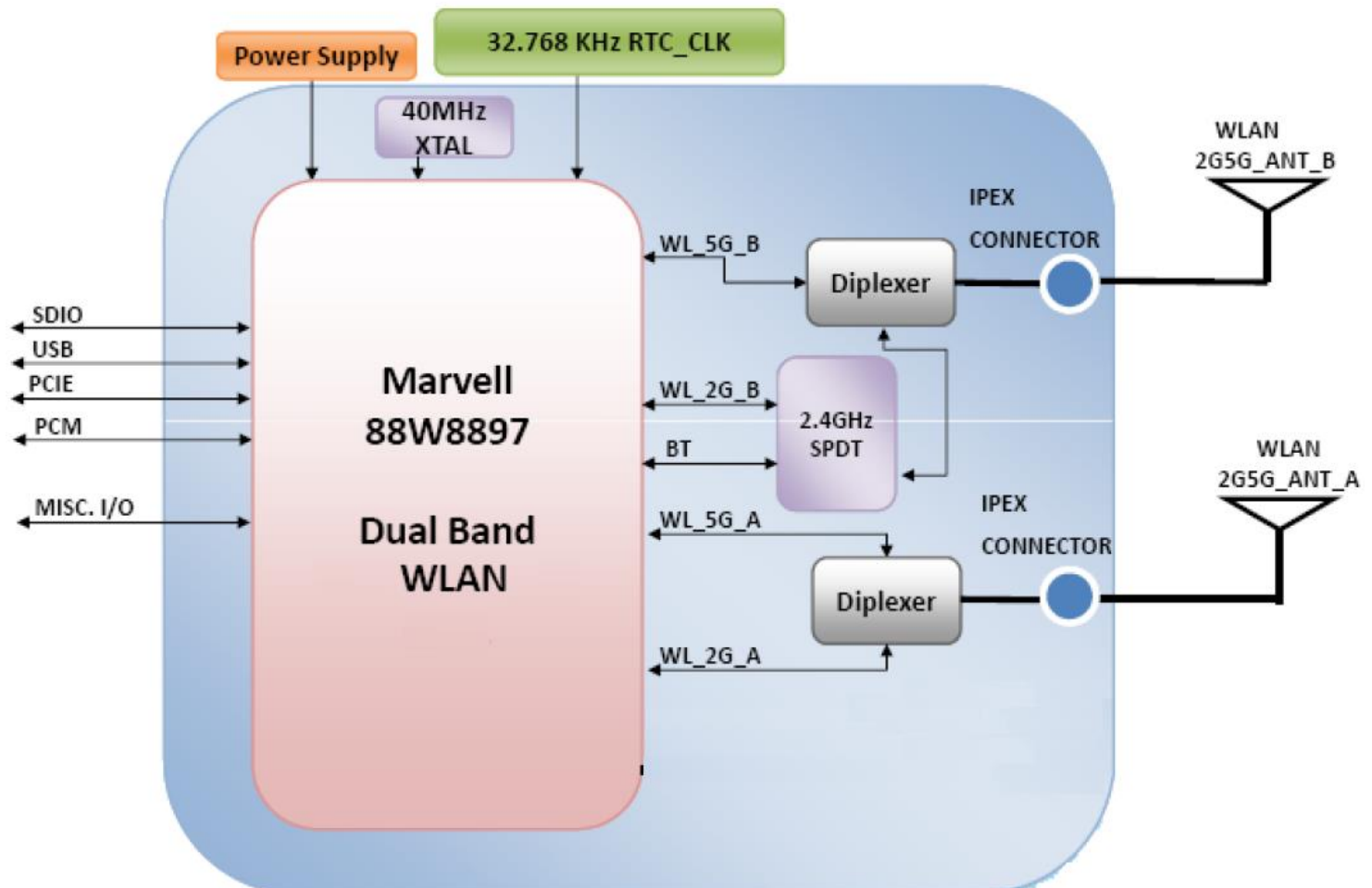

Figure 1 WIFI-2-V897EA1 Block Diagram

Note: Interface supports and combinations as shown below:

Scenario	WLAN	Firmware Download I/F	Firmware Download Mode	Configuration *
1	PCIe	PCIe	Serial	CON[3:0]=b'1110

NOTE:

PCIe v3.0(2.5Gbps) interface

USB 2.0 interface with LPM support

1.2 Specification reference

This specification is based on additional references listed below.

- _ **IEEE Std. 802.11a**
- _ **IEEE Std. 802.11b**
- _ **IEEE Std. 802.11g**
- _ **IEEE Std. 802.11n**
- _ **IEEE Std. 802.11ac**

1.3 System Functions

Table 1: General Specification as below:

Main Chip set	Marvell 88W8897
Operating Frequency	2.4G/5G
WiFi Standard	802.11a/b/g/n/ac(2x2)
Modulation	11b: DBPSK, DQPSK and CCK and DSSS 11a/g: BPSK, QPSK, 16QAM, 64QAM and OFDM 11n: BPSK, QPSK, 16QAM, 64QAM and OFDM 11ac: BPSK, QPSK, 16QAM, 64QAM, 256QAM and OFDM
Data rates	11b: 1, 2, 5.5 and 11Mbps 11a/g: 6, 9, 12, 18, 24, 36, 48 and 54 Mbps 11n: MCS0~15, up to 300Mbps 11ac: MCS0~9, Nss=2, up to 866.7Mbps
Form factor	LGA
Host Interface	PCIe, USB
PCB Stack	6-layers design
Dimension	Typical, 30.0mmx 26.8mm
Antenna	External antenna
Operation Temperature	-20 °C to +50 °C
Storage Temperature	-20 °C to +50 °C
Operation Voltage	DC 3.3V ,
Interfaces	PCIe interfaces support for WLAN
Systems	<ol style="list-style-type: none"> 1、 Drip-in WLAN Linux drivers are Android ready and validated on Android based systems. 2、 Support for Linux kernel versions up to 2.6.32.

2. Mechanical Specification

Typical Dimension (L x W): 30.0mmx 26.8mm

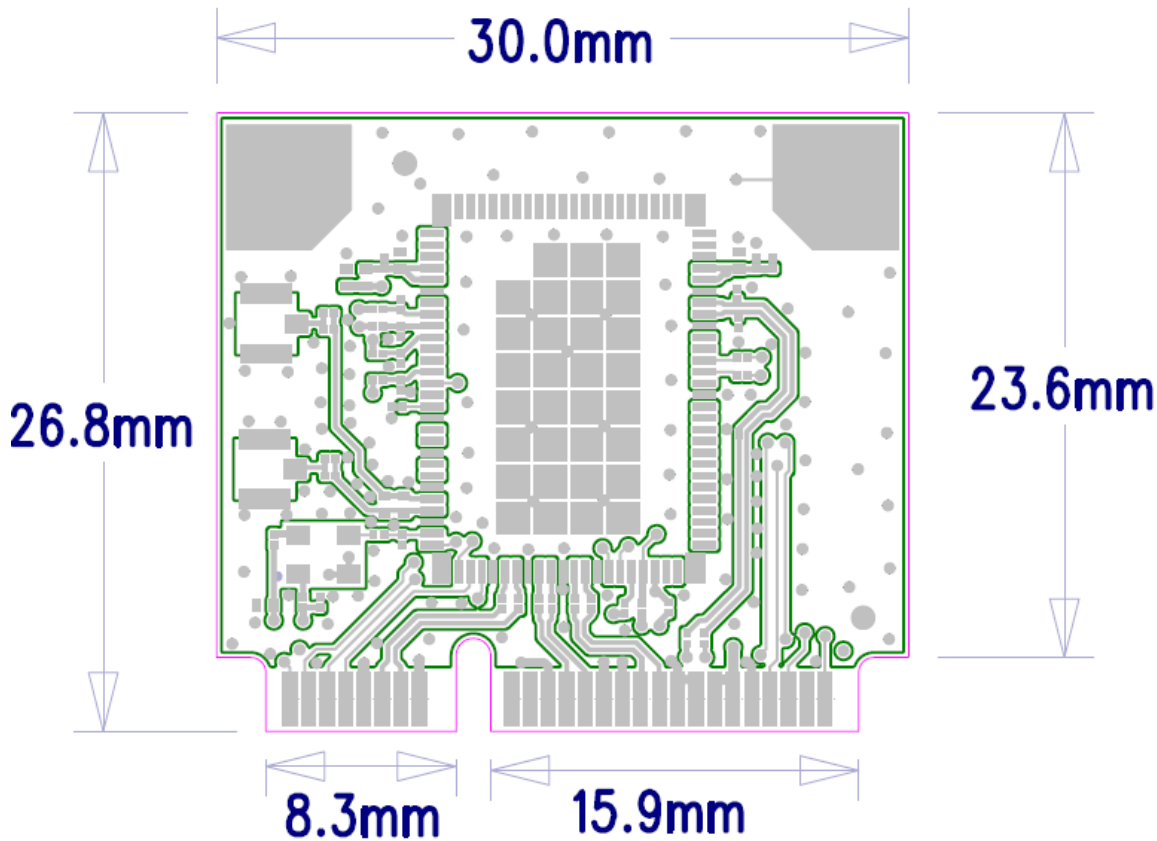

Pin feet from left to right

PIN	Description	PIN	Description	PIN	Description
1	WAKEn	19	N.C	37	GND
2	VDD33	20	PCIE_DISABLE	38	USB_DP
3	GPIO0/CLK_REQ	21	GND	39	VDD3.3V
4	GND	22	PCIE_PERST	40	GND
5	WLAN_IRQ(O)/WAKE_UP	23	PCIE_TX_N	41	VDD3.3V
6	N.C	24	VDD3.3V	42	N.C
7	PCIE_CLKREQ_N	25	PCIE_TX_P	43	GND
8	N.C	26	GND	44	LED_WLAN
9	GND	27	GND	45	GPIO[10]/NFC_NOT_ALLOWED
10	N.C	28	N.C	46	LED_WPAN
11	PCIE_CLE_N	29	GND	47	GPIO[11]/NFC_ACTIVE
12	N.C	30	N.C	48	N.C
13	PCIE_CLK_P	31	PCIE_RX_N	49	N.C
14	N.C	32	N.C	50	GND
15	GND	33	PCIE_RX_P	51	PDN
16	N.C	34	GND	52	+3.3Vaux
17	N.C	35	GND		
18	GND	36	USB_DM		

Notes:

1. PCIE Impedance targets: Single-ended Z of 60 ohms +- 15% . Differential Impedance of ~100 ohm +- 20%.

2. USB Impedance targets: D+/D- are differential and should have 90ohms impedance.

3. Product Picture



TOP VIEW



BOTTOM VIEW

4. Electrical Specification

This Specification is based-on conductive DVT testing result. The extreme condition include overall temperature (-20°C,+25°C,+50°C) and overall voltage (3.3V +/-15% ,).

4. 1 Absolute Maximum Ratings:

Symbol	Parameter	Min.	Typ.	Max.	Unit	Remarks
Pin73/ VIO	Host I/O power supply	-	1.8	2.2	V	
		-	2.5	3.0		
		-	3.3	4.0		
Pin44/ VIO_SD	SDIO power supply	-	1.8	2.2	V	
		-	3.3	4.0		
Pin5/ 3V3_VBAT	LDO VBAT input	-	3.3	4.0	V	
Pin72/ 3V3_USB	LDO USB VBAT input	-	3.3	4.0	V	
Pin4/ 3V3_RF	LDO RF VBAT input	-	3.3	4.0	V	

4. 2 Recommended Operating Conditions:

Symbol	Parameter	Min.	Typ.	Max.	Unit	Remarks
Pin73/ VIO	1.8V/2.5V/3.3V digital I/O power supply	1.62	1.8	1.98	V	
		2.25	2.5	2.75		
		2.97	3.3	3.63		
Pin44/ VIO_SD	1.8V/3.3V digital I/O SDIO power supply	1.62	1.8	1.98	V	
		2.97	3.3	3.63		
Pin5/ 3V3_VBAT	LDO VBAT input	2.7	3.3	5.0	V	
Pin72/ 3V3_USB	LDO USB VBAT input	2.97	3.3	3.63	V	
Pin4/ 3V3_RF	LDO RF VBAT input	2.97	3.3	3.63	V	

4. 3 IEEE 802.11a Section:

Items	Contents				
Specification	IEEE802.11a				
Mode	BPSK, QPSK, 16QAM, 64QAM and OFDM				
Channel	CH36 to CH165				
Data rate	6, 9, 12, 18, 24, 36, 48, 54Mbps				
TX Characteristics	Min.	Typ.	Max.	Unit	Remark
1. Power Levels					
1) 13dBm Target (For Each antenna port)	12	-	14	dBm	
2. Spectrum Mask @ Target Power					
1) at fc +/-11MHz	-	-	-20	dBr	
2) at fc +/-20MHz	-	-	-28	dBr	
3) at fc > +/-30MHz	-	-	-40	dBr	
3. Constellation Error(EVM) @ Target Power					
1) 6Mbps	-	-	-5	dB	
2) 9Mbps	-	-	-8	dB	
3) 12Mbps	-	-	-10	dB	
4) 18Mbps	-	-	-13	dB	
5) 24Mbps	-	-	-16	dB	
6) 36Mbps	-	-	-19	dB	
7) 48Mbps	-	-	-22	dB	
8) 54Mbps	-	-	-25	dB	
4. Frequency Error	-20		20	ppm	
RX Characteristics	Min.	Typ.	Max.	Unit	
5. Minimum Input Level Sensitivity(each chain)					
1) 6Mbps (PER \leq 10%)	-	-	-84	dBm	
2) 9Mbps (PER \leq 10%)	-	-	-83	dBm	
3) 12Mbps (PER \leq 10%)	-	-	-81	dBm	
4) 18Mbps (PER \leq 10%)	-	-	-79	dBm	
5) 24Mbps (PER \leq 10%)	-	-	-76	dBm	
6) 36Mbps (PER \leq 10%)	-	-	-72	dBm	
7) 48Mbps (PER \leq 10%)	-	-	-68	dBm	
8) 54Mbps (PER \leq 10%)	-	-	-67	dBm	
6. Maximum Input Level (PER \leq 10%)	-30			dBm	

4.4 IEEE 802.11b Section:

Items	Contents				
Specification	IEEE802.11b				
Mode	DBPSK, DQPSK and CCK and DSSS				
Channel	CH1 to CH13				
Data rate	1, 2, 5.5, 11Mbps				
TX Characteristics	Min.	Typ.	Max.	Unit	Remark
1. Power Levels(Calibrated)					
1) 13dBm Target (For Each antenna port)	11	-	14	dBm	
2. Spectrum Mask @ Target Power					
1) fc +/-11MHz to +/-22MHz	-	-	-30	dBr	
2) fc > +/-22MHz	-	-	-50	dBr	
3. Constellation Error(EVM) @ Target Power					
1) 1Mbps	-	-	-10	dB	
2) 2Mbps	-	-	-10	dB	
3) 5.5Mbps	-	-	-10	dB	
4) 11Mbps	-	-20	-10	dB	
4. Frequency Error	-20	-	20	ppm	
RX Characteristics	Min.	Typ.	Max.	Unit	
5. Minimum Input Level Sensitivity(each chain)					
1) 1Mbps (FER \leq 8%)	-	-	-83	dBm	
2) 2Mbps (FER \leq 8%)	-	-	-83	dBm	
3) 5.5Mbps (FER \leq 8%)	-	-	-83	dBm	
4) 11Mbps (FER \leq 8%)	-	-	-83	dBm	
6. Maximum Input Level (FER \leq 8%)	-10	-	-	dBm	

4.5 IEEE 802.11g Section:

Items	Contents				
Specification	IEEE802.11g				
Mode	BPSK, QPSK, 16QAM, 64QAM and OFDM				
Channel	CH1 to CH13				
Data rate	6, 9, 12, 18, 24, 36, 48, 54Mbps				
TX Characteristics	Min.	Typ.	Max.	Unit	Remark
1. Power Levels					
1) 13dBm Target (For Each antenna port)	10	-	14	dBm	
2. Spectrum Mask @ Target Power					
1) at fc +/-11MHz	-	-	-20	dBr	
2) at fc +/-20MHz	-	-	-28	dBr	
3) at fc > +/-30MHz	-	-	-40	dBr	
3. Constellation Error(EVM) @ Target Power					
1) 6Mbps	-	-	-5	dB	
2) 9Mbps	-	-	-8	dB	
3) 12Mbps	-	-	-10	dB	
4) 18Mbps	-	-	-13	dB	
5) 24Mbps	-	-	-16	dB	
6) 36Mbps	-	-	-19	dB	
7) 48Mbps	-	-	-22	dB	
8) 54Mbps	-	-	-25	dB	
4. Frequency Error	-10	-	10	ppm	
RX Characteristics	Min.	Typ.	Max.	Unit	
5. Minimum Input Level Sensitivity(each chain)					
1) 6Mbps (PER \leq 10%)	-	-	-89	dBm	
2) 9Mbps (PER \leq 10%)	-	-	-87	dBm	
3) 12Mbps (PER \leq 10%)	-	-	-86	dBm	
4) 18Mbps (PER \leq 10%)	-	-	-84	dBm	
5) 24Mbps (PER \leq 10%)	-	-	-81	dBm	
6) 36Mbps (PER \leq 10%)	-	-	-77	dBm	
7) 48Mbps (PER \leq 10%)	-	-	-73	dBm	
8) 54Mbps (PER \leq 10%)	-	-	-72	dBm	
6. Maximum Input Level (PER \leq 10%)	-30			dBm	

4.6 IEEE 802.11n HT20 Section:

Items	Contents				
Specification	IEEE802.11n HT20 @ 2.4G IEEE802.11n HT20 @ 5G				
Mode	BPSK, QPSK, 16QAM, 64QAM and OFDM				
Channel	CH1 to CH13 @ 2.4G CH36 to CH165 @ 5G				
Data rate (MCS index)	MCS0/1/2/3/4/5/6/7/8/9/10/11/12/13/14/15				
TX Characteristics	Min.	Typ.	Max.	Unit	Remark
1. Power Levels					
1) 13dBm Target (For Each antenna port) @ 2.4G	10	-	14	dBm	
2) 13dBm Target (For Each antenna port) @ 5G	10	-	14	dBm	
2. Spectrum Mask @ Target Power					
1) at fc +/-11MHz	-	-	-20	dBr	
2) at fc +/-20MHz	-	-	-28	dBr	
3) at fc > +/-30MHz	-	-	-45	dBr	
3. Constellation Error(EVM) @ Target Power					
1) MCS0	-	-	-5	dB	
2) MCS1	-	-	-10	dB	
3) MCS2	-	-	-13	dB	
4) MCS3	-	-	-16	dB	
5) MCS4	-	-	-19	dB	
6) MCS5	-	-	-22	dB	
7) MCS6	-	-	-25	dB	
8) MCS7	-	-	-28	dB	
4. Frequency Error					
1) IEEE802.11n HT20 @ 2.4G	-10	-	10	ppm	
2) IEEE802.11n HT20 @ 5G	-10	-	10	ppm	
RX Characteristics	Min.	Typ.	Max.	Unit	
5. Minimum Input Level Sensitivity(each chain)					
1) MCS0 (PER \leq 10%)	-	-	-85	dBm	
2) MCS1 (PER \leq 10%)	-	-	-82	dBm	
3) MCS2 (PER \leq 10%)	-	-	-80	dBm	
4) MCS3 (PER \leq 10%)	-	-	-77	dBm	
5) MCS4 (PER \leq 10%)	-	-	-73	dBm	
6) MCS5 (PER \leq 10%)	-	-	-69	dBm	
7) MCS6 (PER \leq 10%)	-	-	-68	dBm	
8) MCS7 (PER \leq 10%)	-	-	-67	dBm	
6. Maximum Input Level (PER \leq 10%)					
1) IEEE802.11n HT20 @ 2.4G	-20	-	-	dBm	
2) IEEE802.11n HT20 @ 5G	-30	-	-	dBm	

4.7 IEEE 802.11n HT40 Section:

Items	Contents				
Specification	IEEE802.11n HT40 @ 2.4G IEEE802.11n HT40 @ 5G				
Mode	BPSK, QPSK, 16QAM, 64QAM and OFDM				
Channel	CH3 to CH11 @ 2.4G CH38 to CH163 @ 5G				
Data rate (MCS index)	MCS0/1/2/3/4/5/6/7/8/9/10/11/12/13/14/15				
TX Characteristics	Min.	Typ.	Max.	Unit	Remark
1. Power Levels (Calibrated)					
1) 12dBm Target (For Each antenna port) @ 2.4G	10	-	13	dBm	
2) 12dBm Target (For Each antenna port) @ 5G	10	-	13	dBm	
2. Spectrum Mask @ Target Power					
1) at fc +/-21MHz	-	-	-20	dBr	
2) at fc +/-40MHz	-	-	-28	dBr	
3) at fc > +/-60MHz	-	-	-45	dBr	
3. Constellation Error(EVM) @ Target Power					
1) MCS0	-	-	-5	dB	
2) MCS1	-	-	-10	dB	
3) MCS2	-	-	-13	dB	
4) MCS3	-	-	-16	dB	
5) MCS4	-	-	-19	dB	
6) MCS5	-	-	-22	dB	
7) MCS6	-	-	-25	dB	
8) MCS7	-	-	-28	dB	
4. Frequency Error					
1) IEEE802.11n HT20 @ 2.4G	-10	-	10	ppm	
2) IEEE802.11n HT20 @ 5G	-12	-	12	ppm	
RX Characteristics	Min.	Typ.	Max.	Unit	
5. Minimum Input Level Sensitivity(each chain)					
1) MCS0 (PER \leq 10%)	-	-	-82	dBm	
2) MCS1 (PER \leq 10%)	-	-	-79	dBm	
3) MCS2 (PER \leq 10%)	-	-	-77	dBm	
4) MCS3 (PER \leq 10%)	-	-	-74	dBm	
5) MCS4 (PER \leq 10%)	-	-	-70	dBm	
6) MCS5 (PER \leq 10%)	-	-	-66	dBm	
7) MCS6 (PER \leq 10%)	-	-	-65	dBm	
8) MCS7 (PER \leq 10%)	-	-	-64	dBm	
6. Maximum Input Level(PER \leq 10%)					
1) IEEE802.11n HT20 @ 2.4G	-20	-	-	dBm	
2) IEEE802.11n HT20 @ 5G	-30	-	-	dBm	

4.8 IEEE 802.11ac20/ac40 Section:

Items	Contents				
Specification	IEEE802.11ac20/ac40				
Mode	BPSK, QPSK, 16QAM, 64QAM ,256QAM and OFDM				
Channel	CH42 to CH157				
Data rate (MCS index)	MCS0/1/2/3/4/5/6/7/8/9				
TX Characteristics	Min.	Typ.	Max.	Unit	Remark
1. Power Levels (Calibrated)					
1) 12dBm Target (For Each antenna port)	10	-	13	dBm	
2. Spectrum Mask @ Target Power	10	-	13		
1) at fc +/-11MHz /20MHz/30MHz	-	-	-20	dBr	
2) at fc +/-21MHz /40MHz/60MHz	-	-	-28	dBr	
3) at fc +/-41MHz /80MHz/120MHz	-	-	-40	dBr	
3. Constellation Error(EVM) @ Target Power					
1) MCS0	-	-	-5	dB	
2) MCS1	-	-	-10	dB	
3) MCS2	-	-	-13	dB	
4) MCS3	-	-	-16	dB	
5) MCS4	-	-	-19	dB	
6) MCS5	-	-	-22	dB	
7) MCS6	-	-	-25	dB	
8) MCS7	-	-	-27	dB	
9) MCS8			-30	dB	
10) MCS9			-32	dB	
4. Frequency Error	-10	-	10	ppm	
RX Characteristics	Min.	Typ.	Max.	Unit	
5. Minimum Input Level Sensitivity(each chain)			VHT80		
1) MCS0 (PER \leq 10%)			-76	dBm	
2) MCS1 (PER \leq 10%)			-73	dBm	
3) MCS2 (PER \leq 10%)			-71	dBm	
4) MCS3 (PER \leq 10%)			-68	dBm	
5) MCS4 (PER \leq 10%)			-65	dBm	
6) MCS5 (PER \leq 10%)			-63	dBm	
7) MCS6 (PER \leq 10%)			-61	dBm	
8) MCS7 (PER \leq 10%)			-59	dBm	
9) MCS8 (PER \leq 10%)			-56	dBm	
10) MCS9 (PER \leq 10%)			-54	dBm	
6. Maximum Input Level(PER \leq 10%)	-30	-	-	dBm	

4.9 Clock Specifications

Symbol	Parameter	Min.	Typ.	Max.	Unit
CLK	Clock Frequency Range	32 or 32.768 -50ppm	32 or 32.768	32 or 32.768 +50ppm	KHz
T _{HIGH}	Clock high time	40	-	-	ns
T _{LOW}	Clock low time	40	-	-	ns
T _{RISE}	Clock rise time	-	-	5	ns
T _{FALL}	Clock fall time	-	-	5	ns

4.10 Reset Configuration

WIFI-2-V897EA1 is reset to its default operating state under the following conditions:

- Power-on reset (POR)
- Software/Firmware reset
- External pin reset (RESETn)

4.11 Power up Timing Sequence

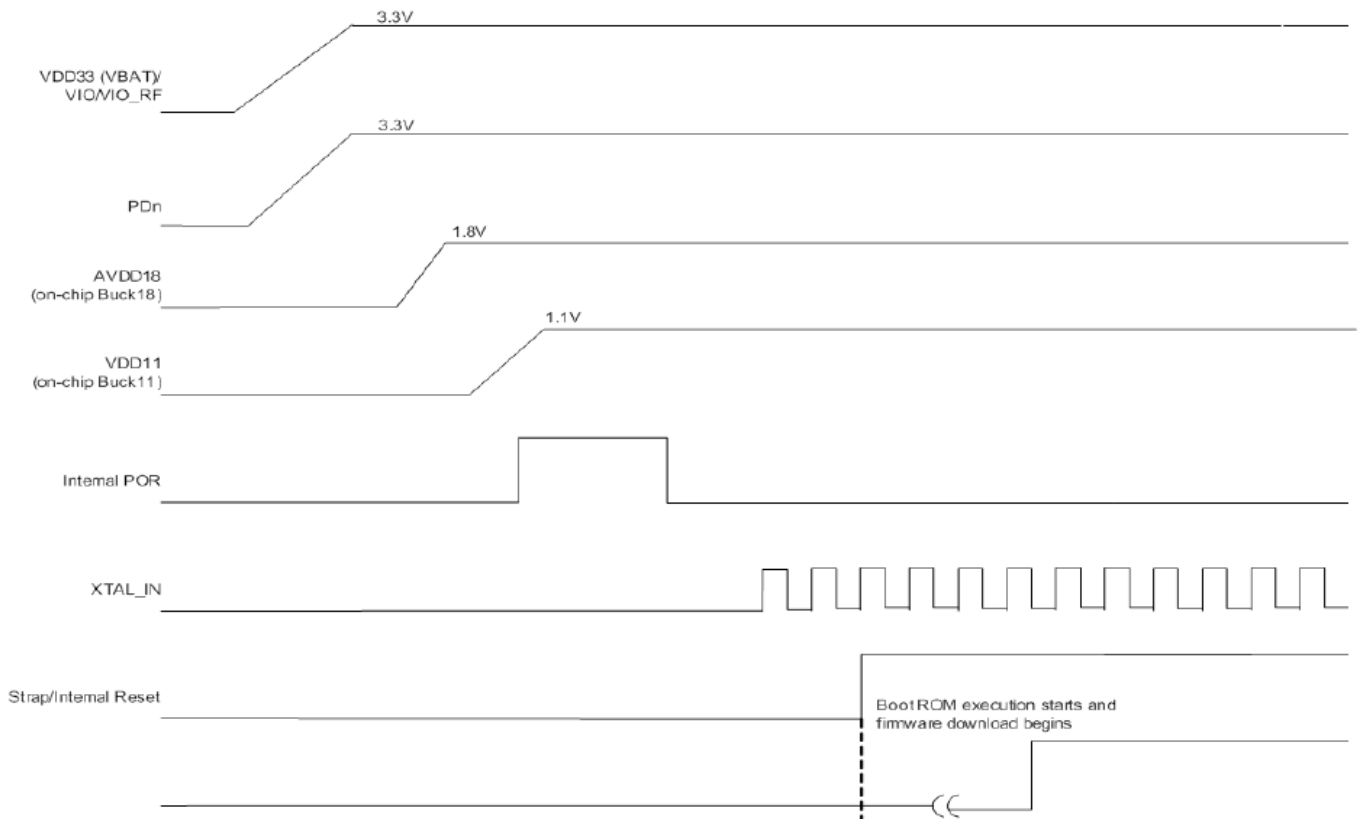

5. Interfaces

5.1.1 Host Interface

Pin Name	Supply	No Pad Power State	Reset State	HW State ¹	PD ² State	PD Prog ³	Internal PU/PD	PU ⁴	PD ³
PCIE_RCLK_P	AVDD18	--	--	--	--	--	--	--	--
PCI Express Differential Clock Input—Positive									
PCIE_RCLK_N	AVDD18	--	--	--	--	--	--	--	--
PCI Express Differential Clock Input—Negative									
PCIE_TX_P	AVDD18	--	--	--	--	--	--	--	--
PCI Express Transmit Data—Positive									
PCIE_TX_N	AVDD18	--	--	--	--	--	--	--	--
PCI Express Transmit Data—Negative									
PCIE_RX_P	AVDD18	--	--	--	--	--	--	--	--
PCI Express Receive Data—Positive									
PCIE_RX_N	AVDD18	--	--	--	--	--	--	--	--
PCI Express Receive Data—Negative									
PCIE_WAKEn	VIO	tristate	input	output	n/a	n/a	n/a	no	no
PCIe wake signal (output) (active low)									
PCIE_CLKREQn	VIO	tristate	input	output	n/a	n/a	n/a	no	no
PCIe clock request (input/output) (active low)									
PCIE_W_DISABLE/ GPIO[13]	VIO	tristate	input	input	tristate	yes	nominal PU	yes	yes
PCIe Mode: PCIe host indication to disable the WLAN function of the device (input) (active low) GPIO Mode: GPIO[13]									
PCIE_PERSTn/ GPIO[12]	VIO	tristate	input	input	tristate	yes	nominal PD	yes	yes
PCIe Mode: PCIe host indication to reset the device (input) (active low) GPIO Mode: GPIO[12]									

5.1.2 PCI Express Interface

Pin Name	PCI Express Specification Pin Name	I/O	Description
PCIE_RCLK_N	REFCLK_N	I	PCI Express Platform Reference Clock Negative signal of differential pair 100 MHz low-voltage interface
PCIE_RCLK_P	REFCLK_P	I	PCI Express Platform Reference Clock Positive signal of differential pair 100 MHz low-voltage interface
PCIE_TX_N	TXN	O	PCI Express Lane 0, Transmit Pair, Negative Signal 2.5 GHz serial low-voltage interface
PCIE_TX_P	TXP	O	PCI Express Lane 0, Transmit Pair, Positive Signal 2.5 GHz serial low-voltage interface
PCIE_RX_N	RXN	I	PCI Express Lane 0, Receive Pair, Negative Signal 2.5 GHz serial low-voltage interface
PCIE_RX_P	RXP	I	PCI Express Lane 0, Receive Pair, Positive Signal 2.5 GHz serial low-voltage interface
PCIE_WAKEn	WAKE#	O	PCI Express Wake Signal Driven low to re-activate the PCI Express link hierarchy's main power rails and reference clocks (open drain, active low)
PCIE_CLKREQn	CLKREQ#	I/O	PCI Express Clock Request Driven low to request the availability of the PCI Express reference clock in order to allow the PCI Express interface to send/receive data (open drain, active low). If L1 Substate is enabled, it is also used as input to replace analog squelch detection and indicate request from link partner to recover the link.
PCIE_PRESTn	PERSTn#	I	PCI Express Reset Used for setting or returning all port states to the initial conditions specified in the PCIe base specification. Asserted 100 ms after power rails are within specifications. (active low)
PCIE_W_DISABLEn	W_DISABLE#	I	PCI Express Wireless Disable Allows users to disable, thru a system-provided switch, the add-in card's radio operation in order to meet public safety regulations or when otherwise desired (active low)

5.2 PCI Express Interface

5.2.1 Interface Signal Description

Symbol	Parameter	Min.	Typ.	Max.	Unit
UI	Unit interval Each UI 400 ps ± 300 PPM UI does not account for SSC dictated variations	399.98	400-	400.12	ps
V _{TX-DIFFpp}	Differential peak-to-peak output voltage $V_{TX_DIFFpp}=2* V_{TX_D+} - V_{TX_D-} $	0.8	-	1.2	V
V _{TX-DE-RATIO}	De-emphasized differential output voltage(radio)	-3.0	-3.5	-4.0	dB
T _{RX-EYE}	Minimum Tx eye width	0.75	-	-	UI
T _{RX-EYE-MEDIAN-MAX-JIT}	Maximum time between jitter median and maximum deviation from median	-	-	0.125	UI
T _{TX-RISE} T _{TX-FALL}	D+/D- Tx output rise/fall time	0.125	-	-	UI
T _{TX-CM-DC-ACTIVE-IDLE-DELTA}	Absolute delta of DC common mode voltage during L0 and electrical idle	0	-	100	mV
T _{TX-CM-DC-LINE-DE-LTA}	Absolute delta of DC common mode voltage between D+ and D-	0	-	25	mV
T _{TX-IDLE-DIFFp}	Electrical idle differential peak output voltage	0	-	20	mV
T _{TX-RCV-DETECT}	Voltage change allowed during receiver detection	-	-	600	mV
T _{TX-DC-CM}	Tx DC common mode voltage	-	-	3.6	V
T _{TX-SHORT}	Tx short circuit current limit	-	-	90	mA
T _{TX-IDLE-MIN}	Minimum time spent in electrical idle	50	-	-	UI
T _{TX-IDLE-SET-TO-IDLE}	Maximum time to transition to a valid electrical idle after sending an electrical idle ordered set	-	-	20	UI
T _{TX-IDLE-TO-DIFF-DTA}	Maximum time to transition to valid Tx specifications after leaving an electrical condition	-	-	20	UI
RL _{TX-DIFF}	Differential return loss	10	-	-	dB
RL _{TX-CM}	Common mode return loss	6	-	-	dB
C _{TX}	AC coupling capacitor	7.5	-	200	nF
T _{Crosstalk}	Crosstalk random timeout	0	-	1	ms

5.2.2 Differential Rx Output Electricals

Symbol	Parameter	Min.	Typ.	Max.	Unit
UI	Unit interval Each UI 400 ps ± 300 PPM UI does not account for SSC dictated variations	399.98	400-	400.12	ps
V _{RX-DIFFpp}	Differential peak-to-peak output voltage $V_{RX_DIFFpp}=2* V_{TX_D+} - V_{TX_D-} $	0.175	-	1.2	V
T _{RX-EYE}	Minimum Tx eye width	0.4	-	-	UI
T _{RX-EYE-MEDIAN- MAX-JIT}	Maximum time between jitter median and maximum deviation from median	-	-	0.3	UI
V _{RX-CM-ACp}	AC peak common mode input voltage	-	-	150	mV
RL _{RX-DIFF}	Differential return loss	10	-	-	dB
RL _{RX-CM}	Common mode return loss	6	-	-	dB
Z _{RX-DIFF-DC}	DC differential input impedance	80	100	120	Ω
Z _{RX-DC}	DC input impedance	40	50	60	Ω
Z _{RX-HIGH-IMP-DC-P OS}	Powered down DC input impedance positive	50	-	-	k
Z _{RX-HIGH-IMP-DC-N EG}	Powered down DC input impedance negative	1	-	-	kΩ
V _{RX-IDLE-DET-DIFF PP}	Electrical idle detect threshold	65	-	175	UI
T _{RX-IDLE-DET-DIFF- ENTERTIME}	Unexpected electrical idle enter detect threshold integration time	-	-	10	UI
L _{RX-SKEW}	Total skew	-	-2	0	dB

5.3 USB Interface

5.3.1 USB 2.0 Device Interface Description

Pin Name	USB 2.0 Specification Pin Name	Description
Pin72/3V3_USB	VBUS	USB Bus Power Supply On-board regulator regulates voltage from VBUS level to voltage levels used by USB PHY
	GND	USB Bus Ground Common ground on SoC device
Pin70/USB_DP	D+	USB Data Plus One of the differential data pair
Pin69/USB_DM	D-	USB Data Minus One of the differential data pair

Software Requirements

The driver supports the following operating systems: Linux, Microsoft Windows XP, Vista and Win7.

Mfg. software tool version is :

MFG-W8897-MF-WIFI-BT-NFC-NO-CAL-BRG-FC-WIN-X86-2.1.0.76-15.2.7.p22

7. Statement:

FCC Radiation Exposure Statement

Changes or modifications not expressly approved by the party responsible for compliance could void the user's authority to operate the equipment.

This equipment has been tested and found to comply with the limits for a Class B digital device, pursuant to Part 15 of the FCC Rules. These limits are designed to provide reasonable protection against harmful interference in a residential installation. This equipment generates uses and can radiate radio frequency energy and, if not installed and used in accordance with the

instructions, may cause harmful interference to radio communications. However, there is no guarantee that interference will not occur in a particular installation.

If this equipment does cause harmful interference to radio or television reception, which can be determined by turning the equipment off and on, the user is encouraged to try to correct the interference by one or more of the following measures:

- Reorient or relocate the receiving antenna.
- Increase the separation between the equipment and receiver.
- Connect the equipment into an outlet on a circuit different from that to which the receiver is connected.
- Consult the dealer or an experienced radio/TV technician for help

This device complies with part 15 of the FCC rules. Operation is subject to the following two conditions (1) this device may not cause harmful interference, and (2) this device must accept any interference received, including interference that may cause undesired operation.

FCC Radiation Exposure Statement

The modular can be installed or integrated in mobile or fix devices only. This modular be installed in any portable device, for example, USB dongle like transmitters is forbidden. This modular complies with FCC RF radiation exposure limits set forth for an uncontrolled environment. This transmitter must not be collocated or operating in conjunction with antenna or transmitter. If the FCC identification number is not visible when the module is installed inside another device, then the outside of the device into which the module is installed must also display label referring to the enclosed module. This exterior label can use wording such as the following:” Contains Transmitter Module **FCC ID: 2ACHK- V897EA1** Or Contains **FCC ID: 2ACHK- V897EA1** when the module is installed inside another device, the user manual of this device must contain below warning statements;1. This device complies with Part 15 of the FCC Rules. Operation

is subject to the following two conditions : (1) This device may not cause harmful interference. (2) This device must accept any interference received, including interference that may undesired operation. 2. Changes or modifications not expressly approved by the party responsible for compliance could void the user's authority to operate the equipment. The devices must be installed and used in strict accordance with the manufacturer's instructions as described in the user documentation that comes with the product. This device is intended only for OEM integrators under the following conditions: (1) The antenna must be installed such that 20 cm is maintained between the antenna and user. (2) The transmitter module may not be co-located with any other transmitter or antenna. Module

Antenna Type:

For 2.4GHz : Antenna 0: 1.8dBi, Antenna 1: 2.4dBi

For 5GHz: Antenna 0: 6dBi, Antenna 1: 6dBi